



Is Now Part of



ON Semiconductor®

To learn more about ON Semiconductor, please visit our website at
www.onsemi.com

Please note: As part of the Fairchild Semiconductor integration, some of the Fairchild orderable part numbers will need to change in order to meet ON Semiconductor's system requirements. Since the ON Semiconductor product management systems do not have the ability to manage part nomenclature that utilizes an underscore (_), the underscore (_) in the Fairchild part numbers will be changed to a dash (-). This document may contain device numbers with an underscore (_). Please check the ON Semiconductor website to verify the updated device numbers. The most current and up-to-date ordering information can be found at www.onsemi.com. Please email any questions regarding the system integration to Fairchild_questions@onsemi.com.

ON Semiconductor and the ON Semiconductor logo are trademarks of Semiconductor Components Industries, LLC dba ON Semiconductor or its subsidiaries in the United States and/or other countries. ON Semiconductor owns the rights to a number of patents, trademarks, copyrights, trade secrets, and other intellectual property. A listing of ON Semiconductor's product/patent coverage may be accessed at www.onsemi.com/site/pdf/Patent-Marking.pdf. ON Semiconductor reserves the right to make changes without further notice to any products herein. ON Semiconductor makes no warranty, representation or guarantee regarding the suitability of its products for any particular purpose, nor does ON Semiconductor assume any liability arising out of the application or use of any product or circuit, and specifically disclaims any and all liability, including without limitation special, consequential or incidental damages. Buyer is responsible for its products and applications using ON Semiconductor products, including compliance with all laws, regulations and safety requirements or standards, regardless of any support or applications information provided by ON Semiconductor. "Typical" parameters which may be provided in ON Semiconductor data sheets and/or specifications can and do vary in different applications and actual performance may vary over time. All operating parameters, including "Typicals" must be validated for each customer application by customer's technical experts. ON Semiconductor does not convey any license under its patent rights nor the rights of others. ON Semiconductor products are not designed, intended, or authorized for use as a critical component in life support systems or any FDA Class 3 medical devices or medical devices with a same or similar classification in a foreign jurisdiction or any devices intended for implantation in the human body. Should Buyer purchase or use ON Semiconductor products for any such unintended or unauthorized application, Buyer shall indemnify and hold ON Semiconductor and its officers, employees, subsidiaries, affiliates, and distributors harmless against all claims, costs, damages, and expenses, and reasonable attorney fees arising out of, directly or indirectly, any claim of personal injury or death associated with such unintended or unauthorized use, even if such claim alleges that ON Semiconductor was negligent regarding the design or manufacture of the part. ON Semiconductor is an Equal Opportunity/Affirmative Action Employer. This literature is subject to all applicable copyright laws and is not for resale in any manner.

MM74HC86

Quad 2-Input Exclusive OR Gate

Features

- Typical Propagation Delay: 9ns
- Wide Operating Voltage Range: 2–6V
- Low Input Current: 1mA Maximum
- Low Quiescent Current: 20mA Max. (74 Series)
- Output Drive Capability: 10 LS-TTL Loads

Description

The MM74HC86 exclusive OR gate utilizes advanced silicon-gate CMOS technology to achieve operating speeds similar to equivalent LS-TTL gates, while maintaining the low power consumption and high noise immunity characteristic of standard CMOS integrated circuits. These gates are fully buffered and have a fanout of 10 LS-TTL loads. The 74HC logic family is functionally as well as pin-out compatible with the standard 74LS logic family. All inputs are protected from damage due to static discharge by internal diode clamps to V_{CC} and ground.

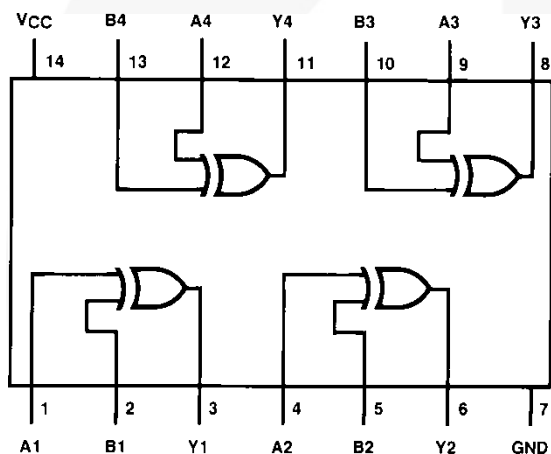

Figure 1. Pin Assignments (Top View)

Table 1. Truth Table

Inputs		Outputs
A	B	$Y^{(1)}$
L	L	L
L	H	H
H	L	H
H	H	L

Note:

1. $Y = A \oplus B = \bar{A}B + A\bar{B}$

Ordering Information

Part Number	Operating Temperature Range	Package	Packing Method
MM74HC86M	-40 to +85°C	14-Lead, Small Outline Integrated Circuit (SOIC), JEDEC MS-012, 0.150" Narrow	Tube
MM74HC86MX			Tape & Reel
MM74HC86MTC		14-Lead, Thin Shrink Small Outline Package (TSSOP), JEDEC MO-153, 4.4mm Wide	Tube
MM74HC86MTCX			Tape & Reel

Note:

2. Pb-Free package per JEDEC J-STD-020B.

Absolute Maximum Ratings

Stresses exceeding the absolute maximum ratings may damage the device. The device may not function or be operable above the recommended operating conditions and stressing the parts to these levels is not recommended. In addition, extended exposure to stresses above the recommended operating conditions may affect device reliability. Absolute maximum ratings are stress ratings only. Unless otherwise specified, all voltages are referenced to ground.

Symbol	Parameter	Min.	Max.	Unit
V_{CC}	Supply Voltage	-0.5	7.0	V
V_{IN}	DC Input Voltage	-1.5	$V_{CC} + 1.5$	V
V_{OUT}	DC Output Voltage	-0.5	$V_{CC} + 0.5$	V
I_{IK}, I_{OK}	Clamp Diode Current	±20		mA
I_{OUT}	DC Output Current, per Pin	±25		mA
I_{CC}	DC VCC or GND Current, per Pin	±50		mA
T_{STG}	Storage Temperature Range	-65	+150	°C
T_L	Lead Temperature (Soldering, 10 Seconds)		260	°C
P_D	Power Dissipation ^(3, 4)		600	mW

Note:

- Power dissipation temperature derating — plastic “N” package: -12 mW/°C from 65°C to 85°C.
- S.O. package only 500mW.

Recommended Operating Conditions

The Recommended Operating Conditions table defines the conditions for actual device operation. Recommended operating conditions are specified to ensure optimal performance to the datasheet specifications. Fairchild does not recommend exceeding them or designing to Absolute Maximum Ratings.

Symbol	Parameter	Conditions	Min.	Max.	Unit
V_{CC}	Supply Voltage		2	6	V
V_{IN}, V_{OUT}	DC Input or Output Voltage		0	V_{CC}	V
T_A	Operating Temperature Range		-40	+85	°C
t_R, t_F	Input Rise or Fall Times	$V_{CC} = 2.0V$		1000	ns
		$V_{CC} = 4.5V$		500	
		$V_{CC} = 6.0V$		400	

DC Electrical Characteristics⁽⁵⁾

Symbol	Parameter	Condition	V _{CC} (V)	T _A =25°C		T _A =-40 to +85°C	T _A =-55 to +125°C	Units
				Typ.	Guaranteed Limit			
V _{IH}	Minimum HIGH Level Input Voltage		2.0		1.5	1.5	1.5	V
			4.5		3.15	3.15	3.15	
			6.0		4.2	4.2	4.2	
V _{IL}	Maximum LOW Level Input Voltage		2.0		0.5	0.5	0.5	V
			4.5		1.35	1.35	1.35	
			6.0		1.8	1.8	1.8	
V _{OH}	Minimum HIGH Level Output Voltage	V _{IN} = V _{IH} or V _{IL} , I _{OUT} ≤ 20μA	2.0	2.0	1.9	1.9	1.9	V
			4.5	4.5	4.4	4.4	4.4	
			6.0	6.0	5.9	5.9	5.9	
		V _{IN} = V _{IH} or V _{IL} , I _{OUT} ≤ 4.0mA	4.5	4.2	3.98	3.84	3.70	
		V _{IN} = V _{IH} or V _{IL} , I _{OUT} ≤ 5.2mA	6.0	5.7	5.48	5.34	5.20	
V _{OL}	Maximum LOW Level Output Voltage	V _{IN} = V _{IH} or V _{IL} , I _{OUT} ≤ 20μA	2.0	0	0.1	0.1	0.1	V
			4.5	0	0.1	0.1	0.1	
			6.0	0	0.1	0.1	0.1	
		V _{IN} = V _{IH} or V _{IL} , I _{OUT} ≤ 4.0mA	4.5	0.2	0.26	0.33	0.40	
		V _{IN} = V _{IH} or V _{IL} , I _{OUT} ≤ 5.2mA	6.0	0.2	0.26	0.33	0.40	
I _{IN}	Maximum Input Current	V _{IN} = V _{CC} or GND	6.0		±0.1	±1.0	±1.0	mA
I _{CC}	Maximum Quiescent Supply Current	V _{IN} = V _{CC} or GND, I _{OUT} = 0mA	6.0		2.0	20	40	mA

Note:

5. For a power supply of 5V ±10%, the worst-case output voltages (V_{OH} and V_{OL}) occur for HC at 4.5V. Thus, the 4.5V values should be used when designing with this supply. Worst-case V_{IH} and V_{IL} occur at V_{CC} = 5.5V and 4.5V, respectively. (The V_{IH} values at 5V and 5.5V are 3.5V and 3.85V, respectively.) The worst-case leakage current (I_{IN}, I_{CC}, and I_{OZ}) occurs for CMOS at the higher voltage, so the 6.0V values should be used.

AC Electrical Characteristics

Symbol	Parameter	Conditions	V _{CC}	T _A =25°C		T _A =-40 to +85°C	T _A =-55 to +125°C	Unit s
				Typ.	Guaranteed Limit			
t _{PHL} , t _{PLH}	Maximum Propagation Delay	C _L = 15pF, t _R = t _F = 6ns	5.0	12		20		ns
t _{PHL} , t _{PLH}	Maximum Propagation Delay		2.0	60	120	151	179	ns
			4.5	12	24	30	36	
			6.0	10	20	26	30	
t _{TLH} , t _{THL}	Maximum Output Rise and Fall Time	C _L = 50pF, t _R = t _F = 6ns	2.0	30	75	95	110	ns
			4.5	8	15	19	22	
			6.0	7	13	16	19	
C _{PD}	Power Dissipation Capacitance (per Gate) ⁽⁶⁾			25				pF
C _{IN}	Maximum Input Capacitance			5	10	10	10	pF

Note:

6. C_{PD} determines the no-load dynamic power consumption, $P_D = C_{PD} V_{CC}^2 f + I_{CC} V_{CC}$, and the no load dynamic current consumption, $I_S = C_{PD} V_{CC} f + I_{CC}$.



NOTES:

- A. CONFORMS TO JEDEC REGISTRATION MO-153, VARIATION AB, REF NOTE 6
- B. DIMENSIONS ARE IN MILLIMETERS.
- C. DIMENSIONS ARE EXCLUSIVE OF BURRS, MOLD FLASH, AND TIE BAR EXTRUSIONS
- D. DIMENSIONING AND TOLERANCES PER ANSI Y14.5M, 2009.
- E. LANDPATTERN STANDARD: SOP65P640X110-14M.
- F. DRAWING FILE NAME: MKT-MTC14rev7.



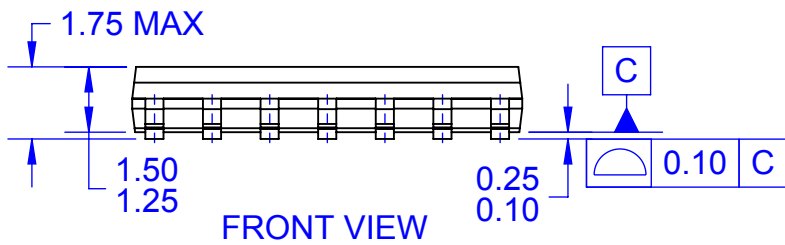

NOTES:

- A. CONFORMS TO JEDEC MS-012, VARIATION AB, ISSUE C
- B. ALL DIMENSIONS ARE IN MILLIMETERS
- C. DIMENSIONS DO NOT INCLUDE MOLD FLASH OR BURRS
- D. LAND PATTERN STANDARD: SOIC127P600X145-14M
- E. CONFORMS TO ASME Y14.5M, 2009
- D. DRAWING FILENAME: MKT-M14Arev14

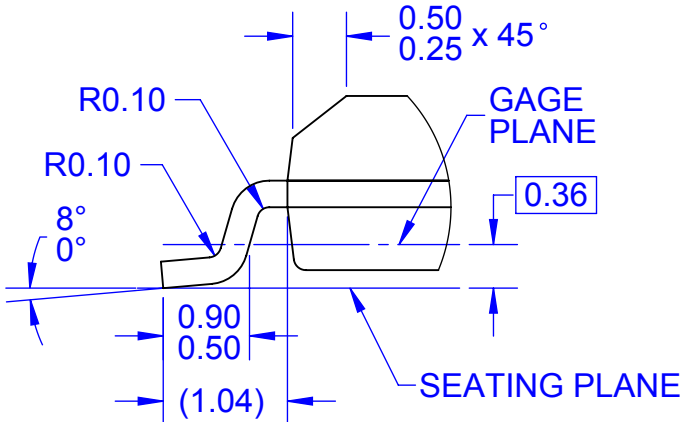

ON Semiconductor and  are trademarks of Semiconductor Components Industries, LLC dba ON Semiconductor or its subsidiaries in the United States and/or other countries. ON Semiconductor owns the rights to a number of patents, trademarks, copyrights, trade secrets, and other intellectual property. A listing of ON Semiconductor's product/patent coverage may be accessed at www.onsemi.com/site/pdf/Patent-Marking.pdf. ON Semiconductor reserves the right to make changes without further notice to any products herein. ON Semiconductor makes no warranty, representation or guarantee regarding the suitability of its products for any particular purpose, nor does ON Semiconductor assume any liability arising out of the application or use of any product or circuit, and specifically disclaims any and all liability, including without limitation special, consequential or incidental damages. Buyer is responsible for its products and applications using ON Semiconductor products, including compliance with all laws, regulations and safety requirements or standards, regardless of any support or applications information provided by ON Semiconductor. "Typical" parameters which may be provided in ON Semiconductor data sheets and/or specifications can and do vary in different applications and actual performance may vary over time. All operating parameters, including "Typicals" must be validated for each customer application by customer's technical experts. ON Semiconductor does not convey any license under its patent rights nor the rights of others. ON Semiconductor products are not designed, intended, or authorized for use as a critical component in life support systems or any FDA Class 3 medical devices or medical devices with a same or similar classification in a foreign jurisdiction or any devices intended for implantation in the human body. Should Buyer purchase or use ON Semiconductor products for any such unintended or unauthorized application, Buyer shall indemnify and hold ON Semiconductor and its officers, employees, subsidiaries, affiliates, and distributors harmless against all claims, costs, damages, and expenses, and reasonable attorney fees arising out of, directly or indirectly, any claim of personal injury or death associated with such unintended or unauthorized use, even if such claim alleges that ON Semiconductor was negligent regarding the design or manufacture of the part. ON Semiconductor is an Equal Opportunity/Affirmative Action Employer. This literature is subject to all applicable copyright laws and is not for resale in any manner.

PUBLICATION ORDERING INFORMATION

LITERATURE FULFILLMENT:

Literature Distribution Center for ON Semiconductor
19521 E. 32nd Pkwy, Aurora, Colorado 80011 USA
Phone: 303-675-2175 or 800-344-3860 Toll Free USA/Canada
Fax: 303-675-2176 or 800-344-3867 Toll Free USA/Canada
Email: orderlit@onsemi.com

N. American Technical Support: 800-282-9855 Toll Free
USA/Canada
Europe, Middle East and Africa Technical Support:
Phone: 421 33 790 2910
Japan Customer Focus Center
Phone: 81-3-5817-1050

ON Semiconductor Website: www.onsemi.com
Order Literature: <http://www.onsemi.com/orderlit>
For additional information, please contact your local
Sales Representative

Looking for pricing, stock, or lifecycle information?

Click below to explore more details on WIN SOURCE:

- ⊖ [View MM74HC86MTCX on WIN SOURCE](#)
- ⊖ [Fairchild/ON Semiconductor Information](#)

Optimize Your Supply Chain with WIN SOURCE Solutions

- ✓ Global Sourcing Solution
- ✓ Obsolete Management
- ✓ Cost Control Management
- ✓ Shortage Management
- ✓ Alternative Solution
- ✓ Excess Inventory Management