



THE DATASHEET OF MOCD207M



8-pin SOIC Dual-Channel Phototransistor Output Optocoupler

MOCD207M, MOCD208M, MOCD211M, MOCD213M, MOCD217M

These devices consist of two gallium arsenide infrared emitting diodes optically coupled to two monolithic silicon phototransistor detectors, in a surface mountable, small outline, plastic package. They are ideally suited for high-density applications, and eliminate the need for through-the-board mounting.

Features

- Closely Matched Current Transfer Ratios
- Minimum BV_{CEO} of 70 V Guaranteed
 - MOCD207M, MOCD208M, MOCD213M
- Minimum BV_{CEO} of 30 V Guaranteed
 - MOCD211M, MOCD217M
- Low LED Input Current Required for Easier Logic Interfacing
 - MOCD217M
- Convenient Plastic SOIC-8 Surface Mountable Package Style, with 0.050" Lead Spacing
- Safety and Regulatory Approvals:
 - UL1577, 2,500 VAC_{RMS} for 1 Minute
 - DIN-EN/IEC60747-5-5, 565 V Peak Working Insulation Voltage
- These are Pb-Free Devices

Applications

- Feedback Control Circuits
- Interfacing and Coupling Systems of Different Potentials and Impedances
- General Purpose Switching Circuits
- Monitor and Detection Circuits

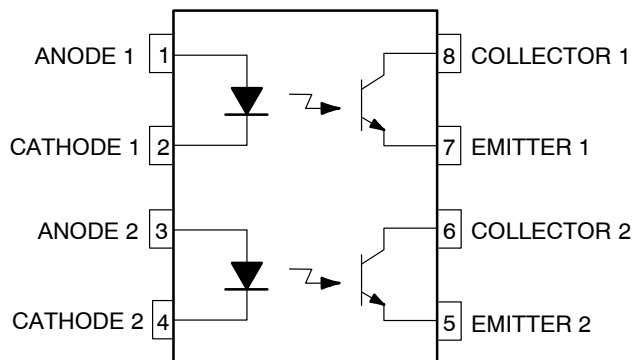
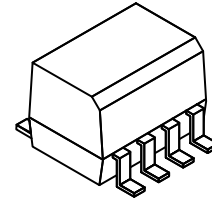
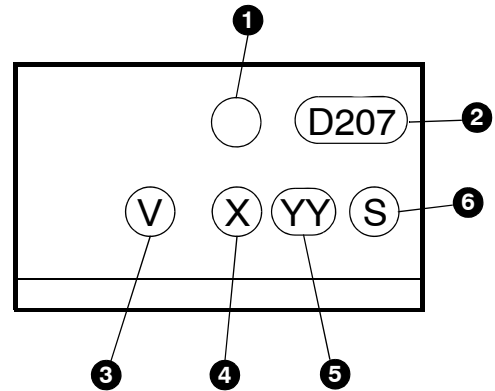

Figure 1. Schematic



SOIC8
M SUFFIX
CASE 751DZ

MARKING DIAGRAM



- 1 – Logo
- 2 – Device Number
- 3 – DIN EN/IEC60747-5-5 Option (only appears on component ordered with this option)
- 4 – One-Digit Year Code, e.g., “4”
- 5 – Digit Work Week, Ranging from “01” to “53”
- 6 – Assembly Package Code

ORDERING INFORMATION

See detailed ordering and shipping information in the package dimensions section on page 7 of this data sheet.

MOCD207M, MOCD208M, MOCD211M, MOCD213M, MOCD217M

Safety and Insulation Ratings

As per DIN EN/IEC 60747-5-5, this optocoupler is suitable for “safe electrical insulation” only within the safety limit data. Compliance with the safety ratings shall be ensured by means of protective circuits.

Parameter		Characteristics
Installation Classifications per DIN VDE 0110/1.89 Table 1, For Rated Mains Voltage	< 150 V _{RMS}	I-IV
	< 300 V _{RMS}	I-III
Climatic Classification		55/100/21
Pollution Degree (DIN VDE 0110/1.89)		2
Comparative Tracking Index		175

Symbol	Parameter	Value	Unit
V _{PR}	Input-to-Output Test Voltage, Method A, V _{IO_{RM}} × 1.6 = V _{PR} , Type and Sample Test with t _m = 10 s, Partial Discharge < 5 pC	904	V _{peak}
	Input-to-Output Test Voltage, Method B, V _{IO_{RM}} × 1.875 = V _{PR} , 100% Production Test with t _m = 1 s, Partial Discharge < 5 pC	1060	V _{peak}
V _{IO_{RM}}	Maximum Working Insulation Voltage	565	V _{peak}
V _{IO_{TM}}	Highest Allowable Over-Voltage	4000	V _{peak}
	External Creepage	≥4	mm
	External Clearance	≥4	mm
DTI	Distance Through Insulation (Insulation Thickness)	≥0.4	mm
T _S	Case Temperature (Note 1)	150	°C
I _{S,INPUT}	Input Current (Note 1)	200	mA
P _{S,OUTPUT}	Output Current (Note 1)	300	mW
R _{IO}	Insulation Resistance at T _S , V _{IO} = 500 V (Note 1)	>10 ⁹	Ω

1. Safety limit values – maximum values allowed in the event of a failure.

MOCD207M, MOCD208M, MOCD211M, MOCD213M, MOCD217M

ABSOLUTE MAXIMUM RATINGS ($T_A = 25^\circ\text{C}$ unless otherwise noted)

Symbol	Rating	Value	Unit
TOTAL DEVICE			
T_{STG}	Storage Temperature	-40 to +125	$^\circ\text{C}$
T_A	Ambient Operating Temperature	-40 to +100	$^\circ\text{C}$
T_J	Junction Temperature	-40 to +125	$^\circ\text{C}$
T_{SOL}	Lead Solder Temperature	260 for 10 seconds	$^\circ\text{C}$
P_D	Total Device Power Dissipation @ $T_A = 25^\circ\text{C}$	240	mW
	Derate Above 25°C	2.94	$\text{mW}/^\circ\text{C}$
EMITTER			
I_F	Continuous Forward Current	60	mA
I_F (pk)	Forward Current – Peak ($PW = 100 \mu\text{s}$, 120 pps)	1.0	A
V_R	Reverse Voltage	6.0	V
P_D	LED Power Dissipation @ $T_A = 25^\circ\text{C}$	90	mW
	Derate Above 25°C	0.8	$\text{mW}/^\circ\text{C}$
DETECTOR			
I_C	Continuous Collector Current	150	mA
V_{CEO}	Collector–Emitter Voltage – MOCD207M, MOCD208M, MOCD213M	70	V
	– MOCD211M, MOCD217M	30	V
V_{ECO}	Emitter–Collector Voltage	7	V
P_D	Detector Power Dissipation @ $T_A = 25^\circ\text{C}$	150	mW
	Derate Above 25°C	1.76	$\text{mW}/^\circ\text{C}$

Stresses exceeding those listed in the Maximum Ratings table may damage the device. If any of these limits are exceeded, device functionality should not be assumed, damage may occur and reliability may be affected.

MOCD207M, MOCD208M, MOCD211M, MOCD213M, MOCD217M

ELECTRICAL CHARACTERISTICS ($T_A = 25^\circ\text{C}$ unless otherwise noted)

Symbol	Parameter	Device	Test Conditions	Min	Typ	Max	Unit
EMITTER							
V_F	Input Forward Voltage	MOCD217M	$I_F = 1 \text{ mA}$	–	1.05	1.3	V
		MOCD213M	$I_F = 10 \text{ mA}$	–	1.15	1.5	V
		MOCD207M, MOCD208M, MOCD211M	$I_F = 30 \text{ mA}$	–	1.25	1.5	V
I_R	Reverse Leakage Current	All	$V_R = 6 \text{ V}$	–	0.001	100	μA
C_{IN}	Input Capacitance	All		–	18	–	pF

DETECTOR

I_{CEO}	Collector–Emitter Dark Current	All	$V_{CE} = 10 \text{ V}, T_A = 25^\circ\text{C}$	–	1.0	50	nA
			$V_{CE} = 10 \text{ V}, T_A = 100^\circ\text{C}$	–	1.0	–	μA
BV_{CEO}	Collector–Emitter Breakdown Voltage	MOCD211M, MOCD217M	$I_C = 100 \mu\text{A}$	30	100	–	V
		MOCD207M, MOCD208M, MOCD213M	$I_C = 100 \mu\text{A}$	70	100	–	V
BV_{ECO}	Emitter–Collector Breakdown Voltage	All	$I_E = 100 \mu\text{A}$	7	10	–	V
C_{CE}	Collector–Emitter Capacitance	All	$f = 1.0 \text{ MHz}, V_{CE} = 0$	–	7	–	pF

COUPLED

CTR	Collector–Output Current	MOCD207M	$I_F = 10 \text{ mA}, V_{CE} = 5 \text{ V}$	100	–	200	%
		MOCD208M	$I_F = 10 \text{ mA}, V_{CE} = 5 \text{ V}$	40	–	125	%
		MOCD211M	$I_F = 10 \text{ mA}, V_{CE} = 5 \text{ V}$	20	–	–	%
		MOCD213M	$I_F = 10 \text{ mA}, V_{CE} = 5 \text{ V}$	100	–	–	%
		MOCD217M	$I_F = 1 \text{ mA}, V_{CE} = 5 \text{ V}$	100	–	–	%
$V_{CE(SAT)}$	Collector–Emitter Saturation Voltage	MOCD207M, MOCD208M, MOCD211M, MOCD213M	$I_C = 2 \text{ mA}, I_F = 10 \text{ mA}$	–	–	0.4	V
		MOCD217M	$I_C = 100 \mu\text{A}, I_F = 1 \text{ mA}$	–	–	0.4	V
t_{on}	Turn–On Time	All	$I_C = 2 \text{ mA}, V_{CC} = 10 \text{ V}, R_L = 100 \Omega$ (Figure 7)	–	7.5	–	μs
t_{off}	Turn–Off Time	All	$I_C = 2 \text{ mA}, V_{CC} = 10 \text{ V}, R_L = 100 \Omega$ (Figure 7)	–	5.7	–	μs
t_r	Rise Time	All	$I_C = 2 \text{ mA}, V_{CC} = 10 \text{ V}, R_L = 100 \Omega$ (Figure 7)	–	3.2	–	μs
t_f	Fall Time	All	$I_C = 2 \text{ mA}, V_{CC} = 10 \text{ V}, R_L = 100 \Omega$ (Figure 7)	–	4.7	–	μs

ISOLATION

V_{ISO}	Input–Output Isolation Voltage	All	$t = 1 \text{ Minute}$	2500	–	–	$V_{AC_{RMS}}$
C_{ISO}	Isolation Capacitance	All	$V_{I-O} = 0 \text{ V}, f = 1 \text{ MHz}$	–	0.2	–	pF
R_{ISO}	Isolation Resistance	All	$V_{I-O} = \pm 500 \text{ VDC}, T_A = 25^\circ\text{C}$	10^{11}	–	–	Ω

Product parametric performance is indicated in the Electrical Characteristics for the listed test conditions, unless otherwise noted. Product performance may not be indicated by the Electrical Characteristics if operated under different conditions.

TYPICAL CHARACTERISTICS

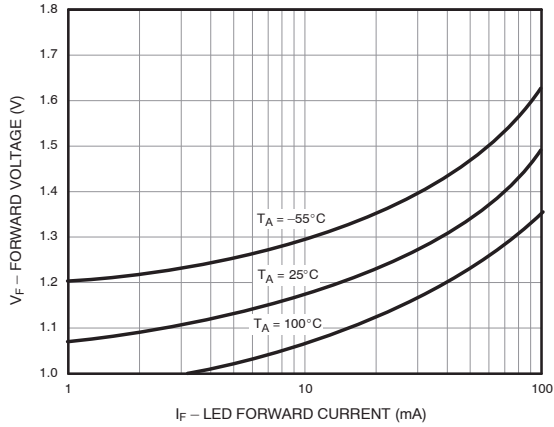

Figure 2. LED Forward Voltage vs. Forward Current

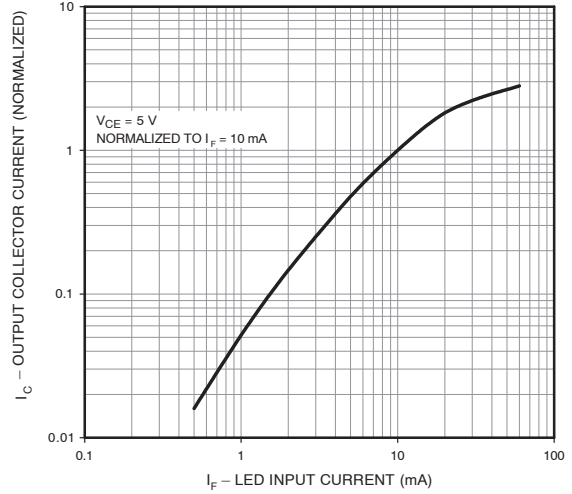

Figure 3. Output Current vs. Input Current

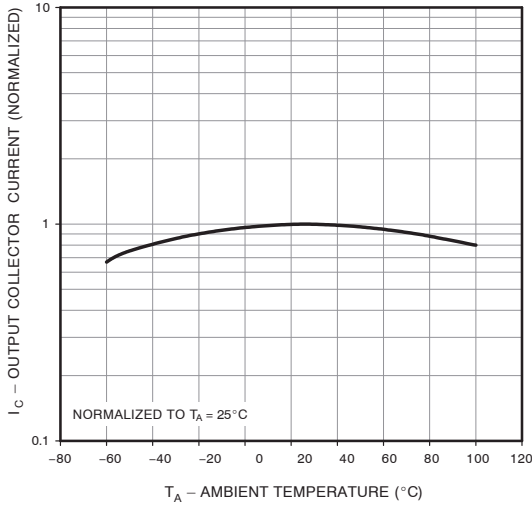

Figure 4. Output Current vs. Ambient Temperature

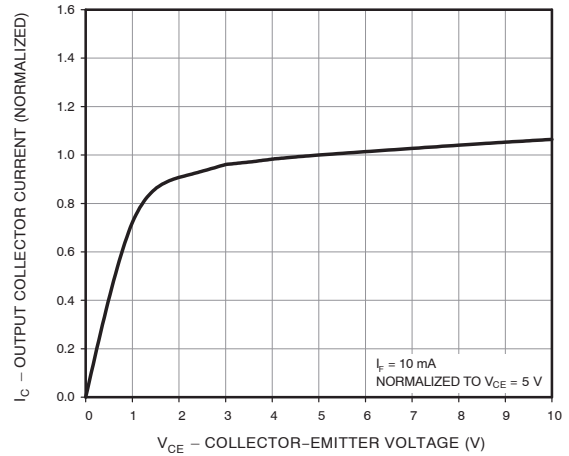

Figure 5. Output Current vs. Collector-Emitter Voltage

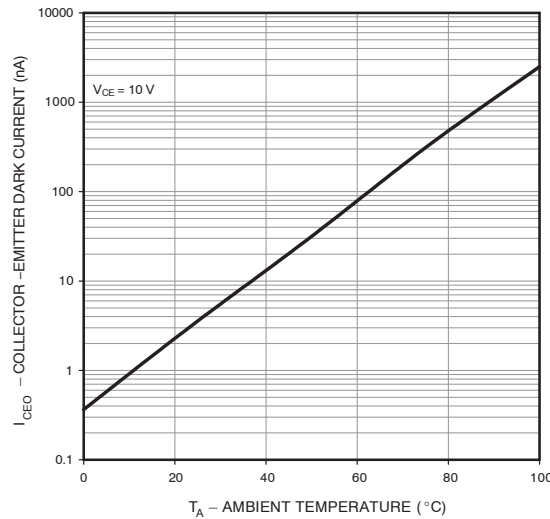

Figure 6. Dark Current vs. Ambient Temperature

SWITCHING TIME TEST CIRCUIT AND WAVEFORMS

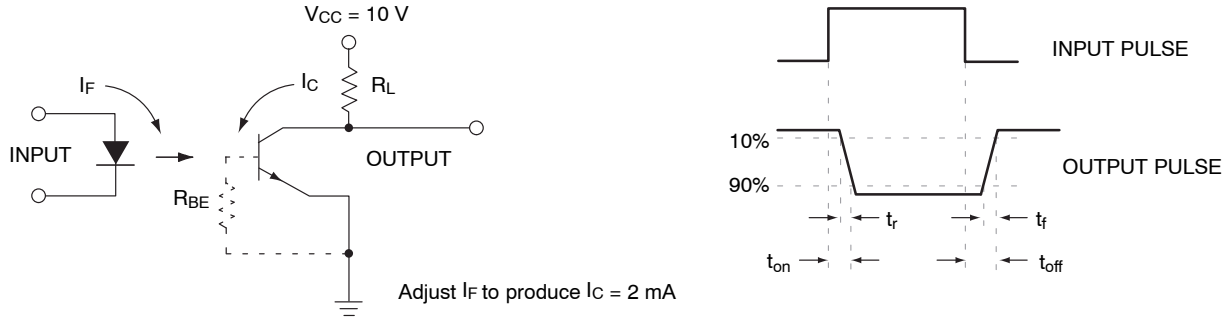

Figure 7. Switching Time Test Circuit and Waveforms

REFLOW PROFILE

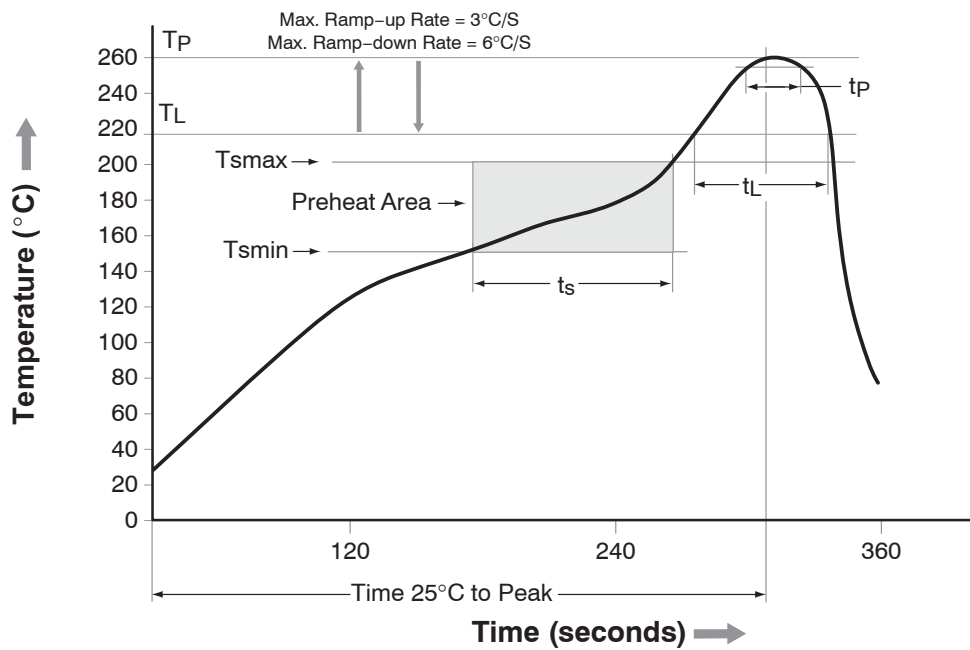

Figure 8. Reflow Profile

Profile Feature	Pb-Free Assembly Profile
Temperature Minimum (T_{smin})	150°C
Temperature Maximum (T_{smax})	200°C
Time (t_s) from (T_{smin} to T_{smax})	60 – 120 seconds
Ramp-up Rate (t_L to t_p)	3°C/second maximum
Liquidous Temperature (T_L)	217°C
Time (t_L) Maintained Above (T_L)	60 – 150 seconds
Peak Body Package Temperature	260°C +0°C / -5°C
Time (t_p) within 5°C of 260°C	30 seconds
Ramp-down Rate (T_P to T_L)	6°C/second maximum
Time 25°C to Peak Temperature	8 minutes maximum

MOCD207M, MOCD208M, MOCD211M, MOCD213M, MOCD217M

ORDERING INFORMATION

Part Number	Package	Shipping
MOCD207M	Small Outline 8-Pin	50 Units / Tube
MOCD207R2M	Small Outline 8-Pin	2500 Units / Tape & Reel
MOCD207VM	Small Outline 8-Pin, DIN EN/IEC60747-5-5 Option	50 Units / Tube
MOCD207R2VM	Small Outline 8-Pin, DIN EN/IEC60747-5-5 Option	2500 Units / Tape & Reel
MOCD208M	Small Outline 8-Pin	50 Units / Tube
MOCD208R2M	Small Outline 8-Pin	2500 Units / Tape & Reel
MOCD208VM	Small Outline 8-Pin, DIN EN/IEC60747-5-5 Option	50 Units / Tube
MOCD208R2VM	Small Outline 8-Pin, DIN EN/IEC60747-5-5 Option	2500 Units / Tape & Reel
MOCD211M	Small Outline 8-Pin	50 Units / Tube
MOCD211R2M	Small Outline 8-Pin	2500 Units / Tape & Reel
MOCD211VM	Small Outline 8-Pin, DIN EN/IEC60747-5-5 Option	50 Units / Tube
MOCD211R2VM	Small Outline 8-Pin, DIN EN/IEC60747-5-5 Option	2500 Units / Tape & Reel
MOCD213M	Small Outline 8-Pin	50 Units / Tube
MOCD213R2M	Small Outline 8-Pin	2500 Units / Tape & Reel
MOCD213VM	Small Outline 8-Pin, DIN EN/IEC60747-5-5 Option	50 Units / Tube
MOCD213R2VM	Small Outline 8-Pin, DIN EN/IEC60747-5-5 Option	2500 Units / Tape & Reel
MOCD217M	Small Outline 8-Pin	50 Units / Tube
MOCD217R2M	Small Outline 8-Pin	2500 Units / Tape & Reel
MOCD217VM	Small Outline 8-Pin, DIN EN/IEC60747-5-5 Option	50 Units / Tube
MOCD217R2VM	Small Outline 8-Pin, DIN EN/IEC60747-5-5 Option	2500 Units / Tape & Reel

MECHANICAL CASE OUTLINE

PACKAGE DIMENSIONS

ON Semiconductor®



SOIC8
CASE 751DZ
ISSUE O

DATE 30 SEP 2016

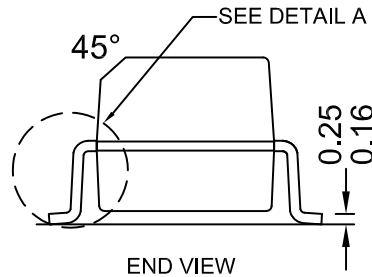
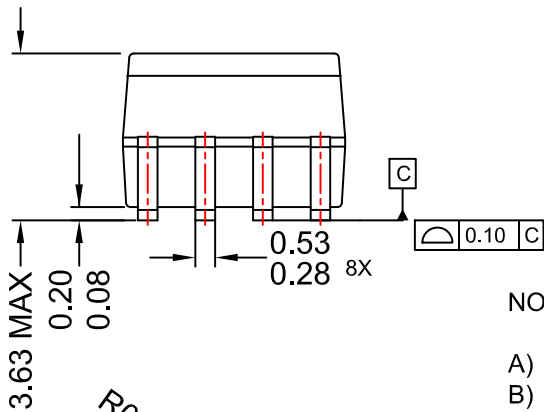
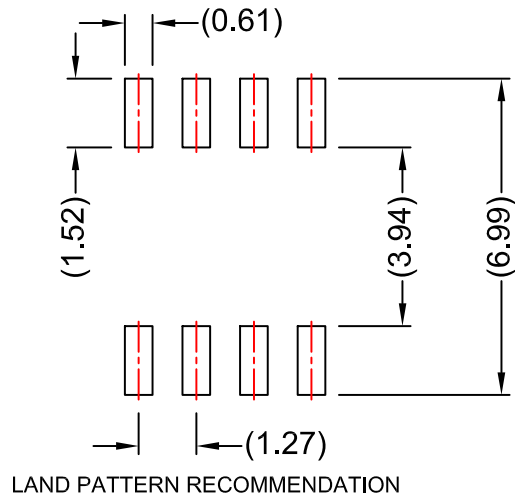
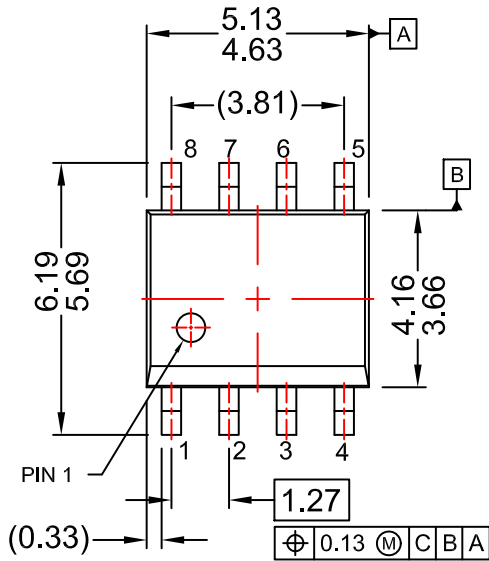

NOTES:

- A) NO STANDARD APPLIES TO THIS PACKAGE
- B) ALL DIMENSIONS ARE IN MILLIMETERS.
- C) DIMENSIONS DO NOT INCLUDE MOLD FLASH OR BURRS.
- D) LANDPATTERN STANDARD: SOIC127P600X175-8M.

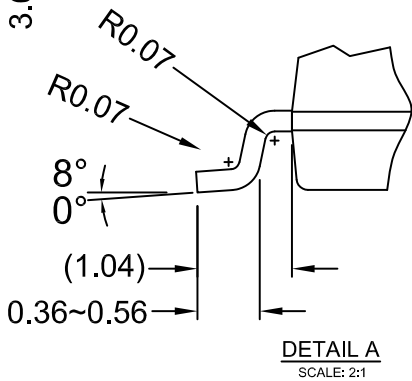

DOCUMENT NUMBER:	98AON13733G	Electronic versions are uncontrolled except when accessed directly from the Document Repository. Printed versions are uncontrolled except when stamped "CONTROLLED COPY" in red.
DESCRIPTION:	SOIC8	PAGE 1 OF 1

ON Semiconductor and are trademarks of Semiconductor Components Industries, LLC dba ON Semiconductor or its subsidiaries in the United States and/or other countries. ON Semiconductor reserves the right to make changes without further notice to any products herein. ON Semiconductor makes no warranty, representation or guarantee regarding the suitability of its products for any particular purpose, nor does ON Semiconductor assume any liability arising out of the application or use of any product or circuit, and specifically disclaims any and all liability, including without limitation special, consequential or incidental damages. ON Semiconductor does not convey any license under its patent rights nor the rights of others.

onsemi, **Onsemi**, and other names, marks, and brands are registered and/or common law trademarks of Semiconductor Components Industries, LLC dba "**onsemi**" or its affiliates and/or subsidiaries in the United States and/or other countries. **onsemi** owns the rights to a number of patents, trademarks, copyrights, trade secrets, and other intellectual property. A listing of **onsemi**'s product/patent coverage may be accessed at www.onsemi.com/site/pdf/Patent-Marking.pdf. **onsemi** reserves the right to make changes at any time to any products or information herein, without notice. The information herein is provided "as-is" and **onsemi** makes no warranty, representation or guarantee regarding the accuracy of the information, product features, availability, functionality, or suitability of its products for any particular purpose, nor does **onsemi** assume any liability arising out of the application or use of any product or circuit, and specifically disclaims any and all liability, including without limitation special, consequential or incidental damages. Buyer is responsible for its products and applications using **onsemi** products, including compliance with all laws, regulations and safety requirements or standards, regardless of any support or applications information provided by **onsemi**. "Typical" parameters which may be provided in **onsemi** data sheets and/or specifications can and do vary in different applications and actual performance may vary over time. All operating parameters, including "Typicals" must be validated for each customer application by customer's technical experts. **onsemi** does not convey any license under any of its intellectual property rights nor the rights of others. **onsemi** products are not designed, intended, or authorized for use as a critical component in life support systems or any FDA Class 3 medical devices or medical devices with a same or similar classification in a foreign jurisdiction or any devices intended for implantation in the human body. Should Buyer purchase or use **onsemi** products for any such unintended or unauthorized application, Buyer shall indemnify and hold **onsemi** and its officers, employees, subsidiaries, affiliates, and distributors harmless against all claims, costs, damages, and expenses, and reasonable attorney fees arising out of, directly or indirectly, any claim of personal injury or death associated with such unintended or unauthorized use, even if such claim alleges that **onsemi** was negligent regarding the design or manufacture of the part. **onsemi** is an Equal Opportunity/Affirmative Action Employer. This literature is subject to all applicable copyright laws and is not for resale in any manner.

ADDITIONAL INFORMATION

TECHNICAL PUBLICATIONS:

Technical Library: www.onsemi.com/design/resources/technical-documentation
onsemi Website: www.onsemi.com

ONLINE SUPPORT: www.onsemi.com/support

For additional information, please contact your local Sales Representative at www.onsemi.com/support/sales

Looking for pricing, stock, or lifecycle information?

Click below to explore more details on WIN SOURCE:

- ⊖ [View MOCD207M on WIN SOURCE](#)
- ⊖ [Fairchild/ON Semiconductor Information](#)

Optimize Your Supply Chain with WIN SOURCE Solutions

- ✓ Global Sourcing Solution
- ✓ Obsolete Management
- ✓ Cost Control Management
- ✓ Shortage Management
- ✓ Alternative Solution
- ✓ Excess Inventory Management