



**THE DATASHEET OF
MP2102DK-LF-Z**





The Future of Analog IC Technology®

MP2102

1.5MHz, 800mA Dual-Output Synchronous Step-Down Converter

DESCRIPTION

The MP2102 is a dual-output, internally compensated, 1.5MHz fixed frequency PWM step-down converter. It is ideal for powering portable equipment from a single cell Lithium-Ion (Li+) Battery. Each channel of the MP2102 can supply 800mA of load current from a 2.5V to 6V input voltage. Both output voltages can be regulated as low as 0.6V.

The device features integrated high-side switches and synchronous rectifiers for high efficiency step-down conversion without the need for external Schottky diodes. With peak current mode control and internal compensation, the MP2102 can be stabilized with ceramic capacitors and small inductors. Fault condition protection includes cycle-by-cycle current limiting and thermal shutdown.

The MP2102 is available in small 10-pin QFN with exposed pad and 10-pin MSOP packages.

EVALUATION BOARD REFERENCE

Board Number	Dimensions
EV2102DQ-00B	2.2"X x 2.2"Y x 0.4"Z

FEATURES

- Dual 800mA Outputs
- Internal Power MOSFET Switches
- Up to 95% Efficiency
- 1.5MHz Switching Frequency
- 1µA Shutdown Current
- Stable with Low ESR Output Ceramic Capacitors
- Thermal Shutdown
- Cycle-by-Cycle Over Current Protection
- Short Circuit Protection
- Power-On Reset with Programmable Delay
- 2.5V to 6V Operating Input Range
- Output Adjustable from 0.6V to 5.4V
- Input Undervoltage Lockout
- Available in 10-Pin QFN with Exposed Pad and 10-Pin MSOP Packages.

APPLICATIONS

- DVD+/-RW Drive
- Smart Phones
- PDAs
- Digital Cameras
- Portable Instruments

"MPS" and "The Future of Analog IC Technology" are Registered Trademarks of Monolithic Power Systems, Inc.

TYPICAL APPLICATION

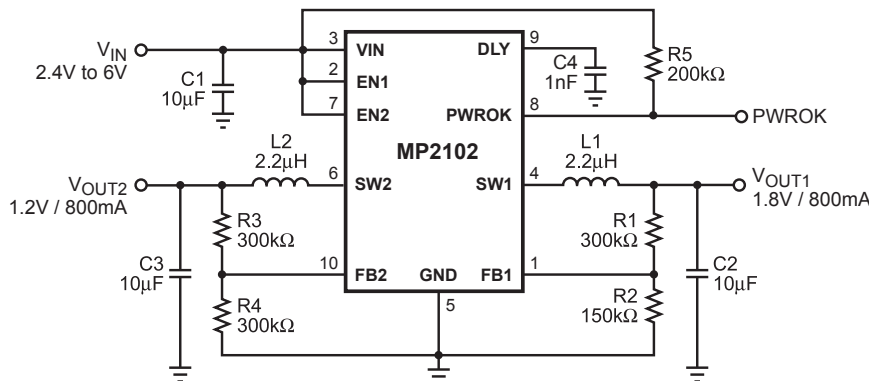

Efficiency vs Load Current

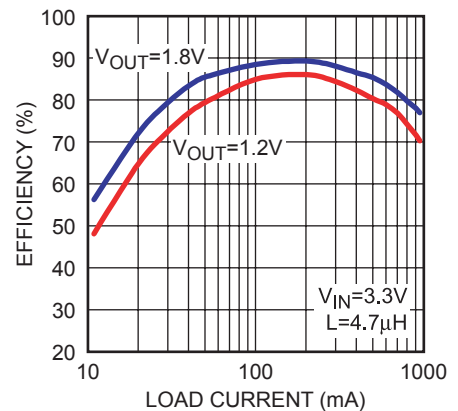

PACKAGE REFERENCE

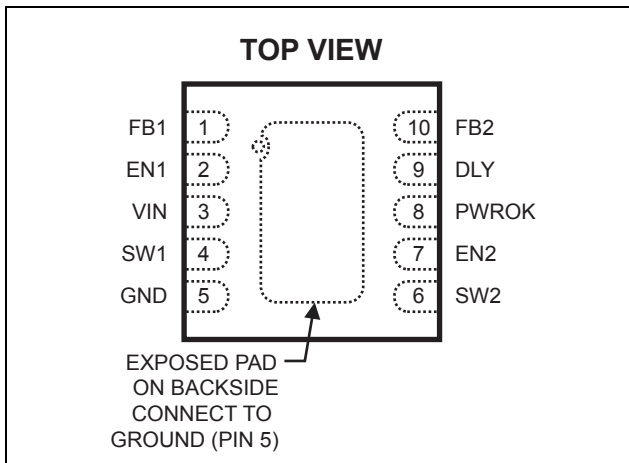

Part Number*	Package	Temperature
MP2102DQ	QFN10 (3mm x 3mm)	-40°C to +85°C

* For Tape & Reel, add suffix -Z (eg. MP2102DQ-Z)
For RoHS Compliant Packaging, add suffix -LF
(eg. MP2102DQ-LF-Z)

ABSOLUTE MAXIMUM RATINGS ⁽¹⁾

V _{IN} to GND	-0.3V to +6.5V
SW1/2 to GND	-0.3V to V _{IN} + 0.3V
FB1/2, OUT1/2, EN1/2 to GND	-0.3V to +6.5V
Operating Temperature	-40°C to +85°C
Junction Temperature	150°C
Lead Temperature	260°C
Storage Temperature	-65°C to +150°C

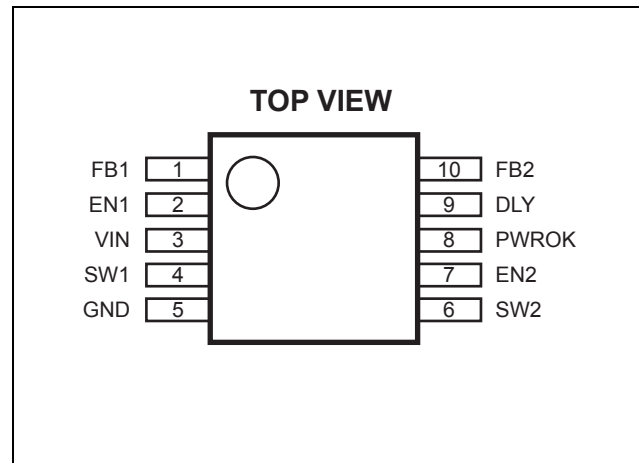

Part Number*	Package	Temperature
MP2102DK	MSOP10	-40°C to +85°C

* For Tape & Reel, add suffix -Z (eg. MP2102DK-Z)
For RoHS Compliant Packaging, add suffix -LF
(eg. MP2102DK-LF-Z)

Recommended Operating Conditions ⁽²⁾

Supply Voltage V _{IN}	2.5V to 6V
Output Voltage V _{OUT}	0.6V to 5.4V
Operating Temperature	-40°C to +85°C

Thermal Resistance ⁽³⁾	θ_{JA}	θ_{JC}
QFN10	50	12
MSOP10	150	65

Notes:

- Exceeding these ratings may damage the device.
- The device is not guaranteed to function outside of its operating conditions.
- Measured on approximately 1" square of 1 oz copper.

ELECTRICAL CHARACTERISTICS ⁽⁴⁾

V_{IN} = V_{EN} = 3.6V, T_A = +25°C, unless otherwise noted.

Parameter	Symbol	Condition	Min	Typ	Max	Units
Supply Current		V _{EN} = V _{IN} , V _{FB} = 0.62V		750		μA
Shutdown Current		V _{EN} = 0V, V _{IN} = 6V		0.01	1	μA
IN Under Voltage Lockout Threshold		Rising Edge	1.7	2.0	2.3	V
IN Under Voltage Lockout Hysteresis				100		mV
Output Line Regulation		V _{IN} = 2.5V to 6V		0.03		%/V
Output Load Regulation		I _{LOAD} = 50mA to 500mA		0.05		%/mA

ELECTRICAL CHARACTERISTICS ⁽⁴⁾ (continued)
 $V_{IN} = V_{EN} = 3.6V$, $T_A = +25^{\circ}C$, unless otherwise noted.

Parameter	Symbol	Condition	Min	Typ	Max	Units
Regulated FB Voltage		$T_A = +25^{\circ}C$	0.588	0.600	0.612	V
		$-40^{\circ}C \leq T_A \leq +85^{\circ}C$	0.582	0.600	0.618	
FB Input Bias Current		$V_{FB} = 0.62V$	-50	-2	+50	nA
SW PFET On Resistance		$I_{SW} = 100mA$		0.4		Ω
SW NFET On Resistance		$I_{SW} = -100mA$		0.3		Ω
SW Leakage Current		$V_{EN} = 0V$, $V_{IN} = 6V$ $V_{SW} = 0V$ or $6V$	-2		+2	μA
SW PFET Peak Current Limit		Duty Cycle = 100%, Current Pulse Width < 1ms	0.9	1.5	2.1	A
Oscillator Frequency			1.2	1.5	1.7	MHz
Thermal Shutdown Trip Threshold				150		$^{\circ}C$
PWROK Upper Trip Threshold		FB1/2/OUT1/2 with respect to the nominal value		10		%
PWROK Lower Trip Threshold		FB1/2/OUT1/2 with respect to the nominal value		-10		%
PWROK Output Lower Voltage		$I_{SINK} = 5mA$			0.3	V
PWROK Deglitch Timer		C4 open	10	45		μs
PWROK Startup Delay		C4 = 1nF		0.5		ms
DLY Pull-Down Resistor				0.8		M Ω
EN1/2 Trip Threshold			0.40	0.98	1.40	V
EN1/2 Trip Threshold		$-40^{\circ}C \leq T_A \leq +85^{\circ}C$	0.30	0.96	1.50	V
EN Pull-Down Resistor				0.8		M Ω

Note:

 4) Production test at +25 $^{\circ}C$. Specifications over the temperature range are guaranteed by design and characterization.

PIN FUNCTIONS

Pin #	Name	Description
1	FB1	Feedback Input 1. Feedback input for output 1.
2	EN1	Enable Input 1. "High" input enables the switcher. It has an internal 800k Ω pull-down resistor.
3	VIN	Input Supply Pin.
4	SW1	Switch Node 1. Switch node to the inductors.
5	GND	Ground Pin.
6	SW2	Switch Node 2. Switch node to the inductors.
7	EN2	Enable Input 2. "High" input enables the switcher. It has an internal 800k Ω pull-down resistor.
8	PWROK	Power-On Reset Open Drain Output. Open drain output indicating that both outputs are within 10% of the final regulation value. "Low" output indicates output is out of $\pm 10\%$ window. PWROK is pulled down in shutdown.
9	DLY	Delay Set. The startup power on reset delay is proportional to the value of C4 connected to this pin. It has an internal 800k Ω pull-down resistor.
10	FB2	Feedback Input 2. Feedback input for output 2.

TYPICAL PERFORMANCE CHARACTERISTICS

$V_{OUT1} = 1.8V$, $V_{OUT2} = 1.2V$, $C1 = C2 = C3 = 10\mu F$, $C4 = 1nF$, $L1 = L2 = 2.2\mu H$, $T_A = +25^\circ C$, unless otherwise noted.

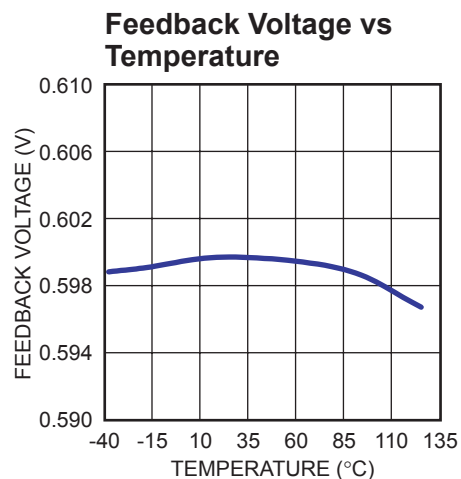
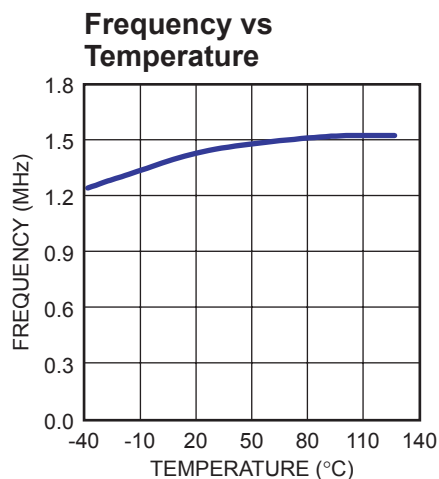
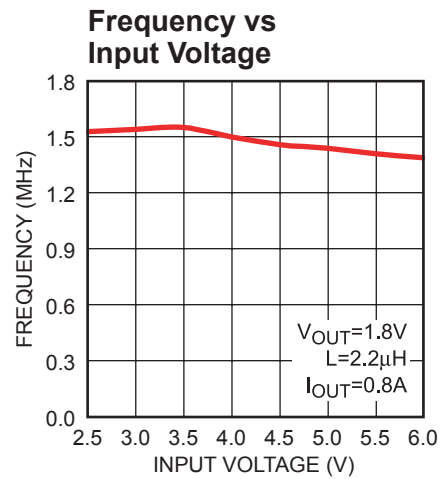
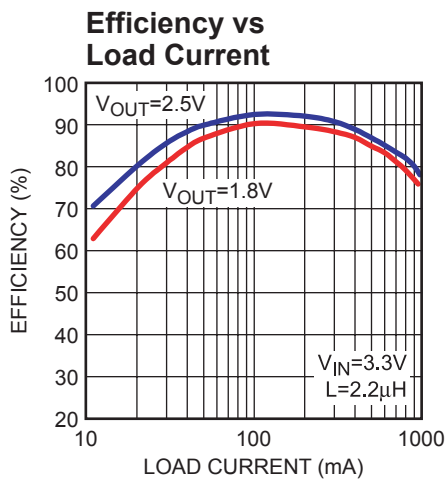
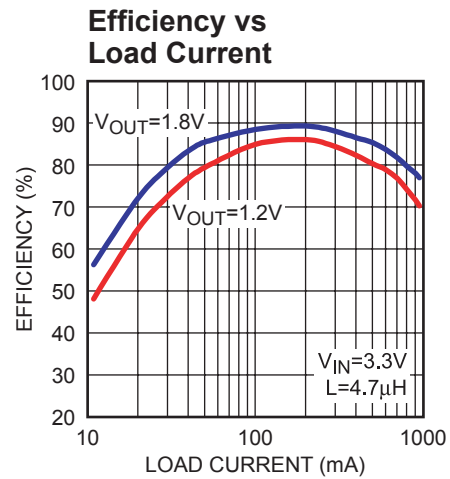
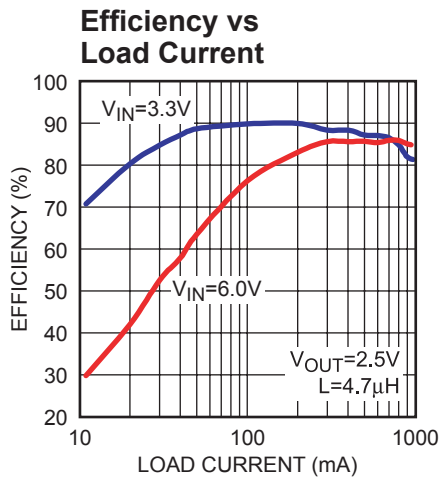

TYPICAL PERFORMANCE CHARACTERISTICS (continued)

$V_{OUT1} = 1.8V$, $V_{OUT2} = 1.2V$, $C1 = C2 = C3 = 10\mu F$, $C4 = 1nF$, $L1 = L2 = 2.2\mu H$, $T_A = +25^\circ C$, unless otherwise noted.

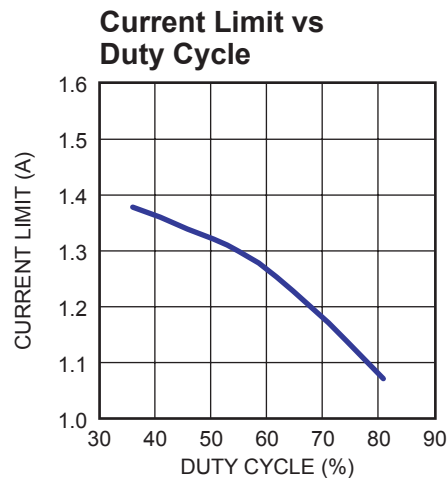
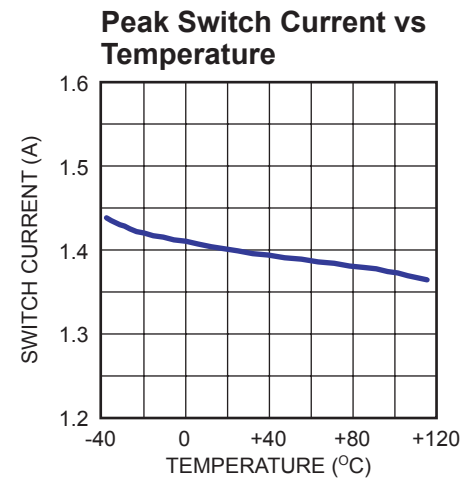
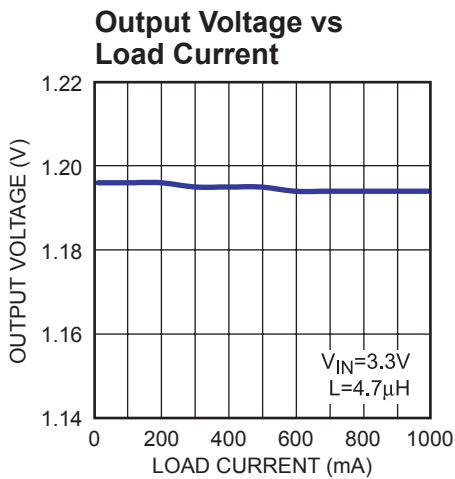
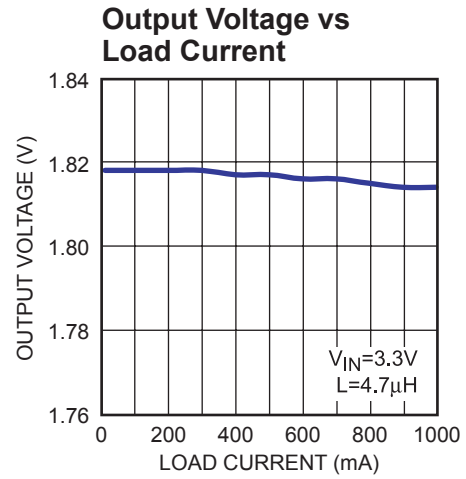
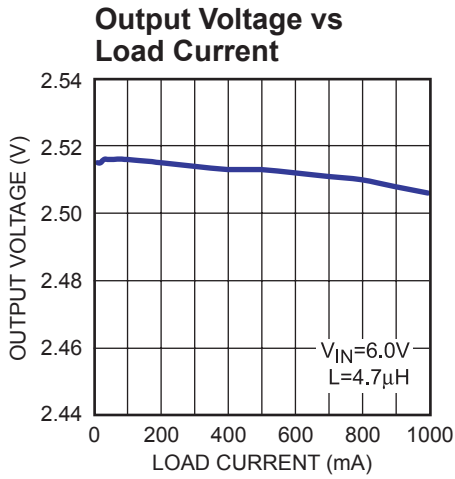

TYPICAL PERFORMANCE CHARACTERISTICS (continued)

$V_{OUT1} = 1.8V$, $V_{OUT2} = 1.2V$, $C1 = C2 = C3 = 10\mu F$, $C4 = 1nF$, $L1 = L2 = 2.2\mu H$ $T_A = +25^\circ C$, unless otherwise noted.

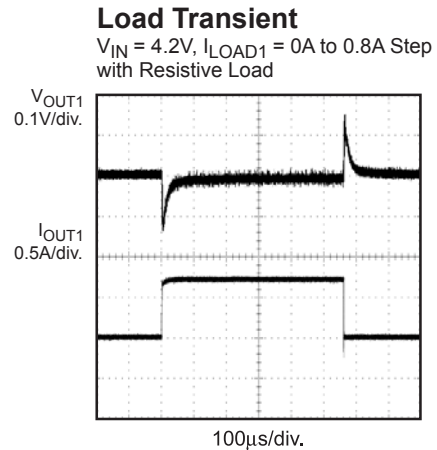
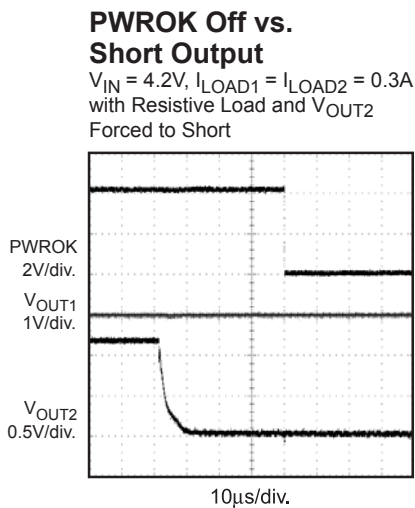
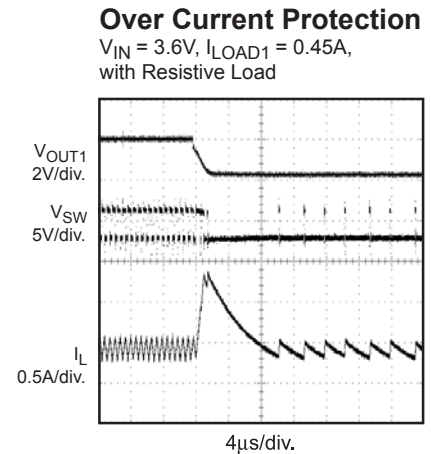
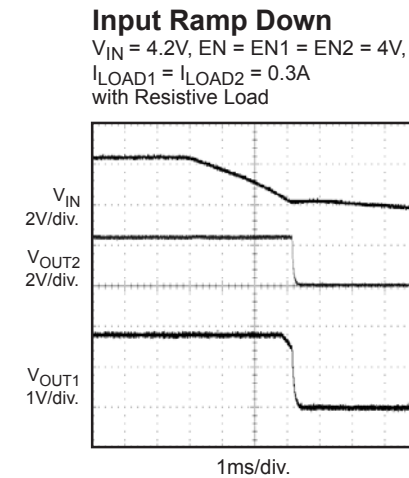
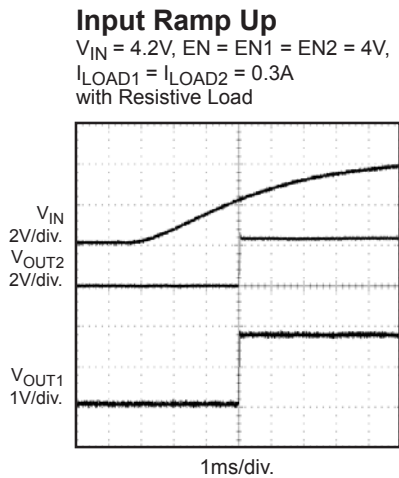
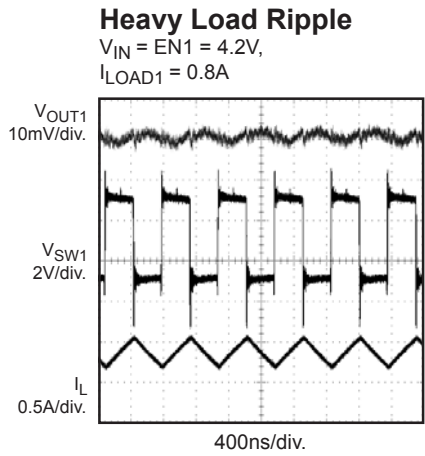
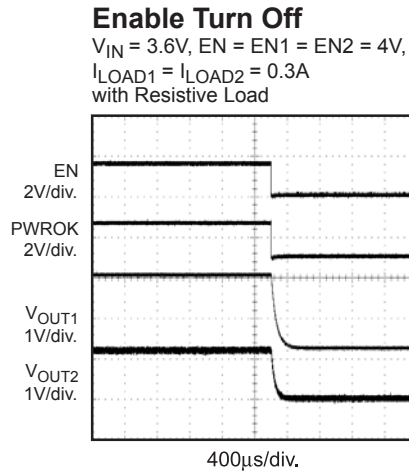
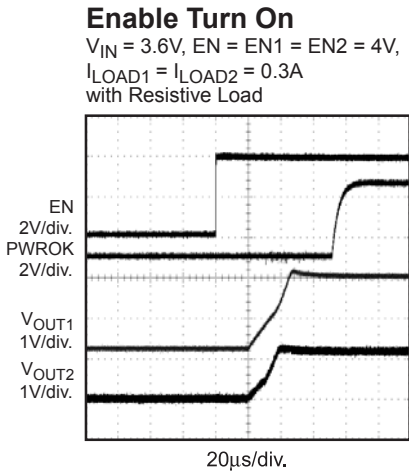

OPERATION

The MP2102 is a dual-channel constant frequency current mode PWM step-down converter. The MP2102 is optimized for low voltage, Li-Ion battery powered applications where high efficiency and small size are critical.

The MP2102 uses an external resistor divider to set the output voltage from 0.6V to 5.4V. The device integrates both a main switch and a synchronous rectifier which provides high efficiency and eliminates the need for an external Schottky diode.

Current Mode PWM Control

Slope compensated current mode PWM control provides stable switching and cycle-by-cycle current limit for superior load and line response and protection of the internal main switch and synchronous rectifier.

The MP2102 switches at a constant frequency (1.5MHz) and regulates the output voltage. During each cycle the PWM comparator modulates the power transferred to the load by changing the inductor peak current based on the feedback error voltage. During normal operation, the main switch is turned on for a certain time to ramp the inductor current at each rising edge of the internal oscillator, and switched off when the peak inductor current is above the error voltage.

When the main switch is off, the synchronous rectifier will be turned on immediately and stay on until the next cycle starts. The maximum duty cycle of the MP2102 is around 90%, therefore the maximum achievable output voltage is 90% of the input voltage minus the voltage drop across the main switch and the inductor.

Short Circuit Protection

The MP2102 has an independent short circuit protection for each channel. When the output is shorted to ground, the valley current limit control is activated; the next cycle of turning on the main switch will not start until the inductor current has dropped to below 300mA. The control mechanism will return to normal once the feedback voltage reaches 0.3V.

Output Power Good Indication

The open-drain pin PWROK is used to monitor the output condition. When the voltages of both outputs are within $\pm 10\%$ of the expected value, the open-drain device will turn off, floating the PWROK pin. When at least one of the outputs is outside of $\pm 10\%$ window, the PWROK will be pulled "LOW".

Power-On Reset Delay

The MP2102 has a programmable power on reset delay. Changing the value of the capacitor at the DLY pin sets the delay time. See Programming PWROK Delay in the Applications Information section.

Maximum Load Current

The MP2102 can operate down to 2.5V input voltage; however the maximum load current decreases at lower input due to large IR drop on the main switch and synchronous rectifier.

The slope compensation signal reduces the peak inductor current as a function of the duty cycle to prevent sub-harmonic oscillations at duty cycles greater than 50%. Conversely, the current limit increases as the duty cycle decreases.

BLOCK DIAGRAMS

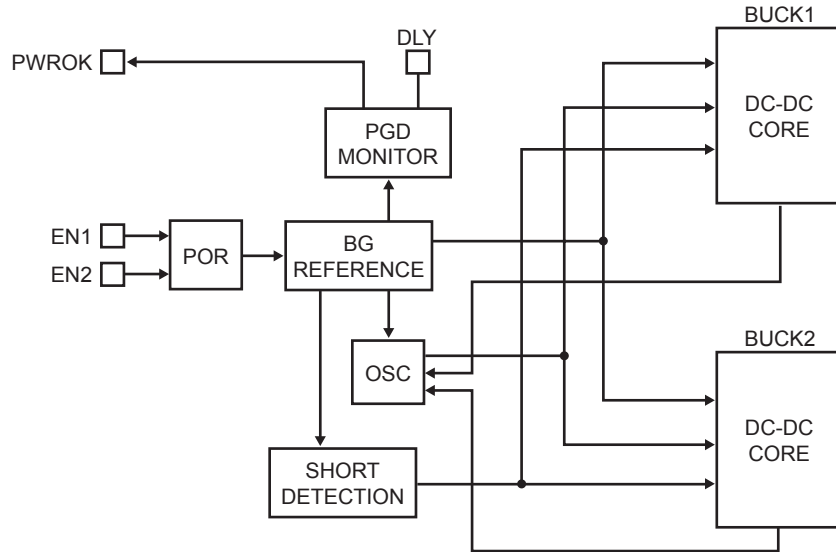

Figure 1—Dual Buck Functional Block Diagram

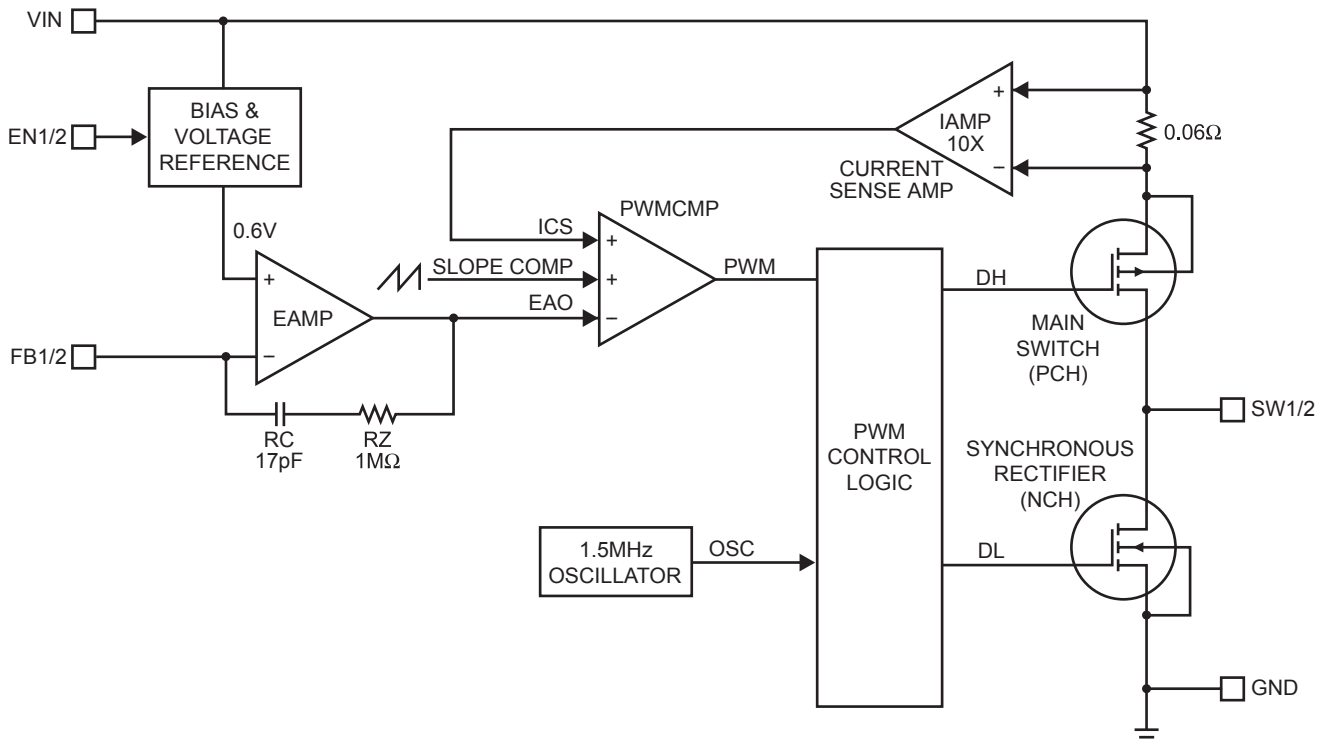

Figure 2—DC-DC Core Functional Block Diagram

APPLICATION INFORMATION

Output Voltage Setting

Please reference the schematic on the front page. The external resistor divider sets the output voltage. The top feedback resistor R_{TOP} also sets the feedback loop bandwidth with the internal compensation capacitor (see Typical Application circuit).

Choose R_{TOP} around 300k Ω for optimal transient response. The bottom feedback resistor R_{BOT} is then given by:

$$R_{BOT} = \frac{R_{TOP}}{\frac{V_{OUT}}{0.6V} - 1}$$

Where R_{TOP} is either R1 or R3, and R_{BOT} is either R2 or R4.

Table 1—Resistor Selection vs. Output Voltage Setting

V_{OUT}	R_{TOP}	R_{BOT}
1.2V	300k Ω (1%)	300k Ω (1%)
1.5V	300k Ω (1%)	200k Ω (1%)
1.8V	300k Ω (1%)	150k Ω (1%)
2.5V	300k Ω (1%)	95.3k Ω (1%)

Inductor Selection (L1, L2)

A 1 μ H to 10 μ H inductor with DC current rating at least 25% higher than the maximum load current is recommended for most applications. For best efficiency, the inductor DC resistance shall be <200m Ω . See Table 2 for recommended inductors and manufacturers. For most designs, the inductance value can be derived from the following equation:

$$L = \frac{V_{OUT} \times (V_{IN} - V_{OUT})}{V_{IN} \times \Delta I_L \times f_{OSC}}$$

Where ΔI_L is the inductor ripple current. Choose inductor ripple current approximately 30% of the maximum load current, 800mA.

The maximum inductor peak current is:

$$I_{L(MAX)} = I_{LOAD} + \frac{\Delta I_L}{2}$$

Under light load conditions below 100mA, larger inductance is recommended for improved efficiency. Table 3 lists inductors recommended for this purpose.

Programming PWROK Delay (C4)

Placing a larger capacitor at the DLY pin will increase the delay time. This can be calculated as:

$$t_{DELAY} = 500\mu s \times \frac{C4}{1nF}$$

Table 2—Suggested Surface Mount Inductors

Manufacturer	Part Number	Inductance (μ H)	Max DCR (Ω)	Saturation Current (A)	Dimensions LxWxH (mm ³)
Coilcraft	LP1704-222M	2.2	0.07	1.7	6.5x5.3x2
Toko	D312C	2.2	0.14	1.0	3.6x3.6x1
Sumida	CDRH3D16	2.2	0.072	1.2	4x4x1.8
Taiyo Yuden	LBC2518	2.2	0.13	0.6	2.5x1.8x1.8

Table 3—Inductors for Improved Efficiency at 25mA, 50mA, under 100mA Load.

Manufacturer	Part Number	Inductance (μ H)	Max DCR (Ω)	Saturation Current (A)	I_{RMS} (A)
Coilcraft	DO1605T-103MX	10	0.3	1.0	0.9
Murata	LQH4C100K04	10	0.2	1.2	0.8
Sumida	CMD4D06-100	10	0.3	0.7	0.5
Sumida	CR32-100	10	0.2	1.0	0.7
Sumida	CR54-100	10	0.1	1.2	1.4

Input Capacitor Selection (C1)

The input capacitor reduces the surge current drawn from the input and switching noise from the device. The input capacitor impedance at the switching frequency shall be less than input source impedance to prevent high frequency switching current passing to the input. Ceramic capacitors with X7R or X5R dielectrics are highly recommended because of their low ESR and small temperature coefficients. For most applications, a 4.7µF capacitor is sufficient.

Output Capacitor Selection (C2, C3)

The output capacitor keeps output voltage ripple small and ensures regulation loop stability. The output capacitor impedance shall be low at the switching frequency. Ceramic capacitors with X5R or X7R dielectrics are recommended. The output ripple ΔV_{OUT} is approximately:

$$\Delta V_{OUT} \leq \frac{V_{OUT} \times (V_{IN} - V_{OUT})}{V_{IN} \times f_{OSC} \times L} \times \left(ESR + \frac{1}{8 \times f_{OSC} \times C_{OUT}} \right)$$

Where C_{OUT} is C2 or C3.

Thermal Dissipation

Power dissipation shall be considered when both channels of the MP2102 provide maximum 800mA output current to the loads at high ambient temperature with low input supply voltage. If the junction temperature rises above 150°C, the MP2102 two channels will be shut down.

The junction-to-ambient thermal resistance of the 10-pin QFN (3mm x 3mm) $R_{\theta JA}$ is 50°C/W. Therefore, the maximum power dissipation is about 1.6W when the MP2102 is operating in a 70°C ambient temperature environment.

$$PD_{MAX} = \frac{150^{\circ}C - 70^{\circ}C}{50^{\circ}C / W} = 1.6W$$

PC Board Layout

The high current paths (GND, VIN and SW1/SW2) should be placed very close to the device with short, direct and wide traces. Input capacitors should be placed as close as possible to the VIN and GND pins. The external feedback resistors shall be placed next to the FB pins. Keep the switching nodes SW1/SW2 short and away from the feedback network.

PACKAGE INFORMATION

QFN10 (3mm x 3mm)

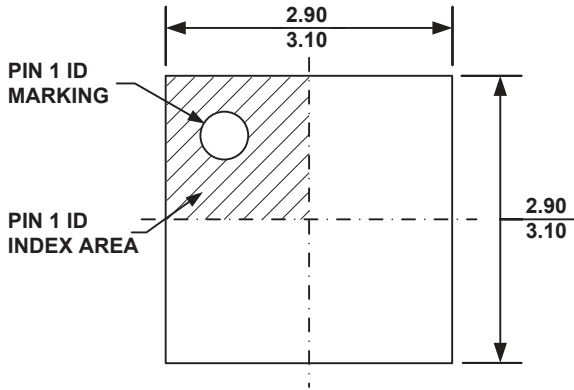

TOP VIEW

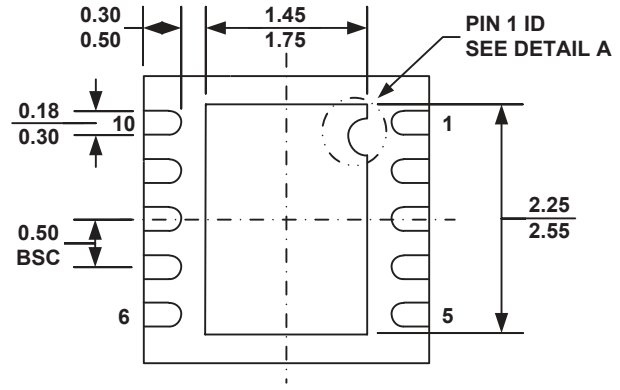

BOTTOM VIEW

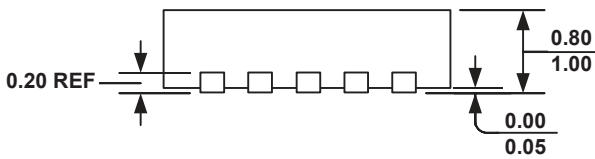

SIDE VIEW

PIN 1 ID OPTION A
R0.20 TYP.

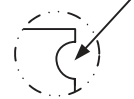

PIN 1 ID OPTION B
R0.20 TYP.



DETAIL A

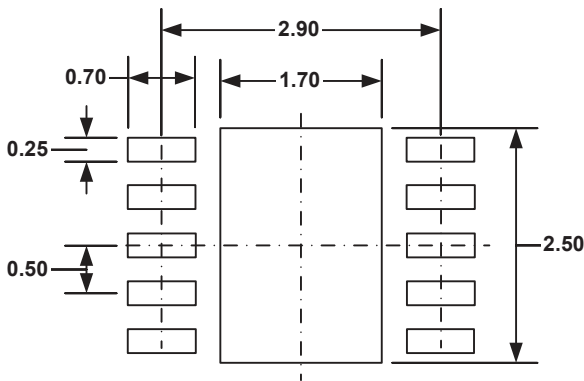

RECOMMENDED LAND PATTERN

NOTE:

- 1) ALL DIMENSIONS ARE IN MILLIMETERS.
- 2) EXPOSED PADDLE SIZE DOES NOT INCLUDE MOLD FLASH.
- 3) LEAD COPLANARITY SHALL BE 0.10 MILLIMETER MAX.
- 4) DRAWING CONFORMS TO JEDEC MO-229, VARIATION VEED-5.
- 5) DRAWING IS NOT TO SCALE.

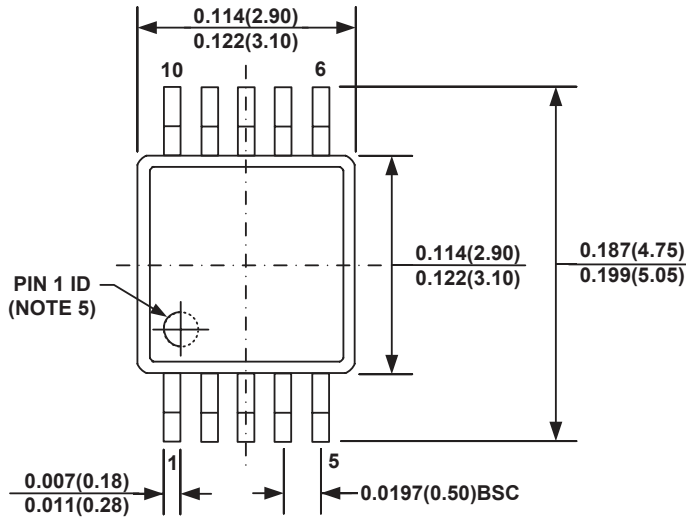
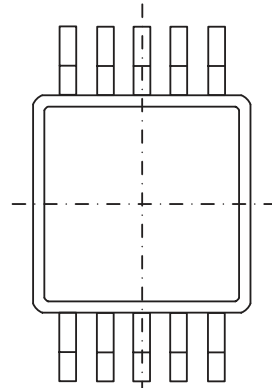
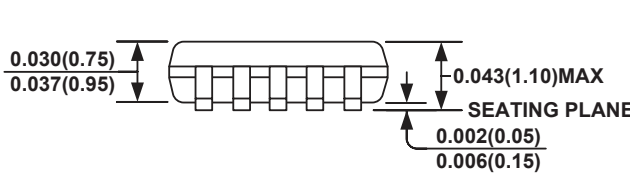
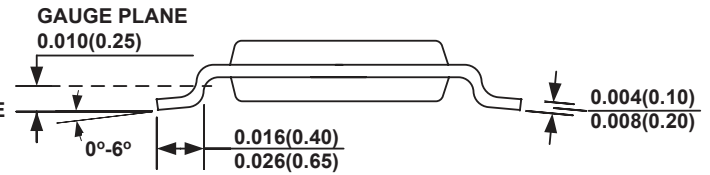
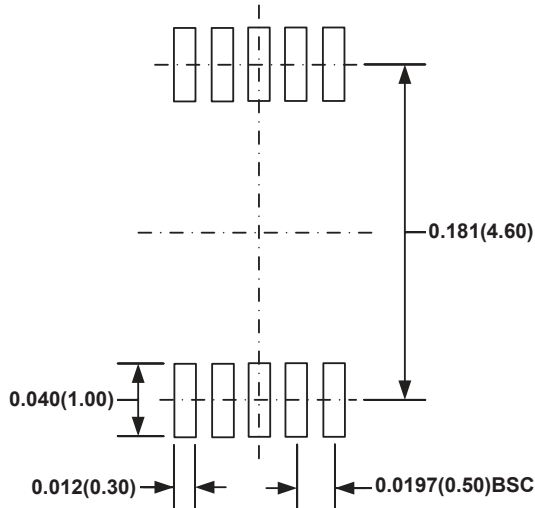
MSOP10

TOP VIEW

BOTTOM VIEW

FRONT VIEW

SIDE VIEW

RECOMMENDED LAND PATTERN
NOTE:

- 1) CONTROL DIMENSION IS IN INCHES. DIMENSION IN BRACKET IS IN MILLIMETERS.
- 2) PACKAGE LENGTH DOES NOT INCLUDE MOLD FLASH, PROTRUSION OR GATE BURR.
- 3) PACKAGE WIDTH DOES NOT INCLUDE INTERLEAD FLASH OR PROTRUSION.
- 4) LEAD COPLANARITY (BOTTOM OF LEADS AFTER FORMING) SHALL BE 0.004" INCHES MAX.
- 5) PIN 1 IDENTIFICATION HAS THE HALF OR FULL CIRCLE OPTION.
- 6) DRAWING MEETS JEDEC MO-817, VARIATION BA.
- 7) DRAWING IS NOT TO SCALE.

NOTICE: The information in this document is subject to change without notice. Users should warrant and guarantee that third party Intellectual Property rights are not infringed upon when integrating MPS products into any application. MPS will not assume any legal responsibility for any said applications.

Looking for pricing, stock, or lifecycle information?

Click below to explore more details on WIN SOURCE:

- [View MP2102DK-LF-Z on WIN SOURCE](#)
- [Monolithic Power Systems Inc. Information](#)

Optimize Your Supply Chain with WIN SOURCE Solutions

- ✓ Global Sourcing Solution
- ✓ Obsolete Management
- ✓ Cost Control Management
- ✓ Shortage Management
- ✓ Alternative Solution
- ✓ Excess Inventory Management