



**THE DATASHEET OF
MPXA6115AC6U**



MPXxx6115A, 15 to 115 kPa, Absolute, Integrated Pressure Sensor

The MPXxx6115A series sensor integrates on-chip, bipolar op amp circuitry and thin film resistor networks to provide a high output signal and temperature compensation. The small form factor and high reliability of on-chip integration make the pressure sensor a logical and economical choice for the system designer.

The MPXxx6115A series piezoresistive transducer is a state-of-the-art, monolithic, signal conditioned, silicon pressure sensor. This sensor combines advanced micromachining techniques, thin film metallization, and bipolar semiconductor processing to provide an accurate, high level analog output signal that is proportional to applied pressure.

Features

- Resistant to high humidity and common automotive media
- Improved accuracy at high temperature
- Available in small and super small outline packages
- 1.5% maximum error over 0 °C to 85 °C
- Ideally suited for microprocessor or microcontroller-based systems
- Temperature compensated from -40 °C to +125 °C
- Durable Thermoplastic (PPS) Surface Mount Package

Typical applications

- Industrial controls
- Engine control/manifold absolute pressure (MAP)
- Weather station and weather reporting device barometers

**MPXA6115A
MPXAZ6115A
MPXH6115A
MPXHZ6115A
Series**

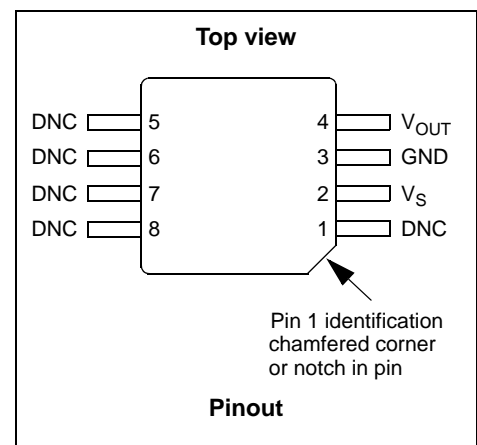

Small outline packages

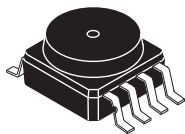

MPXA6115A6U/T1
Case 98ASB17756C

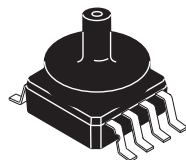

MPXA6115AC6U/T1
MPXAZ6115AC6T1
Case 98ASB17757C

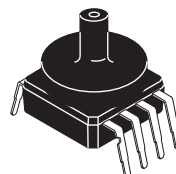

MPXA6115AC7U
Case 98ASB17759C

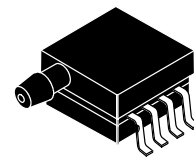

MPXAZ6115AP/T1
Case 98ASA99303D

Super small outline packages

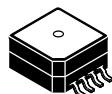

MPXH6115A6U/T1
MPXHZ6115A6U/T1
Case 98ARH99066A

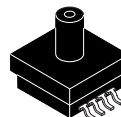

MPXH6115AC6U/T1
MPXHZ6115AC6U/T1
Case 98ARH99089A

Freescale reserves the right to change the detail specifications as may be required to permit improvements in the design of its products.

© 2007-2012, 2015 Freescale Semiconductor, Inc. All rights reserved.

Ordering information									
Device name	Shipping	Package	# of Ports			Pressure type			Device marking
			None	Single	Dual	Gauge	Differential	Absolute	
Small outline package (MPXA6115A series)									
MPXA6115A6U	Rails	98ASB17756C	•					•	MPXA6115A
MPXA6115A6T1	Tape and Reel	98ASB17756C	•					•	MPXA6115A
MPXA6115AC6U	Rails	98ASB17757C		•				•	MPXA6115A
MPXA6115AC6T1	Tape and Reel	98ASB17757C		•				•	MPXA6115A
MPXA6115AC7U	Rails	98ASB17759C		•				•	MPXA6115A
Small outline package (Media resistant gel) (MPXAZ6115A series)									
MPXAZ6115AC6T1	Tape and Reel	98ASB17757C		•				•	MPXAZ6115A
MPXAZ6115AP	Trays	98ASA99303D		•				•	MPXAZ6115A
MPXAZ6115APT1	Tape and Reel	98ASA99303D		•				•	MPXAZ6115A
Super small outline package (MPXH6115A series)									
MPXH6115A6U	Rails	98ARH99066A	•					•	MPXH6115A
MPXH6115A6T1	Tape and Reel	98ARH99066A	•					•	MPXH6115A
MPXH6115AC6U	Rails	98ARH99089A		•				•	MPXH6115A
MPXH6115AC6T1	Tape and Reel	98ARH99089A		•				•	MPXH6115A
Small outline package (Media resistant gel) (MPXHZ6115A series)									
MPXHZ6115A6U	Rails	98ARH99066A	•					•	MPXHZ6115A
MPXHZ6115A6T1	Tape and Reel	98ARH99066A	•					•	MPXHZ6115A
MPXHZ6115AC6U	Rails	98ARH99089A		•				•	MPXHZ6115A
MPXHZ6115AC6T1	Tape and Reel	98ARH99089A		•				•	MPXHZ6115A



Contents

1	General Description	4
1.1	Block diagram	4
1.2	Pinout	4
2	Mechanical and Electrical Specifications	5
2.1	Maximum ratings	5
2.2	Operating characteristics	5
3	On-chip Temperature Compensation and Calibration	6
4	Package Information	8
4.1	Minimum recommended footprint for small and super small packages	8
4.2	Package dimensions	9
5	Revision History	19

Related Documentation

The MPXxx6115A device features and operations are described in a variety of reference manuals, user guides, and application notes. To find the most-current versions of these documents:

1. Go to the Freescale homepage at:
<http://www.freescale.com/>
2. In the Keyword search box at the top of the page, enter the device number MPXxx6115A.
3. In the Refine Your Result pane on the left, click on the Documentation link.

MPXA6115A

1 General Description

1.1 Block diagram

Figure 1 shows a block diagram of the internal circuitry integrated on a pressure sensor chip.

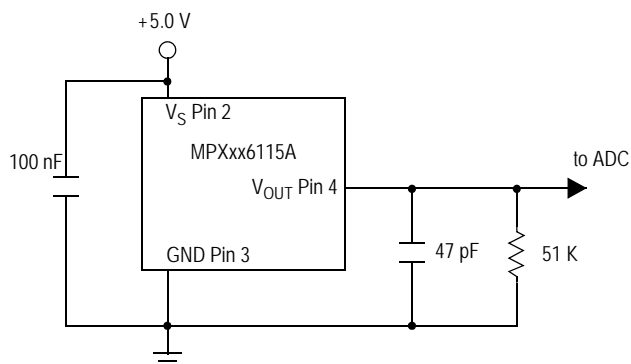
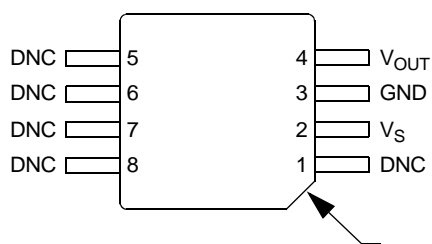

Figure 1. Fully integrated pressure sensor schematic

1.2 Pinout



Pin 1 identification, chamfered corner or notch in pin

Figure 2. Device pinout (top view)

Table 1. Pin functions

Pin	Name	Function
1	DNC	Do not connect to external circuitry or ground. Pin 1 is denoted by chamfered corner.
2	V_S	Voltage supply
3	GND	Ground
4	V_{OUT}	Output voltage
5	DNC	Do not connect to external circuitry or ground.
6	DNC	Do not connect to external circuitry or ground.
7	DNC	Do not connect to external circuitry or ground.
8	DNC	Do not connect to external circuitry or ground.

2 Mechanical and Electrical Specifications

2.1 Maximum ratings

Table 2. Maximum ratings⁽¹⁾

Rating	Symbol	Value	Units
Maximum pressure (P1 > P2)	P_{max}	400	kPa
Storage temperature	T_{stg}	-40° to +125°	°C
Operating temperature	T_A	-40° to +125°	°C
Output source current @ full-scale output ⁽²⁾	I_{o+}	0.5	mAdc
Output sink current @ minimum pressure offset ⁽²⁾	I_{o-}	-0.5	mAdc

1.Exposure beyond the specified limits may cause permanent damage or degradation to the device.

2.Maximum output current is controlled by effective impedance from V_{OUT} to GND or V_{OUT} to V_S in the application circuit.

2.2 Operating characteristics

Table 3. Operating characteristics ($V_S = 5.0$ Vdc, $T_A = 25$ °C unless otherwise noted, P1 > P2)

Characteristic	Symbol	Min	Typ	Max	Unit
Pressure range	P_{OP}	15	—	115	kPa
Supply voltage ⁽¹⁾	V_S	4.75	5.0	5.25	Vdc
Supply current	I_o	—	6.0	10	mAdc
Minimum pressure offset ⁽²⁾ (0 °C to 85° C) @ $V_S = 5.0$ Volts	V_{off}	0.133	0.200	0.268	Vdc
Full-scale output ⁽³⁾ (0 °C to 85° C) @ $V_S = 5.0$ Volts	V_{FSO}	4.633	4.700	4.768	Vdc
Full-scale span ⁽⁴⁾ (0 °C to 85° C) @ $V_S = 5.0$ Volts	V_{FSS}	4.433	4.500	4.568	Vdc
Accuracy ⁽⁵⁾ (0 °C to 85° C)	—	—	—	±1.5	% V_{FSS}
Sensitivity	V/P	—	45.0	—	mV/kPa
Response time ⁽⁶⁾	t_R	—	1.0	—	ms
Warm-up time ⁽⁷⁾	—	—	20	—	ms
Offset stability ⁽⁸⁾	—	—	±0.25	—	% V_{FSS}

1.Device is ratiometric within this specified excitation range.

2.Offset (V_{off}) is defined as the output voltage at the minimum rated pressure.

3.Full-scale output (V_{FSO}) is defined as the output voltage at the maximum or full-rated pressure.

4.Full-scale span (V_{FSS}) is defined as the algebraic difference between the output voltage at full-rated pressure and the output voltage at the minimum rated pressure.

5.Accuracy is the deviation in actual output from nominal output over the entire pressure range and temperature range as a percent of span at 25 °C due to all sources of error including the following:

Linearity: Output deviation from a straight line relationship with pressure over the specified pressure range.

Temperature Hysteresis: Output deviation at any temperature within the operating temperature range, after the temperature is cycled to and from the minimum or maximum operating temperature points, with zero differential pressure applied.

Pressure Hysteresis: Output deviation at any pressure within the specified range, when this pressure is cycled to and from minimum or maximum rated pressure at 25 °C.

TcSpan: Output deviation over the temperature range of 0 °C to 85 °C, relative to 25 °C.

TcOffset: Output deviation with minimum pressure applied, over the temperature range of 0 °C to 85 °C, relative to 25 °C.

6.Response time is defined as the time for the incremental change in the output to go from 10% to 90% of its final value when subjected to a specified step change in pressure.

7.Warm-up time is defined as the time required for the product to meet the specified output voltage after the pressure has been stabilized.

8.Offset stability is the product's output deviation when subjected to 1000 cycles of pulsed pressure, temperature cycling with bias test.

3 On-chip Temperature Compensation and Calibration

Figure 3 illustrates the absolute sensing chip in the basic super small outline chip carrier (case 98ARH99066A).

Figure 4 shows a typical application circuit (output source current operation).

Figure 5 shows the sensor output signal relative to pressure input. Typical minimum and maximum output curves are shown for operation over 0 °C to 85 °C temperature range. The output will saturate outside of the rated pressure range.

A fluorosilicone gel isolates the die surface and wire bonds from the environment, while allowing the pressure signal to be transmitted to the silicon diaphragm. The MPXxx6115A series pressure sensor operating characteristics, internal reliability and qualification tests are based on use of dry air as the pressure media. Media other than dry air may have adverse effects on sensor performance and long-term reliability. Contact the factory for information regarding media compatibility in your application.

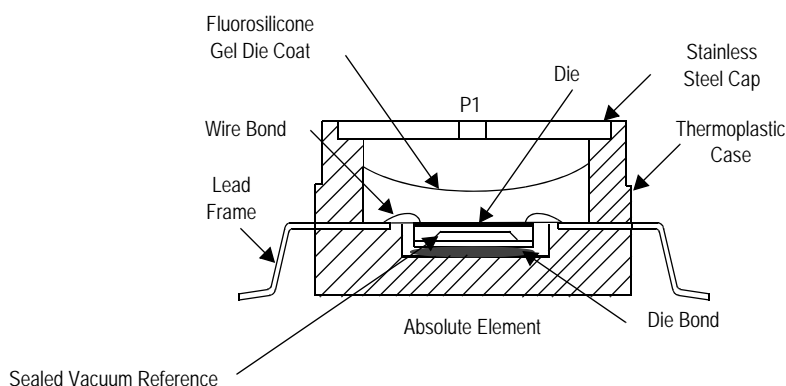

Figure 3. Cross Sectional Diagram SSOP/SOP (not to scale)

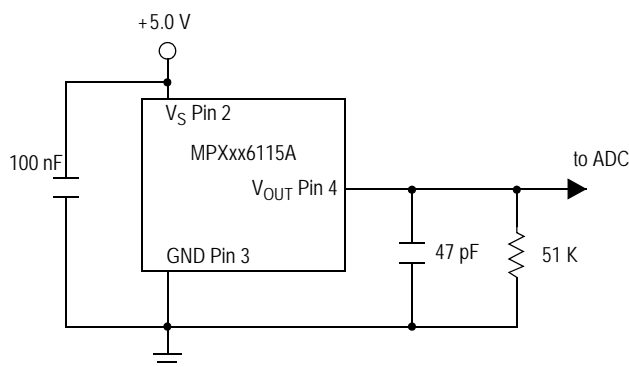

Figure 4. Typical application circuit (output source current operation)

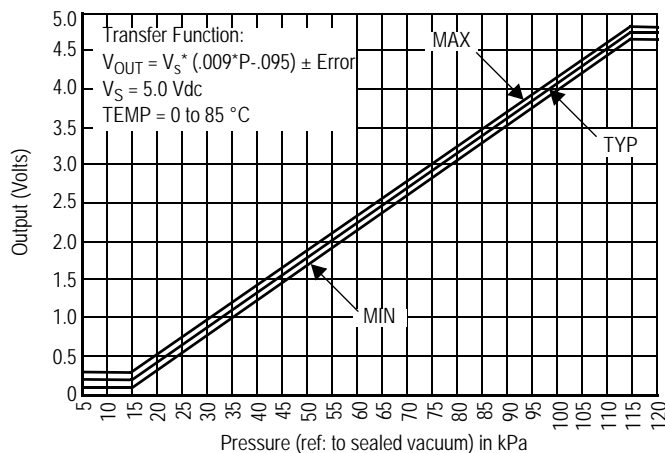
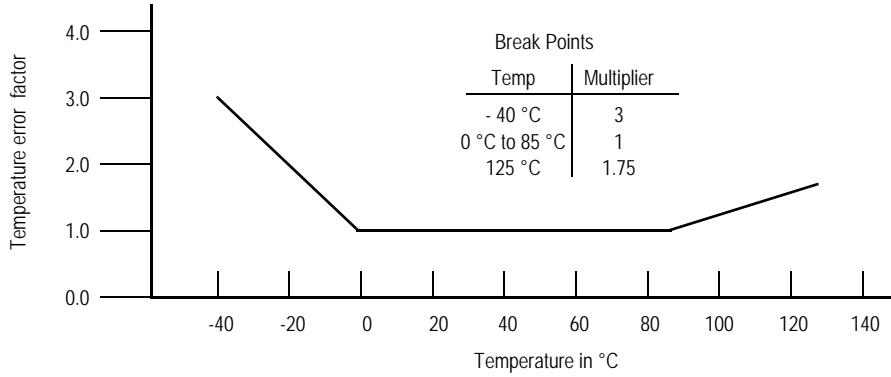

Figure 5. Output vs. absolute pressure

Nominal Transfer Value: $V_{OUT} = V_S \times (0.009 \times P - 0.095)$
 $\pm (\text{Pressure Error} \times \text{Temp. Factor} \times 0.009 \times V_S)$
 $V_S = 5.0 \pm 0.25 \text{ Vdc}$

Figure 6. Transfer function



NOTE: The Temperature Multiplier is a linear response from 0 °C to -40 °C and from 85 °C to 125 °C

Figure 7. Temperature error band

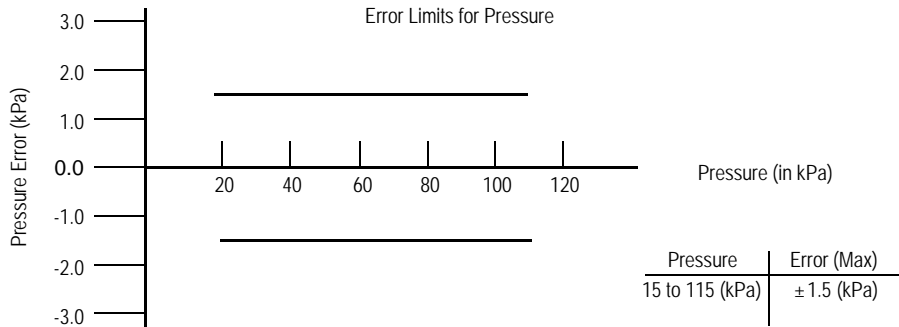

Figure 8. Pressure error band

4 Package Information

4.1 Minimum recommended footprint for small and super small packages

Surface mount board layout is a critical portion of the total design. The footprint for the semiconductor package must be the correct size to ensure proper solder connection interface between the board and the package. With the correct pad geometry, the packages will self-align when subjected to a solder reflow process. It is always recommended to fabricate boards with a solder mask layer to avoid bridging and/or shorting between solder pads, especially on tight tolerances and/or tight layouts.

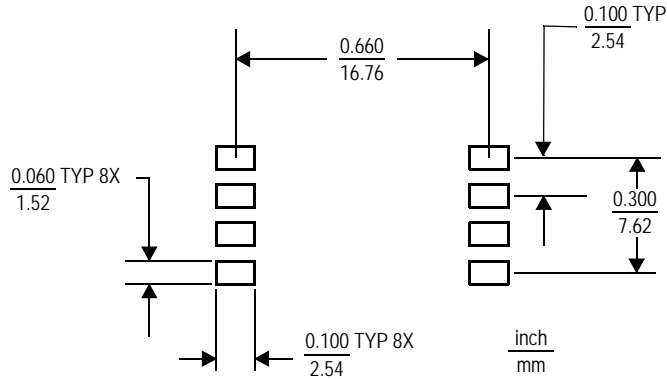

Figure 9. SOP Footprint (Case 98ASB17756C)

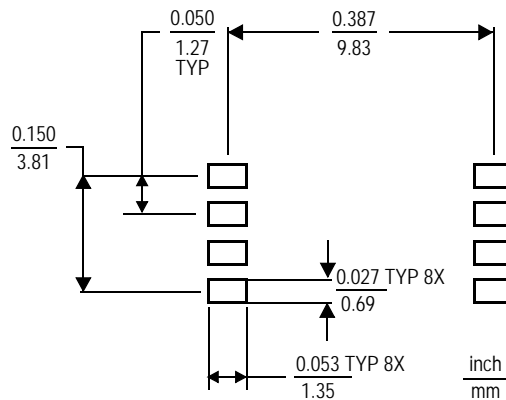
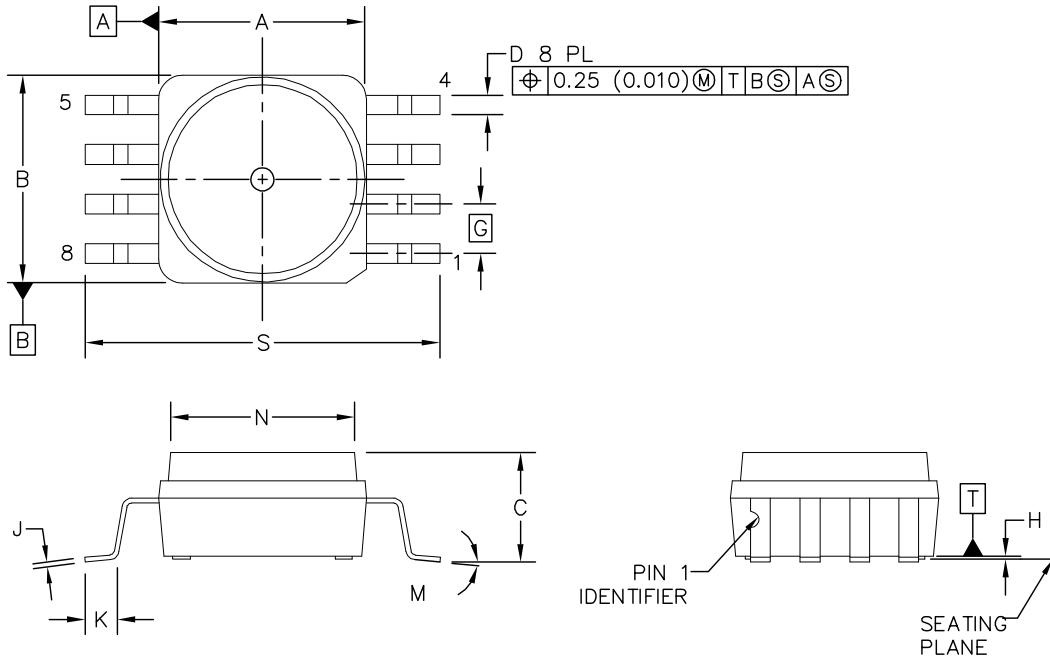

Figure 10. SSOP Footprint (Case 98ARH99066A and 98ARH99089A)

4.2 Package dimensions

This drawing is located at http://cache.freescale.com/files/shared/doc/package_info/98ASB17756C.pdf.



DIM	MILLIMETERS		INCHES	
	MIN	MAX	MIN	MAX
A	10.54	10.79	0.415	0.425
B	10.54	10.79	0.415	0.425
C	5.38	5.84	0.212	0.230
D	0.96	1.07	0.038	0.042
G	2.54 BSC		0.100 BSC	
H	0.05	0.25	0.002	0.010
J	0.23	0.28	0.009	0.011
K	1.55	1.80	0.061	0.071
M	0°	7°	0°	7°
N	10.29	10.54	0.405	0.415
S	18.01	18.41	0.709	0.725

NOTES:

1. DIMENSIONING AND TOLERANCING PER ASME Y14.5M, 1994
2. CONTROLLING DIMENSION: INCH.
3. DIMENSION "A" AND "B" DO NOT INCLUDE MOLD PROTRUSION.
4. MAXIMUM MOLD PROTRUSION 0.15 (0.006).
5. ALL VERTICAL SURFACES 5° TYPICAL DRAFT.

© FREESCALE SEMICONDUCTOR, INC. ALL RIGHTS RESERVED.	MECHANICAL OUTLINE	PRINT VERSION NOT TO SCALE
TITLE: 8 LD SENSOR SOP	DOCUMENT NO: 98ASB17756C	REV: A
	STANDARD: NON-JEDEC	
10 JAN 2013		

Case 98ASB17756C, Small outline package

MPXA6115A

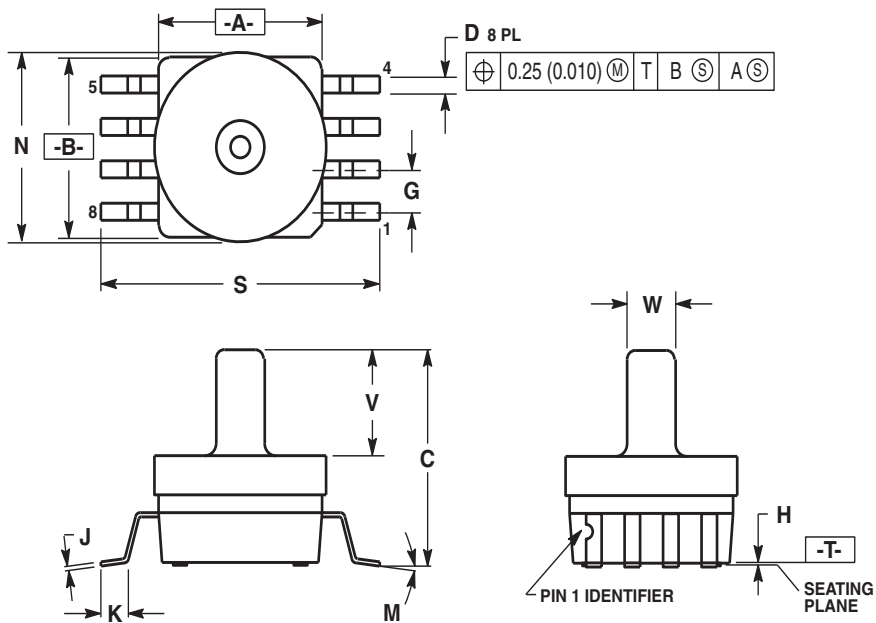

- NOTES:
1. DIMENSIONING AND TOLERANCING PER ANSI Y14.5M, 1982.
 2. CONTROLLING DIMENSION: INCH.
 3. DIMENSION A AND B DO NOT INCLUDE MOLD PROTRUSION.
 4. MAXIMUM MOLD PROTRUSION 0.15 (0.006).
 5. ALL VERTICAL SURFACES 5° TYPICAL DRAFT.

DIM	INCHES		MILLIMETERS	
	MIN	MAX	MIN	MAX
A	0.415	0.425	10.54	10.79
B	0.415	0.425	10.54	10.79
C	0.500	0.520	12.70	13.21
D	0.038	0.042	0.96	1.07
G	0.100 BSC		2.54 BSC	
H	0.002	0.010	0.05	0.25
J	0.009	0.011	0.23	0.28
K	0.061	0.071	1.55	1.80
M	0"	7"	0"	7"
N	0.444	0.448	11.28	11.38
S	0.709	0.725	18.01	18.41
V	0.245	0.255	6.22	6.48
W	0.115	0.125	2.92	3.17

Case 98ASB17757C, small outline package

FREESCALE	MECHANICAL OUTLINES DICTIONARY	98ASB17759C	
		PAGE	482C
DO NOT SCALE THIS DWG	ALL APPROVAL SIGNATURES ON FILE IN DOCUMENT CENTRAL	ISSUE	D SHEET 1 OF 2

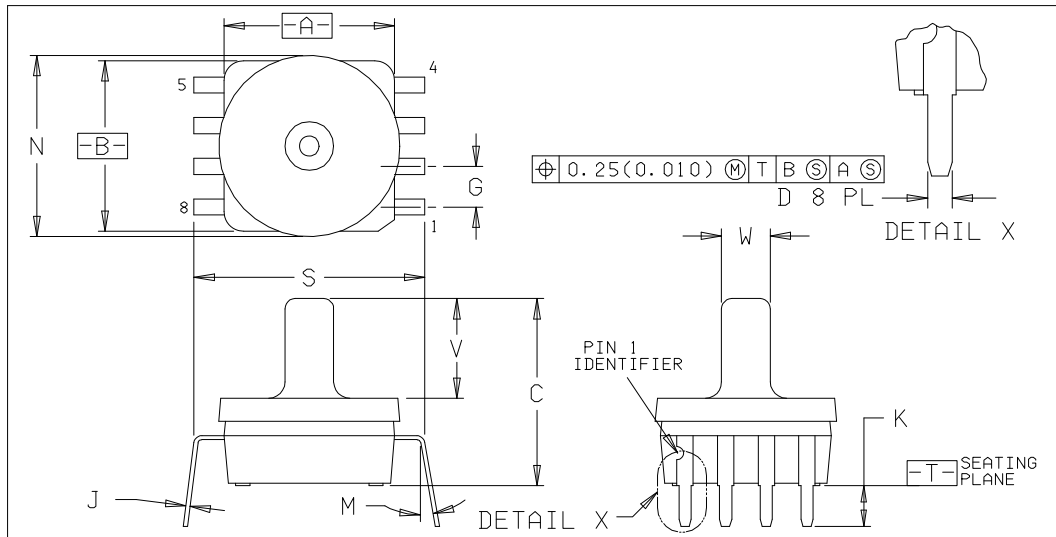

DIM	MILLIMETERS		INCHES	
	MIN	MAX	MIN	MAX
A	10.54	10.79	0.415	0.425
B	10.54	10.79	0.415	0.425
C	12.70	13.21	0.500	0.520
D	0.66	0.864	0.026	0.034
G	2.54 BSC		0.100 BSC	
J	0.23	0.28	0.009	0.011
K	2.54	3.05	0.100	0.120
M	0°	15°	0°	15°
N	11.28	11.38	0.444	0.448
S	13.72	14.22	0.540	0.560
V	6.22	6.48	0.245	0.255
W	2.92	3.17	0.115	0.125

- NOTES:
1. DIMENSIONING AND TOLERANCING PER ANSI Y14.5M, 1982.
 2. CONTROLLING DIMENSION: INCH.
 3. DIMENSION 'A' AND 'B' DO NOT INCLUDE MOLD PROTRUSION.
 4. MAXIMUM MOLD PROTRUSION 0.15(0.006).
 5. ALL VERTICAL SURFACES 5° TYPICAL DRAFT.
 6. DIMENSION 'S' TO CENTER OF LEAD WHEN FORMED PARALLEL.
 7. 482C-01 AND -02 OBSOLETE. NEW STANDARD 482C-03.

CASE NO.	482C-03
STATUS	MOTOROLA STANDARD
NEW STD	
USED ON	

ELECTRONIC VERSIONS ARE UNCONTROLLED EXCEPT WHEN ACCESSED DIRECTLY FROM WWCN.
PRINTED VERSIONS ARE UNCONTROLLED, EXCEPT WHEN STAMPED "CONTROLLED COPY" IN RED.

Case 98ASB17759C, small outline package

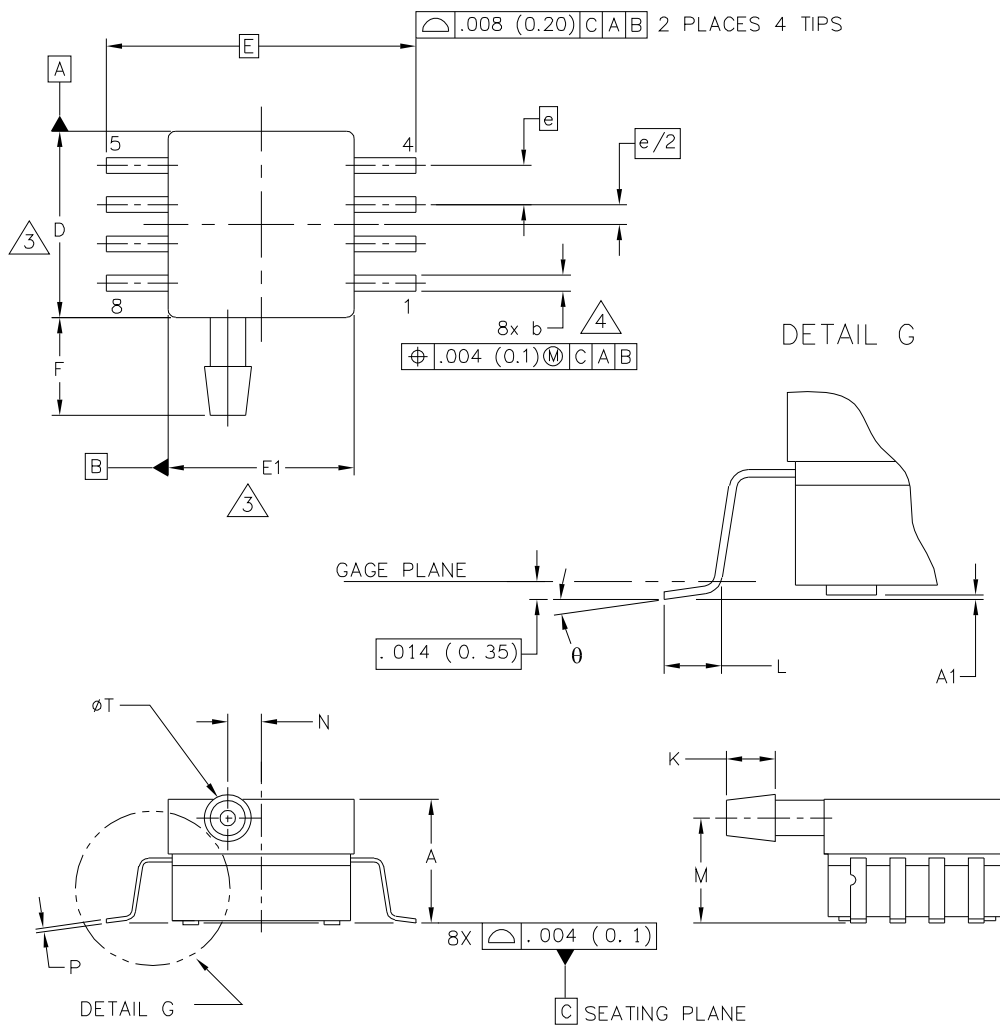

© FREESCALE SEMICONDUCTOR, INC. ALL RIGHTS RESERVED.	MECHANICAL OUTLINE	PRINT VERSION NOT TO SCALE	
TITLE: 8 LD SOP, SIDE PORT	DOCUMENT NO: 98ASA99303D	REV: D	
	CASE NUMBER: 1369-01	13 DEC 2010	
	STANDARD: NON-JEDEC		



NOTES:

1. CONTROLLING DIMENSION: INCH
2. INTERPRET DIMENSIONS AND TOLERANCES PER ASME Y14.5M-1994.
3. DIMENSIONS DO NOT INCLUDE MOLD FLASH OR PROTRUSIONS.
MOLD FLASH AND PROTRUSIONS SHALL NOT EXCEED .006 (0.152) PER SIDE.
4. DIMENSION DOES NOT INCLUDE DAMBAR PROTRUSION. ALLOWABLE DAMBAR PROTRUSION SHALL BE .008 (0.203) MAXIMUM.

DIM	INCHES		MILLIMETERS		DIM	INCHES		MILLIMETERS	
	MIN	MAX	MIN	MAX		MIN	MAX	MIN	MAX
A	.300	.330	7.62	8.38	θ	0°	7°	0°	7°
A1	.002	.010	0.05	0.25	-	---	---	---	---
b	.038	.042	0.96	1.07	-	---	---	---	---
D	.465	.485	11.81	12.32	-	---	---	---	---
E	.717 BSC		18.21 BSC		-	---	---	---	---
E1	.465	.485	11.81	12.32	-	---	---	---	---
e	.100 BSC		2.54 BSC		-	---	---	---	---
F	.245	.255	6.22	6.47	-	---	---	---	---
K	.120	.130	3.05	3.30	-	---	---	---	---
L	.061	.071	1.55	1.80	-	---	---	---	---
M	.270	.290	6.86	7.36	-	---	---	---	---
N	.080	.090	2.03	2.28	-	---	---	---	---
P	.009	.011	0.23	0.28	-	---	---	---	---
T	.115	.125	2.92	3.17	-	---	---	---	---
© FREESCALE SEMICONDUCTOR, INC. ALL RIGHTS RESERVED.			MECHANICAL OUTLINE			PRINT VERSION NOT TO SCALE			
TITLE: 8 LD SOP, SIDE PORT					DOCUMENT NO: 98ASA99303D			REV: D	
					CASE NUMBER: 1369-01			13 DEC 2010	
					STANDARD: NON-JEDEC				

PAGE 2 OF 2

Case 98ASA99303D, Small outline package

MPXA6115A

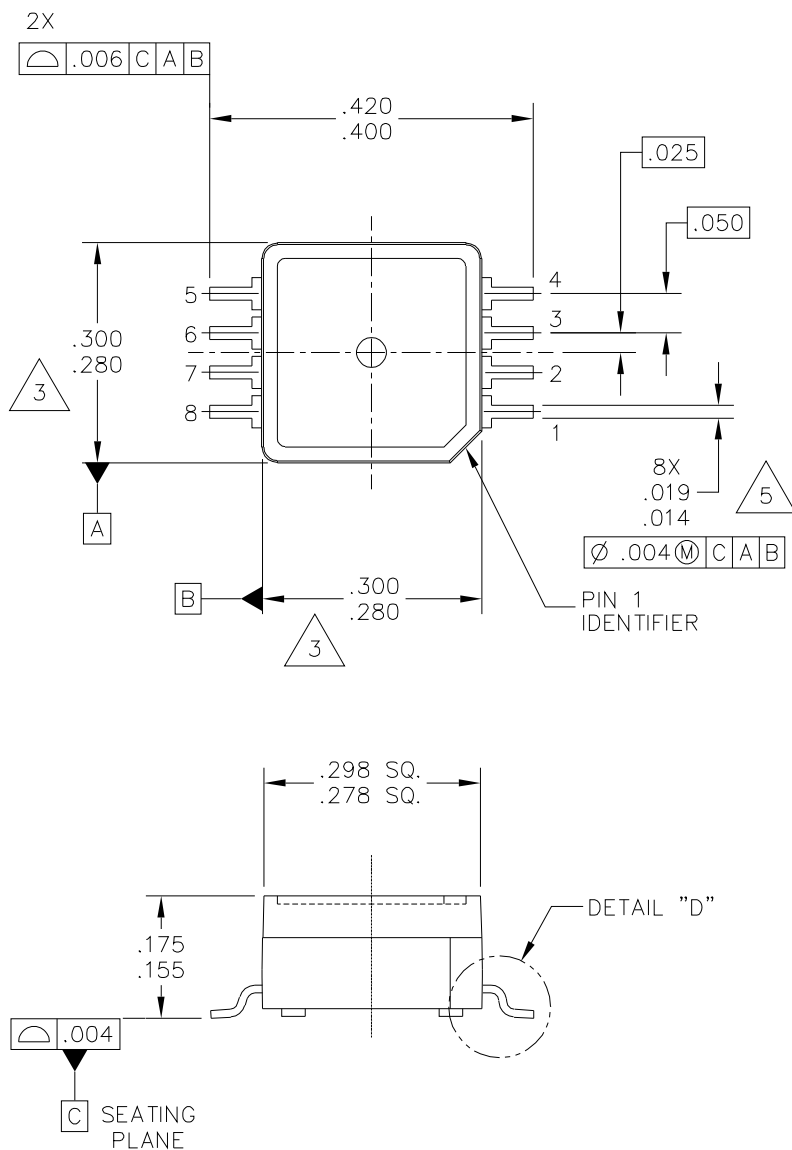

© FREESCALE SEMICONDUCTOR, INC. ALL RIGHTS RESERVED.		MECHANICAL OUTLINE		PRINT VERSION NOT TO SCALE	
TITLE: 8 LEAD SSOP		DOCUMENT NO: 98ARH99066A		REV: H	
		CASE NUMBER: 1317-04		13 APR 2012	
		STANDARD: NON-JEDEC			

Case 98ARH99066A, Super small outline package

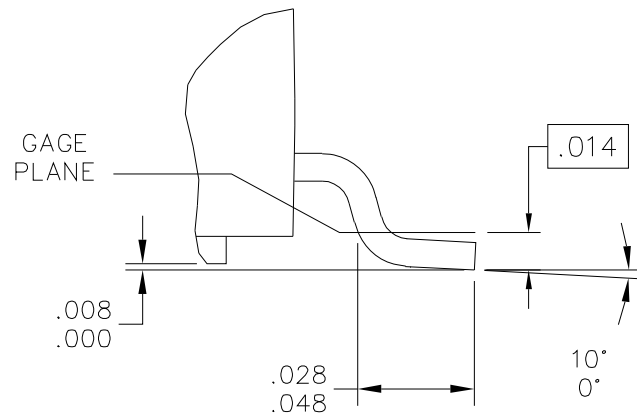

DETAIL "D"

© FREESCALE SEMICONDUCTOR, INC. ALL RIGHTS RESERVED.		MECHANICAL OUTLINE		PRINT VERSION NOT TO SCALE	
TITLE:	8 LEAD SSOP	DOCUMENT NO: 98ARH99066A		REV: H	
		CASE NUMBER: 1317-04		13 APR 2012	
		STANDARD: NON-JEDEC			

PAGE 2 OF 3

Case 98ARH99066A, Super small outline package



NOTES:

- 1. ALL DIMENSIONS IN INCHES.
- 2. DIMENSIONING AND TOLERANCING PER ASME Y14.5M-1994.
- 3. DIMENSIONS DO NOT INCLUDE MOLD FLASH OR PROTRUSIONS.
MOLD FLASH OR PROTRUSION SHALL NOT EXCEED .006 INCHES PER SIDE.
- 4. ALL VERTICAL SURFACES TO BE 5° MAXIMUM.
- 5. DIMENSION DOES NOT INCLUDE DAMBAR PROTRUSION.
ALLOWABLE DAMBAR PROTRUSION SHALL BE .008 INCHES MAXIMUM.

© FREESCALE SEMICONDUCTOR, INC. ALL RIGHTS RESERVED.	MECHANICAL OUTLINE	PRINT VERSION NOT TO SCALE	
TITLE: 8 LEAD SSOP		DOCUMENT NO: 98ARH99066A	REV: H
		CASE NUMBER: 1317-04	13 APR 2012
		STANDARD: NON-JEDEC	

PAGE 3 OF 3

Case 98ARH99066A, Super small outline package

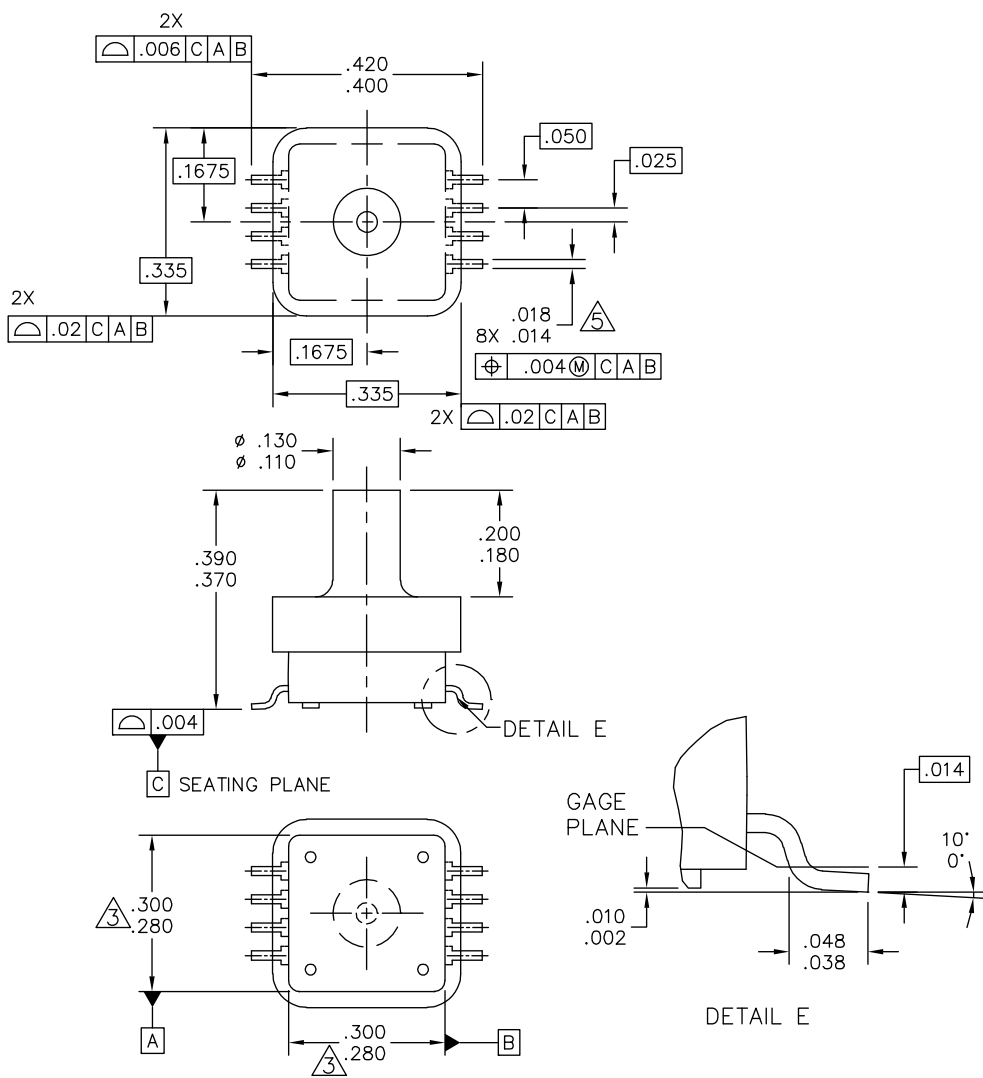

© FREESCALE SEMICONDUCTOR, INC. ALL RIGHTS RESERVED.	MECHANICAL OUTLINE	PRINT VERSION NOT TO SCALE	
TITLE: 8 LD, PORTED SSOP	DOCUMENT NO: 98ARH99089A	REV: D	
	CASE NUMBER: 1317A-04	26 OCT 2006	
	STANDARD: NON-JEDEC		



NOTES:

1. ALL DIMENSIONS IN INCHES.
2. DIMENSIONING AND TOLERANCING PER ASME Y14.5M-1994.
3. DIMENSIONS DO NOT INCLUDE MOLD FLASH OR PROTRUSIONS.
MOLD FLASH OR PROTRUSION SHALL NOT EXCEED .006 INCHES PER SIDE.
4. ALL VERTICAL SURFACES TO BE 5° MAXIMUM.
5. DIMENSION DOES NOT INCLUDE DAMBAR PROTRUSION.
ALLOWABLE DAMBAR PROTRUSION SHALL BE .008 INCHES MAXIMUM.

© FREESCALE SEMICONDUCTOR, INC. ALL RIGHTS RESERVED.	MECHANICAL OUTLINE	PRINT VERSION NOT TO SCALE	
TITLE: 8 LD, PORTED SSOP	DOCUMENT NO: 98ARH99089A	REV: D	
	CASE NUMBER: 1317A-04	26 OCT 2006	
	STANDARD: NON-JEDEC		

PAGE 2 OF 2

Case 98ARH99089A, Super small outline package

5 Revision History

Table 4. Revision history

Revision number	Revision date	Description of changes
7.1	05/2012	<ul style="list-style-type: none"> • Updated Package Drawing 98ARH99066A was Rev. F, updated to Rev. H,
7.2	10/2012	<ul style="list-style-type: none"> • On page 1, changed typical output voltage from 4.8V to 4.7V to match typical output voltage listed on page 3 of document
7.3	04/2015	<ul style="list-style-type: none"> • Removed obsolete part numbers MPXAZ6115A6U and MPXAZ6115AC6U from data sheet. • Updated format.



How to Reach Us:

Home Page:

freescale.com

Web Support:

freescale.com/support

Information in this document is provided solely to enable system and software implementers to use Freescale products. There are no express or implied copyright licenses granted hereunder to design or fabricate any integrated circuits based on the information in this document.

Freescale reserves the right to make changes without further notice to any products herein. Freescale makes no warranty, representation, or guarantee regarding the suitability of its products for any particular purpose, nor does Freescale assume any liability arising out of the application or use of any product or circuit, and specifically disclaims any and all liability, including without limitation consequential or incidental damages. "Typical" parameters that may be provided in Freescale data sheets and/or specifications can and do vary in different applications, and actual performance may vary over time. All operating parameters, including "typicals," must be validated for each customer application by customer's technical experts. Freescale does not convey any license under its patent rights nor the rights of others. Freescale sells products pursuant to standard terms and conditions of sale, which can be found at the following address: freescale.com/salestermsandconditions.

Freescale and the Freescale logo are trademarks of Freescale Semiconductor, Inc., Reg. U.S. Pat. & Tm. Off. All other product or service names are the property of their respective owners.

© 2015 Freescale Semiconductor, Inc.

Looking for pricing, stock, or lifecycle information?

Click below to explore more details on WIN SOURCE:

- ⊖ [View MPXA6115AC6U on WIN SOURCE](#)
- ⊖ [Freescale Semiconductor - NXP Information](#)

Optimize Your Supply Chain with WIN SOURCE Solutions

- ✓ Global Sourcing Solution
- ✓ Obsolete Management
- ✓ Cost Control Management
- ✓ Shortage Management
- ✓ Alternative Solution
- ✓ Excess Inventory Management