



THE DATASHEET OF MPXM2053GS



MPX2053

50 kPa Temperature Compensated Pressure Sensors

Rev. 11 — 22 April 2021

Product data sheet

1 General Description

The MPX2053 series devices are silicon piezoresistive pressure sensors that provide a highly accurate and linear voltage output directly proportional to the applied pressure. The sensor is a single monolithic silicon diaphragm with the strain gauge and a thin-film resistor network integrated on-chip. The chip is laser trimmed for precise span and offset calibration and temperature compensation.

2 Features and Benefits

- Ratiometric to Supply Voltage
- Differential and Gauge Options
- Temperature Compensated over 0 °C to 85 °C
- Easy-to-Use Chip Carrier Package Options

3 Applications

- Level Indicators
- Medical Diagnostics
- Robotics
- Pressure Switching
- Pump/Motor Controllers
- Non-Invasive Blood Pressure Measurement



4 Ordering Information

Table 1. Ordering information

Device Name	Package options	Case number	Number of ports			Pressure type			Device marking
			None	Single	Dual	Gauge	Differential	Absolute	
Small Outline Package (MPXV2053 series)									
MPXV2053DP	Tray	1351			•		•		MPXV2053DP
Unibody Package (MPX2053 Series)									
MPX2053D	Tray	344	•				•		MPX2053D
MPAK Package (MPXM2053 Series)									
MPXM2053DT1	Tape & Reel	1320	•				•		MPXM2053D
MPXM2053GS	Tube	1320A		•		•			MPXM2053GS
MPXM2053GST1	Tape & Reel	1320A		•		•			MPXM2053GS

Unibody Package



MPX2053D
Case 344-15

Small Outline Package



MPXV2053DP
Case 1351-01

MPAK Packages



MPXM2053DT1
Case 1320-02



MPXM2053GS/GST1
Case 1320A-02

5 Block Diagram

Figure 1 shows a block diagram of the internal circuitry on the stand-alone pressure sensor chip.

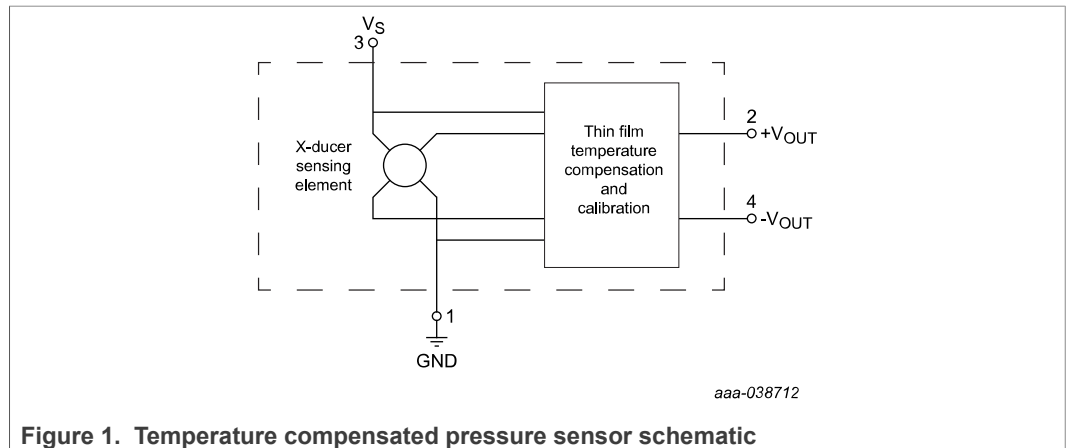

6 Pin Information

6.1 MPX2053D

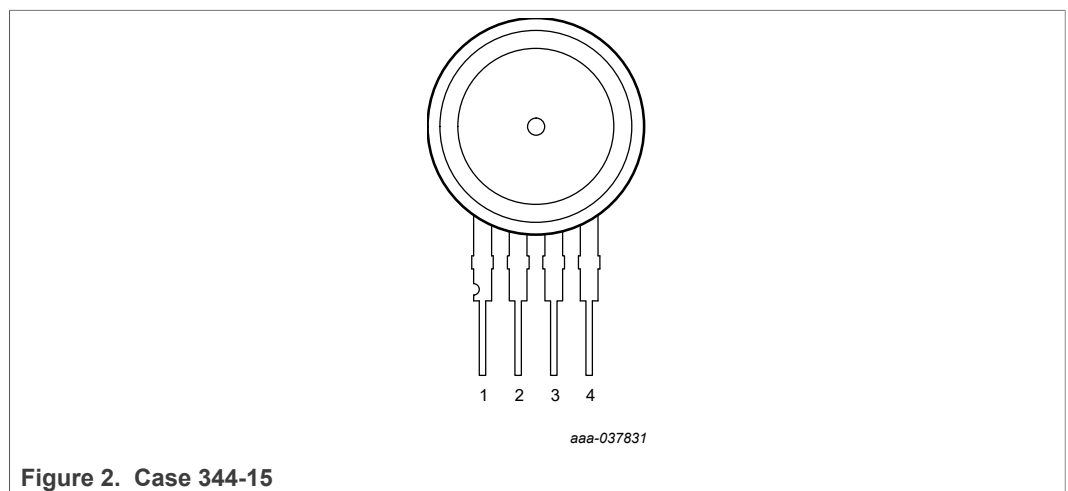

Table 2. Pin definitions – MPX2053D

Symbol	Pin	Description
GND	1	Ground
+V _{OUT}	2	+ Voltage output
V _S	3	Power supply
-V _{OUT}	4	- Voltage output

6.2 MPXM2053GS/GST1

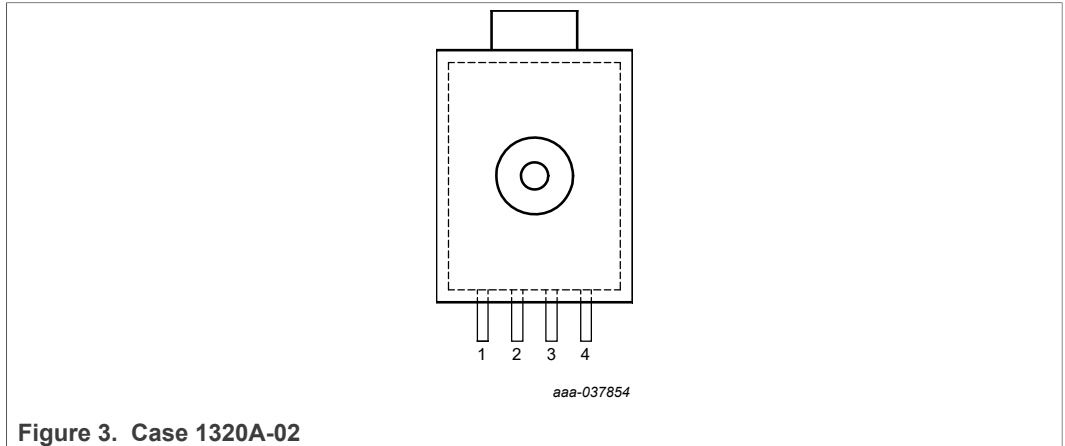

Figure 3. Case 1320A-02

Table 3. Pin definitions – MPXM2053GS/GST1

Symbol	Pin	Description
GND	1	Ground
+V _{OUT}	2	+ Voltage output
V _S	3	Power supply
-V _{OUT}	4	- Voltage output

6.3 MPXV2053DP

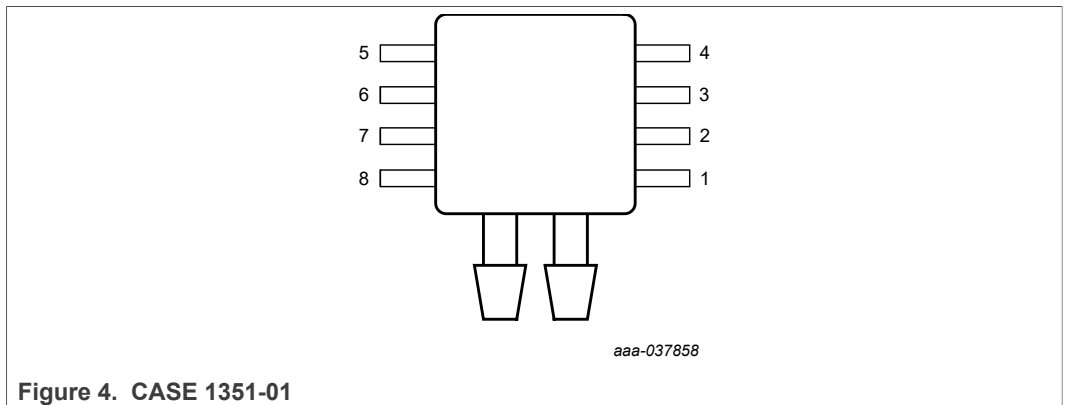

Figure 4. CASE 1351-01

Table 4. Pin definitions – MPXV2053DP

Symbol	Pin	Description
GND	1	Ground
+V _{OUT}	2	+ Voltage output
V _S	3	Power supply
-V _{OUT}	4	- Voltage output
n.a.	5	—
n.a.	6	—
n.a.	7	—
n.a.	8	—

6.4 MPXM2053DT1

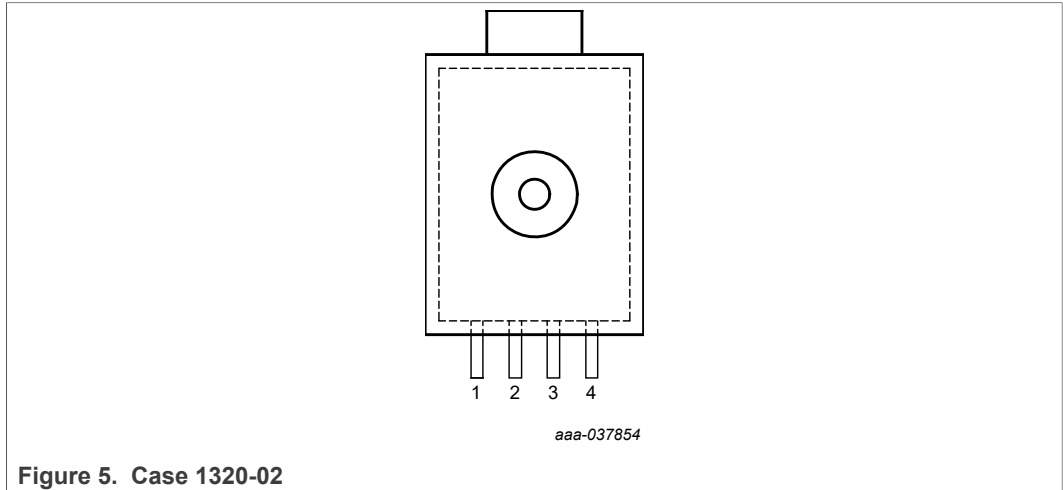

Figure 5. Case 1320-02

Table 5. Pin definitions - MPXM2053DT1

Symbol	Pin	Description
GND	1	Ground
+V _{OUT}	2	+ Voltage output
V _S	3	Power supply
-V _{OUT}	4	- Voltage output

7 Maximum Ratings

Table 6. Maximum ratings

Exposure beyond the specified limits may cause permanent damage or degradation to the device.

In accordance with the Absolute Maximum Rating System (IEC 60134).

Symbol	Parameter	Conditions	Min	Typ	Max	Unit
P _{max}	Overpressure	P1 > P2	—	—	200	kPa
T _{stg}	Storage Temperature		-40	—	+125	°C
T _A	Operating Temperature		-40	—	+125	°C

8 Operating Characteristics

Table 7. Operating Characteristics ($V_S = 10.0$ Vdc, $T_A = 25$ °C unless otherwise noted, $P_1 > P_2$)

Characteristic	Symbol	Min	Typ	Max	Unit
Operating Pressure Range [1]	P_{OP}	0	—	50	kPa
Supply Voltage [2]	V_S	—	10	16	Vdc
Supply Current	I_o	—	6.0	—	mAdc
Full Scale Span [3]	V_{FSS}	38.5	40	41.5	mV
Offset [4]	V_{off}	-1.0	—	1.0	mV
Sensitivity	$\Delta V/\Delta P$	—	0.8	—	mV/kPa
Linearity [5]	—	-0.6	—	0.4	% V_{FSS}
Pressure Hysteresis (0 kPa to 50 kPa) [5]	—	—	± 0.1	—	% V_{FSS}
Temperature Hysteresis (-40 °C to 125 °C) [5]	—	—	± 0.5	—	% V_{FSS}
Temperature Coefficient of Full Scale Span [5]	TCV_{FSS}	-2.0	—	2.0	% V_{FSS}
Temperature Coefficient of Offset [5]	TCV_{off}	-1.0	—	1.0	mV
Input Impedance	Z_{in}	1000	—	2500	Ω
Output Impedance	Z_{out}	1400	—	3000	Ω
Response Time (10% to 90%) [6]	t_R	—	1.0	—	ms
Warm-Up Time [7]	—	—	20	—	ms
Offset Stability [8]	—	—	± 0.5	—	% V_{FSS}

[1] 1.0 kPa equals 0.145 PSI.

[2] Device is ratiometric within this specified excitation range. Operating the device above the specified excitation range may induce additional error due to device self-heating.

[3] Full Scale Span (V_{FSS}) is defined as the algebraic difference between the output voltage at full rated pressure and the output voltage at the minimum rated pressure.

[4] Offset (V_{off}) is defined as the output voltage at the minimum rated pressure.

[5] Accuracy (error budget) consists of the following:

- Linearity: Output deviation from a straight line relationship with pressure, using the end point method, over the specified pressure range.
- Temperature Hysteresis: Output deviation at any temperature within the operating temperature range, after the temperature is cycled to and from the minimum or maximum operating temperature points, with zero differential pressure applied.
- Pressure Hysteresis: Output deviation at any pressure within the specified range, when this pressure is cycled to and from the minimum or maximum rated pressure, at 25 °C.
- TcSpan: Output deviation at full rated pressure over the temperature range of 0 °C to 85 °C, relative to 25 °C
- TcOffset: Output deviation with minimum rated pressure applied, over the temperature range of 0 °C to 85 °C, relative to 25 °C

[6] Response Time is defined as the time for the incremental change in the output to go from 10% to 90% of its final value when subjected to a specified step change in pressure.

[7] Warm-Up Time is defined as the time required for the product to meet the specified output voltage after the pressure has been stabilized.

[8] Offset Stability is the product's output deviation when subjected to 1000 hours of Pulsed Pressure Temperature Cycling with Bias test.

9 Characteristics

9.1 Voltage output versus applied differential pressure

The output voltage of the differential or gauge sensor increases with increasing pressure applied to the pressure side (P1) relative to the vacuum side (P2). Similarly, output voltage increases as increasing vacuum is applied to the vacuum side (P2) relative to the pressure side (P1).

9.2 On-chip temperature compensation and calibration

Figure 6 shows the typical output characteristics of the MPX2053 series at 25 °C.

The effects of temperature on full scale span and offset are very small and are shown under Section 8 "Operating Characteristics".

This performance over temperature is achieved by having both the shear stress strain gauge and the thin-film resistor circuitry on the same silicon diaphragm. Each chip is dynamically laser trimmed for precise span and offset calibration and temperature compensation.

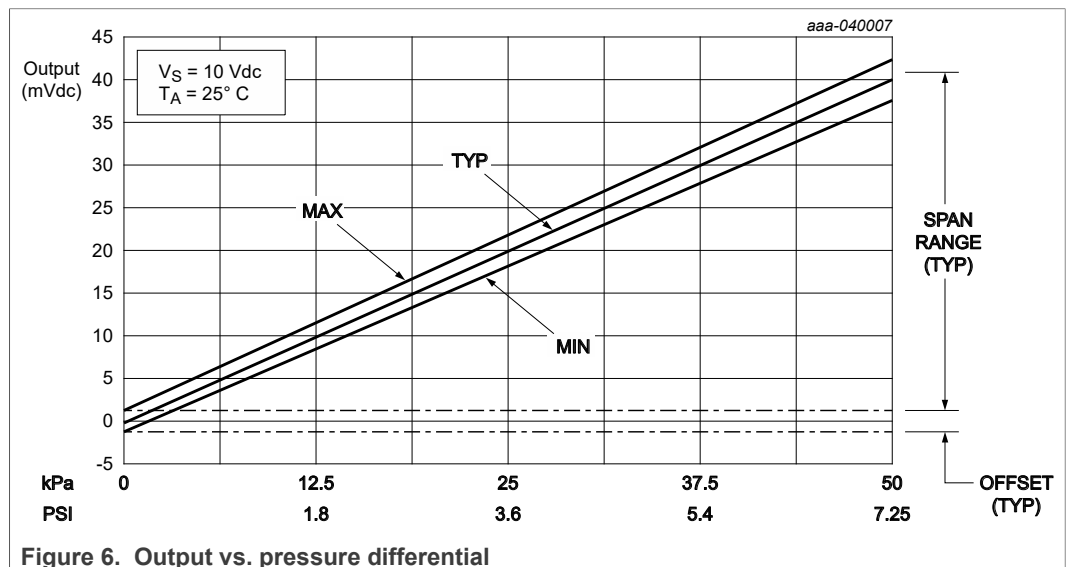

9.3 Linearity

Linearity refers to how well a transducer's output follows the equation $V_{out} = V_{off} + \text{Sensitivity} \times P$ over the operating pressure range (Figure 7). There are two basic methods for calculating nonlinearity:

- End point straight line fit
- Least squares best line fit

While a least squares fit gives the "best case" linearity error (lower numerical value), the calculations required are burdensome.

Conversely, an end point fit will give the "worst case" error (often more desirable in error budget calculations) and the calculations are more straightforward for the user.

NXP's specified pressure sensor linearities are based on the end point straight line method measured at the midrange pressure.

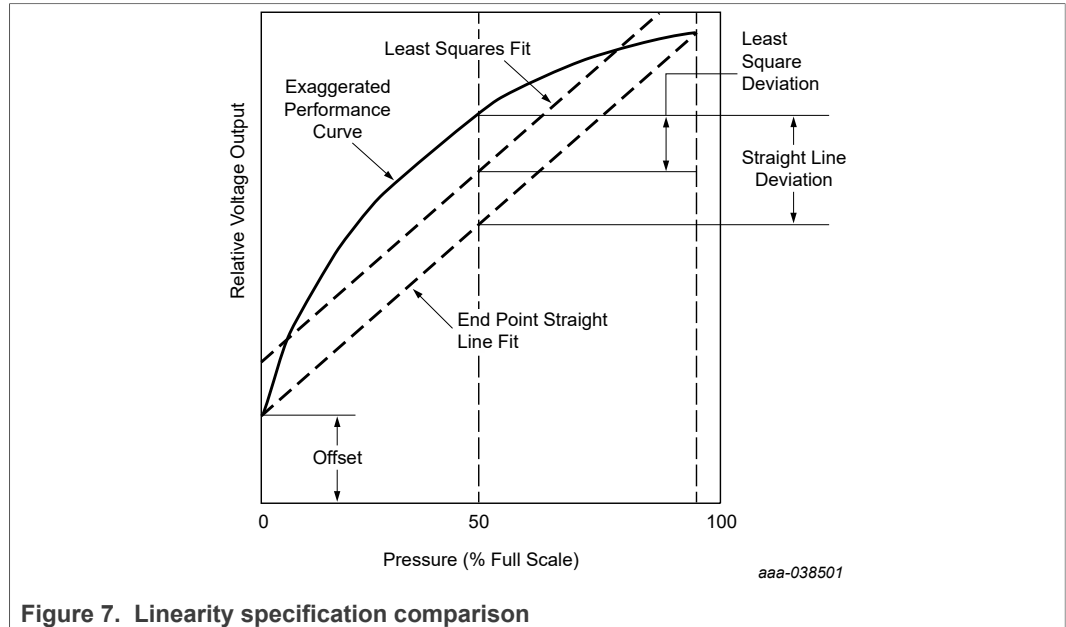

9.4 Pressure (P1) / Vacuum (P2) side identification

NXP designates the two sides of the pressure sensor as the Pressure (P1) side and the Vacuum (P2) side. The Pressure (P1) side is the side containing silicone gel that isolates the die from the environment. The NXP MPX pressure sensor is designed to operate with positive differential pressure applied, $P1 > P2$.

The Pressure (P1) side may be identified by using [Table 8](#).

Table 8. Pressure (P1) side delineation table

Part Number	Case Type	Pressure (P1) Side Identifier
MPX2053D	344	Stainless Steel Cap
MPXV2053DP	1351	Side with Part Marking
MPXM2053DT1	1320	Side with Part Marking
MPXM2053GS/GST1	1320A	Side with Port Attached

9.5 Media compatibility

[Figure 8](#) illustrates the differential or gauge configuration in a typical chip carrier. A silicone gel isolates the die surface and wire bonds from the environment while allowing the pressure signal to be transmitted to the silicon diaphragm.

The MPX2053 series pressure sensor operating characteristics, internal reliability and qualification tests are based on the use of dry clean air as the pressure medium. Media other than dry clean air may have adverse effects on sensor performance and long term reliability. Contact the factory for information regarding media compatibility in your application.

For more information, refer to application note [AN3728](#).

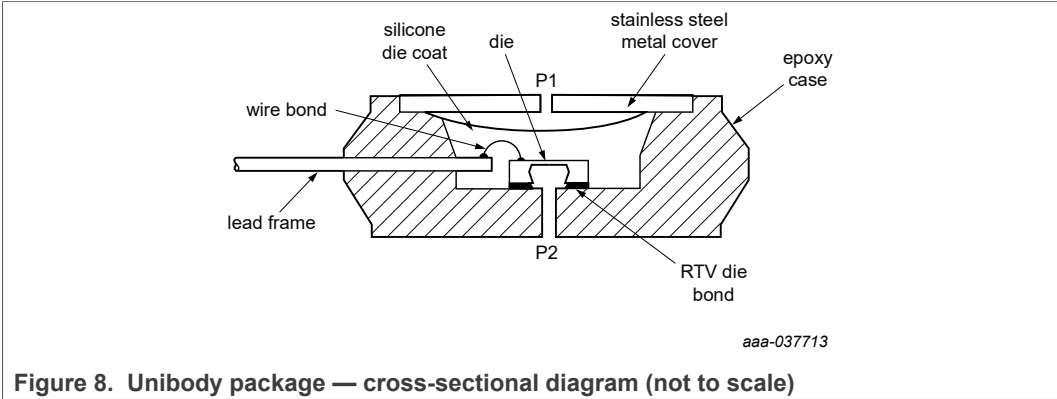

10 Package Outlines

Package dimensions are provided in package drawings. To find the most current package outline drawing, go to <https://www.nxp.com/> and perform a keyword search for the drawing's document number.

10.1 Small outline packages

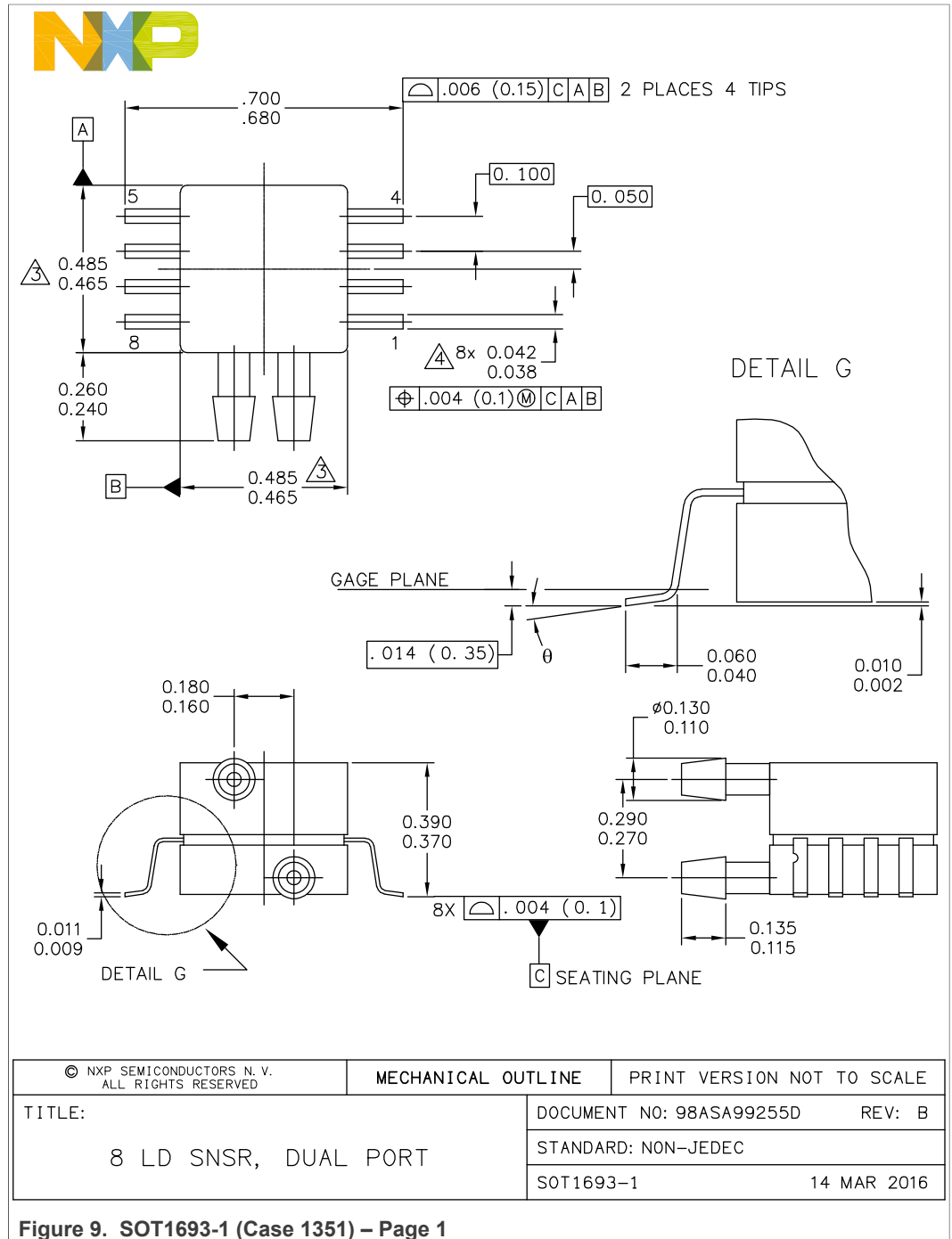

Figure 9. SOT1693-1 (Case 1351) – Page 1



NOTES:

1. CONTROLLING DIMENSION: INCH
2. INTERPRET DIMENSIONS AND TOLERANCES PER ASME Y14.5M-1994.
3. DIMENSIONS DO NOT INCLUDE MOLD FLASH OR PROTRUSIONS. MOLD FLASH AND PROTRUSIONS SHALL NOT EXCEED .006 PER SIDE.
4. DIMENSION DOES NOT INCLUDE DAMBAR PROTRUSION. ALLOWABLE DAMBAR PROTRUSION SHALL BE .008 MAXIMUM.

STYLE 1:

PIN 1: GND
 PIN 2: +Vout
 PIN 3: Vs
 PIN 4: -Vout
 PIN 5: N/C
 PIN 6: N/C
 PIN 7: N/C
 PIN 8: N/C

STYLE 2:

PIN 1: N/C
 PIN 2: Vs
 PIN 3: GND
 PIN 4: Vout
 PIN 5: N/C
 PIN 6: N/C
 PIN 7: N/C
 PIN 8: N/C

© NXP SEMICONDUCTORS N. V. ALL RIGHTS RESERVED	MECHANICAL OUTLINE	PRINT VERSION NOT TO SCALE
TITLE: 8 LD SNSR, DUAL PORT	DOCUMENT NO: 98ASA99255D	REV: B
	STANDARD: NON-JEDEC	
	SOT1693-1	14 MAR 2016

Figure 10. SOT1693-1 (Case 1351) – Page 2

10.2 Unibody packages

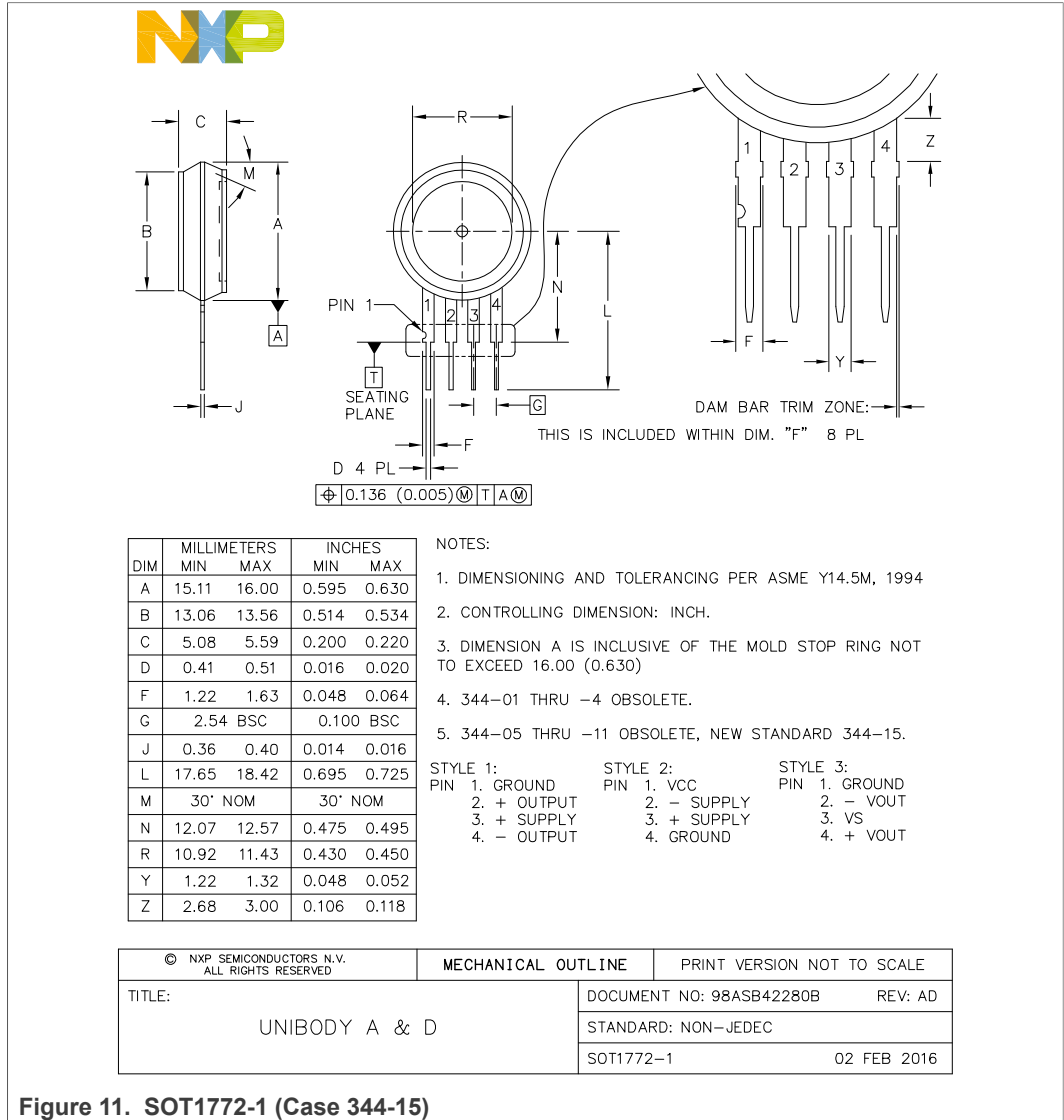

Figure 11. SOT1772-1 (Case 344-15)



NOTES:

- 1. DIMENSIONS ARE IN INCHES.
- 2. INTERPRET DIMENSIONS AND TOLERANCES PER ASME Y14.5M-1994.
- 3. DIMENSIONS DOES NOT INCLUDE MOLD FLASH OR PROTRUSION. MOLD FLASH OR PROTRUSION SHALL NOT EXCEED .006" PER SIDE.
- 4. ALL VERTICAL SURFACES TO BE 5" MAXIMUM.
- 5. DIMENSION DOES NOT INCLUDE DAMBAR PROTRUSION. ALLOWABLE DAMBAR PROTRUSION SHALL BE .008 MAXIMUM.

© NXP SEMICONDUCTORS N.V. ALL RIGHTS RESERVED	MECHANICAL OUTLINE	PRINT VERSION NOT TO SCALE
TITLE: 5 LD M-PAC, PORTED	DOCUMENT NO: 98ARH99087A	REV: B
	STANDARD: NON-JEDEC	
	SOT1673-1	29 FEB 2016

Figure 13. SOT1673-1 (1320A-02) – Page 2

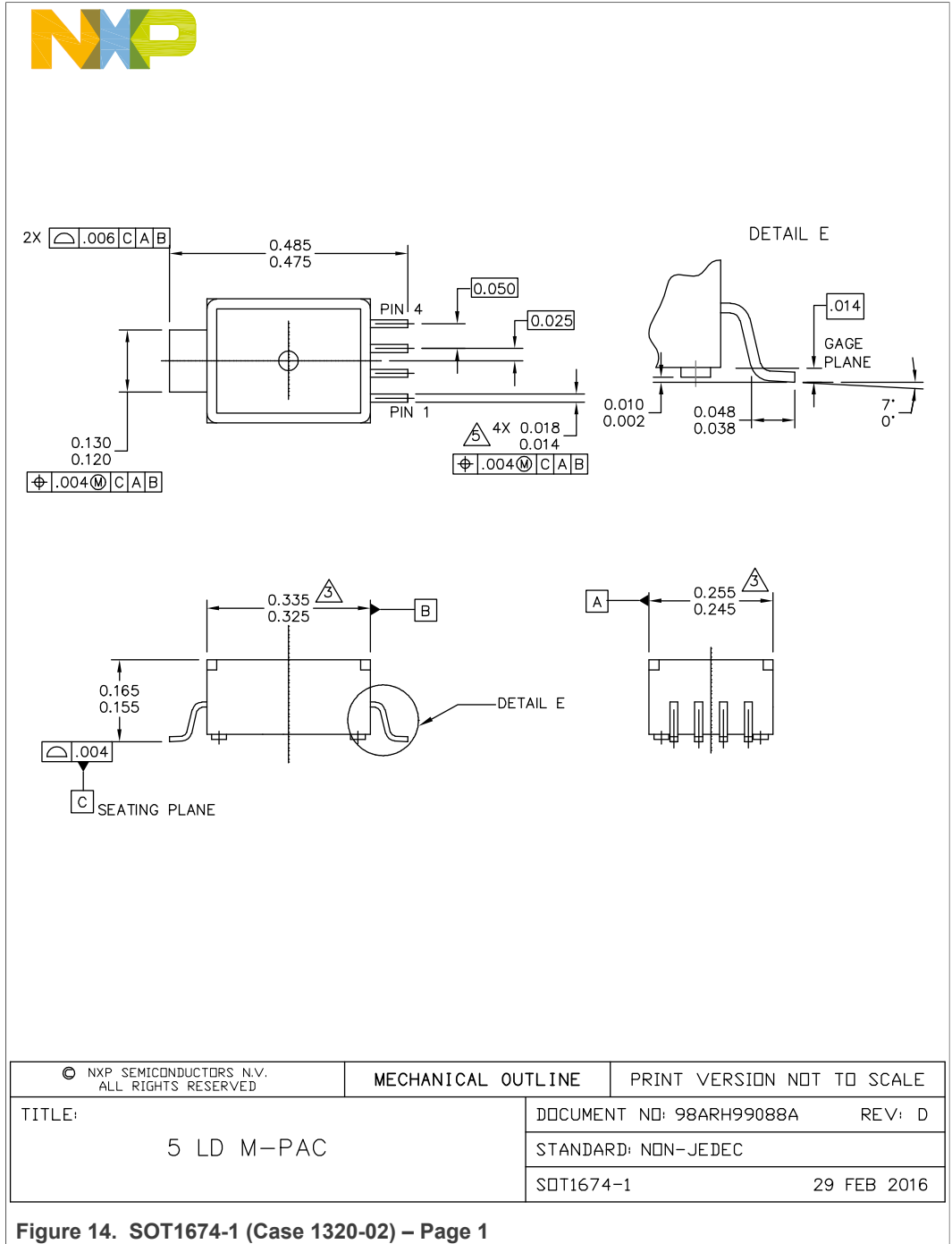



NOTES:

- 1. DIMENSIONS ARE IN INCHES.
- 2. INTERPRET DIMENSIONS AND TOLERANCES PER ASME Y14.5M-1994.
- 3. DIMENSION DOES NOT INCLUDE MOLD FLASH OR PROTRUSION. MOLD FLASH OR PROTRUSION SHALL NOT EXCEED .006" PER SIDE.
- 4. ALL VERTICAL SURFACES TO BE 5° MAXIMUM.
- 5. DIMENSION DOES NOT INCLUDE DAMBAR PROTRUSION. ALLOWABLE DAMBAR PROTRUSION SHALL BE .008 MAXIMUM.

PIN 1: GND
 PIN 2: +Vout
 PIN 3: Vs
 PIN 4: -Vout

© NXP SEMICONDUCTORS N. V. ALL RIGHTS RESERVED	MECHANICAL OUTLINE	PRINT VERSION NOT TO SCALE
TITLE: 5 LD M-PAC	DOCUMENT NO: 98ARH99088A	REV: D
	STANDARD: NON-JEDEC	
	SOT1674-1	29 FEB 2016

Figure 15. SOT1674-1 (Case 1320-02) – page 2

11 References

- [1] AN840 – Temperature Compensation Methods For The Motorola X-ducer Pressure Sensor Element
<https://www.nxp.com/docs/en/application-note/AN840.pdf>
- [2] AN1984 – Handling Freescale Pressure Sensors
<https://www.nxp.com/docs/en/application-note/AN1984.pdf>
- [3] AN3150 – Soldering Recommendations for Pressure Sensor Devices
<https://www.nxp.com/docs/en/application-note/AN3150.pdf>
- [4] AN1318 Interfacing Semiconductor Pressure Sensors to Microcomputers
<https://www.nxp.com/docs/en/application-note/AN1318.pdf>
- [5] AN3728 Media Compatibility for IPS PRT Pressure Sensors
<https://www.nxp.com/docs/en/application-note/AN3728.pdf>

12 Revision history

Table 9. Revision history

Document ID	Release date	Data sheet status	Change notice	Supersedes
MPX2053 v.11	20210422	Product data sheet	-	MPX2053 v.10
Modifications	<ul style="list-style-type: none"> Redesigned the data sheet to comply with the new identity guidelines of NXP Semiconductors. Adapted legal texts to the new company name where appropriate. 			
MPX2053 v.10	200907	Product data sheet	-	MPX2053 v.10
Modifications	<ul style="list-style-type: none"> This data sheet has been formatted to comply with the identity guidelines of NXP Semiconductors. Ordering Information: Removed MPX2053DP, MPX2053GP and MPXV2053GP from the table. Package images: Removed the package images for MPX2053DP, MPX2053GP and MPXV2053GP. Updated all other package images. Section 8: Revised “Non-Linearity” to “Linearity” and added new footnote after Linearity, Pressure Hysteresis, Temperature Hysteresis, Temperature Coefficient of Full Scale, and Temperature Coefficient of Offset. Package Dimensions: Removed package dimensions for Case 344B-01 Issue B, Unibody package, Case 344C-01 Issue B, Unibody package, and Case 1369-01, Issue D Small Outline package. Updated all other package dimension images. 			
MPX2053 v.0	200907	Product data sheet	-	MPX2053 v.8
Modifications	<ul style="list-style-type: none"> Deleted references to device number MPXV2053GVP throughout the document 			

13 Legal information

13.1 Data sheet status

Document status ^{[1][2]}	Product status ^[3]	Definition
Objective [short] data sheet	Development	This document contains data from the objective specification for product development.
Preliminary [short] data sheet	Qualification	This document contains data from the preliminary specification.
Product [short] data sheet	Production	This document contains the product specification.

[1] Please consult the most recently issued document before initiating or completing a design.

[2] The term 'short data sheet' is explained in section "Definitions".

[3] The product status of device(s) described in this document may have changed since this document was published and may differ in case of multiple devices. The latest product status information is available on the Internet at URL <http://www.nxp.com>.

13.2 Definitions

Draft — A draft status on a document indicates that the content is still under internal review and subject to formal approval, which may result in modifications or additions. NXP Semiconductors does not give any representations or warranties as to the accuracy or completeness of information included in a draft version of a document and shall have no liability for the consequences of use of such information.

Short data sheet — A short data sheet is an extract from a full data sheet with the same product type number(s) and title. A short data sheet is intended for quick reference only and should not be relied upon to contain detailed and full information. For detailed and full information see the relevant full data sheet, which is available on request via the local NXP Semiconductors sales office. In case of any inconsistency or conflict with the short data sheet, the full data sheet shall prevail.

Product specification — The information and data provided in a Product data sheet shall define the specification of the product as agreed between NXP Semiconductors and its customer, unless NXP Semiconductors and customer have explicitly agreed otherwise in writing. In no event however, shall an agreement be valid in which the NXP Semiconductors product is deemed to offer functions and qualities beyond those described in the Product data sheet.

13.3 Disclaimers

Limited warranty and liability — Information in this document is believed to be accurate and reliable. However, NXP Semiconductors does not give any representations or warranties, expressed or implied, as to the accuracy or completeness of such information and shall have no liability for the consequences of use of such information. NXP Semiconductors takes no responsibility for the content in this document if provided by an information source outside of NXP Semiconductors. In no event shall NXP Semiconductors be liable for any indirect, incidental, punitive, special or consequential damages (including - without limitation - lost profits, lost savings, business interruption, costs related to the removal or replacement of any products or rework charges) whether or not such damages are based on tort (including negligence), warranty, breach of contract or any other legal theory. Notwithstanding any damages that customer might incur for any reason whatsoever, NXP Semiconductors' aggregate and cumulative liability towards customer for the products described herein shall be limited in accordance with the Terms and conditions of commercial sale of NXP Semiconductors.

Right to make changes — NXP Semiconductors reserves the right to make changes to information published in this document, including without limitation specifications and product descriptions, at any time and without

notice. This document supersedes and replaces all information supplied prior to the publication hereof.

Suitability for use — NXP Semiconductors products are not designed, authorized or warranted to be suitable for use in life support, life-critical or safety-critical systems or equipment, nor in applications where failure or malfunction of an NXP Semiconductors product can reasonably be expected to result in personal injury, death or severe property or environmental damage. NXP Semiconductors and its suppliers accept no liability for inclusion and/or use of NXP Semiconductors products in such equipment or applications and therefore such inclusion and/or use is at the customer's own risk.

Applications — Applications that are described herein for any of these products are for illustrative purposes only. NXP Semiconductors makes no representation or warranty that such applications will be suitable for the specified use without further testing or modification. Customers are responsible for the design and operation of their applications and products using NXP Semiconductors products, and NXP Semiconductors accepts no liability for any assistance with applications or customer product design. It is customer's sole responsibility to determine whether the NXP Semiconductors product is suitable and fit for the customer's applications and products planned, as well as for the planned application and use of customer's third party customer(s). Customers should provide appropriate design and operating safeguards to minimize the risks associated with their applications and products. NXP Semiconductors does not accept any liability related to any default, damage, costs or problem which is based on any weakness or default in the customer's applications or products, or the application or use by customer's third party customer(s). Customer is responsible for doing all necessary testing for the customer's applications and products using NXP Semiconductors products in order to avoid a default of the applications and the products or of the application or use by customer's third party customer(s). NXP does not accept any liability in this respect.

Limiting values — Stress above one or more limiting values (as defined in the Absolute Maximum Ratings System of IEC 60134) will cause permanent damage to the device. Limiting values are stress ratings only and (proper) operation of the device at these or any other conditions above those given in the Recommended operating conditions section (if present) or the Characteristics sections of this document is not warranted. Constant or repeated exposure to limiting values will permanently and irreversibly affect the quality and reliability of the device.

Terms and conditions of commercial sale — NXP Semiconductors products are sold subject to the general terms and conditions of commercial sale, as published at <http://www.nxp.com/profile/terms>, unless otherwise agreed in a valid written individual agreement. In case an individual agreement is concluded only the terms and conditions of the respective agreement shall apply. NXP Semiconductors hereby expressly objects to applying the customer's general terms and conditions with regard to the purchase of NXP Semiconductors products by customer.

No offer to sell or license — Nothing in this document may be interpreted or construed as an offer to sell products that is open for acceptance or the grant, conveyance or implication of any license under any copyrights, patents or other industrial or intellectual property rights.

Quick reference data — The Quick reference data is an extract of the product data given in the Limiting values and Characteristics sections of this document, and as such is not complete, exhaustive or legally binding.

Export control — This document as well as the item(s) described herein may be subject to export control regulations. Export might require a prior authorization from competent authorities.

Translations — A non-English (translated) version of a document is for reference only. The English version shall prevail in case of any discrepancy between the translated and English versions.

Security — Customer understands that all NXP products may be subject to unidentified or documented vulnerabilities. Customer is responsible for the design and operation of its applications and products throughout their lifecycles to reduce the effect of these vulnerabilities on customer's

applications and products. Customer's responsibility also extends to other open and/or proprietary technologies supported by NXP products for use in customer's applications. NXP accepts no liability for any vulnerability. Customer should regularly check security updates from NXP and follow up appropriately. Customer shall select products with security features that best meet rules, regulations, and standards of the intended application and make the ultimate design decisions regarding its products and is solely responsible for compliance with all legal, regulatory, and security related requirements concerning its products, regardless of any information or support that may be provided by NXP. NXP has a Product Security Incident Response Team (PSIRT) (reachable at PSIRT@nxp.com) that manages the investigation, reporting, and solution release to security vulnerabilities of NXP products.

13.4 Trademarks

Notice: All referenced brands, product names, service names and trademarks are the property of their respective owners.

NXP — wordmark and logo are trademarks of NXP B.V.

Tables

Tab. 1.	Ordering information	2	Tab. 7.	Operating Characteristics (VS = 10.0 Vdc, TA = 25 °C unless otherwise noted, P1 > P2)	7
Tab. 2.	Pin definitions – MPX2053D	3	Tab. 8.	Pressure (P1) side delineation table	9
Tab. 3.	Pin definitions – MPXM2053GS/GST1	4	Tab. 9.	Revision history	18
Tab. 4.	Pin definitions – MPXV2053DP	4			
Tab. 5.	Pin definitions - MPXM2053DT1	5			
Tab. 6.	Maximum ratings	6			

Figures

Fig. 1.	Temperature compensated pressure sensor schematic	3	Fig. 8.	Unibody package — cross-sectional diagram (not to scale)	10
Fig. 2.	Case 344-15	3	Fig. 9.	SOT1693-1 (Case 1351) – Page 1	11
Fig. 3.	Case 1320A-02	4	Fig. 10.	SOT1693-1 (Case 1351) – Page 2	12
Fig. 4.	CASE 1351-01	4	Fig. 11.	SOT1772-1 (Case 344-15)	13
Fig. 5.	Case 1320-02	5	Fig. 12.	SOT1673-1 (1320A-02) – Page 1	14
Fig. 6.	Output vs. pressure differential	8	Fig. 13.	SOT1673-1 (1320A-02) – Page 2	15
Fig. 7.	Linearity specification comparison	9	Fig. 14.	SOT1674-1 (Case 1320-02) – Page 1	16
			Fig. 15.	SOT1674-1 (Case 1320-02) – page 2	17

Contents

1	General Description	1
2	Features and Benefits	1
3	Applications	1
4	Ordering Information	2
5	Block Diagram	3
6	Pin Information	3
6.1	MPX2053D	3
6.2	MPXM2053GS/GST1	4
6.3	MPXV2053DP	4
6.4	MPXM2053DT1	5
7	Maximum Ratings	6
8	Operating Characteristics	7
9	Characteristics	8
9.1	Voltage output versus applied differential pressure	8
9.2	On-chip temperature compensation and calibration	8
9.3	Linearity	8
9.4	Pressure (P1) / Vacuum (P2) side identification	9
9.5	Media compatibility	9
10	Package Outlines	11
10.1	Small outline packages	11
10.2	Unibody packages	13
10.3	MPAK packages	14
11	References	18
12	Revision history	18
13	Legal information	19

Please be aware that important notices concerning this document and the product(s) described herein, have been included in section 'Legal information'.

© NXP B.V. 2021.

All rights reserved.

For more information, please visit: <http://www.nxp.com>

For sales office addresses, please send an email to: salesaddresses@nxp.com

Date of release: 22 April 2021
Document identifier: MPX2053

Looking for pricing, stock, or lifecycle information?

Click below to explore more details on WIN SOURCE:

- ⊖ [View MPXM2053GS on WIN SOURCE](#)
- ⊖ [Freescale Semiconductor - NXP Information](#)

Optimize Your Supply Chain with WIN SOURCE Solutions

- ✓ Global Sourcing Solution
- ✓ Obsolete Management
- ✓ Cost Control Management
- ✓ Shortage Management
- ✓ Alternative Solution
- ✓ Excess Inventory Management