



## The RF Line NPN Silicon Power Transistor 250W, 30MHz, 50V

Rev. V1

Designed primarily for high-voltage applications as a high-power linear amplifiers from 2.0 to 30 MHz. Ideal for marine and base station equipment.

- Specified 50 V, 30 MHz characteristics
  - Output power = 250 W
  - Minimum gain = 12 dB
  - Efficiency = 45%
- Intermodulation distortion @ 250 W (PEP) —
  - IMD = -30 dB (max)
- 100% tested for load mismatch at all phase angles with 3:1 VSWR

### Product Image

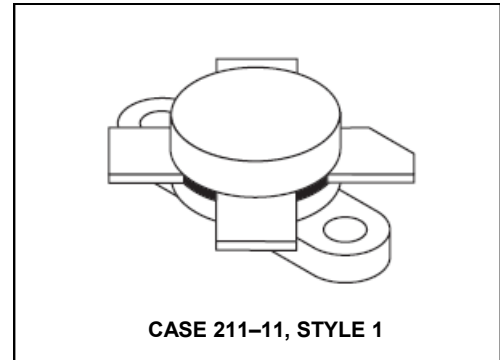

### MAXIMUM RATINGS

Rating	Symbol	Value	Unit
Collector-Emitter Voltage	$V_{CEO}$	50	Vdc
Collector-Base Voltage	$V_{CBO}$	100	Vdc
Emitter-Base Voltage	$V_{EBO}$	4.0	Vdc
Collector Current — Continuous	$I_C$	16	Adc
Withstand Current — 10 s	—	20	Adc
Total Device Dissipation @ $T_C = 25^\circ\text{C}$ (1) Derate above $25^\circ\text{C}$	$P_D$	290 1.67	Watts W/ $^\circ\text{C}$
Storage Temperature Range	$T_{stg}$	-65 to +150	$^\circ\text{C}$

### THERMAL CHARACTERISTICS

Characteristic	Symbol	Max	Unit
Thermal Resistance, Junction to Case	$R_{\theta JC}$	0.6	$^\circ\text{C/W}$

### ELECTRICAL CHARACTERISTICS ( $T_C = 25^\circ\text{C}$ unless otherwise noted.)

Characteristic	Symbol	Min	Typ	Max	Unit
----------------	--------	-----	-----	-----	------

### OFF CHARACTERISTICS

Collector-Emitter Breakdown Voltage ( $I_C = 200 \text{ mAdc}$ , $I_B = 0$ )	$V_{(BR)CEO}$	50	—	—	Vdc
Collector-Emitter Breakdown Voltage ( $I_C = 100 \text{ mAdc}$ , $V_{BE} = 0$ )	$V_{(BR)CES}$	100	—	—	Vdc
Collector-Base Breakdown Voltage ( $I_C = 100 \text{ mAdc}$ , $I_E = 0$ )	$V_{(BR)CBO}$	100	—	—	Vdc
Emitter-Base Breakdown Voltage ( $I_E = 10 \text{ mAdc}$ , $I_C = 0$ )	$V_{(BR)EBO}$	4.0	—	—	Vdc

NOTE:

- $P_D$  is a measurement reflecting short term maximum condition. See SOAR curve for operating conditions.

(continued)

## The RF Line NPN Silicon Power Transistor 250W, 30MHz, 50V

Rev. V1

### ELECTRICAL CHARACTERISTICS — continued ( $T_C = 25^\circ\text{C}$ unless otherwise noted.)

Characteristic	Symbol	Min	Typ	Max	Unit
----------------	--------	-----	-----	-----	------

#### ON CHARACTERISTICS

DC Current Gain ( $I_C = 5.0 \text{ Adc}$ , $V_{CE} = 10 \text{ Vdc}$ )	$h_{FE}$	10	30	—	—
--	----------	----	----	---	---

#### DYNAMIC CHARACTERISTICS

Output Capacitance ( $V_{CB} = 50 \text{ Vdc}$ , $I_E = 0$ , $f = 1.0 \text{ MHz}$ )	$C_{ob}$	—	350	450	pF
---	----------	---	-----	-----	----

#### FUNCTIONAL TESTS

Common-Emitter Amplifier Power Gain ( $V_{CC} = 50 \text{ Vdc}$ , $P_{out} = 250 \text{ W CW}$ , $f = 30 \text{ MHz}$ , $I_{CQ} = 250 \text{ mA}$ )	$G_{pE}$	12	14	—	dB
Collector Efficiency ( $V_{CC} = 50 \text{ Vdc}$ , $P_{out} = 250 \text{ W}$ , $f = 30 \text{ MHz}$ , $I_{CQ} = 250 \text{ mA}$ )	$\eta$	—	45 65	—	% (PEP) % (CW)
Intermodulation Distortion (2) ( $V_{CE} = 50 \text{ Vdc}$ , $P_{out} = 250 \text{ W (PEP)}$ , $I_{CQ} = 250 \text{ mA}$ , $f = 30 \text{ MHz}$ )	IMD	—	-33	-30	dB
Electrical Ruggedness ( $V_{CC} = 50 \text{ Vdc}$ , $P_{out} = 250 \text{ W CW}$ , $f = 30 \text{ MHz}$ , VSWR 3:1 at all Phase Angles)	$\psi$	No Degradation in Output Power			

#### NOTE:

- To Mil-Std-1311 Version A, Test Method 2204, Two Tone, Reference each Tone.

## The RF Line NPN Silicon Power Transistor 250W, 30MHz, 50V

Rev. V1

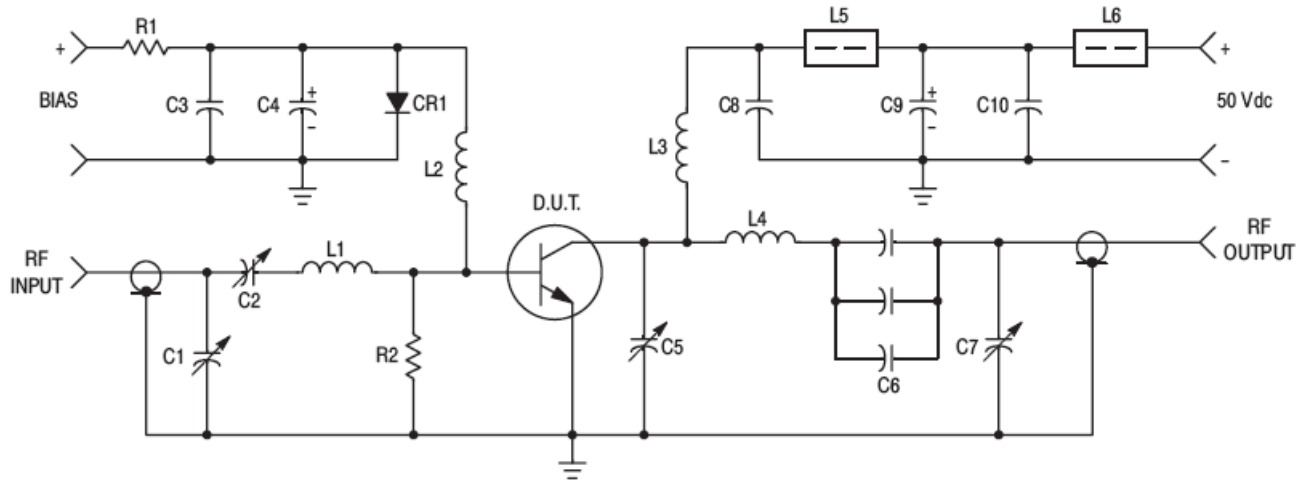

C1, C2, C5, C7 — 170–780 pF, Arco 469  
 C3, C8, C9 — 0.1  $\mu$ F, 100 V Erie  
 C4 — 500  $\mu$ F @ 6.0 V  
 C6 — 360 pF, 3 x 120 pF 3.0 kV in parallel  
 C10 — 10  $\mu$ F, 100 V  
 R1 — 10  $\Omega$ , 10 Watt  
 R2 — 10  $\Omega$ , 1.0 Watt

CR1 — 1N4997 or equivalent  
 L1 — 3 Turns, #16 Wire, 0.4" I.D., 0.3" Long  
 L2 — 0.8  $\mu$ H, Ohmite Z-235 or equivalent  
 L3 — 12 Turns, #16 Enameled Wire Closewound 0.25" I.D.  
 L4 — 4 Turns, 1/8" Copper Tubing, 0.6" I.D., 1.0" Long  
 L5, L6 — 2.0  $\mu$ H, Fair-Rite 2643021801 Ferrite bead each or equivalent

Figure 1. 30 MHz Test Circuit Schematic

## The RF Line NPN Silicon Power Transistor 250W, 30MHz, 50V

Rev. V1

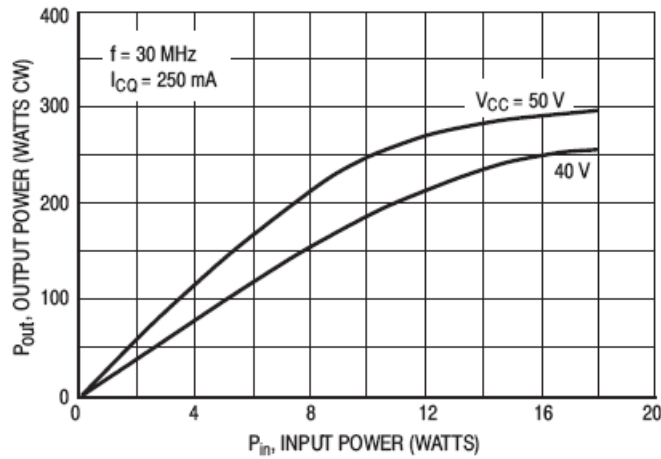

Figure 2. Output Power versus Input Power

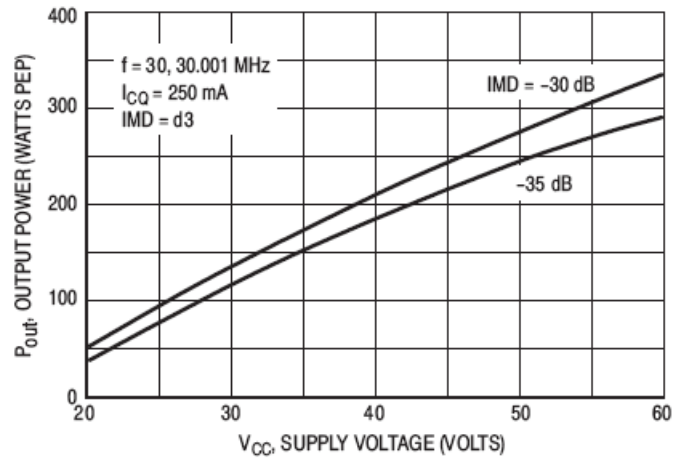

Figure 3. Output Power versus Supply Voltage

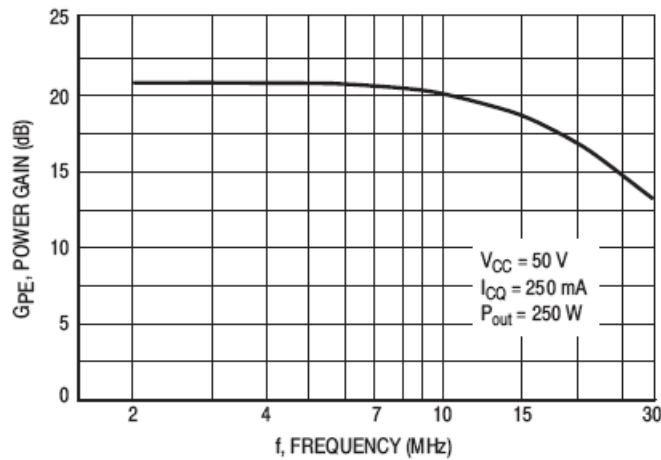

Figure 4. Power Gain versus Frequency

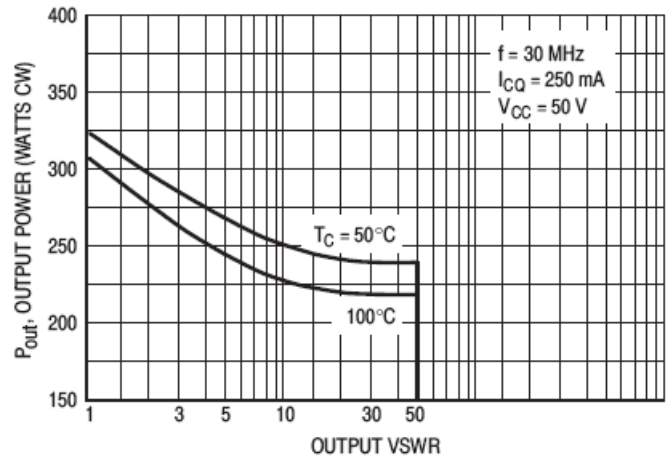

Figure 5. RF SOAR (Class AB)  
P<sub>out</sub> versus Output VSWR

## The RF Line NPN Silicon Power Transistor 250W, 30MHz, 50V

Rev. V1

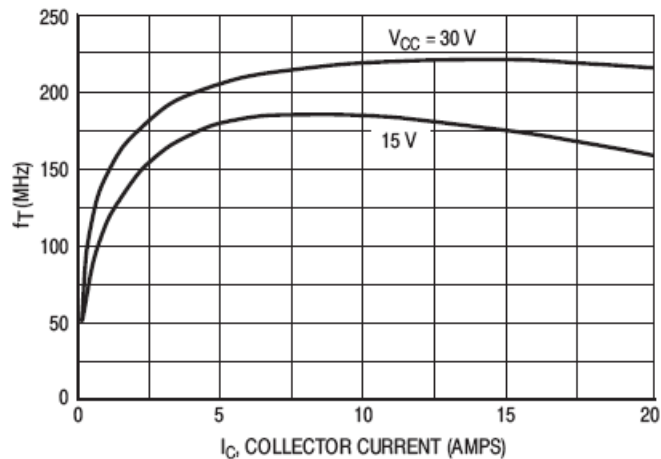

Figure 6.  $f_T$  versus Collector Current

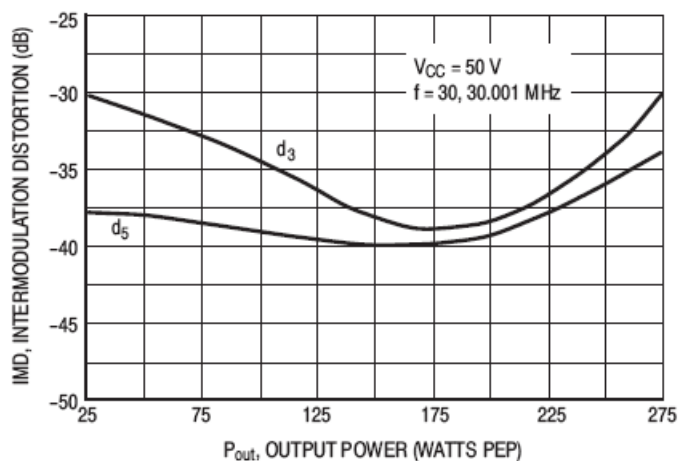

Figure 7. IMD versus  $P_{Out}$

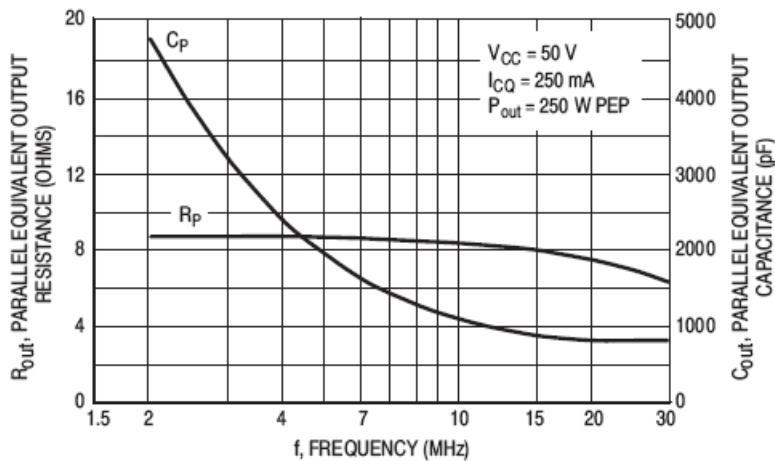
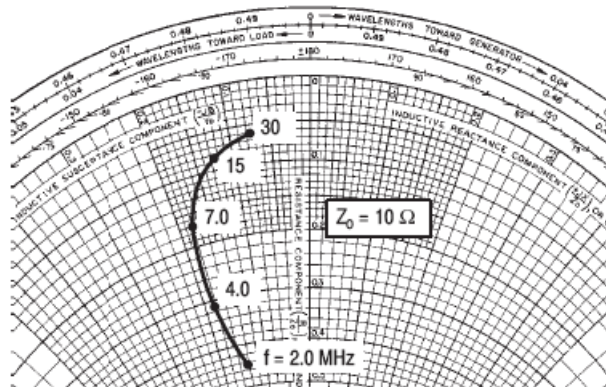

Figure 8. Output Resistance and Capacitance versus Frequency



$V_{CC} = 50\text{ V}$   
 $I_{CQ} = 150\text{ mA}$   
 $P_{out} = 250\text{ W PEP}$

f MHz	$Z_{in}$ Ohms
2.0	4.50 - j1.40
4.0	3.10 - j1.80
7.0	1.70 - j1.75
15	0.80 - j1.25
30	0.60 - j0.75

Figure 9. Series Equivalent Impedance

## The RF Line NPN Silicon Power Transistor 250W, 30MHz, 50V

Rev. V1

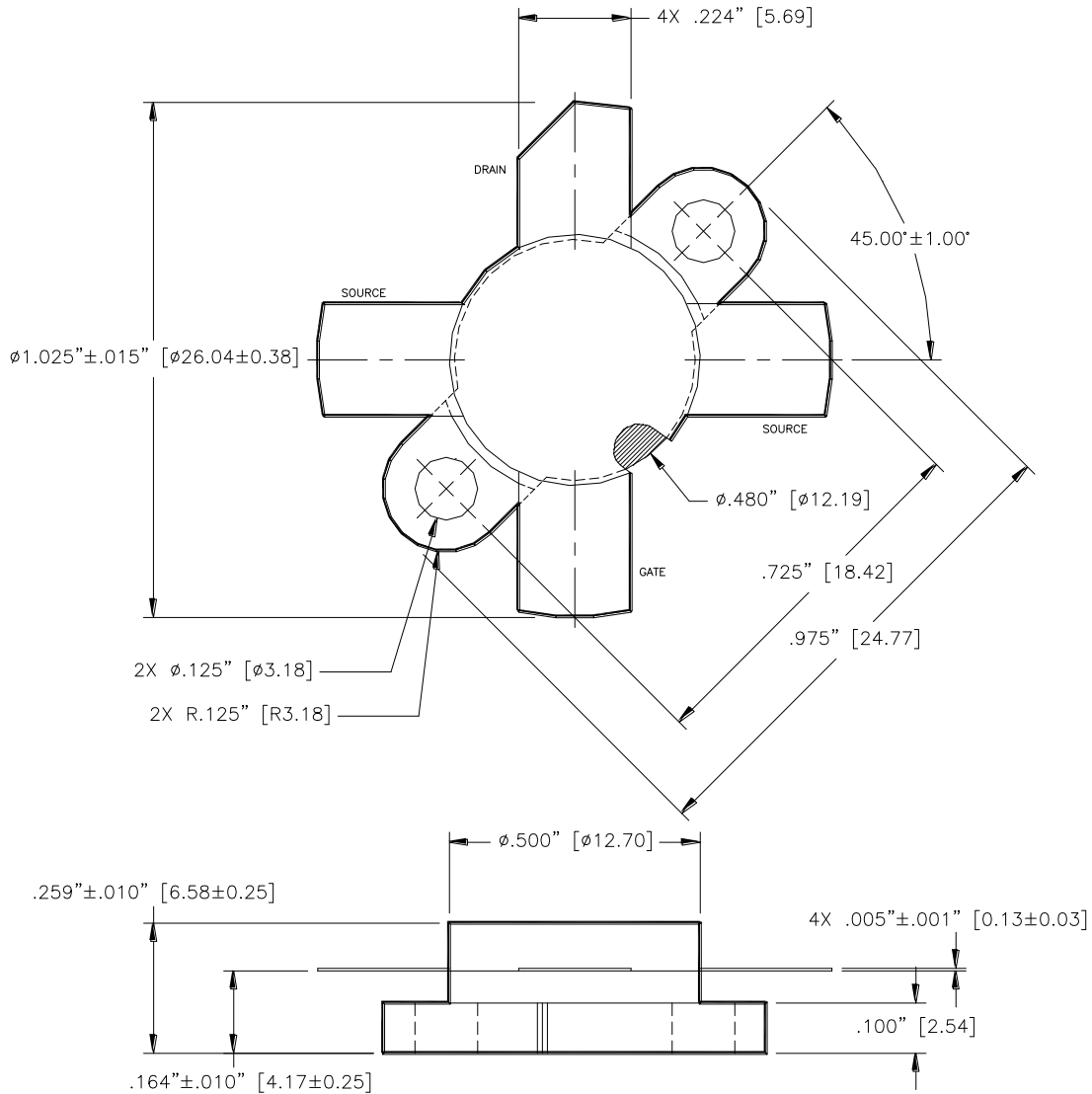

Unless otherwise noted, tolerances are inches  $\pm 0.005''$  [millimeters  $\pm 0.13\text{mm}$ ]

M/A-COM Technology Solutions Inc. All rights reserved.

Information in this document is provided in connection with M/A-COM Technology Solutions Inc ("MACOM") products. These materials are provided by MACOM as a service to its customers and may be used for informational purposes only. Except as provided in MACOM's Terms and Conditions of Sale for such products or in any separate agreement related to this document, MACOM assumes no liability whatsoever. MACOM assumes no responsibility for errors or omissions in these materials. MACOM may make changes to specifications and product descriptions at any time, without notice. MACOM makes no commitment to update the information and shall have no responsibility whatsoever for conflicts or incompatibilities arising from future changes to its specifications and product descriptions. No license, express or implied, by estoppel or otherwise, to any intellectual property rights is granted by this document.

THESE MATERIALS ARE PROVIDED "AS IS" WITHOUT WARRANTY OF ANY KIND, EITHER EXPRESS OR IMPLIED, RELATING TO SALE AND/OR USE OF MACOM PRODUCTS INCLUDING LIABILITY OR WARRANTIES RELATING TO FITNESS FOR A PARTICULAR PURPOSE, CONSEQUENTIAL OR INCIDENTAL DAMAGES, MERCHANTABILITY, OR INFRINGEMENT OF ANY PATENT, COPYRIGHT OR OTHER INTELLECTUAL PROPERTY RIGHT. MACOM FURTHER DOES NOT WARRANT THE ACCURACY OR COMPLETENESS OF THE INFORMATION, TEXT, GRAPHICS OR OTHER ITEMS CONTAINED WITHIN THESE MATERIALS. MACOM SHALL NOT BE LIABLE FOR ANY SPECIAL, INDIRECT, INCIDENTAL, OR CONSEQUENTIAL DAMAGES, INCLUDING WITHOUT LIMITATION, LOST REVENUES OR LOST PROFITS, WHICH MAY RESULT FROM THE USE OF THESE MATERIALS.

MACOM products are not intended for use in medical, lifesaving or life sustaining applications. MACOM customers using or selling MACOM products for use in such applications do so at their own risk and agree to fully indemnify MACOM for any damages resulting from such improper use or sale.

## Looking for pricing, stock, or lifecycle information?

Click below to explore more details on WIN SOURCE:

- ⊖ [View MRF448 on WIN SOURCE](#)
- ⊖ [M/A-Com Technology Solutions Information](#)

## Optimize Your Supply Chain with WIN SOURCE Solutions

- ✓ Global Sourcing Solution
- ✓ Obsolete Management
- ✓ Cost Control Management
- ✓ Shortage Management
- ✓ Alternative Solution
- ✓ Excess Inventory Management