



**THE DATASHEET OF  
MRF6S27015G NR1**



# RF Power Field Effect Transistors

## N-Channel Enhancement-Mode Lateral MOSFETs

Designed for CDMA base station applications with frequencies from 2000 to 2700 MHz. Suitable for WiMAX, WiBro, BWA, and OFDM multicarrier Class AB and Class C amplifier applications.

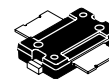
- Typical Single-Carrier W-CDMA Performance:  $V_{DD} = 28$  Volts,  $I_{DQ} = 160$  mA,  $P_{out} = 3$  Watts Avg.,  $f = 2600$  MHz, Channel Bandwidth = 3.84 MHz, PAR = 8.5 dB @ 0.01% Probability on CCDF.  
 Power Gain — 14 dB  
 Drain Efficiency — 22%  
 ACPR @ 5 MHz Offset — -45 dBc in 3.84 MHz Channel Bandwidth
- Capable of Handling 5:1 VSWR, @ 28 Vdc, 2600 MHz, 15 Watts CW Output Power

### Features

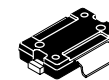
- Characterized with Series Equivalent Large-Signal Impedance Parameters
- Internally Matched for Ease of Use
- Qualified Up to a Maximum of 32  $V_{DD}$  Operation
- Integrated ESD Protection
- 225°C Capable Plastic Package
- RoHS Compliant
- In Tape and Reel. R1 Suffix = 500 Units per 24 mm, 13 inch Reel.

**MRF6S27015NR1**  
**MRF6S27015GNR1**

**2300-2700 MHz, 3 W AVG., 28 V**  
**SINGLE W-CDMA**  
**LATERAL N-CHANNEL**  
**RF POWER MOSFETs**



**CASE 1265-09, STYLE 1**  
**TO-270-2**  
**PLASTIC**  
**MRF6S27015NR1**



**CASE 1265A-03, STYLE 1**  
**TO-270-2 GULL**  
**PLASTIC**  
**MRF6S27015GNR1**

**Table 1. Maximum Ratings**

Rating	Symbol	Value	Unit
Drain-Source Voltage	$V_{DSS}$	-0.5, +68	Vdc
Gate-Source Voltage	$V_{GS}$	-0.5, +12	Vdc
Storage Temperature Range	$T_{stg}$	-65 to +150	°C
Case Operating Temperature	$T_C$	150	°C
Operating Junction Temperature (1,2)	$T_J$	225	°C

**Table 2. Thermal Characteristics**

Characteristic	Symbol	Value (2,3)	Unit
Thermal Resistance, Junction to Case Case Temperature 80°C, 7.5 W Avg., Two-Tone Case Temperature 79°C, 3 W CW	$R_{\theta JC}$	2.0 2.2	°C/W

1. Continuous use at maximum temperature will affect MTTF.
2. MTTF calculator available at <http://www.freescale.com/rf>. Select Software & Tools/Development Tools/Calculators to access MTTF calculators by product.
3. Refer to AN1955, *Thermal Measurement Methodology of RF Power Amplifiers*. Go to <http://www.freescale.com/rf>. Select Documentation/Application Notes - AN1955.

**Table 3. ESD Protection Characteristics**

Test Methodology	Class
Human Body Model (per JESD22-A114)	1A (Minimum)
Machine Model (per EIA/JESD22-A115)	A (Minimum)
Charge Device Model (per JESD22-C101)	IV (Minimum)

**Table 4. Moisture Sensitivity Level**

Test Methodology	Rating	Package Peak Temperature	Unit
Per JESD 22-A113, IPC/JEDEC J-STD-020	3	260	°C

**Table 5. Electrical Characteristics** ( $T_C = 25^\circ\text{C}$  unless otherwise noted)

Characteristic	Symbol	Min	Typ	Max	Unit
----------------	--------	-----	-----	-----	------

**Off Characteristics**

Zero Gate Voltage Drain Leakage Current ( $V_{DS} = 68\text{ Vdc}$ , $V_{GS} = 0\text{ Vdc}$ )	$I_{DSS}$	—	—	10	$\mu\text{Adc}$
Zero Gate Voltage Drain Leakage Current ( $V_{DS} = 28\text{ Vdc}$ , $V_{GS} = 0\text{ Vdc}$ )	$I_{DSS}$	—	—	1	$\mu\text{Adc}$
Gate-Source Leakage Current ( $V_{GS} = 5\text{ Vdc}$ , $V_{DS} = 0\text{ Vdc}$ )	$I_{GSS}$	—	—	500	nAdc

**On Characteristics**

Gate Threshold Voltage ( $V_{DS} = 10\text{ Vdc}$ , $I_D = 40\ \mu\text{Adc}$ )	$V_{GS(th)}$	1.5	2.2	3.5	Vdc
Gate Quiescent Voltage ( $V_{DS} = 28\text{ Vdc}$ , $I_D = 160\text{ mAdc}$ )	$V_{GS(Q)}$	—	2.8	—	Vdc
Fixture Gate Quiescent Voltage (1) ( $V_{DD} = 28\text{ Vdc}$ , $I_D = 160\text{ mAdc}$ , Measured in Functional Test)	$V_{GG(Q)}$	2.2	3.1	4.4	Vdc
Drain-Source On-Voltage ( $V_{GS} = 10\text{ Vdc}$ , $I_D = 0.4\text{ Adc}$ )	$V_{DS(on)}$	—	0.27	0.4	Vdc

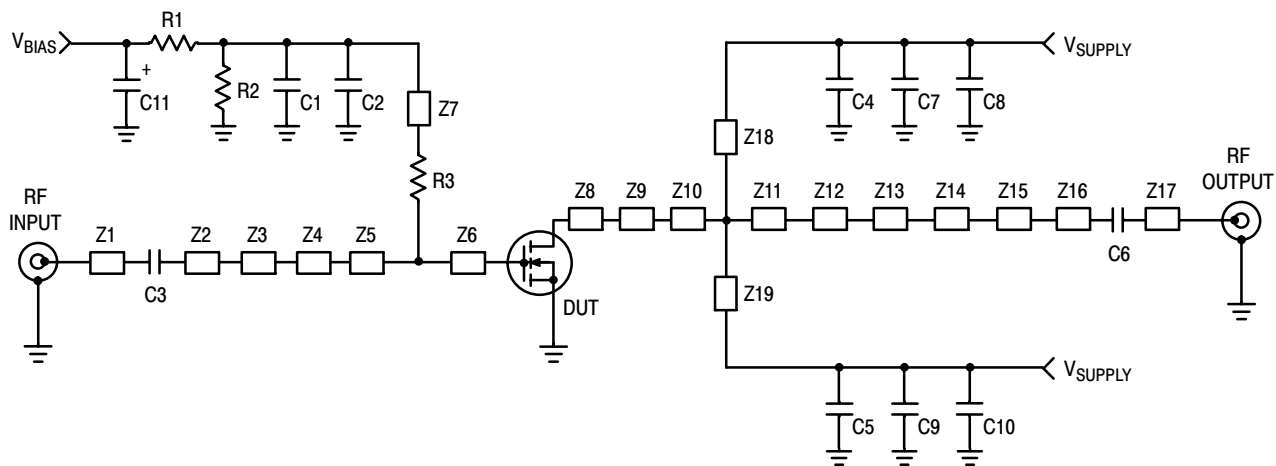
**Dynamic Characteristics (2)**

Reverse Transfer Capacitance ( $V_{DS} = 28\text{ Vdc} \pm 30\text{ mV(rms)ac}$ @ 1 MHz, $V_{GS} = 0\text{ Vdc}$ )	$C_{rss}$	—	11.6	—	pF
Output Capacitance ( $V_{DS} = 28\text{ Vdc} \pm 30\text{ mV(rms)ac}$ @ 1 MHz, $V_{GS} = 0\text{ Vdc}$ )	$C_{oss}$	—	22.9	—	pF

**Functional Tests (3)** (In Freescale Test Fixture, 50 ohm system)  $V_{DD} = 28\text{ Vdc}$ ,  $I_{DQ} = 160\text{ mA}$ ,  $P_{out} = 3\text{ W Avg.}$ ,  $f = 2600\text{ MHz}$ , Single-Carrier W-CDMA, 3.84 MHz Channel Bandwidth Carriers. ACPR measured in 3.84 MHz Channel Bandwidth @  $\pm 5\text{ MHz}$  Offset. PAR = 8.5 dB @ 0.01% Probability on CCDF.

Power Gain	$G_{ps}$	12.5	14	16	dB
Drain Efficiency	$\eta_D$	19	22	—	%
Adjacent Channel Power Ratio	ACPR	—	-45	-42	dBc
Input Return Loss	IRL	—	-18	-9	dB

- $V_{GG} = 11/10 \times V_{GS(Q)}$ . Parameter measured on Freescale Test Fixture, due to resistive divider network on the board. Refer to Test Circuit schematic.
- Part internally input matched.
- Measurement made with device in straight lead configuration before any lead forming operation is applied.



Z1	0.503" x 0.066" Microstrip	Z11	0.143" x 0.816" Microstrip
Z2	0.905" x 0.066" Microstrip	Z12	0.101" x 0.667" Microstrip
Z3	0.371" x 0.300" x 0.049" Taper	Z13	0.073" x 0.485" Microstrip
Z4	0.041" x 0.016" Microstrip	Z14	0.120" x 0.021" Microstrip
Z5	0.245" x 0.851" Microstrip	Z15	0.407" x 0.170" Microstrip
Z6	0.248" x 0.851" Microstrip	Z16	0.714" x 0.066" Microstrip
Z7	0.973" x 0.050" Microstrip	Z17	0.496" x 0.066" Microstrip
Z8	0.085" x 0.485" Microstrip	Z18	0.475" x 0.050" Microstrip
Z9	0.091" x 0.667" Microstrip	Z19	0.480" x 0.050" Microstrip
Z10	0.138" x 0.816" Microstrip	PCB	Taconic RF-35, 0.030", $\epsilon_r = 3.5$

**Figure 1. MRF6S27015NR1(GNR1) Test Circuit Schematic**

**Table 6. MRF6S27015NR1(GNR1) Test Circuit Component Designations and Values**

Part	Description	Part Number	Manufacturer
C1	100 nF Chip Capacitor	CDR33BX104AKYS	Kemet
C2	4.7 pF Chip Capacitor	ATC100B4R7BT500XT	ATC
C3	9.1 pF Chip Capacitor	ATC100B9R1BT500XT	ATC
C4, C5, C6	8.2 pF Chip Capacitors	ATC100B8R2BT500XT	ATC
C7, C8, C9, C10	10 $\mu$ F, 50 V Chip Capacitors	GRM55DR61H106KA88L	Murata
C11	10 $\mu$ F, 35 V Tantalum Chip Capacitor	T491D106K035AT	Kemet
R1	1 K $\Omega$ , 1/4 W Chip Resistor	CRCW12061001FKEA	Vishay
R2	10 K $\Omega$ , 1/4 W Chip Resistor	CRCW12061002FKEA	Vishay
R3	10 $\Omega$ , 1/4 W Chip Resistor	CRCW120610R0FKEA	Vishay

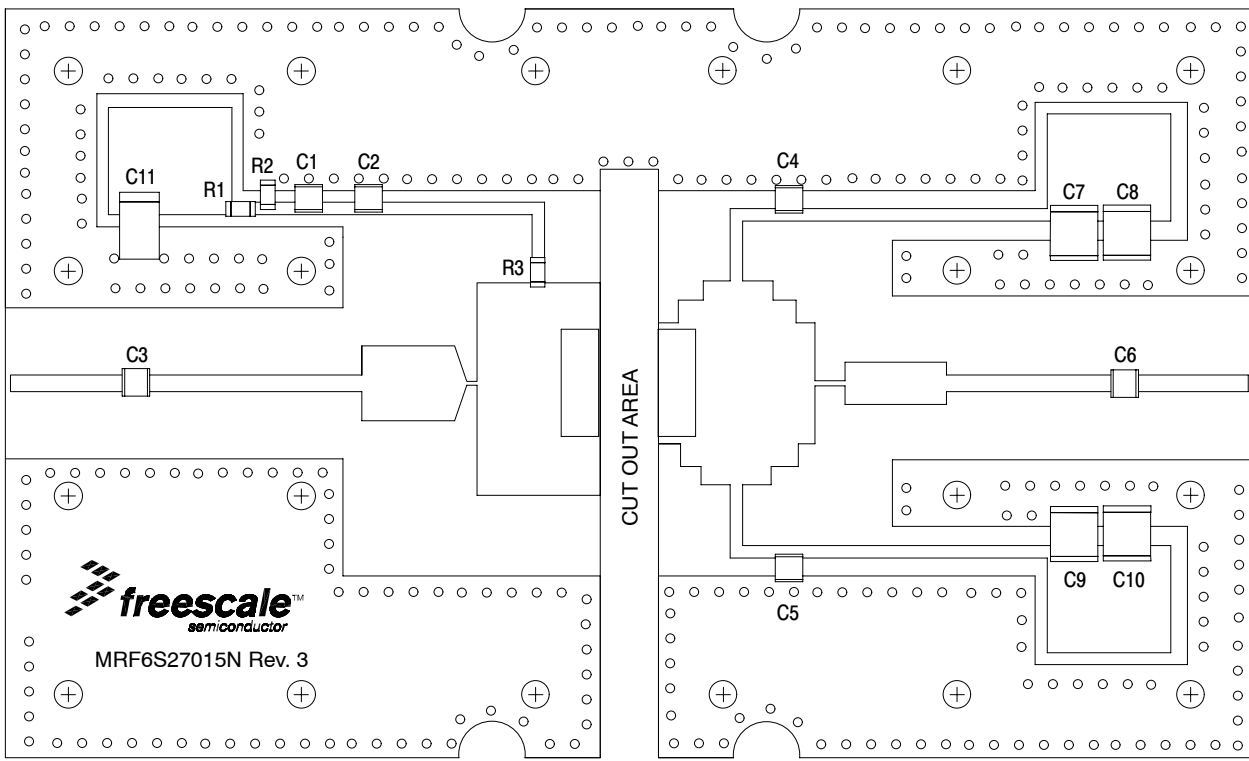
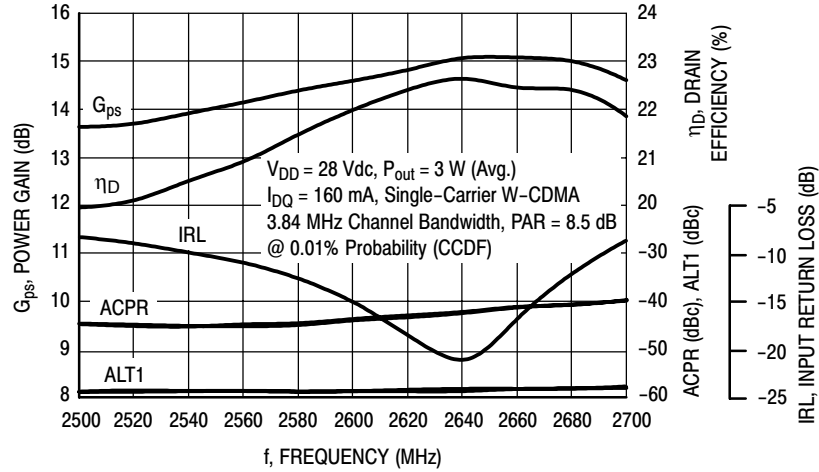
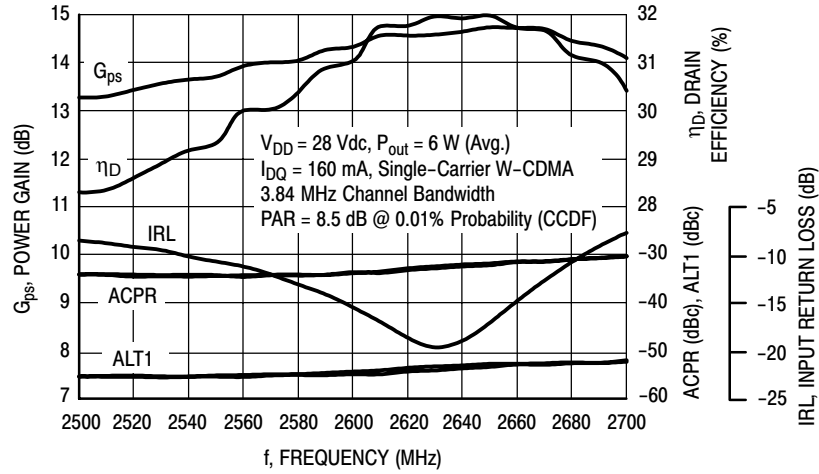


Figure 2. MRF6S27015NR1(GNR1) Test Circuit Component Layout

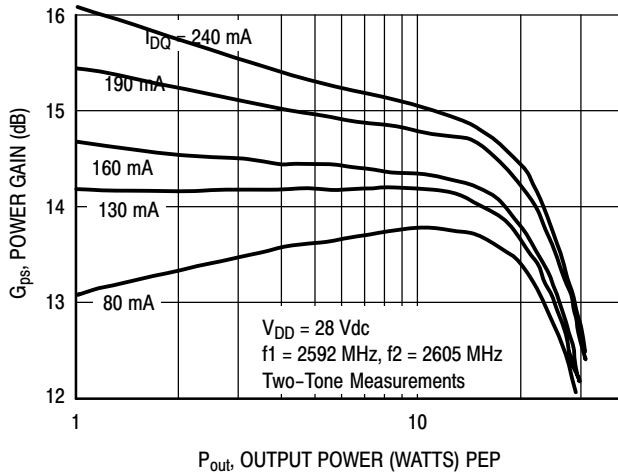
### TYPICAL CHARACTERISTICS



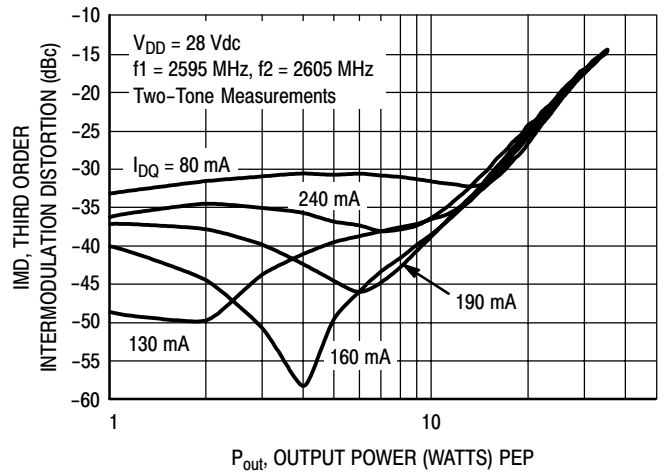
**Figure 3. Single-Carrier W-CDMA Broadband Performance @  $P_{out} = 3$  Watts Avg.**



**Figure 4. Single-Carrier W-CDMA Broadband Performance @  $P_{out} = 6$  Watts Avg.**

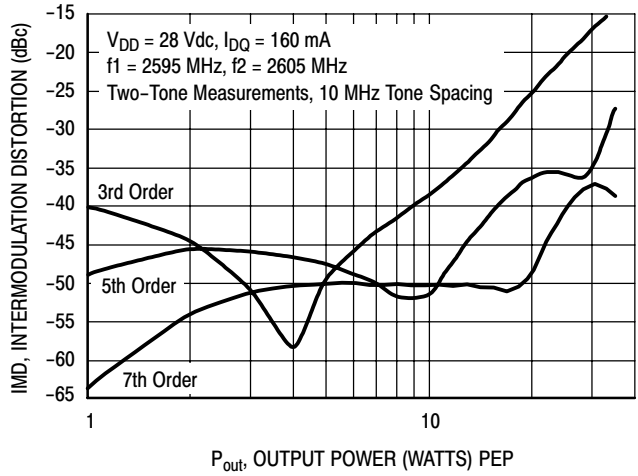


**Figure 5. Two-Tone Power Gain versus Output Power**

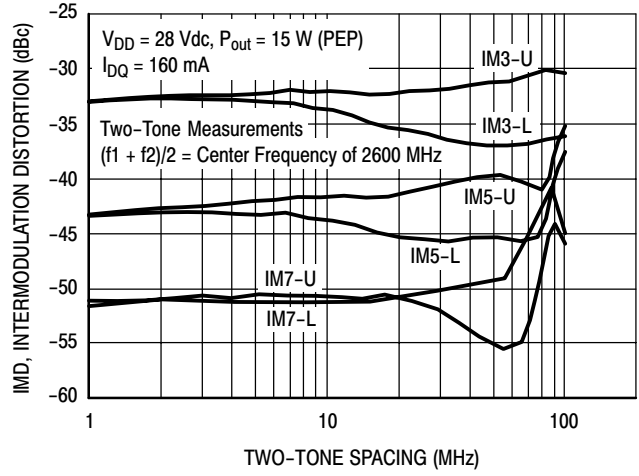


**Figure 6. Third Order Intermodulation Distortion versus Output Power**

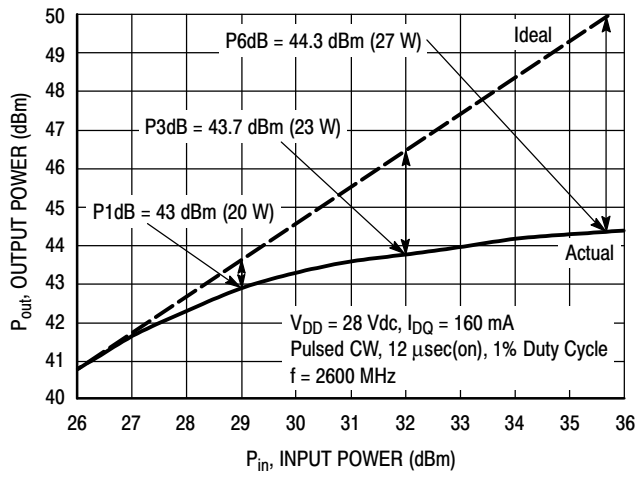
### TYPICAL CHARACTERISTICS



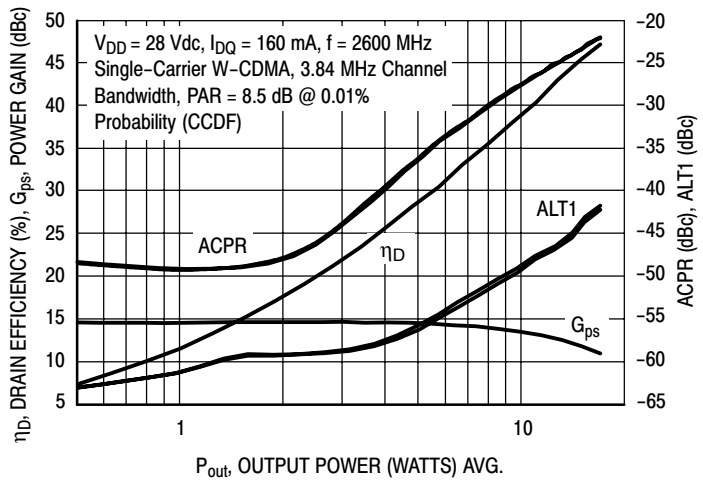
**Figure 7. Intermodulation Distortion Products versus Output Power**



**Figure 8. Intermodulation Distortion Products versus Tone Spacing**

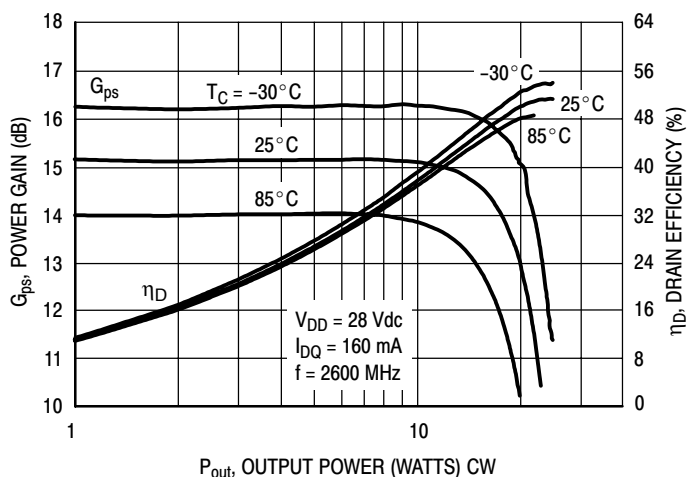


**Figure 9. Pulsed CW Output Power versus Input Power**

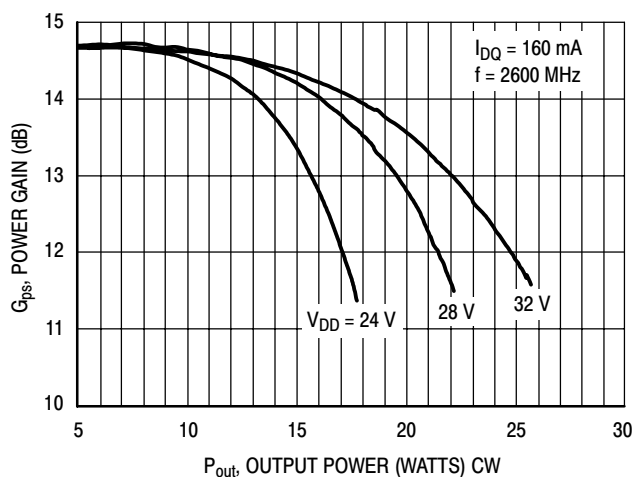


**Figure 10. Single-Carrier W-CDMA ACPR, ALT1, Power Gain and Drain Efficiency versus Output Power**

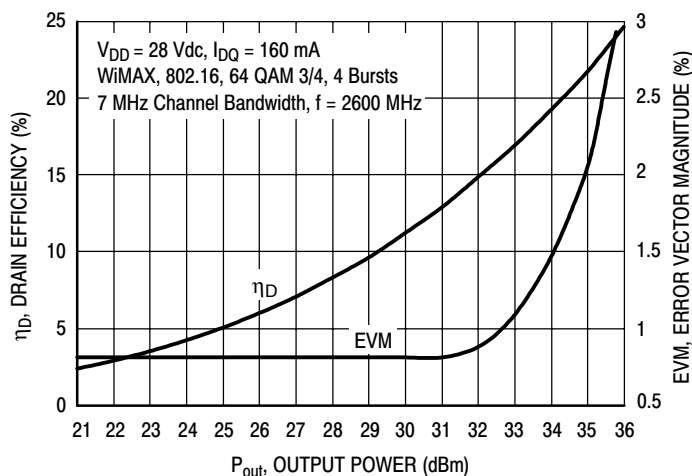
### TYPICAL CHARACTERISTICS



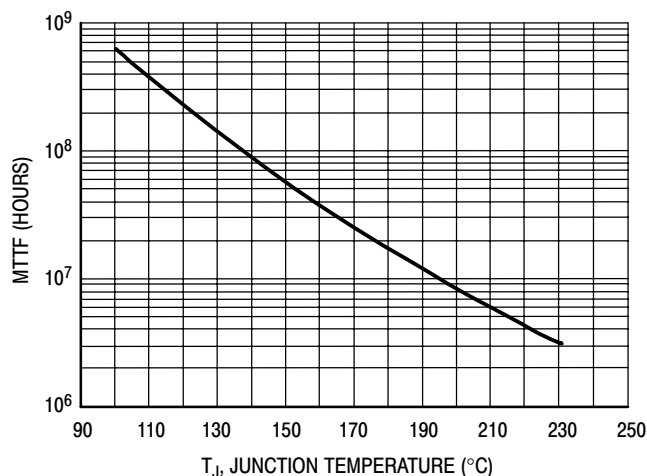
**Figure 11. Power Gain and Drain Efficiency versus CW Output Power**



**Figure 12. Power Gain versus Output Power**



**Figure 13. Drain Efficiency and Error Vector Magnitude versus Output Power**

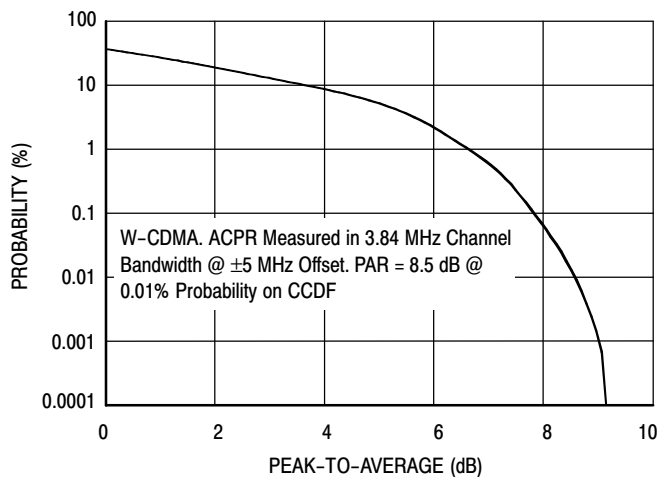


This above graph displays calculated MTTF in hours when the device is operated at  $V_{DD} = 28$  Vdc,  $P_{out} = 3$  W Avg., and  $\eta_D = 22\%$ .

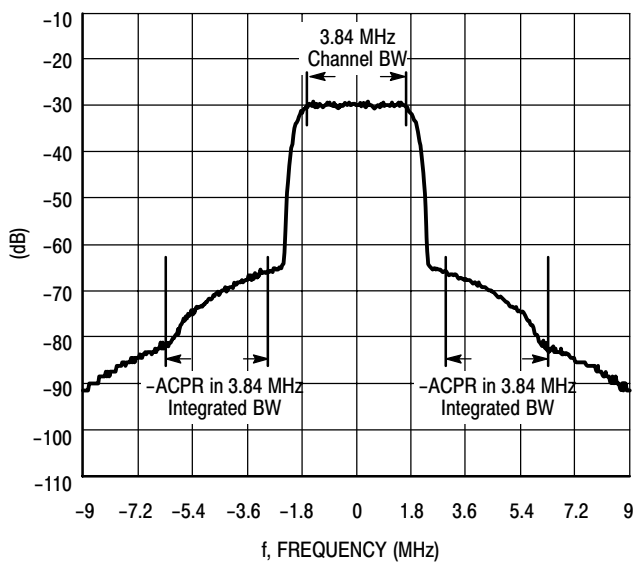
MTTF calculator available at <http://www.freescale.com/rf>. Select Software & Tools/Development Tools/Calculators to access MTTF calculators by product.

**Figure 14. MTTF versus Junction Temperature**

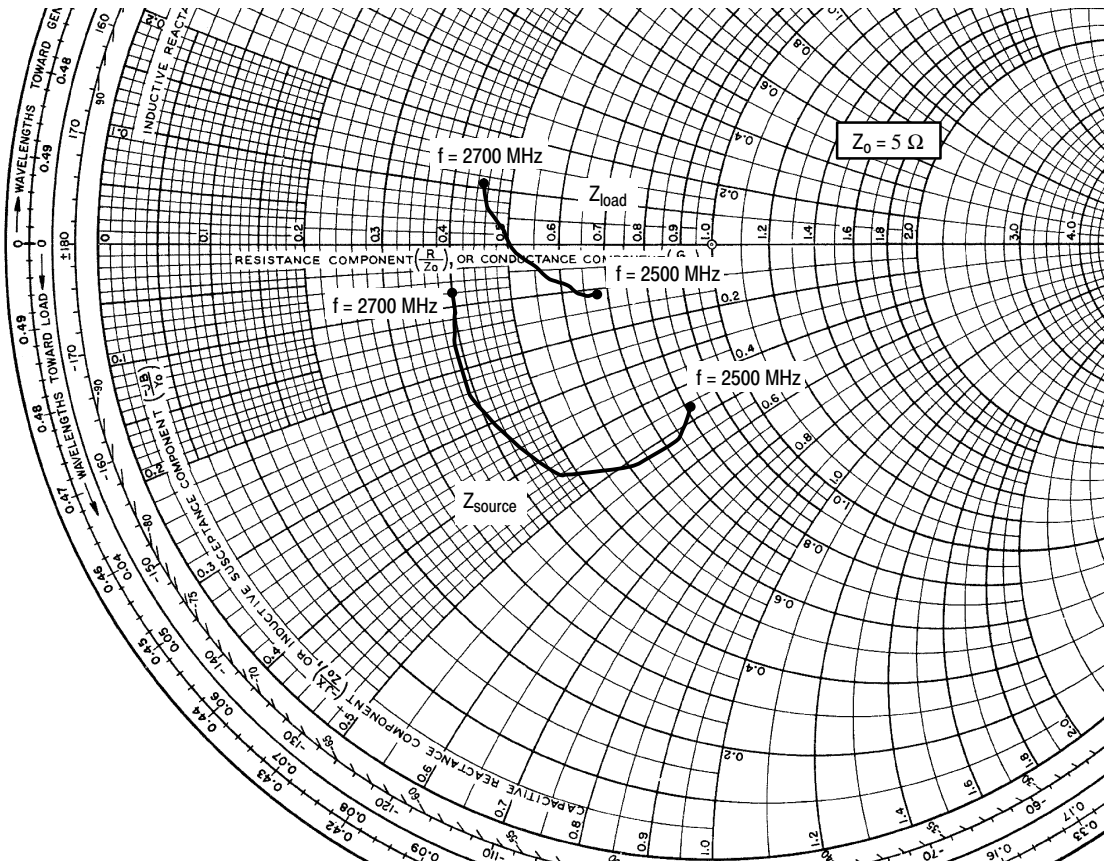
### W-CDMA TEST SIGNAL



**Figure 15. CCDF W-CDMA 3GPP, Test Model 1, 64 DPCH, 67% Clipping, Single-Carrier Test Signal**



**Figure 16. Single-Carrier W-CDMA Spectrum**



$V_{DD} = 28 \text{ Vdc}$ ,  $I_{DQ} = 160 \text{ mA}$ ,  $P_{out} = 3 \text{ W Avg.}$

f MHz	$Z_{source}$ $\Omega$	$Z_{load}$ $\Omega$
2500	$4.059 - j2.284$	$3.380 - j0.543$
2525	$3.679 - j2.593$	$3.265 - j0.546$
2550	$3.006 - j2.574$	$3.077 - j0.449$
2575	$2.355 - j2.190$	$2.892 - j0.336$
2600	$2.075 - j1.657$	$2.727 - j0.182$
2625	$1.930 - j1.179$	$2.564 - j0.034$
2650	$1.973 - j0.771$	$2.435 + j0.140$
2675	$2.017 - j0.557$	$2.286 + j0.340$
2700	$2.024 - j0.379$	$2.227 + j0.538$

$Z_{source}$  = Test circuit impedance as measured from gate to ground.

$Z_{load}$  = Test circuit impedance as measured from drain to ground.

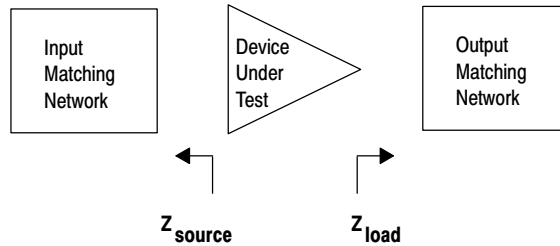


Figure 17. Series Equivalent Source and Load Impedance

**Table 7. Common Source Scattering Parameters** ( $V_{DD} = 28\text{ V}$ ,  $I_{DQ} = 160\text{ mA}$ ,  $T_C = 25^\circ\text{C}$ , 50 ohm system)

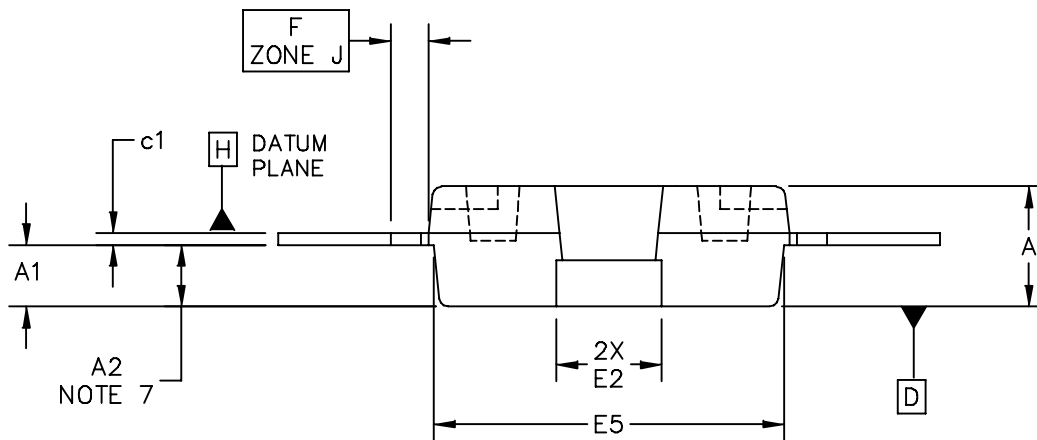
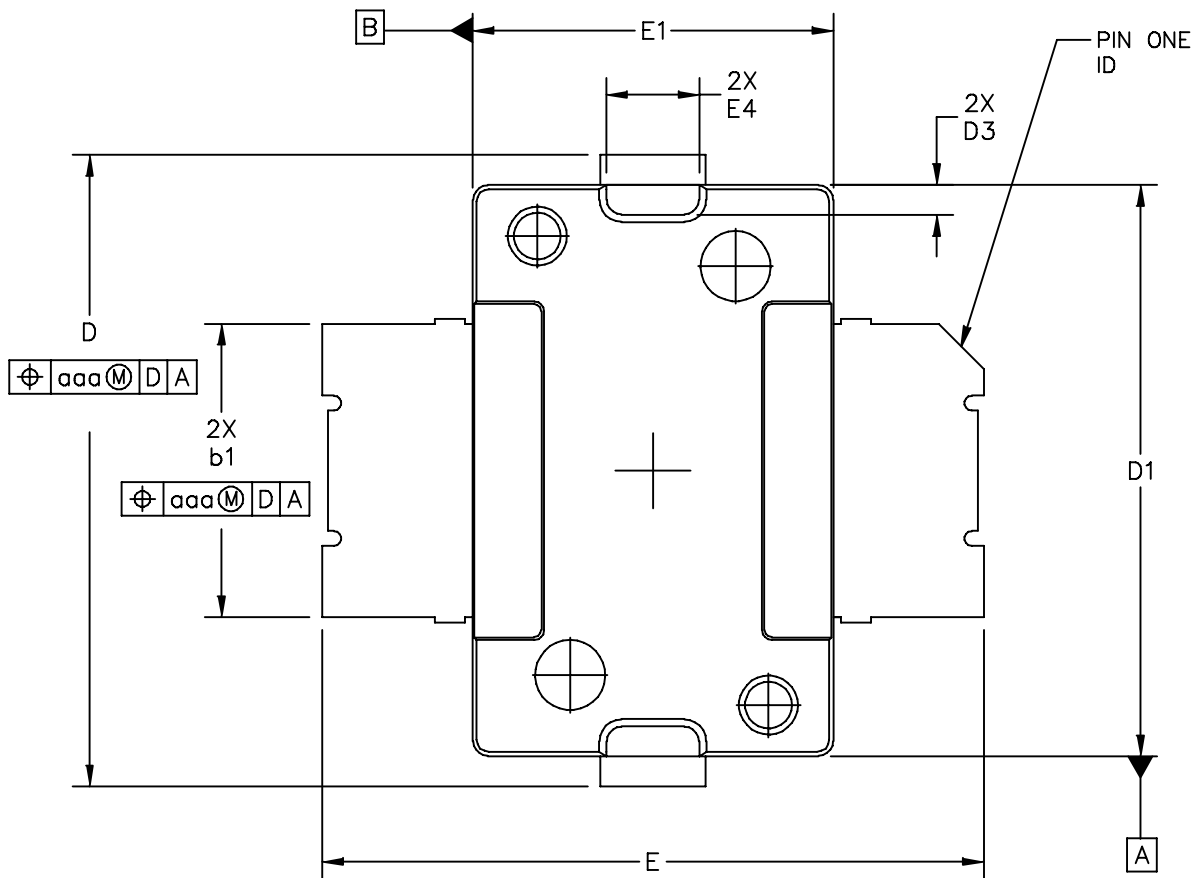
f MHz	S <sub>11</sub>		S <sub>21</sub>		S <sub>12</sub>		S <sub>22</sub>	
	S <sub>11</sub>	∠ φ	S <sub>21</sub>	∠ φ	S <sub>12</sub>	∠ φ	S <sub>22</sub>	∠ φ
500	0.984	-178.2	1.453	39.2	0.001	-109.8	0.870	-122.3
550	0.984	-179.0	1.180	36.5	0.000	-121.0	0.888	-127.6
600	0.986	180.0	0.958	34.4	0.000	159.6	0.901	-132.0
650	0.987	179.0	0.776	33.0	0.001	118.4	0.911	-135.8
700	0.987	178.1	0.627	32.3	0.001	106.5	0.921	-139.1
750	0.986	177.3	0.502	32.5	0.001	104.2	0.931	-142.1
800	0.985	176.5	0.397	34.1	0.002	96.0	0.940	-144.8
850	0.985	175.8	0.308	37.7	0.002	95.6	0.944	-147.3
900	0.984	175.1	0.235	44.5	0.003	94.0	0.951	-149.5
950	0.983	174.5	0.180	56.5	0.003	91.2	0.956	-151.5
1000	0.982	173.8	0.146	75.6	0.003	91.2	0.962	-153.4
1050	0.981	173.2	0.142	98.9	0.004	89.9	0.965	-155.2
1100	0.980	172.5	0.163	118.0	0.004	89.2	0.969	-156.8
1150	0.978	171.9	0.199	129.9	0.005	88.9	0.973	-158.3
1200	0.976	171.2	0.243	136.6	0.005	87.4	0.976	-159.8
1250	0.974	170.5	0.291	140.2	0.006	86.5	0.980	-161.1
1300	0.970	169.8	0.342	141.8	0.006	86.3	0.983	-162.4
1350	0.966	169.0	0.395	142.1	0.006	84.6	0.986	-163.7
1400	0.960	168.3	0.452	141.5	0.006	84.8	0.988	-164.9
1450	0.953	167.5	0.514	140.2	0.007	86.9	0.990	-166.1
1500	0.945	166.6	0.580	138.4	0.007	92.5	0.993	-167.3
1550	0.933	165.8	0.655	135.9	0.009	100.3	0.992	-168.4
1600	0.918	164.9	0.738	132.5	0.011	93.7	0.994	-169.4
1650	0.901	164.1	0.828	128.4	0.013	83.6	0.996	-170.4
1700	0.879	163.2	0.925	123.5	0.014	75.4	0.997	-171.6
1750	0.850	162.5	1.030	117.6	0.014	69.1	0.998	-172.8
1800	0.815	162.2	1.139	110.8	0.015	62.8	0.995	-173.9
1850	0.775	162.5	1.246	102.7	0.016	55.8	0.991	-175.0
1900	0.734	164.0	1.337	93.6	0.016	48.2	0.984	-176.0
1950	0.700	167.0	1.399	83.5	0.015	40.3	0.976	-176.9
2000	0.683	171.0	1.420	73.1	0.015	33.2	0.966	-177.6
2050	0.687	175.1	1.396	62.9	0.014	26.5	0.957	-178.0
2100	0.710	178.5	1.338	53.4	0.012	22.1	0.951	-178.3
2150	0.741	-179.3	1.259	45.0	0.011	19.8	0.948	-178.6
2200	0.774	-178.2	1.169	37.6	0.010	19.7	0.947	-178.9
2250	0.805	-177.8	1.079	31.1	0.009	19.7	0.947	-179.2
2300	0.832	-177.9	0.993	25.8	0.008	19.6	0.948	-179.5
2350	0.855	-178.2	0.917	21.2	0.007	22.6	0.950	-179.9

(continued)

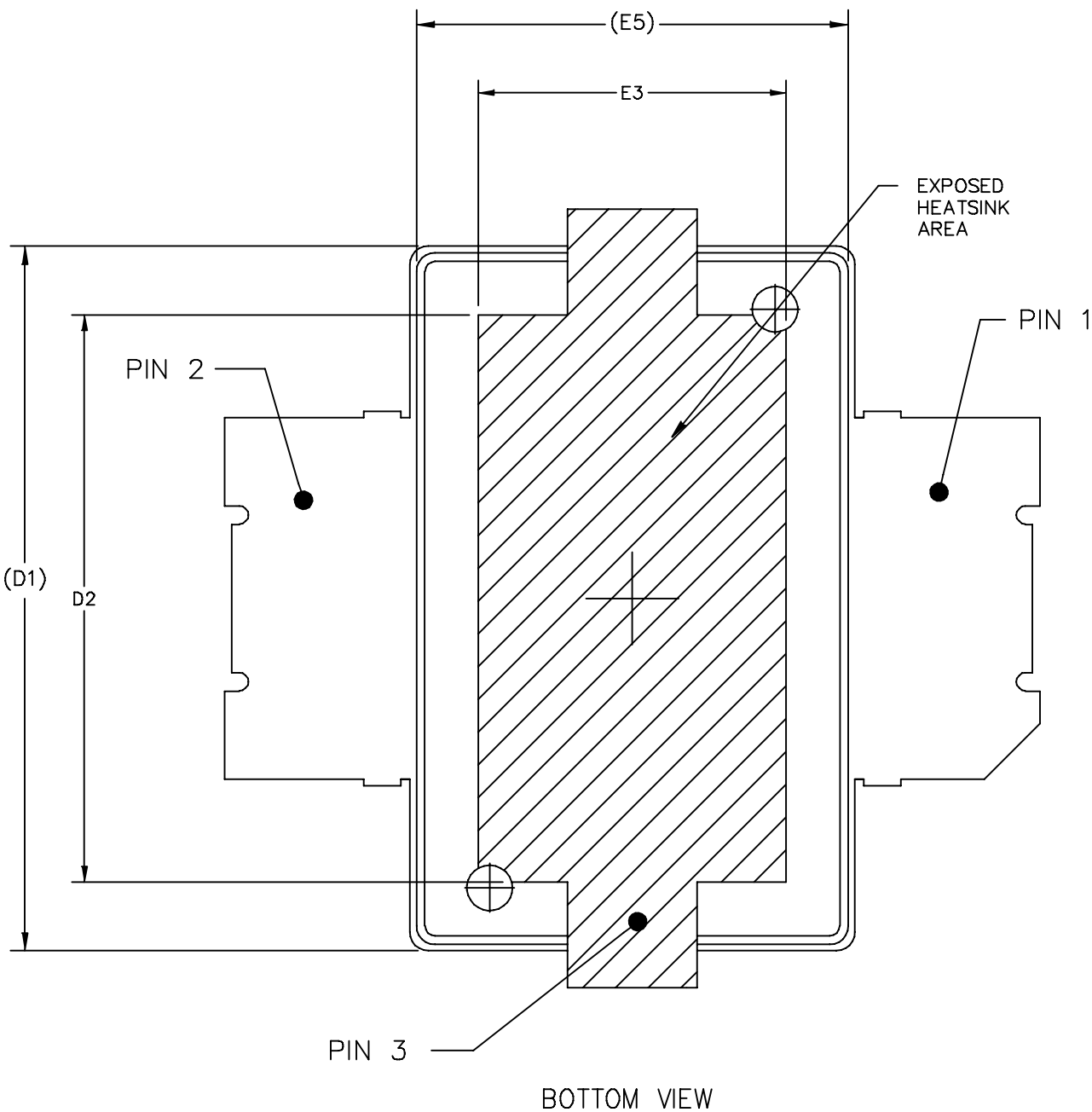
**Table 7. Common Source Scattering Parameters** ( $V_{DD} = 28\text{ V}$ ,  $I_{DQ} = 160\text{ mA}$ ,  $T_C = 25^\circ\text{C}$ , 50 ohm system) (continued)

f MHz	S <sub>11</sub>		S <sub>21</sub>		S <sub>12</sub>		S <sub>22</sub>	
	S <sub>11</sub>	∠ φ	S <sub>21</sub>	∠ φ	S <sub>12</sub>	∠ φ	S <sub>22</sub>	∠ φ
2400	0.873	-178.8	0.848	17.2	0.006	31.2	0.953	179.7
2450	0.887	-179.4	0.786	13.7	0.006	42.2	0.955	179.2
2500	0.897	-179.9	0.731	10.6	0.007	45.6	0.956	178.7
2550	0.907	179.6	0.682	7.9	0.007	46.5	0.957	178.2
2600	0.914	179.1	0.639	5.5	0.007	48.0	0.958	177.8
2650	0.919	178.8	0.600	3.3	0.007	47.0	0.960	177.2
2700	0.926	178.3	0.566	1.3	0.007	45.8	0.962	176.8
2750	0.931	177.9	0.534	-0.6	0.006	52.1	0.964	176.2
2800	0.936	177.4	0.505	-2.2	0.006	62.3	0.965	175.7
2850	0.940	177.0	0.480	-3.8	0.006	69.8	0.966	175.2
2900	0.942	176.6	0.457	-5.2	0.007	73.2	0.967	174.7
2950	0.945	176.3	0.436	-6.5	0.007	78.7	0.968	174.2
3000	0.947	175.8	0.416	-7.6	0.008	85.1	0.969	173.8
3050	0.949	175.6	0.399	-8.7	0.009	87.9	0.969	173.2
3100	0.950	175.1	0.382	-9.6	0.011	88.2	0.970	172.9
3150	0.953	174.8	0.368	-10.5	0.012	86.9	0.972	172.6
3200	0.955	174.5	0.355	-11.5	0.014	85.1	0.974	172.1

**PACKAGE DIMENSIONS**



© FREESCALE SEMICONDUCTOR, INC. ALL RIGHTS RESERVED.	MECHANICAL OUTLINE	PRINT VERSION NOT TO SCALE	
TITLE: TO-270 SURFACE MOUNT	DOCUMENT NO: 98ASH98117A	REV: K	
	CASE NUMBER: 1265-09	29 JUN 2007	
	STANDARD: JEDEC TO-270 AA		



© FREESCALE SEMICONDUCTOR, INC. ALL RIGHTS RESERVED.	MECHANICAL OUTLINE	PRINT VERSION NOT TO SCALE	
TITLE: <div style="text-align: center; padding: 5px;"> <b>TO-270 SURFACE MOUNT</b> </div>	DOCUMENT NO: 98ASH98117A	REV: K	
	CASE NUMBER: 1265-09	29 JUN 2007	
	STANDARD: JEDEC TO-270 AA		

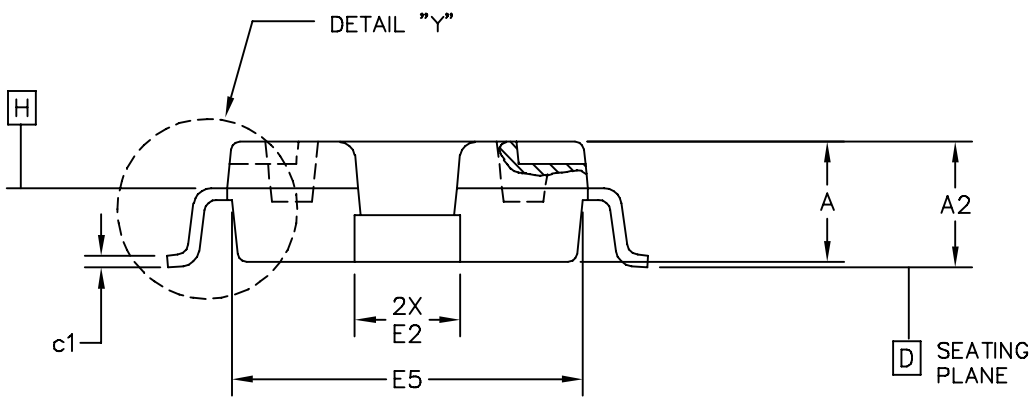
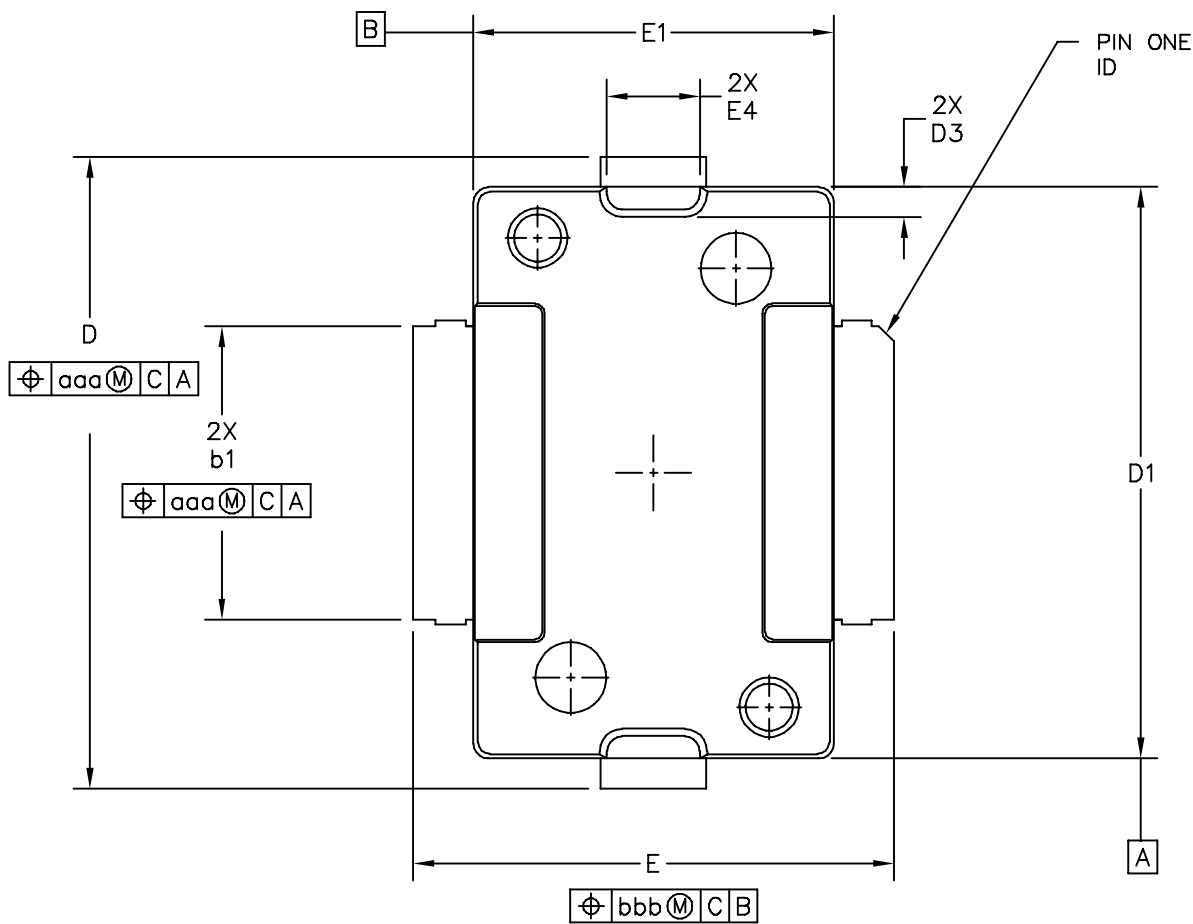
NOTES:

1. CONTROLLING DIMENSION: INCH
2. INTERPRET DIMENSIONS AND TOLERANCES PER ASME Y14.5M-1994.
3. DATUM PLANE -H- IS LOCATED AT TOP OF LEAD AND IS COINCIDENT WITH THE LEAD WHERE THE LEAD EXITS THE PLASTIC BODY AT THE TOP OF THE PARTING LINE.
4. DIMENSIONS "D1" AND "E1" DO NOT INCLUDE MOLD PROTRUSION. ALLOWABLE PROTRUSION IS .006 PER SIDE. DIMENSIONS "D1 AND "E1" DO INCLUDE MOLD MISMATCH AND ARE DETERMINED AT DATUM PLANE -H-.
5. DIMENSION "b1" DOES NOT INCLUDE DAMBAR PROTRUSION. ALLOWABLE DAMBAR PROTRUSION SHALL BE .005 TOTAL IN EXCESS OF THE "b1" DIMENSION AT MAXIMUM MATERIAL CONDITION.
6. DATUMS -A- AND -B- TO BE DETERMINED AT DATUM PLANE -H-.
7. DIMENSION "A2" APPLIES WITHIN ZONE "J" ONLY.
8. DIMENSIONS "D" AND "E2" DO NOT INCLUDE MOLD PROTRUSION. OVERALL LENGTH INCLUDING MOLD PROTRUSION SHOULD NOT EXCEED 0.430 INCH FOR DIMENSION "D" AND 0.080 INCH FOR DIMENSION "E2". DIMENSIONS "D" AND "E2" DO INCLUDE MOLD MISMATCH AND ARE DETERMINED AT DATUM PLANE -D-.

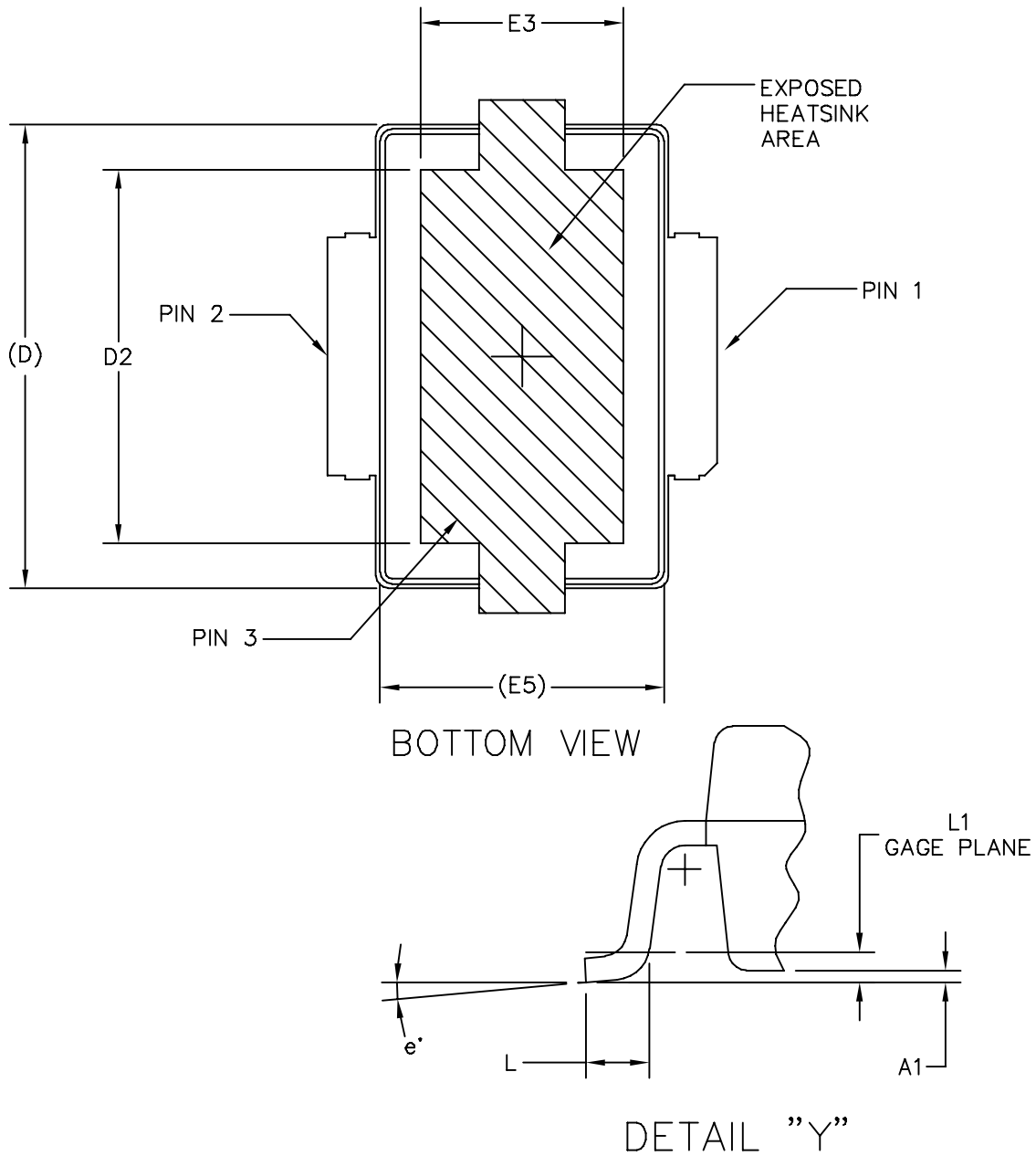
STYLE 1:  
 PIN 1 - DRAIN  
 PIN 2 - GATE  
 PIN 3 - SOURCE

DIM	INCH		MILLIMETER		DIM	INCH		MILLIMETER	
	MIN	MAX	MIN	MAX		MIN	MAX	MIN	MAX
A	.078	.082	1.98	2.08	F	.025 BSC		0.64 BSC	
A1	.039	.043	0.99	1.09	b1	.193	.199	4.90	5.06
A2	.040	.042	1.02	1.07	c1	.007	.011	0.18	0.28
D	.416	.424	10.57	10.77	aaa	.004		0.10	
D1	.378	.382	9.60	9.70					
D2	.290	----	7.37	----					
D3	.016	.024	0.41	0.61					
E	.436	.444	11.07	11.28					
E1	.238	.242	6.04	6.15					
E2	.066	.074	1.68	1.88					
E3	.150	----	3.81	----					
E4	.058	.066	1.47	1.68					
E5	.231	.235	5.87	5.97					

© FREESCALE SEMICONDUCTOR, INC. ALL RIGHTS RESERVED.		MECHANICAL OUTLINE		PRINT VERSION NOT TO SCALE	
TITLE:  TO-270 SURFACE MOUNT			DOCUMENT NO: 98ASH98117A		REV: K
			CASE NUMBER: 1265-09		29 JUN 2007
			STANDARD: JEDEC TO-270 AA		



© FREESCALE SEMICONDUCTOR, INC. ALL RIGHTS RESERVED.		<b>MECHANICAL OUTLINE</b>		PRINT VERSION NOT TO SCALE	
TITLE:  TO-270 GULL WING		DOCUMENT NO: 98ASA99301D		REV: C	
		CASE NUMBER: 1265A-03		02 JUL 2007	
		STANDARD: JEDEC TO-270 BA			



© FREESCALE SEMICONDUCTOR, INC. ALL RIGHTS RESERVED.	<b>MECHANICAL OUTLINE</b>	PRINT VERSION NOT TO SCALE
TITLE: <div style="text-align: center; padding: 5px;"> <b>TO-270 GULL WING</b> </div>	DOCUMENT NO: 98ASA99301D	REV: C
	CASE NUMBER: 1265A-03	02 JUL 2007
	STANDARD: JEDEC TO-270 BA	

NOTES:

1. CONTROLLING DIMENSION: INCH
2. INTERPRET DIMENSIONS AND TOLERANCES PER ASME Y14.5M-1994.
3. DATUM PLANE -H- IS LOCATED AT TOP OF LEAD AND IS COINCIDENT WITH THE LEAD WHERE THE LEAD EXITS THE PLASTIC BODY AT THE TOP OF THE PARTING LINE.
4. DIMENSIONS "D1" AND "E1" DO NOT INCLUDE MOLD PROTRUSION. ALLOWABLE PROTRUSION IS .006 PER SIDE. DIMENSIONS "D1 AND "E1" DO INCLUDE MOLD MISMATCH AND ARE DETERMINED AT DATUM PLANE -H-.
5. DIMENSION b1 DOES NOT INCLUDE DAMBAR PROTRUSION. ALLOWABLE DAMBAR PROTRUSION SHALL BE .005 TOTAL IN EXCESS OF THE b1 DIMENSION AT MAXIMUM MATERIAL CONDITION.
6. DATUMS -A- AND -B- TO BE DETERMINED AT DATUM PLANE -H-.
7. DIMENSIONS "D" AND "E2" DO NOT INCLUDE MOLD PROTRUSION. ALLOWABLE PROTRUSION IS .003 PER SIDE. DIMENSIONS "D AND "E2" DO INCLUDE MOLD MISMATCH AND ARE DETERMINED AT DATUM PLANE -D-.

STYLE 1:

- PIN 1 - DRAIN
- PIN 2 - GATE
- PIN 3 - SOURCE

DIM	INCH		MILLIMETER		DIM	INCH		MILLIMETER	
	MIN	MAX	MIN	MAX		MIN	MAX	MIN	MAX
A	.078	.082	1.98	2.08	L	.018	.024	0.46	0.61
A1	.001	.004	0.02	0.10	L1	.01 BSC		0.25 BSC	
A2	.077	.088	1.96	2.24	b1	.193	.199	4.90	5.06
D	.416	.424	10.57	10.77	c1	.007	.011	0.18	0.28
D1	.378	.382	9.60	9.70	e	2'	8'	2'	8'
D2	.290	-	7.37	-	aaa	.004		0.10	
D3	.016	.024	0.41	0.61					
E	.316	.324	8.03	8.23					
E1	.238	.242	6.04	6.15					
E2	.066	.074	1.68	1.88					
E3	.150	-	3.81	-					
E4	.058	.066	1.47	1.68					
E5	.231	.235	5.87	5.97					
© FREESCALE SEMICONDUCTOR, INC. ALL RIGHTS RESERVED.			<b>MECHANICAL OUTLINE</b>			PRINT VERSION NOT TO SCALE			
TITLE:  TO-270 GULL WING					DOCUMENT NO: 98ASA99301D			REV: C	
					CASE NUMBER: 1265A-03			02 JUL 2007	
					STANDARD: JEDEC TO-270 BA				

## PRODUCT DOCUMENTATION

Refer to the following documents to aid your design process.

### Application Notes

- AN1907: Solder Reflow Attach Method for High Power RF Devices in Plastic Packages
- AN1955: Thermal Measurement Methodology of RF Power Amplifiers

### Engineering Bulletins

- EB212: Using Data Sheet Impedances for RF LDMOS Devices

## REVISION HISTORY

The following table summarizes revisions to this document.

Revision	Date	Description
0	Aug. 2006	<ul style="list-style-type: none"> <li>• Initial Release of Data Sheet</li> </ul>
1	June 2007	<ul style="list-style-type: none"> <li>• Added Case Operating Temperature limit to the Maximum Ratings table and set limit to 150°C, p. 1</li> <li>• Operating Junction Temperature increased from 200°C to 225°C in Maximum Ratings table, related “Continuous use at maximum temperature will affect MTTF” footnote added and changed 200°C to 225°C in Capable Plastic Package bullet, p. 1</li> <li>• Removed footnote and “Measured in Functional Test” from the RF test condition voltage callout for <math>V_{GS(Q)}</math>, and added Fixture Gate Quiescent Voltage, <math>V_{GG(Q)}</math> to On Characteristics table, p. 2</li> <li>• <math>V_{DS(on)}</math> Typ and Min values corrected in On Characteristics table, p. 2</li> <li>• Output Capacitance Typ value corrected in Dynamic Characteristics table, p. 2</li> <li>• Updated Part Numbers in Table 6, Component Designations and Values, to RoHS compliant part numbers, p. 3</li> <li>• Replaced Fig. 14, MTTF versus Junction Temperature with updated graph. Removed Amps<sup>2</sup> and listed operating characteristics and location of MTTF calculator for device, p. 7</li> <li>• Fig. 15, CCDF W-CDMA 3GPP, Test Model 1, 64 DPCH, 50% Clipping, Single-Carrier Test Signal, updated to remove IM3 measurement copy from callout in graph, p. 8</li> <li>• Updated Fig. 16, Single-Carrier W-CDMA Spectrum, to correctly reflect integrated bandwidth offsets, p. 8</li> </ul>
2	Dec. 2008	<ul style="list-style-type: none"> <li>• Changed Typical Performance Full Frequency Band to <math>f = 2600</math> MHz to match Functional Test specification, p. 1</li> <li>• Changed Storage Temperature Range in Max Ratings table from -65 to +175 to -65 to +150 for standardization across products, p. 1</li> <li>• Replaced Case Outline 1265-08 with 1265-09, Issue K, p. 1, 12-14. Corrected cross hatch pattern in bottom view and changed its dimensions (D2 and E3) to minimum value on source contact (D2 changed from Min-Max .290-.320 to .290 Min; E3 changed from Min-Max .150-.180 to .150 Min). Added JEDEC Standard Package Number.</li> <li>• Replaced Case Outline 1265A-02 with 1265A-03, Issue C, p. 1, 15-17. Corrected cross hatch pattern and its dimensions (D2 and E2) on source contact (D2 changed from Min-Max .290-.320 to .290 Min; E3 changed from Min-Max .150-.180 to .150 Min). Added pin numbers. Corrected mm dimension L for gull-wing foot from 4.90-5.06 Min-Max to 0.46-0.61 Min-Max. Added JEDEC Standard Package Number.</li> <li>• Added footnote, Measurement made with device in straight lead configuration before any lead forming operation is applied, to Functional Tests table, p. 2.</li> <li>• Updated Part Numbers in Table 6, Component Designations and Values, to latest RoHS compliant part numbers, p. 3</li> </ul>

## **How to Reach Us:**

### **Home Page:**

[www.freescale.com](http://www.freescale.com)

### **Web Support:**

<http://www.freescale.com/support>

### **USA/Europe or Locations Not Listed:**

Freescale Semiconductor, Inc.  
Technical Information Center, EL516  
2100 East Elliot Road  
Tempe, Arizona 85284  
1-800-521-6274 or +1-480-768-2130  
[www.freescale.com/support](http://www.freescale.com/support)

### **Europe, Middle East, and Africa:**

Freescale Halbleiter Deutschland GmbH  
Technical Information Center  
Schatzbogen 7  
81829 Muenchen, Germany  
+44 1296 380 456 (English)  
+46 8 52200080 (English)  
+49 89 92103 559 (German)  
+33 1 69 35 48 48 (French)  
[www.freescale.com/support](http://www.freescale.com/support)

### **Japan:**

Freescale Semiconductor Japan Ltd.  
Headquarters  
ARCO Tower 15F  
1-8-1, Shimo-Meguro, Meguro-ku,  
Tokyo 153-0064  
Japan  
0120 191014 or +81 3 5437 9125  
[support.japan@freescale.com](mailto:support.japan@freescale.com)

### **Asia/Pacific:**

Freescale Semiconductor China Ltd.  
Exchange Building 23F  
No. 118 Jianguo Road  
Chaoyang District  
Beijing 100022  
China  
+86 10 5879 8000  
[support.asia@freescale.com](mailto:support.asia@freescale.com)

### **For Literature Requests Only:**

Freescale Semiconductor Literature Distribution Center  
P.O. Box 5405  
Denver, Colorado 80217  
1-800-441-2447 or +1-303-675-2140  
Fax: +1-303-675-2150  
[LDCForFreescaleSemiconductor@hibbertgroup.com](mailto:LDCForFreescaleSemiconductor@hibbertgroup.com)

Information in this document is provided solely to enable system and software implementers to use Freescale Semiconductor products. There are no express or implied copyright licenses granted hereunder to design or fabricate any integrated circuits or integrated circuits based on the information in this document.

Freescale Semiconductor reserves the right to make changes without further notice to any products herein. Freescale Semiconductor makes no warranty, representation or guarantee regarding the suitability of its products for any particular purpose, nor does Freescale Semiconductor assume any liability arising out of the application or use of any product or circuit, and specifically disclaims any and all liability, including without limitation consequential or incidental damages. "Typical" parameters that may be provided in Freescale Semiconductor data sheets and/or specifications can and do vary in different applications and actual performance may vary over time. All operating parameters, including "Typicals", must be validated for each customer application by customer's technical experts. Freescale Semiconductor does not convey any license under its patent rights nor the rights of others. Freescale Semiconductor products are not designed, intended, or authorized for use as components in systems intended for surgical implant into the body, or other applications intended to support or sustain life, or for any other application in which the failure of the Freescale Semiconductor product could create a situation where personal injury or death may occur. Should Buyer purchase or use Freescale Semiconductor products for any such unintended or unauthorized application, Buyer shall indemnify and hold Freescale Semiconductor and its officers, employees, subsidiaries, affiliates, and distributors harmless against all claims, costs, damages, and expenses, and reasonable attorney fees arising out of, directly or indirectly, any claim of personal injury or death associated with such unintended or unauthorized use, even if such claim alleges that Freescale Semiconductor was negligent regarding the design or manufacture of the part.

Freescale™ and the Freescale logo are trademarks of Freescale Semiconductor, Inc. All other product or service names are the property of their respective owners.

© Freescale Semiconductor, Inc. 2006-2008. All rights reserved.

## Looking for pricing, stock, or lifecycle information?

Click below to explore more details on WIN SOURCE:

- ⊖ [View MRF6S27015GNR1 on WIN SOURCE](#)
- ⊖ [Freescale Semiconductor - NXP Information](#)

## Optimize Your Supply Chain with WIN SOURCE Solutions

- ✓ Global Sourcing Solution
- ✓ Obsolete Management
- ✓ Cost Control Management
- ✓ Shortage Management
- ✓ Alternative Solution
- ✓ Excess Inventory Management