



**THE DATASHEET OF
MRF8P20140WHSR5**



RF Power Field Effect Transistors

N-Channel Enhancement-Mode Lateral MOSFETs

Designed for CDMA base station applications with frequencies from 1880 to 2025 MHz. Can be used in Class AB and Class C for all typical cellular base station modulation formats.

- Typical Doherty Single-Carrier W-CDMA Performance: $V_{DD} = 28$ Volts, $I_{DQA} = 500$ mA, $V_{GSB} = 1.2$ Vdc, $P_{out} = 24$ Watts Avg., IQ Magnitude Clipping, Channel Bandwidth = 3.84 MHz, Input Signal PAR = 9.9 dB @ 0.01% Probability on CCDF.

Frequency	G_{ps} (dB)	η_D (%)	Output PAR (dB)	ACPR (dBc)
1880 MHz	16.0	42.8	8.0	-31.0
1920 MHz	16.0	43.7	8.1	-32.6
2025 MHz	15.9	42.0	8.1	-31.2

- Capable of Handling 10:1 VSWR, @ 30 Vdc, 1920 MHz, 160 Watts CW (1) Output Power (3 dB Input Overdrive from Rated P_{out})
- Typical P_{out} @ 3 dB Compression Point ≈ 170 Watts (1)

Features

- Designed for Wide Instantaneous Bandwidth Applications. $VBW_{res} \approx 240$ MHz.
- Designed for Wideband Applications that Require 160 MHz Signal Bandwidth
- Production Tested in a Symmetrical Doherty Configuration
- 100% PAR Tested for Guaranteed Output Power Capability
- Characterized with Large-Signal Load-Pull Parameters and Common Source S-Parameters
- Internally Matched for Ease of Use
- Integrated ESD Protection
- Greater Negative Gate-Source Voltage Range for Improved Class C Operation
- Designed for Digital Predistortion Error Correction Systems
- NI-780H-4L in Tape and Reel. R3 Suffix = 250 Units, 56 mm Tape Width, 13-inch Reel.
- NI-780S-4L, NI-780GS-4L in Tape and Reel. R3 Suffix = 250 Units, 32 mm Tape Width, 13-inch Reel.

MRF8P20140WHR3
MRF8P20140WHSR3
MRF8P20140WGHSR3

1880-2025 MHz, 24 W AVG., 28 V
SINGLE W-CDMA
LATERAL N-CHANNEL
RF POWER MOSFETs

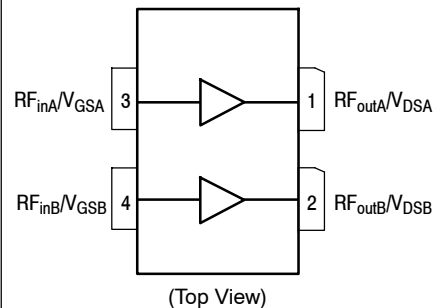
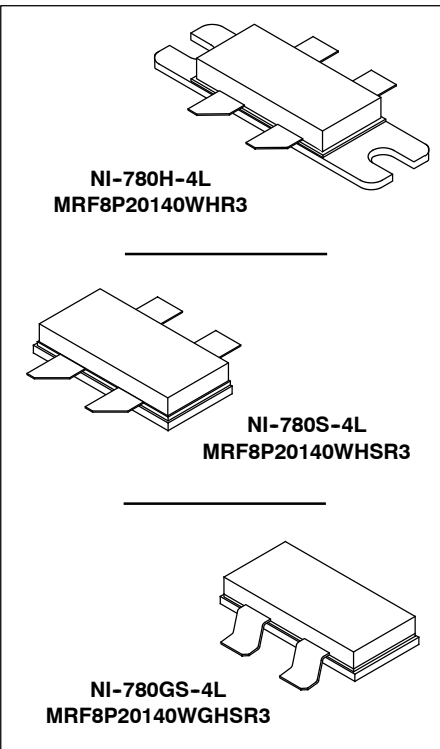

Figure 1. Pin Connections

1. $P_{3dB} = P_{avg} + 7.0$ dB where P_{avg} is the average output power measured using an unclipped W-CDMA single-carrier input signal where output PAR is compressed to 7.0 dB @ 0.01% probability on CCDF.

Table 1. Maximum Ratings

Rating	Symbol	Value	Unit
Drain-Source Voltage	V_{DSS}	-0.5, +65	Vdc
Gate-Source Voltage	V_{GS}	-6.0, +10	Vdc
Operating Voltage	V_{DD}	32, +0	Vdc
Storage Temperature Range	T_{stg}	-65 to +150	°C
Case Operating Temperature	T_C	125	°C
Operating Junction Temperature (1,2)	T_J	225	°C
CW Operation @ $T_C = 25^\circ\text{C}$ Derate above 25°C	CW	140 0.66	W W/°C

Table 2. Thermal Characteristics

Characteristic	Symbol	Value (2,3)	Unit
Thermal Resistance, Junction to Case Case Temperature 80°C , 24 W CW, 28 Vdc, $I_{DQA} = 500\text{ mA}$, $V_{GSB} = 1.2\text{ Vdc}$, 1920 MHz Case Temperature 96°C , 130 W CW (3), 28 Vdc, $I_{DQA} = 500\text{ mA}$, $V_{GSB} = 1.2\text{ Vdc}$, 1920 MHz	$R_{\theta JC}$	0.68 0.40	°C/W

Table 3. ESD Protection Characteristics

Test Methodology	Class
Human Body Model (per JESD22-A114)	2
Machine Model (per EIA/JESD22-A115)	A
Charge Device Model (per JESD22-C101)	IV

Table 4. Electrical Characteristics ($T_A = 25^\circ\text{C}$ unless otherwise noted)

Characteristic	Symbol	Min	Typ	Max	Unit
----------------	--------	-----	-----	-----	------

Off Characteristics (4)

Zero Gate Voltage Drain Leakage Current ($V_{DS} = 65\text{ Vdc}$, $V_{GS} = 0\text{ Vdc}$)	I_{DSS}	—	—	10	μAdc
Zero Gate Voltage Drain Leakage Current ($V_{DS} = 28\text{ Vdc}$, $V_{GS} = 0\text{ Vdc}$)	I_{DSS}	—	—	5	μAdc
Gate-Source Leakage Current ($V_{GS} = 5\text{ Vdc}$, $V_{DS} = 0\text{ Vdc}$)	I_{GSS}	—	—	1	μAdc

On Characteristics (4,5)

Gate Threshold Voltage ($V_{DS} = 10\text{ Vdc}$, $I_D = 200\ \mu\text{Adc}$)	$V_{GS(th)}$	1.1	1.8	2.6	Vdc
Gate Quiescent Voltage ($V_{DS} = 28\text{ Vdc}$, $I_{DA} = 500\text{ mAdc}$)	$V_{GSA(Q)}$	—	2.6	—	Vdc
Fixture Gate Quiescent Voltage (6) ($V_{DD} = 28\text{ Vdc}$, $I_{DA} = 500\text{ mAdc}$, Measured in Functional Test)	$V_{GGA(Q)}$	4.5	5.2	6.0	Vdc
Drain-Source On-Voltage ($V_{GS} = 10\text{ Vdc}$, $I_D = 2\text{ Adc}$)	$V_{DS(on)}$	0.1	0.2	0.3	Vdc

1. Continuous use at maximum temperature will affect MTTF.
2. MTTF calculator available at <http://www.freescale.com/rf>. Select Software & Tools/Development Tools/Calculators to access MTTF calculators by product.
3. Refer to AN1955, *Thermal Measurement Methodology of RF Power Amplifiers*. Go to <http://www.freescale.com/rf>. Select Documentation/Application Notes – AN1955.
4. Exceeds recommended operating conditions. See CW operation data in Maximum Ratings table.
5. Each side of device measured separately.
6. V_{DDA} and V_{ddb} must be tied together and powered by a single DC power supply.
7. $V_{GG} = 2.0 \times V_{GS(Q)}$. Parameter measured on Freescale Test Fixture, due to resistive divider network on the board. Refer to Test Circuit schematic. (continued)

Table 4. Electrical Characteristics ($T_A = 25^\circ\text{C}$ unless otherwise noted) (continued)

Characteristic	Symbol	Min	Typ	Max	Unit
Functional Tests (1,2,3,4) (In Freescale Doherty Test Fixture, 50 ohm system) $V_{DD} = 28\text{ Vdc}$, $I_{DQA} = 500\text{ mA}$, $V_{GSB} = 1.2\text{ Vdc}$, $P_{out} = 24\text{ W Avg.}$, $f_1 = 1880\text{ MHz}$, $f_2 = 1910\text{ MHz}$, 2-Carrier W-CDMA, IQ Magnitude Clipping, Input Signal PAR = 9.8 dB @ 0.01% Probability on CCDF. ACPR measured in 3.84 MHz Channel Bandwidth @ $\pm 5\text{ MHz}$ Offset.					
Power Gain	G_{ps}	15.0	16.0	18.0	dB
Drain Efficiency	η_D	37.5	41.2	—	%
Output Peak-to-Average Ratio @ 0.01% Probability on CCDF	PAR	7.3	7.7	—	dB
Adjacent Channel Power Ratio	ACPR	—	-31.9	-29.5	dBc

Typical Performance over Frequency (3) — (In Freescale Doherty Test Fixture, 50 ohm system) $V_{DD} = 28\text{ Vdc}$, $I_{DQA} = 500\text{ mA}$, $V_{GSB} = 1.2\text{ Vdc}$, $P_{out} = 24\text{ W Avg.}$, Single-Carrier W-CDMA, IQ Magnitude Clipping, Input Signal PAR = 9.9 dB @ 0.01% Probability on CCDF. ACPR measured in 3.84 MHz Channel Bandwidth @ $\pm 5\text{ MHz}$ Offset.

Frequency	G_{ps} (dB)	η_D (%)	Output PAR (dB)	ACPR (dBc)
1880 MHz	16.0	42.8	8.0	-31.0
1920 MHz	16.0	43.7	8.1	-32.6
2025 MHz	15.9	42.0	8.1	-31.2

Typical Performances (3) (In Freescale Doherty Test Fixture, 50 ohm system) $V_{DD} = 28\text{ Vdc}$, $I_{DQA} = 500\text{ mA}$, $V_{GSB} = 1.2\text{ Vdc}$, 1880-2025 MHz Bandwidth

P_{out} @ 1 dB Compression Point, CW	P1dB	—	140	—	W
P_{out} @ 3 dB Compression Point (5)	P3dB	—	170	—	W
IMD Symmetry @ 24 W PEP, P_{out} where IMD Third Order Intermodulation $\cong 30\text{ dBc}$ (Delta IMD Third Order Intermodulation between Upper and Lower Sidebands > 2 dB)	IMD _{sym}	—	133	—	MHz
VBW Resonance Point (IMD Third Order Intermodulation Inflection Point)	VBW _{res}	—	240	—	MHz
Gain Flatness in 145 MHz Bandwidth @ $P_{out} = 24\text{ W Avg.}$	G_F	—	0.25	—	dB
Gain Variation over Temperature (-30°C to +85°C)	ΔG	—	0.013	—	dB/°C
Output Power Variation over Temperature (-30°C to +85°C) (6)	ΔP_{1dB}	—	0.003	—	dB/°C

1. V_{DDA} and V_{DDB} must be tied together and powered by a single DC power supply.
2. Part internally matched both on input and output.
3. Measurement made with device in a Symmetrical Doherty configuration.
4. Measurement made with device in straight lead configuration before any lead forming operation is applied. Lead forming is used for gull wing (GHS) parts.
5. $P_{3dB} = P_{avg} + 7.0\text{ dB}$ where P_{avg} is the average output power measured using an unclipped W-CDMA single-carrier input signal where output PAR is compressed to 7.0 dB @ 0.01% probability on CCDF.

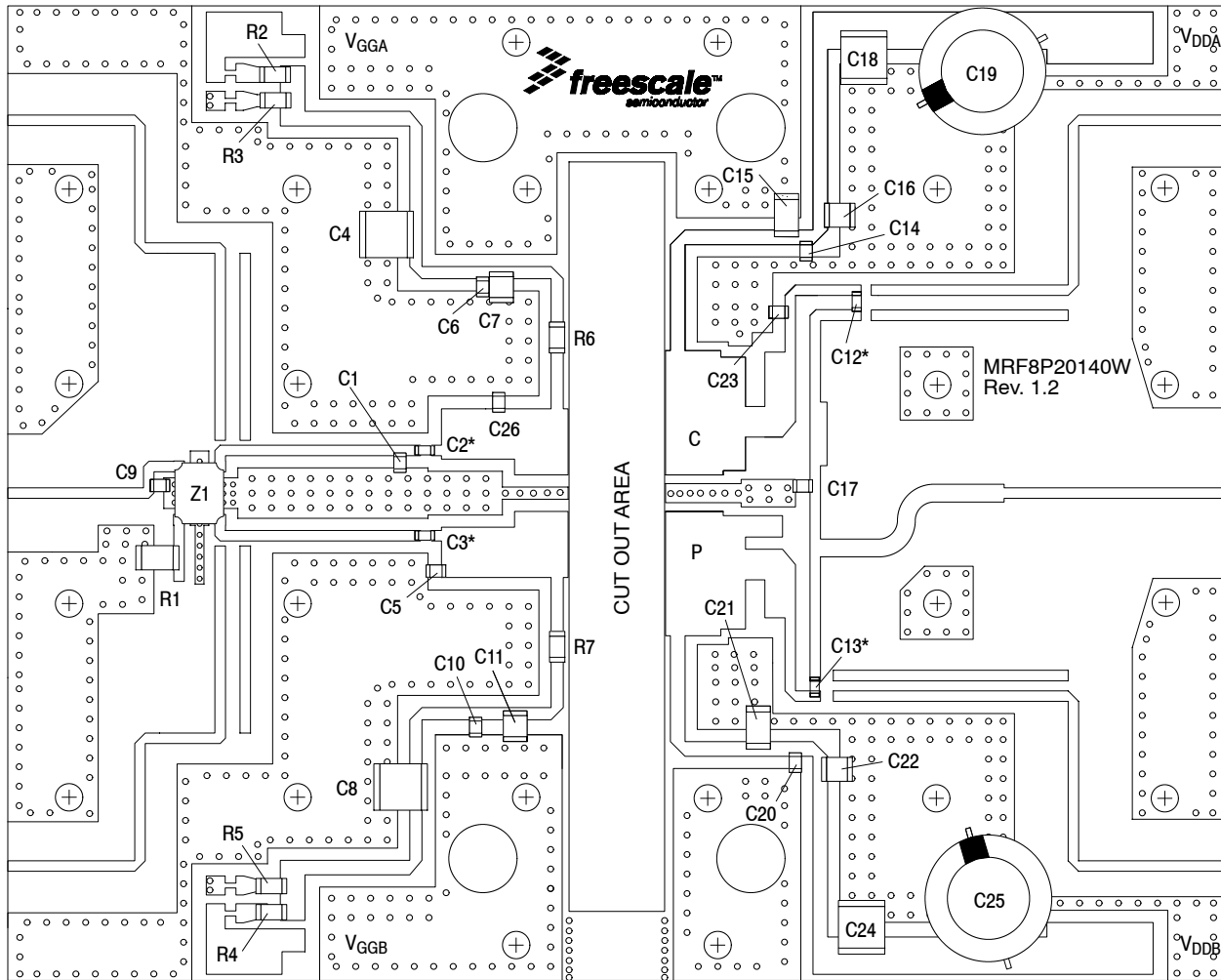

Note 1: * denotes that C2, C3, C12 and C13 are mounted vertically.

Note 2: V_{DDA} and V_{ddb} must be tied together and powered by a single DC power supply.

Figure 2. MRF8P20140WHR3(WHSR3) Test Circuit Component Layout

Table 5. MRF8P20140WHR3(WHSR3) Test Circuit Component Designations and Values

Part	Description	Part Number	Manufacturer
C1	0.6 pF Chip Capacitor	ATC600F0R6BT250XT	ATC
C2, C3	8.2 pF Chip Capacitors	ATC600F8R2BT250XT	ATC
C4, C8, C18, C24	10 μ F, 50 V Chip Capacitors	GRM55DR61H106KA88L	Murata
C5	1.2 pF Chip Capacitor	ATC600F1R2BT250XT	ATC
C6, C10, C12, C13, C14, C20	12 pF Chip Capacitors	ATC600F120JT250XT	ATC
C7, C11	10 μ F, 32 V Chip Capacitors	GRM32ER61H106KA12L	Murata
C9, C17	0.1 pF Chip Capacitors	ATC600F0R1BT250XT	ATC
C15, C21	6.8 μ F, 50 V Chip Capacitors	C4532X7R1H685KT	TDK
C16, C22	2.2 μ F, 100 V Chip Capacitors	C3225X7R2A225KT	TDK
C19, C25	220 μ F, 100 V Chip Capacitors	EEV-FK2A221M	Panasonic-ECG
C23	0.2 pF Chip Capacitor	ATC600F0R2BT250XT	ATC
C26	1.5 pF Chip Capacitor	ATC600F1R5BT250XT	ATC
R1	50 Ω , Chip Resistor	ATCCW12010T0050GBK	ATC
R2, R3, R4, R5	1.5 k Ω , 1/4 W Chip Resistors	CRCW12061K50FKEA	Vishay
R6, R7	2.2 Ω , 1/4 W Chip Resistors	CRCW12062R2FNEA	Vishay
Z1	1700-2000 MHz Band 90°, 3 dB Hybrid Coupler	1P503S	Anaren
PCB	0.020", $\epsilon_r = 3.5$	R04350B	Rogers

MRF8P20140WHR3 MRF8P20140WHSR3 MRF8P20140WGHSR3

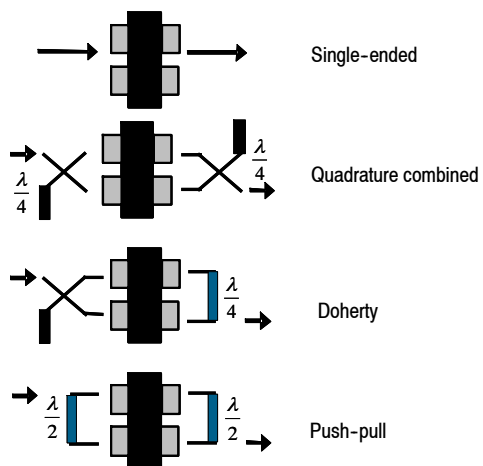

Figure 3. Possible Circuit Topologies

TYPICAL CHARACTERISTICS

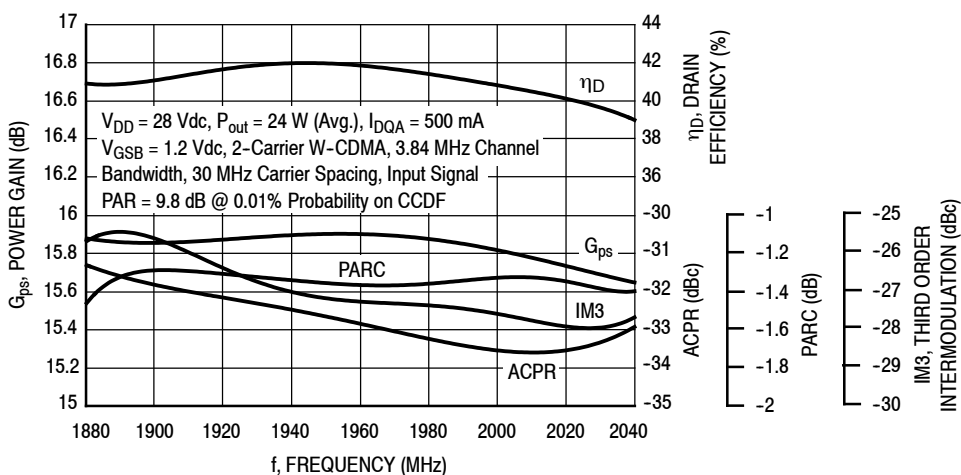

Figure 4. 2-Carrier Output Peak-to-Average Ratio Compression (PARC) Broadband Performance @ $P_{out} = 24$ Watts Avg.

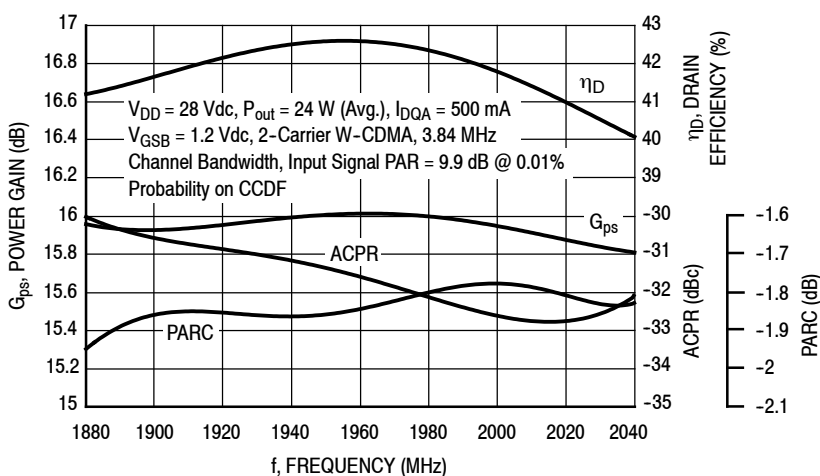

Figure 5. Single-Carrier Output Peak-to-Average Ratio Compression (PARC) Broadband Performance @ $P_{out} = 24$ Watts Avg.

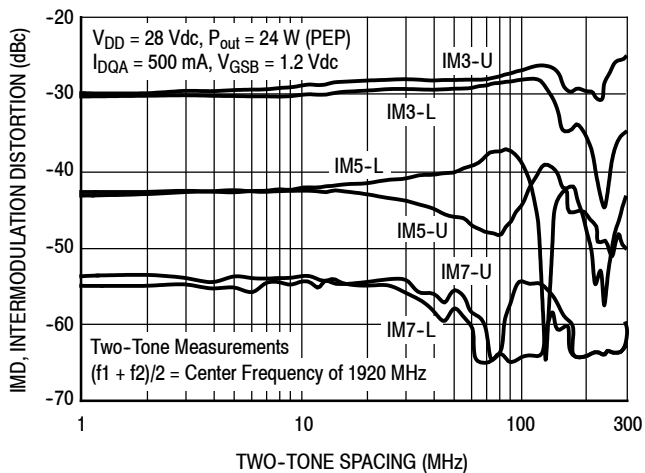

Figure 6. Intermodulation Distortion Products versus Two-Tone Spacing

TYPICAL CHARACTERISTICS

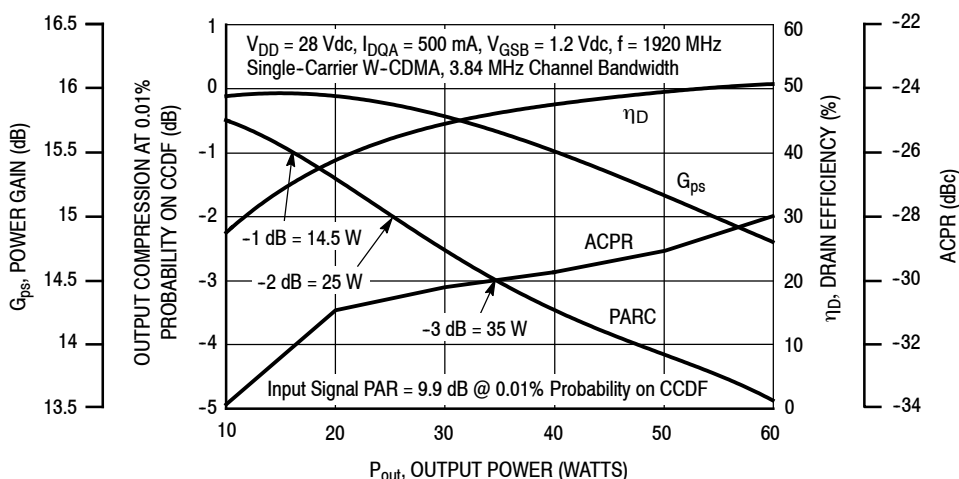

Figure 7. Output Peak-to-Average Ratio Compression (PARC) versus Output Power

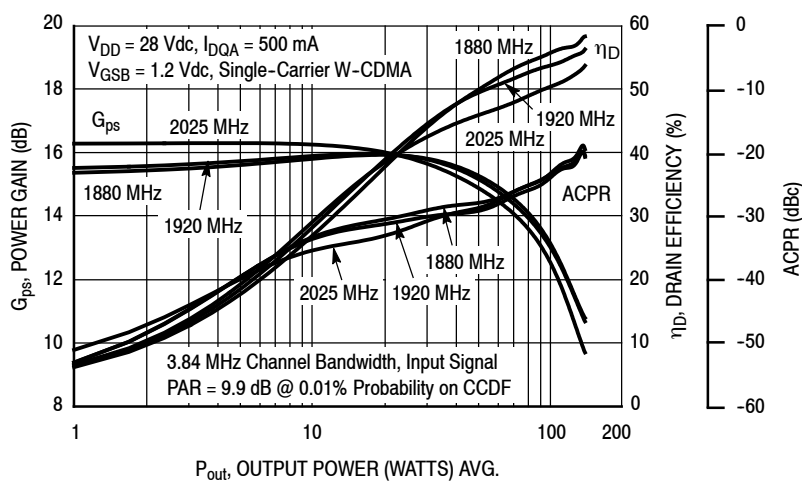

Figure 8. Single-Carrier W-CDMA Power Gain, Drain Efficiency and ACPR versus Output Power

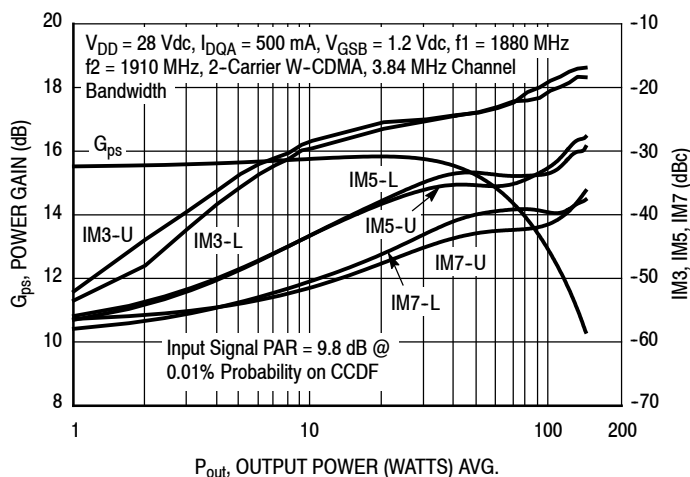

Figure 9. 2-Carrier W-CDMA Power Gain, IM3, IM5, IM7 versus Output Power

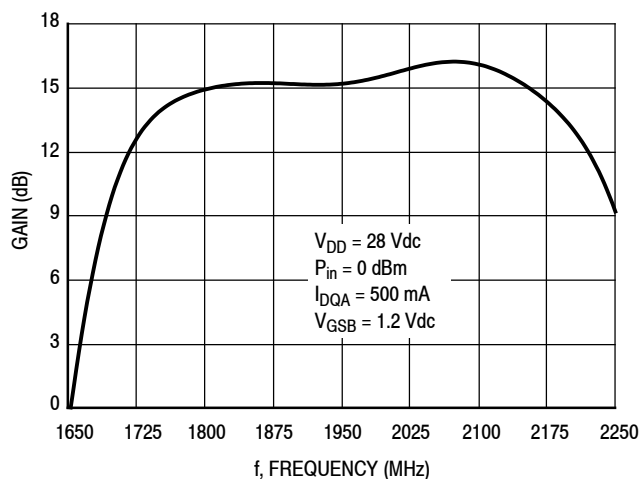

Figure 10. Broadband Frequency Response

W-CDMA TEST SIGNAL

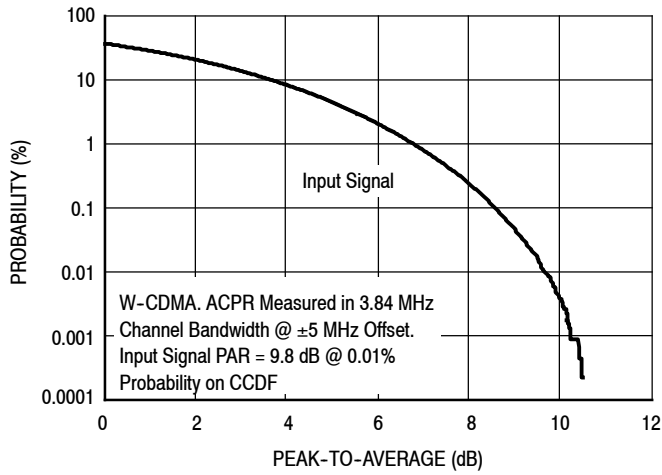

Figure 11. CCDF W-CDMA IQ Magnitude Clipping, 2-Carrier Test Signal

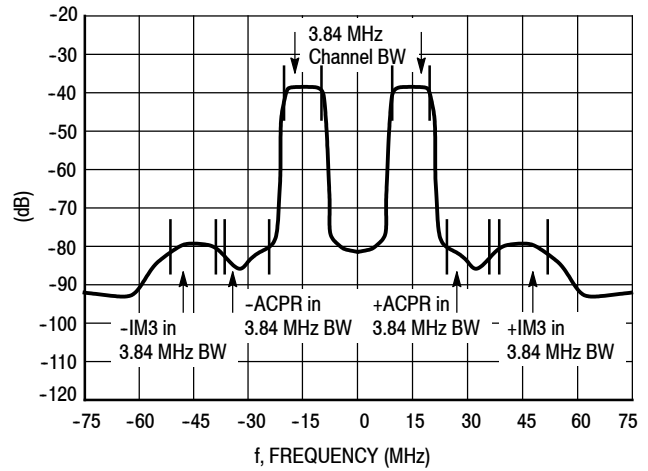

Figure 12. 2-Carrier W-CDMA Spectrum

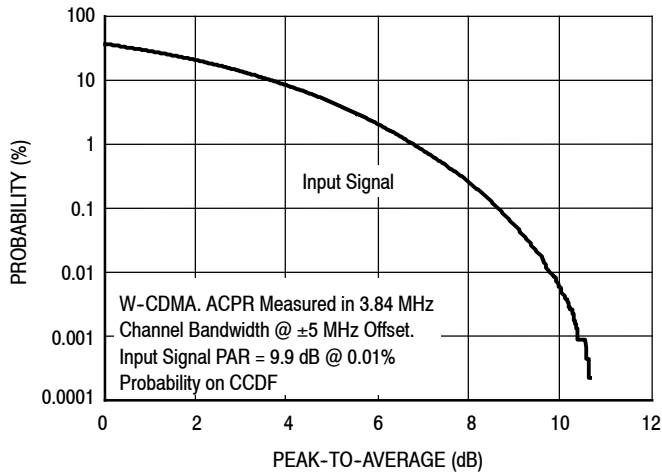

Figure 13. CCDF W-CDMA IQ Magnitude Clipping, Single-Carrier Test Signal

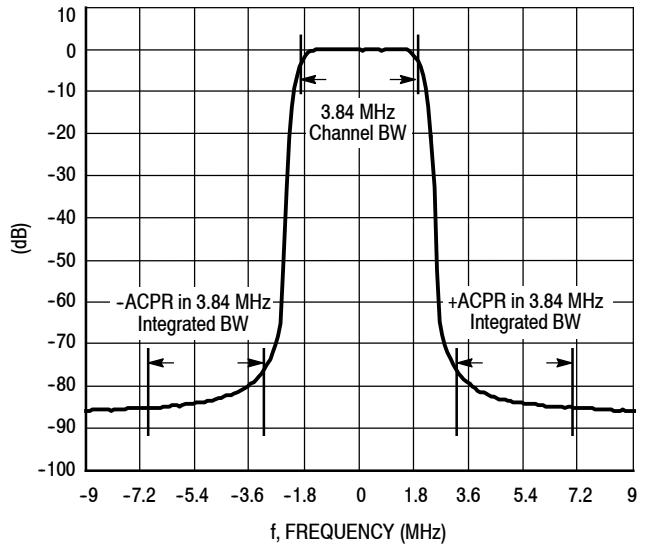

Figure 14. Single-Carrier W-CDMA Spectrum

$V_{DD} = 28 \text{ Vdc}$, $I_{DQA} = 500 \text{ mA}$, Pulsed CW, 10 μsec (on), 10% Duty Cycle

f (MHz)	Z_{source} (Ω)	$Z_{\text{load}}^{(1)}$ (Ω)	Max Output Power					
			P1dB			P3dB		
			(dBm)	(W)	η_D (%)	(dBm)	(W)	η_D (%)
1880	5.35 - j5.03	2.36 - j4.84	49.7	93	53.7	50.5	113	56.2
1930	7.39 - j5.10	2.57 - j4.73	50.0	100	56.9	50.8	119	59.3
1990	9.46 - j1.71	2.48 - j5.11	50.0	100	56.4	50.7	118	58.6
2025	9.30 + j0.80	2.50 - j5.30	50.0	100	56.7	50.7	118	59.1

(1) Load impedance for optimum P1dB power.

Z_{source} = Impedance as measured from gate contact to ground.

Z_{load} = Impedance as measured from drain contact to ground.

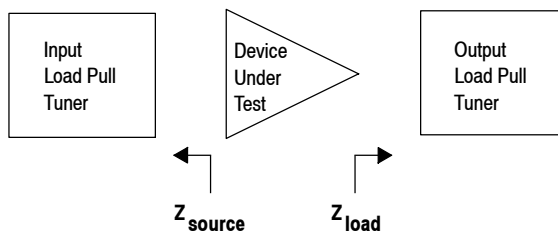

Figure 15. Carrier Side Load Pull Performance — Maximum P1dB Tuning

$V_{DD} = 28 \text{ Vdc}$, $I_{DQA} = 500 \text{ mA}$, Pulsed CW, 10 μsec (on), 10% Duty Cycle

f (MHz)	Z_{source} (Ω)	$Z_{\text{load}}^{(1)}$ (Ω)	Max Drain Efficiency					
			P1dB			P3dB		
			(dBm)	(W)	η_D (%)	(dBm)	(W)	η_D (%)
1880	5.35 - j5.03	6.91 - j4.37	47.6	57	64.6	48.2	67	65.2
1930	7.39 - j5.10	6.36 - j3.60	48.0	63	67.3	48.6	72	68.3
1990	9.46 - j1.71	5.61 - j3.11	48.0	63	67.2	48.6	72	67.8
2025	9.30 + j0.80	5.28 - j2.88	47.9	61	66.5	48.5	70	67.3

(1) Load impedance for optimum P1dB efficiency.

Z_{source} = Impedance as measured from gate contact to ground.

Z_{load} = Impedance as measured from drain contact to ground.

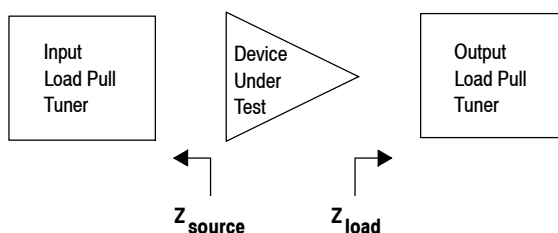
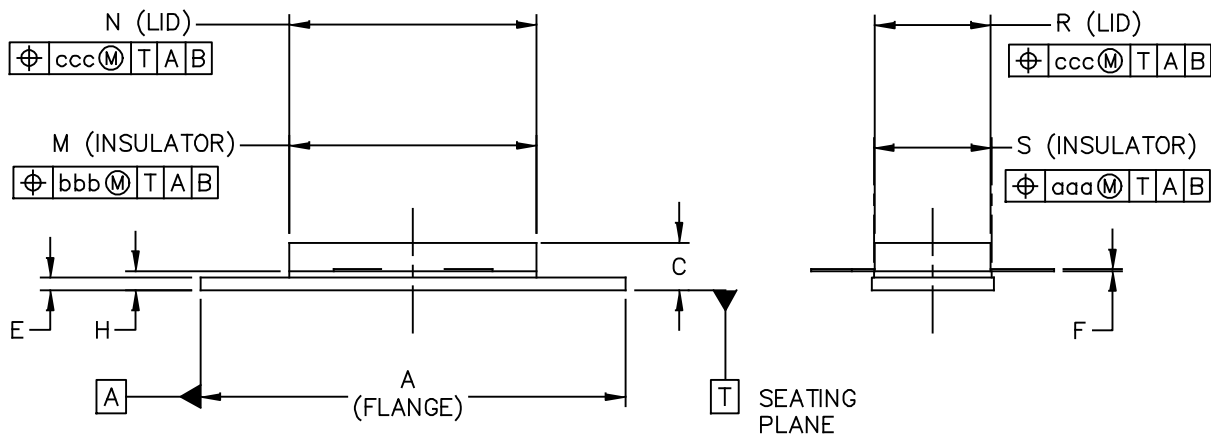
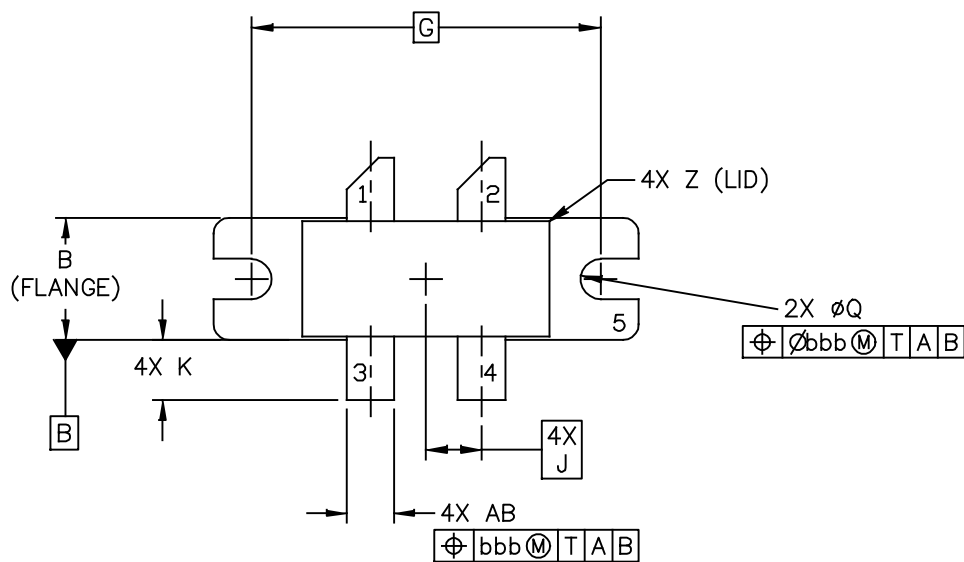

Figure 16. Carrier Side Load Pull Performance — Maximum Efficiency Tuning

PACKAGE DIMENSIONS



© FREESCALE SEMICONDUCTOR, INC. ALL RIGHTS RESERVED.	MECHANICAL OUTLINE	PRINT VERSION NOT TO SCALE
TITLE: NI 780-4	DOCUMENT NO: 98ASA10793D	REV: 0
	CASE NUMBER: 465M-01	27 MAR 2007
	STANDARD: NON-JEDEC	

NOTES:

1. DIMENSIONING AND TOLERANCING PER ANSI Y14.5M-1994.
2. CONTROLLING DIMENSION: INCH.
3. DIMENSION H IS MEASURED .030 (0.762) AWAY FROM PACKAGE BODY.

STYLE 1:

- PIN 1. DRAIN
 2. DRAIN
 3. GATE
 4. GATE
 5. SOURCE

DIM	INCH		MILLIMETER		DIM	INCH		MILLIMETER	
	MIN	MAX	MIN	MAX		MIN	MAX	MIN	MAX
A	1.335	1.345	33.91	34.16	R	.365	.375	9.27	9.53
B	.380	.390	9.65	9.91	S	.365	.375	9.27	9.52
C	.125	.170	3.18	4.32	U		.040		1.02
E	.035	.045	0.89	1.14	Z		.030		0.76
F	.003	.006	0.08	0.15	AB	.145	.155	3.68	3.94
G	1.100 BSC		27.94 BSC						
H	.057	.067	1.45	1.7	aaa		.005		0.127
J	.175 BSC		4.44 BSC		bbb		.010		0.254
K	.170	.210	4.32	5.33	ccc		.015		0.381
M	.774	.786	19.61	20.02					
N	.772	.788	19.61	20.02					
Q	∅.118	∅.138	∅3	∅3.51					
© FREESCALE SEMICONDUCTOR, INC. ALL RIGHTS RESERVED.			MECHANICAL OUTLINE			PRINT VERSION NOT TO SCALE			
TITLE: NI 780-4					DOCUMENT NO: 98ASA10793D			REV: 0	
					CASE NUMBER: 465M-01			27 MAR 2007	
					STANDARD: NON-JEDEC				

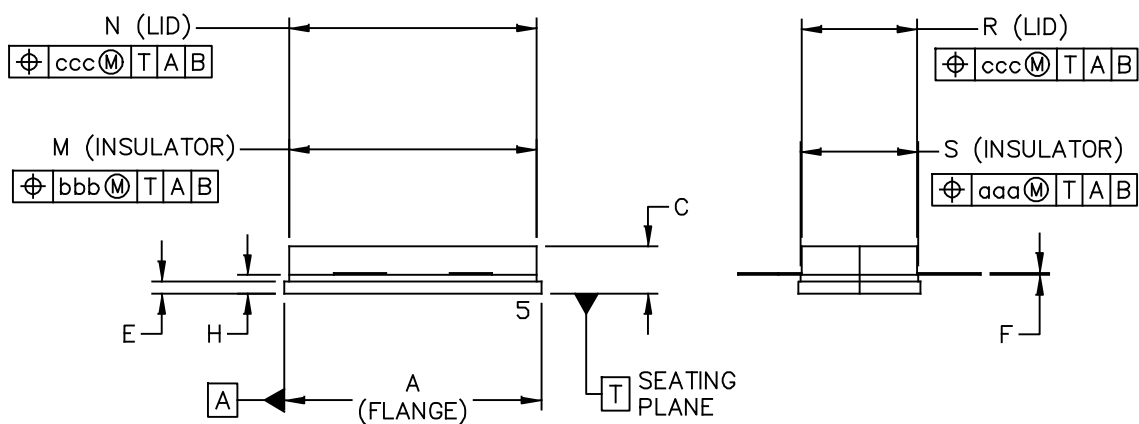
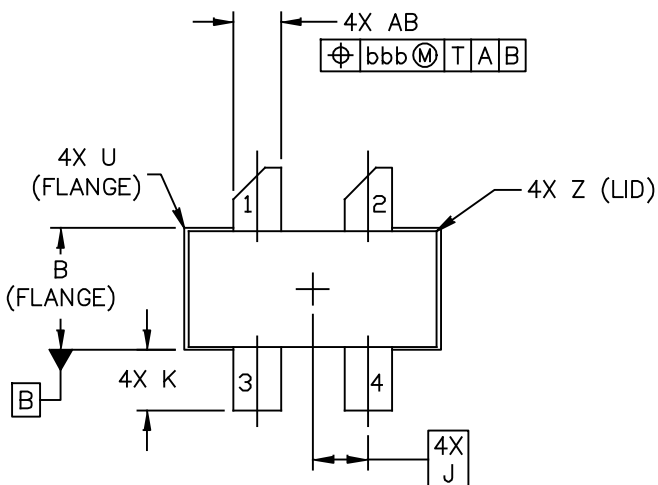

© FREESCALE SEMICONDUCTOR, INC. ALL RIGHTS RESERVED.	MECHANICAL OUTLINE	PRINT VERSION NOT TO SCALE	
TITLE: NI 780S-4	DOCUMENT NO: 98ASA10718D	REV: A	
	CASE NUMBER: 465H-02	27 MAR 2007	
	STANDARD: NON-JEDEC		

NOTES:

1. DIMENSIONING AND TOLERANCING PER ANSI Y14.5M-1994.
2. CONTROLLING DIMENSION: INCH.
3. DELETED
4. DIMENSION H IS MEASURED .030 (0.762) AWAY FROM PACKAGE BODY.

STYLE 1:

- PIN 1. DRAIN
- 2. DRAIN
- 3. GATE
- 4. GATE
- 5. SOURCE

DIM	INCH		MILLIMETER		DIM	INCH		MILLIMETER	
	MIN	MAX	MIN	MAX		MIN	MAX	MIN	MAX
A	.805	.815	20.45	20.7	U		.040		1.02
B	.380	.390	9.65	9.91	Z		.030		0.76
C	.125	.170	3.18	4.32	AB	.145	.155	3.68	– 3.94
E	.035	.045	0.89	1.14					
F	.003	.006	0.08	0.15	aaa		.005		0.127
H	.057	.067	1.45	1.7	bbb		.010		0.254
J	.175 BSC		4.44 BSC		ccc		.015		0.381
K	.170	.210	4.32	5.33					
M	.774	.786	19.61	20.02					
N	.772	.788	19.61	20.02					
R	.365	.375	9.27	9.53					
S	.365	.375	9.27	9.52					
© FREESCALE SEMICONDUCTOR, INC. ALL RIGHTS RESERVED.			MECHANICAL OUTLINE			PRINT VERSION NOT TO SCALE			
TITLE: NI 780S-4					DOCUMENT NO: 98ASA10718D			REV: A	
					CASE NUMBER: 465H-02			27 MAR 2007	
					STANDARD: NON-JEDEC				

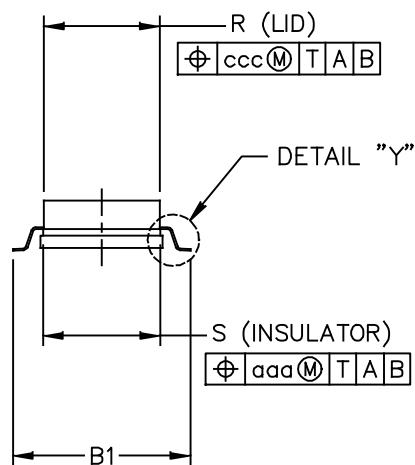
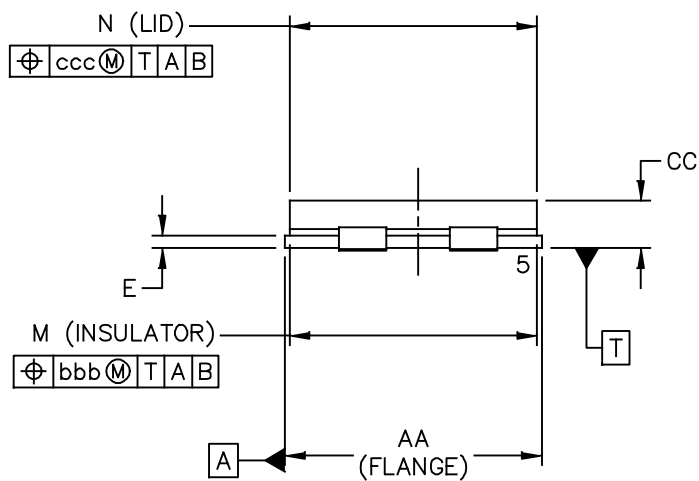
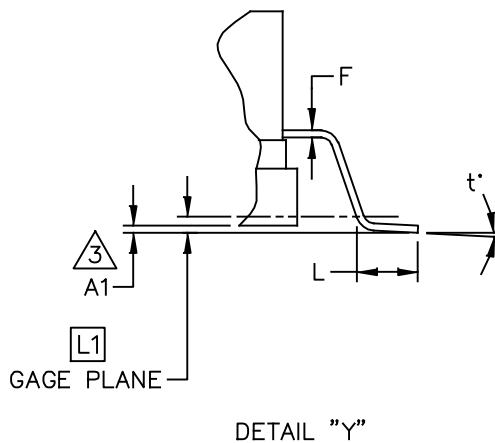
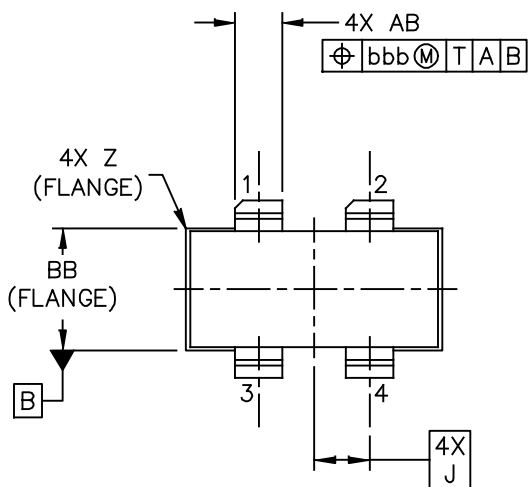

© FREESCALE SEMICONDUCTOR, INC. ALL RIGHTS RESERVED.	MECHANICAL OUTLINE	PRINT VERSION NOT TO SCALE
TITLE: NI-780GS-4L	DOCUMENT NO: 98ASA00238D	REV: B
	STANDARD: NON-JEDEC	
		05 SEP 2013

NOTES:

1. DIMENSIONING AND TOLERANCING PER ANSI Y14.5M-1994.
2. CONTROLLING DIMENSION: INCH.

3. DIMENSION A1 IS MEASURED WITH REFERENCE TO DATUM T. THE POSITIVE VALUE IMPLIES THAT THE PACKAGE BOTTOM IS HIGHER THAN THE LEAD BOTTOM.

DIM	INCH		MILLIMETER		DIM	INCH		MILLIMETER	
	MIN	MAX	MIN	MAX		MIN	MAX	MIN	MAX
AA	.805	.815	20.45	20.70	Z	R.000	R.040	R0.00	R1.02
A1	.002	.008	0.05	0.20	AB	.145	.155	3.68	3.94
BB	.380	.390	9.65	9.91	t°	0°	8°	0°	8°
B1	.546	.562	13.87	14.27	aaa		.005		0.13
CC	.125	.170	3.18	4.32	bbb		.010		0.25
E	.035	.045	0.89	1.14	ccc		.015		0.38
F	.003	.006	0.08	0.15					
L	.038	.046	0.97	1.17					
L1	.010 BSC		0.25 BSC						
J	.175 BSC		4.44 BSC						
M	.774	.786	19.66	19.96					
N	.772	.788	19.61	20.02					
R	.365	.375	9.27	9.53					
S	.365	.375	9.27	9.53					

© FREESCALE SEMICONDUCTOR, INC. ALL RIGHTS RESERVED.		MECHANICAL OUTLINE	PRINT VERSION NOT TO SCALE
TITLE:		DOCUMENT NO: 98ASA00238D	REV: B
NI-780GS-4L		STANDARD: NON-JEDEC	
		05 SEP 2013	

PRODUCT DOCUMENTATION, SOFTWARE AND TOOLS

Refer to the following documents, Software and Tools to aid your design process.

Application Notes

- AN1955: Thermal Measurement Methodology of RF Power Amplifiers

Engineering Bulletins

- EB212: Using Data Sheet Impedances for RF LDMOS Devices

Software

- Electromigration MTTF Calculator
- RF High Power Model
- .s2p File

For Software and Tools, do a Part Number search at <http://www.freescale.com>, and select the “Part Number” link. Go to the Software & Tools tab on the part’s Product Summary page to download the respective tool.

REVISION HISTORY

The following table summarizes revisions to this document.

Revision	Date	Description
0	Apr. 2011	<ul style="list-style-type: none"> • Initial Release of Data Sheet
1	Nov. 2013	<ul style="list-style-type: none"> • Added part number MRF8P20140WGHSR3 (NI-780GS-4L), p. 1 • Table 3, ESD Protection Characteristics, removed the word “Minimum” after the ESD class rating. ESD ratings are characterized during new product development but are not 100% tested during production. ESD ratings provided in the data sheet are intended to be used as a guideline when handling ESD sensitive devices, p. 2 • Added NI-780GS-4L package isometric, p. 1, and Mechanical Outline, pp. 14-15 • Added Electromigration MTTF Calculator and RF High Power Model availability to Product Software, p. 16

How to Reach Us:

Home Page:
freescale.com

Web Support:
freescale.com/support

Information in this document is provided solely to enable system and software implementers to use Freescale products. There are no express or implied copyright licenses granted hereunder to design or fabricate any integrated circuits based on the information in this document.

Freescale reserves the right to make changes without further notice to any products herein. Freescale makes no warranty, representation, or guarantee regarding the suitability of its products for any particular purpose, nor does Freescale assume any liability arising out of the application or use of any product or circuit, and specifically disclaims any and all liability, including without limitation consequential or incidental damages. "Typical" parameters that may be provided in Freescale data sheets and/or specifications can and do vary in different applications, and actual performance may vary over time. All operating parameters, including "typicals," must be validated for each customer application by customer's technical experts. Freescale does not convey any license under its patent rights nor the rights of others. Freescale sells products pursuant to standard terms and conditions of sale, which can be found at the following address: freescale.com/SalesTermsandConditions.

Freescale and the Freescale logo are trademarks of Freescale Semiconductor, Inc., Reg. U.S. Pat. & Tm. Off. All other product or service names are the property of their respective owners.

© 2013 Freescale Semiconductor, Inc.

Looking for pricing, stock, or lifecycle information?

Click below to explore more details on WIN SOURCE:

- ⊖ [View MRF8P20140WHSR5 on WIN SOURCE](#)
- ⊖ [Freescale Semiconductor - NXP Information](#)

Optimize Your Supply Chain with WIN SOURCE Solutions

- ✓ Global Sourcing Solution
- ✓ Obsolete Management
- ✓ Cost Control Management
- ✓ Shortage Management
- ✓ Alternative Solution
- ✓ Excess Inventory Management