



# THE DATASHEET OF MRF904



# MRF904

## RF & MICROWAVE DISCRETE LOW POWER TRANSISTORS

### Features

- Silicon NPN, high Frequency, To-72 packaged, Transistor
- High Power Gain - GU(max): 11 dB (typ) @ f = 450 MHz  
7 dB (typ) @ f = 1 GHz
- Low Noise Figure  
NF = 1.5 dB (typ) @ f = 450 MHz
- High  $F_T$  - 4 GHz (typ) @  $I_C$  = 15 mAdc

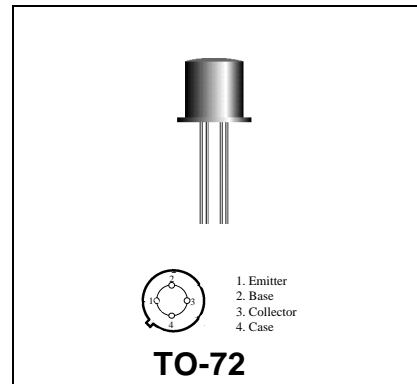

### DESCRIPTION:

Designed primarily for use in High Gain, low noise general-purpose amplifiers.

### ABSOLUTE MAXIMUM RATINGS ( $T_{case} = 25^{\circ}C$ )

Symbol	Parameter	Value	Unit
$V_{CEO}$	Collector-Emitter Voltage	15	Vdc
$V_{CBO}$	Collector-Base Voltage	25	Vdc
$V_{EBO}$	Emitter-Base Voltage	3.0	Vdc
$I_C$	Collector Current	30	mA

### Thermal Data

$P_D$	Total Device Dissipation @ $T_A = 25^{\circ}C$ Derate above $25^{\circ}C$	200 1.14	mWatts mW/ $^{\circ}C$
$T_{JMAX}$	Junction Temperature	200	$^{\circ}C$
$T_{STORAGE}$	Storage Temperature	-65 to +200	$^{\circ}C$

**ELECTRICAL SPECIFICATIONS (Tcase = 25°C)**
**STATIC  
(off)**

Symbol	Test Conditions	Value			Unit
		Min.	Typ.	Max.	
BVCEO	Collector-Emitter Breakdown Voltage (IC = 1.0 mAdc, IB = 0)	15	-	-	Vdc
BVCBO	Collector-Base Breakdown Voltage (IC = .1 mAdc, IE = 0)	25	-	-	Vdc
BVEBO	Emitter-Base Breakdown Voltage (IE = 0.1 mAdc, IC = 0)	3.0	-	-	Vdc
ICBO	Collector Cutoff Current (VCE = 15 Vdc, IE = 0 Vdc)	-	-	50	nA

**(on)**

HFE	DC Current Gain (IC = 5.0 mAdc, VCE = 5 Vdc)	30	-	200	-
-----	---	----	---	-----	---

**DYNAMIC**

Symbol	Test Conditions	Value			Unit
		Min.	Typ.	Max.	
f <sub>T</sub>	Current-Gain - Bandwidth Product (IC = 15 mAdc, VCE = 10 Vdc, f = 1 GHz)	-	4.0	-	GHz
CCB	Junction Capacitance (VCB = 10Vdc, IE=0, f=1 MHz)	-	-	1.5	pF
NF	Noise Figure (IC = 5.0 mAdc, VCE = 6.0 Vdc, f = 450 MHz)	-	1.5	-	dB

**Functional**

Symbol	Test Conditions	Value			Unit
		Min.	Typ.	Max.	
GU max	Maximum Unilateral Gain (1) (IC = 5.0 mAdc, VCE = 6.0 Vdc, f = 500 MHz) (IC = 5.0 mAdc, VCE = 6.0 Vdc, f = 1 GHz)	- -	11 7	- -	dB
$S_{ 21 ^2}$	Maximum Available Gain (1) (IC = 5.0 mAdc, VCE = 6.0 Vdc, f = 500 MHz) (IC = 5.0 mAdc, VCE = 6.0 Vdc, f = 1 GHz)	9.5 -	10.5 6.5	- -	dB
MAG	Maximum Available Gain (1) (IC = 5.0 mAdc, VCE = 6.0 Vdc, f = 500 MHz) (IC = 5.0 mAdc, VCE = 6.0 Vdc, f = 1 GHz)	- -	11 7	- -	dB

(1) Maximum Unilateral Gain =  $|S_{21}|^2 / (1 - |S_{11}|^2) (1 - |S_{22}|^2)$

Table 1. Common Emitter S-Parameters, @ VCE = 5 V, IC = 6 mA

f (MHz)	S11		S21		S12		S22	
	S11	$\angle \phi$	S21	$\angle \phi$	S12	$\angle \phi$	S22	$\angle \phi$
100	.66	-37	10.5	131	.040	71	.781	-23
200	.41	-52	7.03	111	.065	71	.597	-27
300	.31	-54	5.33	98	.093	70	.551	-26
400	.26	-59	4.00	90	.111	69	.517	-30
500	.20	-61	3.38	87	.136	71	.467	-30
600	.18	-59	3.00	81	.162	68	.455	-32
700	.16	-60	2.69	75	.186	66	.438	-36
800	.16	-66	2.30	70	.200	63	.437	-42
900	.15	-74	2.16	71	.215	65	.409	-47
1000	.15	-76	2.16	63	.243	62	.413	-48

**MRF904**

PACKAGE STYLE M244

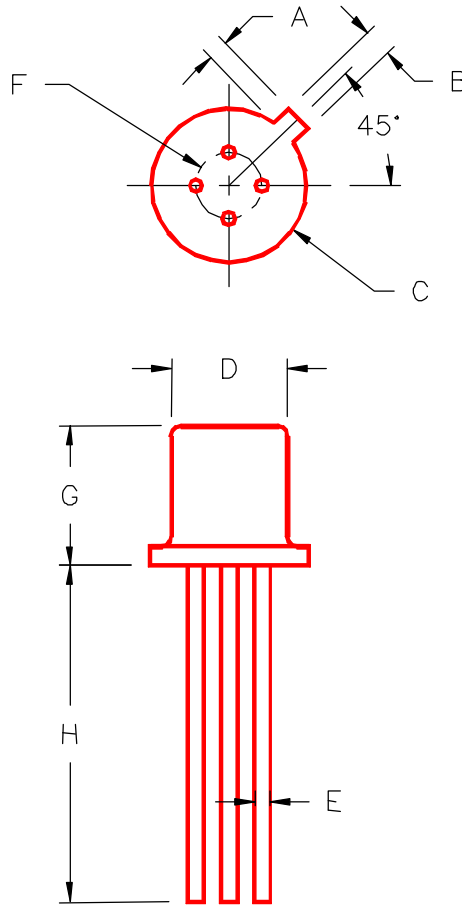

	MINIMUM INCHES/MM	MAXIMUM INCHES/MM		MINIMUM INCHES/MM	MAXIMUM INCHES/MM
A	.020/0,51	.048/1,22			
B	.036/0,91	.046/1,17			
C	.209/5,31	.230/5,84			
D	.178/4,52	.195/4,95			
E	.016/0,41	.020/0,51			
F	.100/2,54				
G	.170/4,32	.210/5,33			
H	.500/12,70				

## Looking for pricing, stock, or lifecycle information?

Click below to explore more details on WIN SOURCE:

- ⊖ [View MRF904 on WIN SOURCE](#)
- ⊖ [Microsemi Corporation](#) Information

## Optimize Your Supply Chain with WIN SOURCE Solutions

- ✓ Global Sourcing Solution
- ✓ Obsolete Management
- ✓ Cost Control Management
- ✓ Shortage Management
- ✓ Alternative Solution
- ✓ Excess Inventory Management