



**THE DATASHEET OF
MRFG35010MT1**



Replaced by MRFG35010NT1. There are no form, fit or function changes with this part replacement. N suffix added to part number to indicate transition to lead-free terminations.

MRFG35010MT1

Gallium Arsenide PHEMT RF Power Field Effect Transistor

Designed for WLL/MMDS/BWA or UMTS driver applications with frequencies from 1.8 to 3.6 GHz. This device is unmatched and is suitable for use in Class AB linear base station applications.

- Typical W-CDMA Performance: -42 dBc ACPR, 3.55 GHz, 12 Volts, $I_{DQ} = 180$ mA, 5 MHz Offset/3.84 MHz BW, 64 DPCH (8.5 dB P/A @ 0.01% Probability)
 - Output Power — 900 mW
 - Power Gain — 10 dB
 - Efficiency — 28%
- 9 Watts P1dB @ 3.55 GHz
- Excellent Phase Linearity and Group Delay Characteristics
- High Gain, High Efficiency and High Linearity
- In Tape and Reel. T1 Suffix = 1000 Units per 12 mm, 7 inch Reel.

**3.5 GHz, 9 W, 12 V
 POWER FET
 GaAs PHEMT**

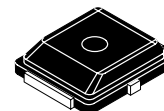

**CASE 466-03, STYLE 1
 PLD-1.5
 PLASTIC**

ARCHIVE INFORMATION

ARCHIVE INFORMATION

Table 1. Maximum Ratings

Rating	Symbol	Value	Unit
Drain-Source Voltage	V_{DSS}	15	Vdc
Total Device Dissipation @ $T_C = 25^\circ\text{C}$ Derate above 25°C	P_D	22.7 ⁽²⁾ 0.15 ⁽²⁾	W W/ $^\circ\text{C}$
Gate-Source Voltage	V_{GS}	-5	Vdc
RF Input Power	P_{in}	33	dBm
Storage Temperature Range	T_{stg}	-65 to +150	$^\circ\text{C}$
Channel Temperature ⁽¹⁾	T_{ch}	175	$^\circ\text{C}$
Operating Case Temperature Range	T_C	-20 to +85	$^\circ\text{C}$

Table 2. Thermal Characteristics

Characteristic	Symbol	Value	Unit
Thermal Resistance, Junction to Case	$R_{\theta JC}$	6.6 ⁽²⁾	$^\circ\text{C}/\text{W}$

Table 3. Moisture Sensitivity Level

Test Methodology	Rating	Package Peak Temperature	Unit
Per JESD 22-A113, IPC/JEDEC J-STD-020	1	260	$^\circ\text{C}$

1. For reliable operation, the operating channel temperature should not exceed 150°C .
2. Simulated.

Table 4. Electrical Characteristics ($T_C = 25^\circ\text{C}$ unless otherwise noted)

Characteristic	Symbol	Min	Typ	Max	Unit
Saturated Drain Current ($V_{DS} = 3.5\text{ Vdc}$, $V_{GS} = 0\text{ Vdc}$)	I_{DSS}	—	2.9	—	Adc
Off State Leakage Current ($V_{GS} = -0.4\text{ Vdc}$, $V_{DS} = 0\text{ Vdc}$)	I_{GSS}	—	< 1.0	100	μAdc
Off State Drain Current ($V_{DS} = 12\text{ Vdc}$, $V_{GS} = -1.9\text{ Vdc}$)	I_{DSO}	—	0.1	1.0	mAdc
Off State Current ($V_{DS} = 28.5\text{ Vdc}$, $V_{GS} = -2.5\text{ Vdc}$)	I_{DSX}	—	2.0	15	mAdc
Gate-Source Cut-off Voltage ($V_{DS} = 3.5\text{ Vdc}$, $I_{DS} = 15\text{ mA}$)	$V_{GS(th)}$	-1.2	-1.0	-0.7	Vdc
Quiescent Gate Voltage ($V_{DS} = 12\text{ Vdc}$, $I_{DQ} = 180\text{ mA}$)	$V_{GS(Q)}$	-1.2	-0.95	-0.7	Vdc
Power Gain ($V_{DD} = 12\text{ Vdc}$, $I_{DQ} = 180\text{ mA}$, $f = 3.55\text{ GHz}$)	G_{ps}	9.0	10	—	dB
Output Power, 1 dB Compression Point ($V_{DD} = 12\text{ Vdc}$, $I_{DQ} = 180\text{ mA}$, $f = 3.55\text{ GHz}$)	P_{1dB}	—	9	—	W
Drain Efficiency ($V_{DD} = 12\text{ Vdc}$, $I_{DQ} = 180\text{ mA}$, $P_{out} = 900\text{ mW Avg.}$, $f = 3.55\text{ GHz}$)	η_D	23	28	—	%
Adjacent Channel Power Ratio ($V_{DD} = 12\text{ Vdc}$, $P_{out} = 900\text{ mW Avg.}$, $I_{DQ} = 180\text{ mA}$, $f = 3.55\text{ GHz}$, W-CDMA, 8.5 P/A @ 0.01% Probability, 64 CH, 3.84 MCPS)	ACPR	—	-43	-40	dBc

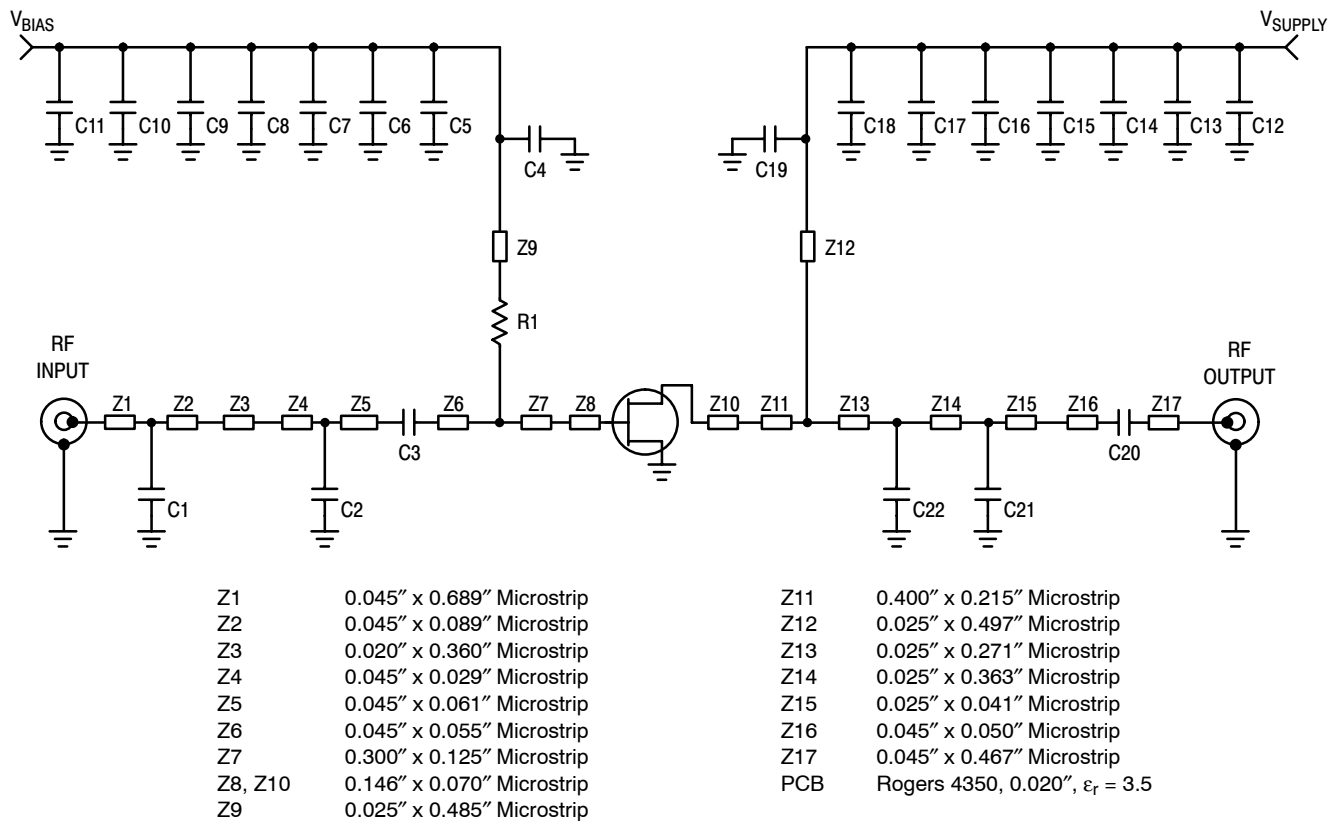
Figure 1. 3.5 GHz Test Circuit Schematic
Table 5. 3.5 GHz Test Circuit Component Designations and Values

Part	Description	Part Number	Manufacturer
C1, C21, C22	0.5 pF Chip Capacitors	08051J0R5BBT	AVX
C2	0.2 pF Chip Capacitor	06035J0R2BBT	AVX
C3	0.5 pF Chip Capacitor	06035J0R5BBT	AVX
C4, C19, C20	6.8 pF Chip Capacitors	08051J6R8BBT	AVX
C5, C18	10 pF Chip Capacitors	100A100JP150X	ATC
C6, C17	100 pF Chip Capacitors	100A101JP150X	ATC
C7, C16	100 pF Chip Capacitors	100B101JP500X	ATC
C8, C15	1000 pF Chip Capacitors	100B102JP50X	ATC
C9, C14	0.1 μ F Chip Capacitors	CDR33BX104AKWS	Kemet
C10, C13	39K pF Chip Capacitors	200B393KP50X	ATC
C11, C12	10 μ F Chip Capacitors	GRM55DR61H106KA88B	Kemet
R1	47 Ω Chip Resistor	D55342M07B47JOR	Newark

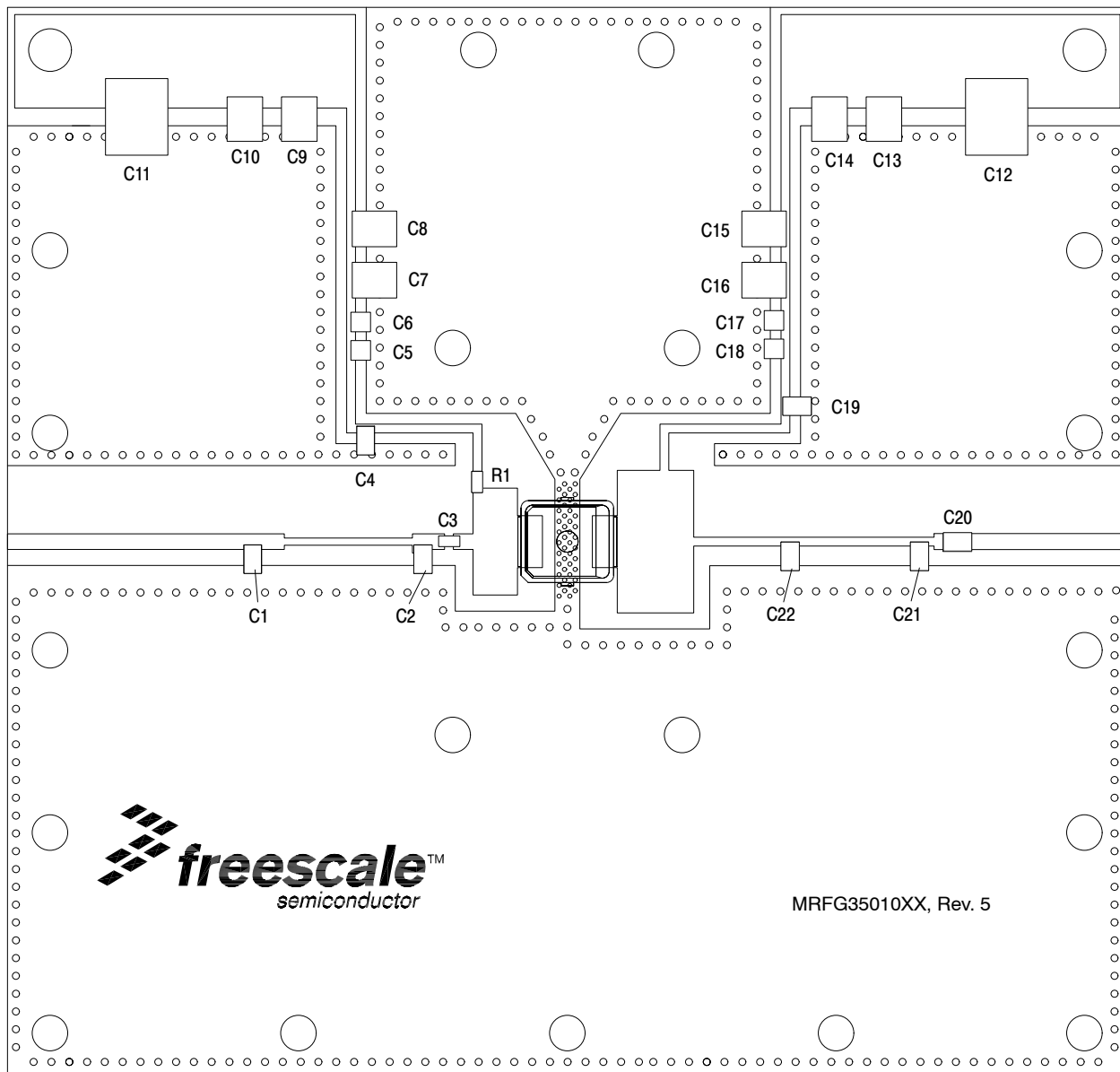

Figure 2. 3.5 GHz Test Circuit Component Layout

TYPICAL CHARACTERISTICS

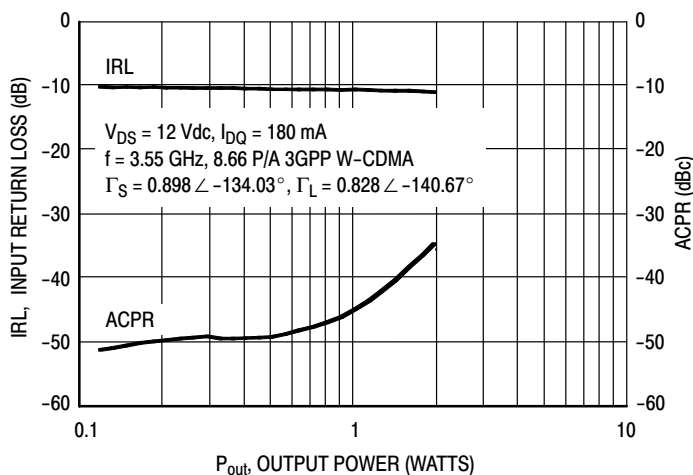

Figure 3. W-CDMA ACPR and Input Return Loss versus Output Power

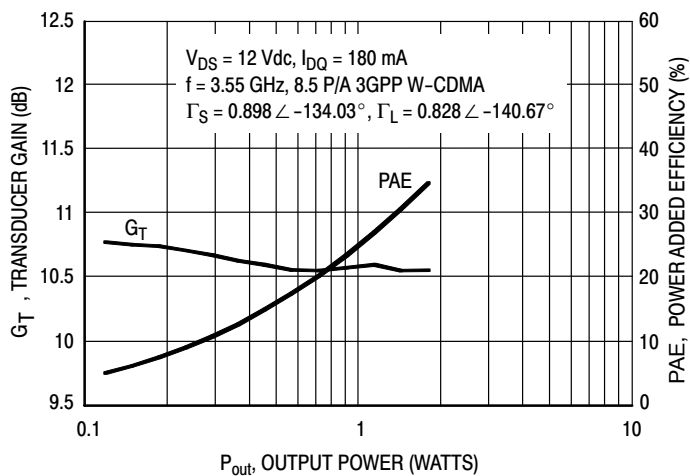

Figure 4. Transducer Gain and Power Added Efficiency versus Output Power

NOTE: All data is referenced to package lead interface. Γ_S and Γ_L are the impedances presented to the DUT. All data is generated from load pull, not from the test circuit shown.

Table 6. Class AB Common Source S-Parameters at $V_{DS} = 12$ Vdc, $I_{DQ} = 180$ mA

f GHz	S ₁₁		S ₂₁		S ₁₂		S ₂₂	
	S ₁₁	∠φ	S ₂₁	∠φ	S ₁₂	∠φ	S ₂₂	∠φ
0.5	0.946	-177.11	4.710	82.28	0.016	8.19	0.759	-179.39
0.55	0.945	-178.28	4.303	80.79	0.016	7.57	0.758	-179.99
0.6	0.944	-179.44	3.963	79.23	0.016	7.60	0.758	179.39
0.65	0.945	179.50	3.674	77.69	0.016	7.44	0.758	178.74
0.7	0.945	178.60	3.427	76.28	0.016	7.44	0.757	177.98
0.75	0.944	177.66	3.211	74.83	0.016	7.21	0.757	177.28
0.8	0.945	176.74	3.023	73.24	0.017	7.65	0.756	176.57
0.85	0.945	175.95	2.853	71.74	0.017	7.16	0.756	175.75
0.9	0.944	175.17	2.705	70.36	0.017	7.34	0.756	174.99
0.95	0.945	174.36	2.570	68.88	0.017	7.31	0.755	174.18
1	0.945	173.63	2.447	67.47	0.017	7.08	0.755	173.33
1.05	0.944	172.90	2.337	66.06	0.017	7.29	0.756	172.51
1.1	0.944	172.09	2.234	64.52	0.017	7.56	0.756	171.82
1.15	0.944	171.29	2.139	63.11	0.017	7.46	0.756	171.01
1.2	0.944	170.57	2.052	61.73	0.017	7.43	0.757	170.22
1.25	0.943	169.71	1.971	60.26	0.017	7.47	0.757	169.52
1.3	0.944	168.85	1.894	58.81	0.017	7.28	0.757	168.83
1.35	0.940	168.20	1.823	57.49	0.017	7.56	0.755	168.39
1.4	0.946	167.07	1.754	56.13	0.017	7.92	0.762	167.55
1.45	0.943	166.35	1.691	54.75	0.018	7.59	0.759	167.32
1.5	0.944	163.30	1.626	53.36	0.017	7.06	0.762	169.20
1.55	0.943	162.54	1.573	52.16	0.017	7.24	0.763	168.75
1.6	0.942	161.81	1.523	50.87	0.017	7.48	0.764	168.22
1.65	0.945	161.17	1.474	49.56	0.018	7.46	0.765	167.71
1.7	0.946	160.55	1.429	48.35	0.017	7.46	0.766	167.18
1.75	0.945	160.01	1.387	47.14	0.018	7.84	0.767	166.73
1.8	0.945	159.48	1.348	45.88	0.018	7.89	0.767	166.15
1.85	0.947	159.00	1.310	44.70	0.018	7.97	0.768	165.58
1.9	0.946	158.52	1.274	43.55	0.018	7.87	0.770	165.10
1.95	0.945	158.06	1.240	42.30	0.018	7.89	0.769	164.54
2	0.948	157.71	1.209	41.23	0.018	7.61	0.771	164.05
2.05	0.947	157.30	1.179	40.16	0.018	7.78	0.772	163.59
2.1	0.947	156.92	1.152	39.09	0.018	7.65	0.773	163.12
2.15	0.948	156.58	1.127	37.97	0.018	7.40	0.773	162.56
2.2	0.948	156.32	1.102	36.90	0.019	7.22	0.773	162.01
2.25	0.948	156.04	1.079	35.82	0.019	6.98	0.775	161.53
2.3	0.949	155.73	1.058	34.70	0.019	7.24	0.775	161.05
2.35	0.949	155.33	1.037	33.62	0.019	7.52	0.775	160.43
2.4	0.948	154.99	1.019	32.54	0.019	7.60	0.776	159.99
2.45	0.948	154.57	1.002	31.44	0.019	7.49	0.777	159.53
2.5	0.948	154.13	0.986	30.35	0.019	7.69	0.776	158.91
2.55	0.946	153.68	0.971	29.28	0.019	8.05	0.777	158.40
2.6	0.946	153.15	0.957	28.12	0.020	8.01	0.777	157.88
2.65	0.946	152.54	0.943	26.91	0.020	8.01	0.776	157.34
2.7	0.945	151.98	0.930	25.73	0.020	7.82	0.777	156.80
2.75	0.943	151.22	0.918	24.52	0.021	7.27	0.778	156.36

ARCHIVE INFORMATION

ARCHIVE INFORMATION

Table 6. Class AB Common Source S-Parameters at $V_{DS} = 12$ Vdc, $I_{DQ} = 180$ mA (continued)

f GHz	S ₁₁		S ₂₁		S ₁₂		S ₂₂	
	S ₁₁	∠φ	S ₂₁	∠φ	S ₁₂	∠φ	S ₂₂	∠φ
2.8	0.943	150.66	0.906	23.27	0.021	6.42	0.776	155.80
2.85	0.943	149.88	0.894	22.02	0.022	5.21	0.777	155.28
2.9	0.942	149.16	0.883	20.80	0.021	4.17	0.778	154.81
2.95	0.942	148.32	0.872	19.56	0.021	4.03	0.778	154.25
3	0.943	147.41	0.862	18.28	0.021	3.53	0.778	153.67
3.05	0.942	146.51	0.853	16.96	0.022	3.11	0.780	153.18
3.1	0.940	145.45	0.842	15.64	0.022	2.65	0.780	152.64
3.15	0.940	144.41	0.833	14.29	0.022	2.43	0.779	152.04
3.2	0.941	143.33	0.823	13.00	0.022	2.48	0.782	151.43
3.25	0.938	142.25	0.814	11.67	0.022	2.48	0.781	150.92
3.3	0.939	141.15	0.804	10.32	0.022	2.08	0.781	150.33
3.35	0.939	140.02	0.795	8.97	0.022	1.99	0.782	149.74
3.4	0.938	138.89	0.785	7.61	0.022	2.11	0.783	149.19
3.45	0.938	137.88	0.776	6.26	0.023	2.05	0.782	148.72
3.5	0.939	136.68	0.767	4.96	0.023	1.79	0.783	147.97
3.55	0.938	135.63	0.757	3.67	0.023	1.56	0.785	147.40
3.6	0.938	134.63	0.748	2.34	0.024	1.02	0.783	146.88
3.65	0.939	133.60	0.739	1.04	0.024	0.44	0.783	146.20
3.7	0.938	132.68	0.729	-0.25	0.024	-0.54	0.785	145.61
3.75	0.937	131.84	0.720	-1.47	0.024	-1.30	0.785	145.17
3.8	0.937	130.92	0.711	-2.69	0.024	-1.98	0.785	144.52
3.85	0.938	130.07	0.702	-3.89	0.024	-2.38	0.786	143.87
3.9	0.938	129.29	0.694	-5.07	0.024	-2.22	0.787	143.24
3.95	0.939	128.60	0.686	-6.23	0.024	-2.00	0.787	142.61
4	0.939	127.88	0.678	-7.34	0.025	-1.80	0.788	141.94
4.05	0.939	127.23	0.671	-8.46	0.025	-2.04	0.789	141.34
4.1	0.941	126.66	0.664	-9.57	0.025	-2.17	0.789	140.69
4.15	0.941	126.23	0.658	-10.65	0.025	-2.15	0.788	140.01
4.2	0.940	125.73	0.651	-11.72	0.026	-2.48	0.789	139.31
4.25	0.939	125.28	0.645	-12.82	0.026	-2.81	0.789	138.65
4.3	0.940	124.85	0.640	-13.86	0.026	-2.79	0.788	137.91
4.35	0.940	124.45	0.635	-14.92	0.027	-2.73	0.789	137.16
4.4	0.939	124.01	0.630	-16.00	0.027	-3.22	0.789	136.45
4.45	0.939	123.63	0.627	-17.01	0.028	-3.26	0.788	135.67
4.5	0.939	123.27	0.623	-18.03	0.028	-3.64	0.788	134.88
4.55	0.937	122.84	0.620	-19.03	0.029	-3.74	0.789	134.16
4.6	0.937	122.32	0.619	-20.17	0.029	-4.57	0.788	133.36
4.65	0.937	121.88	0.618	-21.26	0.030	-5.02	0.788	132.50
4.7	0.936	121.36	0.617	-22.45	0.030	-6.01	0.788	131.67
4.75	0.935	120.72	0.615	-23.68	0.031	-7.22	0.787	130.83
4.8	0.935	120.04	0.614	-24.90	0.031	-7.64	0.786	129.91
4.85	0.934	119.35	0.613	-26.12	0.031	-8.05	0.786	129.03
4.9	0.932	118.49	0.613	-27.41	0.031	-8.39	0.786	128.20
4.95	0.931	117.69	0.614	-28.72	0.032	-8.32	0.785	127.24
5	0.929	116.74	0.614	-30.05	0.033	-8.48	0.786	126.32

ARCHIVE INFORMATION

ARCHIVE INFORMATION

NOTES

NOTES

NOTES

PACKAGE DIMENSIONS

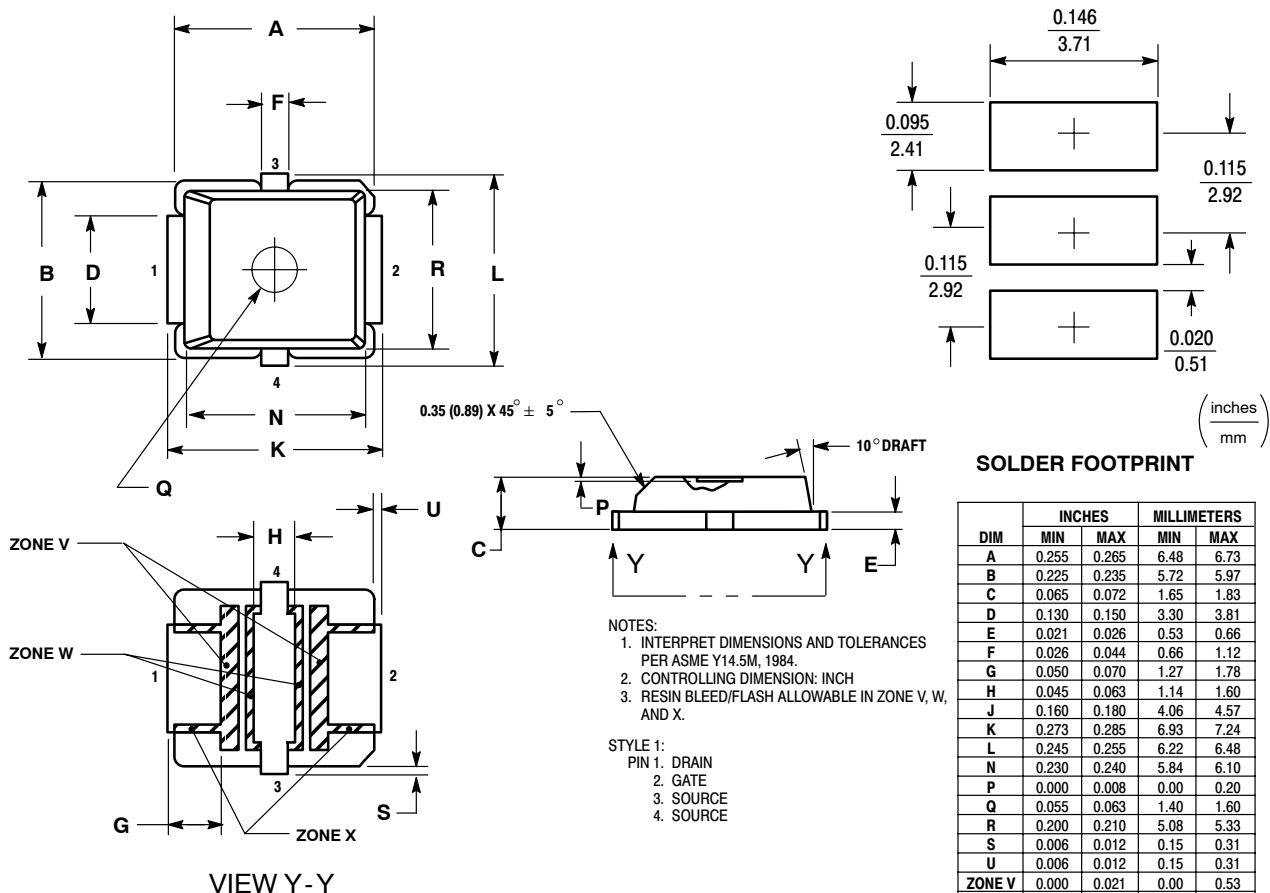

**CASE 466-03
 ISSUE D
 PLD-1.5
 PLASTIC**

How to Reach Us:

Home Page:

www.freescale.com

E-mail:

support@freescale.com

USA/Europe or Locations Not Listed:

Freescale Semiconductor
Technical Information Center, CH370
1300 N. Alma School Road
Chandler, Arizona 85224
+1-800-521-6274 or +1-480-768-2130
support@freescale.com

Europe, Middle East, and Africa:

Freescale Halbleiter Deutschland GmbH
Technical Information Center
Schatzbogen 7
81829 Muenchen, Germany
+44 1296 380 456 (English)
+46 8 52200080 (English)
+49 89 92103 559 (German)
+33 1 69 35 48 48 (French)
support@freescale.com

Japan:

Freescale Semiconductor Japan Ltd.
Headquarters
ARCO Tower 15F
1-8-1, Shimo-Meguro, Meguro-ku,
Tokyo 153-0064
Japan
0120 191014 or +81 3 5437 9125
support.japan@freescale.com

Asia/Pacific:

Freescale Semiconductor Hong Kong Ltd.
Technical Information Center
2 Dai King Street
Tai Po Industrial Estate
Tai Po, N.T., Hong Kong
+800 2666 8080
support.asia@freescale.com

For Literature Requests Only:

Freescale Semiconductor Literature Distribution Center
P.O. Box 5405
Denver, Colorado 80217
1-800-441-2447 or 303-675-2140
Fax: 303-675-2150
LDCForFreescaleSemiconductor@hibbertgroup.com

Information in this document is provided solely to enable system and software implementers to use Freescale Semiconductor products. There are no express or implied copyright licenses granted hereunder to design or fabricate any integrated circuits or integrated circuits based on the information in this document.

Freescale Semiconductor reserves the right to make changes without further notice to any products herein. Freescale Semiconductor makes no warranty, representation or guarantee regarding the suitability of its products for any particular purpose, nor does Freescale Semiconductor assume any liability arising out of the application or use of any product or circuit, and specifically disclaims any and all liability, including without limitation consequential or incidental damages. "Typical" parameters that may be provided in Freescale Semiconductor data sheets and/or specifications can and do vary in different applications and actual performance may vary over time. All operating parameters, including "Typicals", must be validated for each customer application by customer's technical experts. Freescale Semiconductor does not convey any license under its patent rights nor the rights of others. Freescale Semiconductor products are not designed, intended, or authorized for use as components in systems intended for surgical implant into the body, or other applications intended to support or sustain life, or for any other application in which the failure of the Freescale Semiconductor product could create a situation where personal injury or death may occur. Should Buyer purchase or use Freescale Semiconductor products for any such unintended or unauthorized application, Buyer shall indemnify and hold Freescale Semiconductor and its officers, employees, subsidiaries, affiliates, and distributors harmless against all claims, costs, damages, and expenses, and reasonable attorney fees arising out of, directly or indirectly, any claim of personal injury or death associated with such unintended or unauthorized use, even if such claim alleges that Freescale Semiconductor was negligent regarding the design or manufacture of the part.

Freescale™ and the Freescale logo are trademarks of Freescale Semiconductor, Inc. All other product or service names are the property of their respective owners.

© Freescale Semiconductor, Inc. 2006. All rights reserved.

RoHS-compliant and/or Pb-free versions of Freescale products have the functionality and electrical characteristics of their non-RoHS-compliant and/or non-Pb-free counterparts. For further information, see <http://www.freescale.com> or contact your Freescale sales representative.

For information on Freescale's Environmental Products program, go to <http://www.freescale.com/epp>.

Looking for pricing, stock, or lifecycle information?

Click below to explore more details on WIN SOURCE:

- ⊖ [View MRFG35010MT1 on WIN SOURCE](#)
- ⊖ [Freescale Semiconductor - NXP Information](#)

Optimize Your Supply Chain with WIN SOURCE Solutions

- ✓ Global Sourcing Solution
- ✓ Obsolete Management
- ✓ Cost Control Management
- ✓ Shortage Management
- ✓ Alternative Solution
- ✓ Excess Inventory Management