



**THE DATASHEET OF
MS-156HF(01)**



Subminiature Coaxial Switch 1.6 mm High, DC to 6 GHz

MS-156HF Series

Halogen Free

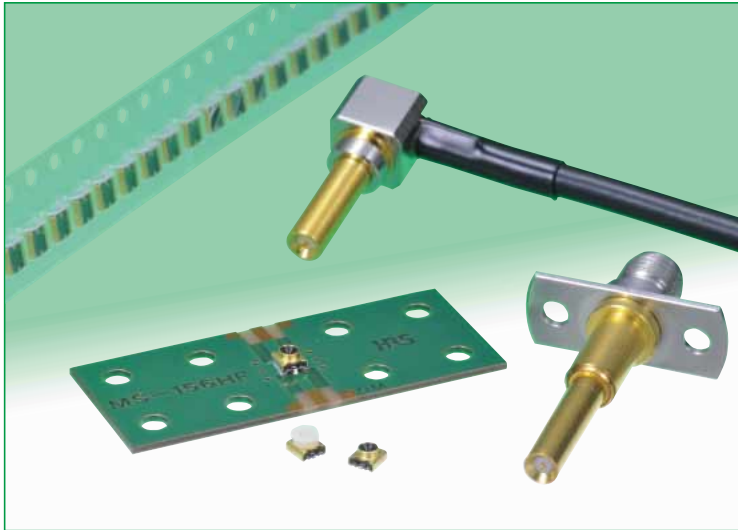

Overview

Developed for inspection of high frequency circuits used in portable terminals. Verification of the circuit performance is accomplished by simply inserting the external plug in the board mounted receptacle. This action re-directs the circuit from normal condition to the plug side. Removing the plug restores circuit to its normal condition.

Space-saving design
Low profile -1.6 mm protrusion above the board.
Lightweight -0.025 g. total weight.

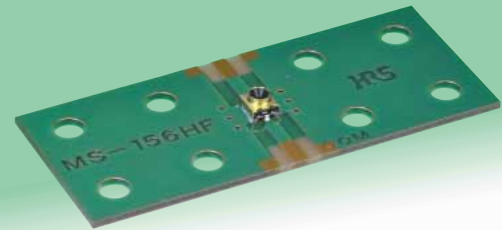

MS-156HF

Features

1. Low insertion loss

0.1 dB typical at 6 GHz (not mated with the plug).

2. Space-saving design

2.7 mm x 2.7 mm occupied board space.

3. Low profile

1.6 mm protrusion above the board.

4. Lightweight

0.025 g. total weight (without vacuum cap).

5. Durability

100 mating/unmating cycles, with corresponding plug.

6. Performs over a wide frequency range

Applicable frequencies range over a wide band, from DC to 6 GHz.

7. Solder wicking prevention

Nickel plating barrier on the contacts prevents solder compound intrusion (wicking) into the contact engagement areas.

8. Board placement with automatic equipment

Packaged on tape-and-reel. Also available with a vacuum pick-up cap over each switch.

9. RoHS compliant

All components and materials comply with the requirements of the EU Directive 2002/95/EC.

10. Halogen Free

Chlorine, and bromine are not used in the receptacles.

*Definition according to IEC 61249-2-21.

Br 900 ppm max., Cl 900 ppm max., and Br + Cl 1500 ppm max.

Applications

Portable terminals, ETC, notebook computers (Bluetooth), wireless LAN, POS terminals, GPS terminals, PDA, and any small devices requiring verification of antenna/circuit performance.

Several types of plugs

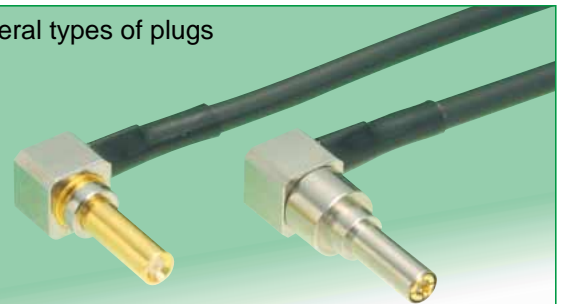

Several types of SMA conversion adapters



Adapter for plug inspection



■ Specifications

	Not mated with the plug	Mated (MS-156-HRMJ-3)
Operating temperature range	-40°C to +85°C	-40°C to +85°C
Rated power	2W	2W
Frequency range	DC to 6GHz	DC to 6GHz
Insertion loss	0.1 dB max. (DC to 2.5GHz) 0.15 dB max. (2.5GHz to 6.0GHz)	0.5 dB max. (DC to 3.0GHz) 1.2 dB max. (3.0GHz to 6.0GHz)
Isolation	20 dB max. (DC to 2.0GHz) 15 dB max. (2.0GHz to 4.0GHz) 13 dB max. (4.0GHz to 6.0GHz)	
V.S.W.R	1.2 max. (DC to 2.5GHz) 1.3 max. (2.5GHz to 6.0GHz)	1.4 max. (DC to 3.0GHz) 1.8 max. (3.0GHz to 6.0GHz)

Item	Specification	Conditions
1. Contact resistance	100 mΩ max.	100 mA max.
2. Insulation resistance	1000 MΩ min.	100 V DC
3. Withstanding voltage	No flashover or insulation breakdown	100 V AC / 1 minute
4. Vibration	No electrical discontinuity of 1 μs or more	Frequency: 10 to 55 Hz, single amplitude of 0.75 mm, 2 hours in each of the 3 axis.
5. Shock		Acceleration of 490 m/s ² , 6 ms duration, sine half-wave waveform, 3 cycles in each of the 3 axis
6. Temperature cycle	Contact resistance: 100 mΩ max. Insulation resistance: 10 MΩ min.	Temperature: -55°C → +5°C to +35°C → +85°C → +5°C to +35°C Time: 30 → 2 to 3 → 30 → 2 to 3 (Minutes) 100 cycles
7. High temperature exposure	Contact resistance: 100 mΩ max. Insulation resistance: 10 MΩ min.	96 hours at 85°C
8. Low temperature exposure	Contact resistance: 100 mΩ max. Insulation resistance: 10 MΩ min.	96 hours at -55°C
9. Humidity	Contact resistance: 100 mΩ max. Insulation resistance: 10 MΩ min.	96 hours at 40±2°C, and humidity of 90 to 95%
10. Durability (mating/un-mating, with corresponding plug)	Contact resistance: 100 mΩ max.	100 cycles

■ Materials

Part	Material	Finish	Remarks
Shell	Phosphor bronze	Gold plated	————
Insulator	6T Nylon	————	UL94HB
Common terminal	Beryllium copper	Selective gold plated	————
Antenna terminal	Phosphor bronze	Selective gold plated	————

◆ Typical Data

● NORMALLY CLOSED(N.C)~(Not mated with the plug)

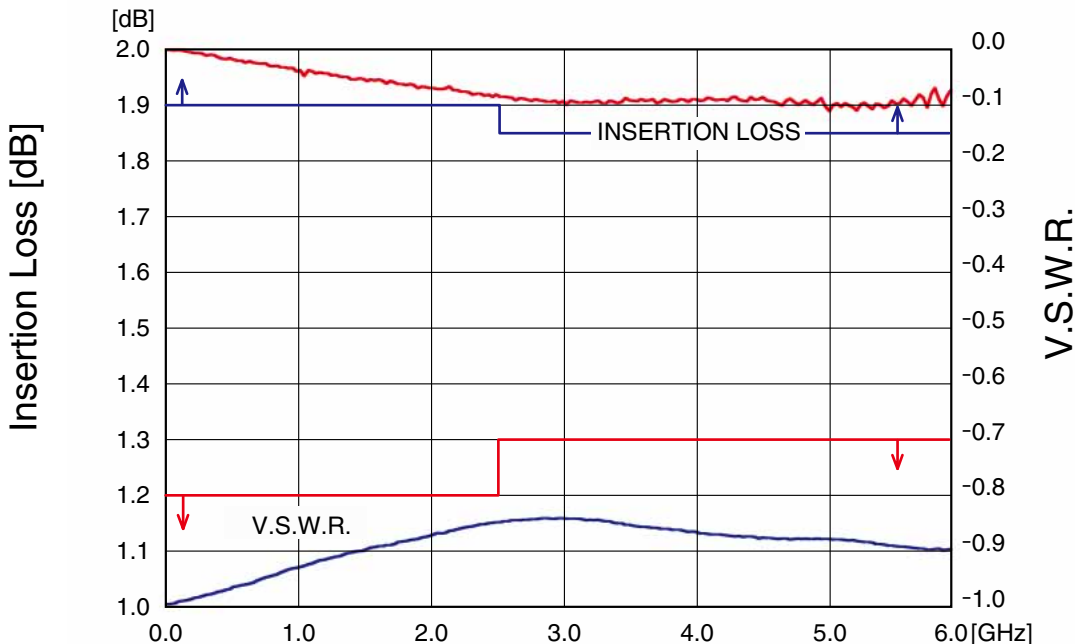

● OPEN(N.O)~(Mated with the plug)

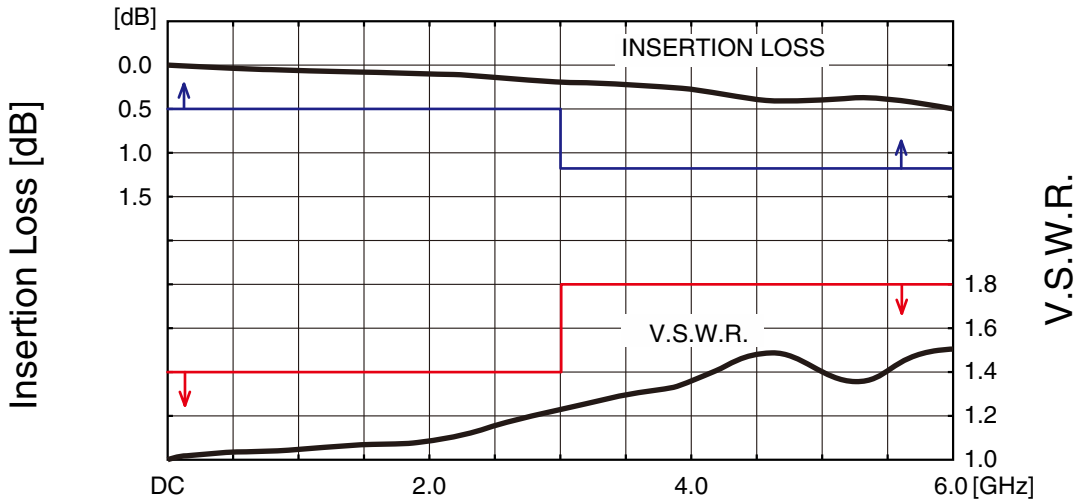

● ISOLATION

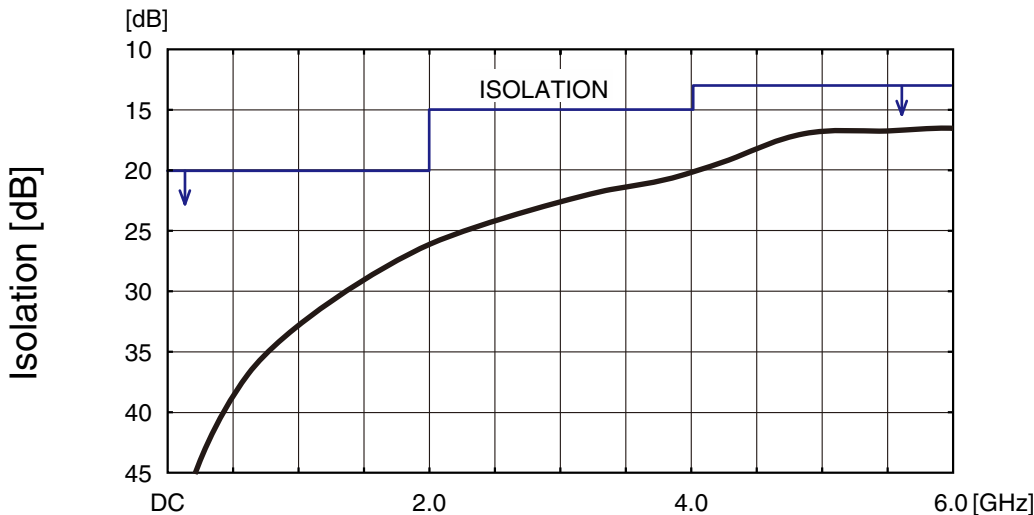

Aug.1.2019 Copyright 2019 HIROSE ELECTRIC CO., LTD. All Rights Reserved.

■ Receptacle

● Without vacuum pick-up cap

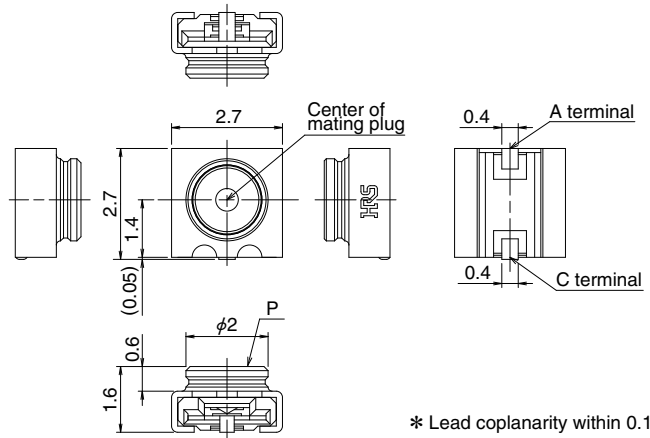

* Lead coplanarity within 0.1mm

Part Number	CL No.	Packaging
MS-156HF	358-0238-4	10,000 pieces/reel
MS-156HF(01)	358-0238-4-01	100 pieces/bag
MS-156HF(20)	358-0238-4-20	2,000 pieces/reel

● With vacuum pick-up cap

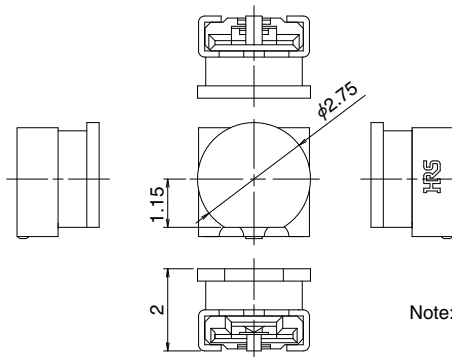
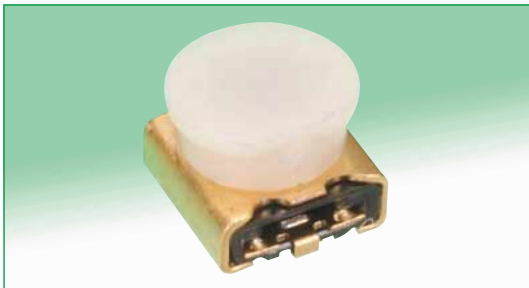

Note: Vacuum pick-up cap flat can be oriented in any direction. Orientation will not affect placement of the switch on the board.

Part Number	CL No.	Packaging
MS-156HF(02)	358-0238-4-02	8,500 pieces/reel
MS-156HF(22)	358-0238-4-22	1,500 pieces/reel

◆ Circuit diagram

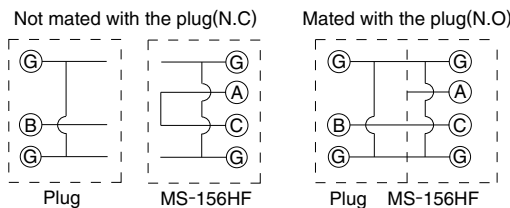

◆ PCB mounting pattern and metal mask dimensions

- * Request drawing of the specific part for exact dimensions and tolerances.
- * Specified dimensions must be followed to assure correct board placement and performance.

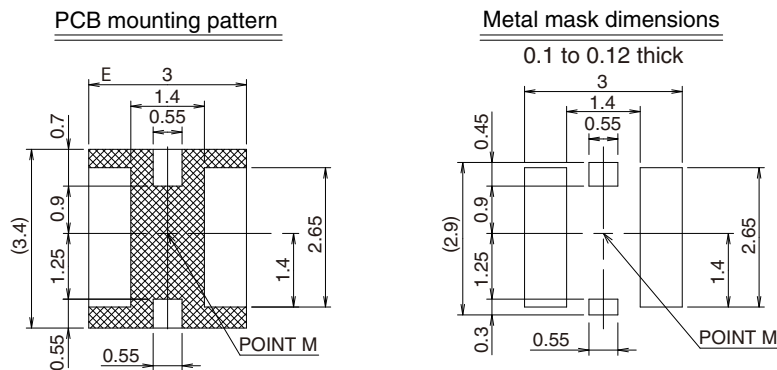

▨ This area must be free of conductive traces and resist field.

◆ Precautions

1. This product is intended to be used for circuit inspection only. Consult us if any other application is considered.
2. Cross-hatched area shown on the PCB mounting pattern must be free of any conductive traces. Placing conductive traces in this area may affect performance and will void product warranties. When the bottom surface of the product (i.e., the  shaded area of the specified land dimensions diagram on the previous page) has been processed with a substrate copper trace and resist processing, Hirose Electric will not be able to warrant the product.
3. Do not use hand soldering for mounting of MS-156HF.
Doing so could result in solder and flux wicking to the contact areas.
4. Exercise caution as not to allow any debris to enter the board mounted MS-156HF when cutting PCB.

Recommended Mounting of MS-156HF coaxial switch
on the PCB during the manufacturing process

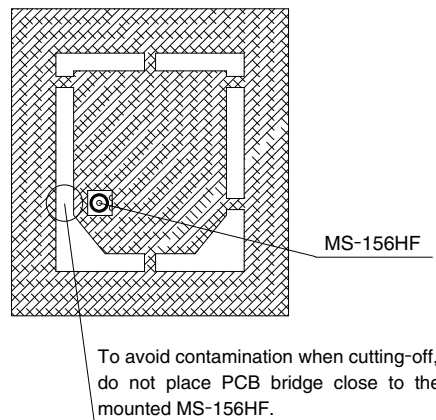

5. Do not use the washing process.
6. Please refrain from using the product in environments specifically affected by excessive vibration, shock, dust, high humidity, gases, very high temperatures and very low temperatures such as outdoor equipment. It might cause degradation or destruction of the product. Even if it endures during a short time, long time qualification is not guaranteed.
7. For use of this product, be sure to put contact area of plug on position P(P4 full view) perpendicularly.
8. Plugs can be roughly classified to two types.
 - For mass production line automatic check (Press down type)
 - For manual check (With retentive lock) : Unable to be used at production line.
9. When automatic inspections are to be performed during the manufacturing operations, request the MS-156 plug connector manual for examples of implementation.

◆ Packaging Specifications

● Without vacuum cap

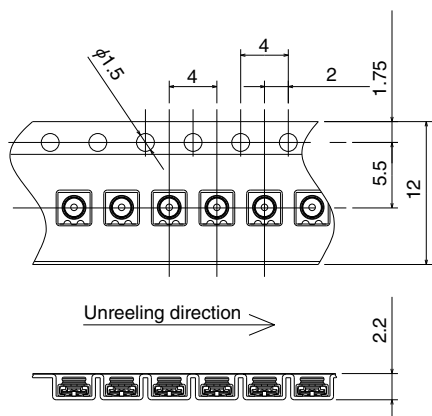

● Reel dimensions

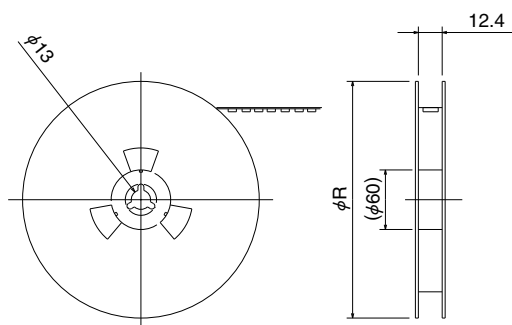

Part Number	Reel Size	Packaging
MS-156HF	R = φ380mm	10,000 pieces/reel
MS-156HF(20)	R = φ180mm	2,000 pieces/reel

● With vacuum cap

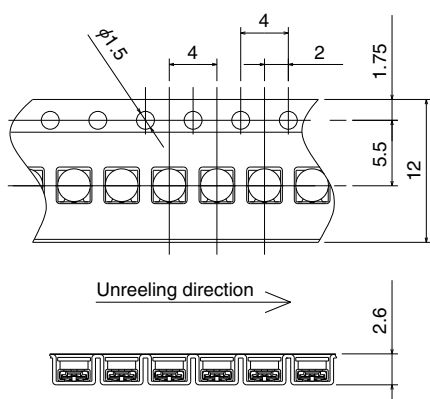

● Reel dimensions

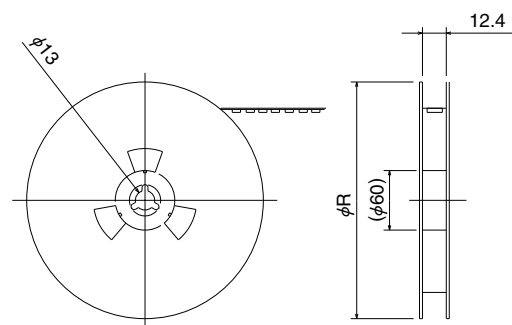

Part Number	Reel Size	Packaging
MS-156HF(02)	R = φ380mm	8,500 pieces/reel
MS-156HF(22)	R = φ180mm	1,500 pieces/reel

◆ Recommended Temperature Profile

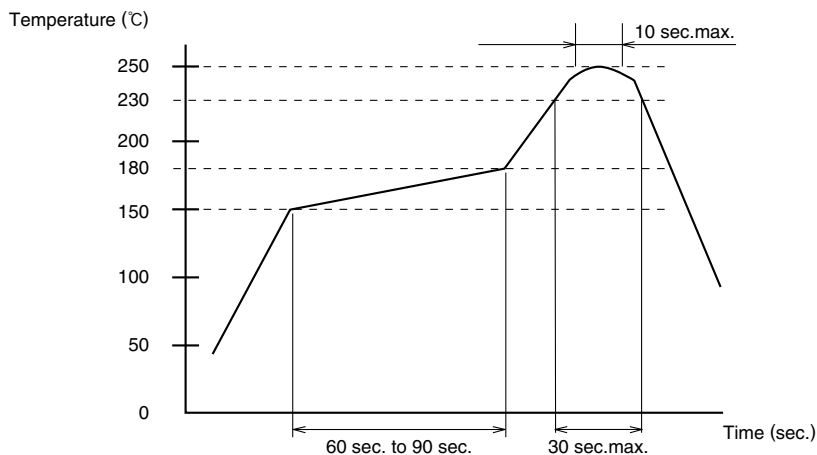

Using Lead-free Solder paste

1	Maximum temperature	: 250°C
2	Peak temperature	: 240°C to 250°C
3	Peak temperature time	: 10 sec. max.
4	230°C min.	: 30 sec. max.
5	150°C to 180°C	: 60 sec. to 90 sec.

Metal mask thickness : 0.1 to 0.12 mm
 Reflow cycles : 2 cycles

■ Plugs

● Press down, right angle

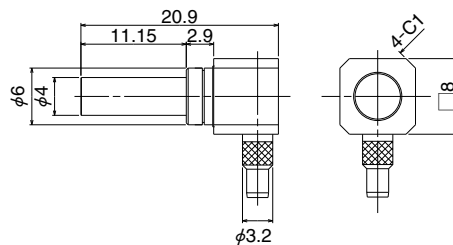

Part Number	CL No.	Durability
MS-156-C(LP)-1	358-0173-0	10,000 Times

Applicable cable: 1.5D-HQEW, 1.5D-QEW (Fujikura Ltd.)

● Simplified lock, right angle

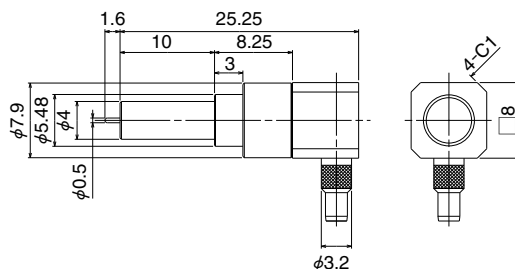

Part Number	CL No.	Durability
MS-156-C(LP)-2	358-0174-3	500 Times

Applicable cable: 1.5D-HQEW, 1.5D-QEW (Fujikura Ltd.)

■ SMA Conversion Adapters

● Simplified lock, straight, short

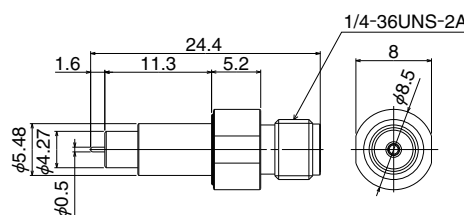

Part Number	CL No.	Durability
MS-156-HRMJ-2	358-0170-2	500 Times

● Simplified lock, straight, long

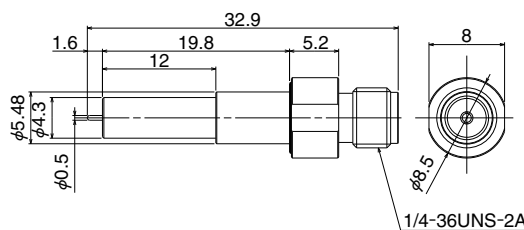

Part Number	CL No.	Durability
MS-156-HRMJ-5	358-0177-1	500 Times

● Press down, with flange, short

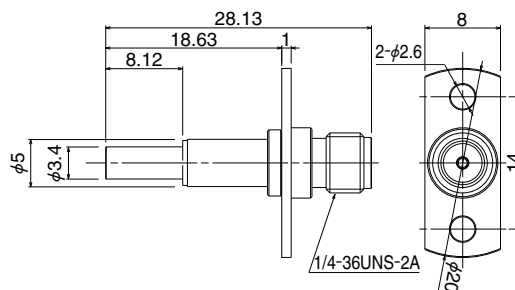
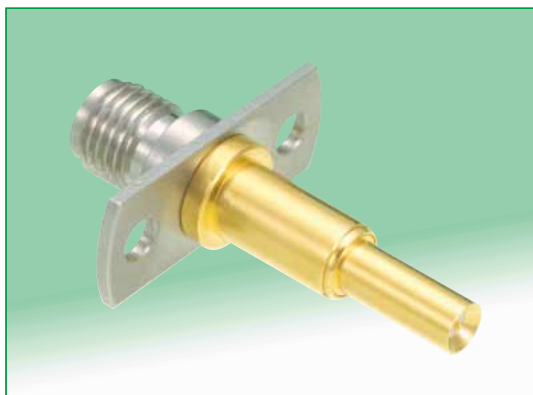

Part Number	CL No.	Durability
MS-156-HRMJ-3	358-0171-5	10,000 Times

● Press down, with flange, long

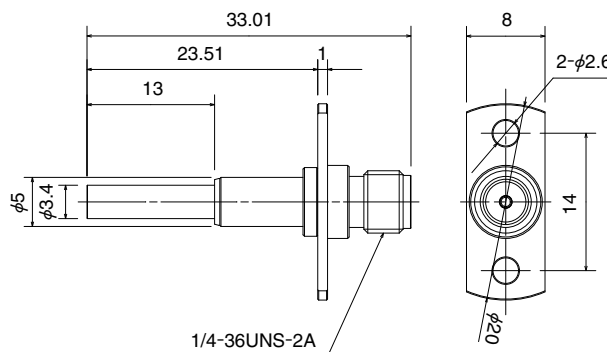
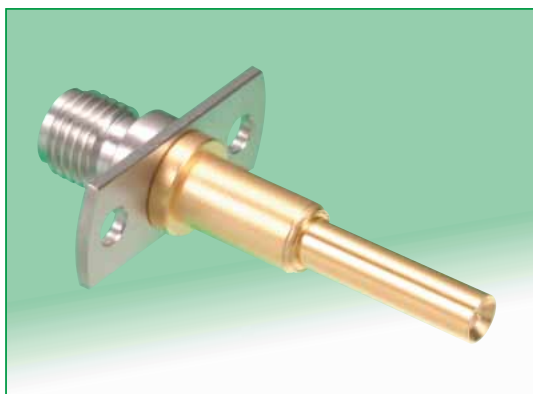

Part Number	CL No.	Durability
MS-156-HRMJ-14	358-0198-1	10,000 Times

● Press down, with flange
(Increased self alignment)

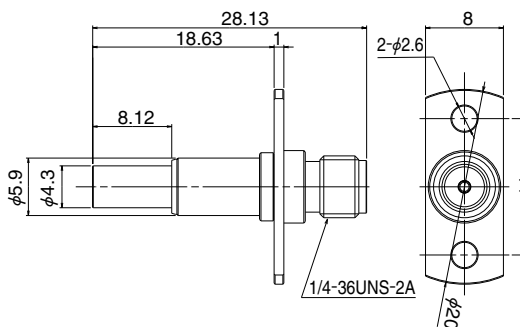
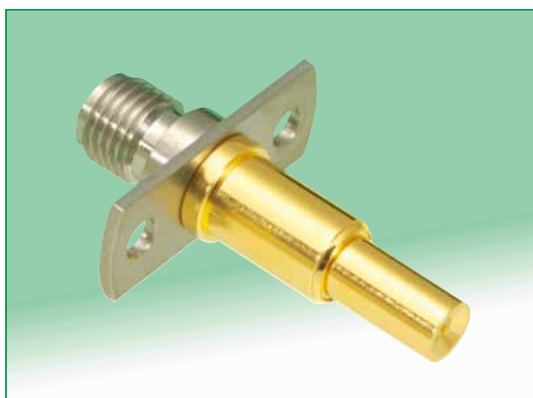

Part Number	CL No.	Durability
MS-156-HRMJ-6	358-0181-9	10,000 Times

● Floating

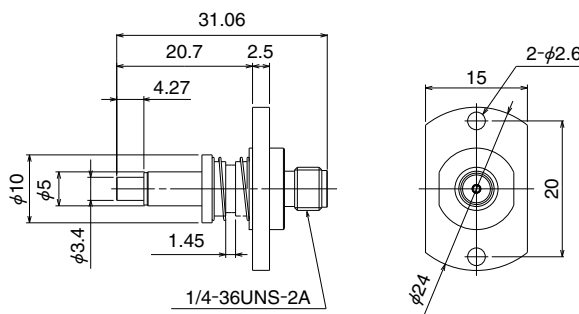

Part Number	CL No.	Durability
MS-156-HRMJ-9	358-0180-6	10,000 Times

Aug.1.2019 Copyright 2019 HIROSE ELECTRIC CO., LTD. All Rights Reserved.

● Floating (Self-Pressing)

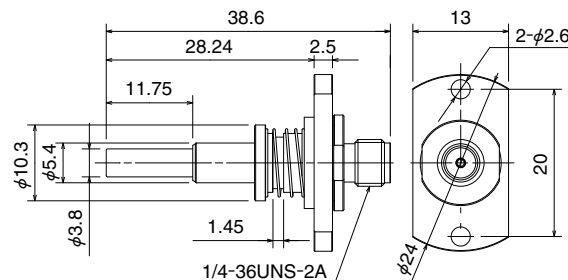
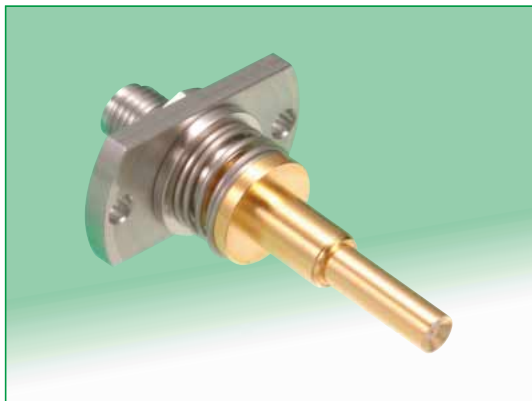

Part Number	CL No.	Durability
MS-156-HRMJ-10	358-0194-0	10,000 Times

● Floating (Self-Pressing)

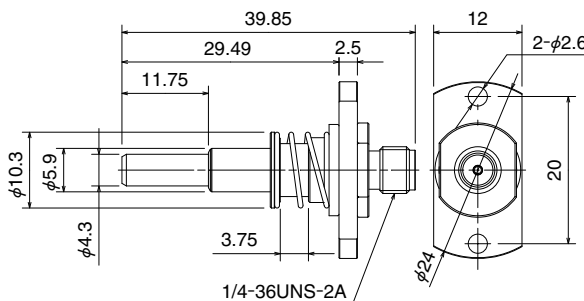

Part Number	CL No.	Durability
MS-156-HRMJ-12	358-0196-6	10,000 Times

● Floating (Self-Pressing)

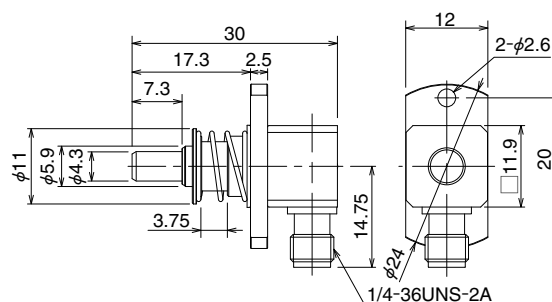
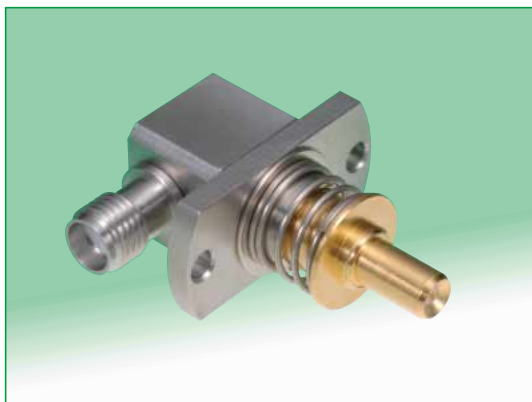

Part Number	CL No.	Durability
MS-156LP-HRMJ-4	358-0205-5	10,000 Times

● Adapter for plug inspection

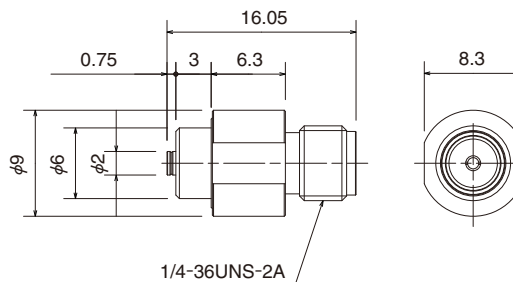

Part Number	CL No.	Durability
MS-156R-HRMJ-1	358-0188-8	500 Times

Aug.1.2019 Copyright 2019 HIROSE ELECTRIC CO., LTD. All Rights Reserved.

● Adapter for plug inspection

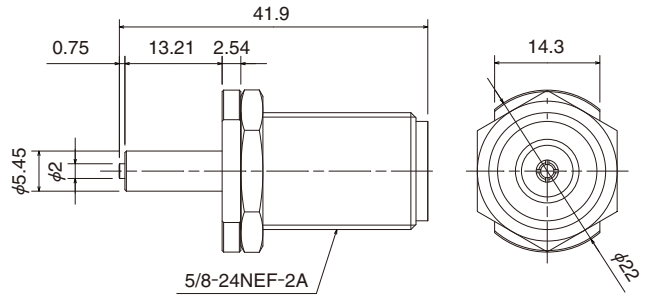
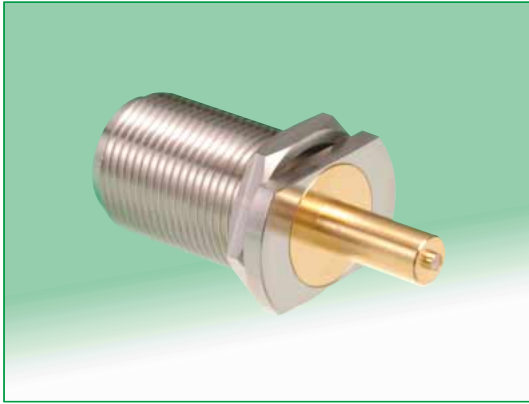

Part Number	CL No.	Durability
MS-156R-NJ-1	358-0176-9	500 Times

USA:

HIROSE ELECTRIC (U.S.A.), INC. Headquarters

2688 Westhills Court, Simi Valley, CA 93065-6235
 Phone : 1-805-522-7958
 Fax : 1-805-522-3217
<http://www.hiroseusa.com>

USA:

HIROSE ELECTRIC (U.S.A.), INC. North California Office

20400 Stevens Creek Blvd., Ste 250, Cupertino, CA 95014
 Phone : 1-408-253-9640
 Fax : 1-408-253-9641
<http://www.hiroseusa.com>

USA:

HIROSE ELECTRIC (U.S.A.), INC. Dallas Office

1701 N. Greenville Ave. Ste 817, Richardson, TX 75081
 Phone : 1-469-330-9200
 Fax : 1-469-330-9205
<http://www.hiroseusa.com>

USA:

HIROSE ELECTRIC (U.S.A.), INC. Chicago Office

2777 Finley Road, Suite 28 Downers Grove, IL 60148
 Phone : 1-630-916-1455
 Fax : 1-630-916-1451
<http://www.hiroseusa.com>

USA:

HIROSE ELECTRIC (U.S.A.), INC. New York Office

510 Broadhollow Road, Suite 305, Melville, NY 11747
 Phone : 1-516-249-5259
<http://www.hiroseusa.com>

USA:

HIROSE ELECTRIC (U.S.A.), INC. Detroit Office (Automotive)

37650 Professional Center Drive, Suite 120A, Livonia, MI 48154
 Phone : 1-734-542-9963
 Fax : 1-734-542-9964
<http://www.hiroseusa.com>

GERMANY:

HIROSE ELECTRIC GmbH

Herzog-Carl-Strasse 4 D-73760 Ostfildern (Scharnhäuser Park)
 Phone : 49-711-4560-02-1
 Fax : 49-711-4560-02-299
<http://www.hirose.de>

THE NETHERLANDS:

HIROSE ELECTRIC EUROPE B.V.

Beechavenue 46,1119 PV Schiphol-Rijk
 Phone : 31-20-6557490
 Fax : 31-20-6557469
<http://www.hiroseeurope.com>

FINLAND:

Hirose Electric Europe B.V. Finland Office

Teknobulevardi 3-5 01530 VANTAA
 Phone : 358-9-2517-8459
 Fax : 358-9-2517-8460
<http://www.hiroseeurope.com>

UNITED KINGDOM:

HIROSE ELECTRIC UK LTD.

Crownhill Business Centre 22 Vincent Avenue Crownhill, Milton Keynes MK8 OAB
 Phone : 44-1908-305400
 Fax : 44-1908-305401
<http://www.hirose.co.uk>

CHINA:

HIROSE ELECTRIC CO., LTD. Beijing Office

Unit 1605, Block A, ZhuBang2000 BusinessCenter, No.100, Balizhuang Xili, Chaoyang District, Beijing, 10025
 Phone : 86-10-5165-9332
 Fax : 86-10-8586-1418
<http://www.hirose-china.com.cn>

CHINA:

HIROSE ELECTRIC (SHANGHAI) CO., LTD.

1501-02, Cross Tower Building 318 Fuzhou Road, Huang Pu District Shanghai, 200001
 Phone : 86-21-6391-3355
 Fax : 86-21-6391-3335
<http://www.hirose-china.com.cn>

CHINA:

HIROSE ELECTRIC CO., LTD. Shenzhen Office

Room 1902-05, Office Tower Shun Hing Square, DiWang Commercial Centre 5002 ShenNanDong Road, ShenZhen
 Phone : 86-755-8207-0851
 Fax : 86-755-8207-0873
<http://www.hirose-china.com.cn>

HONG KONG:

HIROSE ELECTRIC CO., LTD.

Unit 1102, Energy Plaza, 92 Granville Road, Tsim Sha Tsui East, Kowloon
 Phone : 852-2803-5338
 Fax : 852-2591-6560
<http://www.hirose-hongkong.com.hk>

TAIWAN:

HIROSE ELECTRIC TAIWAN CO., LTD.

No.28 Lane 247 Sec. 2 Yen Ping N,Rd.Taipei
 Phone : 886-2-2557-7351,7352
 Fax : 886-2-2552-9851
<http://www.hirose-taiwan.com.tw>

SINGAPORE:

HIROSE ELECTRIC CO., LTD.

10 Anson Road #26-16 International Plaza 079903
 Phone : 65-6324-6113
 Fax : 65-6324-6123
<http://www.hirose-singapore.com.sg>

KOREA:

HIROSE KOREA CO., LTD.

(#2NA311,Shihwa Industrial Complex),1261-10, Jeungwhang-Dong, Shihung-City, Kyunggi-Do 429-450
 Phone : 82-31-496-7000,7124
 Fax : 82-31-496-7100
<http://www.hirose.co.kr>



HIROSE ELECTRIC CO.,LTD.

5-23,OSAKI 5-CHOME,SHINAGAWA-KU,TOKYO 141-8587,JAPAN
 PHONE: 81-3-3491-9741, FAX: 81-3-3493-2933
<http://www.hirose.com>
<http://www.hirose-connectors.com>

Aug. 1. 2019 Copyright 2019 HIROSE ELECTRIC CO., LTD. All Rights Reserved.

Looking for pricing, stock, or lifecycle information?

Click below to explore more details on WIN SOURCE:

- ⊖ [View MS-156HF\(01\) on WIN SOURCE](#)
- ⊖ [Hirose Electric Co Ltd Information](#)

Optimize Your Supply Chain with WIN SOURCE Solutions

- ✓ Global Sourcing Solution
- ✓ Obsolete Management
- ✓ Cost Control Management
- ✓ Shortage Management
- ✓ Alternative Solution
- ✓ Excess Inventory Management