

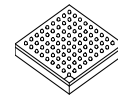

**THE DATASHEET OF  
MSC8113TMP3600V**



## MSC8113



FC-PBGA-431  
20 mm × 20 mm

### Tri-Core Digital Signal Processor

- Three StarCore™ SC140 DSP extended cores, each with an SC140 DSP core, 224 Kbyte of internal SRAM M1 memory (1436 Kbyte total), 16 way 16 Kbyte instruction cache (ICache), four-entry write buffer, external cache support, programmable interrupt controller (PIC), local interrupt controller (LIC), and low-power Wait and Stop processing modes.
- 475 Kbyte M2 memory for critical data and temporary data buffering.
- 4 Kbyte boot ROM.
- M2-accessible multi-core MQBus connecting the M2 memory with all three cores, operating at the core frequency, with data bus access of up to 128-bit reads and up to 64-bit writes, central efficient round-robin arbiter for core access to the bus, and atomic operation control of M2 memory access by the cores and the local bus.
- Internal PLL configured are reset by configuration signal values.
- 60x-compatible system bus with 64 or 32 bit data and 32-bit address bus, support for multi-master designs, four-beat burst transfers (eight-beat in 32-bit data mode), port size of 64/32/16/8 bits controlled by the internal memory controller, access to external memory or peripherals, access by an external host to internal resources, slave support with direct access to internal resources including M1 and M2 memories, and on-device arbitration for up to four master devices.
- Direct slave interface (DSI) using a 32/64-bit slave host interface with 21–25 bit addressing and 32/64-bit data transfers, direct access by an external host to internal and external resources, synchronous or asynchronous accesses with burst capability in synchronous mode, dual or single strobe mode, write and read buffers to improve host bandwidth, byte enable signals for 1/2/4/8-byte write granularity, sliding window mode for access using a reduced number of address pins, chip ID decoding to allow one  $\overline{CS}$  signal to control multiple DSPs, broadcast mode to write to multiple DSPs, and big-endian/little-endian/munged support.
- Three mode signal multiplexing: 64-bit DSI and 32-bit system bus, 32-bit DSI and 64-bit system bus, or 32-bit DSI and 32-bit system bus, and Ethernet port (MII/RMII).
- Flexible memory controller with three UPMs, a GPCM, a page-mode SDRAM machine, glueless interface to a variety of memories and devices, byte enables for 64- or 32-bit bus widths, 8 memory banks for external memories, and 2 memory banks for IPBus peripherals and internal memories.
- Multi-channel DMA controller with 16 time-multiplexed single channels, up to four external peripherals,  $\overline{DONE}$  or  $\overline{DRACK}$  protocol for two external peripherals, service for up to 16 internal requests from up to 8 internal FIFOs per channel, FIFO generated watermarks and hungry requests, priority-based time-multiplexing between channels using 16 internal priority levels or round-robin time-multiplexing between channels, flexible channel configuration with connection to local bus or system bus, and flyby transfer support that bypasses the FIFO.
- Up to four independent TDM modules with programmable word size (2, 4, 8, or 16-bit), hardware-base A-law/ $\mu$ -law conversion, up to 128 Mbps data rate for all channels, with glueless interface to E1 or T1 framers, and can interface with H-MVIP/H.110 devices, TSI, and codecs such as AC-97.
- Ethernet controller with support for 10/100 Mbps MII/RMII/SMII including full- and half-duplex operation, full-duplex flow controls, out-of-sequence transmit queues, programmable maximum frame length including jumbo frames and VLAN tags and priority, retransmission after collision, CRC generation and verification of inbound/outbound packets, address recognition (including exact match, broadcast address, individual hash check, group hash check, and promiscuous mode), pattern matching, insertion with expansion or replacement for transmit frames, VLAN tag insertion, RMON statistics, local bus master DMA for descriptor fetching and buffer access, and optional multiplexing with GPIO (MII/RMII/SMII) or DSI/system bus signals lines (MII/RMII).
- UART with full-duplex operation up to 6.25 Mbps.
- Up to 32 general-purpose input/output (GPIO) ports.
- I<sup>2</sup>C interface that allows booting from EEPROM devices.
- Two timer modules, each with sixteen configurable 16-bit timers.
- Eight programmable hardware semaphores.
- Global interrupt controller (GIC) with interrupt consolidation and routing to  $\overline{INT\_OUT}$ ,  $\overline{NMI\_OUT}$ , and the cores; twenty-four virtual maskable interrupts (8 per core) and three virtual  $\overline{NMI}$  (one per core) that can be generated by a simple write access.
- Optional booting external memory, external host, UART, TDM, or I<sup>2</sup>C.

# Table of Contents

1	Pin Assignments	4
1.1	FC-PBGA Ball Layout Diagrams	4
1.2	Signal List By Ball Location	7
2	Electrical Characteristics	13
2.1	Maximum Ratings	13
2.2	Recommended Operating Conditions	14
2.3	Thermal Characteristics	14
2.4	DC Electrical Characteristics	14
2.5	AC Timings	16
3	Hardware Design Considerations	38
3.1	Start-up Sequencing Recommendations	38
3.2	Power Supply Design Considerations	38
3.3	Connectivity Guidelines	39
3.4	External SDRAM Selection	40
3.5	Thermal Considerations	41
4	Ordering Information	41
5	Package Information	42
6	Product Documentation	42
7	Revision History	43

## List of Figures

Figure 1.	MSC8113 Block Diagram	3
Figure 2.	StarCore® SC140 DSP Extended Core Block Diagram	3
Figure 3.	MSC8113 Package, Top View	5
Figure 4.	MSC8113 Package, Bottom View	6
Figure 5.	Overshoot/Undershoot Voltage for $V_{IH}$ and $V_{IL}$	15
Figure 6.	Start-Up Sequence: $V_{DD}$ and $V_{DDH}$ Raised Together	16
Figure 7.	Start-Up Sequence: $V_{DD}$ Raised Before $V_{DDH}$ with CLKIN Started with $V_{DDH}$	17
Figure 8.	Power-Up Sequence for $V_{DDH}$ and $V_{DD}/V_{CCSYN}$	17
Figure 9.	Timing Diagram for a Reset Configuration Write	21

Figure 10.	Internal Tick Spacing for Memory Controller Signals	21
Figure 11.	SIU Timing Diagram	24
Figure 12.	CLKOUT and CLKIN Signals	25
Figure 13.	DMA Signals	26
Figure 14.	Asynchronous Single- and Dual-Strobe Modes Read Timing Diagram	27
Figure 15.	Asynchronous Single- and Dual-Strobe Modes Write Timing Diagram	28
Figure 16.	Asynchronous Broadcast Write Timing Diagram	28
Figure 17.	DSI Synchronous Mode Signals Timing Diagram	30
Figure 18.	TDM Inputs Signals	31
Figure 19.	TDM Output Signals	31
Figure 20.	UART Input Timing	32
Figure 21.	UART Output Timing	32
Figure 22.	Timer Timing	33
Figure 23.	MDIO Timing Relationship to MDC	33
Figure 24.	MII Mode Signal Timing	34
Figure 25.	RMII Mode Signal Timing	34
Figure 26.	SMII Mode Signal Timing	35
Figure 27.	GPIO Timing	35
Figure 28.	EE Pin Timing	36
Figure 29.	Test Clock Input Timing Diagram	37
Figure 30.	Boundary Scan (JTAG) Timing Diagram	37
Figure 31.	Test Access Port Timing Diagram	37
Figure 32.	TRST Timing Diagram	37
Figure 33.	Core Power Supply Decoupling	38
Figure 34.	$V_{CCSYN}$ Bypass	39
Figure 35.	MSC8113 Mechanical Information, 431-pin FC-PBGA Package	42

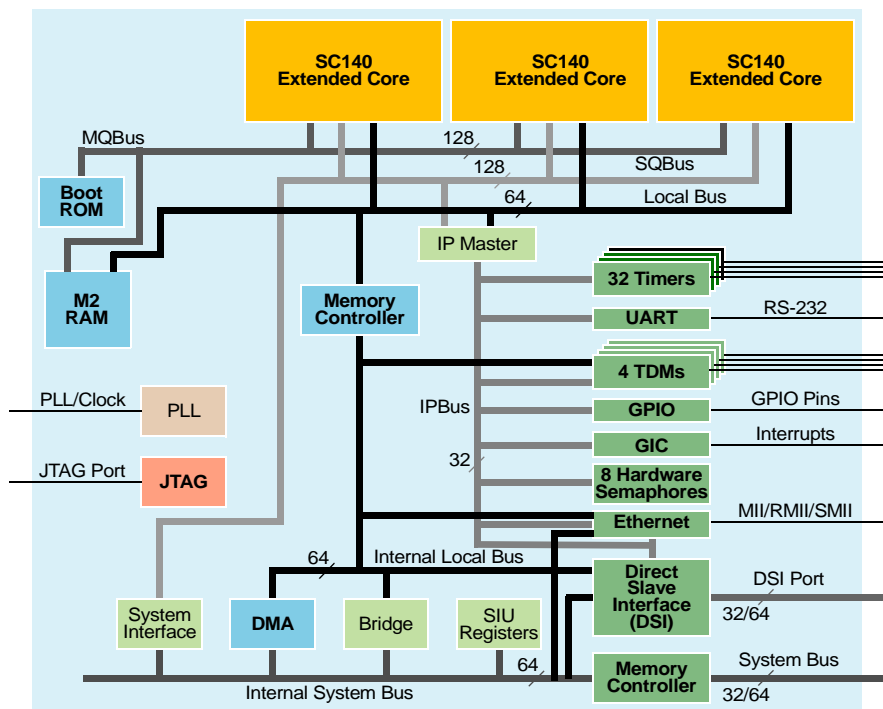
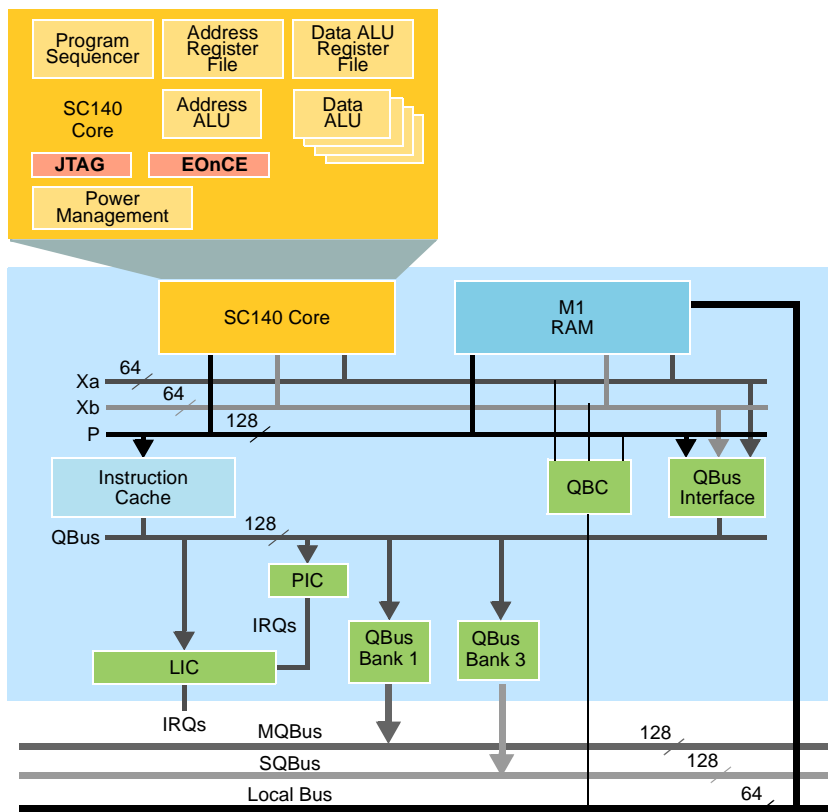

Figure 1. MSC8113 Block Diagram



Notes: 1. The arrows show the data transfer direction.  
 2. The QBus interface includes a bus switch, write buffer, fetch unit, and a control unit that defines four QBus banks. In addition, the QBC handles internal memory contentions.

Figure 2. StarCore® SC140 DSP Extended Core Block Diagram

# 1 Pin Assignments

This section includes diagrams of the MSC8113 package ball grid array layouts and pinout allocation tables.

## 1.1 FC-PBGA Ball Layout Diagrams

Top and bottom views of the FC-PBGA package are shown in **Figure 3** and **Figure 4** with their ball location index numbers.

Top View

	2	3	4	5	6	7	8	9	10	11	12	13	14	15	16	17	18	19	20	21	22	
B		V <sub>DD</sub>	GND	GND	NMI OUT	GND	V <sub>DD</sub>	GND	V <sub>DD</sub>	GND	V <sub>DD</sub>	GND	V <sub>DD</sub>	GND	V <sub>DD</sub>	GND	V <sub>DD</sub>	GPI00	V <sub>DD</sub>	V <sub>DD</sub>	GND	
C	GND	V <sub>DD</sub>	TDO	S RESET	GPI028	HCID1	GND	V <sub>DD</sub>	GND	V <sub>DD</sub>	GND	V <sub>DD</sub>	GND	GND	GPI030	GPI02	GPI01	GPI07	GPI03	GPI05	GPI06	
D	TDI	EE0	EE1	GND	V <sub>DDH</sub>	HCID2	HCID3	GND	V <sub>DD</sub>	GND	V <sub>DD</sub>	GND	V <sub>DD</sub>	V <sub>DD</sub>	GPI031	GPI029	V <sub>DDH</sub>	GPI04	V <sub>DDH</sub>	GND	GPI08	
E	TCK	TRST	TMS	HRESET	GPI027	HCID0	GND	V <sub>DD</sub>	GND	V <sub>DD</sub>	GND	V <sub>DD</sub>	GND	GND	V <sub>DD</sub>	GND	GND	GPI09	GPI013	GPI010	GPI012	
F	PO RESET	RST CONF	NMI	HA29	HA22	GND	V <sub>DD</sub>	V <sub>DD</sub>	V <sub>DD</sub>	GND	V <sub>DD</sub>	GND	V <sub>DD</sub>	ETHRX CLK	ETHTX CLK	GPI020	GPI018	GPI016	GPI011	GPI014	GPI019	
G	HA24	HA27	HA25	HA23	HA17	PWE0	V <sub>DD</sub>	V <sub>DD</sub>	BADDR 31	BM0	ABB	V <sub>DD</sub>	INT OUT	ETHCR S	V <sub>DD</sub>	CS1	BCTL0	GPI015	GND	GPI017	GPI022	
H	HA20	HA28	V <sub>DD</sub>	HA19	TEST	PSD CAS	PGTA	V <sub>DD</sub>	BM1	ARTRY	AACK	DBB	HTA	V <sub>DD</sub>	TT4	CS4	GPI024	GPI021	V <sub>DD</sub>	V <sub>DDH</sub>	A31	
J	HA18	HA26	V <sub>DD</sub>	HA13	GND	PSDA MUX	BADDR 27	V <sub>DD</sub>	CLKIN	BM2	DBG	V <sub>DD</sub>	GND	V <sub>DD</sub>	TT3	PSDA10	BCTL1	GPI023	GND	GPI025	A30	
K	HA15	HA21	HA16	PWE3	PWE1	POE	BADDR 30	Res.	GND	GND	GND	GND	CLKOUT	V <sub>DD</sub>	TT2	ALE	CS2	GND	A26	A29	A28	
L	HA12	HA14	HA11	V <sub>DDH</sub>	V <sub>DDH</sub>	BADDR 28	BADDR 29	GND	GND	<b>MSC8113</b>				GND	V <sub>DDH</sub>	GND	GND	CS3	V <sub>DDH</sub>	A27	A25	A22
M	HD28	HD31	V <sub>DDH</sub>	GND	GND	GND	V <sub>DD</sub>	V <sub>DDH</sub>	GND					GND	V <sub>DDH</sub>	GND	GND	V <sub>DDH</sub>	H RST	V <sub>DDH</sub>	V <sub>DDH</sub>	GND
N	HD26	HD30	HD29	HD24	PWE2	V <sub>DDH</sub>	HWBS 0	HBCS	GND	<b>MSC8113</b>				GND	HRDS	BG	HCS	CS0	PSDWE	GPI026	A23	A20
P	HD20	HD27	HD25	HD23	HWBS 3	HWBS 2	HWBS 1	HCLKIN	GND					GND <sub>SYN</sub>	V <sub>CCSYN</sub>	GND	GND	TA	BR	TEA	PSD VAL	DP0
R	HD18	V <sub>DDH</sub>	GND	HD22	HWBS 6	HWBS 4	TSZ1	TSZ3	GBL	V <sub>DD</sub>	V <sub>DD</sub>	V <sub>DD</sub>	TT0	DP7	DP6	DP3	TS	DP2	A17	A18	A16	
T	HD17	HD21	HD1	HD0	HWBS 7	HWBS 5	TSZ0	TSZ2	TBST	V <sub>DD</sub>	D16	TT1	D21	D23	DP5	DP4	DP1	D30	GND	A15	A14	
U	HD16	HD19	HD2	D2	D3	D6	D8	D9	D11	D14	D15	D17	D19	D22	D25	D26	D28	D31	V <sub>DDH</sub>	A12	A13	
V	HD3	V <sub>DDH</sub>	GND	D0	D1	D4	D5	D7	D10	D12	D13	D18	D20	GND	D24	D27	D29	A8	A9	A10	A11	
W	HD6	HD5	HD4	GND	GND	V <sub>DDH</sub>	V <sub>DDH</sub>	GND	HDST1	HDST0	V <sub>DDH</sub>	GND	HD40	V <sub>DDH</sub>	HD33	V <sub>DDH</sub>	HD32	GND	GND	A7	A6	
Y	HD7	HD15	V <sub>DDH</sub>	HD9	V <sub>DD</sub>	HD60	HD58	GND	V <sub>DDH</sub>	HD51	GND	V <sub>DDH</sub>	HD43	GND	V <sub>DDH</sub>	GND	HD37	HD34	V <sub>DDH</sub>	A4	A5	
AA	V <sub>DD</sub>	HD14	HD12	HD10	HD63	HD59	GND	V <sub>DDH</sub>	HD54	HD52	V <sub>DDH</sub>	GND	V <sub>DDH</sub>	HD46	GND	HD42	HD38	HD35	A0	A2	A3	
AB	GND	HD13	HD11	HD8	HD62	HD61	HD57	HD56	HD55	HD53	HD50	HD49	HD48	HD47	HD45	HD44	HD41	HD39	HD36	A1	V <sub>DD</sub>	

Figure 3. MSC8113 Package, Top View

Bottom View

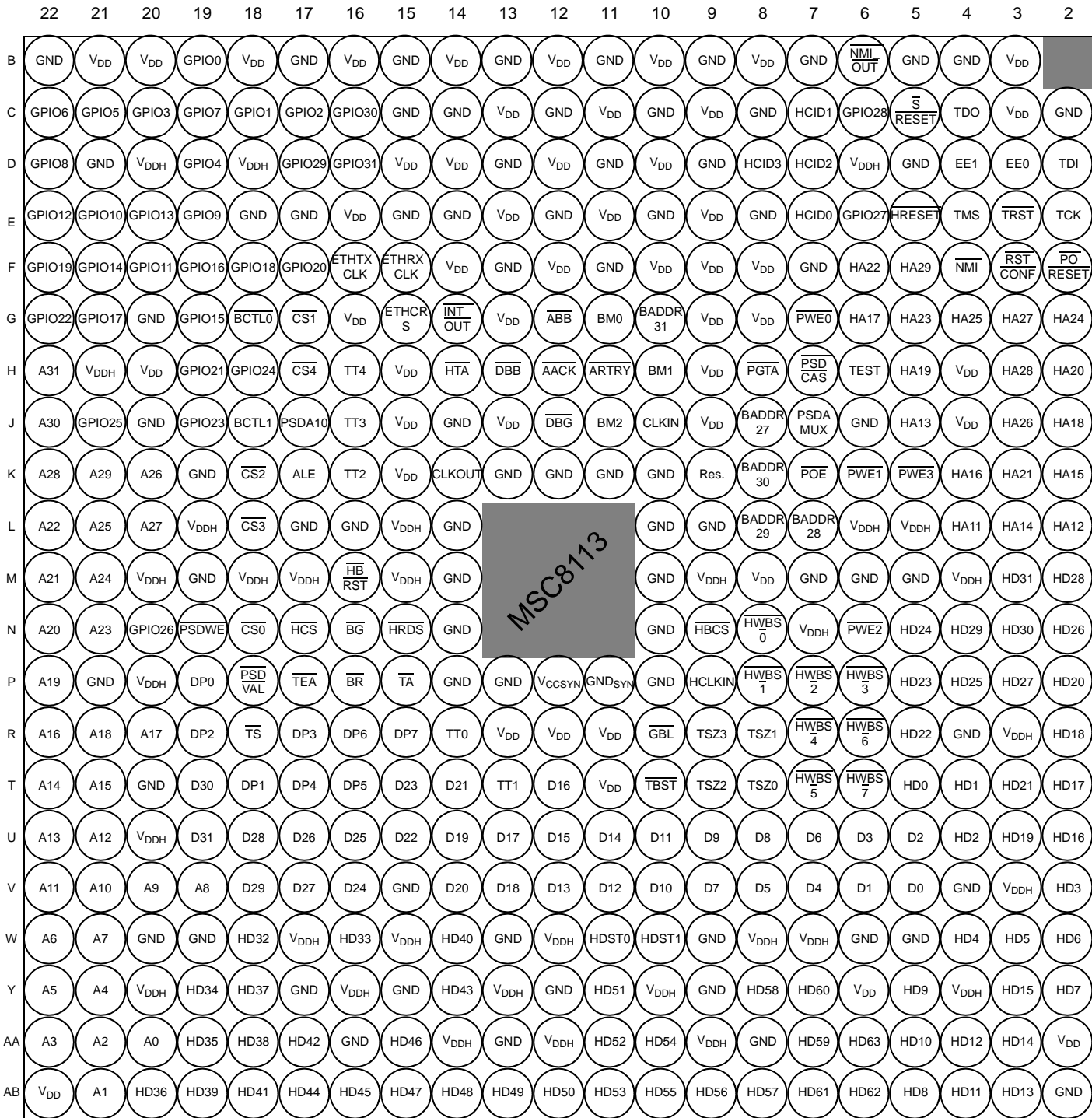

Figure 4. MSC8113 Package, Bottom View

## 1.2 Signal List By Ball Location

Table 1 presents signal list sorted by ball number. -

**Table 1. MSC8113 Signal Listing by Ball Designator**

Des.	Signal Name	Des.	Signal Name
B3	V <sub>DD</sub>	C18	GPIO1/TIMER0/CHIP_ID1/ $\overline{\text{IRQ5}}$ /ETHTXD1
B4	GND	C19	GPIO7/TDM3RCLK/ $\overline{\text{IRQ5}}$ /ETHTXD3
B5	GND	C20	GPIO3/TDM3TSYN/ $\overline{\text{IRQ1}}$ /ETHTXD2
B6	$\overline{\text{NMI\_OUT}}$	C21	GPIO5/TDM3TDAT/ $\overline{\text{IRQ3}}$ /ETHRXD3
B7	GND	C22	GPIO6/TDM3RSYN/ $\overline{\text{IRQ4}}$ /ETHRXD2
B8	V <sub>DD</sub>	D2	TDI
B9	GND	D3	EE0
B10	V <sub>DD</sub>	D4	EE1
B11	GND	D5	GND
B12	V <sub>DD</sub>	D6	V <sub>DDH</sub>
B13	GND	D7	HCID2
B14	V <sub>DD</sub>	D8	HCID3/HA8
B15	GND	D9	GND
B16	V <sub>DD</sub>	D10	V <sub>DD</sub>
B17	GND	D11	GND
B18	V <sub>DD</sub>	D12	V <sub>DD</sub>
B19	GPIO0/CHIP_ID0/ $\overline{\text{IRQ4}}$ /ETHTXD0	D13	GND
B20	V <sub>DD</sub>	D14	V <sub>DD</sub>
B21	V <sub>DD</sub>	D15	V <sub>DD</sub>
B22	GND	D16	GPIO31/TIMER3/SCL
C2	GND	D17	GPIO29/CHIP_ID3/ETHTX_EN
C3	V <sub>DD</sub>	D18	V <sub>DDH</sub>
C4	TDO	D19	GPIO4/TDM3TCLK/ $\overline{\text{IRQ2}}$ /ETHTX_ER
C5	$\overline{\text{SRESET}}$	D20	V <sub>DDH</sub>
C6	GPIO28/UTXD/DREQ2	D21	GND
C7	HCID1	D22	GPIO8/TDM3RDAT/ $\overline{\text{IRQ6}}$ /ETHCOL
C8	GND	E2	TCK
C9	V <sub>DD</sub>	E3	$\overline{\text{TRST}}$
C10	GND	E4	TMS
C11	V <sub>DD</sub>	E5	$\overline{\text{HRESET}}$
C12	GND	E6	GPIO27/URXD/DREQ1
C13	V <sub>DD</sub>	E7	HCID0
C14	GND	E8	GND
C15	GND	E9	V <sub>DD</sub>
C16	GPIO30/TIMER2/TMCLK/SDA	E10	GND
C17	GPIO2/TIMER1/CHIP_ID2/ $\overline{\text{IRQ6}}$	E11	V <sub>DD</sub>

**Table 1. MSC8113 Signal Listing by Ball Designator (continued)**

Des.	Signal Name	Des.	Signal Name
E12	GND	G6	HA17
E13	V <sub>DD</sub>	G7	PWE0/PSDDQM0/PBS0
E14	GND	G8	V <sub>DD</sub>
E15	GND	G9	V <sub>DD</sub>
E16	V <sub>DD</sub>	G10	IRQ3/BADDR31
E17	GND	G11	BM0/TC0/BNKSEL0
E18	GND	G12	ABB/IRQ4
E19	GPIO9/TDM2TSYN/IRQ7/ETHMDIO	G13	V <sub>DD</sub>
E20	GPIO13/TDM2RCLK/IRQ11/ETHMDC	G14	IRQ7/INT_OUT
E21	GPIO10/TDM2TCLK/IRQ8/ETHRX_DV/ETHCRS_DV/NC	G15	ETHCRS/ETHRXD
E22	GPIO12/TDM2RSYN/IRQ10/ETHRXD1/ETHSYNC	G16	V <sub>DD</sub>
F2	PORESET	G17	CS1
F3	RSTCONF	G18	BCTL0
F4	NMI	G19	GPIO15/TDM1TSYN/DREQ1
F5	HA29	G20	GND
F6	HA22	G21	GPIO17/TDM1TDAT/DACK1
F7	GND	G22	GPIO22/TDM0TCLK/DONE2/DRACK2
F8	V <sub>DD</sub>	H2	HA20
F9	V <sub>DD</sub>	H3	HA28
F10	V <sub>DD</sub>	H4	V <sub>DD</sub>
F11	GND	H5	HA19
F12	V <sub>DD</sub>	H6	TEST
F13	GND	H7	PSDCAS/PGPL3
F14	V <sub>DD</sub>	H8	PGTA/PUPMWAIT/PGPL4/PPBS
F15	ETHRX_CLK/ETHSYNC_IN	H9	V <sub>DD</sub>
F16	ETHTX_CLK/ETHREF_CLK/ETHCLOCK	H10	BM1/TC1/BNKSEL1
F17	GPIO20/TDM1RDAT	H11	ARTRY
F18	GPIO18/TDM1RSYN/DREQ2	H12	AACK
F19	GPIO16/TDM1TCLK/DONE1/DRACK1	H13	DBB/IRQ5
F20	GPIO11/TDM2TDAT/IRQ9/ETHRX_ER/ETHTXD	H14	HTA
F21	GPIO14/TDM2RDAT/IRQ12/ETHRXD0/NC	H15	V <sub>DD</sub>
F22	GPIO19/TDM1RCLK/DACK2	H16	TT4/CS7
G2	HA24	H17	CS4
G3	HA27	H18	GPIO24/TDM0RSYN/IRQ14
G4	HA25	H19	GPIO21/TDM0TSYN
G5	HA23	H20	V <sub>DD</sub>

Table 1. MSC8113 Signal Listing by Ball Designator (continued)

Des.	Signal Name	Des.	Signal Name
H21	V <sub>DDH</sub>	K15	V <sub>DD</sub>
H22	A31	K16	TT2/ $\overline{\text{CS5}}$
J2	HA18	K17	ALE
J3	HA26	K18	$\overline{\text{CS2}}$
J4	V <sub>DD</sub>	K19	GND
J5	HA13	K20	A26
J6	GND	K21	A29
J7	PSDAMUX/PGPL5	K22	A28
J8	BADDR27	L2	HA12
J9	V <sub>DD</sub>	L3	HA14
J10	CLKIN	L4	HA11
J11	BM2/TC2/BNKSEL2	L5	V <sub>DDH</sub>
J12	$\overline{\text{DBG}}$	L6	V <sub>DDH</sub>
J13	V <sub>DD</sub>	L7	BADDR28
J14	GND	L8	$\overline{\text{IRQ5}}$ /BADDR29
J15	V <sub>DD</sub>	L9	GND
J16	TT3/ $\overline{\text{CS6}}$	L10	GND
J17	PSDA10/PGPL0	L14	GND
J18	$\overline{\text{BCTL1}}$ / $\overline{\text{CS5}}$	L15	V <sub>DDH</sub>
J19	GPIO23/TDM0TDAT/ $\overline{\text{IRQ13}}$	L16	GND
J20	GND	L17	GND
J21	GPIO25/TDM0RCLK/ $\overline{\text{IRQ15}}$	L18	$\overline{\text{CS3}}$
J22	A30	L19	V <sub>DDH</sub>
K2	HA15	L20	A27
K3	HA21	L21	A25
K4	HA16	L22	A22
K5	$\overline{\text{PWE3}}$ / $\overline{\text{PSDDQM3}}$ / $\overline{\text{PBS3}}$	M2	HD28
K6	$\overline{\text{PWE1}}$ / $\overline{\text{PSDDQM1}}$ / $\overline{\text{PBS1}}$	M3	HD31
K7	$\overline{\text{POE}}$ / $\overline{\text{PSDRAS}}$ /PGPL2	M4	V <sub>DDH</sub>
K8	$\overline{\text{IRQ2}}$ /BADDR30	M5	GND
K9	Reserved	M6	GND
K10	GND	M7	GND
K11	GND	M8	V <sub>DD</sub>
K12	GND	M9	V <sub>DDH</sub>
K13	GND	M10	GND
K14	CLKOUT	M14	GND

Table 1. MSC8113 Signal Listing by Ball Designator (continued)

Des.	Signal Name	Des.	Signal Name
M15	V <sub>DDH</sub>	P12	V <sub>CCSYN</sub>
M16	$\overline{\text{HBRST}}$	P13	GND
M17	V <sub>DDH</sub>	P14	GND
M18	V <sub>DDH</sub>	P15	$\overline{\text{TA}}$
M19	GND	P16	$\overline{\text{BR}}$
M20	V <sub>DDH</sub>	P17	$\overline{\text{TEA}}$
M21	A24	P18	$\overline{\text{PSDVAL}}$
M22	A21	P19	DP0/DREQ1/EXT_BR2
N2	HD26	P20	V <sub>DDH</sub>
N3	HD30	P21	GND
N4	HD29	P22	A19
N5	HD24	R2	HD18
N6	$\overline{\text{PWE2/PSDDQM2/PBS2}}$	R3	V <sub>DDH</sub>
N7	V <sub>DDH</sub>	R4	GND
N8	$\overline{\text{HWBS0/HDBS0/HWBE0/HDBE0}}$	R5	HD22
N9	$\overline{\text{HBCS}}$	R6	$\overline{\text{HWBS6/HDBS6/HWBE6/HDBE6/PWE6/PSDDQM6/PBS6}}$
N10	GND	R7	$\overline{\text{HWBS4/HDBS4/HWBE4/HDBE4/PWE4/PSDDQM4/PBS4}}$
N14	GND	R8	TSZ1
N15	$\overline{\text{HRDS/HRW/HRDE}}$	R9	TSZ3
N16	$\overline{\text{BG}}$	R10	$\overline{\text{IRQ1/GBL}}$
N17	$\overline{\text{HCS}}$	R11	V <sub>DD</sub>
N18	$\overline{\text{CS0}}$	R12	V <sub>DD</sub>
N19	$\overline{\text{PSDWE/PGPL1}}$	R13	V <sub>DD</sub>
N20	GPIO26/TDM0RDAT	R14	TT0/HA7
N21	A23	R15	$\overline{\text{IRQ7/DP7/DREQ4}}$
N22	A20	R16	$\overline{\text{IRQ6/DP6/DREQ3}}$
P2	HD20	R17	$\overline{\text{IRQ3/DP3/DREQ2/EXT_BR3}}$
P3	HD27	R18	$\overline{\text{TS}}$
P4	HD25	R19	$\overline{\text{IRQ2/DP2/DACK2/EXT_DBG2}}$
P5	HD23	R20	A17
P6	$\overline{\text{HWBS3/HDBS3/HWBE3/HDBE3}}$	R21	A18
P7	$\overline{\text{HWBS2/HDBS2/HWBE2/HDBE2}}$	R22	A16
P8	$\overline{\text{HWBS1/HDBS1/HWBE1/HDBE1}}$	T2	HD17
P9	HCLKIN	T3	HD21
P10	GND	T4	HD1/DSISYNC
P11	GND <sub>SYN</sub>	T5	HD0/SWTE

Table 1. MSC8113 Signal Listing by Ball Designator (continued)

Des.	Signal Name	Des.	Signal Name
T6	$\overline{\text{HWBS7/HDBS7/HWBE7/HDBE7/PWE7/PSDDQM7/PBS7}}$	U21	A12
T7	$\overline{\text{HWBS5/HDBS5/HWBE5/HDBE5/PWE5/PSDDQM5/PBS5}}$	U22	A13
T8	TSZ0	V2	HD3/MODCK1
T9	TSZ2	V3	V <sub>DDH</sub>
T10	$\overline{\text{TBST}}$	V4	GND
T11	V <sub>DD</sub>	V5	D0
T12	D16	V6	D1
T13	TT1	V7	D4
T14	D21	V8	D5
T15	D23	V9	D7
T16	$\overline{\text{IRQ5/DP5/DACK4/EXT_BG3}}$	V10	D10
T17	$\overline{\text{IRQ4/DP4/DACK3/EXT_DBG3}}$	V11	D12
T18	$\overline{\text{IRQ1/DP1/DACK1/EXT_BG2}}$	V12	D13
T19	D30	V13	D18
T20	GND	V14	D20
T21	A15	V15	GND
T22	A14	V16	D24
U2	HD16	V17	D27
U3	HD19	V18	D29
U4	HD2/DSI64	V19	A8
U5	D2	V20	A9
U6	D3	V21	A10
U7	D6	V22	A11
U8	D8	W2	HD6
U9	D9	W3	HD5/CNFGS
U10	D11	W4	HD4/MODCK2
U11	D14	W5	GND
U12	D15	W6	GND
U13	D17	W7	V <sub>DDH</sub>
U14	D19	W8	V <sub>DDH</sub>
U15	D22	W9	GND
U16	D25	W10	HDST1/HA10
U17	D26	W11	HDST0/HA9
U18	D28	W12	V <sub>DDH</sub>
U19	D31	W13	GND
U20	V <sub>DDH</sub>	W14	HD40/D40/ETHRXD0

**Table 1. MSC8113 Signal Listing by Ball Designator (continued)**

Des.	Signal Name	Des.	Signal Name
W15	V <sub>DDH</sub>	AA9	V <sub>DDH</sub>
W16	HD33/D33/reserved	AA10	HD54/D54/ETHTX_EN
W17	V <sub>DDH</sub>	AA11	HD52/D52
W18	HD32/D32/reserved	AA12	V <sub>DDH</sub>
W19	GND	AA13	GND
W20	GND	AA14	V <sub>DDH</sub>
W21	A7	AA15	HD46/D46/ETHTXT0
W22	A6	AA16	GND
Y2	HD7	AA17	HD42/D42/ETHRXD2/reserved
Y3	HD15	AA18	HD38/D38/reserved
Y4	V <sub>DDH</sub>	AA19	HD35/D35/reserved
Y5	HD9	AA20	A0
Y6	V <sub>DD</sub>	AA21	A2
Y7	HD60/D60/ETHCOL/reserved	AA22	A3
Y8	HD58/D58/ETHMDC	AB2	GND
Y9	GND	AB3	HD13
Y10	V <sub>DDH</sub>	AB4	HD11
Y11	HD51/D51	AB5	HD8
Y12	GND	AB6	HD62/D62
Y13	V <sub>DDH</sub>	AB7	HD61/D61
Y14	HD43/D43/ETHRXD3/reserved	AB8	HD57/D57/ETHRX_ER
Y15	GND	AB9	HD56/D56/ETHRX_DV/ETHCRS_DV
Y16	V <sub>DDH</sub>	AB10	HD55/D55/ETHTX_ER/reserved
Y17	GND	AB11	HD53/D53
Y18	HD37/D37/reserved	AB12	HD50/D50
Y19	HD34/D34/reserved	AB13	HD49/D49/ETHTXD3/reserved
Y20	V <sub>DDH</sub>	AB14	HD48/D48/ETHTXD2/reserved
Y21	A4	AB15	HD47/D47/ETHTXD1
Y22	A5	AB16	HD45/D45
AA2	V <sub>DD</sub>	AB17	HD44/D44
AA3	HD14	AB18	HD41/D41/ETHRXD1
AA4	HD12	AB19	HD39/D39/reserved
AA5	HD10	AB20	HD36/D36/reserved
AA6	HD63/D63	AB21	A1
AA7	HD59/D59/ETHMDIO	AB22	V <sub>DD</sub>
AA8	GND		

## 2 Electrical Characteristics

This document contains detailed information on power considerations, DC/AC electrical characteristics, and AC timing specifications. For additional information, see the *MSC8113 Reference Manual*.

### 2.1 Maximum Ratings

#### CAUTION

**This device contains circuitry protecting against damage due to high static voltage or electrical fields; however, normal precautions should be taken to avoid exceeding maximum voltage ratings. Reliability is enhanced if unused inputs are tied to an appropriate logic voltage level (for example, either GND or  $V_{DD}$ ).**

In calculating timing requirements, adding a maximum value of one specification to a minimum value of another specification does not yield a reasonable sum. A maximum specification is calculated using a worst case variation of process parameter values in one direction. The minimum specification is calculated using the worst case for the same parameters in the opposite direction. Therefore, a “maximum” value for a specification never occurs in the same device with a “minimum” value for another specification; adding a maximum to a minimum represents a condition that can never exist.

**Table 2** describes the maximum electrical ratings for the MSC8113.

**Table 2. Absolute Maximum Ratings**

Rating	Symbol	Value	Unit
Core and PLL supply voltage	$V_{DD}$	-0.2 to 1.6	V
I/O supply voltage	$V_{DDH}$	-0.2 to 4.0	V
Input voltage	$V_{IN}$	-0.2 to 4.0	V
Maximum operating temperature:	$T_J$	105	°C
Minimum operating temperature	$T_J$	-40	°C
Storage temperature range	$T_{STG}$	-55 to +150	°C
<b>Notes:</b>	<ol style="list-style-type: none"> <li>1. Functional operating conditions are given in <b>Table 3</b>.</li> <li>2. Absolute maximum ratings are stress ratings only, and functional operation at the maximum is not guaranteed. Stress beyond the listed limits may affect device reliability or cause permanent damage.</li> <li>3. <b>Section 3.5, Thermal Considerations</b> includes a formula for computing the chip junction temperature (<math>T_J</math>).</li> </ol>		

## 2.2 Recommended Operating Conditions

Table 3 lists recommended operating conditions. Proper device operation outside of these conditions is not guaranteed.

Table 3. Recommended Operating Conditions

Rating	Symbol	Value	Unit
Core and PLL supply voltage:	$V_{DD}$ $V_{CCSYN}$	1.07 to 1.13	V
I/O supply voltage	$V_{DDH}$	3.135 to 3.465	V
Input voltage	$V_{IN}$	-0.2 to $V_{DDH}+0.2$	V
Operating temperature range:	$T_J$	-40 to 105	°C

## 2.3 Thermal Characteristics

Table 4 describes thermal characteristics of the MSC8113 for the FC-PBGA packages.

Table 4. Thermal Characteristics for the MSC8113

Characteristic	Symbol	FC-PBGA 20 × 20 mm <sup>5</sup>		Unit
		Natural Convection	200 ft/min (1 m/s) airflow	
Junction-to-ambient <sup>1, 2</sup>	$R_{\theta JA}$	26	21	°C/W
Junction-to-ambient, four-layer board <sup>1, 3</sup>	$R_{\theta JA}$	19	15	°C/W
Junction-to-board (bottom) <sup>4</sup>	$R_{\theta JB}$	9		°C/W
Junction-to-case <sup>5</sup>	$R_{\theta JC}$	0.9		°C/W
Junction-to-package-top <sup>6</sup>	$\Psi_{JT}$	1		°C/W

**Notes:**

- Junction temperature is a function of die size, on-chip power dissipation, package thermal resistance, mounting site (board) temperature, ambient temperature, air flow, power dissipation of other components on the board, and board thermal resistance.
- Per SEMI G38-87 and JEDEC JESD51-2 with the single layer board horizontal.
- Per JEDEC JESD51-6 with the board horizontal.
- Thermal resistance between the die and the printed circuit board per JEDEC JESD 51-8. Board temperature is measured on the top surface of the board near the package.
- Thermal resistance between the die and the case top surface as measured by the cold plate method (MIL SPEC-883 Method 1012.1).
- Thermal characterization parameter indicating the temperature difference between package top and the junction temperature per JEDEC JESD51-2.

Section 3.5, *Thermal Considerations* provides a detailed explanation of these characteristics.

## 2.4 DC Electrical Characteristics

This section describes the DC electrical characteristics for the MSC8113. The measurements in Table 5 assume the following system conditions:

- $T_A = 25\text{ °C}$
- $V_{DD} = 1.1\text{ V nominal} = 1.07\text{--}1.13\text{ V}_{DC}$
- $V_{DDH} = 3.3\text{ V} \pm 5\% V_{DC}$
- $GND = 0\text{ V}_{DC}$

**Note:** The leakage current is measured for nominal  $V_{DDH}$  and  $V_{DD}$ .

Table 5. DC Electrical Characteristics

Characteristic	Symbol	Min	Typical	Max	Unit
Input high voltage <sup>1</sup> , all inputs except CLKIN	$V_{IH}$	2.0	—	3.465	V
Input low voltage <sup>1</sup>	$V_{IL}$	GND	0	0.8	V
CLKIN input high voltage	$V_{IHC}$	2.4	3.0	3.465	V
CLKIN input low voltage	$V_{ILC}$	GND	0	0.8	V
Input leakage current, $V_{IN} = V_{DDH}$	$I_{IN}$	-1.0	0.09	1	$\mu\text{A}$
Tri-state (high impedance off state) leakage current, $V_{IN} = V_{DDH}$	$I_{OZ}$	-1.0	0.09	1	$\mu\text{A}$
Signal low input current, $V_{IL} = 0.8 \text{ V}^2$	$I_L$	-1.0	0.09	1	$\mu\text{A}$
Signal high input current, $V_{IH} = 2.0 \text{ V}^2$	$I_H$	-1.0	0.09	1	$\mu\text{A}$
Output high voltage, $I_{OH} = -2 \text{ mA}$ , except open drain pins	$V_{OH}$	2.0	3.0	—	V
Output low voltage, $I_{OL} = 3.2 \text{ mA}$	$V_{OL}$	—	0	0.4	V
Internal supply current:					
• Wait mode	$I_{DDW}$	—	375 <sup>3</sup>	—	mA
• Stop mode	$I_{DDS}$	—	290 <sup>3</sup>	—	mA
Typical power 400 MHz at 1.1 V <sup>4</sup>	P	—	826	—	mW
Typical power 300 MHz at 1.1 V <sup>4</sup>		—	676	—	mW

**Notes:**

1. See **Figure 5** for undershoot and overshoot voltages.
2. Not tested. Guaranteed by design.
3. Measured for 1.1 V core at 25°C junction temperature.
4. The typical power values were calculated using a power calculator configured for three cores performing an EFR code with the device running at the specified operating frequency and a junction temperature of 25°C. No peripherals were included. The calculator was created using CodeWarrior® 2.5. These values are provided as examples only. Power consumption is application dependent and varies widely. To assure proper board design with regard to thermal dissipation and maintaining proper operating temperatures, evaluate power consumption for your application and use the design guidelines in **Section 3** of this document and in *MSC8102, MSC8122, and MSC8126 Thermal Management Design Guidelines (AN2601)*.

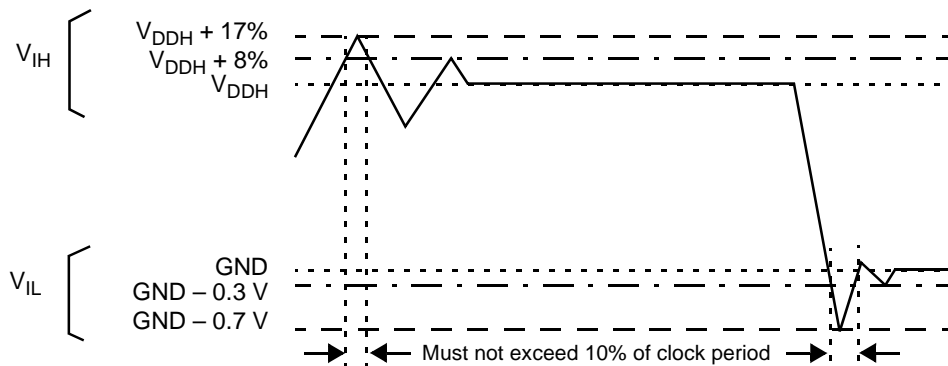
 Figure 5. Overshoot/Undershoot Voltage for  $V_{IH}$  and  $V_{IL}$

## 2.5 AC Timings

The following sections include illustrations and tables of clock diagrams, signals, and parallel I/O outputs and inputs. When systems such as DSP farms are developed using the DSI, use a device loading of 4 pF per pin. AC timings are based on a 20 pF load, except where noted otherwise, and a 50 Ω transmission line. For loads smaller than 20 pF, subtract 0.06 ns per pF down to 10 pF load. For loads larger than 20 pF, add 0.06 ns for SIU/Ethernet/DSI delay and 0.07 ns for GPIO/TDM/timer delay. When calculating overall loading, also consider additional RC delay.

### 2.5.1 Output Buffer Impedances

Table 6. Output Buffer Impedances

Output Buffers	Typical Impedance (Ω)
System bus	50
Memory controller	50
Parallel I/O	50

**Note:** These are typical values at 65°C. The impedance may vary by ±25% depending on device process and operating temperature.

### 2.5.2 Start-Up Timing

Starting the device requires coordination among several input sequences including clocking, reset, and power. **Section 2.5.3** describes the clocking characteristics. **Section 2.5.4** describes the reset and power-up characteristics. You must use the following guidelines when starting up an MSC8113 device:

- $\overline{\text{PORESET}}$  and  $\overline{\text{TRST}}$  must be asserted externally for the duration of the power-up sequence. See **Table 11** for timing.
- If possible, bring up the  $V_{\text{DD}}$  and  $V_{\text{DDH}}$  levels together. For designs with separate power supplies, bring up the  $V_{\text{DD}}$  levels and then the  $V_{\text{DDH}}$  levels (see **Figure 7**).
- CLKIN should start toggling at least 16 cycles (starting after  $V_{\text{DDH}}$  reaches its nominal level) before  $\overline{\text{PORESET}}$  deassertion to guarantee correct device operation (see **Figure 6** and **Figure 7**).
- CLKIN must not be pulled high during  $V_{\text{DDH}}$  power-up. CLKIN can toggle during this period.

The following figures show acceptable start-up sequence examples. **Figure 6** shows a sequence in which  $V_{\text{DD}}$  and  $V_{\text{DDH}}$  are raised together. **Figure 7** shows a sequence in which  $V_{\text{DDH}}$  is raised after  $V_{\text{DD}}$  and CLKIN begins to toggle as  $V_{\text{DDH}}$  rises.

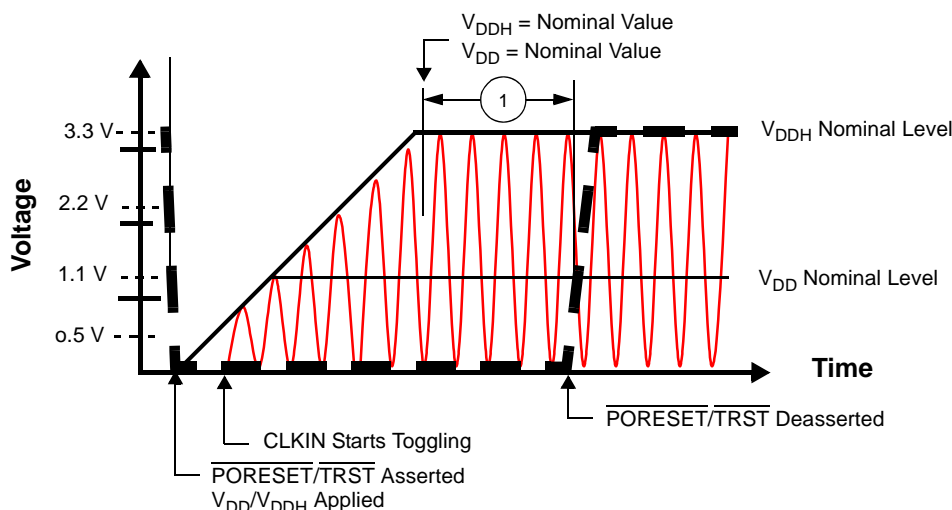
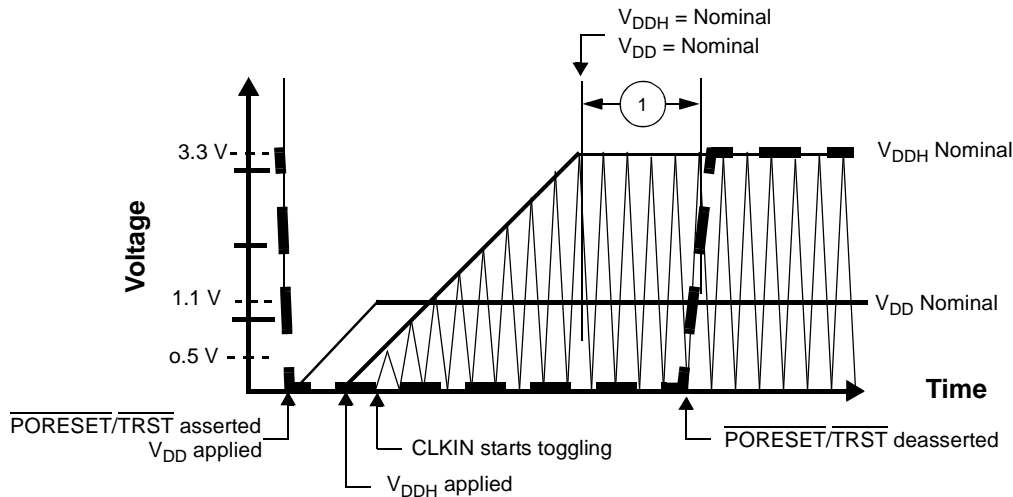
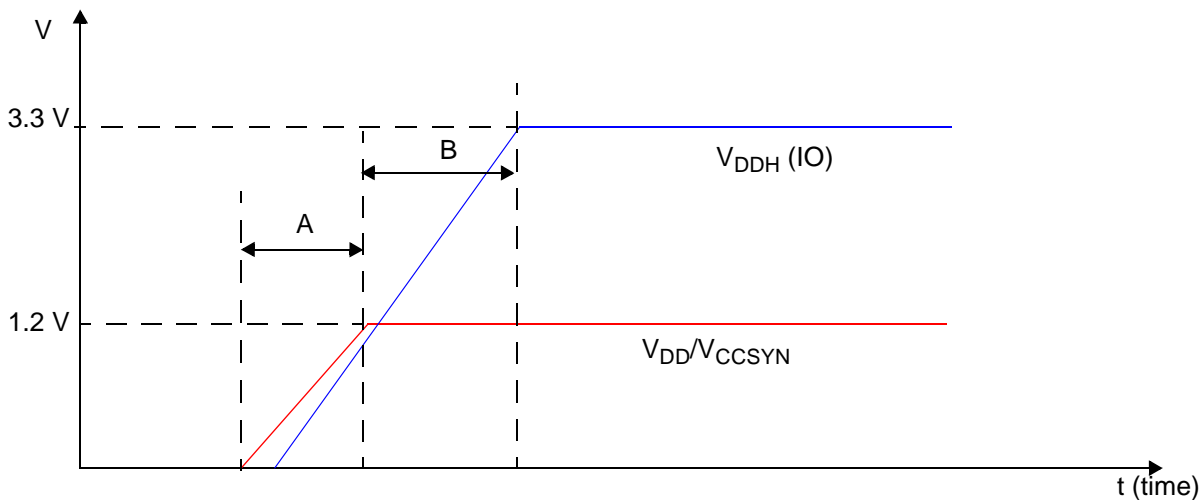

Figure 6. Start-Up Sequence:  $V_{\text{DD}}$  and  $V_{\text{DDH}}$  Raised Together



**Figure 7. Start-Up Sequence:  $V_{DD}$  Raised Before  $V_{DDH}$  with CLKIN Started with  $V_{DDH}$**

In all cases, the power-up sequence must follow the guidelines shown in **Figure 8**.



**Figure 8. Power-Up Sequence for  $V_{DDH}$  and  $V_{DD}/V_{CCSYN}$**

The following rules apply:

1. During time interval A,  $V_{DDH}$  should always be equal to or less than the  $V_{DD}/V_{CCSYN}$  voltage level. The duration of interval A should be kept below 10 ms.
2. The duration of timing interval B should be kept as small as possible and less than 10 ms.

### 2.5.3 Clock and Timing Signals

The following sections include a description of clock signal characteristics. **Table 7** shows the maximum frequency values for internal (Core, Reference, Bus, and DSI) and external (CLKIN and CLKOUT) clocks. The user must ensure that maximum frequency values are not exceeded.

**Table 7. Maximum Frequencies**

Characteristic	Maximum in MHz
Core frequency	300/400
Reference frequency (REFCLK)	100/133

**Table 7. Maximum Frequencies**

Characteristic	Maximum in MHz
Internal bus frequency (BCLK)	100/133
DSI clock frequency (HCLKIN) <ul style="list-style-type: none"> <li>Core frequency = 300 MHz</li> <li>Core frequency = 400 MHz</li> </ul>	$HCLKIN \leq (\min\{70 \text{ MHz}, CLKOUT\})$ $HCLKIN \leq (\min\{100 \text{ MHz}, CLKOUT\})$
External clock frequency (CLKIN or CLKOUT)	100/133

**Table 8. Clock Frequencies**

Characteristics	Symbol	300 MHz Device		400 MHz Device	
		Min	Max	Min	Max
CLKIN frequency	F <sub>CLKIN</sub>	20	100	20	133.3
BCLK frequency	F <sub>BCLK</sub>	40	100	40	133.3
Reference clock (REFCLK) frequency	F <sub>REFCLK</sub>	40	100	40	133.3
Output clock (CLKOUT) frequency	F <sub>CLKOUT</sub>	40	100	40	133.3
SC140 core clock frequency	F <sub>CORE</sub>	200	300	200	400
<b>Note:</b> The rise and fall time of external clocks should be 3 ns maximum					

**Table 9. System Clock Parameters**

Characteristic	Min	Max	Unit
Phase jitter between BCLK and CLKIN	—	0.3	ns
CLKIN frequency	20	see <b>Table 8</b>	MHz
CLKIN slope	—	3	ns
PLL input clock (after predivider)	20	100	MHz
PLL output frequency (VCO output) <ul style="list-style-type: none"> <li>300 MHz core</li> <li>400 MHz core</li> </ul>	800	1200 1600	MHz MHz MHz
CLKOUT frequency jitter <sup>1</sup>	—	200	ps
CLKOUT phase jitter <sup>1</sup> with CLKIN phase jitter of ±100 ps.	—	500	ps
<b>Notes:</b> <ol style="list-style-type: none"> <li>Peak-to-peak.</li> <li>Not tested. Guaranteed by design.</li> </ol>			

## 2.5.4 Reset Timing

The MSC8113 has several inputs to the reset logic:

- Power-on reset ( $\overline{PORESET}$ )
- External hard reset ( $\overline{HRESET}$ )
- External soft reset ( $\overline{SRESET}$ )
- Software watchdog reset
- Bus monitor reset
- Host reset command through JTAG

All MSC8113 reset sources are fed into the reset controller, which takes different actions depending on the source of the reset. The reset status register indicates the most recent sources to cause a reset. **Table 10** describes the reset sources.

Table 10. Reset Sources

Name	Direction	Description
Power-on reset (PORESET)	Input	Initiates the power-on reset flow that resets the MSC8113 and configures various attributes of the MSC8113. On $\overline{\text{PORESET}}$ , the entire MSC8113 device is reset. SPLL states is reset, $\overline{\text{HRESET}}$ and $\overline{\text{SRESET}}$ are driven, the SC140 extended cores are reset, and system configuration is sampled. The clock mode (MODCK bits), reset configuration mode, boot mode, Chip ID, and use of either a DSI 64 bits port or a System Bus 64 bits port are configured only when $\overline{\text{PORESET}}$ is asserted.
External hard reset ( $\overline{\text{HRESET}}$ )	Input/ Output	Initiates the hard reset flow that configures various attributes of the MSC8113. While $\overline{\text{HRESET}}$ is asserted, $\overline{\text{SRESET}}$ is also asserted. $\overline{\text{HRESET}}$ is an open-drain pin. Upon hard reset, $\overline{\text{HRESET}}$ and $\overline{\text{SRESET}}$ are driven, the SC140 extended cores are reset, and system configuration is sampled. The most configurable features are reconfigured. These features are defined in the 32-bit hard reset configuration word described in <i>Hard Reset Configuration Word</i> section of the <i>Reset</i> chapter in the <i>MSC8113 Reference Manual</i> .
External soft reset ( $\overline{\text{SRESET}}$ )	Input/ Output	Initiates the soft reset flow. The MSC8113 detects an external assertion of $\overline{\text{SRESET}}$ only if it occurs while the MSC8113 is not asserting reset. $\overline{\text{SRESET}}$ is an open-drain pin. Upon soft reset, $\overline{\text{SRESET}}$ is driven, the SC140 extended cores are reset, and system configuration is maintained.
Software watchdog reset	Internal	When the MSC8113 watchdog count reaches zero, a software watchdog reset is signalled. The enabled software watchdog event then generates an internal hard reset sequence.
Bus monitor reset	Internal	When the MSC8113 bus monitor count reaches zero, a bus monitor hard reset is asserted. The enabled bus monitor event then generates an internal hard reset sequence.
Host reset command through the TAP	Internal	When a host reset command is written through the Test Access Port (TAP), the TAP logic asserts the soft reset signal and an internal soft reset sequence is generated.

Table 11 summarizes the reset actions that occur as a result of the different reset sources.

Table 11. Reset Actions for Each Reset Source

Reset Action/Reset Source	Power-On Reset ( $\overline{\text{PORESET}}$ )	Hard Reset ( $\overline{\text{HRESET}}$ )	Soft Reset ( $\overline{\text{SRESET}}$ )	
	External only	External or Internal (Software Watchdog or Bus Monitor)	External	JTAG Command: EXTEST, CLAMP, or HIGHZ
Configuration pins sampled (Refer to Section 2.5.4.1 for details).	Yes	No	No	No
SPLL state reset	Yes	No	No	No
System reset configuration write through the DSI	Yes	No	No	No
System reset configuration write through the system bus	Yes	Yes	No	No
$\overline{\text{HRESET}}$ driven	Yes	Yes	No	No
SIU registers reset	Yes	Yes	No	No
IPBus modules reset (TDM, UART, Timers, DSI, IPBus master, GIC, HS, and GPIO)	Yes	Yes	Yes	Yes
$\overline{\text{SRESET}}$ driven	Yes	Yes	Yes	Depends on command
SC140 extended cores reset	Yes	Yes	Yes	Yes
MQBS reset	Yes	Yes	Yes	Yes

### 2.5.4.1 Power-On Reset ( $\overline{\text{PORESET}}$ ) Pin

Asserting  $\overline{\text{PORESET}}$  initiates the power-on reset flow.  $\overline{\text{PORESET}}$  must be asserted externally for at least 16 CLKIN cycles after  $V_{\text{DD}}$  and  $V_{\text{DDH}}$  are both at their nominal levels.

### 2.5.4.2 Reset Configuration

The MSC8113 has two mechanisms for writing the reset configuration:

- Through the direct slave interface (DSI)
- Through the system bus. When the reset configuration is written through the system bus, the MSC8113 acts as a configuration master or a configuration slave. If configuration slave is selected, but no special configuration word is written, a default configuration word is applied.

Fourteen signal levels (see **Chapter 1** for signal description details) are sampled on  $\overline{\text{PORESET}}$  deassertion to define the Reset Configuration Mode and boot and operating conditions:

- $\overline{\text{RSTCONF}}$
- CNFGS
- DSISYNC
- DSI64
- CHIP\_ID[0–3]
- BM[0–2]
- SWTE
- MODCK[1–2]

### 2.5.4.3 Reset Timing Tables

**Table 12** and **Figure 9** describe the reset timing for a reset configuration write through the direct slave interface (DSI) or through the system bus.

**Table 12. Timing for a Reset Configuration Write through the DSI or System Bus**

No.	Characteristics	Expression	Min	Max	Unit
1	Required external $\overline{\text{PORESET}}$ duration minimum <ul style="list-style-type: none"> <li>• CLKIN = 20 MHz</li> <li>• CLKIN = 100 MHz (300 MHz core)</li> <li>• CLKIN = 133 MHz (400 MHz core)</li> </ul>	16/CLKIN	800 160 120	— — —	ns ns ns
2	Delay from deassertion of external $\overline{\text{PORESET}}$ to deassertion of internal $\overline{\text{PORESET}}$ <ul style="list-style-type: none"> <li>• CLKIN = 20 MHz to 133 MHz</li> </ul>	1024/CLKIN	6.17	51.2	μs
3	Delay from de-assertion of internal $\overline{\text{PORESET}}$ to SPLL lock <ul style="list-style-type: none"> <li>• CLKIN = 20 MHz (RDF = 1)</li> <li>• CLKIN = 100 MHz (RDF = 1) (300 MHz core)</li> <li>• CLKIN = 133 MHz (RDF = 2) (400 MHz core)</li> </ul>	6400/(CLKIN/RDF) (PLL reference clock-division factor)	320 64 96	320 64 96	μs μs μs
5	Delay from SPLL to $\overline{\text{HRESET}}$ deassertion <ul style="list-style-type: none"> <li>• REFCLK = 40 MHz to 133 MHz</li> </ul>	512/REFCLK	3.08	12.8	μs
6	Delay from SPLL lock to $\overline{\text{SRESET}}$ deassertion <ul style="list-style-type: none"> <li>• REFCLK = 40 MHz to 133 MHz</li> </ul>	515/REFCLK	3.10	12.88	μs
7	Setup time from assertion of $\overline{\text{RSTCONF}}$ , CNFGS, DSISYNC, DSI64, CHIP_ID[0–3], BM[0–2], SWTE, and MODCK[1–2] before deassertion of $\overline{\text{PORESET}}$		3	—	ns
8	Hold time from deassertion of $\overline{\text{PORESET}}$ to deassertion of $\overline{\text{RSTCONF}}$ , CNFGS, DSISYNC, DSI64, CHIP_ID[0–3], BM[0–2], SWTE, and MODCK[1–2]		5	—	ns
<b>Note:</b>	Timings are not tested, but are guaranteed by design.				

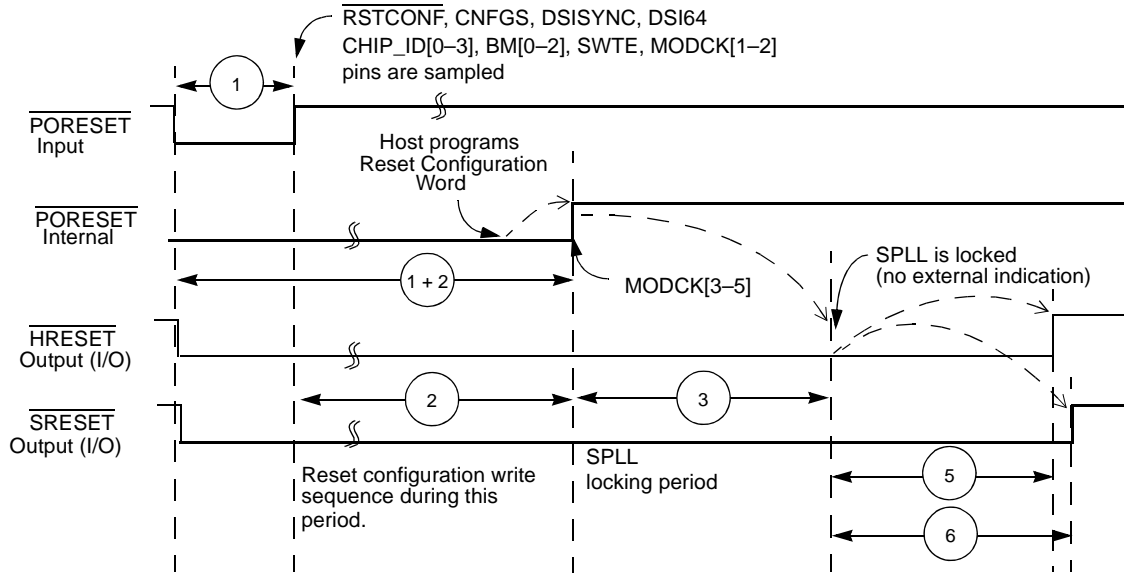

Figure 9. Timing Diagram for a Reset Configuration Write

## 2.5.5 System Bus Access Timing

### 2.5.5.1 Core Data Transfers

Generally, all MSC8113 bus and system output signals are driven from the rising edge of the reference clock (REFCLK). The REFCLK is the CLKIN signal. Memory controller signals, however, trigger on four points within a REFCLK cycle. Each cycle is divided by four internal ticks: T1, T2, T3, and T4. T1 always occurs at the rising edge of REFCLK (and T3 at the falling edge), but the spacing of T2 and T4 depends on the PLL clock ratio selected, as **Table 13** shows.

Table 13. Tick Spacing for Memory Controller Signals

BCLK/SC140 clock	Tick Spacing (T1 Occurs at the Rising Edge of REFCLK)		
	T2	T3	T4
1:4, 1:6, 1:8, 1:10	1/4 REFCLK	1/2 REFCLK	3/4 REFCLK
1:3	1/6 REFCLK	1/2 REFCLK	4/6 REFCLK
1:5	2/10 REFCLK	1/2 REFCLK	7/10 REFCLK

Figure 10 is a graphical representation of **Table 13**.

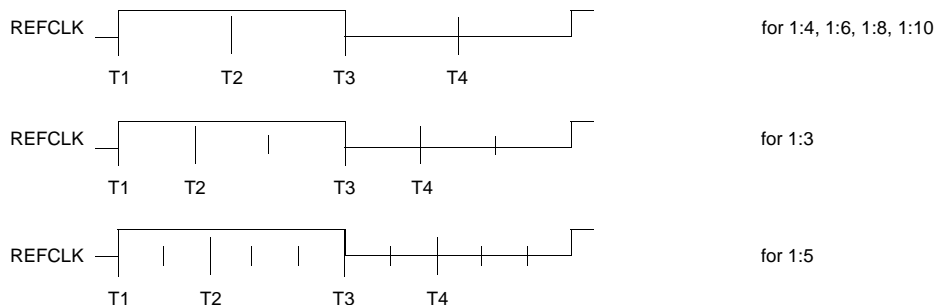

Figure 10. Internal Tick Spacing for Memory Controller Signals

The UPM machine and GPCM machine outputs change on the internal tick selected by the memory controller configuration. The AC timing specifications are relative to the internal tick. SDRAM machine outputs change only on the REFCLK rising edge.

**Table 14. AC Timing for SIU Inputs**

No.	Characteristic	Ref = CLKIN at 1.1 V and 100/133 MHz	Units
10	Hold time for all signals after the 50% level of the REFCLK rising edge	0.5	ns
11a	$\overline{\text{ARTRY}}/\overline{\text{ABB}}$ set-up time before the 50% level of the REFCLK rising edge	3.1	ns
11b	$\overline{\text{DBG}}/\overline{\text{DBB}}/\overline{\text{BG}}/\overline{\text{BR}}/\overline{\text{TC}}$ set-up time before the 50% level of the REFCLK rising edge	3.6	ns
11c	$\overline{\text{AACK}}$ set-up time before the 50% level of the REFCLK rising edge	3.0	ns
11d	$\overline{\text{TA}}/\overline{\text{TEA}}/\overline{\text{PSDVAL}}$ set-up time before the 50% level of the REFCLK rising edge <ul style="list-style-type: none"> <li>Data-pipeline mode</li> <li>Non-pipeline mode</li> </ul>	3.5 4.4	ns ns
12	Data bus set-up time before REFCLK rising edge in Normal mode <ul style="list-style-type: none"> <li>Data-pipeline mode</li> <li>Non-pipeline mode</li> </ul>	1.9 4.2	ns ns
13 <sup>1</sup>	Data bus set-up time before the 50% level of the REFCLK rising edge in ECC and PARITY modes <ul style="list-style-type: none"> <li>Data-pipeline mode</li> <li>Non-pipeline mode</li> </ul>	2.0 8.2	ns ns
14 <sup>1</sup>	DP set-up time before the 50% level of the REFCLK rising edge <ul style="list-style-type: none"> <li>Data-pipeline mode</li> <li>Non-pipeline mode</li> </ul>	2.0 7.9	ns ns
15a	$\overline{\text{TS}}$ and Address bus set-up time before the 50% level of the REFCLK rising edge <ul style="list-style-type: none"> <li>Extra cycle mode (SIUBCR[EXDD] = 0)</li> <li>No extra cycle mode (SIUBCR[EXDD] = 1)</li> </ul>	4.2 5.5	ns ns
15b	Address attributes: $\overline{\text{TT}}/\overline{\text{TBST}}/\overline{\text{TSZ}}/\overline{\text{GBL}}$ set-up time before the 50% level of the REFCLK rising edge <ul style="list-style-type: none"> <li>Extra cycle mode (SIUBCR[EXDD] = 0)</li> <li>No extra cycle mode (SIUBCR[EXDD] = 1)</li> </ul>	3.7 4.8	ns ns
16	PUPMWAIT signal set-up time before the 50% level of the REFCLK rising edge	3.7	ns
17	$\overline{\text{IRQx}}$ setup time before the 50% level; of the REFCLK rising edge <sup>3</sup>	4.0	ns
18	$\overline{\text{IRQx}}$ minimum pulse width <sup>3</sup>	$6.0 + T_{\text{REFCLK}}$	ns
<b>Notes:</b>	<ol style="list-style-type: none"> <li>1. Timings specifications 13 and 14 in non-pipeline mode are more restrictive than MSC8102 timings.</li> <li>2. Values are measured from the 50% TTL transition level relative to the 50% level of the REFCLK rising edge.</li> <li>3. Guaranteed by design.</li> </ol>		

Table 15. AC Timing for SIU Outputs

No.	Characteristic	Bus Speed in MHz <sup>3</sup> Ref = CLKIN at 1.1 V and 100/ 133 MHz	Units
30 <sup>2</sup>	Minimum delay from the 50% level of the REFCLK for all signals	0.9	ns
31	$\overline{\text{PSDVAL}}/\overline{\text{TEA}}/\overline{\text{TA}}$ max delay from the 50% level of the REFCLK rising edge	6.0	ns
32a	Address bus max delay from the 50% level of the REFCLK rising edge <ul style="list-style-type: none"> <li>• Multi-master mode (SIUBCR[EBM] = 1)</li> <li>• Single-master mode (SIUBCR[EBM] = 0)</li> </ul>	6.4 5.3	ns ns
32b	Address attributes: $\overline{\text{TT}}[0-1]/\overline{\text{TBST}}/\overline{\text{TSZ}}/\overline{\text{GBL}}$ max delay from the 50% level of the REFCLK rising edge	6.4	ns
32c	Address attributes: $\overline{\text{TT}}[2-4]/\overline{\text{TC}}$ max delay from the 50% level of the REFCLK rising edge	6.9	ns
32d	$\overline{\text{BADDR}}$ max delay from the 50% level of the REFCLK rising edge	5.2	ns
33a	Data bus max delay from the 50% level of the REFCLK rising edge <ul style="list-style-type: none"> <li>• Data-pipeline mode</li> <li>• Non-pipeline mode</li> </ul>	4.8 7.1	ns ns
33b	DP max delay from the 50% level of the REFCLK rising edge <ul style="list-style-type: none"> <li>• Data-pipeline mode</li> <li>• Non-pipeline mode</li> </ul>	6.0 7.5	ns ns
34	Memory controller signals/ $\overline{\text{ALE}}/\overline{\text{CS}}[0-4]$ max delay from the 50% level of the REFCLK rising edge	5.1	ns
35a	$\overline{\text{DBG}}/\overline{\text{BG}}/\overline{\text{BR}}/\overline{\text{DBB}}$ max delay from the 50% level of the REFCLK rising edge	6.0	ns
35b	$\overline{\text{AACK}}/\overline{\text{ABB}}/\overline{\text{TS}}/\overline{\text{CS}}[5-7]$ max delay from the 50% level of the REFCLK rising edge	5.5	ns
<b>Notes:</b>	<ol style="list-style-type: none"> <li>1. Values are measured from the 50% level of the REFCLK rising edge to the 50% signal level and assume a 20 pF load except where otherwise specified.</li> <li>2. Except for specification 30, which is specified for a 10 pF load, all timings in this table are specified for a 20 pF load. Decreasing the load results in a timing decrease at the rate of 0.3 ns per 5 pF decrease in load. Increasing the load results in a timing increase at the rate of 0.15 ns per 5 pF increase in load.</li> <li>3. The maximum bus frequency depends on the mode:                             <ul style="list-style-type: none"> <li>• In 60x-compatible mode connected to another MSC8113 device, the frequency is determined by adding the input and output longest timing values, which results in the total delay for 20 pF output capacitance. You must also account for other influences that can affect timing, such as on-board clock skews, on-board noise delays, and so on.</li> <li>• In single-master mode, the frequency depends on the timing of the devices connected to the MSC8113.</li> <li>• To achieve maximum performance on the bus in single-master mode, disable the DBB signal by writing a 1 to the SIUMCR[BDD] bit. See the SIU chapter in the <i>MSC8113 Reference Manual</i> for details.</li> </ul> </li> </ol>		

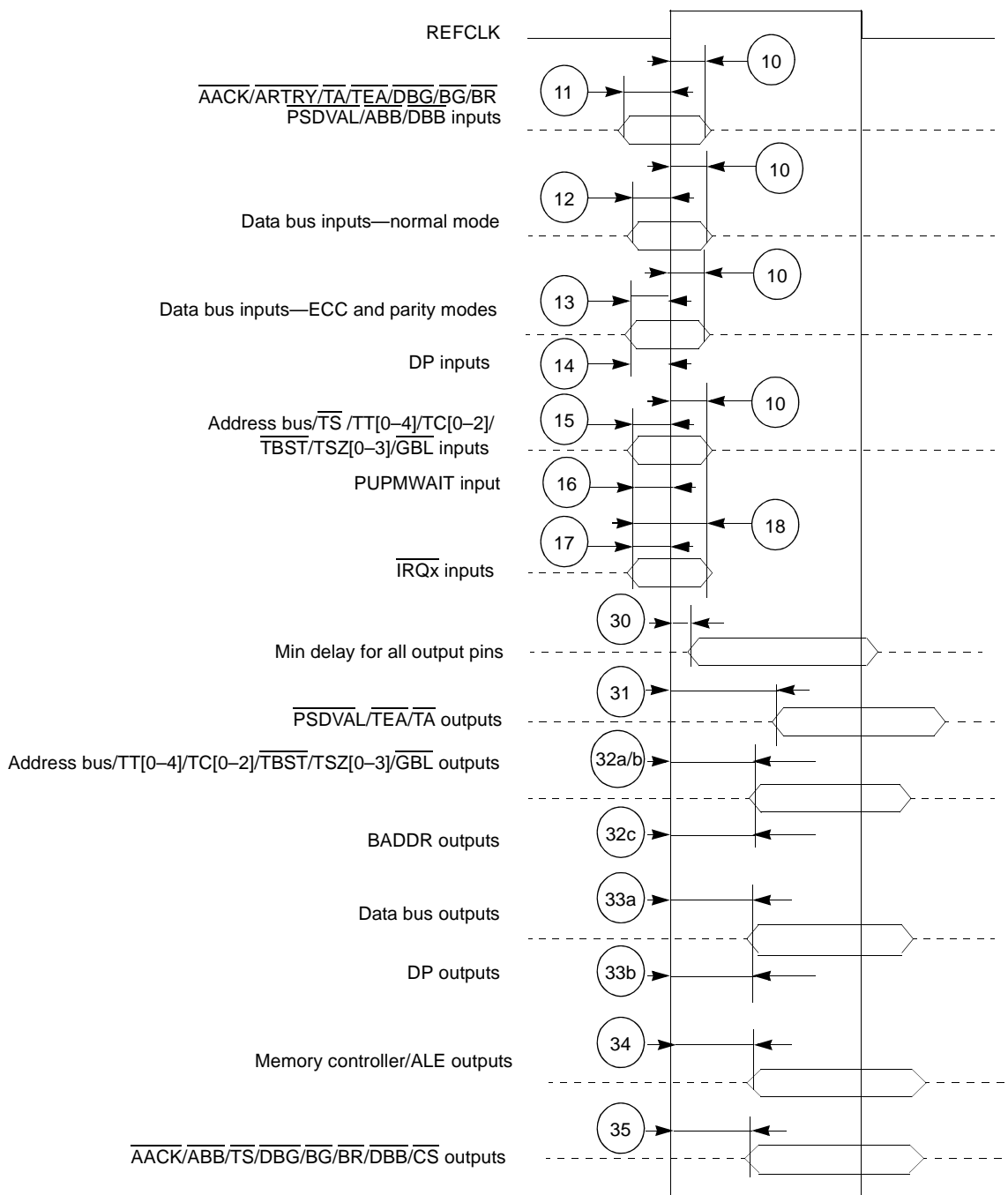

Figure 11. SIU Timing Diagram

### 2.5.5.2 CLKIN to CLKOUT Skew

Table 17 describes the CLKOUT-to-CLKIN skew timing.

Table 16. CLKOUT Skew

No.	Characteristic	Min <sup>1</sup>	Max <sup>1</sup>	Units
20	Rise-to-rise skew	0.0	0.95	ns
21	Fall-to-fall skew	-1.5	1.0	ns
23	CLKOUT phase (1.1 V, 133 MHz) • Phase high • Phase low	2.2	—	ns
		2.2	—	ns
24	CLKOUT phase (1.1 V, 100 MHz) • Phase high • Phase low	3.3	—	ns
		3.3	—	ns
<b>Notes:</b> <ol style="list-style-type: none"> <li>1. A positive number indicates that CLKOUT precedes CLKIN, A negative number indicates that CLKOUT follows CLKIN.</li> <li>2. Skews are measured in clock mode 29, with a CLKIN:CLKOUT ratio of 1:1. The same skew is valid for all clock modes.</li> <li>3. CLKOUT skews are measured using a load of 10 pF.</li> <li>4. CLKOUT skews and phase are not measured for 500/166 Mhz parts because these parts only use CLKIN mode.</li> </ol>				

For designs that use the CLKOUT synchronization mode, use the skew values listed in Table 16 to adjust the rise-to-fall timing values specified for CLKIN synchronization. Figure 12 shows the relationship between the CLKOUT and CLKIN timings.

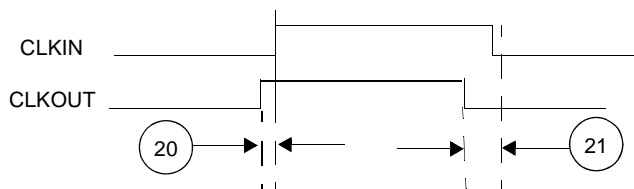

Figure 12. CLKOUT and CLKIN Signals.

### 2.5.5.3 DMA Data Transfers

Table 17 describes the DMA signal timing.

Table 17. DMA Signals

No.	Characteristic	Ref = CLKIN		Units
		Min	Max	
37	DREQ set-up time before the 50% level of the falling edge of REFCLK	5.0	—	ns
38	DREQ hold time after the 50% level of the falling edge of REFCLK	0.5	—	ns
39	DONE set-up time before the 50% level of the rising edge of REFCLK	5.0	—	ns
40	DONE hold time after the 50% level of the rising edge of REFCLK	0.5	—	ns
41	DACK/DRACK/DONE delay after the 50% level of the REFCLK rising edge	0.5	7.5	ns

The DREQ signal is synchronized with REFCLK. To achieve fast response, a synchronized peripheral should assert DREQ according to the timings in Table 17. Figure 13 shows synchronous peripheral interaction.

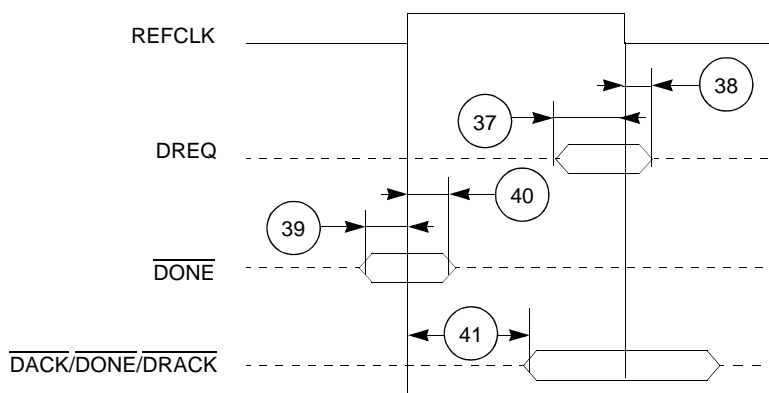

Figure 13. DMA Signals

## 2.5.6 DSI Timing

The timings in the following sections are based on a 20 pF capacitive load.

### 2.5.6.1 DSI Asynchronous Mode

Table 18. DSI Asynchronous Mode Timing

No.	Characteristics	Min	Max	Unit
100	Attributes <sup>1</sup> set-up time before strobe (HWBS[n]) assertion	1.5	—	ns
101	Attributes <sup>1</sup> hold time after data strobe deassertion	1.3	—	ns
102	Read/Write data strobe deassertion width: <ul style="list-style-type: none"> <li>• DCR[HTAAD] = 1 <ul style="list-style-type: none"> <li>— Consecutive access to the same DSI</li> <li>— Different device with DCR[HTADT] = 01</li> <li>— Different device with DCR[HTADT] = 10</li> <li>— Different device with DCR[HTADT] = 11</li> </ul> </li> <li>• DCR[HTAAD] = 0</li> </ul>	$1.8 + T_{REFCLK}$ $5 + T_{REFCLK}$ $5 + (1.5 \times T_{REFCLK})$ $5 + (2.5 \times T_{REFCLK})$ $1.8 + T_{REFCLK}$	—	ns
103	Read data strobe deassertion to output data high impedance	—	8.5	ns
104	Read data strobe assertion to output data active from high impedance	2.0	—	ns
105	Output data hold time after read data strobe deassertion	2.2	—	ns
106	Read/Write data strobe assertion to $\overline{HTA}$ active from high impedance	2.2	—	ns
107	Output data valid to $\overline{HTA}$ assertion	3.2	—	ns
108	Read/Write data strobe assertion to $\overline{HTA}$ valid <sup>2</sup>	—	7.4	ns
109	Read/Write data strobe deassertion to output $\overline{HTA}$ high impedance. (DCR[HTAAD] = 0, $\overline{HTA}$ at end of access released at logic 0)	—	6.5	ns
110	Read/Write data strobe deassertion to output $\overline{HTA}$ deassertion. (DCR[HTAAD] = 1, $\overline{HTA}$ at end of access released at logic 1)	—	6.5	ns
111	Read/Write data strobe deassertion to output $\overline{HTA}$ high impedance. (DCR[HTAAD] = 1, $\overline{HTA}$ at end of access released at logic 1 <ul style="list-style-type: none"> <li>• DCR[HTADT] = 01</li> <li>• DCR[HTADT] = 10</li> <li>• DCR[HTADT] = 11</li> </ul>	—	$5 + T_{REFCLK}$ $5 + (1.5 \times T_{REFCLK})$ $5 + (2.5 \times T_{REFCLK})$	ns
112	Read/Write data strobe assertion width	$1.8 + T_{REFCLK}$	—	ns
201	Host data input set-up time before write data strobe deassertion	1.0	—	ns
202	Host data input hold time after write data strobe deassertion	1.7	—	ns
<b>Notes:</b>	<ol style="list-style-type: none"> <li>Attributes refers to the following signals: <math>\overline{HCS}</math>, HA[11–29], HCID[0–4], HDST, HRW, <math>\overline{HRDS}</math>, and HWBSn.</li> <li>This specification is tested in dual-strobe mode. Timing in single-strobe mode is guaranteed by design.</li> <li>All values listed in this table are tested or guaranteed by design.</li> </ol>			

Figure 14 shows DSI asynchronous read signals timing.

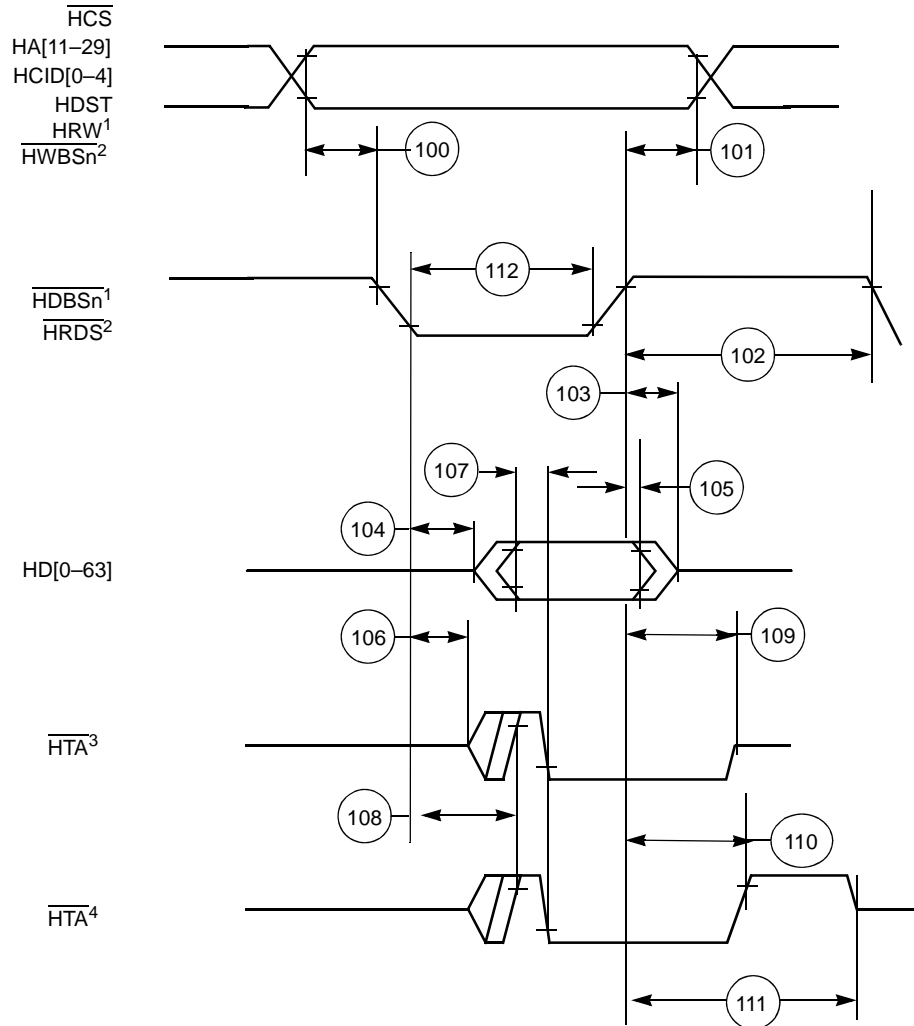

- Notes:**
1. Used for single-strobe mode access.
  2. Used for dual-strobe mode access.
  3. HTA released at logic 0 (DCR[HTAAD] = 0) at end of access; used with pull-down implementation.
  4. HTA released at logic 1 (DCR[HTAAD] = 1) at end of access; used with pull-up implementation.

Figure 14. Asynchronous Single- and Dual-Strobe Modes Read Timing Diagram

Figure 15 shows DSI asynchronous write signals timing.

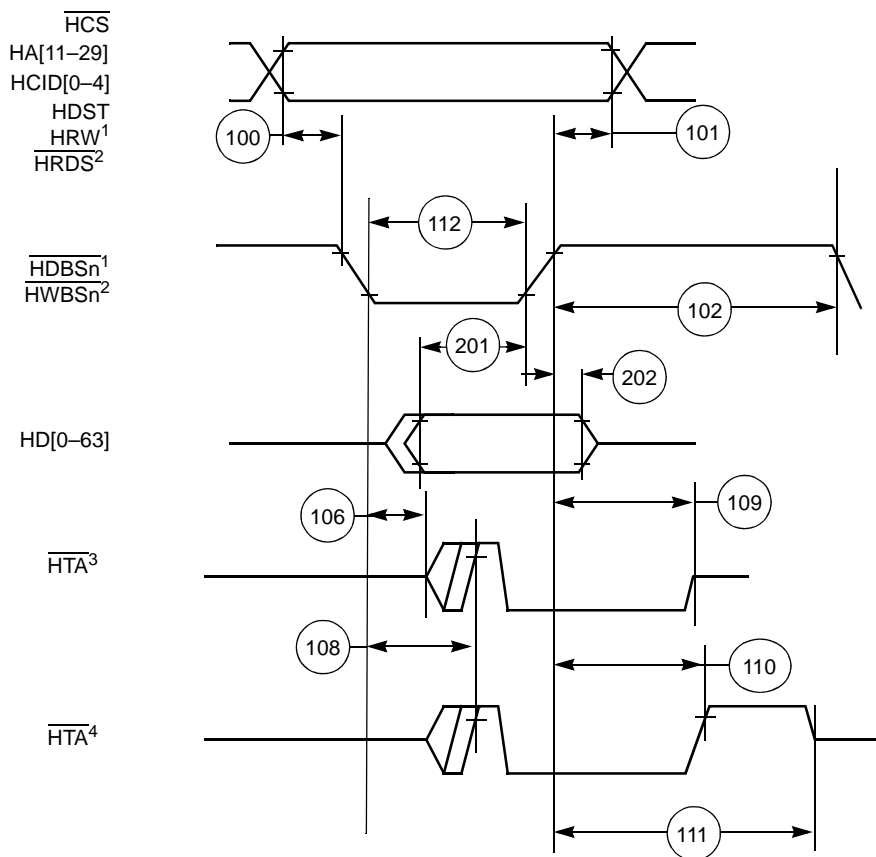

- Notes:**
1. Used for single-strobe mode access.
  2. Used for dual-strobe mode access.
  3. HTA released at logic 0 (DCR[HTAAD] = 0) at end of access; used with pull-down implementation.
  4. HTA released at logic 1 (DCR[HTAAD] = 1) at end of access; used with pull-up implementation.

**Figure 15. Asynchronous Single- and Dual-Strobe Modes Write Timing Diagram**

Figure 16 shows DSI asynchronous broadcast write signals timing.

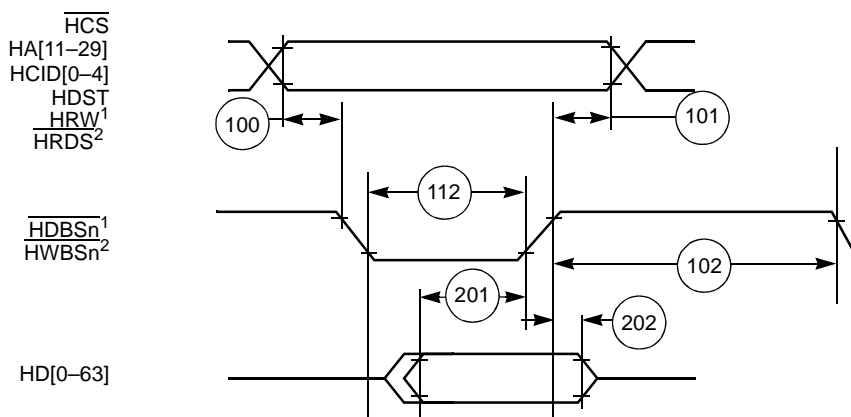

- Notes:**
1. Used for single-strobe mode access.
  2. Used for dual-strobe mode access.

**Figure 16. Asynchronous Broadcast Write Timing Diagram**

## 2.5.6.2 DSI Synchronous Mode

**Table 19. DSI Inputs in Synchronous Mode**

No.	Characteristic	Expression	1.1 V Core		Units
			Min	Max	
120	HCLKIN cycle time <sup>1,2</sup>	HTC	10.0	55.6	ns
121	HCLKIN high pulse width	$(0.5 \pm 0.1) \times \text{HTC}$	4.0	33.3	ns
122	HCLKIN low pulse width	$(0.5 \pm 0.1) \times \text{HTC}$	4.0	33.3	ns
123	HA[11–29] inputs set-up time	—	1.2	—	ns
124	HD[0–63] inputs set-up time	—	0.6	—	ns
125	HCID[0–4] inputs set-up time	—	1.3	—	ns
126	All other inputs set-up time	—	1.2	—	ns
127	All inputs hold time	—	1.5	—	ns

**Notes:**

1. Values are based on a frequency range of 18–100 MHz.
2. Refer to **Table 7** for HCLKIN frequency limits.

**Table 20. DSI Outputs in Synchronous Mode**

No.	Characteristic	1.1 V Core		Units
		Min	Max	
128	HCLKIN high to HD[0–63] output active	2.0	—	ns
129	HCLKIN high to HD[0–63] output valid	—	7.6	ns
130	HD[0–63] output hold time	1.7	—	ns
131	HCLKIN high to HD[0–63] output high impedance	—	8.3	ns
132	HCLKIN high to HTA output active	2.2	—	ns
133	HCLKIN high to HTA output valid	—	7.4	ns
134	HTA output hold time	1.7	—	ns
135	HCLKIN high to HTA high impedance	—	7.5	ns

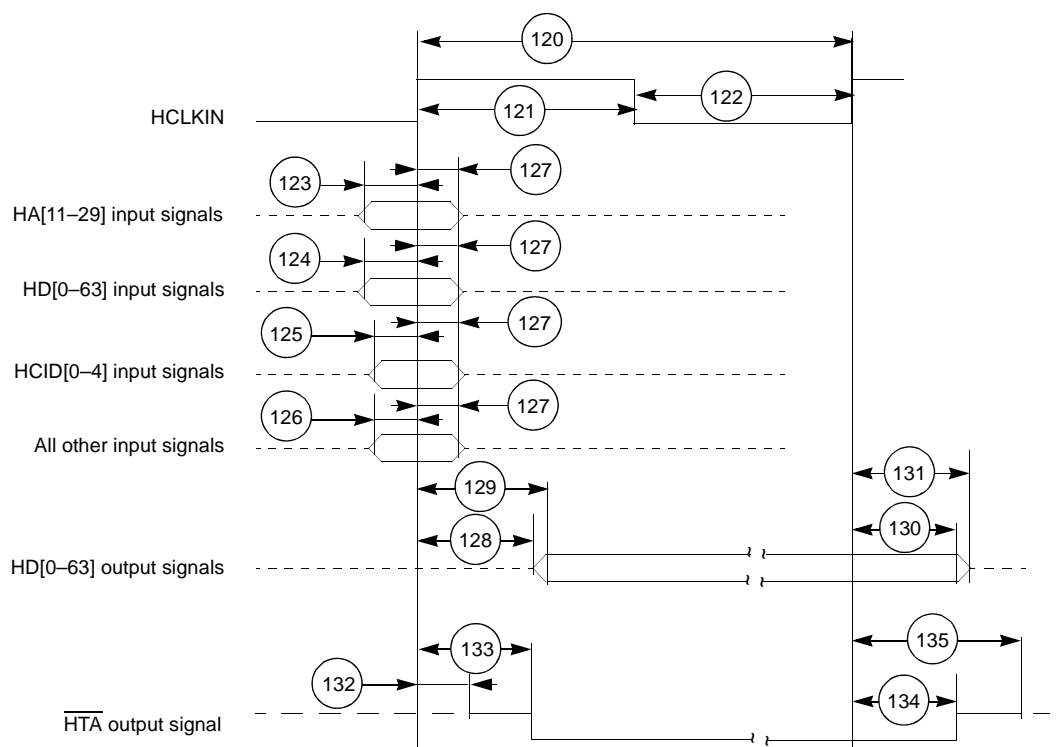

Figure 17. DSI Synchronous Mode Signals Timing Diagram

## 2.5.7 TDM Timing

Table 21. TDM Timing

No.	Characteristic	Expression	1.1 V Core		Units
			Min	Max	
300	TDMxRCLK/TDMxTCLK	$TC^1$	16	—	ns
301	TDMxRCLK/TDMxTCLK high pulse width	$(0.5 \pm 0.1) \times TC$	7	—	ns
302	TDMxRCLK/TDMxTCLK low pulse width	$(0.5 \pm 0.1) \times TC$	7	—	ns
303	TDM receive all input set-up time		1.3	—	ns
304	TDM receive all input hold time		1.0	—	ns
305	TDMxTCLK high to TDMxTDAT/TDMxRCLK output active <sup>2,3</sup>		2.8	—	ns
306	TDMxTCLK high to TDMxTDAT/TDMxRCLK output		—	10.0	ns
307	All output hold time <sup>4</sup>		2.5	—	ns
308	TDMxTCLK high to TDMxTDAT/TDMxRCLK output high impedance <sup>2,3</sup>		—	10.7	ns
309	TDMxTCLK high to TDMxTSYN output valid <sup>2</sup>		—	9.7	ns
310	TDMxTSYN output hold time <sup>4</sup>		2.5	—	ns

**Notes:**

1. Values are based on a a maximum frequency of 62.5 MHz. The TDM interface supports any frequency below 62.5 MHz. Devices operating at 300 MHz are limited to a maximum TDMxRCLK/TDMxTCLK frequency of 50 MHz.
2. Values are based on 20 pF capacitive load.
3. When configured as an output, TDMxRCLK acts as a second data link. See the *MSC8113 Reference Manual* for details.
4. Values are based on 10 pF capacitive load.

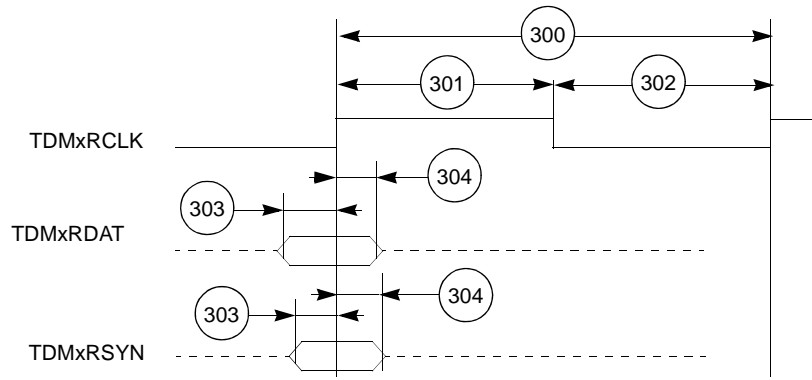

Figure 18. TDM Inputs Signals

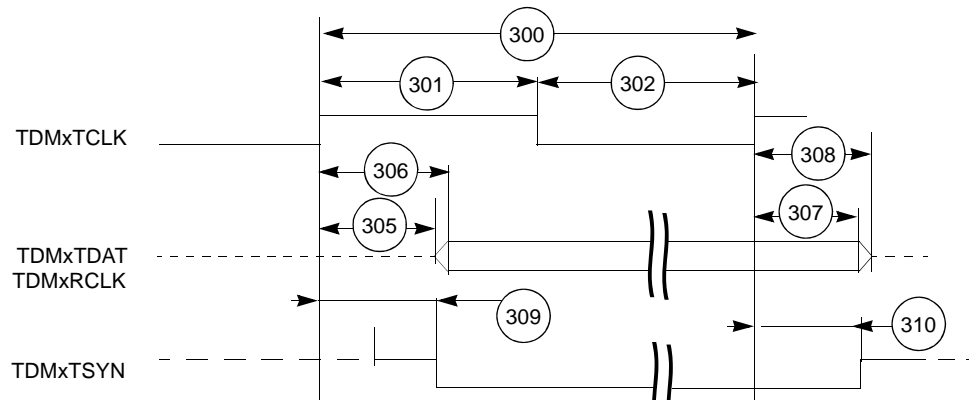

Figure 19. TDM Output Signals

## 2.5.8 UART Timing

Table 22. UART Timing

No.	Characteristics	Expression	Min	Max	Unit
400	URXD and UTXD inputs high/low duration	$16 \times T_{REFCLK}$	160.0	—	ns
401	URXD and UTXD inputs rise/fall time			10	ns
402	UTXD output rise/fall time			10	ns

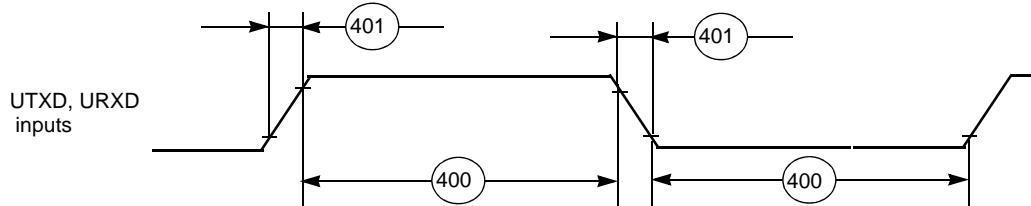

Figure 20. UART Input Timing

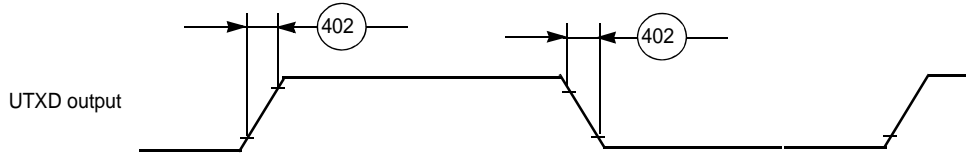

Figure 21. UART Output Timing

## 2.5.9 Timer Timing

Table 23. Timer Timing

No.	Characteristics	Ref = CLKIN		Unit
		Min	Max	
500	TIMERx frequency	10.0	—	ns
501	TIMERx Input high period	4.0	—	ns
502	TIMERx Output low period	4.0	—	ns
503	TIMERx Propagations delay from its clock input	3.1	9.5	ns

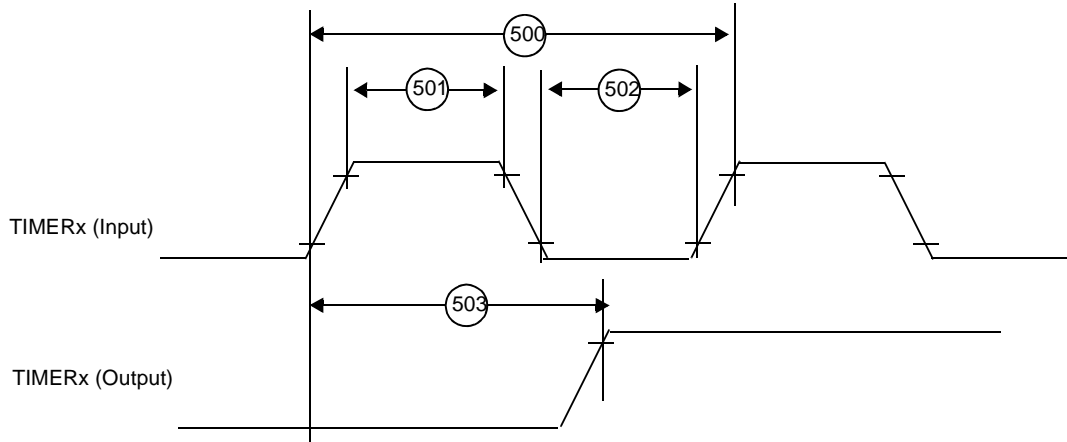

Figure 22. Timer Timing

## 2.5.10 Ethernet Timing

### 2.5.10.1 Management Interface Timing

Table 24. Ethernet Controller Management Interface Timing

No.	Characteristics	Min	Max	Unit
801	ETHMDIO to ETHMDC rising edge set-up time	10	—	ns
802	ETHMDC rising edge to ETHMDIO hold time	10	—	ns

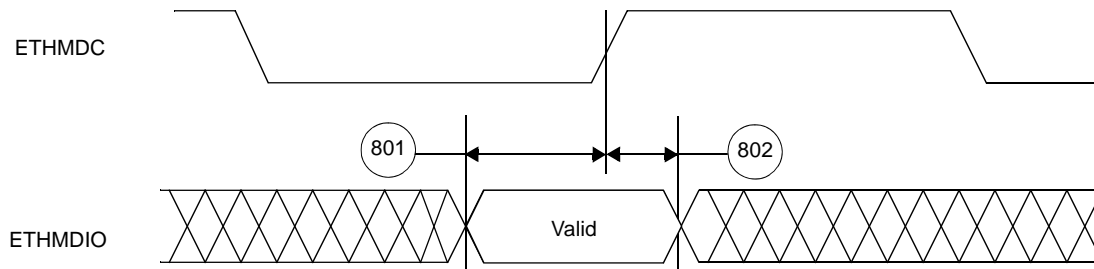
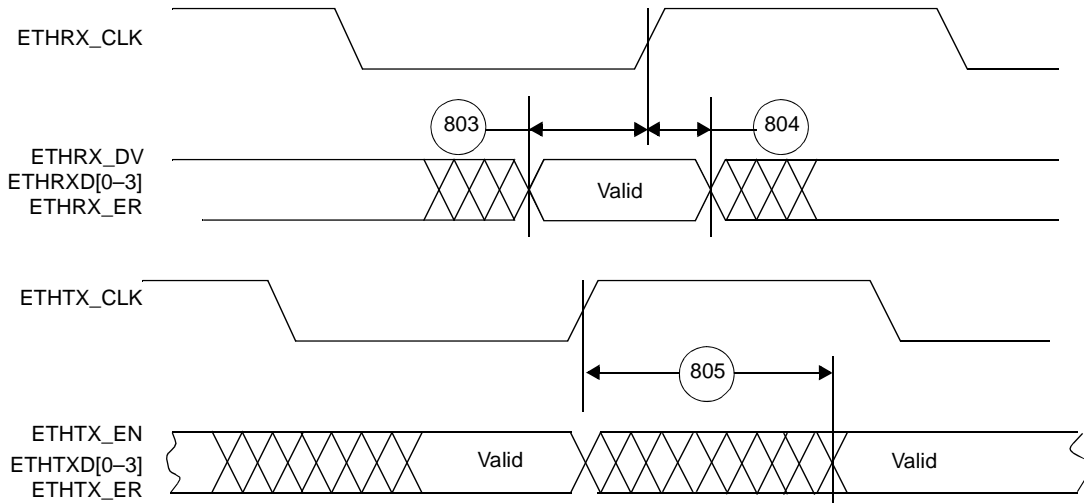

Figure 23. MDIO Timing Relationship to MDC

## 2.5.10.2 MII Mode Timing

**Table 25. MII Mode Signal Timing**

No.	Characteristics	1.1 V Core		Unit
		Min	Max	
803	ETHRX_DV, ETHRXD[0-3], ETHRX_ER to ETHRX_CLK rising edge set-up time	3.5	—	ns
804	ETHRX_CLK rising edge to ETHRX_DV, ETHRXD[0-3], ETHRX_ER hold time	3.5	—	ns
805	ETHTX_CLK to ETHTX_EN, ETHTXD[0-3], ETHTX_ER output delay	1	14.6	ns

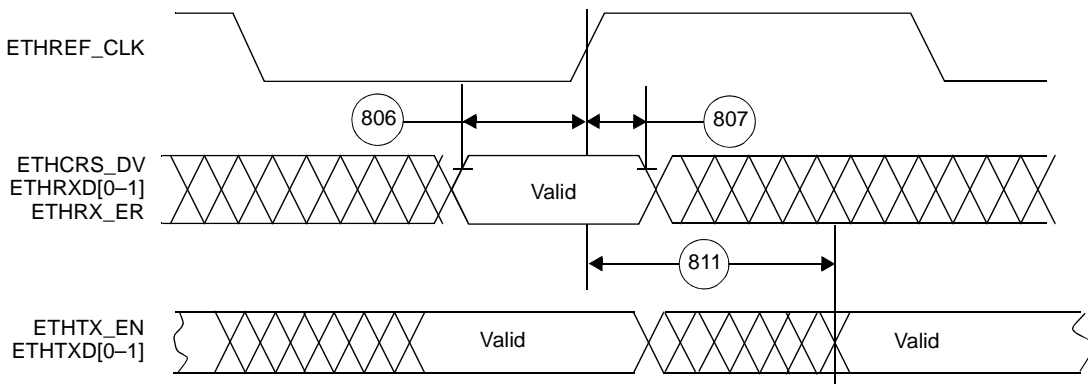

**Figure 24. MII Mode Signal Timing**

## 2.5.10.3 RMII Mode

**Table 26. RMII Mode Signal Timing**

No.	Characteristics	1.1 V Core		Unit
		Min	Max	
806	ETHTX_EN, ETHRXD[0-1], ETHCRS_DV, ETHRX_ER to ETHREF_CLK rising edge set-up time	1.6	—	ns
807	ETHREF_CLK rising edge to ETHRXD[0-1], ETHCRS_DV, ETHRX_ER hold time	1.6	—	ns
811	ETHREF_CLK rising edge to ETHTXD[0-1], ETHTX_EN output delay.	3	12.5	ns



**Figure 25. RMII Mode Signal Timing**

## 2.5.10.4 SMII Mode

**Table 27. SMII Mode Signal Timing**

No.	Characteristics	Min	Max	Unit
808	ETHSYNC_IN, ETHRXD to ETHCLOCK rising edge set-up time	1.0	—	ns
809	ETHCLOCK rising edge to ETHSYNC_IN, ETHRXD hold time	1.0	—	ns
810	ETHCLOCK rising edge to ETHSYNC, ETHTXD output delay	1.5 <sup>1</sup>	6.0 <sup>2</sup>	ns

**Notes:**

1. Measured using a 5 pF load.
2. Measured using a 15 pF load.

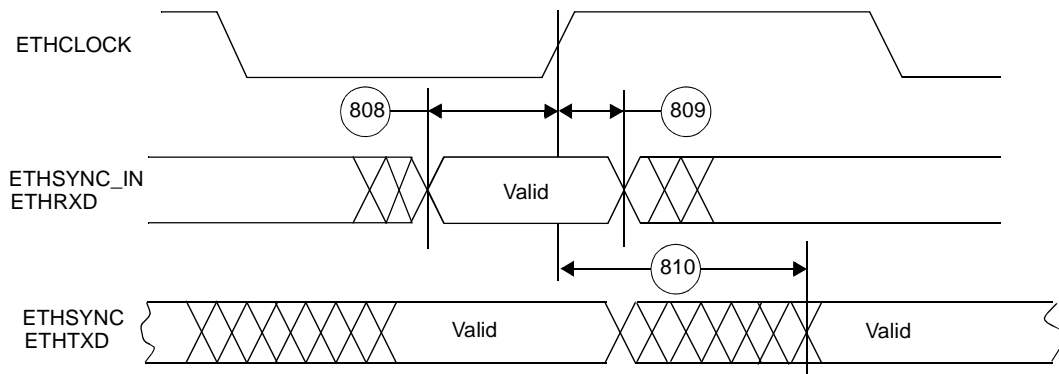
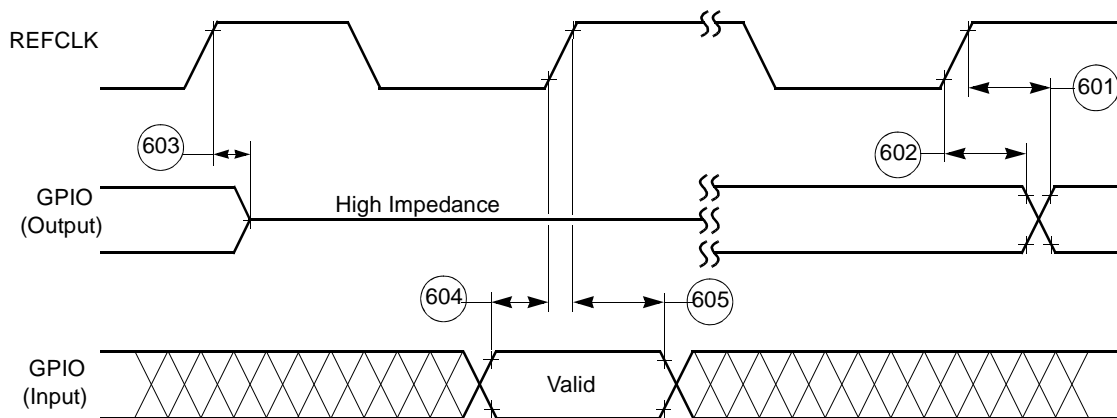

**Figure 26. SMII Mode Signal Timing**

## 2.5.11 GPIO Timing

**Table 28. GPIO Timing**

No.	Characteristics	Ref = CLKIN		Unit
		Min	Max	
601	REFCLK edge to GPIO out valid (GPIO out delay time)	—	6.1	ns
602	REFCLK edge to GPIO out not valid (GPIO out hold time)	1.1	—	ns
603	REFCLK edge to high impedance on GPIO out	—	5.4	ns
604	GPIO in valid to REFCLK edge (GPIO in set-up time)	3.5	—	ns
605	REFCLK edge to GPIO in not valid (GPIO in hold time)	0.5	—	ns



**Figure 27. GPIO Timing**

## 2.5.12 EE Signals

**Table 29. EE Pin Timing**

Number	Characteristics	Type	Min
65	EE0 (input)	Asynchronous	4 core clock periods
66	EE1 (output)	Synchronous to Core clock	1 core clock period

**Notes:**

1. The core clock is the SC140 core clock. The ratio between the core clock and CLKOUT is configured during power-on-reset.
2. Refer to **Table 1-4** on page 1-6 for details on EE pin functionality.

**Figure 28** shows the signal behavior of the EE pins.

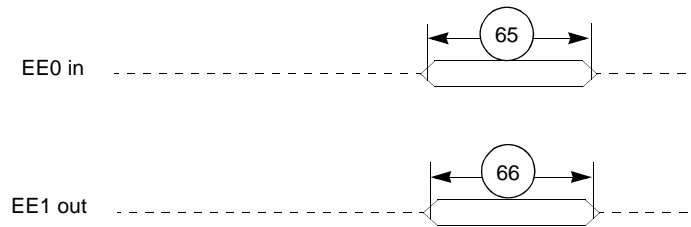

**Figure 28. EE Pin Timing**

## 2.5.13 JTAG Signals

**Table 30. JTAG Timing**

No.	Characteristics	All frequencies		Unit
		Min	Max	
700	TCK frequency of operation ( $1/(T_C \times 4)$ ; maximum 25 MHz)	0.0	25	MHz
701	TCK cycle time	40.0	—	ns
702	TCK clock pulse width measured at $V_M = 1.6$ V <ul style="list-style-type: none"> <li>• High</li> <li>• Low</li> </ul>	20.0 16.0	— —	ns ns
703	TCK rise and fall times	0.0	3.0	ns
704	Boundary scan input data set-up time	5.0	—	ns
705	Boundary scan input data hold time	20.0	—	ns
706	TCK low to output data valid	0.0	30.0	ns
707	TCK low to output high impedance	0.0	30.0	ns
708	TMS, TDI data set-up time	5.0	—	ns
709	TMS, TDI data hold time	20.0	—	ns
710	TCK low to TDO data valid	0.0	20.0	ns
711	TCK low to TDO high impedance	0.0	20.0	ns
712	TRST assert time	100.0	—	ns
713	TRST set-up time to TCK low	30.0	—	ns

**Note:** All timings apply to OnCE module data transfers as well as any other transfers via the JTAG port.

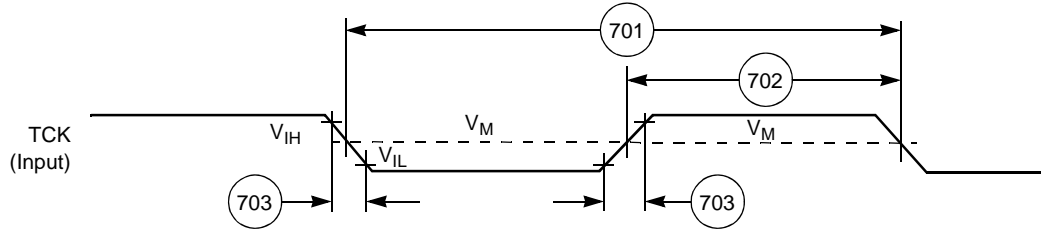

**Figure 29. Test Clock Input Timing Diagram**

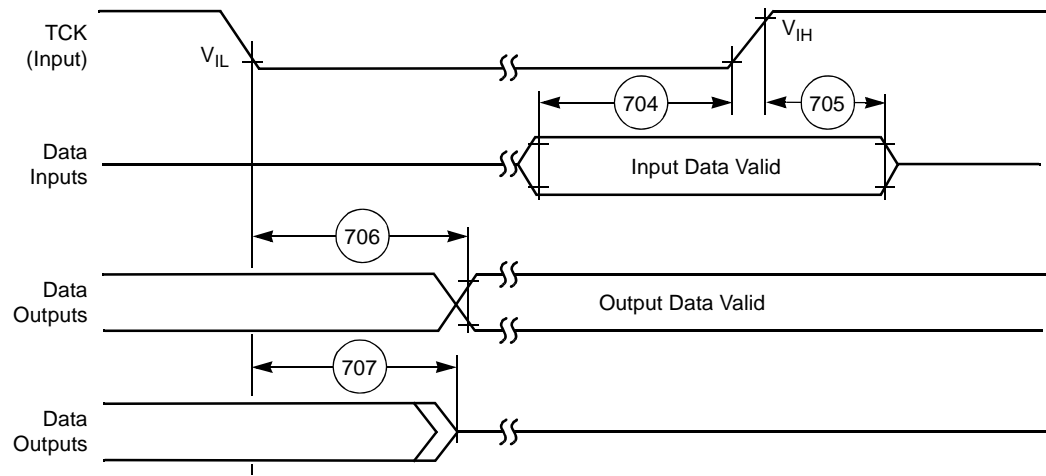

**Figure 30. Boundary Scan (JTAG) Timing Diagram**

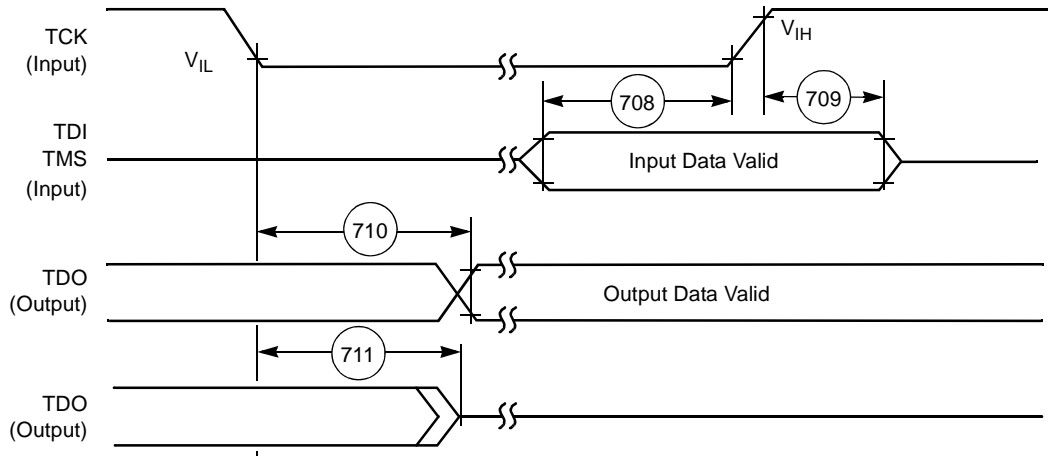

**Figure 31. Test Access Port Timing Diagram**

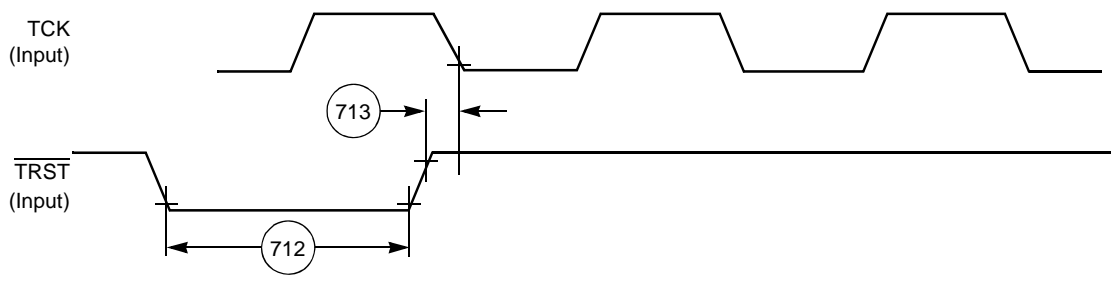

**Figure 32.  $\overline{TRST}$  Timing Diagram**

### 3 Hardware Design Considerations

The following sections discuss areas to consider when the MSC8113 device is designed into a system.

#### 3.1 Start-up Sequencing Recommendations

Use the following guidelines for start-up and power-down sequences:

- Assert  $\overline{\text{PORESET}}$  and  $\overline{\text{TRST}}$  before applying power and keep the signals driven low until the power reaches the required minimum power levels. This can be implemented via weak pull-down resistors.
- CLKIN can be held low or allowed to toggle during the beginning of the power-up sequence. However, CLKIN must start toggling before the deassertion of PORESET and after both power supplies have reached nominal voltage levels.
- If possible, bring up  $V_{\text{DD}}/V_{\text{CCSYN}}$  and  $V_{\text{DDH}}$  together. If it is not possible, raise  $V_{\text{DD}}/V_{\text{CCSYN}}$  first and then bring up  $V_{\text{DDH}}$ .  $V_{\text{DDH}}$  should not exceed  $V_{\text{DD}}/V_{\text{CCSYN}}$  until  $V_{\text{DD}}/V_{\text{CCSYN}}$  reaches its nominal voltage level. Similarly, bring both voltage levels down together. If that is not possible reverse the power-up sequence, with  $V_{\text{DDH}}$  going down first and then  $V_{\text{DD}}/V_{\text{CCSYN}}$ .

**Note:** This recommended power sequencing for the MSC8113 is different from the MSC8102.

External voltage applied to any input line must not exceed the I/O supply  $V_{\text{DDH}}$  by more than 0.8 V at any time, including during power-up. Some designs require pull-up voltages applied to selected input lines during power-up for configuration purposes. This is an acceptable exception to the rule. However, each such input can draw up to 80 mA per input pin per device in the system during start-up.

After power-up,  $V_{\text{DDH}}$  must not exceed  $V_{\text{DD}}/V_{\text{CCSYN}}$  by more than 2.6 V.

#### 3.2 Power Supply Design Considerations

When implementing a new design, use the guidelines described in the *MSC8113 Design Checklist* (AN3374 for optimal system performance. *MSC8122 and MSC8126 Power Circuit Design Recommendations and Examples* (AN2937) provides detailed design information.

**Figure 33** shows the recommended power decoupling circuit for the core power supply. The voltage regulator and the decoupling capacitors should supply the required device current without any drop in voltage on the device pins. The voltage on the package pins should not drop below the minimum specified voltage level even for a very short spikes. This can be achieved by using the following guidelines:

- For the core supply, use a voltage regulator rated at 1.1 V with nominal rating of at least 3 A. This rating does not reflect actual average current draw, but is recommended because it resists changes imposed by transient spikes and has better voltage recovery time than supplies with lower current ratings.
- Decouple the supply using low-ESR capacitors mounted as close as possible to the socket. **Figure 33** shows three capacitors in parallel to reduce the resistance. Three capacitors is a recommended minimum number. If possible, mount at least one of the capacitors directly below the MSC8113 device.

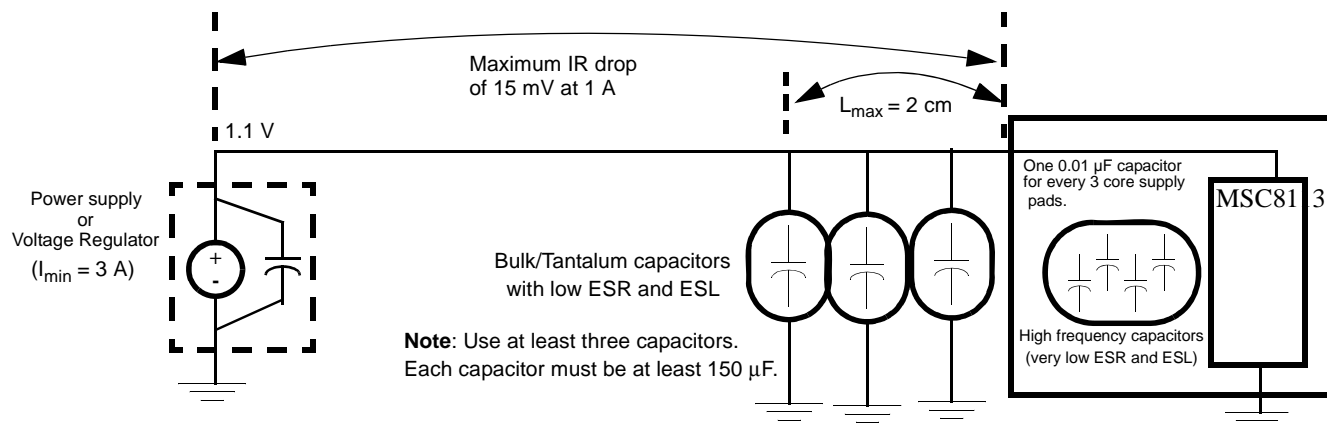
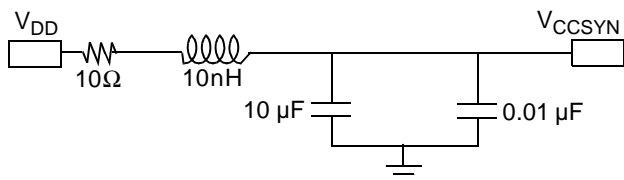

**Figure 33. Core Power Supply Decoupling**

Each  $V_{CC}$  and  $V_{DD}$  pin on the MSC8113 device should have a low-impedance path to the board power supply. Similarly, each GND pin should have a low-impedance path to the ground plane. The power supply pins drive distinct groups of logic on the chip. The  $V_{CC}$  power supply should have at least four 0.1  $\mu\text{F}$  by-pass capacitors to ground located as closely as possible to the four sides of the package. The capacitor leads and associated printed circuit traces connecting to chip  $V_{CC}$ ,  $V_{DD}$ , and GND should be kept to less than half an inch per capacitor lead. A four-layer board is recommended, employing two inner layers as  $V_{CC}$  and GND planes.

All output pins on the MSC8113 have fast rise and fall times. PCB trace interconnection length should be minimized to minimize undershoot and reflections caused by these fast output switching times. This recommendation particularly applies to the address and data buses. Maximum PCB trace lengths of six inches are recommended. For the DSI control signals in synchronous mode, ensure that the layout supports the DSI AC timing requirements and minimizes any signal crosstalk. Capacitance calculations should consider all device loads as well as parasitic capacitances due to the PCB traces. Attention to proper PCB layout and bypassing becomes especially critical in systems with higher capacitive loads because these loads create higher transient currents in the  $V_{CC}$ ,  $V_{DD}$ , and GND circuits. Pull up all unused inputs or signals that will be inputs during reset.

Special care should be taken to minimize the noise levels on the PLL supply pins. There is one pair of PLL supply pins:  $V_{CCSYN}$ - $GND_{SYN}$ . To ensure internal clock stability, filter the power to the  $V_{CCSYN}$  input with a circuit similar to the one in **Figure 34**. For optimal noise filtering, place the circuit as close as possible to  $V_{CCSYN}$ . The 0.01- $\mu\text{F}$  capacitor should be closest to  $V_{CCSYN}$ , followed by the 10- $\mu\text{F}$  capacitor, the 10-nH inductor, and finally the 10- $\Omega$  resistor to  $V_{DD}$ . These traces should be kept short and direct. Provide an extremely low impedance path to the ground plane for  $GND_{SYN}$ . Bypass  $GND_{SYN}$  to  $V_{CCSYN}$  by a 0.01- $\mu\text{F}$  capacitor located as close as possible to the chip package. For best results, place this capacitor on the backside of the PCB aligned with the depopulated void on the MSC8113 located in the square defined by positions, L11, L12, L13, M11, M12, M13, N11, N12, and N13.



**Figure 34.  $V_{CCSYN}$  Bypass**

### 3.3 Connectivity Guidelines

Unused output pins can be disconnected, and unused input pins should be connected to the non-active value, via resistors to  $V_{DDH}$  or GND, except for the following:

- If the DSI is unused (DDR[DSIDIS] is set),  $\overline{HCS}$  and  $\overline{HBCS}$  must be pulled up and all the rest of the DSI signals can be disconnected.
- When the DSI uses synchronous mode,  $\overline{HTA}$  must be pulled up. In asynchronous mode,  $\overline{HTA}$  should be pulled either up or down, depending on design requirements.
- $\overline{HDST}$  can be disconnected if the DSI is in big-endian mode, or if the DSI is in little-endian mode and the DCR[DSRFA] bit is set.
- When the DSI is in 64-bit data bus mode and DCR[BEM] is cleared, pull up  $\overline{HWBS[1-3]}/\overline{HDBS[1-3]}/\overline{HWBE[1-3]}/\overline{HDBE[1-3]}$  and  $\overline{HWBS[4-7]}/\overline{HDBS[4-7]}/\overline{HWBE[4-7]}/\overline{HDBE[4-7]}/\overline{PWE[4-7]}/\overline{PSDDQM[4-7]}/\overline{PBS[4-7]}$ .
- When the DSI is in 32-bit data bus mode and DCR[BEM] is cleared,  $\overline{HWBS[1-3]}/\overline{HDBS[1-3]}/\overline{HWBE[1-3]}/\overline{HDBE[1-3]}$  must be pulled up.
- When the DSI is in asynchronous mode,  $\overline{HBRST}$  and HCLKIN should either be disconnected or pulled up.
- The following signals must be pulled up:  $\overline{HRESET}$ ,  $\overline{SRESET}$ ,  $\overline{ARTRY}$ ,  $\overline{TA}$ ,  $\overline{TEA}$ ,  $\overline{PSDVAL}$ , and  $\overline{AACK}$ .
- In single-master mode (BCR[EBM] = 0) with internal arbitration (PPC\_ACR[EARB] = 0):
  - $\overline{BG}$ ,  $\overline{DBG}$ , and  $\overline{TS}$  can be left unconnected.
  - $\overline{EXT\_BG[2-3]}$ ,  $\overline{EXT\_DBG[2-3]}$ , and  $\overline{GBL}$  can be left unconnected if they are multiplexed to the system bus functionality. For any other functionality, connect the signal lines based on the multiplexed functionality.
  - $\overline{BR}$  must be pulled up.
  - $\overline{EXT\_BR[2-3]}$  must be pulled up if multiplexed to the system bus functionality.

- If there is an external bus master ( $BCR[EBM] = 1$ ):
  - $\overline{BR}$ ,  $\overline{BG}$ ,  $\overline{DBG}$ , and  $\overline{TS}$  must be pulled up.
  - $\overline{EXT\_BR[2-3]}$ ,  $\overline{EXT\_BG[2-3]}$ , and  $\overline{EXT\_DBG[2-3]}$  must be pulled up if multiplexed to the system bus functionality.
- In single-master mode,  $\overline{ABB}$  and  $\overline{DBB}$  can be selected as  $\overline{IRQ}$  inputs and be connected to the non-active value. In other modes, they must be pulled up.

**Note:** The MSC8113 does not support DLL-enabled mode. For the following two clock schemes, ensure that the DLL is disabled (that is, the DLLDIS bit in the Hard Reset Configuration Word is set).

- If no system synchronization is required (for example, the design does not use SDRAM), you can use any of the available clock modes.
- In the CLKIN synchronization mode, use the following connections:
  - Connect the oscillator output through a buffer to CLKIN.
  - Connect the CLKIN buffer output to the slave device (for example, SDRAM) making sure that the delay path between the clock buffer to the MSC8113 and the SDRAM is equal (that is, has a skew less than 100 ps).
  - Valid clock modes in this scheme are: 0, 7, 15, 19, 21, 23, 28, 29, 30, and 31.

**Note:** See the Clock chapter in the *MSC8113 Reference Manual* for details.

- If the 60x-compatible system bus is not used and SIUMCR[PBSE] is set,  $\overline{PPBS}$  can be disconnected. Otherwise, it should be pulled up.
- The following signals: SWTE, DSISYNC, DSI64, MODCK[1-2], CNFGS, CHIPID[0-3], RSTCONF and BM[0-2] are used to configure the MSC8113 and are sampled on the deassertion of the  $\overline{PORESET}$  signal. Therefore, they should be tied to GND or  $V_{DDH}$  or through a pull-down or a pull-up resistor until the deassertion of the  $\overline{PORESET}$  signal.
- When they are used,  $\overline{INT\_OUT}$  (if SIUMCR[INTODC] is cleared),  $\overline{NMI\_OUT}$ , and  $\overline{IRQxx}$  (if not full drive) signals must be pulled up.
- When the Ethernet controller is enabled and the SMII mode is selected, GPIO10 and GPIO14 must not be connected externally to any signal line.

**Note:** For details on configuration, see the *MSC8113 User's Guide* and *MSC8113 Reference Manual*. For additional information, refer to the *MSC8113 Design Checklist* (ANxxxx).

## 3.4 External SDRAM Selection

The external bus speed implemented in a system determines the speed of the SDRAM used on that bus. However, because of differences in timing characteristics among various SDRAM manufacturers, you may have use a faster speed rated SDRAM to assure efficient data transfer across the bus. For example, for 133 MHz operation, you may have to use 133 or 166 MHz SDRAM. Always perform a detailed timing analysis using the MSC8113 bus timing values and the manufacturer specifications for the SDRAM to ensure correct operation within your system design. The output delay listed in SDRAM specifications is usually given for a load of 30 pF. Scale the number to your specific board load using the typical scaling number provided by the SDRAM manufacturer.

## 3.5 Thermal Considerations

An estimation of the chip-junction temperature,  $T_J$ , in °C can be obtained from the following:

$$T_J = T_A + (R_{\theta JA} \times P_D) \quad \text{Eqn. 1}$$

where

- $T_A$  = ambient temperature near the package (°C)
- $R_{\theta JA}$  = junction-to-ambient thermal resistance (°C/W)
- $P_D = P_{INT} + P_{I/O}$  = power dissipation in the package (W)
- $P_{INT} = I_{DD} \times V_{DD}$  = internal power dissipation (W)
- $P_{I/O}$  = power dissipated from device on output pins (W)

The power dissipation values for the MSC8113 are listed in **Table 4**. The ambient temperature for the device is the air temperature in the immediate vicinity that would cool the device. The junction-to-ambient thermal resistances are JEDEC standard values that provide a quick and easy estimation of thermal performance. There are two values in common usage: the value determined on a single layer board and the value obtained on a board with two planes. The value that more closely approximates a specific application depends on the power dissipated by other components on the printed circuit board (PCB). The value obtained using a single layer board is appropriate for tightly packed PCB configurations. The value obtained using a board with internal planes is more appropriate for boards with low power dissipation (less than 0.02 W/cm<sup>2</sup> with natural convection) and well separated components. Based on an estimation of junction temperature using this technique, determine whether a more detailed thermal analysis is required. Standard thermal management techniques can be used to maintain the device thermal junction temperature below its maximum. If  $T_J$  appears to be too high, either lower the ambient temperature or the power dissipation of the chip. You can verify the junction temperature by measuring the case temperature using a small diameter thermocouple (40 gauge is recommended) or an infrared temperature sensor on a spot on the device case that is painted black. The MSC8113 device case surface is too shiny (low emissivity) to yield an accurate infrared temperature measurement. Use the following equation to determine  $T_J$ :

$$T_J = T_T + (\theta_{JA} \times P_D) \quad \text{Eqn. 2}$$

where

- $T_T$  = thermocouple (or infrared) temperature on top of the package (°C)
- $\theta_{JA}$  = thermal characterization parameter (°C/W)
- $P_D$  = power dissipation in the package (W)

**Note:** See *MSC8102, MSC8122, and MSC8126 Thermal Management Design Guidelines (AN2601/D)*.

## 4 Ordering Information

Consult a Freescale Semiconductor sales office or authorized distributor to determine product availability and place an order.

Part	Package Type	Core Voltage	Operating Temperature	Core Frequency (MHz)	Order Number	
					Lead-Free	Lead-Bearing
MSC8113	Flip Chip Plastic Ball Grid Array (FC-PBGA)	1.1 V	-40° to 105°C	300	MSC8113TVT3600V	MSC8113TMP3600V
				400	MSC8113TVT4800V	MSC8113TMP4800V

# 5 Package Information

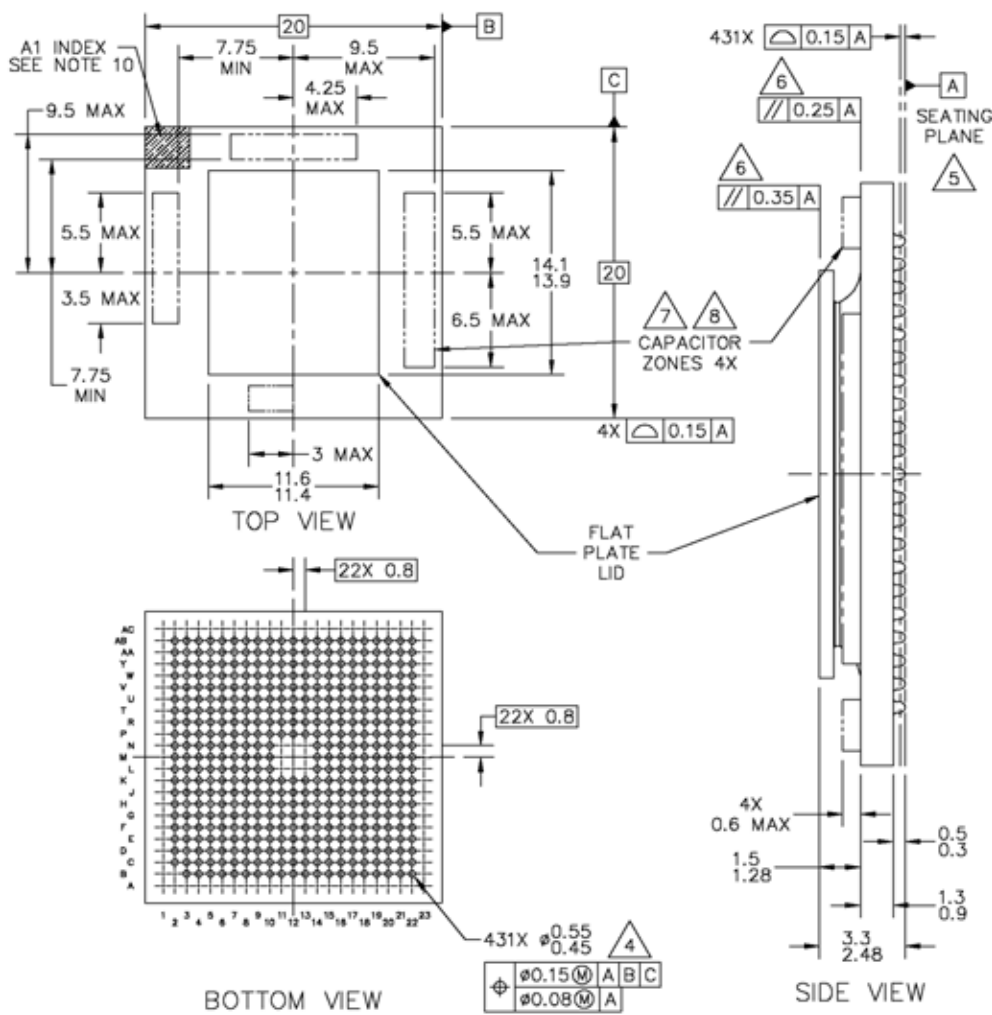

- Notes:**
1. All dimensions in millimeters.
  2. Dimensioning and tolerancing per ASME Y14.5M-1994.
  3. Features are symmetrical about the package center lines unless dimensioned otherwise.
- ⚠ Maximum solder ball diameter measured parallel to Datum A.
  - ⚠ Datum A, the seating plane, is determined by the spherical crowns of the solder balls.
  - ⚠ Parallelism measurement shall exclude any effect of mark on top surface of package.
  - ⚠ Capacitors may not be present on all devices.
  - ⚠ Caution must be taken not to short capacitors or exposed metal capacitor pads on package top.
  - ⚠ FC CBGA (Ceramic) package code: 5238.  
FC PBGA (Plastic) package code: 5263.
10. Pin 1 indicator can be in the form of number 1 marking or an "L" shape marking.

Figure 35. MSC8113 Mechanical Information, 431-pin FC-PBGA Package

# 6 Product Documentation

- *MSC8113 Technical Data Sheet* (MSC8113). Details the signals, AC/DC characteristics, clock signal characteristics, package and pinout, and electrical design considerations of the MSC8113 device.
- *MSC8113 Reference Manual* (MSC8113RM). Includes functional descriptions of the extended cores and all the internal subsystems including configuration and programming information.
- *Application Notes*. Cover various programming topics related to the StarCore DSP core and the MSC8113 device.
- *SC140 DSP Core Reference Manual*. Covers the SC140 core architecture, control registers, clock registers, program control, and instruction set.

## 7 Revision History

Table 31 provides a revision history for this data sheet.

**Table 31. Document Revision History**

Revision	Date	Description
0	May 2008	<ul style="list-style-type: none"><li>• Initial public release.</li></ul>
1	Dec. 2008	<ul style="list-style-type: none"><li>• Added <b>Figure 8</b> and associated text that was omitted from the previous revision on p. 17.</li><li>• Clarified the wording of note 2 in <b>Table 15</b> on p. 23.</li></ul>

## How to Reach Us:

### Home Page:

[www.freescale.com](http://www.freescale.com)

### Web Support:

<http://www.freescale.com/support>

### USA/Europe or Locations Not Listed:

Freescale Semiconductor, Inc.  
Technical Information Center, EL516  
2100 East Elliot Road  
Tempe, Arizona 85284  
+1-800-521-6274 or  
+1-480-768-2130  
[www.freescale.com/support](http://www.freescale.com/support)

### Europe, Middle East, and Africa:

Freescale Halbleiter Deutschland GmbH  
Technical Information Center  
Schatzbogen 7  
81829 Muenchen, Germany  
+44 1296 380 456 (English)  
+46 8 52200080 (English)  
+49 89 92103 559 (German)  
+33 1 69 35 48 48 (French)  
[www.freescale.com/support](http://www.freescale.com/support)

### Japan:

Freescale Semiconductor Japan Ltd.  
Headquarters  
ARCO Tower 15F  
1-8-1, Shimo-Meguro, Meguro-ku  
Tokyo 153-0064  
Japan  
0120 191014 or  
+81 3 5437 9125  
[support.japan@freescale.com](mailto:support.japan@freescale.com)

### Asia/Pacific:

Freescale Semiconductor China Ltd.  
Exchange Building 23F  
No. 118 Jianguo Road  
Chaoyang District  
Beijing 100022  
China  
+86 010 5879 8000  
[support.asia@freescale.com](mailto:support.asia@freescale.com)

### For Literature Requests Only:

Freescale Semiconductor  
Literature Distribution Center  
P.O. Box 5405  
Denver, Colorado 80217  
+1-800 441-2447 or  
+1-303-675-2140  
Fax: +1-303-675-2150  
LDCForFreescaleSemiconductor  
@hibbertgroup.com

Information in this document is provided solely to enable system and software implementers to use Freescale Semiconductor products. There are no express or implied copyright licenses granted hereunder to design or fabricate any integrated circuits or integrated circuits based on the information in this document.

Freescale Semiconductor reserves the right to make changes without further notice to any products herein. Freescale Semiconductor makes no warranty, representation or guarantee regarding the suitability of its products for any particular purpose, nor does Freescale Semiconductor assume any liability arising out of the application or use of any product or circuit, and specifically disclaims any and all liability, including without limitation consequential or incidental damages. "Typical" parameters that may be provided in Freescale Semiconductor data sheets and/or specifications can and do vary in different applications and actual performance may vary over time. All operating parameters, including "Typicals", must be validated for each customer application by customer's technical experts. Freescale Semiconductor does not convey any license under its patent rights nor the rights of others. Freescale Semiconductor products are not designed, intended, or authorized for use as components in systems intended for surgical implant into the body, or other applications intended to support or sustain life, or for any other application in which the failure of the Freescale Semiconductor product could create a situation where personal injury or death may occur. Should Buyer purchase or use Freescale Semiconductor products for any such unintended or unauthorized application, Buyer shall indemnify and hold Freescale Semiconductor and its officers, employees, subsidiaries, affiliates, and distributors harmless against all claims, costs, damages, and expenses, and reasonable attorney fees arising out of, directly or indirectly, any claim of personal injury or death associated with such unintended or unauthorized use, even if such claim alleges that Freescale Semiconductor was negligent regarding the design or manufacture of the part.

RoHS-compliant and/or Pb-free versions of Freescale products have the functionality and electrical characteristics as their non-RoHS-compliant and/or non-Pb-free counterparts. For further information, see <http://www.freescale.com> or contact your Freescale sales representative.

For information on Freescale's Environmental Products program, go to <http://www.freescale.com/epp>.

Freescale™, the Freescale logo, CodeWarrior, and StarCore are trademarks of Freescale Semiconductor, Inc. All other product or service names are the property of their respective owners.

© Freescale Semiconductor, Inc. 2008. All rights reserved.

## Looking for pricing, stock, or lifecycle information?

Click below to explore more details on WIN SOURCE:

- ⊖ [View MSC8113TMP3600V on WIN SOURCE](#)
- ⊖ [Freescale Semiconductor - NXP Information](#)

## Optimize Your Supply Chain with WIN SOURCE Solutions

- ✓ Global Sourcing Solution
- ✓ Obsolete Management
- ✓ Cost Control Management
- ✓ Shortage Management
- ✓ Alternative Solution
- ✓ Excess Inventory Management