



**THE DATASHEET OF  
MSD2714AT1**



# MSD2714AT1

Preferred Device

## VHF/UHF Transistor

### NPN Silicon

#### Features

- Pb-Free Package is Available

#### MAXIMUM RATINGS

| Rating                    | Symbol    | Max | Unit |
|---------------------------|-----------|-----|------|
| Collector-Emitter Voltage | $V_{CEO}$ | 25  | Vdc  |
| Collector-Base Voltage    | $V_{CBO}$ | 30  | Vdc  |
| Emitter-Base Voltage      | $V_{EBO}$ | 3.0 | Vdc  |

#### THERMAL CHARACTERISTICS

| Characteristic   | Symbol            | Max         | Unit                       |
|--|-------------------|-------------|----------------------------|
| Total Device Dissipation FR-5 Board<br>$T_A = 25^\circ\text{C}$<br>Derate above $25^\circ\text{C}$         | $P_D$<br>(Note 1) | 225<br>1.8  | mW<br>mW/ $^\circ\text{C}$ |
| Thermal Resistance, Junction-to-Ambient  | $R_{\theta JA}$   | 556         | $^\circ\text{C}/\text{W}$  |
| Total Device Dissipation Alumina<br>Substrate, $T_A = 25^\circ\text{C}$<br>Derate above $25^\circ\text{C}$ | $P_D$<br>(Note 2) | 300<br>2.4  | mW<br>mW/ $^\circ\text{C}$ |
| Thermal Resistance, Junction-to-Ambient  | $R_{\theta JA}$   | 625         | $^\circ\text{C}/\text{W}$  |
| Junction and Storage Temperature Range   | $T_J, T_{stg}$    | -55 to +150 | $^\circ\text{C}$           |

Maximum ratings are those values beyond which device damage can occur. Maximum ratings applied to the device are individual stress limit values (not normal operating conditions) and are not valid simultaneously. If these limits are exceeded, device functional operation is not implied, damage may occur and reliability may be affected.

- FR-5 = 1.0 X 0.75 X 0.062 in.
- Alumina = 0.4 X 0.3 X 0.024 in. 99.5% alumina



ON Semiconductor®

<http://onsemi.com>

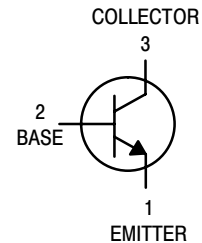

SC-59  
CASE 318D  
STYLE 1

#### MARKING DIAGRAM

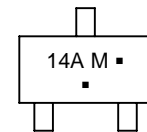

14A = Specific Device Code

M = Date Code\*

▪ = Pb-Free Package

(Note: Microdot may be in either location)

\*Date Code orientation may vary depending upon manufacturing location

#### ORDERING INFORMATION

| Device      | Package            | Shipping†          |
|-------------|--------------------|--------------------|
| MSD2714AT1  | SC-59              | 3000 / Tape & Reel |
| MSD2714AT1G | SC-59<br>(Pb-Free) | 3000 / Tape & Reel |

†For information on tape and reel specifications, including part orientation and tape sizes, please refer to our Tape and Reel Packaging Specifications Brochure, BRD8011/D.

Preferred devices are recommended choices for future use and best overall value.

# MSD2714AT1

## ELECTRICAL CHARACTERISTICS (T<sub>A</sub> = 25°C unless otherwise noted)

| Characteristic   | Symbol               | Min | Typ | Max  | Unit             |
|--|----------------------|-----|-----|------|------------------|
| <b>OFF CHARACTERISTICS</b>   |                      |     |     |      |                  |
| Collector–Emitter Breakdown Voltage<br>(I <sub>C</sub> = 1.0 mA <sub>dc</sub> , I <sub>B</sub> = 0)                              | V <sub>(BR)CEO</sub> | 25  | –   | –    | V <sub>dc</sub>  |
| Collector–Base Breakdown Voltage<br>(I <sub>C</sub> = 10 μA <sub>dc</sub> , I <sub>E</sub> = 0)                                  | V <sub>(BR)CBO</sub> | 30  | –   | –    | V <sub>dc</sub>  |
| Emitter–Base Breakdown Voltage<br>(I <sub>E</sub> = 10 μA <sub>dc</sub> , I <sub>C</sub> = 0)                                    | V <sub>(BR)EBO</sub> | 3.0 | –   | –    | V <sub>dc</sub>  |
| Collector Cutoff Current<br>(V <sub>CB</sub> = 35 V <sub>dc</sub> , I <sub>E</sub> = 0)  | I <sub>CBO</sub>     | –   | –   | 500  | nA <sub>dc</sub> |
| Emitter Cutoff Current<br>(V <sub>EB</sub> = 3.5 V <sub>dc</sub> , I <sub>C</sub> = 0)   | I <sub>EBO</sub>     | –   | –   | 500  | nA <sub>dc</sub> |
| <b>ON CHARACTERISTICS</b>  |                      |     |     |      |                  |
| DC Current Gain<br>(I <sub>C</sub> = 1.0 mA <sub>dc</sub> , V <sub>CE</sub> = 6.0 V <sub>dc</sub> )                              | h <sub>FE</sub>      | 90  | –   | 180  | –                |
| Base–Emitter On Voltage<br>(I <sub>C</sub> = 4.0 mA <sub>dc</sub> , V <sub>CE</sub> = 10 V <sub>dc</sub> )                       | V <sub>BE</sub>      | –   | –   | 0.95 | V <sub>dc</sub>  |
| <b>SMALL-SIGNAL CHARACTERISTICS</b>  |                      |     |     |      |                  |
| Current–Gain – Bandwidth Product<br>(I <sub>C</sub> = 4.0 mA <sub>dc</sub> , V <sub>CE</sub> = 10 V <sub>dc</sub> , f = 100 MHz) | f <sub>T</sub>       | 650 | –   | –    | MHz              |
| Collector–Base Capacitance<br>(V <sub>CB</sub> = 10 V <sub>dc</sub> , I <sub>E</sub> = 0, f = 1.0 MHz)                           | C <sub>cb</sub>      | –   | –   | 0.7  | pF               |
| Common–Base Feedback Capacitance<br>(V <sub>CB</sub> = 10 V <sub>dc</sub> , I <sub>E</sub> = 0, f = 1.0 MHz)                     | C <sub>fb</sub>      | –   | –   | 0.65 | pF               |
| Collector Base Time Constant<br>(I <sub>C</sub> = 4.0 mA <sub>dc</sub> , V <sub>CB</sub> = 10 V <sub>dc</sub> , f = 31.8 MHz)    | rb'C <sub>c</sub>    | –   | –   | 9.0  | ps               |

## TYPICAL CHARACTERISTICS

### COMMON-BASE y PARAMETERS versus FREQUENCY

(V<sub>CB</sub> = 10 V<sub>dc</sub>, I<sub>C</sub> = 4.0 mA<sub>dc</sub>, T<sub>A</sub> = 25°C)

#### y<sub>ib</sub>, INPUT ADMITTANCE

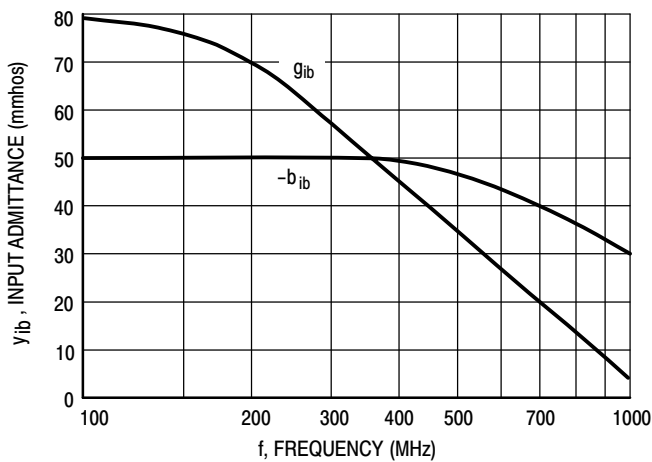

Figure 1. Rectangular Form

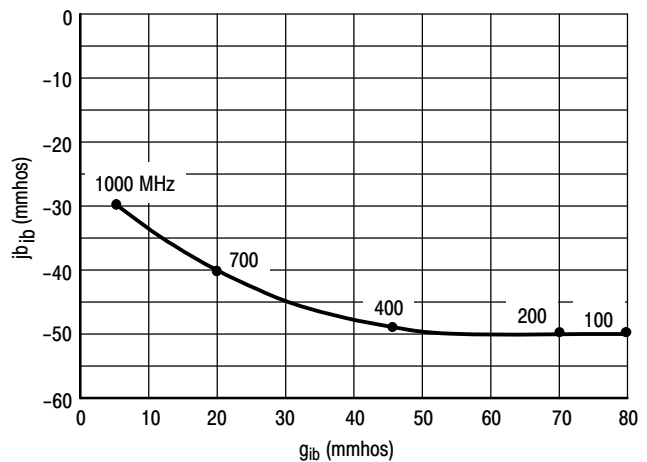

Figure 2. Polar Form

# MSD2714AT1

## TYPICAL CHARACTERISTICS

### $y_{fb}$ , FORWARD TRANSFER ADMITTANCE

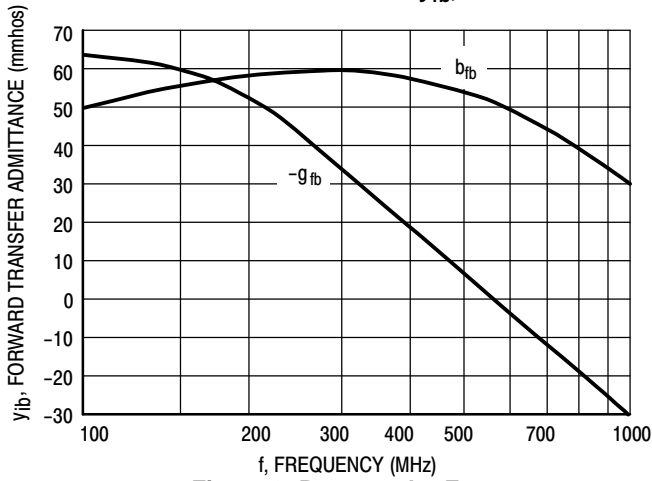

Figure 3. Rectangular Form

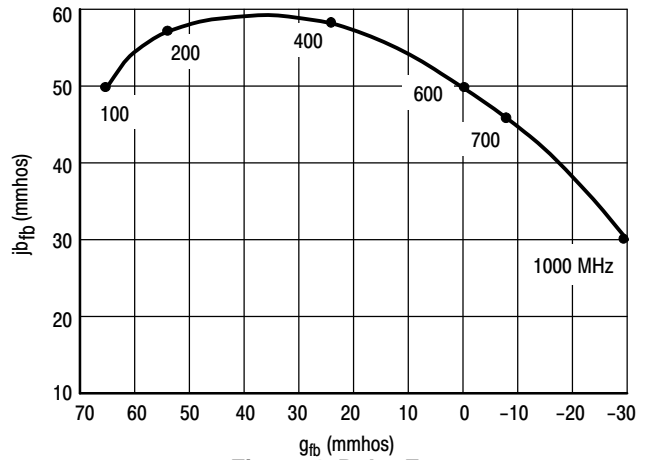

Figure 4. Polar Form

### COMMON-BASE $y$ PARAMETERS versus FREQUENCY

( $V_{CB} = 10$  Vdc,  $I_C = 4.0$  mAdc,  $T_A = 25^\circ\text{C}$ )

### $y_{rb}$ , REVERSE TRANSFER ADMITTANCE

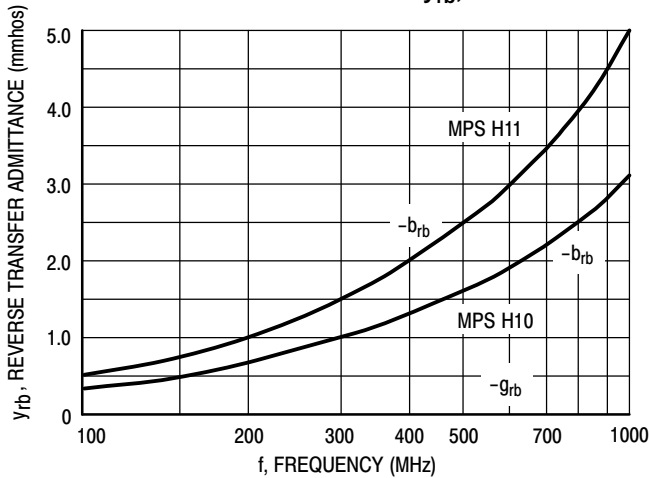

Figure 5. Rectangular Form

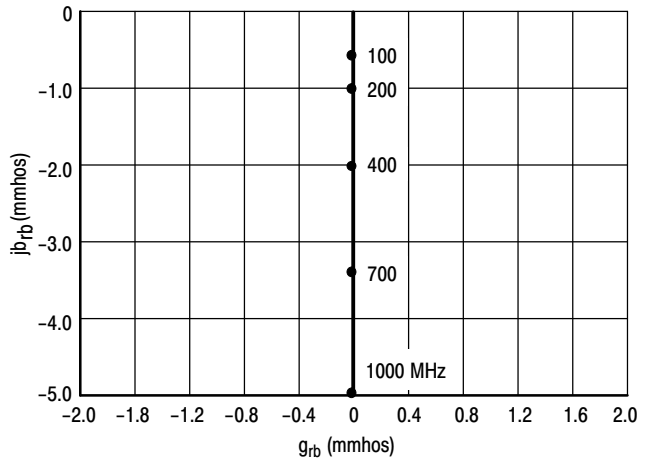

Figure 6. Polar Form

### $y_{ob}$ , OUTPUT ADMITTANCE

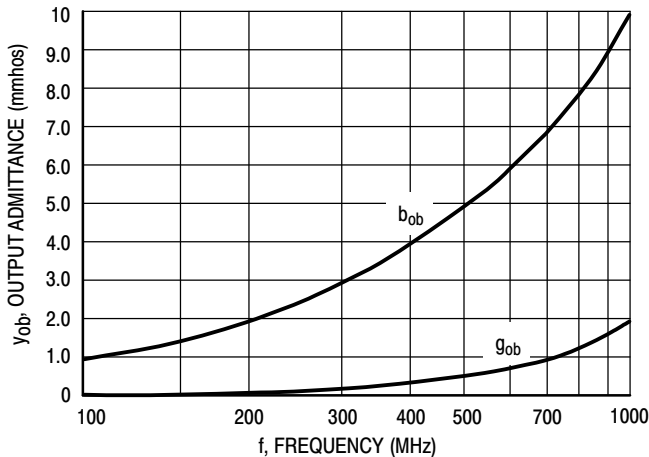

Figure 7. Rectangular Form

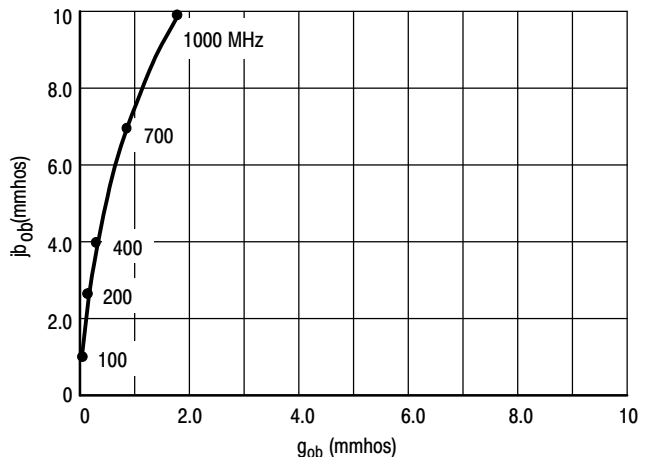
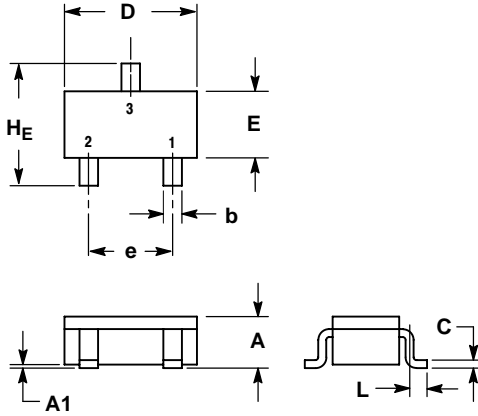

Figure 8. Polar Form

# MSD2714AT1

## PACKAGE DIMENSIONS

SC-59  
CASE 318D-04  
ISSUE G



NOTES:

1. DIMENSIONING AND TOLERANCING PER ANSI Y14.5M, 1982.
2. CONTROLLING DIMENSION: MILLIMETER.

| DIM | MILLIMETERS |      |      | INCHES |       |       |
|-----|-------------|------|------|--------|-------|-------|
|     | MIN         | NOM  | MAX  | MIN    | NOM   | MAX   |
| A   | 1.00        | 1.15 | 1.30 | 0.039  | 0.045 | 0.051 |
| A1  | 0.01        | 0.06 | 0.10 | 0.001  | 0.002 | 0.004 |
| b   | 0.35        | 0.43 | 0.50 | 0.014  | 0.017 | 0.020 |
| c   | 0.09        | 0.14 | 0.18 | 0.003  | 0.005 | 0.007 |
| D   | 2.70        | 2.90 | 3.10 | 0.106  | 0.114 | 0.122 |
| E   | 1.30        | 1.50 | 1.70 | 0.051  | 0.059 | 0.067 |
| e   | 1.70        | 1.90 | 2.10 | 0.067  | 0.075 | 0.083 |
| L   | 0.20        | 0.40 | 0.60 | 0.008  | 0.016 | 0.024 |
| HE  | 2.50        | 2.80 | 3.00 | 0.099  | 0.110 | 0.118 |

STYLE 1:

1. EMITTER
2. BASE
3. COLLECTOR

### SOLDERING FOOTPRINT\*

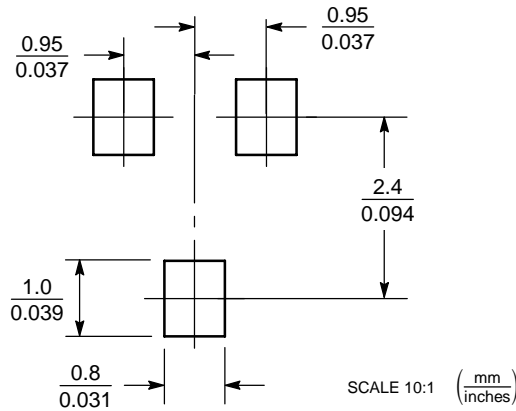

\*For additional information on our Pb-Free strategy and soldering details, please download the ON Semiconductor Soldering and Mounting Techniques Reference Manual, SOLDERRM/D.

ON Semiconductor and  are registered trademarks of Semiconductor Components Industries, LLC (SCILLC). SCILLC reserves the right to make changes without further notice to any products herein. SCILLC makes no warranty, representation or guarantee regarding the suitability of its products for any particular purpose, nor does SCILLC assume any liability arising out of the application or use of any product or circuit, and specifically disclaims any and all liability, including without limitation special, consequential or incidental damages. "Typical" parameters which may be provided in SCILLC data sheets and/or specifications can and do vary in different applications and actual performance may vary over time. All operating parameters, including "Typicals" must be validated for each customer application by customer's technical experts. SCILLC does not convey any license under its patent rights nor the rights of others. SCILLC products are not designed, intended, or authorized for use as components in systems intended for surgical implant into the body, or other applications intended to support or sustain life, or for any other application in which the failure of the SCILLC product could create a situation where personal injury or death may occur. Should Buyer purchase or use SCILLC products for any such unintended or unauthorized application, Buyer shall indemnify and hold SCILLC and its officers, employees, subsidiaries, affiliates, and distributors harmless against all claims, costs, damages, and expenses, and reasonable attorney fees arising out of, directly or indirectly, any claim of personal injury or death associated with such unintended or unauthorized use, even if such claim alleges that SCILLC was negligent regarding the design or manufacture of the part. SCILLC is an Equal Opportunity/Affirmative Action Employer. This literature is subject to all applicable copyright laws and is not for resale in any manner.

### PUBLICATION ORDERING INFORMATION

**LITERATURE FULFILLMENT:**

Literature Distribution Center for ON Semiconductor  
P.O. Box 61312, Phoenix, Arizona 85082-1312 USA  
Phone: 480-829-7710 or 800-344-3860 Toll Free USA/Canada  
Fax: 480-829-7709 or 800-344-3867 Toll Free USA/Canada  
Email: orderlit@onsemi.com

**N. American Technical Support:** 800-282-9855 Toll Free  
USA/Canada

**Japan:** ON Semiconductor, Japan Customer Focus Center  
2-9-1 Kamimeguro, Meguro-ku, Tokyo, Japan 153-0051  
Phone: 81-3-5773-3850

**ON Semiconductor Website:** <http://onsemi.com>

**Order Literature:** <http://www.onsemi.com/litorder>

For additional information, please contact your local Sales Representative.

## Looking for pricing, stock, or lifecycle information?

Click below to explore more details on WIN SOURCE:

 [View MSD2714AT1](#) on WIN SOURCE

 [ON Semiconductor](#) Information

## Optimize Your Supply Chain with WIN SOURCE Solutions

-  Global Sourcing Solution
-  Obsolete Management
-  Cost Control Management
-  Shortage Management
-  Alternative Solution
-  Excess Inventory Management