



THE DATASHEET OF MSP430F2616TPMR



MIXED SIGNAL MICROCONTROLLER

FEATURES

- Low Supply Voltage Range 1.8 V to 3.6 V
- Ultra-Low Power Consumption
 - Active Mode: 365 μ A at 1 MHz, 2.2 V
 - Standby Mode (VLO): 0.5 μ A
 - Off Mode (RAM Retention): 0.1 μ A
- Wake-Up From Standby Mode in Less Than 1 μ s
- 16-Bit RISC Architecture, 62.5-ns Instruction Cycle Time
- Three-Channel Internal DMA
- 12-Bit Analog-to-Digital (A/D) Converter With Internal Reference, Sample-and-Hold, and Autoscan Feature
- Dual 12-Bit Digital-to-Analog (D/A) Converters With Synchronization
- 16-Bit Timer_A With Three Capture/Compare Registers
- 16-Bit Timer_B With Seven Capture/Compare-With-Shadow Registers
- On-Chip Comparator
- Four Universal Serial Communication Interfaces (USCIs)
 - USCI_A0 and USCI_A1
 - Enhanced UART Supporting Auto-Baudrate Detection
 - IrDA Encoder and Decoder
 - Synchronous SPI
 - USCI_B0 and USCI_B1
 - I²C™
 - Synchronous SPI
- Supply Voltage Supervisor/Monitor With Programmable Level Detection
- Brownout Detector
- Bootstrap Loader
- Serial Onboard Programming, No External Programming Voltage Needed, Programmable Code Protection by Security Fuse
- Family Members:
 - MSP430F2416
 - 92KB + 256B Flash Memory
 - 4KB RAM
 - MSP430F2417
 - 92KB + 256B Flash Memory
 - 8KB RAM
 - MSP430F2418
 - 116KB + 256B Flash Memory
 - 8KB RAM
 - MSP430F2419
 - 120KB + 256B Flash Memory
 - 4KB RAM
 - MSP430F2616
 - 92KB + 256B Flash Memory
 - 4KB RAM
 - MSP430F2617
 - 92KB + 256B Flash Memory
 - 8KB RAM
 - MSP430F2618
 - 116KB + 256B Flash Memory
 - 8KB RAM
 - MSP430F2619
 - 120KB + 256B Flash Memory
 - 4KB RAM
- Available in 80-Pin Quad Flat Pack (LQFP), 64-Pin LQFP, and 113-Pin Ball Grid Array (BGA) (See [Table 1](#))
- For Complete Module Descriptions, See the *MSP430x2xx Family User's Guide* ([SLAU144](#))



Please be aware that an important notice concerning availability, standard warranty, and use in critical applications of Texas Instruments semiconductor products and disclaimers thereto appears at the end of this data sheet.



This integrated circuit can be damaged by ESD. Texas Instruments recommends that all integrated circuits be handled with appropriate precautions. Failure to observe proper handling and installation procedures can cause damage.

ESD damage can range from subtle performance degradation to complete device failure. Precision integrated circuits may be more susceptible to damage because very small parametric changes could cause the device not to meet its published specifications.

DESCRIPTION

The Texas Instruments MSP430 family of ultralow-power microcontrollers consists of several devices featuring different sets of peripherals targeted for various applications. The architecture, combined with five low-power modes is optimized to achieve extended battery life in portable measurement applications. The device features a powerful 16-bit RISC CPU, 16-bit registers, and constant generators that contribute to maximum code efficiency. The calibrated digitally controlled oscillator (DCO) allows wake-up from low-power modes to active mode in less than 1 μ s.

The MSP430F261x and MSP430F241x series are microcontroller configurations with two built-in 16-bit timers, a fast 12-bit A/D converter, a comparator, dual 12-bit D/A converters, four universal serial communication interface (USCI) modules, DMA, and up to 64 I/O pins. The MSP430F241x devices are identical to the MSP430F261x devices, with the exception that the DAC12 and the DMA modules are not implemented.

Typical applications include sensor systems, industrial control applications, and hand-held meters. The 12mmx12mm LQFP-64 package is also available as a non-magnetic package for medical imaging applications.

Table 1. Available Options⁽¹⁾

T _A	PACKAGED DEVICES ⁽²⁾		
	PLASTIC 113-PIN BGA (ZQW)	PLASTIC 80-PIN LQFP (PN)	PLASTIC 64-PIN LQFP (PM)
-40°C to 105°C	MSP430F2416TZQW MSP430F2417TZQW MSP430F2418TZQW MSP430F2419TZQW MSP430F2616TZQW MSP430F2617TZQW MSP430F2618TZQW MSP430F2619TZQW	MSP430F2416TPN MSP430F2417TPN MSP430F2418TPN MSP430F2419TPN MSP430F2616TPN MSP430F2617TPN MSP430F2618TPN MSP430F2619TPN	MSP430F2416TPM MSP430F2417TPM MSP430F2418TPM MSP430F2419TPM MSP430F2616TPM MSP430F2617TPM MSP430F2618TPM MSP430F2619TPM MSP430F2618TPMR-NM

(1) For the most current package and ordering information, see the Package Option Addendum at the end of this document, or see the TI web site at www.ti.com.

(2) Package drawings, thermal data, and symbolization are available at www.ti.com/packaging.

Development Tool Support

All MSP430 microcontrollers include an Embedded Emulation Module (EEM) allowing advanced debugging and programming through easy-to-use development tools. Recommended hardware options include:

- Debugging and Programming Interface
 - MSP-FET430UIF (USB)
 - MSP-FET430PIF (Parallel Port)
- Debugging and Programming Interface with Target Board
 - MSP-FET430U64 (PM Package)
 - MSP-FET430U80 (PN Package)
- Standalone Target Board
 - MSP-TS430PM64
- Production Programmer
 - MSP-GANG430

Device Pinout, MSP430F241x, 80-Pin PN Package

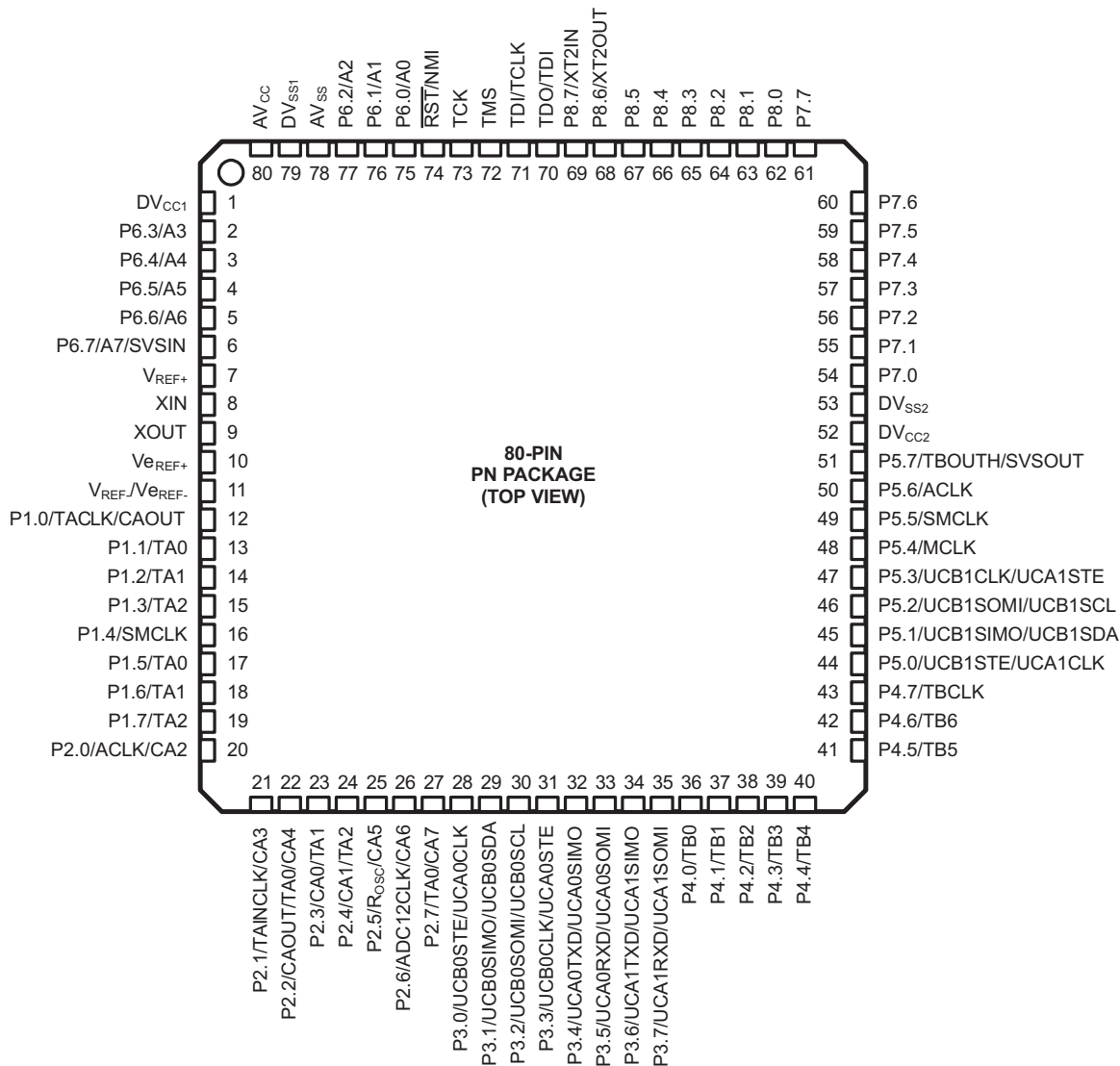

Device Pinout, MSP430F241x, 64-Pin PM Package

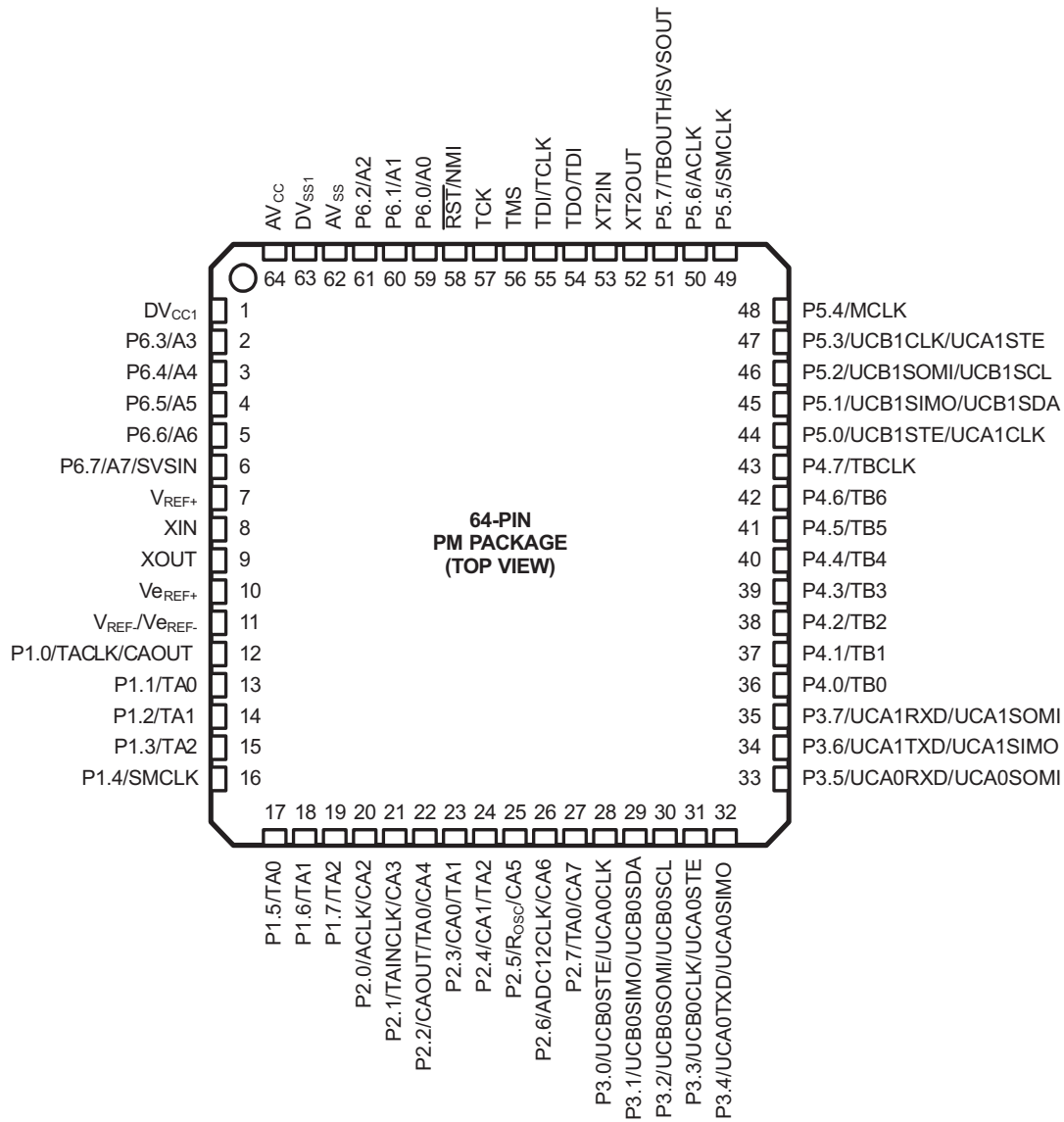

Device Pinout, MSP430F261x, 80-Pin PN Package

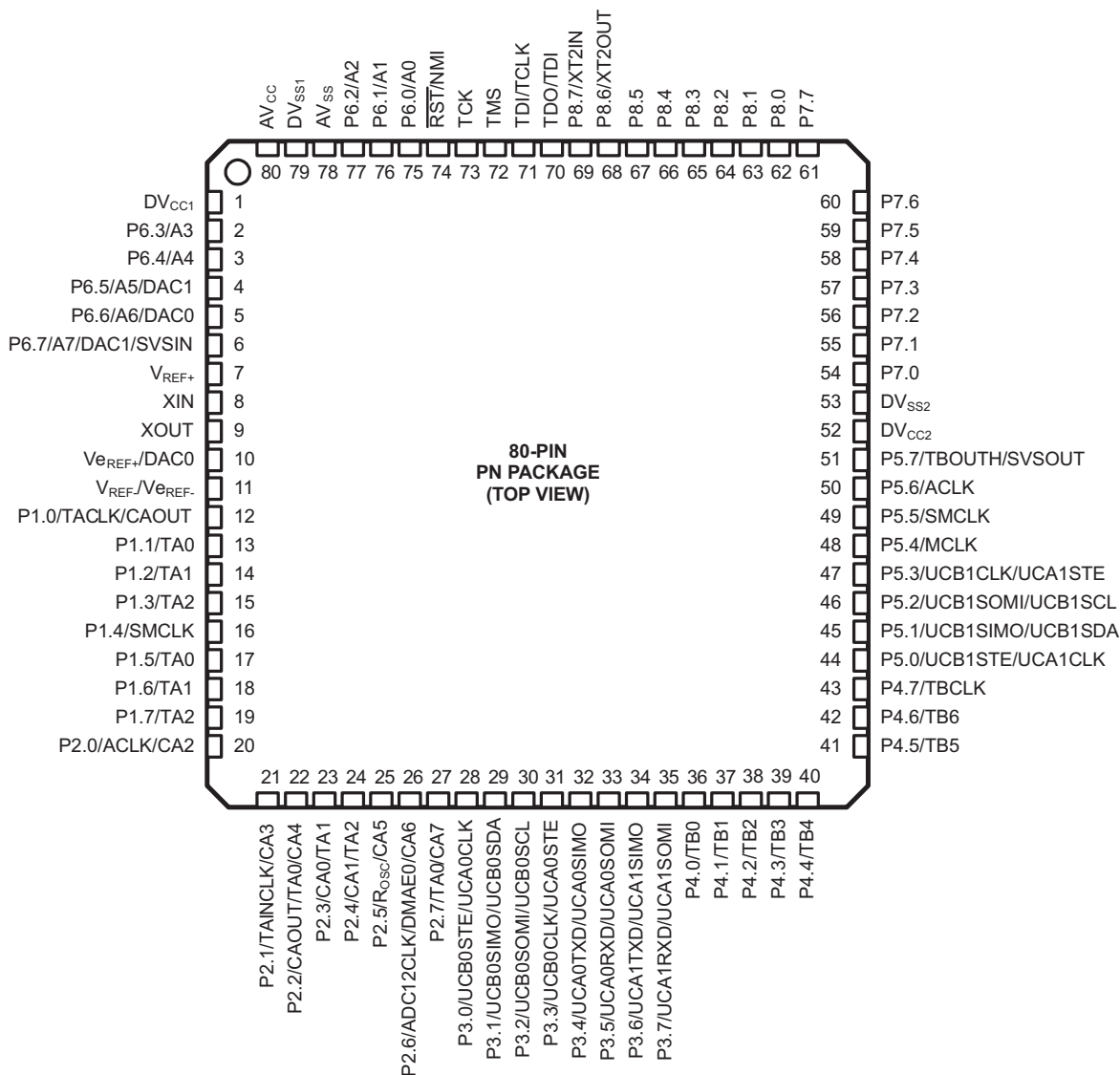

Device Pinout, MSP430F261x, 64-Pin PM Package

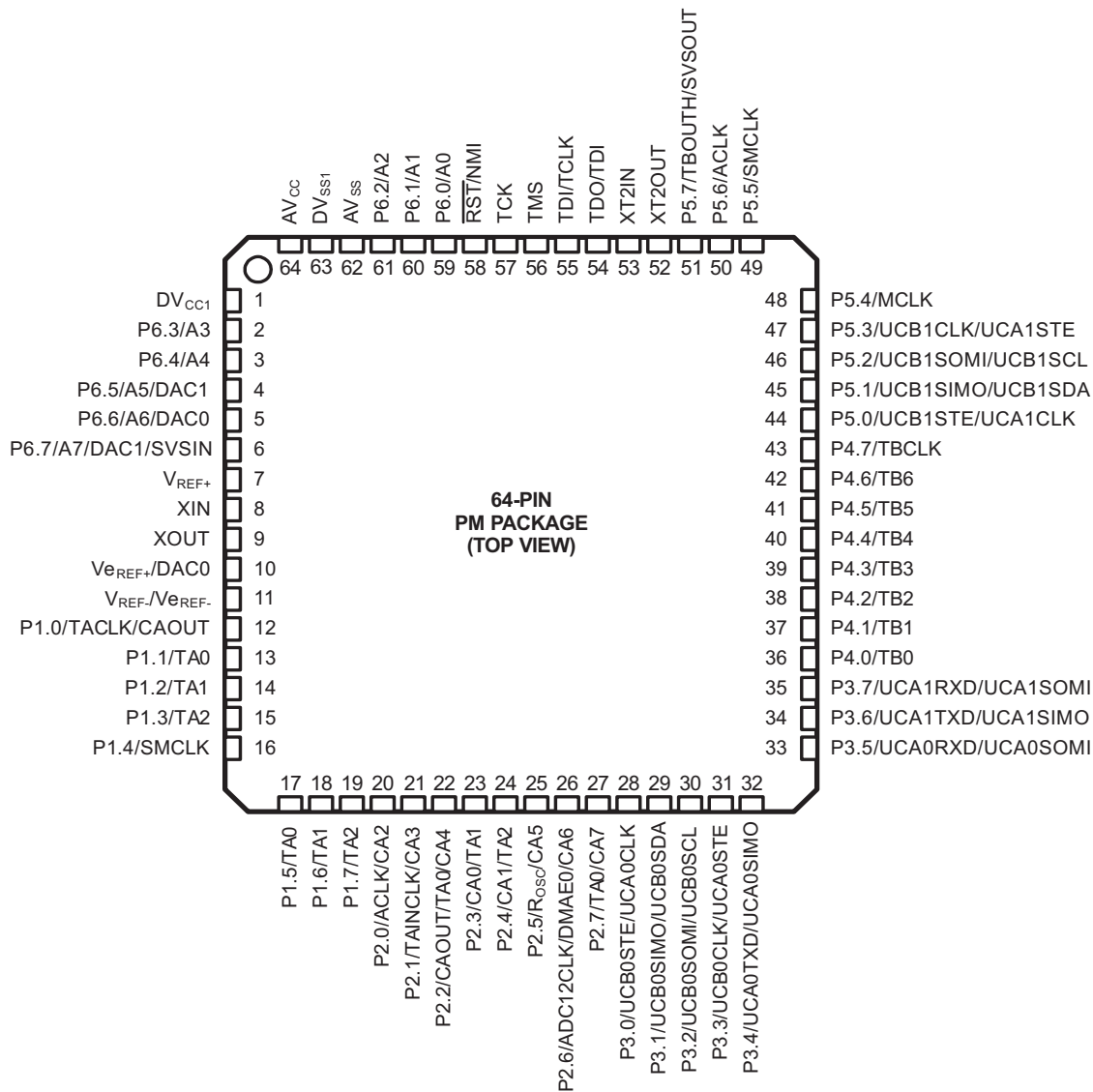

Device Pinout, 113-Pin ZQW Package

NOTE

For terminal assignments, see [Table 2](#).

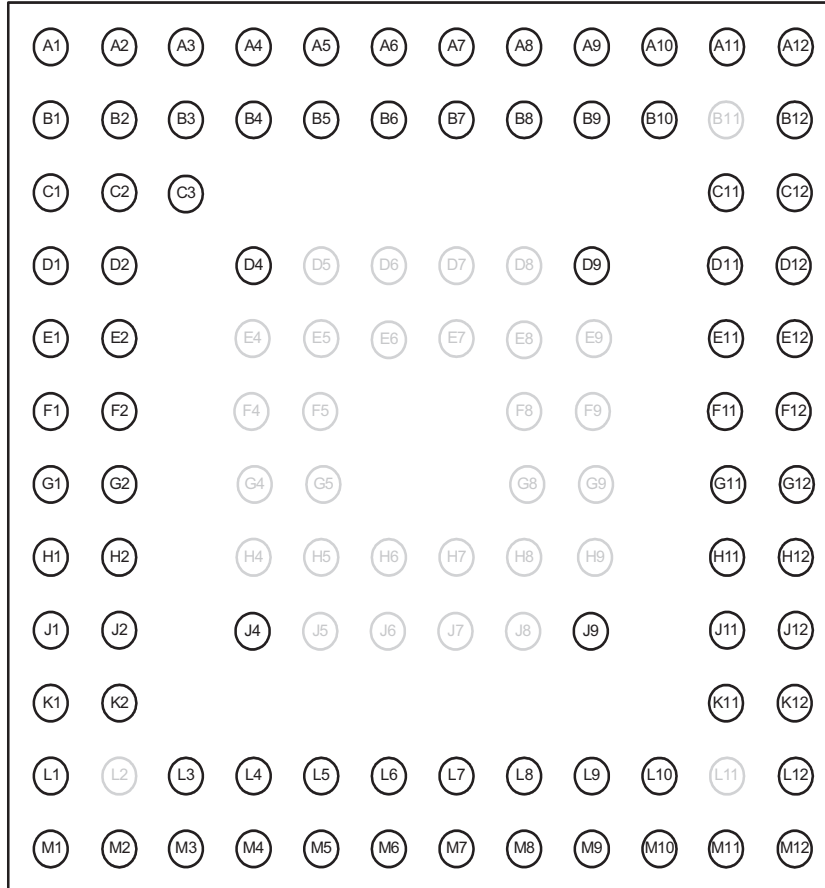

Functional Block Diagram, MSP430F241x, 80-Pin PN Package

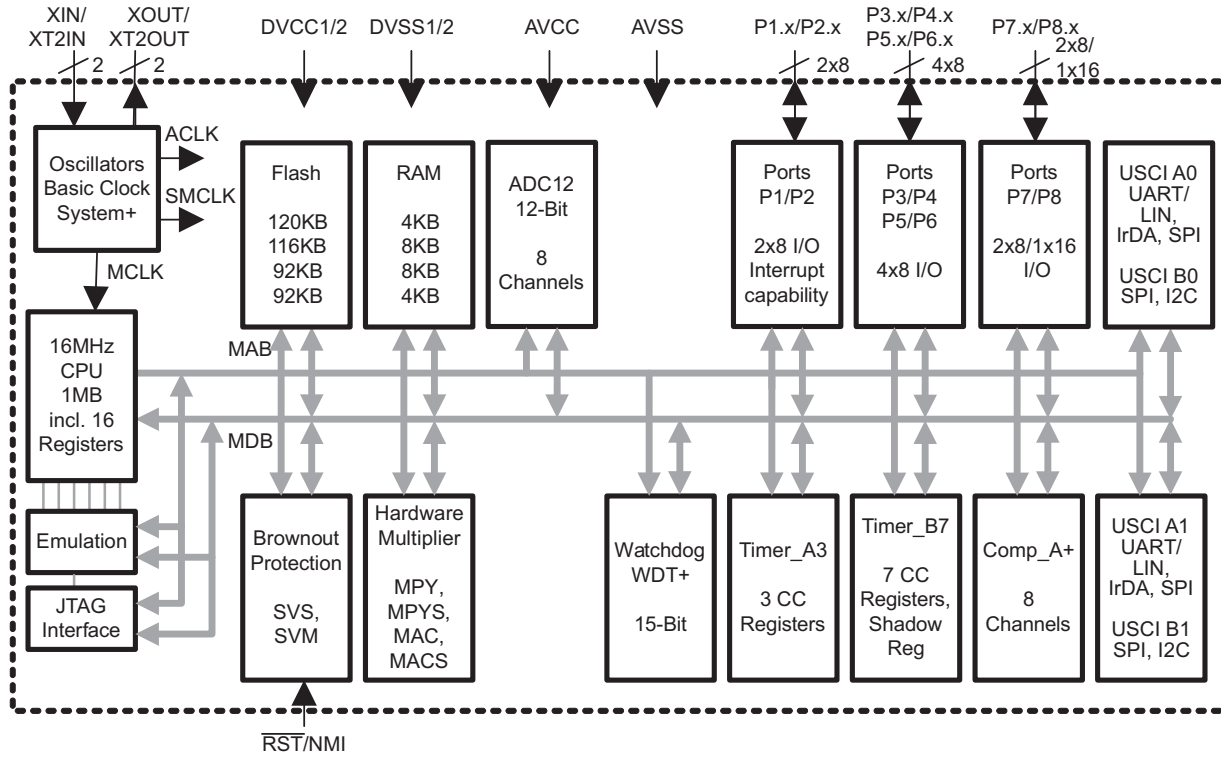

Functional Block Diagram, MSP430F241x, 64-Pin PM Package

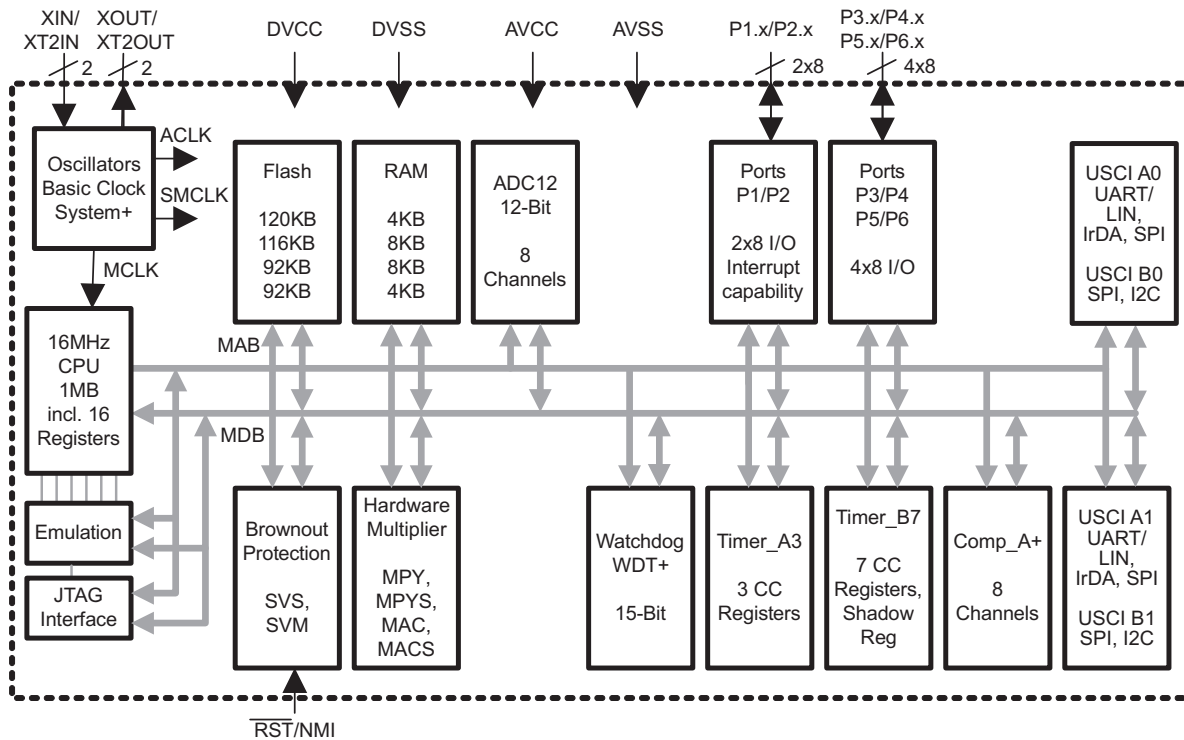

Functional Block Diagram, MSP430F261x, 80-Pin PN Package

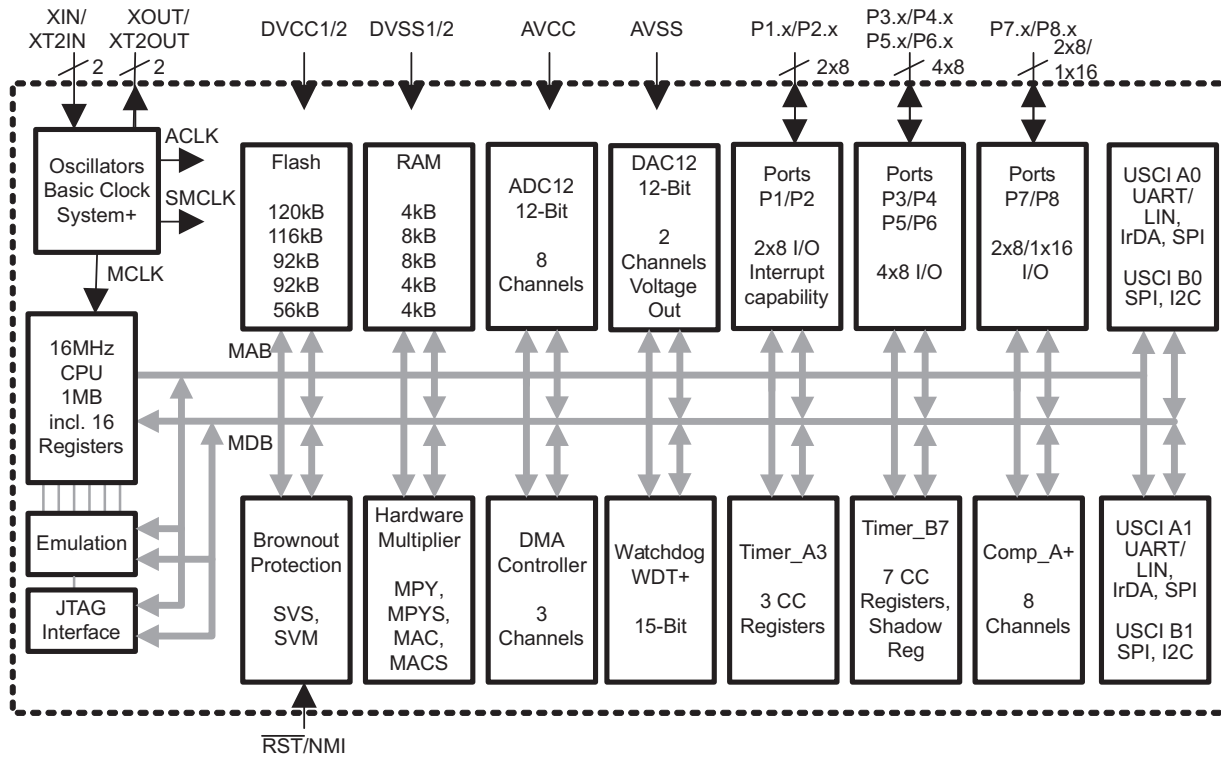

Functional Block Diagram, MSP430F261x, 64-Pin PM Package

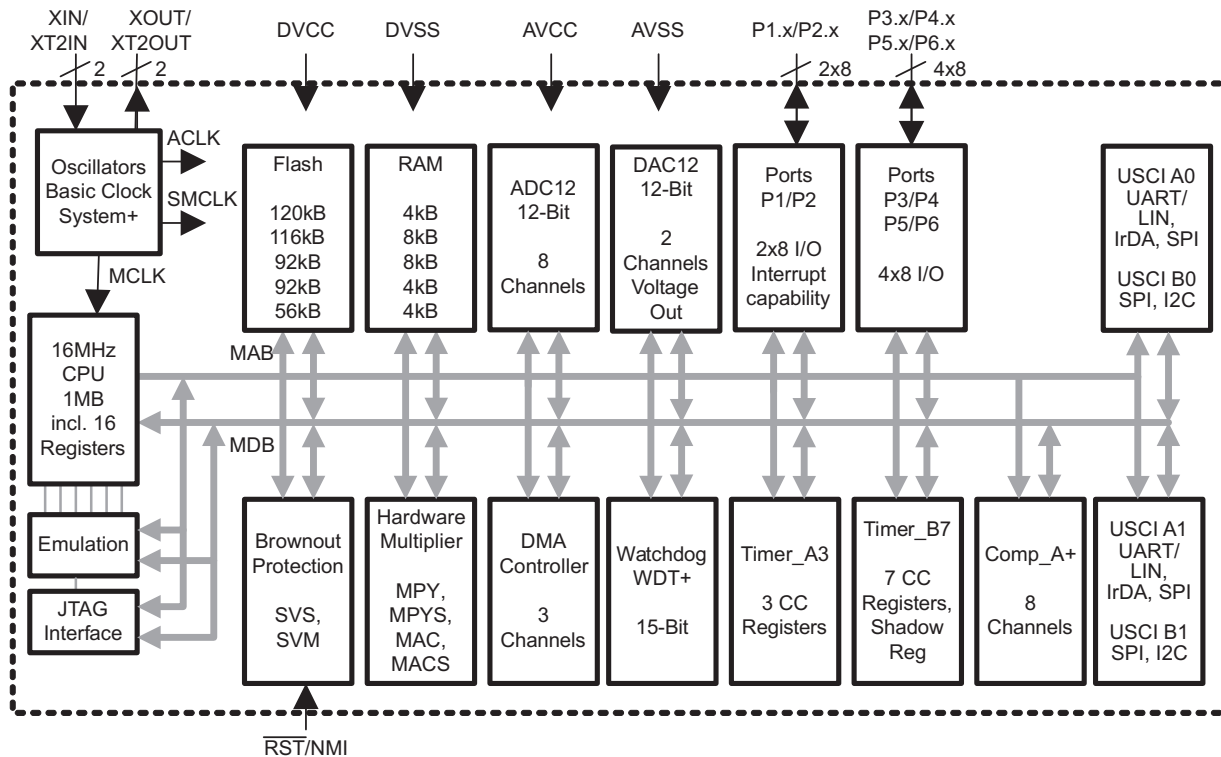

Table 2. Terminal Functions

TERMINAL				I/O	DESCRIPTION
NAME	NO.				
	64 PIN	80 PIN	113 PIN		
AV _{CC}	64	80	A2		Analog supply voltage, positive terminal. Supplies only the analog portion of ADC12 and DAC12.
AV _{SS}	62	78	B2, B3		Analog supply voltage, negative terminal. Supplies only the analog portion of ADC12 and DAC12.
DV _{CC1}	1	1	A1		Digital supply voltage, positive terminal. Supplies all digital parts.
DV _{SS1}	63	79	A3		Digital supply voltage, negative terminal. Supplies all digital parts.
DV _{CC2}		52	F12		Digital supply voltage, positive terminal. Supplies all digital parts.
DV _{SS2}		53	E12		Digital supply voltage, negative terminal. Supplies all digital parts.
P1.0/TACLK/CAOUT	12	12	G2	I/O	General-purpose digital I/O pin Timer_A, clock signal TACLK input Comparator_A output
P1.1/TA0	13	13	H1	I/O	General-purpose digital I/O pin Timer_A, capture: CCI0A input, compare: Out0 output BSL transmit
P1.2/TA1	14	14	H2	I/O	General-purpose digital I/O pin Timer_A, capture: CCI1A input, compare: Out1 output
P1.3/TA2	15	15	J1	I/O	General-purpose digital I/O pin Timer_A, capture: CCI2A input, compare: Out2 output
P1.4/SMCLK	16	16	J2	I/O	General-purpose digital I/O pin SMCLK signal output
P1.5/TA0	17	17	K1	I/O	General-purpose digital I/O pin Timer_A, compare: Out0 output
P1.6/TA1	18	18	K2	I/O	General-purpose digital I/O pin Timer_A, compare: Out1 output
P1.7/TA2	19	19	L1	I/O	General-purpose digital I/O pin Timer_A, compare: Out2 output
P2.0/ACLK/CA2	20	20	M1	I/O	General-purpose digital I/O pin ACLK output/Comparator_A input
P2.1/TAINCLK/CA3	21	21	M2	I/O	General-purpose digital I/O pin Timer_A, clock signal at INCLK
P2.2/CAOUT/TA0/CA4	22	22	M3	I/O	General-purpose digital I/O pin Timer_A, capture: CCI0B input Comparator_A output BSL receive Comparator_A input
P2.3/CA0/TA1	23	23	L3	I/O	General-purpose digital I/O pin Timer_A, compare: Out1 output Comparator_A input
P2.4/CA1/TA2	24	24	L4	I/O	General-purpose digital I/O pin Timer_A, compare: Out2 output Comparator_A input
P2.5/R _{OSC} /CA5	25	25	M4	I/O	General-purpose digital I/O pin Input for external resistor defining the DCO nominal frequency Comparator_A input

Table 2. Terminal Functions (continued)

TERMINAL				I/O	DESCRIPTION
NAME	NO.				
	64 PIN	80 PIN	113 PIN		
P2.6/ADC12CLK/ DMAE0 ⁽¹⁾ /CA6	26	26	J4	I/O	General-purpose digital I/O pin Conversion clock - 12-bit ADC DMA channel 0 external trigger Comparator_A input
P2.7/TA0/CA7	27	27	L5	I/O	General-purpose digital I/O pin Timer_A, compare: Out0 output Comparator_A input
P3.0/UCB0STE/ UCA0CLK	28	28	M5	I/O	General-purpose digital I/O pin USCI_B0 slave transmit enable/USCI_A0 clock input/output
P3.1/UCB0SIMO/ UCB0SDA	29	29	L6	I/O	General-purpose digital I/O pin USCI_B0 slave-in master-out in SPI mode, SDA I2C data in I2C mode
P3.2/UCB0SOMI/ UCB0SCL	30	30	M6	I/O	General-purpose digital I/O pin USCI_B0 slave-out master-in in SPI mode, SCL I2C clock in I2C mode
P3.3/UCB0CLK/ UCA0STE	31	31	L7	I/O	General-purpose digital I/O USCI_B0 clock input/output, USCI_A0 slave transmit enable
P3.4/UCA0TXD/ UCA0SIMO	32	32	M7	I/O	General-purpose digital I/O pin USCI_A transmit data output in UART mode, slave data in/master out in SPI mode
P3.5/UCA0RXD/ UCA0SOMI	33	33	L8	I/O	General-purpose digital I/O pin USCI_A0 receive data input in UART mode, slave data out/master in in SPI mode
P3.6/UCA1TXD/ UCA1SIMO	34	34	M8	I/O	General-purpose digital I/O pin USCI_A1 transmit data output in UART mode, slave data in/master out in SPI mode
P3.7/UCA1RXD/ UCA1SOMI	35	35	L9	I/O	General-purpose digital I/O pin USCI_A1 receive data input in UART mode, slave data out/master in in SPI mode
P4.0/TB0	36	36	M9	I/O	General-purpose digital I/O pin Timer_B, capture: CCI0A/B input, compare: Out0 output
P4.1/TB1	37	37	J9	I/O	General-purpose digital I/O pin Timer_B, capture: CCI1A/B input, compare: Out1 output
P4.2/TB2	38	38	M10	I/O	General-purpose digital I/O pin Timer_B, capture: CCI2A/B input, compare: Out2 output
P4.3/TB3	39	39	L10	I/O	General-purpose digital I/O pin Timer_B, capture: CCI3A/B input, compare: Out3 output
P4.4/TB4	40	40	M11	I/O	General-purpose digital I/O pin Timer_B, capture: CCI4A/B input, compare: Out4 output
P4.5/TB5	41	41	M12	I/O	General-purpose digital I/O pin Timer_B, capture: CCI5A/B input, compare: Out5 output
P4.6/TB6	42	42	L12	I/O	General-purpose digital I/O pin Timer_B, capture: CCI6A input, compare: Out6 output
P4.7/TBCLK	43	43	K11	I/O	General-purpose digital I/O pin Timer_B, clock signal TBCLK input

(1) MSP430F261x devices only

Table 2. Terminal Functions (continued)

TERMINAL				I/O	DESCRIPTION
NAME	NO.				
	64 PIN	80 PIN	113 PIN		
P5.0/UCB1STE/ UCA1CLK	44	44	K12	I/O	General-purpose digital I/O pin USCI_B1 slave transmit enable/USCI_A1 clock input/output
P5.1/UCB1SIMO/ UCB1SDA	45	45	J11	I/O	General-purpose digital I/O pin USCI_B1 slave-in master-out in SPI mode, SDA I2C data in I2C mode
P5.2/UCB1SOMI/ UCB1SCL	46	46	J12	I/O	General-purpose digital I/O pin USCI_B1 slave-out master-in in SPI mode, SCL I2C clock in I2C mode
P5.3/UCB1CLK/ UCA1STE	47	47	H11	I/O	General-purpose digital I/O USCI_B1 clock input/output, USCI_A1 slave transmit enable
P5.4/MCLK	48	48	H12	I/O	General-purpose digital I/O pin Main system clock MCLK output
P5.5/SMCLK	49	49	G11	I/O	General-purpose digital I/O pin Submain system clock SMCLK output
P5.6/ACLK	50	50	G12	I/O	General-purpose digital I/O pin Auxiliary clock ACLK output
P5.7/TBOUTH/SVSOUT	51	51	F11	I/O	General-purpose digital I/O pin Switch all PWM digital output ports to high impedance - Timer_B TB0 to TB6 SVS comparator output
P6.0/A0	59	75	D4	I/O	General-purpose digital I/O pin Analog input A0 - 12-bit ADC
P6.1/A1	60	76	A4	I/O	General-purpose digital I/O pin Analog input A1 - 12-bit ADC
P6.2/A2	61	77	B4	I/O	General-purpose digital I/O pin Analog input A2 - 12-bit ADC
P6.3/A3	2	2	B1	I/O	General-purpose digital I/O pin Analog input A3 - 12-bit ADC
P6.4/A4	3	3	C1	I/O	General-purpose digital I/O pin Analog input A4 - 12-bit ADC
P6.5/A5/DAC1 ⁽²⁾	4	4	C2, C3	I/O	General-purpose digital I/O pin Analog input A5 - 12-bit ADC DAC12.1 output
P6.6/A6/DAC0 ⁽²⁾	5	5	D1	I/O	General-purpose digital I/O pin Analog input A6 - 12-bit ADC DAC12.0 output
P6.7/A7/DAC1 ⁽²⁾ /SVSIN	6	6	D2	I/O	General-purpose digital I/O pin Analog input A7 - 12-bit ADC DAC12.1 output SVS input
P7.0		54	E11	I/O	General-purpose digital I/O pin
P7.1		55	D12	I/O	General-purpose digital I/O pin
P7.2		56	D11	I/O	General-purpose digital I/O pin
P7.3		57	C12	I/O	General-purpose digital I/O pin
P7.4		58	C11	I/O	General-purpose digital I/O pin

(2) MSP430F261x devices only

Table 2. Terminal Functions (continued)

TERMINAL				I/O	DESCRIPTION
NAME	NO.				
	64 PIN	80 PIN	113 PIN		
P7.5		59	B12	I/O	General-purpose digital I/O pin
P7.6		60	A12	I/O	General-purpose digital I/O pin
P7.7		61	A11	I/O	General-purpose digital I/O pin
P8.0		62	B10	I/O	General-purpose digital I/O pin
P8.1		63	A10	I/O	General-purpose digital I/O pin
P8.2		64	D9	I/O	General-purpose digital I/O pin
P8.3		65	A9	I/O	General-purpose digital I/O pin
P8.4		66	B9	I/O	General-purpose digital I/O pin
P8.5		67	B8	I/O	General-purpose digital I/O pin
P8.6/XT2OUT		68	A8	I/O	General-purpose digital I/O pin Output terminal of crystal oscillator XT2
P8.7/XT2IN		69	A7	I/O	General-purpose digital I/O pin Input port for crystal oscillator XT2. Only standard crystals can be connected.
XT2OUT	52			O	Output terminal of crystal oscillator XT2
XT2IN	53			I	Input port for crystal oscillator XT2
RST/NMI	58	74	B5	I	Reset input, nonmaskable interrupt input port, or bootstrap loader start (in flash devices)
TCK	57	73	A5	I	Test clock (JTAG). TCK is the clock input port for device programming test and bootstrap loader start
TDI/TCLK	55	71	A6	I	Test data input or test clock input. The device protection fuse is connected to TDI/TCLK.
TDO/TDI	54	70	B7	I/O	Test data output port. TDO/TDI data output or programming data input terminal.
TMS	56	72	B6	I	Test mode select. TMS is used as an input port for device programming and test.
V _{REF+} /DAC0 ⁽³⁾	10	10	F2	I	Input for an external reference voltage/DAC12.0 output
V _{REF+}	7	7	E2	O	Output of positive terminal of the reference voltage in the ADC12
V _{REF-} /V _{REF-}	11	11	G1	I	Negative terminal for the reference voltage for both sources, the internal reference voltage or an external applied reference voltage
XIN	8	8	E1	I	Input port for crystal oscillator XT1. Standard or watch crystals can be connected.
XOUT	9	9	F1	O	Output port for crystal oscillator XT1. Standard or watch crystals can be connected.
Reserved	-	-	⁽⁴⁾	NA	Reserved pins. Connection to DV _{SS} , AV _{SS} recommended.

(3) MSP430F261x devices only

(4) Reserved pins are L2, E4, F4, G4, H4, D5, E5, F5, G5, H5, J5, D6, E6, H6, J6, D7, E7, H7, J7, D8, E8, F8, G8, H8, J8, E9, F9, G9, H9, B11, L11.

SHORT-FORM DESCRIPTION

CPU

The MSP430 CPU has a 16-bit RISC architecture that is highly transparent to the application. All operations, other than program-flow instructions, are performed as register operations in conjunction with seven addressing modes for source operand and four addressing modes for destination operand.

The CPU is integrated with 16 registers that provide reduced instruction execution time. The register-to-register operation execution time is one cycle of the CPU clock.

Four of the registers, R0 to R3, are dedicated as program counter, stack pointer, status register, and constant generator respectively. The remaining registers are general-purpose registers.

Peripherals are connected to the CPU using data, address, and control buses, and can be handled with all instructions.

Instruction Set

The instruction set consists of 51 instructions with three formats and seven address modes. Each instruction can operate on word and byte data. [Table 3](#) shows examples of the three types of instruction formats; [Table 4](#) shows the address modes.

Program Counter	PC/R0
Stack Pointer	SP/R1
Status Register	SR/CG1/R2
Constant Generator	CG2/R3
General-Purpose Register	R4
General-Purpose Register	R5
General-Purpose Register	R6
General-Purpose Register	R7
General-Purpose Register	R8
General-Purpose Register	R9
General-Purpose Register	R10
General-Purpose Register	R11
General-Purpose Register	R12
General-Purpose Register	R13
General-Purpose Register	R14
General-Purpose Register	R15

Table 3. Instruction Word Formats

INSTRUCTION FORMAT	EXAMPLE	OPERATION
Dual operands, source-destination	ADD R4,R5	R4 + R5 -> R5
Single operands, destination only	CALL R8	PC ->(TOS), R8-> PC
Relative jump, un/conditional	JNE	Jump-on-equal bit = 0

Table 4. Address Mode Descriptions

ADDRESS MODE	S ⁽¹⁾	D ⁽¹⁾	SYNTAX	EXAMPLE	OPERATION
Register	✓	✓	MOV Rs,Rd	MOV R10,R11	R10 -> R11
Indexed	✓	✓	MOV X(Rn),Y(Rm)	MOV 2(R5),6(R6)	M(2+R5)-> M(6+R6)
Symbolic (PC relative)	✓	✓	MOV EDE,TONI		M(EDE) -> M(TONI)
Absolute	✓	✓	MOV &MEM,&TCDAT		M(MEM) -> M(TCDAT)
Indirect	✓		MOV @Rn,Y(Rm)	MOV @R10,Tab(R6)	M(R10) -> M(Tab+R6)
Indirect autoincrement	✓		MOV @Rn+,Rm	MOV @R10+,R11	M(R10) -> R11 R10 + 2-> R10
Immediate	✓		MOV #X,TONI	MOV #45,TONI	#45 -> M(TONI)

(1) S = source, D = destination

Operating Modes

The MSP430 has one active mode and five software-selectable low-power modes of operation. An interrupt event can wake the device from any of the five low-power modes, service the request, and restore back to the low-power mode on return from the interrupt program.

The following six operating modes can be configured by software:

- Active mode (AM)
 - All clocks are active
- Low-power mode 0 (LPM0)
 - CPU is disabled
 - ACLK and SMCLK remain active
 - MCLK is disabled
- Low-power mode 1 (LPM1)
 - CPU is disabled
 - ACLK and SMCLK remain active. MCLK is disabled
 - DCO's dc-generator is disabled if DCO not used in active mode
- Low-power mode 2 (LPM2)
 - CPU is disabled
 - MCLK and SMCLK are disabled
 - DCO's dc-generator remains enabled
 - ACLK remains active
- Low-power mode 3 (LPM3)
 - CPU is disabled
 - MCLK and SMCLK are disabled
 - DCO's dc-generator is disabled
 - ACLK remains active
- Low-power mode 4 (LPM4)
 - CPU is disabled
 - ACLK is disabled
 - MCLK and SMCLK are disabled
 - DCO's dc-generator is disabled
 - Crystal oscillator is stopped

Interrupt Vector Addresses

The interrupt vectors and the power-up starting address are located in the address range of 0FFFFh to 0FFC0h. The vector contains the 16-bit address of the appropriate interrupt handler instruction sequence.

If the reset vector (located at address 0FFFEh) contains 0FFFFh (for example, flash is not programmed) the CPU enters LPM4 immediately after power-up.

Table 5. Interrupt Sources

INTERRUPT SOURCE	INTERRUPT FLAG	SYSTEM INTERRUPT	WORD ADDRESS	PRIORITY
Power-up External reset Watchdog Timer+ Flash key violation PC out-of-range ⁽¹⁾	PORIFG RSTIFG WDTIFG KEYV See ⁽²⁾	Reset	0FFFEh	31, highest
NMI Oscillator fault Flash memory access violation	NMIIFG OFIFG ACCVIFG ⁽²⁾⁽³⁾	(Non)maskable, (Non)maskable, (Non)maskable	0FFFCh	30
Timer_B7	TBCCR0 CCIFG ⁽⁴⁾	Maskable	0FFFAh	29
Timer_B7	TBCCR1 to TBCCR6 CCIFGs, TBIFG ⁽²⁾⁽⁴⁾	Maskable	0FFF8h	28
Comparator_A+	CAIFG	Maskable	0FFF6h	27
Watchdog Timer+	WDTIFG	Maskable	0FFF4h	26
Timer_A3	TACCR0 CCIFG ⁽⁴⁾	Maskable	0FFF2h	25
Timer_A3	TACCR1 CCIFG TACCR2 CCIFG ⁽²⁾⁽⁴⁾	Maskable	0FFF0h	24
USCI_A0/USCI_B0 receive USCI_B0 I2C status	UCA0RXIFG, UCB0RXIFG ⁽²⁾⁽⁵⁾	Maskable	0FFEEh	23
USCI_A0/USCI_B0 transmit USCI_B0 I2C receive or transmit	UCA0TXIFG, UCB0TXIFG ⁽²⁾⁽⁶⁾	Maskable	0FFECh	22
ADC12	ADC12IFG ⁽²⁾⁽⁴⁾	Maskable	0FFEAh	21
			0FFE8h	20
I/O port P2 (eight flags)	P2IFG.0 to P2IFG.7 ⁽²⁾⁽⁴⁾	Maskable	0FFE6h	19
I/O port P1 (eight flags)	P1IFG.0 to P1IFG.7 ⁽²⁾⁽⁴⁾	Maskable	0FFE4h	18
USCI_A1/USCI_B1 receive USCI_B1 I2C status	UCA1RXIFG, UCB1RXIFG ⁽²⁾⁽⁵⁾	Maskable	0FFE2h	17
USCI_A1/USCI_B1 transmit USCI_B1 I2C receive or transmit	UCA1TXIFG, UCB1TXIFG ⁽²⁾⁽⁶⁾	Maskable	0FFE0h	16
DMA	DMA0IFG, DMA1IFG, DMA2IFG ⁽²⁾⁽⁴⁾	Maskable	0FFDEh	15
DAC12	DAC12_0IFG, DAC12_1IFG ⁽²⁾⁽⁴⁾	Maskable	0FFDCh	14
See ⁽⁷⁾⁽⁸⁾			0FFDAh to 0FFC0h	15 to 0, lowest

- (1) A reset is generated if the CPU tries to fetch instructions from within the module register memory address range (0h to 01FFh) or from within unused address ranges.
- (2) Multiple source flags
- (3) (Non)maskable: the individual interrupt-enable bit can disable an interrupt event, but the general interrupt enable cannot.
- (4) Interrupt flags are located in the module.
- (5) In SPI mode: UCB0RXIFG. In I2C mode: UCALIFG, UCNACKIFG, ICSTTIFG, UCSTPIFG.
- (6) In UART/SPI mode: UCB0TXIFG. In I2C mode: UCB0RXIFG, UCB0TXIFG.
- (7) The address 0FFBEh is used as bootstrap loader security key (BSLSKEY).
A 0AA55h at this location disables the BSL completely.
A zero disables the erasure of the flash if an invalid password is supplied.
- (8) The interrupt vectors at addresses 0FFDAh to 0FFC0h are not used in this device and can be used for regular program code if necessary.

Special Function Registers

Most interrupt and module enable bits are collected into the lowest address space. Special function register bits not allocated to a functional purpose are not physically present in the device. Simple software access is provided with this arrangement.









Legend	rw:	Bit can be read and written.
	rw-0,1:	Bit can be read and written. It is reset or set by PUC.
	rw-(0,1):	Bit can be read and written. It is reset or set by POR.
		SFR bit is not present in device.

Table 6. Interrupt Enable Register 1 and 2



Address	7	6	5	4	3	2	1	0
00h			ACCVIE	NMIIE			OFIE	WDTIE
			rw-0	rw-0			rw-0	rw-0

WDTIE	Watchdog Timer interrupt enable. Inactive if watchdog mode is selected. Active if Watchdog Timer is configured in interval timer mode.
OFIE	Oscillator fault interrupt enable
NMIIE	(Non)maskable interrupt enable
ACCVIE	Flash access violation interrupt enable





Address	7	6	5	4	3	2	1	0
01h					UCB0TXIE	UCB0RXIE	UCA0TXIE	UCA0RXIE
					rw-0	rw-0	rw-0	rw-0

UCA0RXIE	USCI_A0 receive interrupt enable
UCA0TXIE	USCI_A0 transmit interrupt enable
UCB0RXIE	USCI_B0 receive interrupt enable
UCB0TXIE	USCI_B0 transmit interrupt enable

Table 7. Interrupt Flag Register 1 and 2

Address	7	6	5	4	3	2	1	0
02h				NMIIFG	RSTIFG	PORIFG	OFIFG	WDTIFG
				rw-0	rw-(0)	rw-(1)	rw-1	rw-(0)

WDTIFG	Set on watchdog timer overflow (in watchdog mode) or security key violation. Reset on V _{CC} power-on or a reset condition at the $\overline{\text{RST}}$ /NMI pin in reset mode.
OFIFG	Flag set on oscillator fault.
PORIFG	Power-On Reset interrupt flag. Set on V _{CC} power-up.
RSTIFG	External reset interrupt flag. Set on a reset condition at $\overline{\text{RST}}$ /NMI pin in reset mode. Reset on V _{CC} power-up.
NMIIFG	Set via $\overline{\text{RST}}$ /NMI pin

Address	7	6	5	4	3	2	1	0
03h					UCB0TXIFG	UCB0RXIFG	UCA0TXIFG	UCA0RXIFG
					rw-1	rw-0	rw-1	rw-0

UCA0RXIFG	USCI_A0 receive interrupt flag
UCA0TXIFG	USCI_A0 transmit interrupt flag
UCB0RXIFG	USCI_B0 receive interrupt flag
UCB0TXIFG	USCI_B0 transmit interrupt flag

Memory Organization

Table 8. Memory Organization

		MSP430F2416 MSP430F2616	MSP430F2417 MSP430F2617	MSP430F2418 MSP430F2618	MSP430F2419 MSP430F2619
Memory	Size	92KB	92KB	116KB	120KB
Main: interrupt vector	Flash	0x0FFFF-0x0FFC0	0x0FFFF-0x0FFC0	0x0FFFF-0x0FFC0	0x0FFFF-0x0FFC0
Main: code memory	Flash	0x18FFF-0x02100	0x19FFF-0x03100	0x1FFFF-0x03100	0x1FFFF-0x02100
RAM (total)	Size	4KB 0x020FF-0x01100	8KB 0x030FF-0x01100	8KB 0x030FF-0x01100	4KB 0x020FF-0x01100
Extended	Size	2KB 0x020FF-0x01900	6KB 0x030FF-0x01900	6KB 0x030FF-0x01900	2KB 0x020FF-0x01900
Mirrored	Size	2KB 0x018FF-0x01100	2KB 0x018FF-0x01100	2KB 0x018FF-0x01100	2KB 0x018FF-0x01100
Information memory	Size	256 Byte	256 Byte	256 Byte	256 Byte
	Flash	0x010FF-0x01000	0x010FF-0x01000	0x010FF-0x01000	0x010FF-0x01000
Boot memory	Size	1KB	1KB	1KB	1KB
	ROM	0x00FFF-0x00C00	0x00FFF-0x00C00	0x00FFF-0x00C00	0x00FFF-0x00C00
RAM (mirrored at 0x18FF to 0x01100)	Size	2KB 0x009FF-0x00200	2KB 0x009FF-0x00200	2KB 0x009FF-0x00200	2KB 0x009FF-0x00200
Peripherals	16-bit	0x001FF-0x00100	0x001FF-0x00100	0x001FF-0x00100	0x001FF-0x00100
	8-bit	0x000FF-0x00010	0x000FF-0x00010	0x000FF-0x00010	0x000FF-0x00010
	8-bit SFR	0x0000F-0x00000	0x0000F-0x00000	0x0000F-0x00000	0x0000F-0x00000

Bootstrap Loader (BSL)

The MSP430 BSL enables users to program the flash memory or RAM using a UART serial interface. Access to the MSP430 memory via the BSL is protected by a user-defined password. For complete description of the features of the BSL and its implementation, see the *MSP430 Programming Via the Bootstrap Loader (BSL) User's Guide (SLAU319)*.

Table 9. BSL Pin Functions

BSL FUNCTION	PM, PN PACKAGE PINS	ZQW PACKAGE PINS
Data Transmit	13 - P1.1	H1 - P1.1
Data Receive	22 - P2.2	M3 - P2.2

Flash Memory

The flash memory can be programmed via the JTAG port, the bootstrap loader, or in-system by the CPU. The CPU can perform single-byte and single-word writes to the flash memory. Features of the flash memory include:

- Flash memory has n segments of main memory and four segments of information memory (A to D) of 64 bytes each. Each segment in main memory is 512 bytes in size.
- Segments 0 to n may be erased in one step, or each segment may be individually erased.
- Segments A to D can be erased individually, or as a group with segments 0 to n. Segments A to D are also called *information memory*.
- Segment A contains calibration data. After reset segment A is protected against programming and erasing. It can be unlocked but care should be taken not to erase this segment if the device-specific calibration data is required.
- Flash content integrity check with marginal read modes

Peripherals

Peripherals are connected to the CPU through data, address, and control buses and can be handled using all instructions. For complete module descriptions, see the *MSP430x2xx Family User's Guide (SLAU144)*.

DMA Controller

The DMA controller allows movement of data from one memory address to another without CPU intervention. For example, the DMA controller can be used to move data from the ADC12 conversion memory to RAM. Using the DMA controller can increase the throughput of peripheral modules. The DMA controller reduces system power consumption by allowing the CPU to remain in sleep mode without having to awaken to move data to or from a peripheral.

Oscillator and System Clock

The clock system in the MSP430F241x and MSP430F261x family of devices is supported by the basic clock module that includes support for a 32768-Hz watch crystal oscillator, an internal very low-power low-frequency oscillator, an internal digitally controlled oscillator (DCO), and a high-frequency crystal oscillator. The basic clock module is designed to meet the requirements of both low system cost and low power consumption. The internal DCO provides a fast turn-on clock source and stabilizes in less than 1 μ s. The basic clock module provides the following clock signals:

- Auxiliary clock (ACLK), sourced either from a 32768-Hz watch crystal or the internal LF oscillator.
- Main clock (MCLK), the system clock used by the CPU.
- Sub-Main clock (SMCLK), the sub-system clock used by the peripheral modules.

The DCO settings to calibrate the DCO output frequency are stored in the information memory segment A.

Calibration Data Stored in Information Memory Segment A

Calibration data is stored for the DCO and for the ADC12. It is organized in a tag-length-value (TLV) structure.

Table 10. Tags Used by the TLV Structure

NAME	ADDRESS	VALUE	DESCRIPTION
TAG_DCO_30	0x10F6	0x01	DCO frequency calibration at $V_{CC} = 3$ V and $T_A = 25^\circ\text{C}$ at calibration
TAG_ADC12_1	0x10DA	0x08	ADC12_1 calibration tag
TAG_EMPTY	-	0xFE	Identifier for empty memory areas

Table 11. Labels Used by the ADC Calibration Structure

LABEL	CONDITION AT CALIBRATION	SIZE	ADDRESS OFFSET
CAL_ADC_25T85	INCHx = 0x1010, REF2_5 = 1, $T_A = 85^\circ\text{C}$	word	0x000E
CAL_ADC_25T30	INCHx = 0x1010, REF2_5 = 1, $T_A = 30^\circ\text{C}$	word	0x000C
CAL_ADC_25VREF_FACTOR	REF2_5 = 1, $T_A = 30^\circ\text{C}$	word	0x000A
CAL_ADC_15T85	INCHx = 0x1010, REF2_5 = 0, $T_A = 85^\circ\text{C}$	word	0x0008
CAL_ADC_15T30	INCHx = 0x1010, REF2_5 = 0, $T_A = 30^\circ\text{C}$	word	0x0006
CAL_ADC_15VREF_FACTOR	REF2_5 = 0, $T_A = 30^\circ\text{C}$	word	0x0004
CAL_ADC_OFFSET	External $V_{REF} = 1.5$ V, $f_{ADC12CLK} = 5$ MHz	word	0x0002
CAL_ADC_GAIN_FACTOR	External $V_{REF} = 1.5$ V, $f_{ADC12CLK} = 5$ MHz	word	0x0000
CAL_BC1_1MHZ	-	byte	0x0007
CAL_DCO_1MHZ	-	byte	0x0006
CAL_BC1_8MHZ	-	byte	0x0005
CAL_DCO_8MHZ	-	byte	0x0004
CAL_BC1_12MHZ	-	byte	0x0003
CAL_DCO_12MHZ	-	byte	0x0002
CAL_BC1_16MHZ	-	byte	0x0001
CAL_DCO_16MHZ	-	byte	0x0000

Brownout, Supply Voltage Supervisor (SVS)

The brownout circuit is implemented to provide the proper internal reset signal to the device during power on and power off. The SVS circuitry detects if the supply voltage drops below a user selectable level and supports both supply voltage supervision (the device is automatically reset) and supply voltage monitoring (SVM) (the device is not automatically reset).

The CPU begins code execution after the brownout circuit releases the device reset. However, V_{CC} may not have ramped to $V_{CC(min)}$ at that time. The user must ensure that the default DCO settings are not changed until V_{CC} reaches $V_{CC(min)}$. If desired, the SVS circuit can be used to determine when V_{CC} reaches $V_{CC(min)}$.

Digital I/O

There are up to eight 8-bit I/O ports implemented—ports P1 through P8:

- All individual I/O bits are independently programmable.
- Any combination of input, output, and interrupt condition is possible.
- Edge-selectable interrupt input capability for all the eight bits of port P1 and port P2.
- Read and write access to port-control registers is supported by all instructions.
- Each I/O has an individually programmable pullup or pulldown resistor.
- Ports P7 and P8 can be accessed word-wise.

Watchdog Timer (WDT+)

The primary function of the watchdog timer (WDT+) module is to perform a controlled system restart after a software problem occurs. If the selected time interval expires, a system reset is generated. If the watchdog function is not needed in an application, the module can be disabled or configured as an interval timer and can generate interrupts at selected time intervals.

Hardware Multiplier

The multiplication operation is supported by a dedicated peripheral module. The module performs 16x16, 16x8, 8x16, and 8x8 bit operations. The module is capable of supporting signed and unsigned multiplication as well as signed and unsigned multiply and accumulate operations. The result of an operation can be accessed immediately after the operands have been loaded into the peripheral registers. No additional clock cycles are required.

Universal Serial Communication Interface (USCI)

The USCI modules are used for serial data communication. The USCI module supports synchronous communication protocols such as SPI (3 pin or 4 pin) or I²C, and asynchronous combination protocols such as UART, enhanced UART with automatic baudrate detection (LIN), and IrDA.

The USCI_A module provides support for SPI (3 pin or 4 pin), UART, enhanced UART, and IrDA.

The USCI_B module provides support for SPI (3 pin or 4 pin) and I²C

Timer_A3

Timer_A3 is a 16-bit timer/counter with three capture/compare registers. Timer_A3 can support multiple capture/compares, PWM outputs, and interval timing. Timer_A3 also has extensive interrupt capabilities. Interrupts may be generated from the counter on overflow conditions and from each of the capture/compare registers.

Table 12. Timer_A3 Signal Connections

INPUT PIN NUMBER		DEVICE INPUT SIGNAL	MODULE INPUT NAME	MODULE BLOCK	MODULE OUTPUT SIGNAL	OUTPUT PIN NUMBER	
ZQW	PM, PN					PM, PN	ZQW
G2 - P1.0	12 - P1.0	TACLK	TACLK	Timer	NA		
		ACLK	ACLK				
		SMCLK	SMCLK				
M2 - P2.1	21 - P2.1	TAINCLK	INCLK				
H1 - P1.1	13 - P1.1	TA0	CC10A	CCR0	TA0	13 - P1.1	H1 - P1.1
M3 - P2.2	22 - P2.2	TA0	CC10B			17 - P1.5	K1 - P1.5
		DV _{SS}	GND			27 - P2.7	L5 - P2.7
		DV _{CC}	V _{CC}				
H2 - P1.2	14 - P1.2	TA1	CC11A	CCR1	TA1	14 - P1.2	H2 - P1.2
		CAOUT (internal)	CC11B			18 - P1.6	K2 - P1.6
		DV _{SS}	GND			23 - P2.3	L3 - P2.3
		DV _{CC}	V _{CC}			ADC12 (internal)	
						DAC12_0 (internal)	
				DAC12_1 (internal)			
J1 - P1.3	15 - P1.3	TA2	CC12A	CCR2	TA2	15 - P1.3	J1 - P1.3
		ACLK (internal)	CC12B			19 - P1.7	L1 - P1.7
		DV _{SS}	GND			24 - P2.4	L4 - P2.4
		DV _{CC}	V _{CC}				

Timer_B7

Timer_B7 is a 16-bit timer/counter with seven capture/compare registers. Timer_B7 can support multiple capture/compares, PWM outputs, and interval timing. Timer_B7 also has extensive interrupt capabilities. Interrupts may be generated from the counter on overflow conditions and from each of the capture/compare registers.

Table 13. Timer_B3, Timer_B7 Signal Connections

INPUT PIN NUMBER		DEVICE INPUT SIGNAL	MODULE INPUT NAME	MODULE BLOCK	MODULE OUTPUT SIGNAL	OUTPUT PIN NUMBER	
ZQW	PM, PN					PM, PN	ZQW
K11 - P4.7	43 - P4.7	TBCLK	TBCLK	Timer	NA		
		ACLK	ACLK				
		SMCLK	SMCLK				
K11 - P4.7	43 - P4.7	TBCLK	INCLK				
M9 - P4.0	36 - P4.0	TB0	CCI0A	CCR0	TB0	36 - P4.0	M9 - P4.0
M9 - P4.0	36 - P4.0	TB0	CCI0B			ADC12 (internal)	
		DV _{SS}	GND				
		DV _{CC}	V _{CC}				
J9 - P4.1	37 - P4.1	TB1	CCI1A	CCR1	TB1	37 - P4.1	J9 - P4.1
J9 - P4.1	37 - P4.1	TB1	CCI1B			ADC12 (internal)	
		DV _{SS}	GND				
		DV _{CC}	V _{CC}				
M10 - P4.2	38 - P4.2	TB2	CCI2A	CCR2	TB2	38 - P4.2	M10 - P4.2
M10 - P4.2	38 - P4.2	TB2	CCI2B			DAC_0 (internal)	
		DV _{SS}	GND			DAC_1 (internal)	
		DV _{CC}	V _{CC}				
L10 - P4.3	39 - P4.3	TB3	CCI3A	CCR3	TB3	39 - P4.3	L10 - P4.3
L10 - P4.3	39 - P4.3	TB3	CCI3B				
		DV _{SS}	GND				
		DV _{CC}	V _{CC}				
M11 - P4.4	40 - P4.4	TB4	CCI4A	CCR4	TB4	40 - P4.4	M11 - P4.4
M11 - P4.4	40 - P4.4	TB4	CCI4B				
		DV _{SS}	GND				
		DV _{CC}	V _{CC}				
M12 - P4.5	41 - P4.5	TB5	CCI5A	CCR5	TB5	41 - P4.5	M12 - P4.5
M12 - P4.5	41 - P4.5	TB5	CCI5B				
		DV _{SS}	GND				
		DV _{CC}	V _{CC}				
L12 - P4.6	42 - P4.6	TB6	CCI6A	CCR6	TB6	42 - P4.6	L12 - P4.6
		ACLK (internal)	CCI6B				
		DV _{SS}	GND				
		DV _{CC}	V _{CC}				

Comparator_A+

The primary function of the Comparator_A+ module is to support precision slope analog-to-digital conversions, battery-voltage supervision, and monitoring of external analog signals.

ADC12

The ADC12 module supports fast 12-bit analog-to-digital conversions. The module implements a 12-bit SAR core, sample select control, reference generator, and a 16-word conversion-and-control buffer. The conversion-and-control buffer allows up to 16 independent ADC samples to be converted and stored without any CPU intervention.

DAC12

The DAC12 module is a 12-bit R-ladder voltage-output digital-to-analog converter (DAC). The DAC12 may be used in 8-bit or 12-bit mode and may be used in conjunction with the DMA controller. When multiple DAC12 modules are present, they may be grouped together for synchronous operation.

Peripheral File Map

Table 14. Peripherals File Map

MODULE	REGISTER	SHORT FORM	ADDRESS
DMA ⁽¹⁾	DMA channel 2 transfer size	DMA2SZ	0x01F2
	DMA channel 2 destination address	DMA2DA	0x01EE
	DMA channel 2 source address	DMA2SA	0x01EA
	DMA channel 2 control	DMA2CTL	0x01E8
	DMA channel 1 transfer size	DMA1SZ	0x01E6
	DMA channel 1 destination address	DMA1DA	0x01E2
	DMA channel 1 source address	DMA1SA	0x01DE
	DMA channel 1 control	DMA1CTL	0x01DC
	DMA channel 0 transfer size	DMA0SZ	0x01DA
	DMA channel 0 destination address	DMA0DA	0x01D6
	DMA channel 0 source address	DMA0SA	0x01D2
	DMA channel 0 control	DMA0CTL	0x01D0
	DMA module interrupt vector word	DMAIV	0x0126
	DMA module control 1	DMACTL1	0x0124
DMA module control 0	DMACTL0	0x0122	
DAC12 ⁽¹⁾	DAC12_1 data	DAC12_1DAT	0x01CA
	DAC12_1 control	DAC12_1CTL	0x01C2
	DAC12_0 data	DAC12_0DAT	0x01C8
	DAC12_0 control	DAC12_0CTL	0x01C0

(1) MSP430F261x devices only

Table 14. Peripherals File Map (continued)

MODULE	REGISTER	SHORT FORM	ADDRESS
ADC12	Interrupt vector word register	ADC12IV	0x01A8
	Interrupt enable register	ADC12IE	0x01A6
	Interrupt flag register	ADC12IFG	0x01A4
	Control register 1	ADC12CTL1	0x01A2
	Control register 0	ADC12CTL0	0x01A0
	Conversion memory 15	ADC12MEM15	0x015E
	Conversion memory 14	ADC12MEM14	0x015C
	Conversion memory 13	ADC12MEM13	0x015A
	Conversion memory 12	ADC12MEM12	0x0158
	Conversion memory 11	ADC12MEM11	0x0156
	Conversion memory 10	ADC12MEM10	0x0154
	Conversion memory 9	ADC12MEM9	0x0152
	Conversion memory 8	ADC12MEM8	0x0150
	Conversion memory 7	ADC12MEM7	0x014E
	Conversion memory 6	ADC12MEM6	0x014C
	Conversion memory 5	ADC12MEM5	0x014A
	Conversion memory 4	ADC12MEM4	0x0148
	Conversion memory 3	ADC12MEM3	0x0146
	Conversion memory 2	ADC12MEM2	0x0144
	Conversion memory 1	ADC12MEM1	0x0142
	Conversion memory 0	ADC12MEM0	0x0140
	ADC memory-control register15	ADC12MCTL15	0x008F
	ADC memory-control register14	ADC12MCTL14	0x008E
	ADC memory-control register13	ADC12MCTL13	0x008D
	ADC memory-control register12	ADC12MCTL12	0x008C
	ADC memory-control register11	ADC12MCTL11	0x008B
	ADC memory-control register10	ADC12MCTL10	0x008A
	ADC memory-control register9	ADC12MCTL9	0x0089
	ADC memory-control register8	ADC12MCTL8	0x0088
	ADC memory-control register7	ADC12MCTL7	0x0087
	ADC memory-control register6	ADC12MCTL6	0x0086
	ADC memory-control register5	ADC12MCTL5	0x0085
	ADC memory-control register4	ADC12MCTL4	0x0084
	ADC memory-control register3	ADC12MCTL3	0x0083
ADC memory-control register2	ADC12MCTL2	0x0082	
ADC memory-control register1	ADC12MCTL1	0x0081	
ADC memory-control register0	ADC12MCTL0	0x0080	

Table 14. Peripherals File Map (continued)

MODULE	REGISTER	SHORT FORM	ADDRESS
Timer_B7	Capture/compare register 6	TBCCR6	0x019E
	Capture/compare register 5	TBCCR5	0x019C
	Capture/compare register 4	TBCCR4	0x019A
	Capture/compare register 3	TBCCR3	0x0198
	Capture/compare register 2	TBCCR2	0x0196
	Capture/compare register 1	TBCCR1	0x0194
	Capture/compare register 0	TBCCR0	0x0192
	Timer_B register	TBR	0x0190
	Capture/compare control 6	TBCCTL6	0x018E
	Capture/compare control 5	TBCCTL5	0x018C
	Capture/compare control 4	TBCCTL4	0x018A
	Capture/compare control 3	TBCCTL3	0x0188
	Capture/compare control 2	TBCCTL2	0x0186
	Capture/compare control 1	TBCCTL1	0x0184
	Capture/compare control 0	TBCCTL0	0x0182
	Timer_B control	TBCTL	0x0180
	Timer_B interrupt vector	TBIV	0x011E
	Timer_A3	Capture/compare register 2	TACCR2
Capture/compare register 1		TACCR1	0x0174
Capture/compare register 0		TACCR0	0x0172
Timer_A register		TAR	0x0170
Reserved			0x016E
Reserved			0x016C
Reserved			0x016A
Reserved			0x0168
Capture/compare control 2		TACCTL2	0x0166
Capture/compare control 1		TACCTL1	0x0164
Capture/compare control 0		TACCTL0	0x0162
Timer_A control		TACTL	0x0160
Timer_A interrupt vector		TAIV	0x012E
Hardware Multiplier		Sum extend	SUMEXT
	Result high word	RESHI	0x013C
	Result low word	RESLO	0x013A
	Second operand	OP2	0x0138
	Multiply signed +accumulate/operand 1	MACS	0x0136
	Multiply+accumulate/operand 1	MAC	0x0134
	Multiply signed/operand 1	MPYS	0x0132
	Multiply unsigned/operand 1	MPY	0x0130
Flash	Flash control 4	FCTL4	0x01BE
	Flash control 3	FCTL3	0x012C
	Flash control 2	FCTL2	0x012A
	Flash control 1	FCTL1	0x0128
Watchdog	Watchdog Timer control	WDTCTL	0x0120

Table 14. Peripherals File Map (continued)

MODULE	REGISTER	SHORT FORM	ADDRESS
USCI_A0/B0	USCI_A0 auto baud rate control	UCA0ABCTL	0x005D
	USCI_A0 transmit buffer	UCA0TXBUF	0x0067
	USCI_A0 receive buffer	UCA0RXBUF	0x0066
	USCI_A0 status	UCA0STAT	0x0065
	USCI_A0 modulation control	UCA0MCTL	0x0064
	USCI_A0 baud rate control 1	UCA0BR1	0x0063
	USCI_A0 baud rate control 0	UCA0BR0	0x0062
	USCI_A0 control 1	UCA0CTL1	0x0061
	USCI_A0 control 0	UCA0CTL0	0x0060
	USCI_A0 IrDA receive control	UCA0IRRCTL	0x005F
	USCI_A0 IrDA transmit control	UCA0IRTCLT	0x005E
	USCI_B0 transmit buffer	UCB0TXBUF	0x006F
	USCI_B0 receive buffer	UCB0RXBUF	0x006E
	USCI_B0 status	UCB0STAT	0x006D
	USCI_B0 I2C Interrupt enable	UCB0CIE	0x006C
	USCI_B0 baud rate control 1	UCB0BR1	0x006B
	USCI_B0 baud rate control 0	UCB0BR0	0x006A
	USCI_B0 control 1	UCB0CTL1	0x0069
	USCI_B0 control 0	UCB0CTL0	0x0068
	USCI_B0 I2C slave address	UCB0SA	0x011A
USCI_B0 I2C own address	UCB0OA	0x0118	
USCI_A1/B1	USCI_A1 auto baud rate control	UCA1ABCTL	0x00CD
	USCI_A1 transmit buffer	UCA1TXBUF	0x00D7
	USCI_A1 receive buffer	UCA1RXBUF	0x00D6
	USCI_A1 status	UCA1STAT	0x00D5
	USCI_A1 modulation control	UCA1MCTL	0x00D4
	USCI_A1 baud rate control 1	UCA1BR1	0x00D3
	USCI_A1 baud rate control 0	UCA1BR0	0x00D2
	USCI_A1 control 1	UCA1CTL1	0x00D1
	USCI_A1 control 0	UCA1CTL0	0x00D0
	USCI_A1 IrDA receive control	UCA1IRRCTL	0x00CF
	USCI_A1 IrDA transmit control	UCA1IRTCLT	0x00CE
	USCI_B1 transmit buffer	UCB1TXBUF	0x00DF
	USCI_B1 receive buffer	UCB1RXBUF	0x00DE
	USCI_B1 status	UCB1STAT	0x00DD
	USCI_B1 I2C Interrupt enable	UCB1CIE	0x00DC
	USCI_B1 baud rate control 1	UCB1BR1	0x00DB
	USCI_B1 baud rate control 0	UCB1BR0	0x00DA
	USCI_B1 control 1	UCB1CTL1	0x00D9
	USCI_B1 control 0	UCB1CTL0	0x00D8
	USCI_B1 I2C slave address	UCB1SA	0x017E
USCI_B1 I2C own address	UCB1OA	0x017C	
USCI_A1/B1 interrupt enable	UC1IE	0x0006	
USCI_A1/B1 interrupt flag	UC1IFG	0x0007	
Comparator_A+	Comparator_A port disable	CAPD	0x005B
	Comparator_A control2	CACTL2	0x005A
	Comparator_A control1	CACTL1	0x0059

Table 14. Peripherals File Map (continued)

MODULE	REGISTER	SHORT FORM	ADDRESS
Basic Clock	Basic clock system control 3	BCSCTL3	0x0053
	Basic clock system control 2	BCSCTL2	0x0058
	Basic clock system control 1	BCSCTL1	0x0057
	DCO clock frequency control	DCOCTL	0x0056
Brownout, SVS	SVS control register (reset by brownout signal)	SVSCTL	0x0055
Port PA ⁽²⁾	Port PA resistor enable	PAREN	0x0014
	Port PA selection	PASEL	0x003E
	Port PA direction	PADIR	0x003C
	Port PA output	PAOUT	0x003A
	Port PA input	PAIN	0x0038
Port P8 ⁽²⁾	Port P8 resistor enable	P8REN	0x0015
	Port P8 selection	P8SEL	0x003F
	Port P8 direction	P8DIR	0x003D
	Port P8 output	P8OUT	0x003B
	Port P8 input	P8IN	0x0039
Port P7 ⁽³⁾	Port P7 resistor enable	P7REN	0x0014
	Port P7 selection	P7SEL	0x003E
	Port P7 direction	P7DIR	0x003C
	Port P7 output	P7OUT	0x003A
	Port P7 input	P7IN	0x0038
Port P6	Port P6 resistor enable	P6REN	0x0013
	Port P6 selection	P6SEL	0x0037
	Port P6 direction	P6DIR	0x0036
	Port P6 output	P6OUT	0x0035
	Port P6 input	P6IN	0x0034
Port P5	Port P5 resistor enable	P5REN	0x0012
	Port P5 selection	P5SEL	0x0033
	Port P5 direction	P5DIR	0x0032
	Port P5 output	P5OUT	0x0031
	Port P5 input	P5IN	0x0030
Port P4	Port P4 selection	P4SEL	0x001F
	Port P4 resistor enable	P4REN	0x0011
	Port P4 direction	P4DIR	0x001E
	Port P4 output	P4OUT	0x001D
	Port P4 input	P4IN	0x001C
Port P3	Port P3 resistor enable	P3REN	0x0010
	Port P3 selection	P3SEL	0x001B
	Port P3 direction	P3DIR	0x001A
	Port P3 output	P3OUT	0x0019
	Port P3 input	P3IN	0x0018

(2) 80-pin PN and 113-pin ZQW devices only

(3) 80-pin PN and 113-pin ZQW devices only

Table 14. Peripherals File Map (continued)

MODULE	REGISTER	SHORT FORM	ADDRESS
Port P2	Port P2 resistor enable	P2REN	0x002F
	Port P2 selection	P2SEL	0x002E
	Port P2 interrupt enable	P2IE	0x002D
	Port P2 interrupt-edge select	P2IES	0x002C
	Port P2 interrupt flag	P2IFG	0x002B
	Port P2 direction	P2DIR	0x002A
	Port P2 output	P2OUT	0x0029
	Port P2 input	P2IN	0x0028
Port P1	Port P1 resistor enable	P1REN	0x0027
	Port P1 selection	P1SEL	0x0026
	Port P1 interrupt enable	P1IE	0x0025
	Port P1 interrupt-edge select	P1IES	0x0024
	Port P1 interrupt flag	P1IFG	0x0023
	Port P1 direction	P1DIR	0x0022
	Port P1 output	P1OUT	0x0021
	Port P1 input	P1IN	0x0020
Special Functions	SFR interrupt flag 2	IFG2	0x0003
	SFR interrupt flag 1	IFG1	0x0002
	SFR interrupt enable 2	IE2	0x0001
	SFR interrupt enable 1	IE1	0x0000

Absolute Maximum Ratings⁽¹⁾

Voltage applied at V _{CC} to V _{SS}		-0.3 V to 4.1 V	
Voltage applied to any pin ⁽²⁾		-0.3 V to V _{CC} + 0.3 V	
Diode current at any device terminal		±2 mA	
T _{stg}	Storage temperature ⁽³⁾	Unprogrammed device	-55°C to 150°C
		Programmed device	-55°C to 150°C

- (1) Stresses beyond those listed under "absolute maximum ratings" may cause permanent damage to the device. These are stress ratings only, and functional operation of the device at these or any other conditions beyond those indicated under "recommended operating conditions" is not implied. Exposure to absolute-maximum-rated conditions for extended periods may affect device reliability.
- (2) All voltages referenced to V_{SS}. The JTAG fuse-blow voltage, V_{FB}, is allowed to exceed the absolute maximum rating. The voltage is applied to the TEST pin when blowing the JTAG fuse.
- (3) Higher temperature may be applied during board soldering according to the current JEDEC J-STD-020 specification with peak reflow temperatures not higher than classified on the device label on the shipping boxes or reels.

Recommended Operating Conditions

		MIN	MAX	UNIT
V _{CC}	Supply voltage (AV _{CC} = DV _{CC} = V _{CC} ⁽¹⁾)	During program execution		V
		1.8	3.6	
		During flash program/erase		
		2.2	3.6	
V _{SS}	Supply voltage (AV _{SS} = DV _{SS} = V _{SS})	0	0	V
T _A	Operating free-air temperature	I version		°C
		-40	85	
		T version		
		-40	105	
f _{SYSTEM}	Processor frequency (maximum MCLK frequency) ⁽²⁾⁽³⁾	V _{CC} = 1.8 V, Duty cycle = 50% ± 10%		MHz
		dc	4.15	
		V _{CC} = 2.7 V, Duty cycle = 50% ± 10%		
		V _{CC} ≥ 3.3 V, Duty cycle = 50% ± 10%		
		dc	16	

- (1) It is recommended to power AV_{CC} and DV_{CC} from the same source. A maximum difference of 0.3 V between AV_{CC} and DV_{CC} can be tolerated during power-up.
- (2) The MSP430 CPU is clocked directly with MCLK. Both the high and low phases of MCLK must not exceed the pulse duration of the specified maximum frequency.
- (3) Modules might have a different maximum input clock specification. See the specification of the respective module in this data sheet.

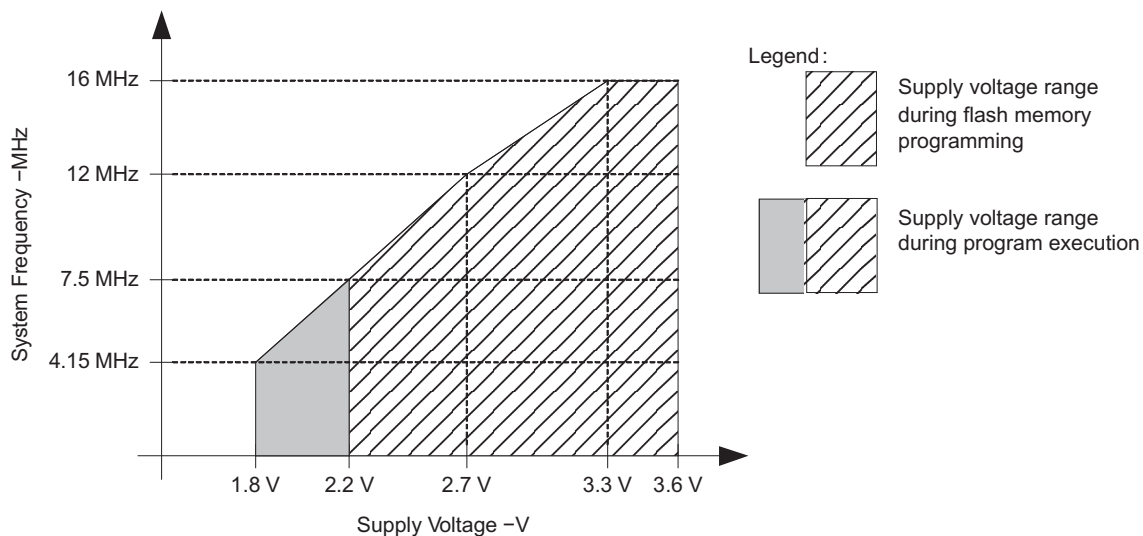

Note: Minimum processor frequency is defined by system clock. Flash program or erase operations require a minimum V_{CC} of 2.2 V.

Figure 1. Operating Area

Electrical Characteristics

Active Mode Supply Current Into V_{CC} Excluding External Current

 over recommended ranges of supply voltage and operating free-air temperature (unless otherwise noted)⁽¹⁾⁽²⁾

PARAMETER	TEST CONDITIONS	T_A	V_{CC}				UNIT
				MIN	TYP	MAX	
$I_{AM,1MHz}$ Active mode (AM) current (1 MHz)	$f_{DCO} = f_{MCLK} = f_{SMCLK} = 1\text{ MHz}$, $f_{ACLK} = 32768\text{ Hz}$, Program executes in flash, BCSCTL1 = CALBC1_1MHZ, DCOCTL = CALDCO_1MHZ, CPUOFF = 0, SCG0 = 0, SCG1 = 0, OSCOFF = 0	-40°C to 85°C	2.2 V	365	395	μA	
		105°C		375	420		
		-40°C to 85°C	3 V	515	560		
		105°C		525	595		
$I_{AM,1MHz}$ Active mode (AM) current (1 MHz)	$f_{DCO} = f_{MCLK} = f_{SMCLK} = 1\text{ MHz}$, $f_{ACLK} = 32768\text{ Hz}$, Program executes in RAM, BCSCTL1 = CALBC1_1MHZ, DCOCTL = CALDCO_1MHZ, CPUOFF = 0, SCG0 = 0, SCG1 = 0, OSCOFF = 0	-40°C to 85°C	2.2 V	330	370	μA	
		105°C		340	390		
		-40°C to 85°C	3 V	460	495		
		105°C		470	520		
$I_{AM,4kHz}$ Active mode (AM) current (4 kHz)	$f_{MCLK} = f_{SMCLK} = f_{ACLK} = 32768\text{ Hz}/8 = 4096\text{ Hz}$, $f_{DCO} = 0\text{ Hz}$, Program executes in flash, SELMx = 11, SELS = 1, DIVMx = DIVSx = DIVAx = 11, CPUOFF = 0, SCG0 = 1, SCG1 = 0, OSCOFF = 0	-40°C to 85°C	2.2 V	2.1	9	μA	
		105°C	2.2 V	15	31		
		-40°C to 85°C	3 V	3	11		
		105°C	3 V	19	32		
$I_{AM,100kHz}$ Active mode (AM) current (100 kHz)	$f_{MCLK} = f_{SMCLK} = f_{DCO(0,0)} \approx 100\text{ kHz}$, $f_{ACLK} = 0\text{ Hz}$, Program executes in flash, RSELx = 0, DCOx = 0, CPUOFF = 0, SCG0 = 0, SCG1 = 0, OSCOFF = 1	-40°C to 85°C	2.2 V	67	86	μA	
		105°C	2.2 V	80	99		
		-40°C to 85°C	3 V	84	107		
		105°C	3 V	99	128		

(1) All inputs are tied to 0 V or to V_{CC} . Outputs do not source or sink any current.

(2) The currents are characterized with a Micro Crystal CC4V-T1A SMD crystal with a load capacitance of 9 pF. The internal and external load capacitance is chosen to closely match the required 9 pF.

Typical Characteristics - Active Mode Supply Current (Into V_{CC})

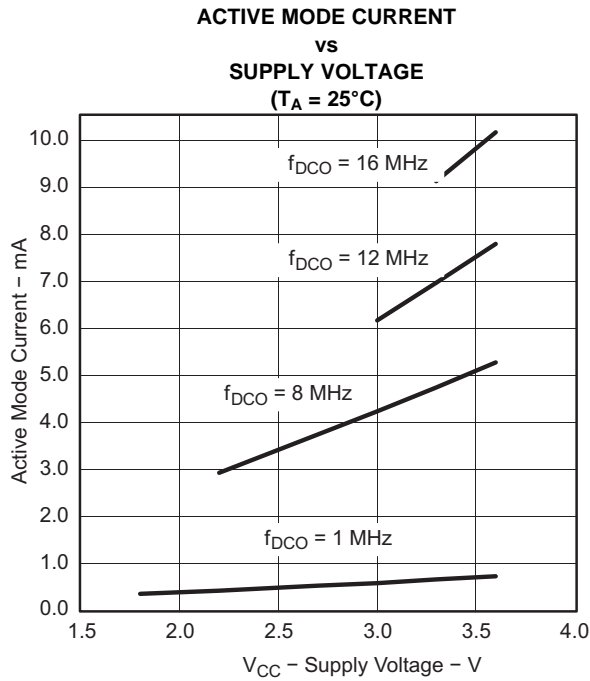

Figure 2.

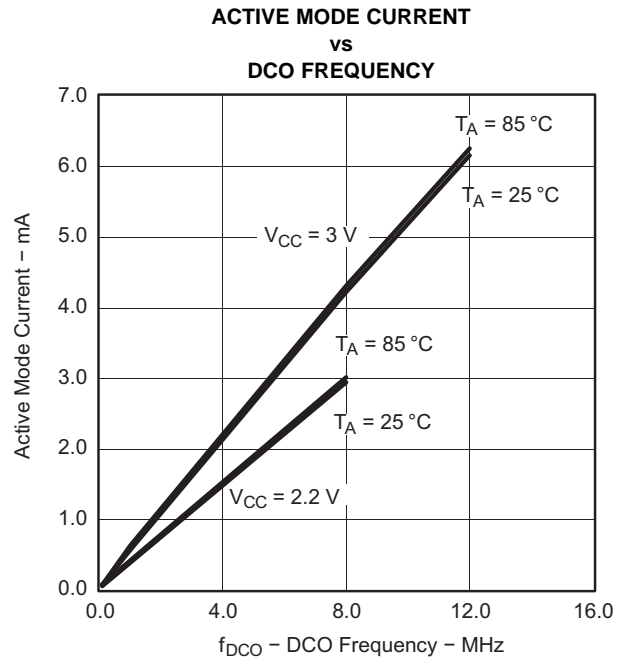

Figure 3.

Low-Power Mode Supply Currents (Into V_{CC}) Excluding External Current

 over recommended ranges of supply voltage and operating free-air temperature (unless otherwise noted)^{(1) (2)}

PARAMETER	TEST CONDITIONS	T_A	V_{CC}	MIN	TYP	MAX	UNIT
$I_{LPM0,1MHz}$	Low-power mode 0 (LPM0) current ⁽³⁾ $f_{MCLK} = 0$ MHz, $f_{SMCLK} = f_{DCO} = 1$ MHz, $f_{ACLK} = 32,768$ Hz, BCSCTL1 = CALBC1_1MHZ, DCOCTL = CALDCO_1MHZ, CPUOFF = 1, SCG0 = 0, SCG1 = 0, OSCOFF = 0	-40°C to 85°C	2.2 V	68	63	μ A	
		105°C		83	98		
		-40°C to 85°C	3 V	87	105		
		105°C		100	125		
$I_{LPM0,100kHz}$	Low-power mode 0 (LPM0) current ⁽³⁾ $f_{MCLK} = 0$ MHz, $f_{SMCLK} = f_{DCO(0, 0)} \approx 100$ kHz, $f_{ACLK} = 0$ Hz, RSELX = 0, DCOx = 0, CPUOFF = 1, SCG0 = 0, SCG1 = 0, OSCOFF = 1	-40°C to 85°C	2.2 V	37	49	μ A	
		105°C		50	62		
		-40°C to 85°C	3 V	40	55		
		105°C		57	73		
I_{LPM2}	Low-power mode 2 (LPM2) current ⁽⁴⁾ $f_{MCLK} = f_{SMCLK} = 0$ MHz, $f_{DCO} = 1$ MHz, $f_{ACLK} = 32,768$ Hz, BCSCTL1 = CALBC1_1MHZ, DCOCTL = CALDCO_1MHZ, CPUOFF = 1, SCG0 = 0, SCG1 = 1, OSCOFF = 0	-40°C to 85°C	2.2 V	23	33	μ A	
		105°C		35	46		
		-40°C to 85°C	3 V	25	36		
		105°C		40	55		
$I_{LPM3,LFXT1}$	Low-power mode 3 (LPM3) current ⁽³⁾ $f_{DCO} = f_{MCLK} = f_{SMCLK} = 0$ MHz, $f_{ACLK} = 32,768$ Hz, CPUOFF = 1, SCG0 = 1, SCG1 = 1, OSCOFF = 0	-40°C	2.2 V	0.8	1.2	μ A	
		25°C		1	1.3		
		85°C		4.6	7		
		105°C		14	24		
		-40°C	3 V	0.9	1.3		
		25°C		1.1	1.5		
		85°C		5.5	8		
		105°C		17	30		
$I_{LPM3,VLO}$	Low-power mode 3 (LPM3) current ⁽⁴⁾ $f_{DCO} = f_{MCLK} = f_{SMCLK} = 0$ MHz, f_{ACLK} from internal LF oscillator (VLO), CPUOFF = 1, SCG0 = 1, SCG1 = 1, OSCOFF = 0	-40°C	2.2 V	0.4	1	μ A	
		25°C		0.5	1		
		85°C		4.3	6.5		
		105°C		14	24		
		-40°C	3 V	0.6	1.2		
		25°C		0.6	1.2		
		85°C		5	7.5		
		105°C		16.5	29.5		
I_{LPM4}	Low-power mode 4 (LPM4) current ⁽⁵⁾ $f_{DCO} = f_{MCLK} = f_{SMCLK} = 0$ MHz, $f_{ACLK} = 0$ Hz, CPUOFF = 1, SCG0 = 1, SCG1 = 1, OSCOFF = 1	-40°C	2.2 V	0.1	0.5	μ A	
		25°C		0.1	0.5		
		85°C		4	6		
		105°C		13	23		
		-40°C	3 V	0.2	0.5		
		25°C		0.2	0.5		
		85°C		4.7	7		
		105°C		14	24		

(1) All inputs are tied to 0 V or to V_{CC} . Outputs do not source or sink any current.

(2) The currents are characterized with a Micro Crystal CC4V-T1A SMD crystal with a load capacitance of 9 pF.

(3) Current for brownout and WDT clocked by SMCLK included.

(4) Current for brownout and WDT clocked by ACLK included.

(5) Current for brownout included.

Typical Characteristics - LPM4 Current

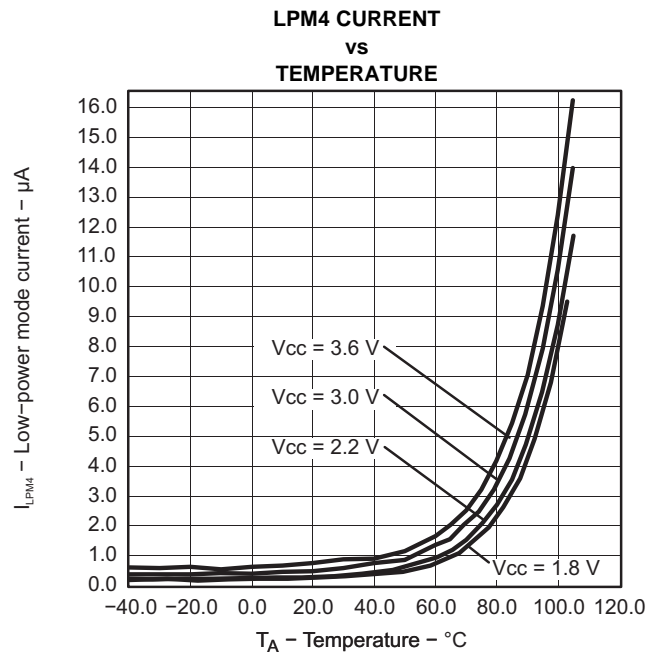

Figure 4.

Schmitt-Trigger Inputs (Ports P1 Through P8, $\overline{\text{RST}}/\text{NMI}$, JTAG, XIN, and XT2IN)⁽¹⁾

over recommended ranges of supply voltage and operating free-air temperature (unless otherwise noted)

PARAMETER		TEST CONDITIONS	V _{CC}	MIN	TYP	MAX	UNIT
V _{IT+}	Positive-going input threshold voltage			0.45 V _{CC}		0.75 V _{CC}	V
			2.2 V	1.00	1.65		
			3 V	1.35	2.25		
V _{IT-}	Negative-going input threshold voltage			0.25 V _{CC}		0.55 V _{CC}	V
			2.2 V	0.55	1.20		
			3 V	0.75	1.65		
V _{hys}	Input voltage hysteresis (V _{IT+} - V _{IT-})		2.2 V	0.2		1	V
			3 V	0.3		1	
R _{Pull}	Pullup/pulldown resistor	For pullup: V _{IN} = V _{SS} , For pulldown: V _{IN} = V _{CC}		20	35	50	kΩ
C _I	Input capacitance	V _{IN} = V _{SS} or V _{CC}			5		pF

(1) XIN and XT2IN in bypass mode only

Inputs (Ports P1 and P2)

over recommended ranges of supply voltage and operating free-air temperature (unless otherwise noted)

PARAMETER	TEST CONDITIONS	V _{CC}	MIN	MAX	UNIT
t _(int)	External interrupt timing Port P1, P2: P1.x to P2.x, External trigger pulse width to set interrupt flag ⁽¹⁾	2.2 V, 3 V	20		ns

(1) An external signal sets the interrupt flag every time the minimum interrupt pulse width t_(int) is met. It may be set even with trigger signals shorter than t_(int).

Leakage Current (Ports P1 Through P8)

over recommended ranges of supply voltage and operating free-air temperature (unless otherwise noted)

PARAMETER	TEST CONDITIONS	V _{CC}	MIN	MAX	UNIT
I _{lk(Px.y)}	High-impedance leakage current (1) (2)	2.2 V, 3 V		±50	nA

(1) The leakage current is measured with V_{SS} or V_{CC} applied to the corresponding pins, unless otherwise noted.

(2) The leakage of the digital port pins is measured individually. The port pin is selected for input and the pullup or pulldown resistor is disabled.

Standard Inputs ($\overline{\text{RST}}/\text{NMI}$)

over recommended ranges of supply voltage and operating free-air temperature (unless otherwise noted)

PARAMETER	TEST CONDITIONS	V _{CC}	MIN	MAX	UNIT
V _{IL}	Low-level input voltage	2.2 V, 3 V	V _{SS}	V _{SS} + 0.6	V
V _{IH}	High-level input voltage	2.2 V, 3 V	0.8 V _{CC}	V _{CC}	V

Outputs (Ports P1 Through P8)

over recommended ranges of supply voltage and operating free-air temperature (unless otherwise noted)

PARAMETER		TEST CONDITIONS	V _{CC}	MIN	TYP	MAX	UNIT
V _{OH}	High-level output voltage	I _(OHmax) = -1.5 mA ⁽¹⁾	2.2 V	V _{CC} - 0.25		V _{CC}	V
		I _(OHmax) = -6 mA ⁽²⁾	2.2 V	V _{CC} - 0.6		V _{CC}	
		I _(OHmax) = -1.5 mA ⁽¹⁾	3 V	V _{CC} - 0.25		V _{CC}	
		I _(OHmax) = -6 mA ⁽²⁾	3 V	V _{CC} - 0.6		V _{CC}	
V _{OL}	Low-level output voltage	I _(OLmax) = 1.5 mA ⁽¹⁾	2.2 V	V _{SS}		V _{SS} + 0.25	V
		I _(OLmax) = 6 mA ⁽²⁾	2.2 V	V _{SS}		V _{SS} + 0.6	
		I _(OLmax) = 1.5 mA ⁽¹⁾	3 V	V _{SS}		V _{SS} + 0.25	
		I _(OLmax) = 6 mA ⁽²⁾	3 V	V _{SS}		V _{SS} + 0.6	

- (1) The maximum total current, I_(OHmax) and I_(OLmax), for all outputs combined should not exceed ±12 mA to hold the maximum voltage drop specified.
- (2) The maximum total current, I_(OHmax) and I_(OLmax), for all outputs combined should not exceed ±48 mA to hold the maximum voltage drop specified.

Output Frequency (Ports P1 Through P8)

over recommended ranges of supply voltage and operating free-air temperature (unless otherwise noted)

PARAMETER		TEST CONDITIONS	V _{CC}	MIN	TYP	MAX	UNIT
f _{Px,y}	Port output frequency (with load)	P1.4/SMCLK, C _L = 20 pF, R _L = 1 kΩ ⁽¹⁾ (2)	2.2 V	dc		10	MHz
			3 V	dc		12	
f _{Port*CLK}	Clock output frequency	P2.0/ACLK/CA2, P1.4/SMCLK, C _L = 20 pF ⁽²⁾	2.2 V	dc		12	MHz
			3 V	dc		16	
t _(Xdc)	Duty cycle of output frequency	P5.6/ACLK, C _L = 20 pF, LF mode		30	50	70	%
		P5.6/ACLK, C _L = 20 pF, XT1 mode		40	50	60	
		P5.4/MCLK, C _L = 20 pF, XT1 mode		40		60	
		P5.4/MCLK, C _L = 20 pF, DCO		50% - 15 ns		50% + 15 ns	
		P1.4/SMCLK, C _L = 20 pF, XT2 mode		40		60	
		P1.4/SMCLK, C _L = 20 pF, DCO		50% - 15 ns		50% + 15 ns	

- (1) A resistive divider with two 0.5-kΩ resistors between V_{CC} and V_{SS} is used as load. The output is connected to the center tap of the divider.
- (2) The output voltage reaches at least 10% and 90% V_{CC} at the specified toggle frequency.

Typical Characteristics - Outputs

over recommended ranges of supply voltage and operating free-air temperature (unless otherwise noted)

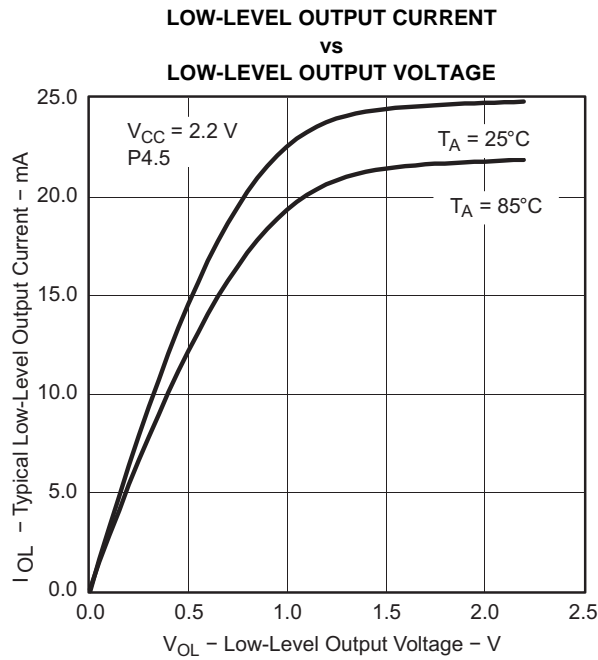

Figure 5.

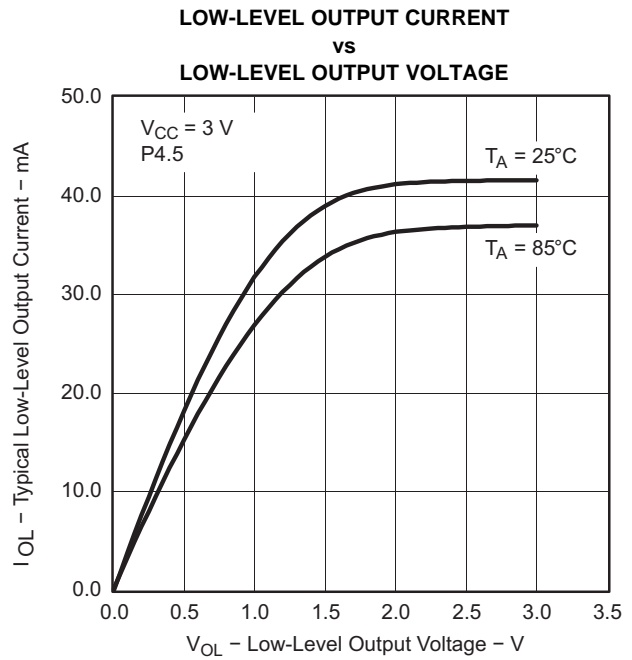

Figure 6.

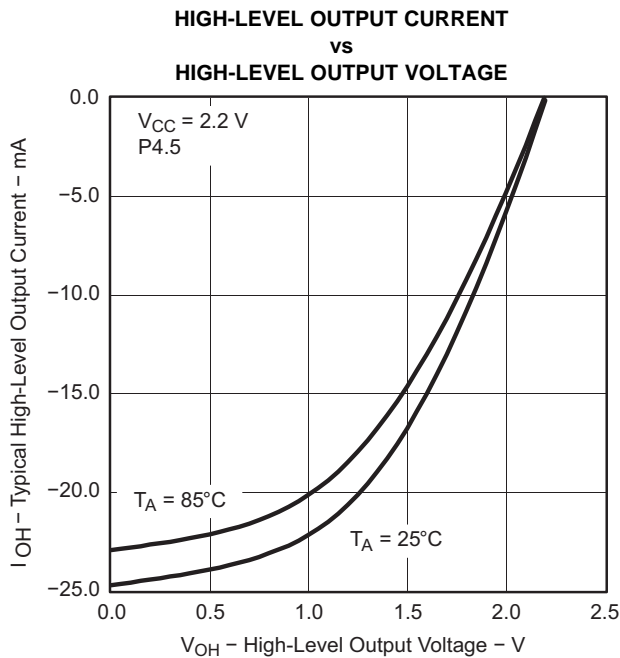

Figure 7.

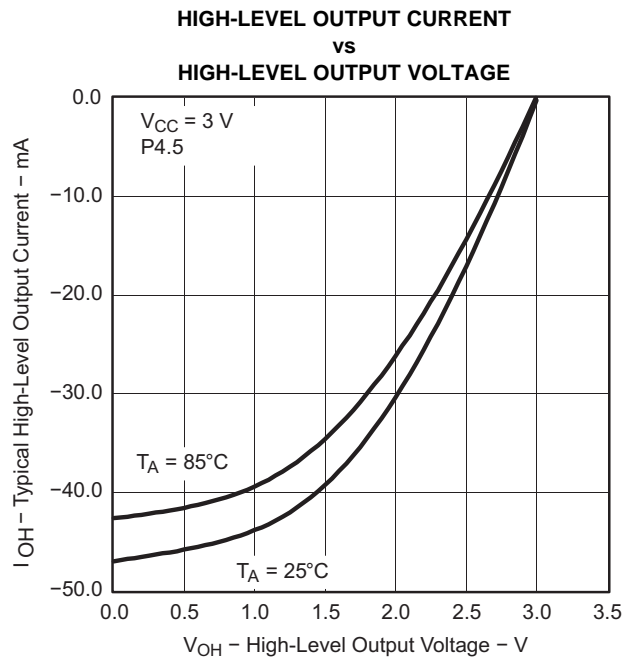

Figure 8.

POR and Brownout Reset (BOR)⁽¹⁾

over recommended ranges of supply voltage and operating free-air temperature (unless otherwise noted)

PARAMETER		TEST CONDITIONS	V _{CC}	MIN	TYP	MAX	UNIT
V _{CC(start)}	See Figure 9	dV _{CC} /dt ≤ 3 V/s			0.7 × V _(B_IT-)		V
V _(B_IT-)	See Figure 9 through Figure 11	dV _{CC} /dt ≤ 3 V/s				1.71	V
V _{hys(B_IT-)}	See Figure 9	dV _{CC} /dt ≤ 3 V/s		70	130	210	mV
t _{d(BOR)}	See Figure 9					2000	μs
t _(reset)	Pulse length needed at $\overline{\text{RST}}/\text{NMI}$ pin to accepted reset internally		2.2 V, 3 V	2			μs

(1) The current consumption of the brownout module is already included in the I_{CC} current consumption data. The voltage level V_(B_IT-) + V_{hys(B_IT-)} is ≤ 1.8 V.

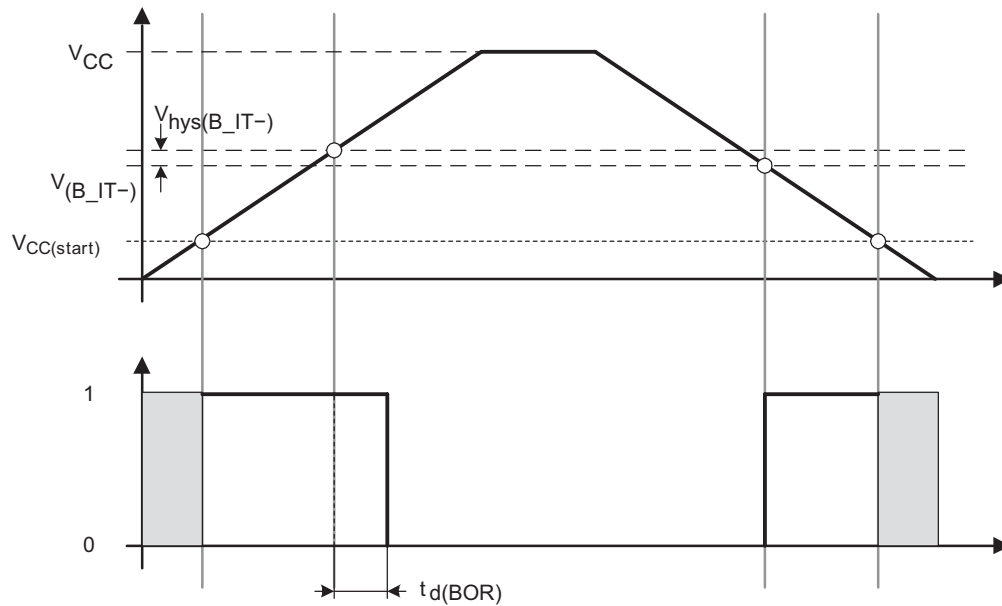

Figure 9. POR and BOR vs Supply Voltage

Typical Characteristics - POR and BOR

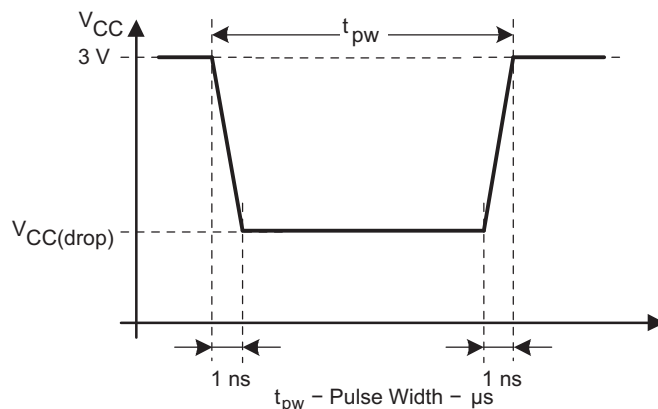
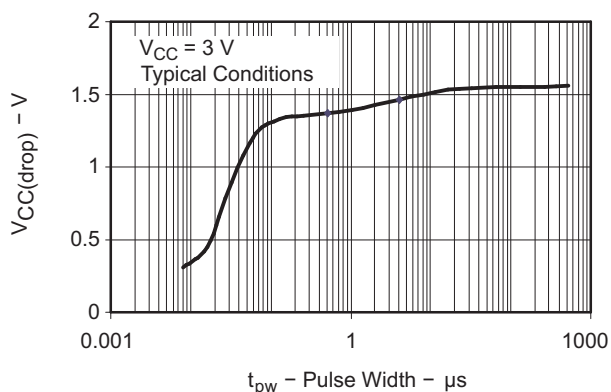

Figure 10. $V_{CC(drop)}$ Level With a Square Voltage Drop to Generate a POR for BOR Signal

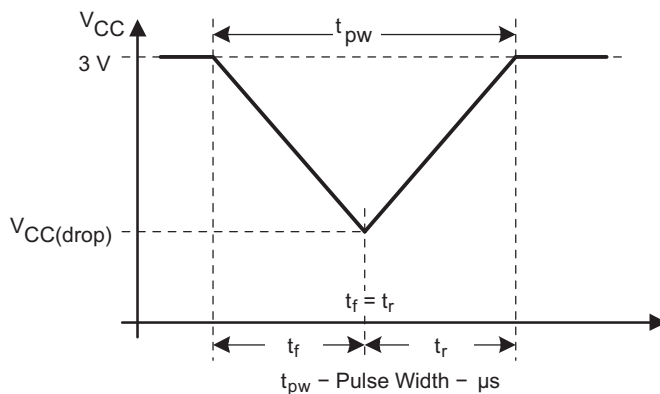
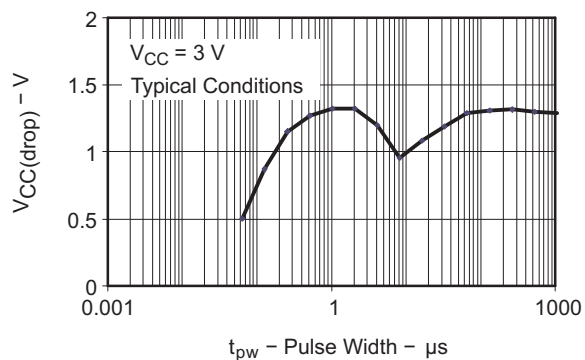

Figure 11. $V_{CC(drop)}$ Level With a Triangle Voltage Drop to Generate a POR or BOR Signal

Supply Voltage Supervisor (SVS), Supply Voltage Monitor (SVM)

over recommended operating free-air temperature range (unless otherwise noted)

PARAMETER	TEST CONDITIONS	MIN	TYP	MAX	UNIT	
$t_{(SVSR)}$	$dV_{CC}/dt > 30 \text{ V/ms}$ (see Figure 12)	5		150	μs	
	$dV_{CC}/dt \leq 30 \text{ V/ms}$			2000		
$t_{d(SV\text{Son})}$	SVSon, switch from VLD = 0 to VLD \neq 0, $V_{CC} = 3 \text{ V}$		150	300	μs	
t_{settle}	VLD \neq 0 ⁽¹⁾			12	μs	
$V_{(SV\text{Sstart})}$	VLD \neq 0, $V_{CC}/dt \leq 3 \text{ V/s}$ (see Figure 12)		1.55	1.7	V	
$V_{\text{hys}(SV\text{S_IT-})}$	$V_{CC}/dt \leq 3 \text{ V/s}$ (see Figure 12)	VLD = 1	70	120	155	mV
		VLD = 2 to 14	$0.004 \times V_{(SV\text{S_IT-})}$		$0.016 \times V_{(SV\text{S_IT-})}$	V
	$V_{CC}/dt \leq 3 \text{ V/s}$ (see Figure 12), external voltage applied on A7	VLD = 15	4.4		20	mV
$V_{(SV\text{S_IT-})}$	$V_{CC}/dt \leq 3 \text{ V/s}$ (see Figure 12 and Figure 13)	VLD = 1	1.8	1.9	2.05	V
		VLD = 2	1.94	2.1	2.25	
		VLD = 3	2.05	2.2	2.37	
		VLD = 4	2.14	2.3	2.48	
		VLD = 5	2.24	2.4	2.60	
		VLD = 6	2.33	2.5	2.71	
		VLD = 7	2.46	2.65	2.86	
		VLD = 8	2.58	2.8	3	
		VLD = 9	2.69	2.9	3.13	
		VLD = 10	2.83	3.05	3.29	
		VLD = 11	2.94	3.2	3.42	
		VLD = 12	3.11	3.35	3.61 ⁽²⁾	
		VLD = 13	3.24	3.5	3.76 ⁽²⁾	
		VLD = 14	3.43	3.7 ⁽²⁾	3.99 ⁽²⁾	
		$V_{CC}/dt \leq 3 \text{ V/s}$ (see Figure 12 and Figure 13), external voltage applied on A7	VLD = 15	1.1	1.2	
$I_{CC(SVS)}$ ⁽³⁾	VLD \neq 0, $V_{CC} = 2.2 \text{ V}, 3 \text{ V}$		10	15	μA	

- (1) t_{settle} is the settling time that the comparator output needs to have a stable level after VLD is switched from VLD \neq 0 to a different VLD value somewhere between 2 and 15. The overdrive is assumed to be $>50 \text{ mV}$.
- (2) The recommended operating voltage range is limited to 3.6 V.
- (3) The current consumption of the SVS module is not included in the I_{CC} current consumption data.

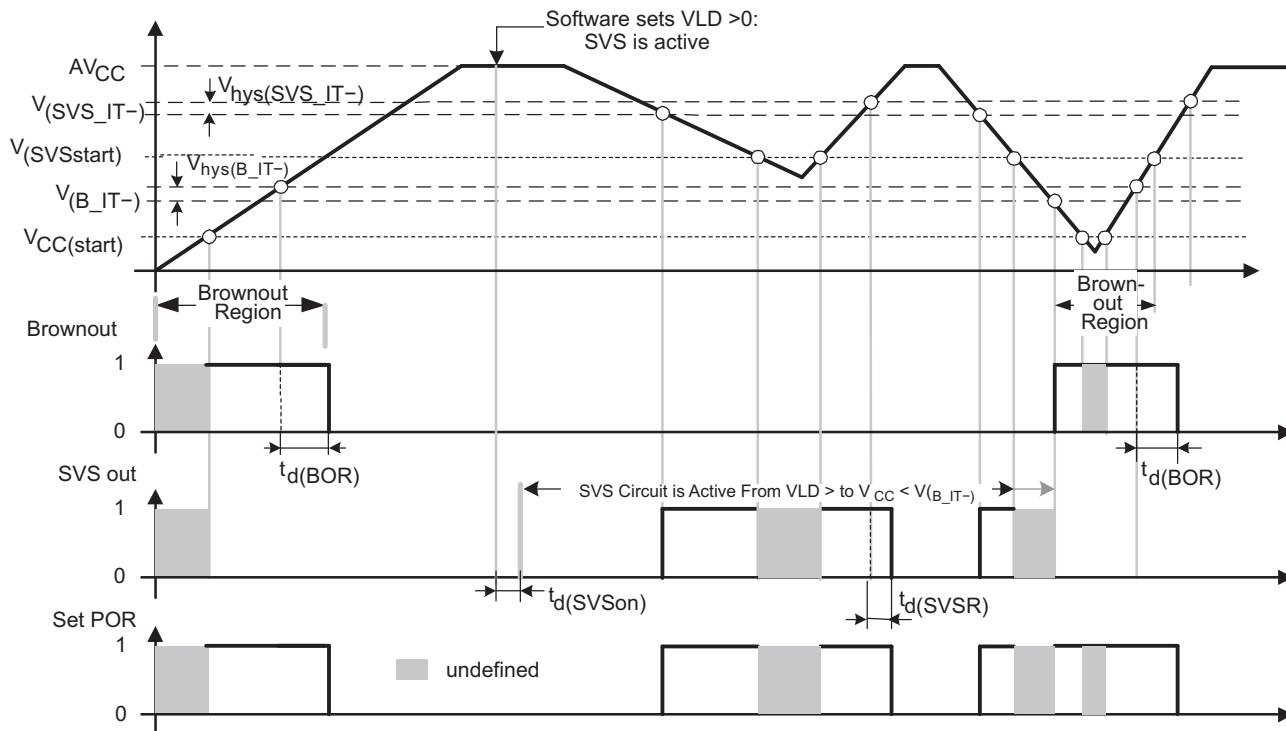

Figure 12. SVS Reset (SVSR) vs Supply Voltage

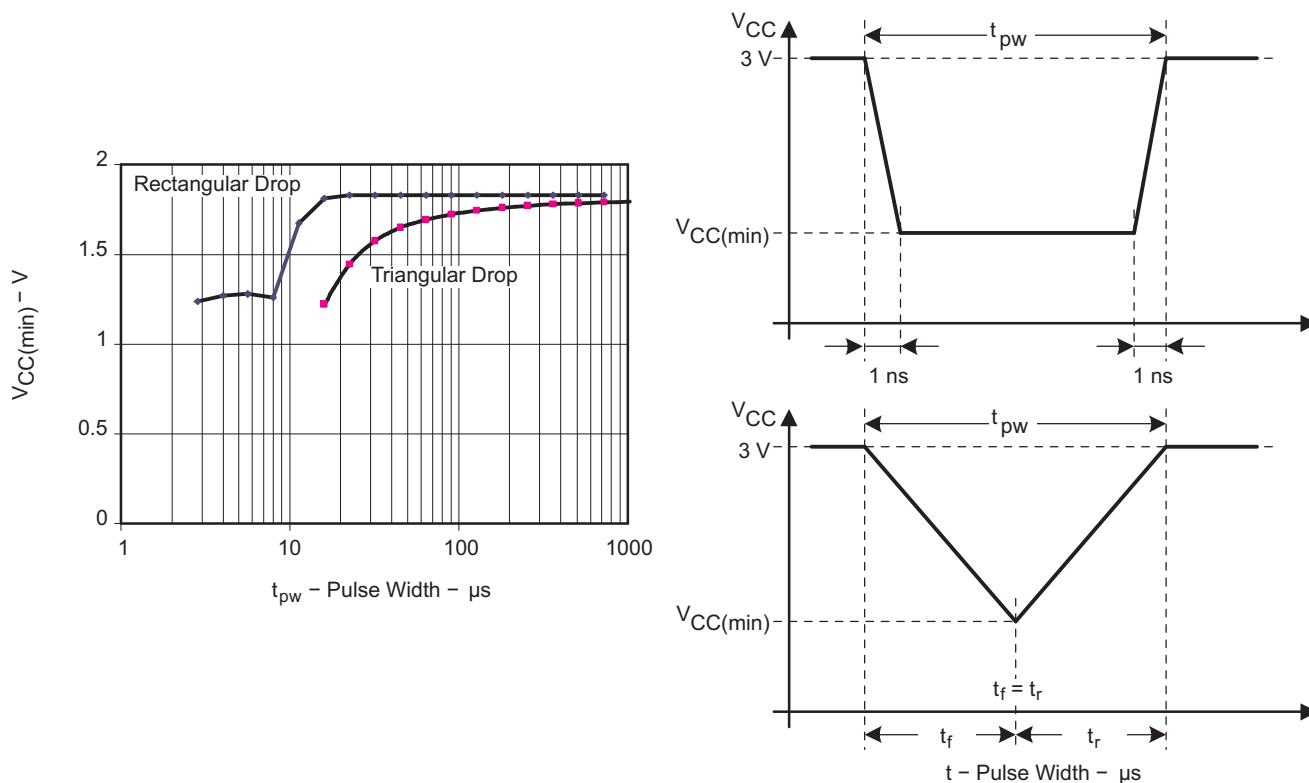

Figure 13. $V_{CC(min)}$: Square Voltage Drop and Triangle Voltage Drop to Generate an SVS Signal (VLD = 1)

Main DCO Characteristics

- All ranges selected by RSELx overlap with RSELx + 1: RSELx = 0 overlaps RSELx = 1, ... RSELx = 14 overlaps RSELx = 15.
- DCO control bits DCOx have a step size as defined by parameter S_{DCO}.
- Modulation control bits MODx select how often f_{DCO(RSEL,DCO+1)} is used within the period of 32 DCOCLK cycles. The frequency f_{DCO(RSEL,DCO)} is used for the remaining cycles. The frequency is an average equal to:

$$f_{\text{average}} = \frac{32 \times f_{\text{DCO(RSEL,DCO)}} \times f_{\text{DCO(RSEL,DCO+1)}}}{\text{MOD} \times f_{\text{DCO(RSEL,DCO)}} + (32 - \text{MOD}) \times f_{\text{DCO(RSEL,DCO+1)}}}$$

DCO Frequency

over recommended ranges of supply voltage and operating free-air temperature (unless otherwise noted)

PARAMETER		TEST CONDITIONS	V _{CC}	MIN	TYP	MAX	UNIT
V _{CC}	Supply voltage	RSELx < 14		1.8		3.6	V
		RSELx = 14		2.2		3.6	
		RSELx = 15		3.0		3.6	
f _{DCO(0,0)}	DCO frequency (0, 0)	RSELx = 0, DCOx = 0, MODx = 0	2.2 V, 3 V	0.06		0.14	MHz
f _{DCO(0,3)}	DCO frequency (0, 3)	RSELx = 0, DCOx = 3, MODx = 0	2.2 V, 3 V	0.07		0.17	MHz
f _{DCO(1,3)}	DCO frequency (1, 3)	RSELx = 1, DCOx = 3, MODx = 0	2.2 V, 3 V	0.10		0.20	MHz
f _{DCO(2,3)}	DCO frequency (2, 3)	RSELx = 2, DCOx = 3, MODx = 0	2.2 V, 3 V	0.14		0.28	MHz
f _{DCO(3,3)}	DCO frequency (3, 3)	RSELx = 3, DCOx = 3, MODx = 0	2.2 V, 3 V	0.20		0.40	MHz
f _{DCO(4,3)}	DCO frequency (4, 3)	RSELx = 4, DCOx = 3, MODx = 0	2.2 V, 3 V	0.28		0.54	MHz
f _{DCO(5,3)}	DCO frequency (5, 3)	RSELx = 5, DCOx = 3, MODx = 0	2.2 V, 3 V	0.39		0.77	MHz
f _{DCO(6,3)}	DCO frequency (6, 3)	RSELx = 6, DCOx = 3, MODx = 0	2.2 V, 3 V	0.54		1.06	MHz
f _{DCO(7,3)}	DCO frequency (7, 3)	RSELx = 7, DCOx = 3, MODx = 0	2.2 V, 3 V	0.80		1.50	MHz
f _{DCO(8,3)}	DCO frequency (8, 3)	RSELx = 8, DCOx = 3, MODx = 0	2.2 V, 3 V	1.10		2.10	MHz
f _{DCO(9,3)}	DCO frequency (9, 3)	RSELx = 9, DCOx = 3, MODx = 0	2.2 V, 3 V	1.60		3.00	MHz
f _{DCO(10,3)}	DCO frequency (10, 3)	RSELx = 10, DCOx = 3, MODx = 0	2.2 V, 3 V	2.50		4.30	MHz
f _{DCO(11,3)}	DCO frequency (11, 3)	RSELx = 11, DCOx = 3, MODx = 0	2.2 V, 3 V	3.00		5.50	MHz
f _{DCO(12,3)}	DCO frequency (12, 3)	RSELx = 12, DCOx = 3, MODx = 0	2.2 V, 3 V	4.30		7.30	MHz
f _{DCO(13,3)}	DCO frequency (13, 3)	RSELx = 13, DCOx = 3, MODx = 0	2.2 V, 3 V	6.00		9.60	MHz
f _{DCO(14,3)}	DCO frequency (14, 3)	RSELx = 14, DCOx = 3, MODx = 0	2.2 V, 3 V	8.60		13.9	MHz
f _{DCO(15,3)}	DCO frequency (15, 3)	RSELx = 15, DCOx = 3, MODx = 0	3 V	12.0		18.5	MHz
f _{DCO(15,7)}	DCO frequency (15, 7)	RSELx = 15, DCOx = 7, MODx = 0	3 V	16.0		26.0	MHz
S _{RSEL}	Frequency step between range RSEL and RSEL+1	S _{RSEL} = f _{DCO(RSEL+1,DCO)} /f _{DCO(RSEL,DCO)}	2.2 V, 3 V			1.55	ratio
S _{DCO}	Frequency step between tap DCO and DCO+1	S _{DCO} = f _{DCO(RSEL,DCO+1)} /f _{DCO(RSEL,DCO)}	2.2 V, 3 V	1.05	1.08	1.12	ratio
	Duty cycle	Measured at P1.4/SMCLK	2.2 V, 3 V	40	50	60	%

Calibrated DCO Frequencies - Tolerance at Calibration

over recommended ranges of supply voltage and operating free-air temperature (unless otherwise noted)

PARAMETER	TEST CONDITIONS	T _A	V _{CC}	MIN	TYP	MAX	UNIT
Frequency tolerance at calibration		25°C	3 V	-1	±0.2	+1	%
f _{CAL(1MHz)} 1-MHz calibration value	BCSCTL1 = CALBC1_1MHZ, DCOCTL = CALDCO_1MHZ, Gating time: 5 ms	25°C	3 V	0.990	1	1.010	MHz
f _{CAL(8MHz)} 8-MHz calibration value	BCSCTL1 = CALBC1_8MHZ, DCOCTL = CALDCO_8MHZ, Gating time: 5 ms	25°C	3 V	7.920	8	8.080	MHz
f _{CAL(12MHz)} 12-MHz calibration value	BCSCTL1 = CALBC1_12MHZ, DCOCTL = CALDCO_12MHZ, Gating time: 5 ms	25°C	3 V	11.88	12	12.12	MHz
f _{CAL(16MHz)} 16-MHz calibration value	BCSCTL1 = CALBC1_16MHZ, DCOCTL = CALDCO_16MHZ, Gating time: 2 ms	25°C	3 V	15.84	16	16.16	MHz

Calibrated DCO Frequencies - Tolerance Over Temperature 0°C to 85°C

over recommended ranges of supply voltage and operating free-air temperature (unless otherwise noted)

PARAMETER	TEST CONDITIONS	T _A	V _{CC}	MIN	TYP	MAX	UNIT
1-MHz tolerance over temperature		0°C to 85°C	3 V	-2.5	±0.5	+2.5	%
8-MHz tolerance over temperature		0°C to 85°C	3 V	-2.5	±1.0	+2.5	%
12-MHz tolerance over temperature		0°C to 85°C	3 V	-2.5	±1.0	+2.5	%
16-MHz tolerance over temperature		0°C to 85°C	3 V	-3	±2.0	+3	%
f _{CAL(1MHz)} 1-MHz calibration value	BCSCTL1 = CALBC1_1MHZ, DCOCTL = CALDCO_1MHZ, Gating time: 5 ms	0°C to 85°C	2.2 V	0.970	1	1.030	MHz
			3 V	0.975	1	1.025	
			3.6 V	0.970	1	1.030	
f _{CAL(8MHz)} 8-MHz calibration value	BCSCTL1 = CALBC1_8MHZ, DCOCTL = CALDCO_8MHZ, Gating time: 5 ms	0°C to 85°C	2.2 V	7.760	8	8.40	MHz
			3 V	7.800	8	8.20	
			3.6 V	7.600	8	8.24	
f _{CAL(12MHz)} 12-MHz calibration value	BCSCTL1 = CALBC1_12MHZ, DCOCTL = CALDCO_12MHZ, Gating time: 5 ms	0°C to 85°C	2.2 V	11.64	12	12.36	MHz
			3 V	11.64	12	12.36	
			3.6 V	11.64	12	12.36	
f _{CAL(16MHz)} 16-MHz calibration value	BCSCTL1 = CALBC1_16MHZ, DCOCTL = CALDCO_16MHZ, Gating time: 2 ms	0°C to 85°C	3 V	15.52	16	16.48	MHz
			3.6 V	15.00	16	16.48	

Calibrated DCO Frequencies - Tolerance Over Supply Voltage V_{CC}

over recommended ranges of supply voltage and operating free-air temperature (unless otherwise noted)

PARAMETER	TEST CONDITIONS	T_A	V_{CC}	MIN	TYP	MAX	UNIT
1-MHz tolerance over V_{CC}		25°C	1.8 V to 3.6 V	-3	±2	+3	%
8-MHz tolerance over V_{CC}		25°C	1.8 V to 3.6 V	-3	±2	+3	%
12-MHz tolerance over V_{CC}		25°C	2.2 V to 3.6 V	-3	±2	+3	%
16-MHz tolerance over V_{CC}		25°C	3 V to 3.6 V	-6	±2	+3	%
$f_{CAL(1MHz)}$ 1-MHz calibration value	BCSCTL1 = CALBC1_1MHZ, DCOCTL = CALDCO_1MHZ, Gating time: 5 ms	25°C	1.8 V to 3.6 V	0.97	1	1.03	MHz
$f_{CAL(8MHz)}$ 8-MHz calibration value	BCSCTL1 = CALBC1_8MHZ, DCOCTL = CALDCO_8MHZ, Gating time: 5 ms	25°C	1.8 V to 3.6 V	7.76	8	8.24	MHz
$f_{CAL(12MHz)}$ 12-MHz calibration value	BCSCTL1 = CALBC1_12MHZ, DCOCTL = CALDCO_12MHZ, Gating time: 5 ms	25°C	2.2 V to 3.6 V	11.64	12	12.36	MHz
$f_{CAL(16MHz)}$ 16-MHz calibration value	BCSCTL1 = CALBC1_16MHZ, DCOCTL = CALDCO_16MHZ, Gating time: 2 ms	25°C	3 V to 3.6 V	15	16	16.48	MHz

Calibrated DCO Frequencies - Overall Tolerance

over recommended ranges of supply voltage and operating free-air temperature (unless otherwise noted)

PARAMETER	TEST CONDITIONS	T_A	V_{CC}	MIN	TYP	MAX	UNIT
1-MHz tolerance overall		-40°C to 105°C	1.8 V to 3.6 V	-5	±2	+5	%
8-MHz tolerance overall		-40°C to 105°C	1.8 V to 3.6 V	-5	±2	+5	%
12-MHz tolerance overall		-40°C to 105°C	2.2 V to 3.6 V	-5	±2	+5	%
16-MHz tolerance overall		-40°C to 105°C	3 V to 3.6 V	-6	±3	+6	%
$f_{CAL(1MHz)}$ 1-MHz calibration value	BCSCTL1 = CALBC1_1MHZ, DCOCTL = CALDCO_1MHZ, Gating time: 5 ms	-40°C to 105°C	1.8 V to 3.6 V	0.95	1	1.05	MHz
$f_{CAL(8MHz)}$ 8-MHz calibration value	BCSCTL1 = CALBC1_8MHZ, DCOCTL = CALDCO_8MHZ, Gating time: 5 ms	-40°C to 105°C	1.8 V to 3.6 V	7.6	8	8.4	MHz
$f_{CAL(12MHz)}$ 12-MHz calibration value	BCSCTL1 = CALBC1_12MHZ, DCOCTL = CALDCO_12MHZ, Gating time: 5 ms	-40°C to 105°C	2.2 V to 3.6 V	11.4	12	12.6	MHz
$f_{CAL(16MHz)}$ 16-MHz calibration value	BCSCTL1 = CALBC1_16MHZ, DCOCTL = CALDCO_16MHZ, Gating time: 2 ms	-40°C to 105°C	3 V to 3.6 V	15	16	17	MHz

Typical Characteristics - Calibrated DCO Frequency

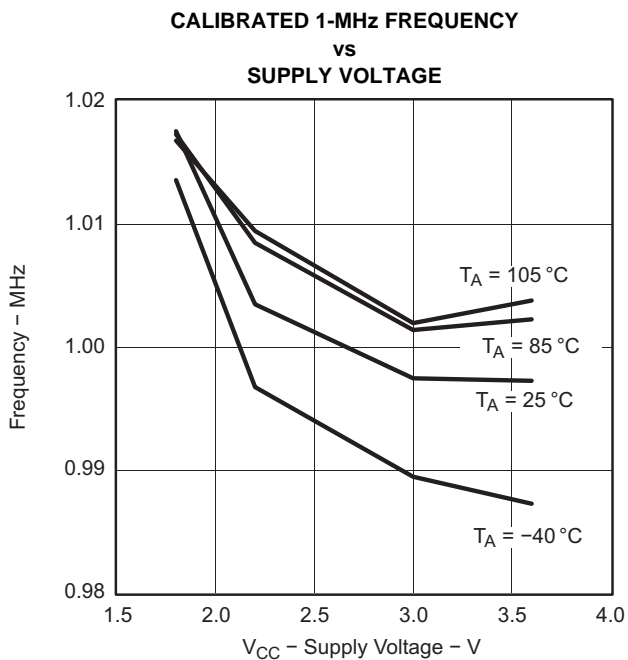

Figure 14.

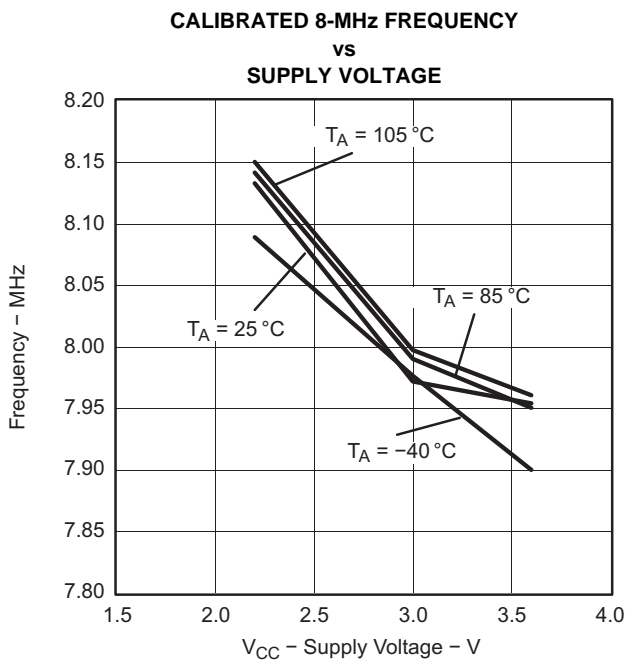

Figure 15.

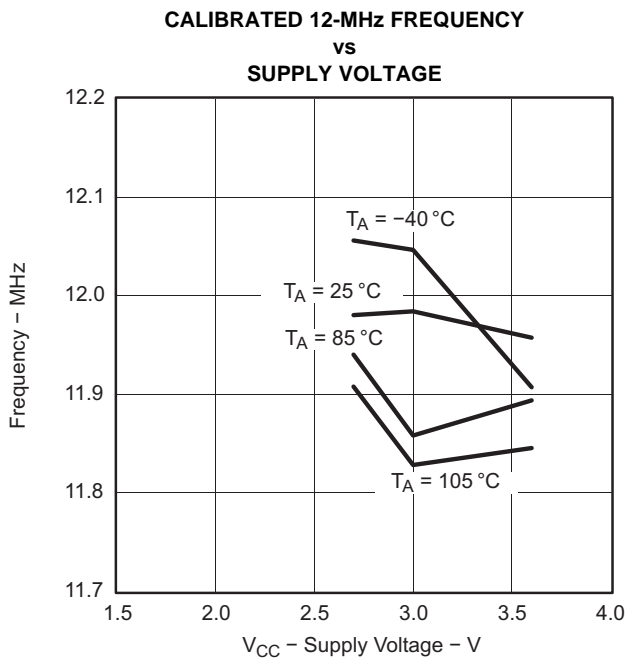

Figure 16.

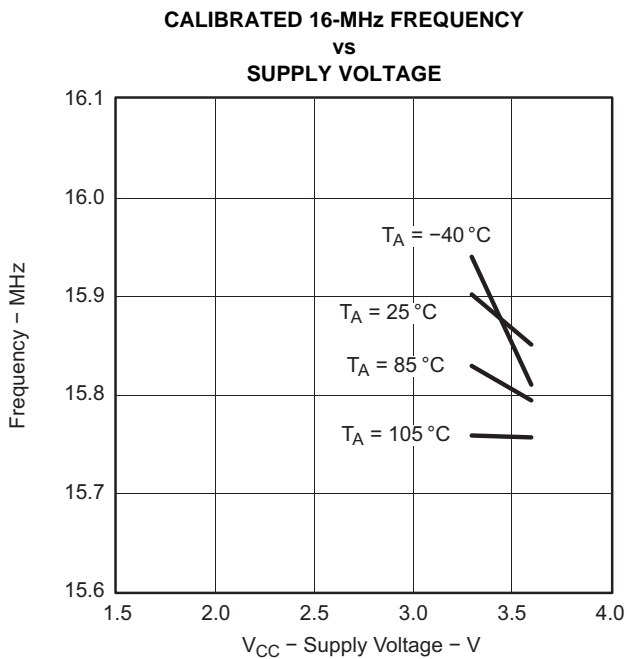

Figure 17.

Wake-Up From Lower-Power Modes (LPM3, LPM4)

over recommended ranges of supply voltage and operating free-air temperature (unless otherwise noted)

PARAMETER	TEST CONDITIONS	V _{CC}	MIN	TYP	MAX	UNIT
t _{DCO,LPM3/4} DCO clock wake-up time from LPM3 or LPM4 ⁽¹⁾	BCSCTL1 = CALBC1_1MHZ, DCOCTL = CALDCO_1MHZ	2.2 V, 3 V			2	μs
	BCSCTL1 = CALBC1_8MHZ, DCOCTL = CALDCO_8MHZ			1.5		
	BCSCTL1 = CALBC1_12MHZ, DCOCTL = CALDCO_12MHZ			1		
	BCSCTL1 = CALBC1_16MHZ, DCOCTL = CALDCO_16MHZ	3 V		1		
t _{CPU,LPM3/4} CPU wake-up time from LPM3 or LPM4 ⁽²⁾				1 / f _{MCLK} + t _{clock,LPM3/4}		

- (1) The DCO clock wake-up time is measured from the edge of an external wake-up signal (for example, port interrupt) to the first clock edge observable externally on a clock pin (MCLK or SMCLK).
- (2) Parameter applicable only if DCOCLK is used for MCLK.

Typical Characteristics - DCO Clock Wake-Up Time From LPM3 or LPM4

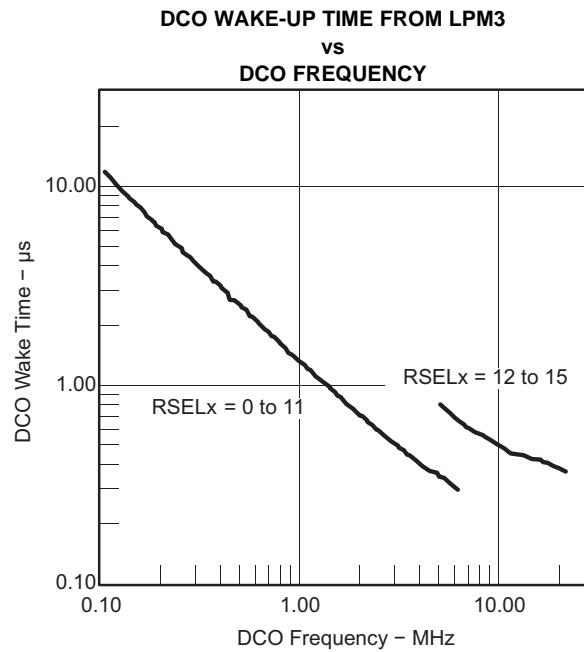

Figure 18.

DCO With External Resistor $R_{OSC}^{(1)}$

over recommended ranges of supply voltage and operating free-air temperature (unless otherwise noted)

PARAMETER		TEST CONDITIONS	V_{CC}	TYP	UNIT
$f_{DCO,ROSC}$	DCO output frequency with R_{OSC}	DCOR = 1, RSELx = 4, DCOx = 3, MODx = 0, $T_A = 25^\circ\text{C}$	2.2 V	1.8	MHz
			3 V	1.95	
D_T	Temperature drift	DCOR = 1, RSELx = 4, DCOx = 3, MODx = 0	2.2 V, 3 V	± 0.1	$\% / ^\circ\text{C}$
D_V	Drift with V_{CC}	DCOR = 1, RSELx = 4, DCOx = 3, MODx = 0	2.2 V, 3 V	10	$\% / \text{V}$

(1) $R_{OSC} = 100 \text{ k}\Omega$. Metal film resistor, type 0257, 0.6 W with 1% tolerance and $T_K = \pm 50 \text{ ppm}/^\circ\text{C}$.

Typical Characteristics - DCO With External Resistor R_{OSC}

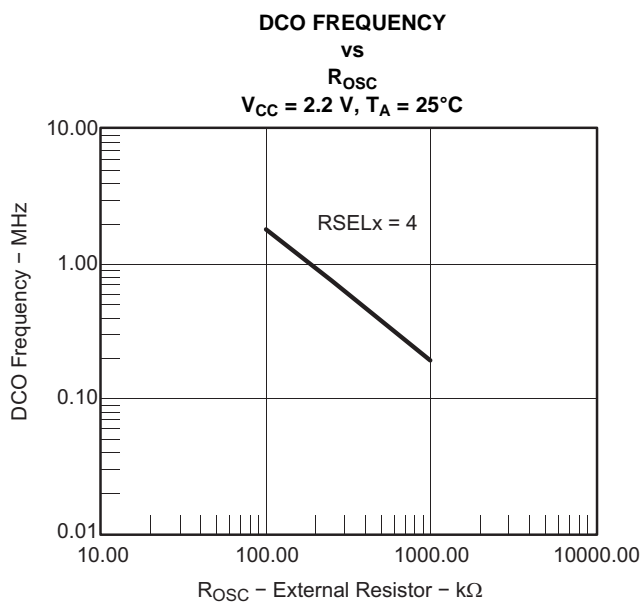

Figure 19.

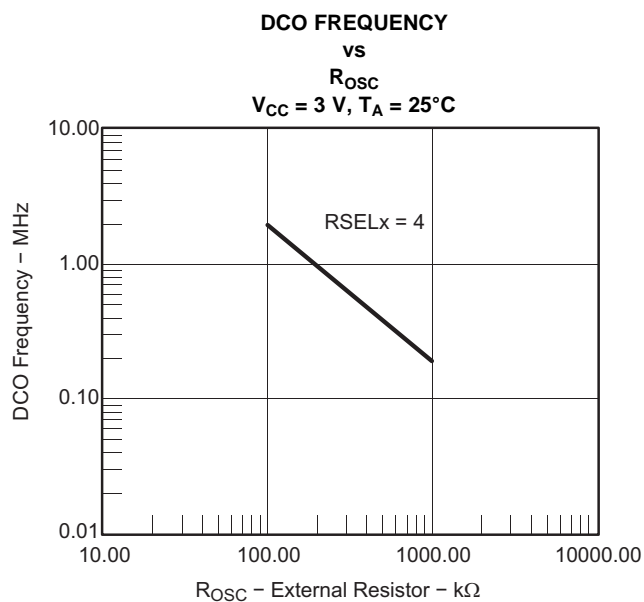

Figure 20.

Typical Characteristics - DCO With External Resistor R_{OSC} (continued)

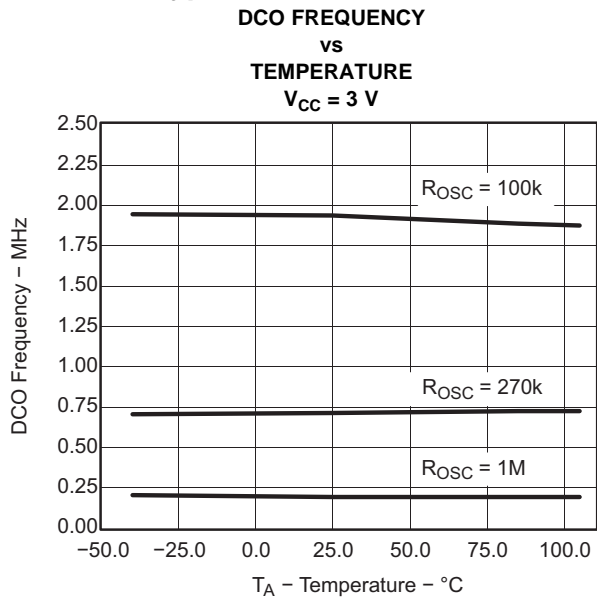

Figure 21.

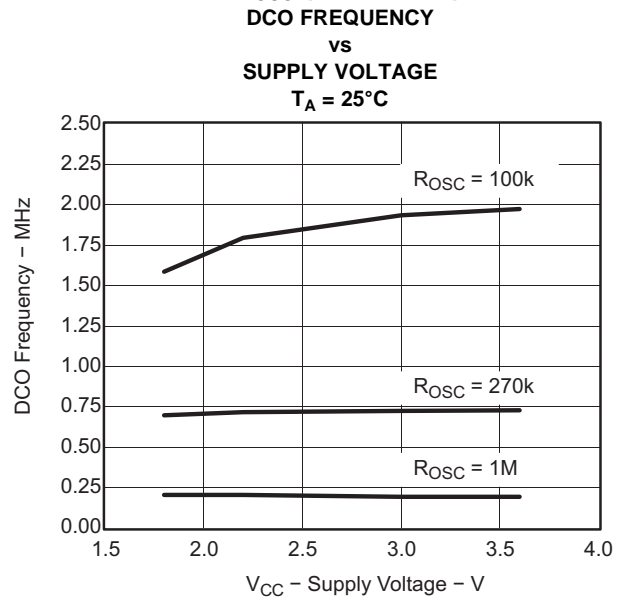

Figure 22.

Crystal Oscillator LFXT1, Low-Frequency Mode⁽¹⁾

over recommended ranges of supply voltage and operating free-air temperature (unless otherwise noted)

PARAMETER		TEST CONDITIONS	V _{CC}	MIN	TYP	MAX	UNIT
f _{LFXT1,LF}	LFXT1 oscillator crystal frequency, LF mode 0, 1	XTS = 0, LFXT1Sx = 0 or 1	1.8 V to 3.6 V		32768		Hz
f _{LFXT1,LF,logic}	LFXT1 oscillator logic level square wave input frequency, LF mode	XTS = 0, LFXT1Sx = 3, XCAPx = 0	1.8 V to 3.6 V	10000	32768	50000	Hz
O _{A,LF}	Oscillation allowance for LF crystals	XTS = 0, LFXT1Sx = 0, f _{LFXT1,LF} = 32768 Hz, C _{L,eff} = 6 pF			500		kΩ
		XTS = 0, LFXT1Sx = 0, f _{LFXT1,LF} = 32768 Hz, C _{L,eff} = 12 pF			200		
C _{L,eff}	Integrated effective load capacitance, LF mode ⁽²⁾	XTS = 0, XCAPx = 0			1		pF
		XTS = 0, XCAPx = 1			5.5		
		XTS = 0, XCAPx = 2			8.5		
		XTS = 0, XCAPx = 3			11		
	Duty cycle, LF mode	XTS = 0, Measured at P2.0/ACLK, f _{LFXT1,LF} = 32768 Hz	2.2 V, 3 V	30	50	70	%
f _{Fault,LF}	Oscillator fault frequency, LF mode ⁽³⁾	XTS = 0, LFXT1Sx = 3, XCAPx = 0 ⁽⁴⁾	2.2 V, 3 V	10		10000	Hz

- (1) To improve EMI on the XT1 oscillator, the following guidelines should be observed.
 - (a) Keep the trace between the device and the crystal as short as possible.
 - (b) Design a good ground plane around the oscillator pins.
 - (c) Prevent crosstalk from other clock or data lines into oscillator pins XIN and XOUT.
 - (d) Avoid running PCB traces underneath or adjacent to the XIN and XOUT pins.
 - (e) Use assembly materials and praxis to avoid any parasitic load on the oscillator XIN and XOUT pins.
 - (f) If conformal coating is used, ensure that it does not induce capacitive or resistive leakage between the oscillator pins.
 - (g) Do not route the XOUT line to the JTAG header to support the serial programming adapter as shown in other documentation. This signal is no longer required for the serial programming adapter.
- (2) Includes parasitic bond and package capacitance (approximately 2 pF per pin).
Because the PCB adds additional capacitance, it is recommended to verify the correct load by measuring the ACLK frequency. For a correct setup, the effective load capacitance should always match the specification of the crystal that is used.
- (3) Frequencies below the MIN specification set the fault flag. Frequencies above the MAX specification do not set the fault flag. Frequencies in between might set the flag.
- (4) Measured with logic-level input frequency but also applies to operation with crystals.

Internal Very-Low-Power Low-Frequency Oscillator (VLO)

over recommended ranges of supply voltage and operating free-air temperature (unless otherwise noted)

PARAMETER		T _A	V _{CC}	MIN	TYP	MAX	UNIT
f _{VLO}	VLO frequency	-40°C to 85°C	2.2 V, 3 V	4	12	20	kHz
		105°C					
df _{VLO} /dT	VLO frequency temperature drift ⁽¹⁾		2.2 V, 3 V		0.5		%/°C
df _{VLO} /dV _{CC}	VLO frequency supply voltage drift ⁽²⁾	25°C	1.8 V to 3.6 V		4		%/V

- (1) Calculated using the box method:
 I: (MAX(-40 to 85°C) - MIN(-40 to 85°C)) / MIN(-40 to 85°C) / (85°C - (-40°C))
 T: (MAX(-40 to 105°C) - MIN(-40 to 105°C)) / MIN(-40 to 105°C) / (105°C - (-40°C))
- (2) Calculated using the box method: (MAX(1.8 to 3.6 V) - MIN(1.8 to 3.6 V)) / MIN(1.8 to 3.6 V) / (3.6 V - 1.8 V)

Crystal Oscillator LFXT1, High-Frequency Mode⁽¹⁾

PARAMETER		TEST CONDITIONS	V _{CC}	MIN	TYP	MAX	UNIT
f _{LFXT1,HF0}	LFXT1 oscillator crystal frequency, HF mode 0	XTS = 1, LFXT1Sx = 0, XCAPx = 0	1.8 V to 3.6 V	0.4		1	MHz
f _{LFXT1,HF1}	LFXT1 oscillator crystal frequency, HF mode 1	XTS = 1, LFXT1Sx = 1, XCAPx = 0	1.8 V to 3.6 V	1		4	MHz
f _{LFXT1,HF2}	LFXT1 oscillator crystal frequency, HF mode 2	XTS = 1, LFXT1Sx = 2, XCAPx = 0	1.8 V to 3.6 V	2		10	MHz
			2.2 V to 3.6 V	2		12	
			3 V to 3.6 V	2		16	
f _{LFXT1,HF,logic}	LFXT1 oscillator logic-level square-wave input frequency, HF mode	XTS = 1, LFXT1Sx = 3, XCAPx = 0	1.8 V to 3.6 V	0.4		10	MHz
			2.2 V to 3.6 V	0.4		12	
			3 V to 3.6 V	0.4		16	
OA _{HF}	Oscillation allowance for HF crystals (see Figure 23 and Figure 24)	XTS = 1, XCAPx = 0, LFXT1Sx = 0, f _{LFXT1,HF} = 1 MHz, C _{L,eff} = 15 pF		2700			Ω
		XTS = 1, XCAPx = 0, LFXT1Sx = 1, f _{LFXT1,HF} = 4 MHz, C _{L,eff} = 15 pF		800			
		XTS = 1, XCAPx = 0, LFXT1Sx = 2, f _{LFXT1,HF} = 16 MHz, C _{L,eff} = 15 pF		300			
C _{L,eff}	Integrated effective load capacitance, HF mode ⁽²⁾	XTS = 1, XCAPx = 0 ⁽³⁾		1			pF
	Duty cycle, HF mode	XTS = 1, XCAPx = 0, Measured at P2.0/ACLK, f _{LFXT1,HF} = 10 MHz	2.2 V, 3 V	40	50	60	%
		XTS = 1, XCAPx = 0, Measured at P2.0/ACLK, f _{LFXT1,HF} = 16 MHz		40	50	60	
f _{Fault,HF}	Oscillator fault frequency ⁽⁴⁾	XTS = 1, LFXT1Sx = 3, XCAPx = 0 ⁽⁵⁾	2.2 V, 3 V	30		300	kHz

- (1) To improve EMI on the XT2 oscillator the following guidelines should be observed:
 - (a) Keep the trace between the device and the crystal as short as possible.
 - (b) Design a good ground plane around the oscillator pins.
 - (c) Prevent crosstalk from other clock or data lines into oscillator pins XIN and XOUT.
 - (d) Avoid running PCB traces underneath or adjacent to the XIN and XOUT pins.
 - (e) Use assembly materials and praxis to avoid any parasitic load on the oscillator XIN and XOUT pins.
 - (f) If conformal coating is used, ensure that it does not induce capacitive or resistive leakage between the oscillator pins.
 - (g) Do not route the XOUT line to the JTAG header to support the serial programming adapter as shown in other documentation. This signal is no longer required for the serial programming adapter.
- (2) Includes parasitic bond and package capacitance (approximately 2 pF per pin). Because the PCB adds additional capacitance, it is recommended to verify the correct load by measuring the ACLK frequency. For a correct setup, the effective load capacitance should always match the specification of the used crystal.
- (3) Requires external capacitors at both terminals. Values are specified by crystal manufacturers.
- (4) Frequencies below the MIN specification set the fault flag, frequencies above the MAX specification do not set the fault flag, and frequencies in between might set the flag.
- (5) Measured with logic-level input frequency, but also applies to operation with crystals.

Typical Characteristics - LFXT1 Oscillator in HF Mode (XTS = 1)

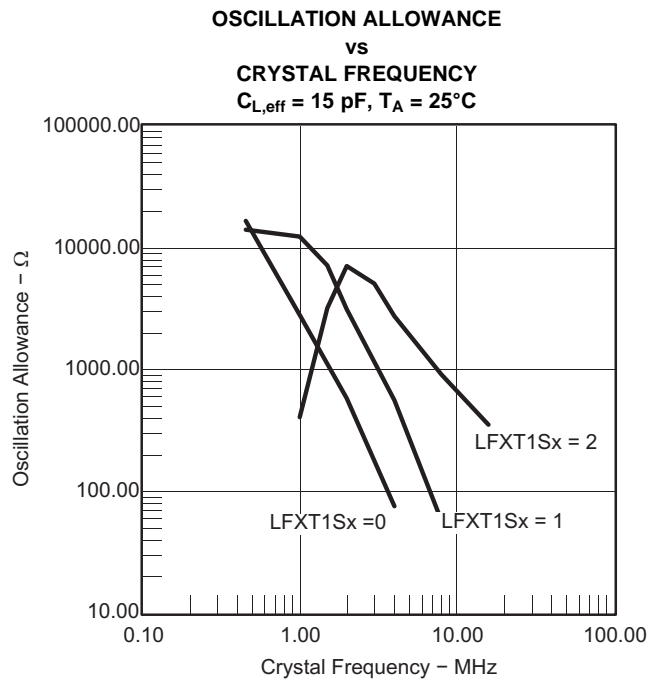

Figure 23.

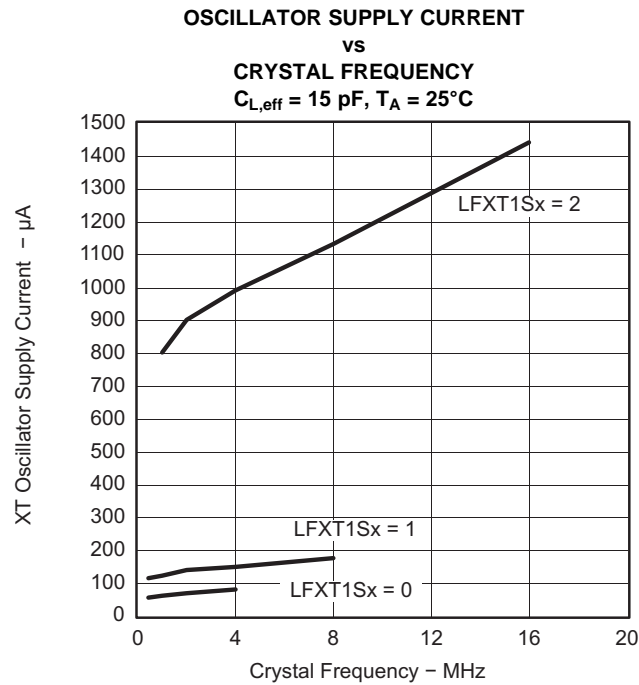

Figure 24.

Crystal Oscillator XT2⁽¹⁾

PARAMETER		TEST CONDITIONS	V _{CC}	MIN	TYP	MAX	UNIT
f _{XT2}	XT2 oscillator crystal frequency, mode 0	XT2Sx = 0	1.8 V to 3.6 V	0.4		1	MHz
f _{XT2}	XT2 oscillator crystal frequency, mode 1	XT2Sx = 1	1.8 V to 3.6 V	1		4	MHz
f _{XT2}	XT2 oscillator crystal frequency, mode 2	XT2Sx = 2	1.8 V to 2.2 V	2		10	MHz
			2.2 V to 3.6 V	2		12	
			3 V to 3.6 V	2		16	
f _{XT2}	XT2 oscillator logic-level square-wave input frequency	XT2Sx = 3	1.8 V to 2.2 V	0.4		10	MHz
			2.2 V to 3.6 V	0.4		12	
			3 V to 3.6 V	0.4		16	
OA	Oscillation allowance (see Figure 25 and Figure 26)	XT2Sx = 0, f _{XT2} = 1 MHz, C _{L,eff} = 15 pF			2700		Ω
		XT2Sx = 1, f _{XT2} = 4 MHz, C _{L,eff} = 15 pF			800		
		XT2Sx = 2, f _{XT2} = 16 MHz, C _{L,eff} = 15 pF			300		
C _{L,eff}	Integrated effective load capacitance, HF mode ⁽²⁾	See ⁽³⁾			1		pF
	Duty cycle	Measured at P1.4/SMCLK, f _{XT2} = 10 MHz	2.2 V, 3 V	40	50	60	%
		Measured at P1.4/SMCLK, f _{XT2} = 16 MHz		40	50	60	
f _{Fault}	Oscillator fault frequency, HF mode ⁽⁴⁾	XT2Sx = 3 ⁽⁵⁾	2.2 V, 3 V	30		300	kHz

- (1) To improve EMI on the XT2 oscillator the following guidelines should be observed:
 - (a) Keep the trace between the device and the crystal as short as possible.
 - (b) Design a good ground plane around the oscillator pins.
 - (c) Prevent crosstalk from other clock or data lines into oscillator pins XT2IN and XT2OUT.
 - (d) Avoid running PCB traces underneath or adjacent to the XT2IN and XT2OUT pins.
 - (e) Use assembly materials and praxis to avoid any parasitic load on the oscillator XT2IN and XT2OUT pins.
 - (f) If conformal coating is used, ensure that it does not induce capacitive or resistive leakage between the oscillator pins.
- (2) Includes parasitic bond and package capacitance (approximately 2 pF per pin). Because the PCB adds additional capacitance, it is recommended to verify the correct load by measuring the ACLK frequency. For a correct setup, the effective load capacitance should always match the specification of the used crystal.
- (3) Requires external capacitors at both terminals. Values are specified by crystal manufacturers.
- (4) Frequencies below the MIN specification set the fault flag, frequencies above the MAX specification do not set the fault flag, and frequencies in between might set the flag.
- (5) Measured with logic-level input frequency, but also applies to operation with crystals.

Typical Characteristics - XT2 Oscillator

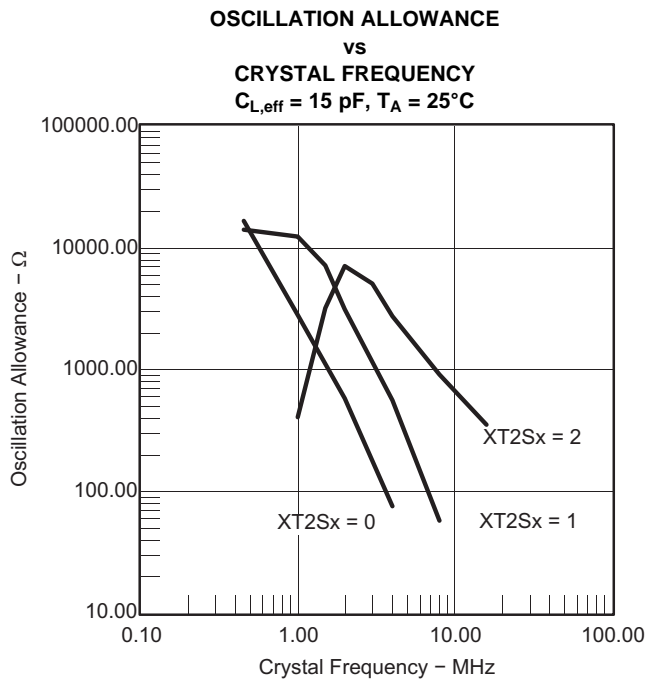

Figure 25.

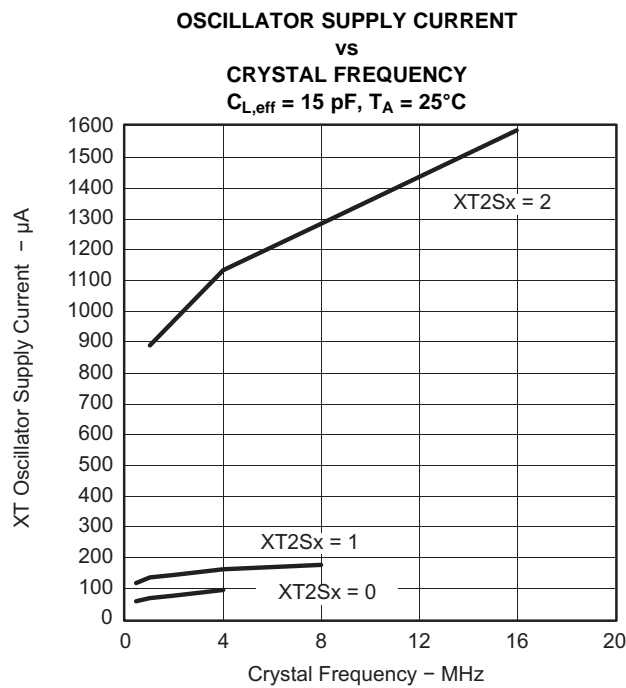

Figure 26.

Timer_A

over recommended ranges of supply voltage and operating free-air temperature (unless otherwise noted)

PARAMETER		TEST CONDITIONS	V _{CC}	MIN	TYP	MAX	UNIT
f _{TA}	Timer_A clock frequency	Internal: SMCLK, ACLK External: TACLK, INCLK Duty cycle = 50% ± 10%	2.2 V			10	MHz
			3 V			16	
t _{TA,cap}	Timer_A capture timing	TA0, TA1, TA2	2.2 V, 3 V	20			ns

Timer_B

over recommended ranges of supply voltage and operating free-air temperature (unless otherwise noted)

PARAMETER		TEST CONDITIONS	V _{CC}	MIN	TYP	MAX	UNIT
f _{TB}	Timer_B clock frequency	Internal: SMCLK, ACLK External: TACLK, INCLK Duty cycle = 50% ± 10%	2.2 V			10	MHz
			3 V			16	
t _{TB,cap}	Timer_B capture timing	TB0, TB1, TB2	2.2 V, 3 V	20			ns

USCI (UART Mode)

over recommended ranges of supply voltage and operating free-air temperature (unless otherwise noted)

PARAMETER		CONDITIONS	V _{CC}	MIN	TYP	MAX	UNIT
f _{USCI}	USCI input clock frequency	Internal: SMCLK, ACLK External: UCLK Duty cycle = 50% ± 10%				f _{SYSTEM}	MHz
f _{BITCLK}	BITCLK clock frequency (equals baud rate in Mbaud) ⁽¹⁾		2.2 V, 3 V			1	MHz
t _r	UART receive deglitch time ⁽²⁾		2.2 V	50	150	600	ns
			3 V	50	100	600	

(1) The DCO wake-up time must be considered in LPM3 or LPM4 for baud rates above 1 MHz.

(2) Pulses on the UART receive input (UCxRX) shorter than the UART receive deglitch time are suppressed.

USCI (SPI Master Mode)⁽¹⁾

over recommended ranges of supply voltage and operating free-air temperature (unless otherwise noted)

(see [Figure 27](#) and [Figure 28](#))

PARAMETER		TEST CONDITIONS	V _{CC}	MIN	MAX	UNIT
f _{USCI}	USCI input clock frequency	SMCLK, ACLK Duty cycle = 50% ± 10%			f _{SYSTEM}	MHz
t _{SU,MI}	SOMI input data setup time		2.2 V	110		ns
			3 V	75		
t _{HD,MI}	SOMI input data hold time		2.2 V	0		ns
			3 V	0		
t _{VALID,MO}	SIMO output data valid time	UCLK edge to SIMO valid, C _L = 20 pF	2.2 V		30	ns
			3 V		20	

(1) f_{UCxCLK} = 1/2t_{LO/HI} with t_{LO/HI} ≥ max(t_{VALID,MO(USCI)} + t_{SU,SI(Slave)}, t_{SU,MI(USCI)} + t_{VALID,SO(Slave)}).

For the slave's parameters t_{SU,SI(Slave)} and t_{VALID,SO(Slave)}, see the SPI parameters of the attached slave.

USCI (SPI Slave Mode)⁽¹⁾

over recommended ranges of supply voltage and operating free-air temperature (unless otherwise noted)

(see [Figure 29](#) and [Figure 30](#))

PARAMETER		TEST CONDITIONS	V _{CC}	MIN	TYP	MAX	UNIT
t _{STE,LEAD}	STE lead time, STE low to clock		2.2 V, 3 V		50		ns
t _{STE,LAG}	STE lag time, Last clock to STE high		2.2 V, 3 V	10			ns
t _{STE,ACC}	STE access time, STE low to SOMI data out		2.2 V, 3 V		50		ns
t _{STE,DIS}	STE disable time, STE high to SOMI high impedance		2.2 V, 3 V		50		ns
t _{SU,SI}	SIMO input data setup time		2.2 V	20			ns
			3 V	15			
t _{HD,SI}	SIMO input data hold time		2.2 V	10			ns
			3 V	10			
t _{VALID,SO}	SOMI output data valid time	UCLK edge to SOMI valid, C _L = 20 pF	2.2 V		75	110	ns
			3 V		50	75	

(1) f_{UCxCLK} = 1/2t_{LO/HI} with t_{LO/HI} ≥ max(t_{VALID,MO(Master)} + t_{SU,SI(USCI)}, t_{SU,MI(Master)} + t_{VALID,SO(USCI)}).

For the master's parameters t_{SU,MI(Master)} and t_{VALID,MO(Master)} see the SPI parameters of the attached slave.

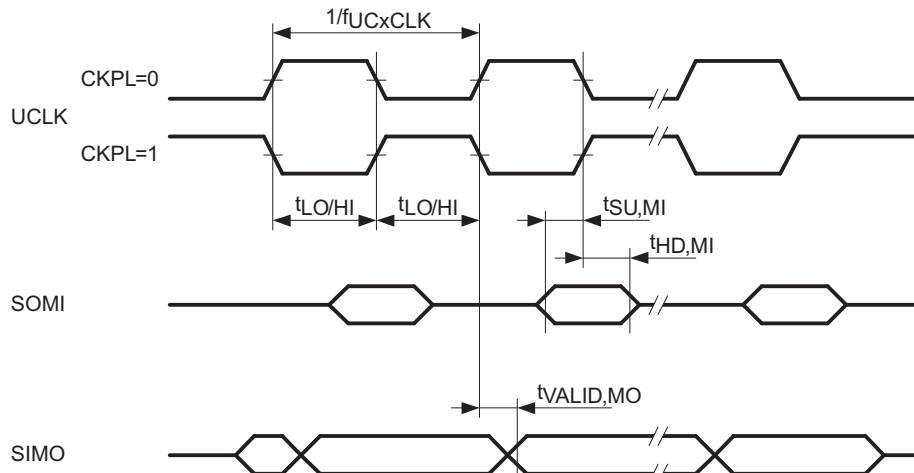

Figure 27. SPI Master Mode, CKPH = 0

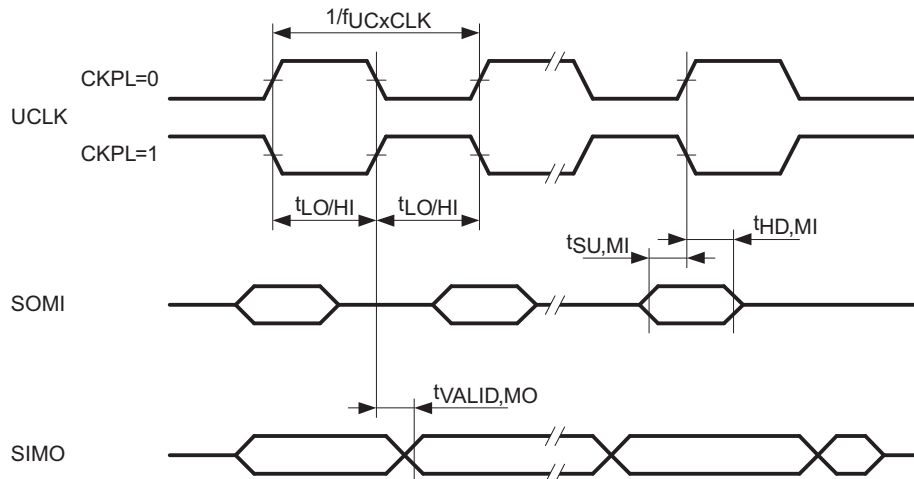

Figure 28. SPI Master Mode, CKPH = 1

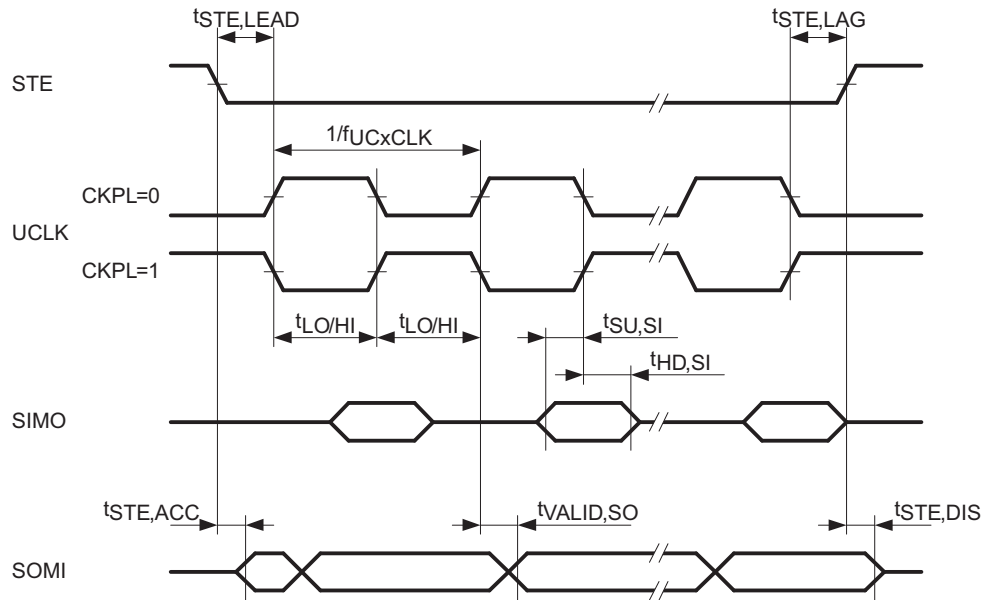

Figure 29. SPI Slave Mode, CKPH = 0

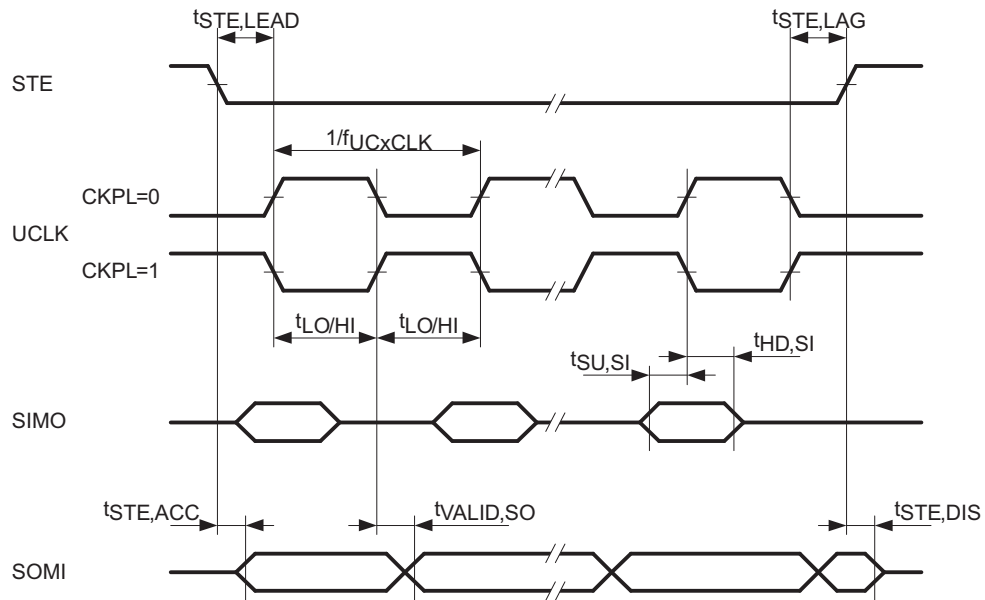

Figure 30. SPI Slave Mode, CKPH = 1

USCI (I²C Mode)

over recommended ranges of supply voltage and operating free-air temperature (unless otherwise noted) (see [Figure 31](#))

PARAMETER	TEST CONDITIONS	V _{CC}	MIN	TYP	MAX	UNIT	
f _{USCI}	USCI input clock frequency				f _{SYSTEM}	MHz	
f _{SCL}	SCL clock frequency	2.2 V, 3 V	0		400	kHz	
t _{HD,STA}	Hold time (repeated) START	f _{SCL} ≤ 100 kHz f _{SCL} > 100 kHz	2.2 V, 3 V	4 0.6		μs	
t _{SU,STA}	Setup time for a repeated START	f _{SCL} ≤ 100 kHz f _{SCL} > 100 kHz	2.2 V, 3 V	4.7 0.6		μs	
t _{HD,DAT}	Data hold time		2.2 V, 3 V	0		ns	
t _{SU,DAT}	Data setup time		2.2 V, 3 V	250		ns	
t _{SU,STO}	Setup time for STOP		2.2 V, 3 V	4		μs	
t _{SP}	Pulse duration of spikes suppressed by input filter		2.2 V 3 V	50 50	150 100	600 600	ns

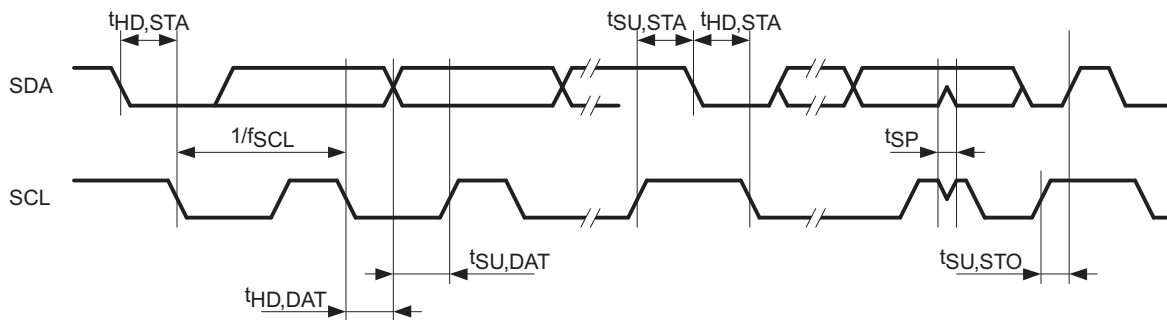

Figure 31. I²C Mode Timing

Comparator_A+⁽¹⁾

over recommended operating free-air temperature range (unless otherwise noted)

PARAMETER	TEST CONDITIONS	V _{CC}	MIN	TYP	MAX	UNIT	
I _(DD)	CAON = 1, CARSEL = 0, CAREF = 0	2.2 V		25	40	μA	
		3 V		45	60		
I _(Refladder/RefDiode)	CAON = 1, CARSEL = 0, CAREF = 1/2/3, No load at P2.3/CA0/TA1 and P2.4/CA1/TA2	2.2 V		30	50	μA	
		3 V		45	71		
V _{IC}	Common-mode input voltage range CAON = 1	2.2 V, 3 V	0		V _{CC} - 1	V	
V _(Ref025)	(Voltage at 0.25 V _{CC} node) ÷ V _{CC} PCA0 = 1, CARSEL = 1, CAREF = 1, No load at P2.3/CA0/TA1 and P2.4/CA1/TA2	2.2 V, 3 V	0.23	0.24	0.25		
V _(Ref050)	(Voltage at 0.5 V _{CC} node) ÷ V _{CC} PCA0 = 1, CARSEL = 1, CAREF = 2, No load at P2.3/CA0/TA1 and P2.4/CA1/TA2	2.2 V, 3 V	0.47	0.48	0.5		
V _(RefVT)	See Figure 35 and Figure 36 PCA0 = 1, CARSEL = 1, CAREF = 3, No load at P2.3/CA0/TA1 and P2.4/CA1/TA2, T _A = 85°C	2.2 V	390	480	540	mV	
		3 V	400	490	550		
V _(offset)	Offset voltage ⁽²⁾	2.2 V, 3 V	-30		30	mV	
V _{hys}	Input hysteresis CAON = 1	2.2 V, 3 V	0	0.7	1.4	mV	
t _(response)	Response time, low to high and high to low ⁽³⁾ (see Figure 32 and Figure 33)	T _A = 25°C, Overdrive 10 mV, Without filter: CAF = 0	2.2 V	80	165	300	ns
			3 V	70	120	240	
		T _A = 25°C, Overdrive 10 mV, With filter: CAF = 1	2.2 V	1.4	1.9	2.8	μs
			3 V	0.9	1.5	2.2	

- (1) The leakage current for the Comparator_A+ terminals is identical to I_{lkg(Px,y)} specification.
- (2) The input offset voltage can be cancelled by using the CAEX bit to invert the Comparator_A+ inputs on successive measurements. The two successive measurements are then summed together.
- (3) The response time is measured at P2.2/CAOUT/TA0/CA4 with an input voltage step and with Comparator_A+ already enabled (CAON = 1). If CAON is set at the same time, a settling time of up to 300 ns is added to the response time.

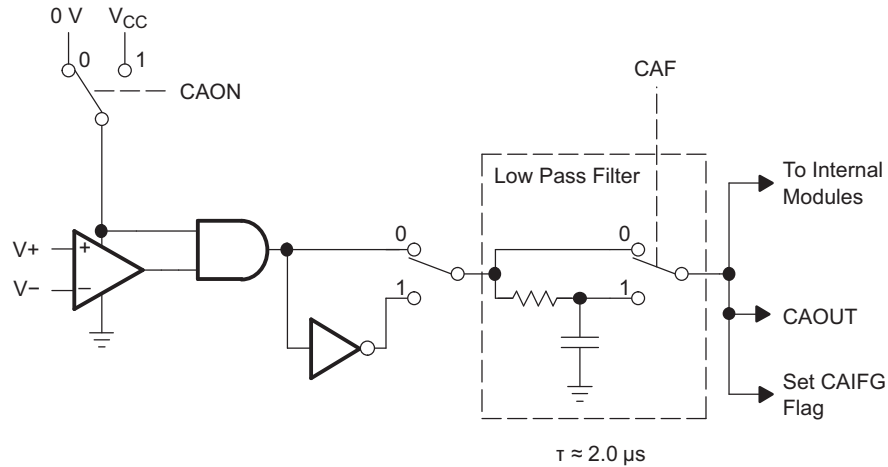

Figure 32. Comparator_A+ Module Block Diagram

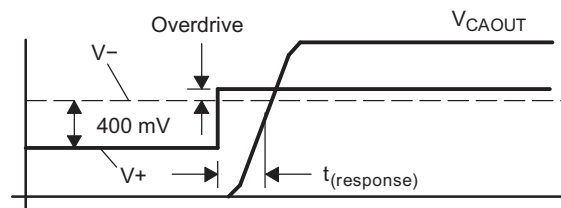

Figure 33. Overdrive Definition

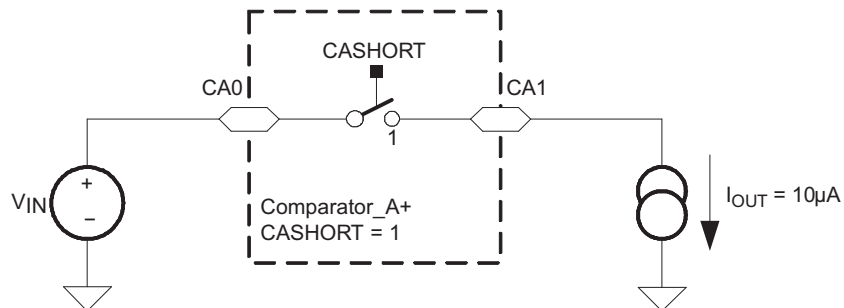

Figure 34. Comparator_A+ Short Resistance Test Condition

Typical Characteristics, Comparator_A+

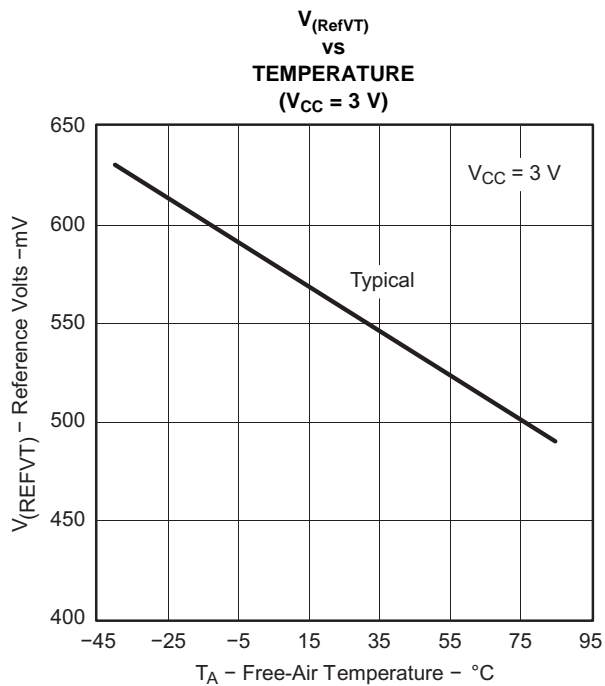

Figure 35.

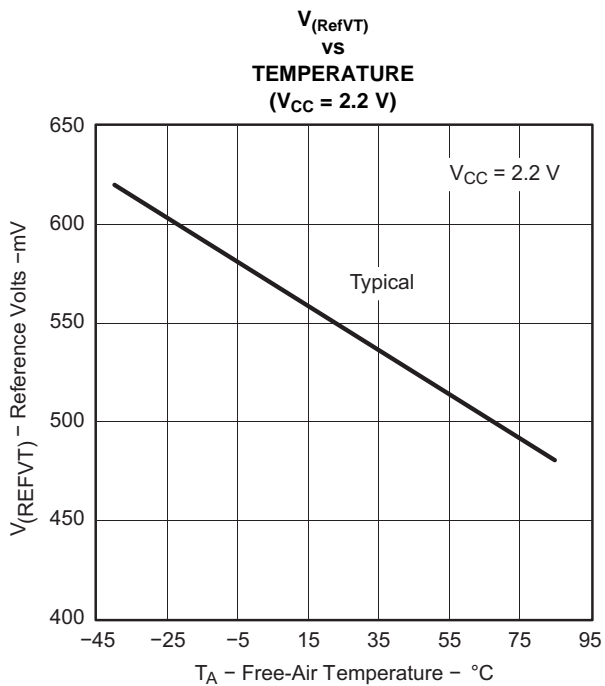

Figure 36.

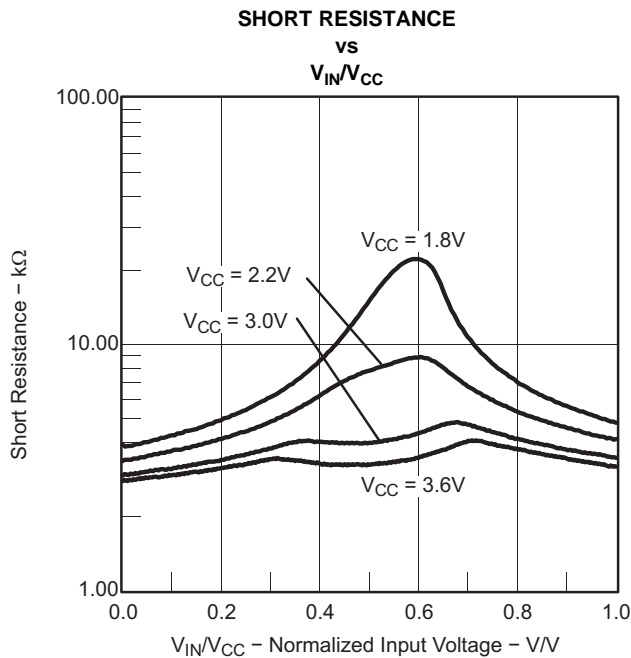

Figure 37.

12-Bit ADC Power Supply and Input Range Conditions ⁽¹⁾

over recommended operating free-air temperature range (unless otherwise noted)

PARAMETER	TEST CONDITIONS	V _{CC}	MIN	TYP	MAX	UNIT
AV _{CC} Analog supply voltage	AV _{CC} and DV _{CC} are connected together, AV _{SS} and DV _{SS} are connected together, V _(AVSS) = V _(DVSS) = 0 V		2.2		3.6	V
V _(P6.x/Ax) Analog input voltage range ⁽²⁾	All P6.0/A0 to P6.7/A7 terminals, Analog inputs selected in ADC12MCTLx register, P6Sel.x = 1, 0 ≤ x ≤ 7, V _(AVSS) ≤ V _{P6.x/Ax} ≤ V _(AVCC)		0		V _{AVCC}	V
I _{ADC12} Operating supply current into AV _{CC} terminal ⁽³⁾	f _{ADC12CLK} = 5 MHz, ADC12ON = 1, REFON = 0, SHT0 = 0, SHT1 = 0, ADC12DIV = 0	2.2 V		0.65	0.8	mA
		3 V		0.8	1	
I _{REF+} Operating supply current into AV _{CC} terminal ⁽⁴⁾	f _{ADC12CLK} = 5 MHz, ADC12ON = 0, REFON = 1, REF2_5V = 1	3 V		0.5	0.7	mA
	f _{ADC12CLK} = 5 MHz, ADC12ON = 0, REFON = 1, REF2_5V = 0	2.2 V		0.5	0.7	
		3 V		0.5	0.7	mA
C _I Input capacitance ⁽⁵⁾	Only one terminal can be selected at one time, P6.x/Ax	2.2 V			40	
R _I Input MUX ON resistance ⁽⁵⁾	0 V ≤ V _{Ax} ≤ V _{AVCC}	3 V			2000	Ω

- (1) The leakage current is defined in the leakage current table with P6.x/Ax parameter.
- (2) The analog input voltage range must be within the selected reference voltage range V_{R+} to V_{R-} for valid conversion results.
- (3) The internal reference supply current is not included in current consumption parameter I_{ADC12}.
- (4) The internal reference current is supplied via terminal AV_{CC}. Consumption is independent of the ADC12ON control bit, unless a conversion is active. The REFON bit enables settling of the built-in reference before starting an A/D conversion.
- (5) Not production tested, limits verified by design.

12-Bit ADC External Reference ⁽¹⁾

over recommended operating free-air temperature range (unless otherwise noted)

PARAMETER	TEST CONDITIONS	V _{CC}	MIN	MAX	UNIT
V _{eREF+} Positive external reference voltage input	V _{eREF+} > V _{REF} /V _{eREF-} ⁽²⁾		1.4	V _{AVCC}	V
V _{REF} /V _{eREF-} Negative external reference voltage input	V _{eREF+} > V _{REF} /V _{eREF-} ⁽³⁾		0	1.2	V
(V _{eREF+} - V _{REF-})/V _{eREF-} Differential external reference voltage input	V _{eREF+} > V _{REF} /V _{eREF-} ⁽⁴⁾		1.4	V _{AVCC}	V
I _{vREF+} Static leakage current	0 V ≤ V _{eREF+} ≤ V _{AVCC}	2.2 V, 3 V		±1	μA
I _{vREF-/V_{eREF-}} Static leakage current	0 V ≤ V _{eREF-} ≤ V _{AVCC}	2.2 V, 3 V		±1	μA

- (1) The external reference is used during conversion to charge and discharge the capacitance array. The input capacitance, C_I, is also the dynamic load for an external reference during conversion. The dynamic impedance of the reference supply should follow the recommendations on analog-source impedance to allow the charge to settle for 12-bit accuracy.
- (2) The accuracy limits the minimum positive external reference voltage. Lower reference voltage levels may be applied with reduced accuracy requirements.
- (3) The accuracy limits the maximum negative external reference voltage. Higher reference voltage levels may be applied with reduced accuracy requirements.
- (4) The accuracy limits minimum external differential reference voltage. Lower differential reference voltage levels may be applied with reduced accuracy requirements.

12-Bit ADC Built-In Reference

over recommended operating free-air temperature range (unless otherwise noted)

PARAMETER	TEST CONDITIONS	T _A	V _{CC}	MIN	NOM	MAX	UNIT	
V _{REF+}	Positive built-in reference voltage output	REF2_5V = 1 for 2.5 V, I _{VREF+} max ≤ I _{VREF+} ≤ I _{VREF+} min	3 V	-40°C to 85°C	2.4	2.5	2.6	V
				105°C	2.37	2.5	2.64	
	REF2_5V = 0 for 1.5 V, I _{VREF+} max ≤ I _{VREF+} ≤ I _{VREF+} min	2.2 V, 3 V	-40°C to 85°C	1.44	1.5	1.56		
			105°C	1.42	1.5	1.57		
AV _{CC(min)}	AV _{CC} minimum voltage, positive built-in reference active	REF2_5V = 0, I _{VREF+} max ≤ I _{VREF+} ≤ I _{VREF+} min			2.2		V	
		REF2_5V = 1, -0.5 mA ≤ I _{VREF+} ≤ I _{VREF+} min			2.8			
		REF2_5V = 1, -1 mA ≤ I _{VREF+} ≤ I _{VREF+} min			2.9			
I _{VREF+}	Load current out of V _{REF+} terminal		2.2 V	0.01		-0.5	mA	
			3 V	0.01		-1		
I _{L(VREF)+}	Load-current regulation, V _{REF+} terminal ⁽¹⁾	I _{VREF+} = 500 μA ± 100 μA, Analog input voltage ≈ 0.75 V, REF2_5V = 0	2.2 V			±2	LSB	
			3 V			±2		
		I _{VREF+} = 500 μA ± 100 μA, Analog input voltage ≈ 1.25 V, REF2_5V = 1	3 V			±2	LSB	
I _{DL(VREF)+}	Load current regulation, V _{REF+} terminal ⁽²⁾	I _{VREF+} = 100 μA → 900 μA, C _{VREF+} = 5 μF, ax ≈ 0.5 × V _{REF+} , Error of conversion result ≤ 1 LSB	3 V			20	ns	
C _{VREF+}	Capacitance at pin V _{REF+} ⁽³⁾	REFON = 1, 0 mA ≤ I _{VREF+} ≤ I _{VREF+} max	2.2 V, 3 V	5	10		μF	
T _{REF+}	Temperature coefficient of built-in reference ⁽²⁾	I _{VREF+} is a constant in the range of 0 mA ≤ I _{VREF+} ≤ 1 mA	2.2 V, 3 V			±100	ppm/°C	
t _{REFON}	Settle time of internal reference voltage (see Figure 38) ⁽⁴⁾ ⁽²⁾	I _{VREF+} = 0.5 mA, C _{VREF+} = 10 μF, V _{REF+} = 1.5 V, V _{AVCC} = 2.2 V	2.2 V			17	ms	

(1) Not production tested, limits characterized.

(2) Not production tested, limits verified by design.

(3) The internal buffer operational amplifier and the accuracy specifications require an external capacitor. All INL and DNL tests uses two capacitors between pins V_{REF+} and AV_{SS} and V_{REF-}/V_{REF-} and AV_{SS}: 10 μF tantalum and 100 nF ceramic.

(4) The condition is that the error in a conversion started after t_{REFON} is less than ±0.5 LSB. The settling time depends on the external capacitive load.

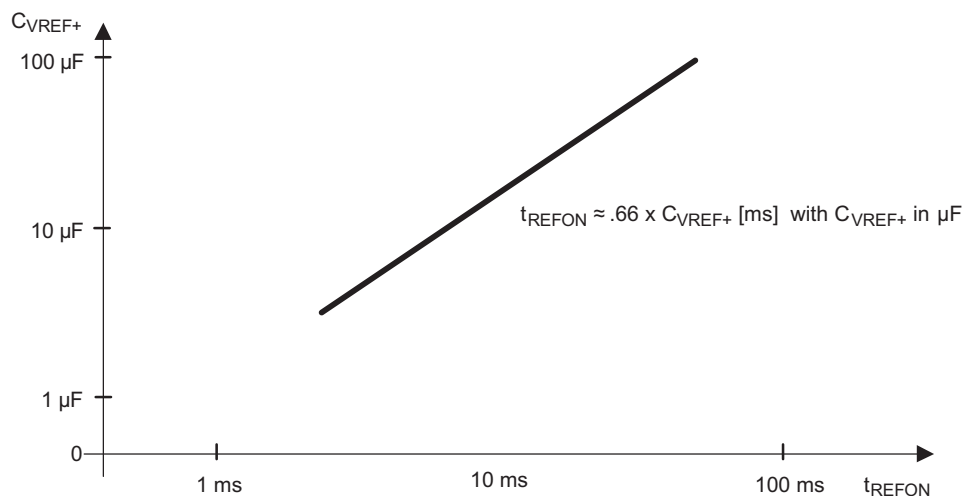

Figure 38. Typical Settling Time of Internal Reference t_{REFON} vs External Capacitor on V_{REF+}

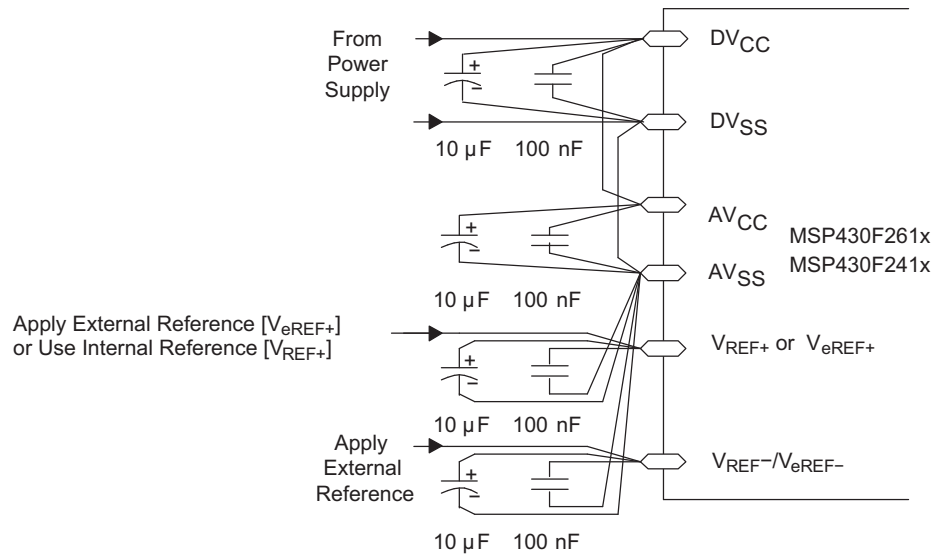

Figure 39. Supply Voltage and Reference Voltage Design V_{REF-}/V_{eREF-} External Supply

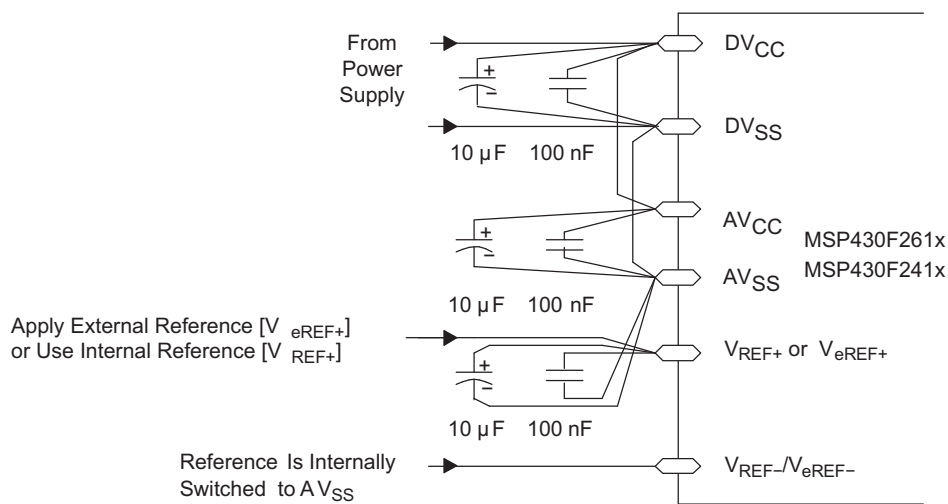

Figure 40. Supply Voltage and Reference Voltage Design $V_{REF-}/V_{eREF-} = AV_{SS}$, Internally Connected

12-Bit ADC Timing Parameters

over recommended operating free-air temperature range (unless otherwise noted)

PARAMETER	TEST CONDITIONS	V _{CC}	MIN	TYP	MAX	UNIT
f _{ADC12CLK}	For specified performance of ADC12 linearity parameters	2.2 V, 3 V	0.45	5	6.3	MHz
f _{ADC12OSC}	Internal ADC12 oscillator ADC12DIV = 0, f _{ADC12CLK} = f _{ADC12OSC}	2.2 V, 3 V	3.7	5	6.3	MHz
t _{CONVERT}	C _{VREF+} ≥ 5 μF, Internal oscillator, f _{ADC12OSC} = 3.7 MHz to 6.3 MHz	2.2 V, 3 V	2.06		3.51	μs
	External f _{ADC12CLK} from ACLK, MCLK, or SMCLK, ADC12SSEL ≠ 0			13 × ADC12DIV × 1/f _{ADC12CLK}		μs
t _{ADC12ON}	Turn-on settling time of the ADC ⁽¹⁾	See ⁽²⁾			100	ns
t _{Sample}	Sampling time ⁽¹⁾ R _S = 400 Ω, R _I = 1000 Ω, C _I = 30 pF, τ = [R _S + R _I] × C _I ⁽³⁾	3 V	1220			ns
		2.2 V	1400			

(1) Limits verified by design

(2) The condition is that the error in a conversion started after t_{ADC12ON} is less than ±0.5 LSB. The reference and input signal are already settled.

(3) Approximately ten Tau (τ) are needed to get an error of less than ±0.5 LSB:

$$t_{\text{sample}} = \ln(2^{n+1}) \times (R_S + R_I) \times C_I + 800 \text{ ns, where } n = \text{ADC resolution} = 12, R_S = \text{external source resistance}$$

12-Bit ADC Linearity Parameters

over recommended operating free-air temperature range (unless otherwise noted)

PARAMETER	TEST CONDITIONS	V _{CC}	MIN	TYP	MAX	UNIT
E _I	1.4 V ≤ (V _{eREF+} - V _{REF-/V_{eREF-}}) min ≤ 1.6 V	2.2 V, 3 V			±2	LSB
	1.6 V < (V _{eREF+} - V _{REF-/V_{eREF-}}) min ≤ V _{AVCC}				±1.7	
E _D	(V _{eREF+} - V _{REF-/V_{eREF-}}) min ≤ (V _{eREF+} - V _{REF-/V_{eREF-}}), C _{VREF+} = 10 μF (tantalum) and 100 nF (ceramic)	2.2 V, 3 V			±1	LSB
E _O	(V _{eREF+} - V _{REF-/V_{eREF-}}) min ≤ (V _{eREF+} - V _{REF-/V_{eREF-}}), Internal impedance of source R _S < 100 Ω, C _{VREF+} = 10 μF (tantalum) and 100 nF (ceramic)	2.2 V, 3 V		±2	±4	LSB
E _G	(V _{eREF+} - V _{REF-/V_{eREF-}}) min ≤ (V _{eREF+} - V _{REF-/V_{eREF-}}), C _{VREF+} = 10 μF (tantalum) and 100 nF (ceramic)	2.2 V, 3 V		±1.1	±2	LSB
E _T	(V _{eREF+} - V _{REF-/V_{eREF-}}) min ≤ (V _{eREF+} - V _{REF-/V_{eREF-}}), C _{VREF+} = 10 μF (tantalum) and 100 nF (ceramic)	2.2 V, 3 V		±2	±5	LSB

12-Bit ADC Temperature Sensor and Built-In V_{MID}

over recommended operating free-air temperature range (unless otherwise noted)

PARAMETER		TEST CONDITIONS	V_{CC}	MIN	TYP	MAX	UNIT
I_{SENSOR}	Operating supply current into AV_{CC} terminal ⁽¹⁾	REFON = 0, INCH = 0Ah, ADC12ON = 1, $T_A = 25^{\circ}C$	2.2 V		40	120	μA
			3V		60	160	
V_{SENSOR} ^{(2) (3)}		ADC12ON = 1, INCH = 0Ah, $T_A = 0^{\circ}C$	2.2 V		986		mV
			3V		986		
TC_{SENSOR} ⁽³⁾		ADC12ON = 1, INCH = 0Ah	2.2 V		3.55		mV/ $^{\circ}C$
			3V		3.55		
$t_{SENSOR(sample)}$ ⁽³⁾	Sample time required if channel 10 is selected ⁽⁴⁾	ADC12ON = 1, INCH = 0Ah, Error of conversion result ≤ 1 LSB	2.2 V		30		μs
			3V		30		
I_{VMID}	Current into divider at channel 11 ⁽⁵⁾	ADC12ON = 1, INCH = 0Bh	2.2 V			NA ⁽⁵⁾	μA
			3V			NA ⁽⁵⁾	
V_{MID}	AV_{CC} divider at channel 11	ADC12ON = 1, INCH = 0Bh, V_{MID} is approximately $0.5 \times V_{AVCC}$	2.2 V		1.1	1.1 ± 0.04	V
			3V		1.5	1.5 ± 0.04	
$t_{VMID(sample)}$	Sample time required if channel 11 is selected ⁽⁶⁾	ADC12ON = 1, INCH = 0Bh, Error of conversion result ≤ 1 LSB	2.2 V		1400		ns
			3 V		1220		

- (1) The sensor current I_{SENSOR} is consumed if (ADC12ON = 1 and REFON = 1), or (ADC12ON = 1 AND INCH = 0Ah and sample signal is high). Therefore it includes the constant current through the sensor and the reference.
- (2) The temperature sensor offset can be as much as $\pm 20^{\circ}C$. A single-point calibration is recommended to minimize the offset error of the built-in temperature sensor.
- (3) Limits characterized
- (4) The typical equivalent impedance of the sensor is 51 k Ω . The sample time required includes the sensor-on time $t_{SENSOR(on)}$
- (5) No additional current is needed. The V_{MID} is used during sampling.
- (6) The on-time $t_{VMID(on)}$ is included in the sampling time $t_{VMID(sample)}$, no additional on time is needed.

12-Bit DAC Supply Specifications

over recommended ranges of supply voltage and operating free-air temperature (unless otherwise noted)

PARAMETER		TEST CONDITIONS	V_{CC}	T_A	MIN	TYP	MAX	UNIT
AV_{CC}	Analog supply voltage	$AV_{CC} = DV_{CC}$, $AV_{SS} = DV_{SS} = 0$ V			2.2		3.6	V
I_{DD}	Supply current, single DAC channel ⁽¹⁾⁽²⁾	DAC12AMPx = 2, DAC12IR = 0, DAC12_xDAT = 0x0800	2.2 V, 3 V	-40 $^{\circ}C$ to 85 $^{\circ}C$		50	110	μA
						69	150	
		DAC12AMPx = 2, DAC12IR = 1, DAC12_xDAT = 0x0800, $V_{eREF+} = V_{REF+} = AV_{CC}$	2.2 V, 3 V			50	130	
		DAC12AMPx = 5, DAC12IR = 1, DAC12_xDAT = 0x0800, $V_{eREF+} = V_{REF+} = AV_{CC}$	2.2 V, 3 V			200	440	
		DAC12AMPx = 7, DAC12IR = 1, DAC12_xDAT = 0x0800, $V_{eREF+} = V_{REF+} = AV_{CC}$	2.2 V, 3 V			700	1500	
PSRR	Power-supply rejection ratio ⁽³⁾⁽⁴⁾	DAC12_xDAT = 800h, $V_{REF} = 1.5$ V, $\Delta AV_{CC} = 100$ mV	2.2 V			70		dB
		DAC12_xDAT = 800h, $V_{REF} = 1.5$ V or 2.5 V, $\Delta AV_{CC} = 100$ mV	3 V			70		

- (1) No load at the output pin, DAC12_0 or DAC12_1, assuming that the control bits for the shared pins are set properly.
- (2) Current into reference terminals not included. If DAC12IR = 1 current flows through the input divider; see Reference Input specifications.
- (3) $PSRR = 20 \times \log(\Delta AV_{CC} / \Delta V_{DAC12_xOUT})$
- (4) V_{REF} is applied externally. The internal reference is not used.

12-Bit DAC Linearity Specifications

over recommended ranges of supply voltage and operating free-air temperature (unless otherwise noted)

PARAMETER		TEST CONDITIONS	V _{CC}	MIN	TYP	MAX	UNIT
Resolution		12-bit monotonic		12			bits
INL	Integral nonlinearity ⁽¹⁾	V _{REF} = 1.5 V, DAC12AMPx = 7, DAC12IR = 1	2.2 V		±2.0	±8.0	LSB
		V _{REF} = 2.5 V, DAC12AMPx = 7, DAC12IR = 1	3 V				
DNL	Differential nonlinearity ⁽¹⁾	V _{REF} = 1.5 V, DAC12AMPx = 7, DAC12IR = 1	2.2 V		±0.4	±1.0	LSB
		V _{REF} = 2.5 V, DAC12AMPx = 7, DAC12IR = 1	3 V				
E _O	Offset voltage without calibration ⁽¹⁾⁽²⁾	V _{REF} = 1.5 V, DAC12AMPx = 7, DAC12IR = 1	2.2 V			±21	mV
		V _{REF} = 2.5 V, DAC12AMPx = 7, DAC12IR = 1	3 V				
	Offset voltage with calibration ⁽¹⁾⁽²⁾	V _{REF} = 1.5 V, DAC12AMPx = 7, DAC12IR = 1	2.2 V			±2.5	
		V _{REF} = 2.5 V, DAC12AMPx = 7, DAC12IR = 1	3 V				
d _{E(O)/dT}	Offset error temperature coefficient ⁽³⁾		2.2 V, 3 V		30		µV/C
E _G	Gain error ⁽³⁾	V _{REF} = 1.5 V	2.2 V			±3.50	% FSR
		V _{REF} = 2.5 V	3 V				
d _{E(G)/dT}	Gain temperature coefficient ⁽³⁾		2.2 V, 3 V		10		ppm of FSR/°C
t _{Offset_Cal}	Time for offset calibration ⁽⁴⁾	DAC12AMPx = 2	2.2 V, 3 V			100	ms
		DAC12AMPx = 3, 5				32	
		DAC12AMPx = 4, 6, 7				6	

- (1) Parameters calculated from the best-fit curve from 0x0A to 0xFFF. The best-fit curve method is used to deliver coefficients "a" and "b" of the first-order equation: $y = a + b \times x$. $V_{DAC12_xOUT} = E_O + (1 + E_G) \times (V_{eREF+}/4095) \times DAC12_xDAT$, DAC12IR = 1.
- (2) The offset calibration works on the output operational amplifier. Offset calibration is triggered setting bit DAC12CALON.
- (3) Parameters calculated from the best-fit curve from 0x0A to 0xFFF. The best-fit curve method is used to deliver coefficients "a" and "b" of the first-order equation: $y = a + b \times x$. $V_{DAC12_xOUT} = E_O + (1 + E_G) \times (V_{eREF+}/4095) \times DAC12_xDAT$, DAC12IR = 1.
- (4) The offset calibration can be done if DAC12AMPx = {2, 3, 4, 5, 6, 7}. The output operational amplifier is switched off with DAC12AMPx = {0, 1}. The DAC12 module should be configured prior to initiating calibration. Port activity during calibration may affect accuracy and is not recommended.

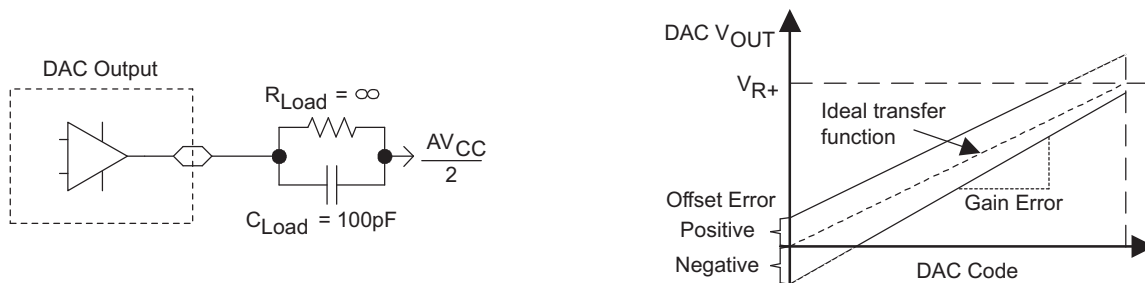

Figure 41. Linearity Test Load Conditions and Gain/Offset Definition

Typical Characteristics - 12-Bit DAC, Linearity Specifications

over recommended ranges of supply voltage and operating free-air temperature (unless otherwise noted)

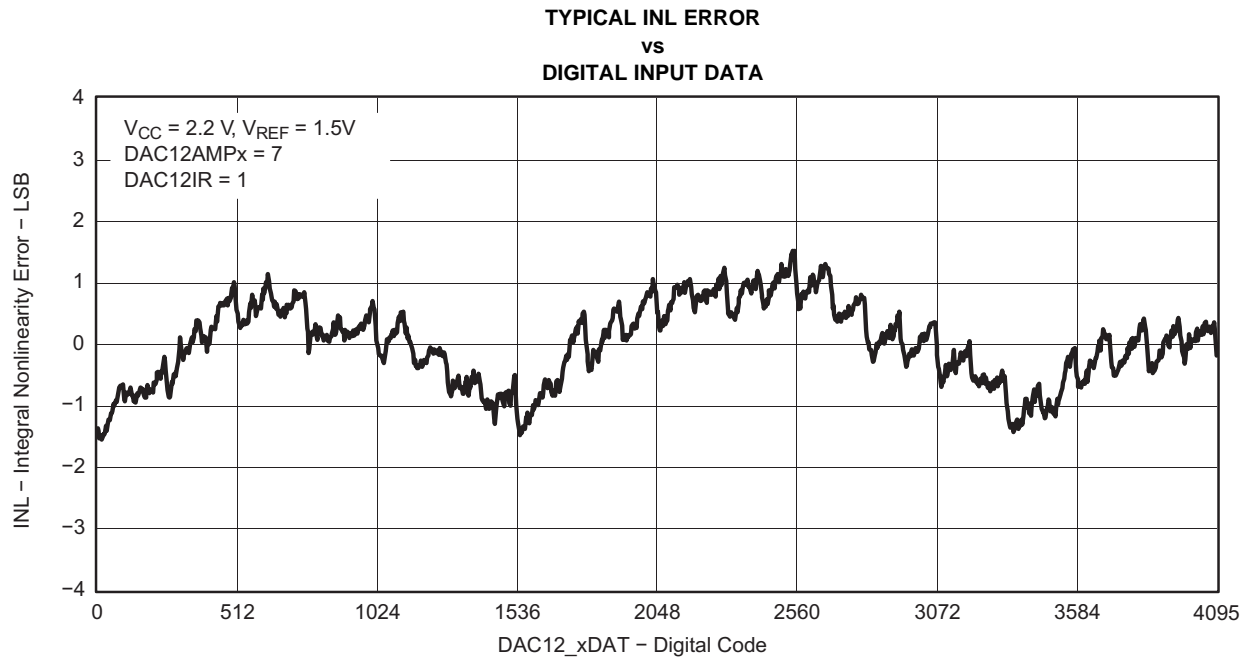

Figure 42.

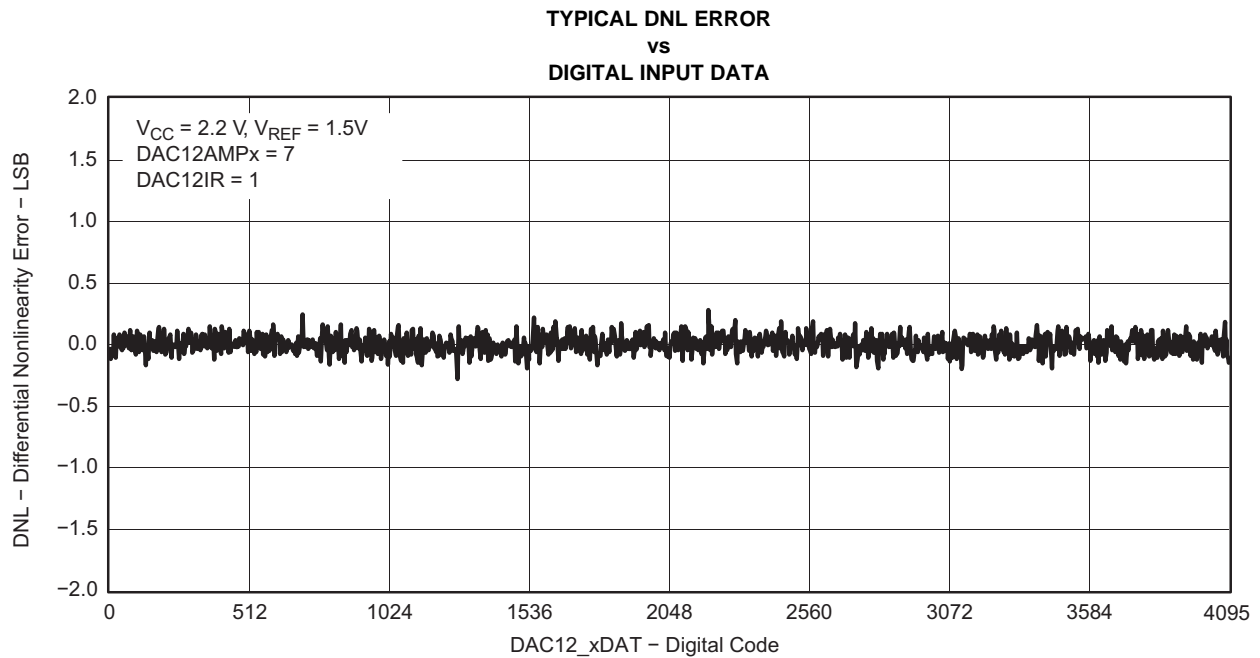

Figure 43.

12-Bit DAC Output Specifications

over recommended ranges of supply voltage and operating free-air temperature (unless otherwise noted)

PARAMETER	TEST CONDITIONS	V _{CC}	MIN	TYP	MAX	UNIT		
V _O	No Load, V _{eREF+} = AV _{CC} , DAC12_xDAT = 0h, DAC12IR = 1, DAC12AMPx = 7	2.2 V, 3 V	0		0.005	V		
	No Load, V _{eREF+} = AV _{CC} , DAC12_xDAT = 0FFh, DAC12IR = 1, DAC12AMPx = 7		AV _{CC} - 0.05		AV _{CC}			
	R _{Load} = 3 kΩ, V _{eREF+} = AV _{CC} , DAC12_xDAT = 0h, DAC12IR = 1, DAC12AMPx = 7		0		0.1			
	R _{Load} = 3 kΩ, V _{eREF+} = AV _{CC} , DAC12_xDAT = 0FFh, DAC12IR = 1, DAC12AMPx = 7		AV _{CC} - 0.13		AV _{CC}			
C _{L(DAC12)}	Maximum DAC12 load capacitance	2.2 V, 3 V			100	pF		
I _{L(DAC12)}	Maximum DAC12 load current	2.2 V	-0.5		0.5	mA		
		3 V	-1		1			
R _{O/P(DAC12)}	Output resistance (see Figure 44)	2.2 V, 3 V			150	250	Ω	
			R _{Load} = 3 kΩ, V _{O/P(DAC12)} = 0 V, DAC12AMPx = 7, DAC12_xDAT = 0h			150		250
			R _{Load} = 3 kΩ, V _{O/P(DAC12)} = AV _{CC} , DAC12AMPx = 7, DAC12_xDAT = 0FFh			1		4

(1) Data is valid after the offset calibration of the output amplifier.

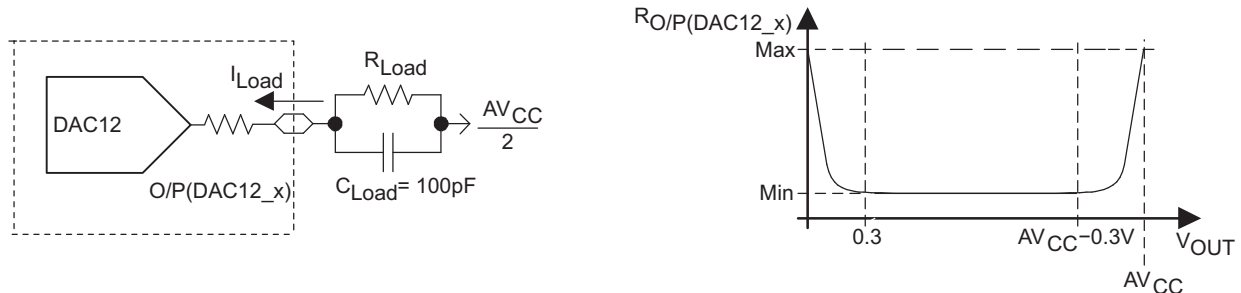

Figure 44. DAC12_x Output Resistance Tests

12-Bit DAC Reference Input Specifications

over recommended ranges of supply voltage and operating free-air temperature (unless otherwise noted)

PARAMETER	TEST CONDITIONS	V _{CC}	MIN	TYP	MAX	UNIT
V _{eREF+}	DAC12IR = 0 ⁽¹⁾⁽²⁾	2.2 V, 3 V		AV _{CC} / 3	AV _{CC} + 0.2	V
	DAC12IR = 1 ⁽³⁾⁽⁴⁾			AV _{CC}	AV _{CC} + 0.2	
R _{i(VREF+)} , R _{i(VeREF+)}	DAC12_0 IR = DAC12_1 IR = 0	2.2 V, 3 V	20			MΩ
	DAC12_0 IR = 1, DAC12_1 IR = 0		40	48	56	kΩ
	DAC12_0 IR = 0, DAC12_1 IR = 1		40	48	56	
	DAC12_0 IR = DAC12_1 IR = 1, DAC12_0 SREFx = DAC12_1 SREFx ⁽⁵⁾		20	24	28	

(1) For a full-scale output, the reference input voltage can be as high as 1/3 of the maximum output voltage swing (AV_{CC}).

(2) The maximum voltage applied at reference input voltage terminal V_{eREF+} = [AV_{CC} - V_{E(O)}] / [3 × (1 + E_G)].

(3) For a full-scale output, the reference input voltage can be as high as the maximum output voltage swing (AV_{CC}).

(4) The maximum voltage applied at reference input voltage terminal V_{eREF+} = [AV_{CC} - V_{E(O)}] / (1 + E_G).

(5) When DAC12IR = 1 and DAC12SREFx = 0 or 1 for both channels, the reference input resistive dividers for each DAC are in parallel reducing the reference input resistance.

12-Bit DAC Dynamic Specifications

$V_{REF} = V_{CC}$, DAC12IR = 1 (see Figure 45 and Figure 46), over recommended ranges of supply voltage and operating free-air temperature (unless otherwise noted)

PARAMETER		TEST CONDITIONS	V_{CC}	MIN	TYP	MAX	UNIT	
t_{ON}	DAC12 on-time	DAC12_xDAT = 800h, Error $_{V(O)}$ < ± 0.5 LSB ⁽¹⁾ (see Figure 45)	DAC12AMPx = 0 → {2, 3, 4}	2.2 V, 3 V	60	120	μ s	
					DAC12AMPx = 0 → {5, 6}	15		30
						DAC12AMPx = 0 → 7		6
$t_{S(FS)}$	Settling time, full scale	DAC12_xDAT = 80h → F7Fh → 80h	DAC12AMPx = 2	2.2 V, 3 V	100	200	μ s	
					DAC12AMPx = 3, 5	40		80
						DAC12AMPx = 4, 6, 7		15
$t_{S(C-C)}$	Settling time, code to code	DAC12_xDAT = 3F8h → 408h → 3F8h BF8h → C08h → BF8h	DAC12AMPx = 2	2.2 V, 3 V	5	μ s		
					DAC12AMPx = 3, 5		2	
							DAC12AMPx = 4, 6, 7	1
SR	Slew rate ⁽²⁾	DAC12_xDAT = 80h → F7Fh → 80h	DAC12AMPx = 2	2.2 V, 3 V	0.05	0.12	V/ μ s	
					DAC12AMPx = 3, 5	0.35		0.7
						DAC12AMPx = 4, 6, 7		1.5
	Glitch energy, full scale	DAC12_xDAT = 80h → F7Fh → 80h	DAC12AMPx = 2	2.2 V, 3 V	600	nV-s		
					DAC12AMPx = 3, 5		150	
							DAC12AMPx = 4, 6, 7	30
BW _{-3dB}	3-dB bandwidth, $V_{DC} = 1.5$ V, $V_{AC} = 0.1$ V _{PP} (see Figure 47)	DAC12AMPx = {2, 3, 4}, DAC12SREFx = 2, DAC12IR = 1, DAC12_xDAT = 800h	2.2 V, 3 V	40	kHz			
				DAC12AMPx = {5, 6}, DAC12SREFx = 2, DAC12IR = 1, DAC12_xDAT = 800h		180		
						DAC12AMPx = 7, DAC12SREFx = 2, DAC12IR = 1, DAC12_xDAT = 800h	550	
	Channel-to-channel crosstalk ⁽¹⁾ (see Figure 48)	DAC12_0DAT = 800h, No load, DAC12_1DAT = 80h ↔ F7Fh, $R_{Load} = 3$ k Ω , $f_{DAC12_1OUT} = 10$ kHz, Duty cycle = 50%	2.2 V, 3 V	-80	dB			
				DAC12_0DAT = 80h ↔ F7Fh, $R_{Load} = 3$ k Ω , DAC12_1DAT = 800h, No load, $f_{DAC12_0OUT} = 10$ kHz, Duty cycle = 50%		-80		

(1) R_{Load} and C_{Load} are connected to AV_{SS} (not $AV_{CC}/2$) in Figure 45.

(2) Slew rate applies to output voltage steps ≥ 200 mV.

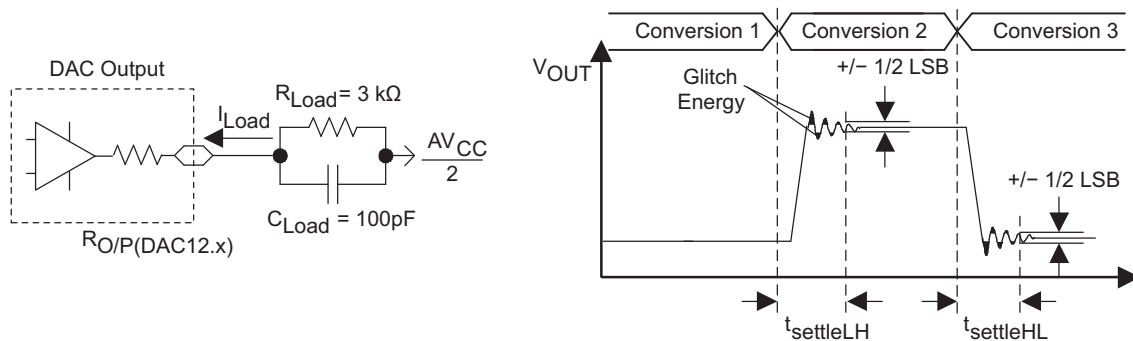

Figure 45. Settling Time and Glitch Energy Testing

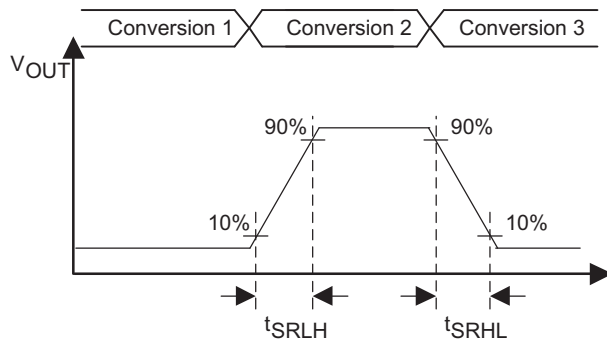

Figure 46. Slew Rate Testing

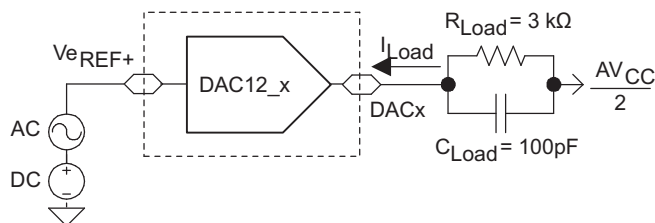

Figure 47. Test Conditions for 3-dB Bandwidth Specification

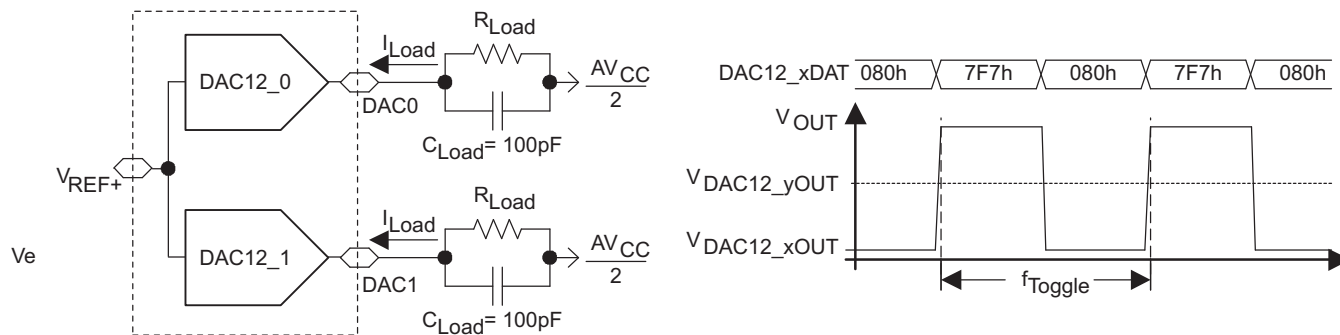

Figure 48. Crosstalk Test Conditions

Flash Memory

over recommended ranges of supply voltage and operating free-air temperature (unless otherwise noted)

PARAMETER		TEST CONDITIONS	V _{CC}	MIN	TYP	MAX	UNIT
V _{CC(PGM/ERASE)}	Program and erase supply voltage			2.2		3.6	V
f _{FTG}	Flash timing generator frequency			257		476	kHz
I _{PGM}	Supply current from V _{CC} during program		2.2 V/3.6 V		1	5	mA
I _{ERASE}	Supply current from V _{CC} during erase		2.2 V/3.6 V		1	7	mA
t _{CPT}	Cumulative program time ⁽¹⁾		2.2 V/3.6 V			10	ms
t _{CMErase}	Cumulative mass erase time		2.2 V/3.6 V	20			ms
	Program and erase endurance			10 ⁴	10 ⁵		cycles
t _{Retention}	Data retention duration	T _J = 25°C		100			years
t _{Word}	Word or byte program time	⁽²⁾			30		t _{FTG}
t _{Block, 0}	Block program time for first byte or word	⁽²⁾			25		t _{FTG}
t _{Block, 1-63}	Block program time for each additional byte or word	⁽²⁾			18		t _{FTG}
t _{Block, End}	Block program end-sequence wait time	⁽²⁾			6		t _{FTG}
t _{Mass Erase}	Mass erase time	⁽²⁾			10593		t _{FTG}
t _{Seg Erase}	Segment erase time	⁽²⁾			4819		t _{FTG}

- (1) The cumulative program time must not be exceeded when writing to a 64-byte flash block. This parameter applies to all programming methods: individual word/byte write and block write modes.
 (2) These values are hardwired into the Flash Controller's state machine (t_{FTG} = 1/f_{FTG}).

RAM

over recommended ranges of supply voltage and operating free-air temperature (unless otherwise noted)

PARAMETER		TEST CONDITIONS	MIN	MAX	UNIT
V _(RAMh)	RAM retention supply voltage ⁽¹⁾	CPU halted	1.6		V

- (1) This parameter defines the minimum supply voltage V_{CC} when the data in RAM remains unchanged. No program execution should happen during this supply voltage condition.

JTAG Interface

over recommended ranges of supply voltage and operating free-air temperature (unless otherwise noted)

PARAMETER		V _{CC}	MIN	TYP	MAX	UNIT
f _{TCK}	TCK input frequency ⁽¹⁾	2.2 V	0		5	MHz
		3 V	0		10	
R _{Internal}	Internal pullup resistance on TMS, TCK, and TDI/TCLK ⁽²⁾	2.2 V, 3 V	25	60	90	kΩ

- (1) f_{TCK} may be restricted to meet the timing requirements of the module selected.
 (2) TMS, TCK, and TDI/TCLK pullup resistors are implemented in all versions.

JTAG Fuse⁽¹⁾

over recommended ranges of supply voltage and operating free-air temperature (unless otherwise noted)

PARAMETER		TEST CONDITIONS	MIN	MAX	UNIT
V _{CC(FB)}	Supply voltage during fuse-blow condition	T _A = 25°C	2.5		V
V _{FB}	Voltage level on TEST for fuse blow		6	7	V
I _{FB}	Supply current into TEST during fuse blow			100	mA
t _{FB}	Time to blow fuse			1	ms

- (1) Once the fuse is blown, no further access to the JTAG/Test and emulation feature is possible, and JTAG is switched to bypass mode.

APPLICATION INFORMATION

Port P1 (P1.0 to P1.7), Input/Output With Schmitt Trigger

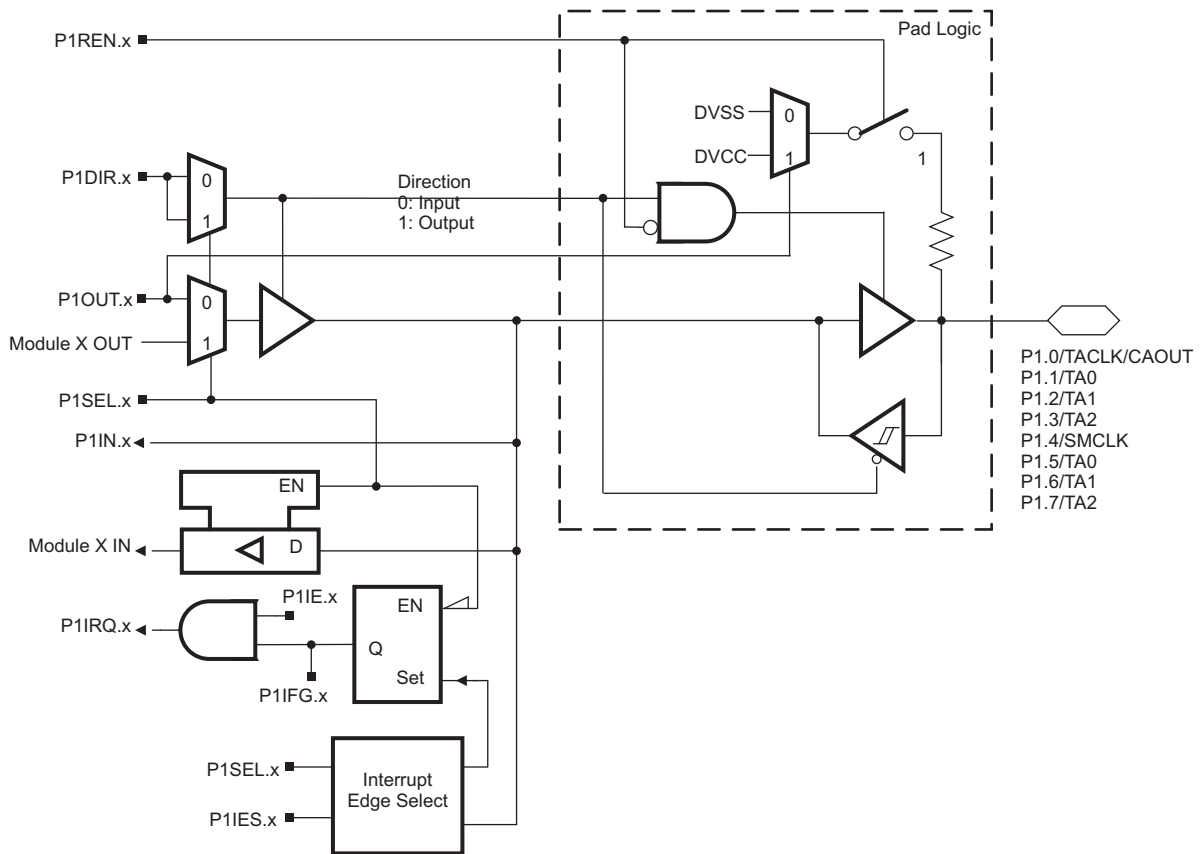

Table 15. Port P1 (P1.0 to P1.7) Pin Functions

PIN NAME (P1.x)	x	FUNCTION	CONTROL BITS / SIGNALS	
			P1DIR.x	P1SEL.x
P1.0/TACLK/CAOUT	0	P1.0 (I/O)	I: 0; O: 1	0
		Timer_A3.TACLK	0	1
		CAOUT	1	1
P1.1/TA0	1	P1.1 (I/O)	I: 0; O: 1	0
		Timer_A3.CCI0A	0	1
		Timer_A3.TA0	1	1
P1.2/TA1	2	P1.2 (I/O)	I: 0; O: 1	0
		Timer_A3.CCI1A	0	1
		Timer_A3.TA1	1	1
P1.3/TA2	3	P1.3 (I/O)	I: 0; O: 1	0
		Timer_A3.CCI2A	0	1
		Timer_A3.TA2	1	1
P1.4/SMCLK	4	P1.4 (I/O)	I: 0; O: 1	0
		SMCLK	1	1
P1.5/TA0	5	P1.5 (I/O)	I: 0; O: 1	0
		Timer_A3.TA0	1	1
P1.6/TA1	6	P1.6 (I/O)	I: 0; O: 1	0
		Timer_A3.TA1	1	1
P1.7/TA2	7	P1.7 (I/O)	I: 0; O: 1	0
		Timer_A3.TA2	1	1

Port P2 (P2.0 to P2.4, P2.6, and P2.7), Input/Output With Schmitt Trigger

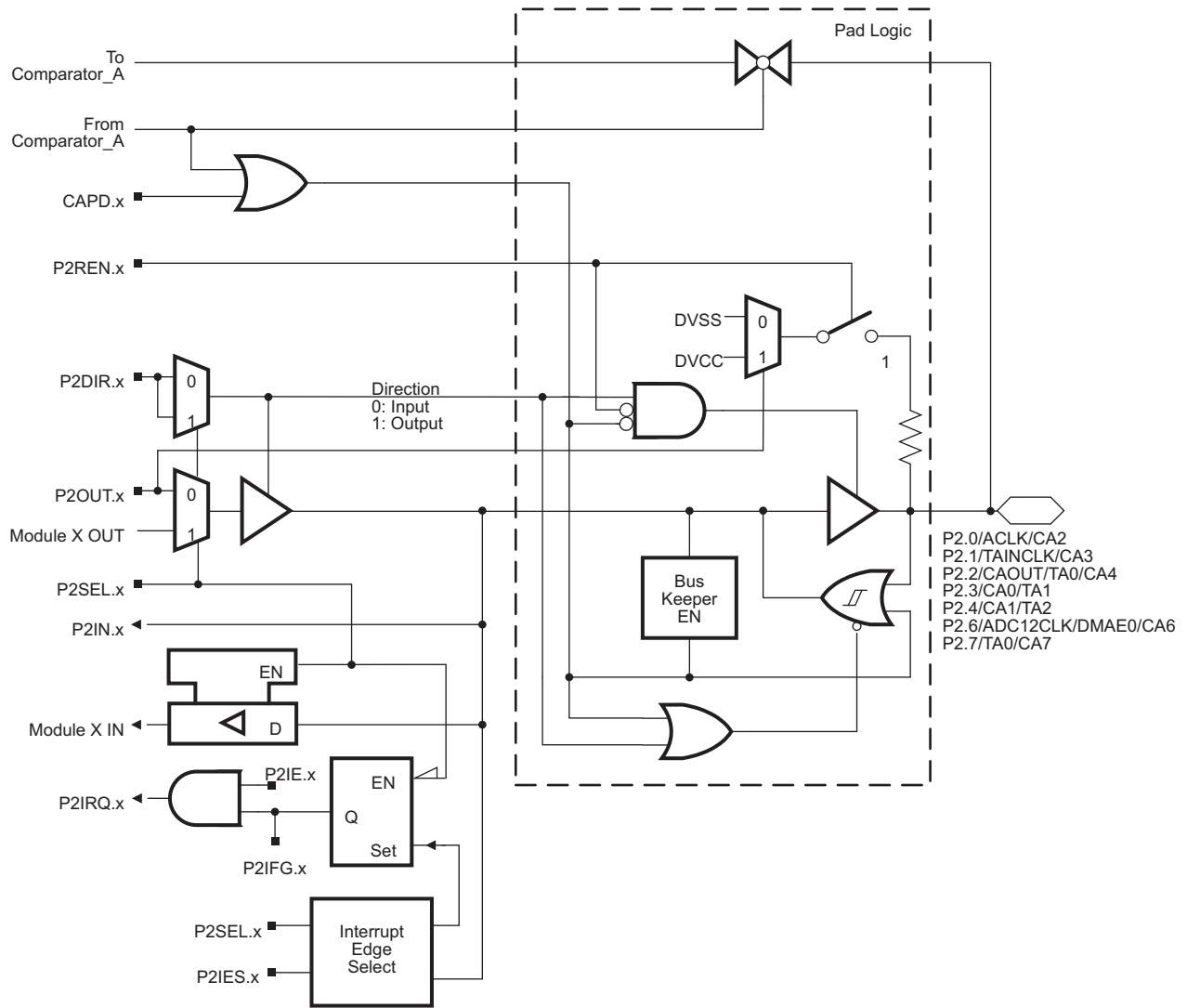

Table 16. Port P2 (P2.0 to P2.4, P2.6, and P2.7) Pin Functions

PIN NAME (P2.x)	x	FUNCTION	CONTROL BITS / SIGNALS ⁽¹⁾		
			CAPD.x	P2DIR.x	P2SEL.x
P2.0/ACLK/CA2	0	P2.0 (I/O)	0	I: 0; O: 1	0
		ACLK	0	1	1
		CA2	1	X	X
P2.1/TAINCLK/CA3	1	P2.1 (I/O)	0	I: 0; O: 1	0
		Timer_A3.INCLK	0	0	1
		DV _{SS}	0	1	1
		CA3	1	X	X
P2.2/CAOUT/TA0/CA4	2	P2.2 (I/O)	0	I: 0; O: 1	0
		CAOUT	0	1	1
		Timer_A3.CCI0B	0	0	1
		CA4	1	X	X
P2.3/CA0/TA1	3	P2.3 (I/O)	0	I: 0; O: 1	0
		Timer_A3.TA1	0	1	1
		CA0	1	X	X
P2.4/CA1/TA2	4	P2.4 (I/O)	0	I: 0; O: 1	0
		Timer_A3.TA2	0	1	X
		CA1	1	X	1
P2.6/ADC12CLK/ DMAE0 ⁽²⁾ /CA6	6	P2.6 (I/O)	0	I: 0; O: 1	0
		ADC12CLK	0	1	1
		DMAE0	0	0	1
		CA6	1	X	X
P2.7/TA0/CA7	7	P2.7 (I/O)	0	I: 0; O: 1	0
		Timer_A3.TA0	0	1	1
		CA7	1	X	X

- (1) X = Don't care
- (2) MSP430F261x devices only

Port P2 (P2.5), Input/Output With Schmitt Trigger

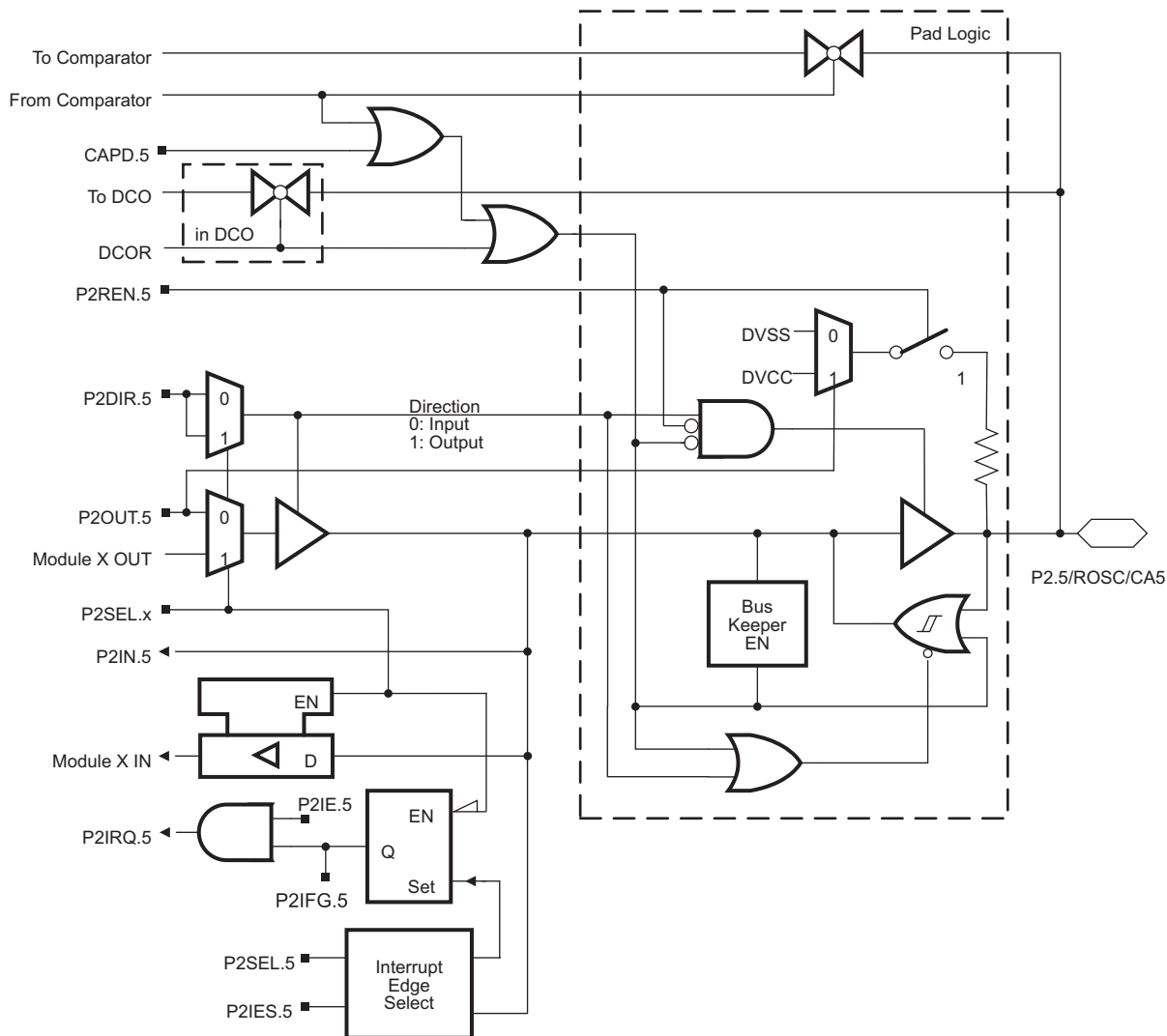

Table 17. Port P2 (P2.5) Pin Functions

PIN NAME (P2.x)	x	FUNCTION	CONTROL BITS / SIGNALS ⁽¹⁾			
			CAPD	DCOR	P2DIR.5	P2SEL.5
P2.5/R _{OSC} /CA5	5	P2.5 (I/O)	0	0	I: 0; O: 1	0
		R _{OSC} ⁽²⁾	0	1	X	X
		DV _{SS}	0	0	1	1
		CA5	1 or selected	0	X	X

(1) X = Don't care

(2) If R_{OSC} is used, it is connected to an external resistor.

Port P3 (P3.0 to P3.7), Input/Output With Schmitt Trigger

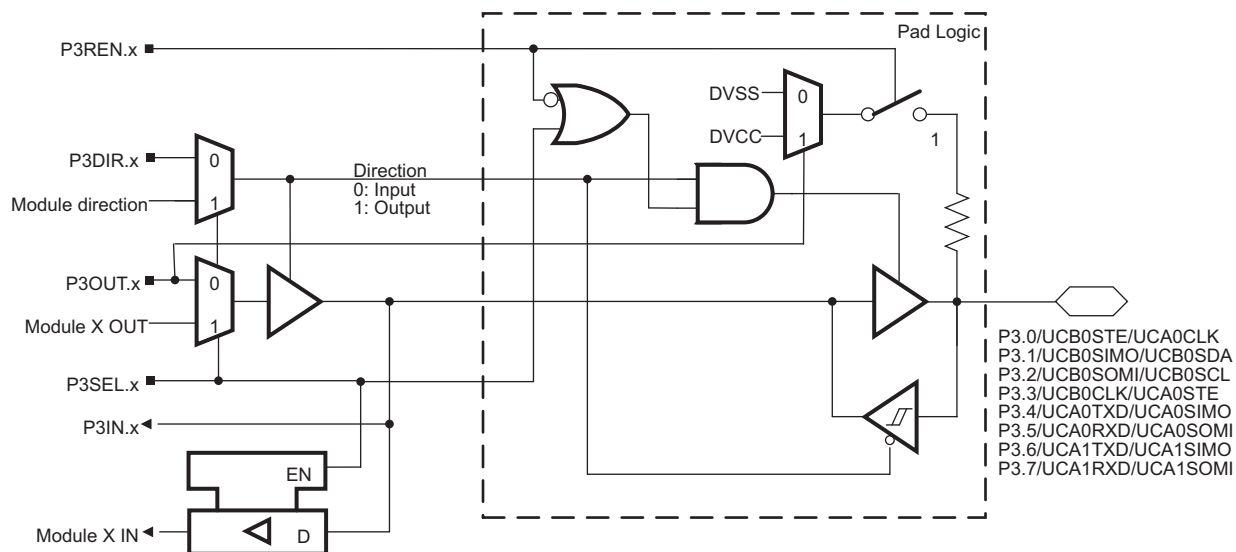

Table 18. Port P3 (P3.0 to P3.7) Pin Functions

PIN NAME (P3.x)	x	FUNCTION	CONTROL BITS / SIGNALS ⁽¹⁾	
			P3DIR.x	P3SEL.x
P3.0/UCB0STE/ UCA0CLK	0	P3.0 (I/O)	I: 0; O: 1	0
		UCB0STE/UCA0CLK ⁽²⁾⁽³⁾	X	1
P3.1/UCB0SIMO/ UCB0SDA	1	P3.1 (I/O)	I: 0; O: 1	0
		UCB0SIMO/UCB0SDA ⁽⁴⁾⁽⁵⁾	X	1
P3.2/UCB0SOMI/ UCB0SCL	2	P3.2 (I/O)	I: 0; O: 1	0
		UCB0SOMI/UCB0SCL ⁽⁴⁾⁽⁵⁾	X	1
P3.3/UCB0CLK/ UCA0STE	3	P3.3 (I/O)	I: 0; O: 1	0
		UCB0CLK/UCA0STE ⁽⁴⁾	X	1
P3.4/UCA0TXD/ UCA0SIMO	4	P3.4 (I/O)	I: 0; O: 1	0
		UCA0TXD/UCA0SIMO ⁽⁴⁾	X	1
P3.5/UCA0RXD/ UCA0SOMI	5	P3.5 (I/O)	I: 0; O: 1	0
		UCA0RXD/UCA0SOMI ⁽⁴⁾	X	1
P3.6/UCA1TXD/ UCA1SIMO	6	P3.6 (I/O)	I: 0; O: 1	0
		UCA1TXD/UCA1SIMO ⁽⁴⁾	X	1
P3.7/UCA1RXD/ UCA1SOMI	7	P3.7 (I/O)	I: 0; O: 1	0
		UCA1RXD/UCA1SOMI ⁽⁴⁾	X	1

(1) X = Don't care

(2) The pin direction is controlled by the USCI module.

(3) UCA0CLK function takes precedence over UCB0STE function. If the pin is required as UCA0CLK input or output, USCI_A0/B0 is forced to 3-wire SPI mode if 4-wire SPI mode is selected.

(4) The pin direction is controlled by the USCI module.

(5) If the I2C functionality is selected, the output drives only the logical 0 to V_{SS} level.

Port P4 (P4.0 to P4.7), Input/Output With Schmitt Trigger

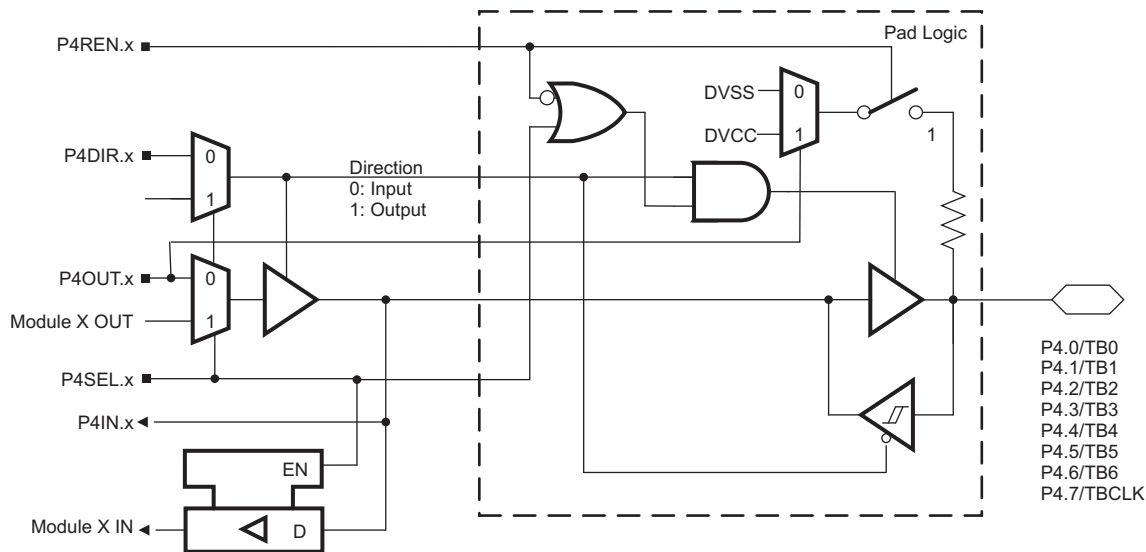

Table 19. Port P4 (P4.0 to P4.7) Pin Functions

PIN NAME (P4.x)	x	FUNCTION	CONTROL BITS / SIGNALS ⁽¹⁾	
			P4DIR.x	P4SEL.x
P4.0/TB0	0	P4.0 (I/O)	I: 0; O: 1	0
		Timer_B7.CCI0A and Timer_B7.CCI0B	0	1
		Timer_B7.TB0	1	1
P4.1/TB1	1	P4.1 (I/O)	I: 0; O: 1	0
		Timer_B7.CCI1A and Timer_B7.CCI1B	0	1
		Timer_B7.TB1	1	1
P4.2/TB2	2	P4.2 (I/O)	I: 0; O: 1	0
		Timer_B7.CCI2A and Timer_B7.CCI2B	0	1
		Timer_B7.TB2	1	1
P4.3/TB3	3	P4.3 (I/O)	I: 0; O: 1	0
		Timer_B7.CCI3A and Timer_B7.CCI3B	0	1
		Timer_B7.TB3	1	1
P4.4/TB4	4	P4.4 (I/O)	I: 0; O: 1	0
		Timer_B7.CCI4A and Timer_B7.CCI4B	0	1
		Timer_B7.TB4	1	1
P4.5/TB5	5	P4.5 (I/O)	I: 0; O: 1	0
		Timer_B7.CCI5A and Timer_B7.CCI5B	0	1
		Timer_B7.TB5	1	1
P4.6/TB6	6	P4.6 (I/O)	I: 0; O: 1	0
		Timer_B7.CCI6A and Timer_B7.CCI6B	0	1
		Timer_B7.TB6	1	1
P4.7/TBCLK	7	P4.7 (I/O)	I: 0; O: 1	0
		Timer_B7.TBCLK	1	1

(1) X = Don't care

Port P5 (P5.0 to P5.7), Input/Output With Schmitt Trigger

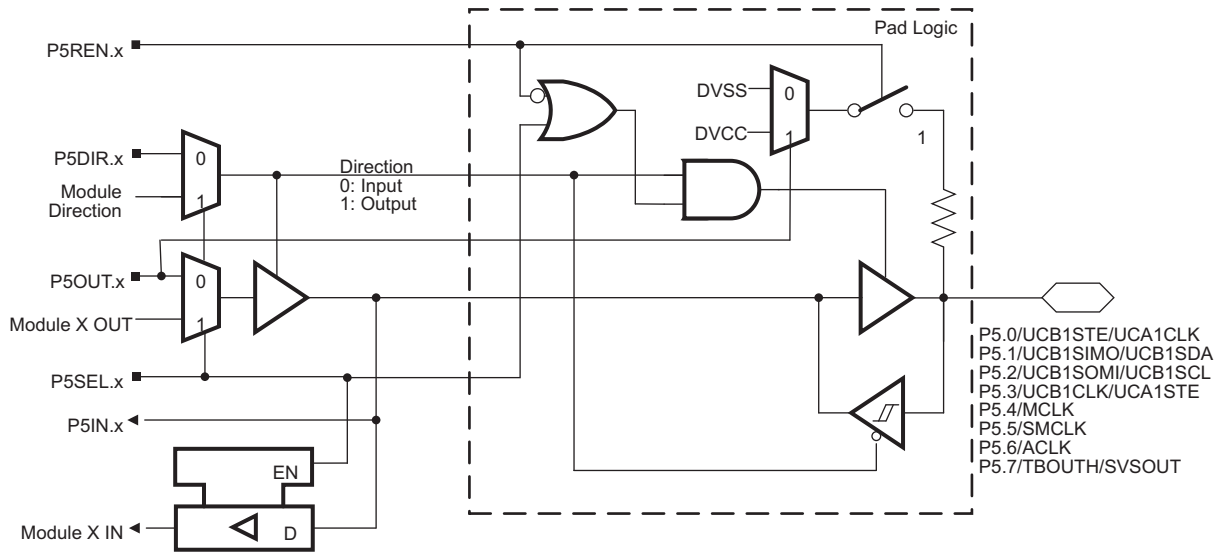

Table 20. Port P5 (P5.0 to P5.7) Pin Functions

PIN NAME (P5.x)	x	FUNCTION	CONTROL BITS / SIGNALS ⁽¹⁾	
			P5DIR.x	P5SEL.x
P5.0/UCB1STE/ UCA1CLK	0	P5.0 (I/O)	I: 0; O: 1	0
		UCB1STE/UCA1CLK ⁽²⁾⁽³⁾	X	1
P5.1/UCB1SIMO/ UCB1SDA	1	P5.1 (I/O)	I: 0; O: 1	0
		UCB1SIMO/UCB1SDA ⁽²⁾⁽⁴⁾	X	1
P5.2/UCB1SOMI/ UCB1SCL	2	P5.2 (I/O)	I: 0; O: 1	0
		UCB1SOMI/UCB1SCL ⁽²⁾⁽⁴⁾	X	1
P5.3/UCB1CLK/ UCA1STE	3	P5.3 (I/O)	I: 0; O: 1	0
		UCB1CLK/UCA1STE ⁽²⁾	X	1
P5.4/MCLK	4	P5.4 (I/O)	I: 0; O: 1	0
		MCLK	1	1
P5.5/SMCLK	5	P5.5 (I/O)	I: 0; O: 1	0
		SMCLK	1	1
P5.6/ACLK	6	P5.6 (I/O)	I: 0; O: 1	0
		ACLK	1	1
P5.7/TBOUTH/SVSOUT	7	P5.7 (I/O)	I: 0; O: 1	0
		TBOUTH	0	1
		SVSOUT	1	1

(1) X = Don't care

(2) The pin direction is controlled by the USCI module.

(3) UCA1CLK function takes precedence over UCB1STE function. If the pin is required as UCA1CLK input or output USCI_A1/B1 will be forced to 3-wire SPI mode if 4-wire SPI mode is selected.

(4) If the I2C functionality is selected, the output drives only the logical 0 to V_{SS} level.

Port P6 (P6.0 to P6.4), Input/Output With Schmitt Trigger

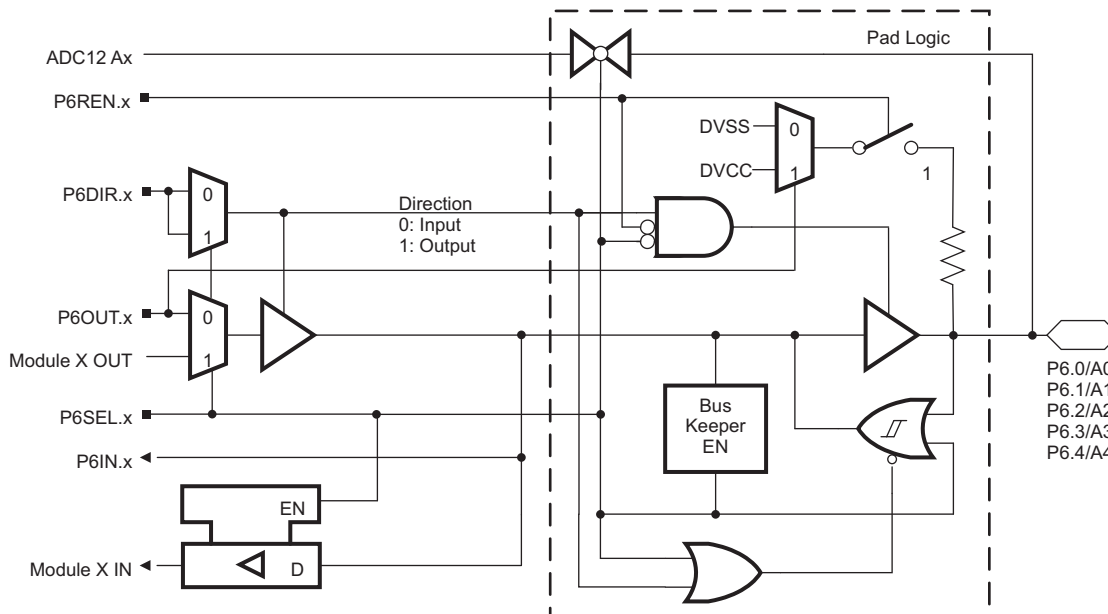

Table 21. Port P6 (P6.0 to P6.4) Pin Functions

PIN NAME (P6.x)	x	FUNCTION	CONTROL BITS / SIGNALS ⁽¹⁾		
			P6DIR.x	P6SEL.x	INCH.x
P6.0/A0	0	P6.0 (I/O)	I: 0; O: 1	0	0
		A0 ⁽²⁾	X	1	1 (y = 0)
P6.1/A1	1	P6.1 (I/O)	I: 0; O: 1	0	0
		A1 ⁽²⁾	X	1	1 (y = 1)
P6.2/A2	2	P6.2 (I/O)	I: 0; O: 1	0	0
		A2 ⁽²⁾	X	1	1 (y = 2)
P6.3/A3	3	P6.3 (I/O)	I: 0; O: 1	0	0
		A3 ⁽²⁾	X	1	1 (y = 3)
P6.4/A4	4	P6.4 (I/O)	I: 0; O: 1	0	0
		A4 ⁽²⁾	X	1	1 (y = 4)

(1) X = Don't care

(2) The ADC12 channel Ax is connected to AV_{SS} internally if not selected.

Port P6 (P6.7), Input/Output With Schmitt Trigger

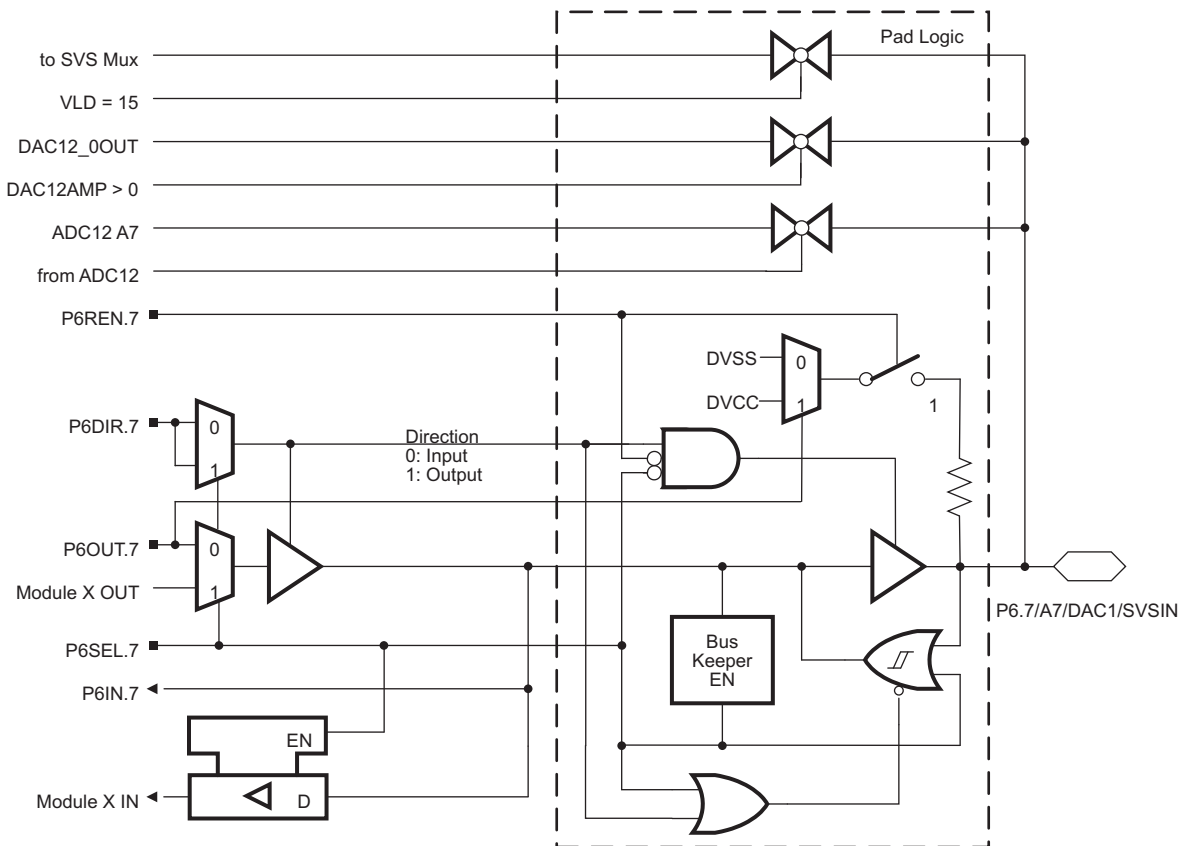

Table 23. Port P6 (P6.7) Pin Functions

PIN NAME (P6.x)	x	FUNCTION	CONTROL BITS / SIGNALS ⁽¹⁾			
			P6DIR.x	P6SEL.x	INCH.y	DAC12AMP>0
P6.7/A7/DAC1 ⁽²⁾ / SVSIN ⁽²⁾	7	P6.7 (I/O)	I: 0; O: 1	0	0	0
		DV _{SS}	1	1	0	0
		A7 ⁽³⁾	X	1	1 (y = 7)	0
		DAC1 (DAC12OPS = 0) ⁽⁴⁾	X	1	0	1
		SVSIN (VLD = 15)	X	1	0	0

- (1) X = Don't care
- (2) MSP430F261x devices only
- (3) The ADC12 channel Ax is connected to AV_{SS} internally if not selected.
- (4) The DAC outputs are floating if not selected.

Port P7 (P7.0 to P7.7), Input/Output With Schmitt Trigger⁽⁵⁾

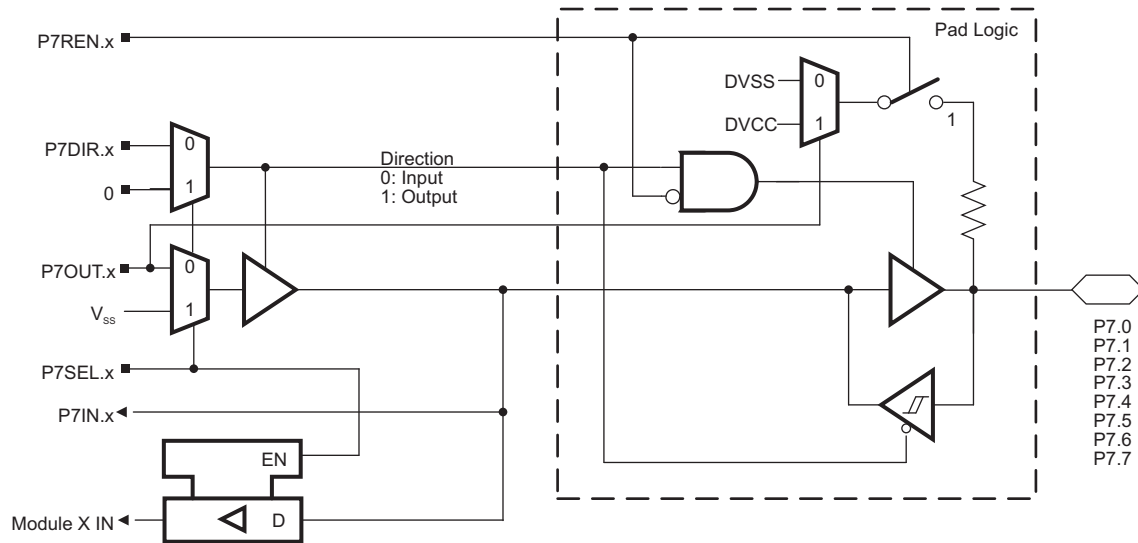

Table 24. Port P7 (P7.0 to P7.7) Pin Functions⁽¹⁾

PIN NAME (P7.x)	x	FUNCTION	CONTROL BITS / SIGNALS ⁽²⁾	
			P7DIR.x	P7SEL.x
P7.0	0	P7.0 (I/O)	I: 0; O: 1	0
		Input	X	1
P7.1	1	P7.1 (I/O)	I: 0; O: 1	0
		Input	X	1
P7.2	2	P7.2 (I/O)	I: 0; O: 1	0
		Input	X	1
P7.3	3	P7.3 (I/O)	I: 0; O: 1	0
		Input	X	1
P7.4	4	P7.4 (I/O)	I: 0; O: 1	0
		Input	X	1
P7.5	5	P7.5 (I/O)	I: 0; O: 1	0
		Input	X	1
P7.6	6	P7.6 (I/O)	I: 0; O: 1	0
		Input	X	1
P7.7	7	P7.7 (I/O)	I: 0; O: 1	0
		Input	X	1

(5) 80-pin devices only

(1) 80-pin devices only

(2) X = Don't care

Port P8 (P8.0 to P8.5), Input/Output With Schmitt Trigger⁽³⁾

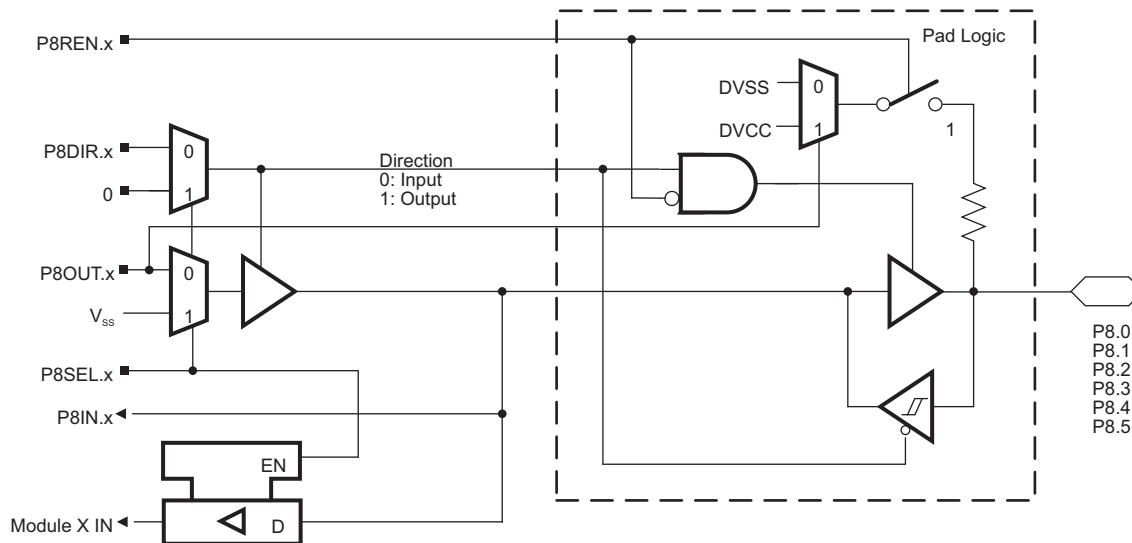

Table 25. Port P8 (P8.0 to P8.5) Pin Functions⁽¹⁾

PIN NAME (P8.x)	x	FUNCTION	CONTROL BITS / SIGNALS ⁽²⁾	
			P8DIR.x	P8SEL.x
P8.0	0	P8.0 (I/O)	I: 0; O: 1	0
		Input	X	1
P8.1	1	P8.1 (I/O)	I: 0; O: 1	0
		Input	X	1
P8.2	2	P8.2 (I/O)	I: 0; O: 1	0
		Input	X	1
P8.3	3	P8.3 (I/O)	I: 0; O: 1	0
		Input	X	1
P8.4	4	P8.4 (I/O)	I: 0; O: 1	0
		Input	X	1
P8.5	5	P8.5 (I/O)	I: 0; O: 1	0
		Input	X	1

(3) 80-pin devices only

(1) 80-pin devices only

(2) X = Don't care

Port P8 (P8.6), Input/Output With Schmitt Trigger⁽³⁾

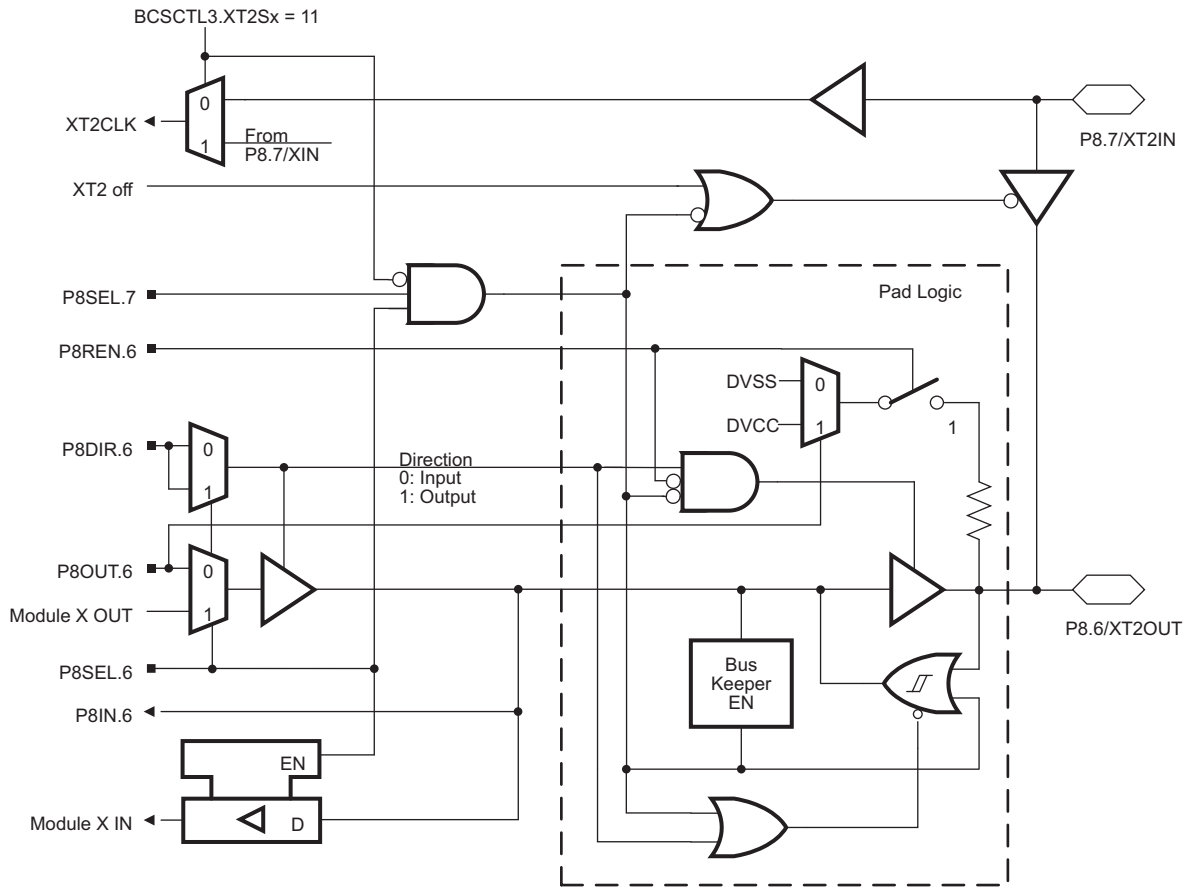

Table 26. Port P8 (P8.6) Pin Functions⁽¹⁾

PIN NAME (P8.x)	x	FUNCTION	CONTROL BITS / SIGNALS	
			P8DIR.x	P8SEL.x
P8.6/XT2OUT	6	P8.6 (I/O)	I: 0; O: 1	0
		XT2OUT (default)	0	1
		DV _{SS}	1	1

(3) 80-pin devices only

(1) 80-pin devices only

Port P8 (P8.7), Input/Output With Schmitt Trigger⁽²⁾

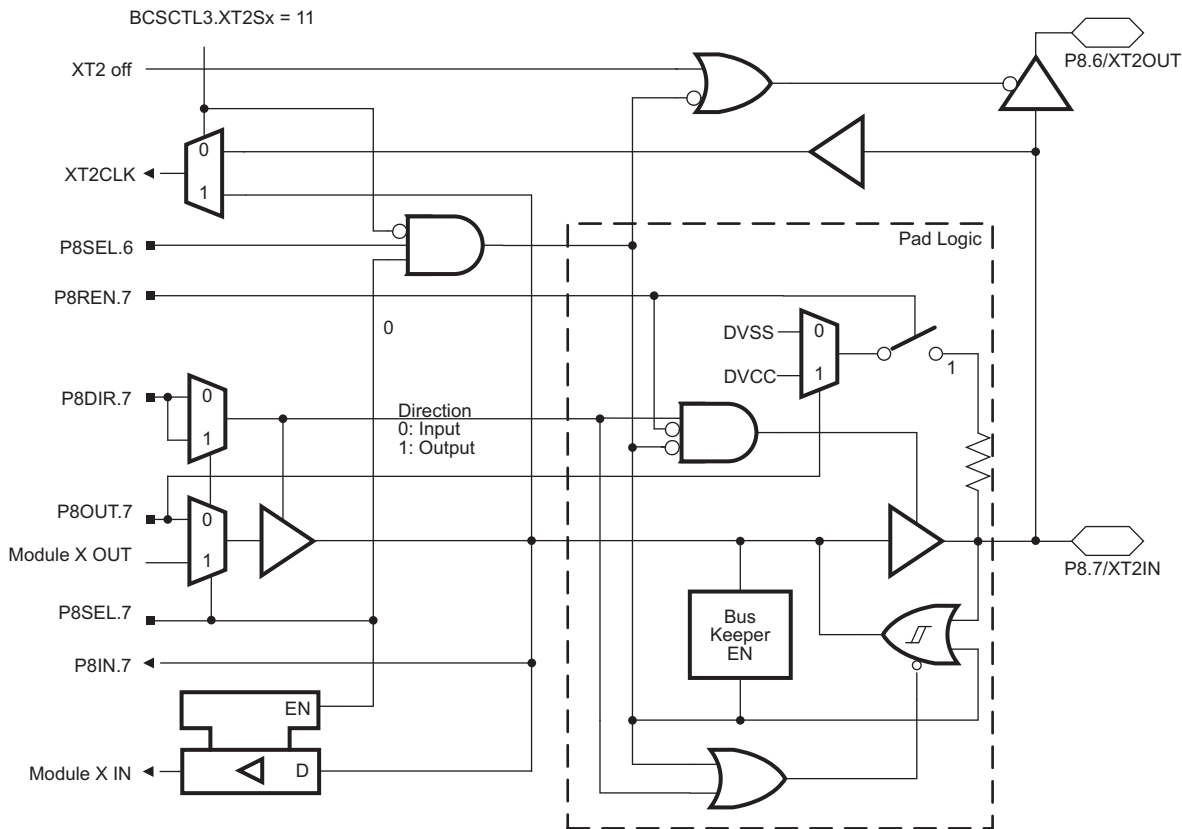

Table 27. Port P8 (P8.7) Pin Functions⁽¹⁾

PIN NAME (P8.x)	x	FUNCTION	CONTROL BITS / SIGNALS	
			P8DIR.x	P8SEL.x
P8.7/XT2IN	7	P8.7 (I/O)	I: 0; O: 1	0
		XT2IN (default)	0	1
		V _{SS}	1	1

(2) 80-pin devices only

(1) 80-pin devices only

JTAG Pins: TMS, TCK, TDI/TCLK, TDO/TDI, Input/Output With Schmitt Trigger

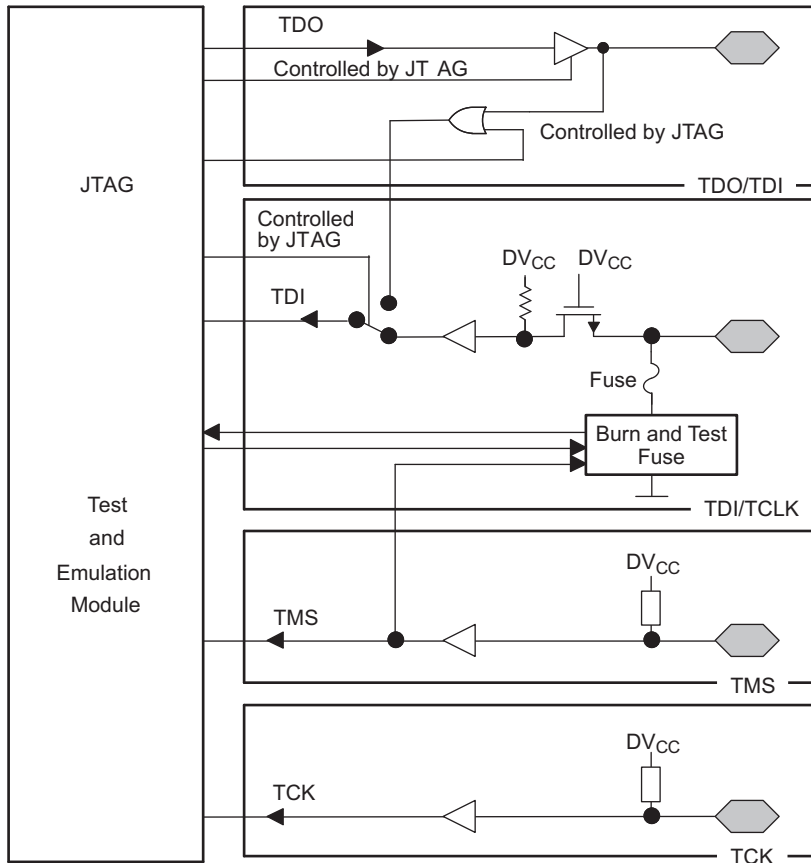

During Programming Activity and During Blowing of the Fuse, Pin TDO/TDI Is Used to Apply the Test Input Data for JTAG Circuitry

JTAG Fuse Check Mode

MSP430 devices that have the fuse on the TEST terminal have a fuse check mode that tests the continuity of the fuse the first time the JTAG port is accessed after a power-on reset (POR). When activated, a fuse check current, I_{TF} , of 1 mA at 3 V, 2.5 mA at 5 V can flow from the TEST pin to ground if the fuse is not burned. Care must be taken to avoid accidentally activating the fuse check mode and increasing overall system power consumption.

When the TEST pin is again taken low after a test or programming session, the fuse check mode and sense currents are terminated.

Activation of the fuse check mode occurs with the first negative edge on the TMS pin after power up or if TMS is being held low during power up. The second positive edge on the TMS pin deactivates the fuse check mode. After deactivation, the fuse check mode remains inactive until another POR occurs. After each POR the fuse check mode has the potential to be activated.

The fuse check current flows only when the fuse check mode is active and the TMS pin is in a low state (see [Figure 49](#)). Therefore, the additional current flow can be prevented by holding the TMS pin high (default condition).

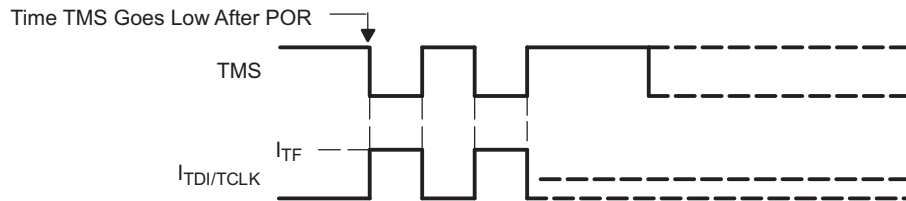

Figure 49. Fuse Check Mode Current

REVISION HISTORY

LITERATURE NUMBER	DESCRIPTION
SLAS541	Product Preview release
SLAS541A	Production Data release Corrected the format and the content shown on the first page. Corrected pin number of P3.6 and P3.7 in 64-pin package in the terminal function list. Corrected the port schematics. Corrected "calibration data" section (page 20). Typos and formatting corrected. Added the figure "typical characteristics - LPM4 current" (Page 33).
SLAS541B	Added preview of MSP430F261x BGA devices.
SLAS541C	Release to market of MSP430F261x BGA devices
SLAS541D	Added the ESD disclaimer (page 1). Added reserved BGA pins to the terminal function list (pages 10 and following). Corrected the references in the output port parameters (page 36). Corrected the cumulative program time of the flash (page 75).
SLAS541E	Corrected LFXT1Sx values in Figures 23 and 24 (page 52). Corrected XT2Sx values in Figures 25 and 26 (page 54). Corrected $t_{CMErase}$ MIN value from 200 ms to 20 ms and removed two notes in the flash memory table (page 75).
SLAS541F	Renamed Tags Used by the ADC Calibration Tags table to Tags used by the TLV Structure (page 20). Changed value of TAG_ADC12_1 from 0x10 to 0x08 in Tags used by the TLV Structure (page 20). Added CAOUT to P1.0/TACLK, Changed Timer_A3.CCI0A to Timer_A3.CCI1A and Timer_A3.TA0 to Timer_A3.TA1 in P1.2/TA1 row, Changed Timer_A3.CCI0A to Timer_A3.CCI2A and Timer_A3.TA0 to Timer_A3.TA2 in P1.3/TA2 row in Port P1 (P1.0 to P1.7) pin functions table (page 78). Changed TA0 to Timer_A3.CCI0B in P2.2/CAOUT/TA0/CA4 row of Port P2.0, P2.3, P2.4, P2.6 and P2.7 pin functions table (page 80).
SLAS541G	Changed limits on $t_{d(SV_{Son})}$ parameter (page 40)
SLAS541H	Changed Control Bits/Signals in Table 21 , Table 22 , and Table 23 . Changed crystal signal names in Table 26 and Table 27 .
SLAS541I	Changed T_{stg} , Programmed device, to -55°C to 150°C in Absolute Maximum Ratings .
SLAS541J	Added nonmagnetic package option to Description and Table 1 .
SLAS541K	Changed P8.6/XT2OUT and P8.7/XT2IN to I/O in Table 2 .

PACKAGING INFORMATION

Orderable Device	Status (1)	Package Type	Package Drawing	Pins	Package Qty	Eco Plan (2)	Lead/Ball Finish (6)	MSL Peak Temp (3)	Op Temp (°C)	Device Marking (4/5)	Samples
MSP430F2416TPM	ACTIVE	LQFP	PM	64	160	Green (RoHS & no Sb/Br)	CU NIPDAU	Level-3-260C-168 HR	-40 to 105	M430F2416T	Samples
MSP430F2416TPMR	ACTIVE	LQFP	PM	64	1000	Green (RoHS & no Sb/Br)	CU NIPDAU	Level-3-260C-168 HR	-40 to 105	M430F2416T	Samples
MSP430F2416TPN	ACTIVE	LQFP	PN	80	119	Green (RoHS & no Sb/Br)	CU NIPDAU	Level-3-260C-168 HR	-40 to 105	M430F2416T	Samples
MSP430F2416TPNR	ACTIVE	LQFP	PN	80	1000	Green (RoHS & no Sb/Br)	CU NIPDAU	Level-3-260C-168 HR	-40 to 105	M430F2416T	Samples
MSP430F2416TZQW	ACTIVE	BGA MICROSTAR JUNIOR	ZQW	113	260	Green (RoHS & no Sb/Br)	SNAGCU	Level-3-260C-168 HR	-40 to 105	M430F2416T	Samples
MSP430F2416TZQWR	ACTIVE	BGA MICROSTAR JUNIOR	ZQW	113	2500	Green (RoHS & no Sb/Br)	SNAGCU	Level-3-260C-168 HR	-40 to 105	M430F2416T	Samples
MSP430F2417TPM	ACTIVE	LQFP	PM	64	160	Green (RoHS & no Sb/Br)	CU NIPDAU	Level-3-260C-168 HR	-40 to 105	M430F2417T	Samples
MSP430F2417TPMR	ACTIVE	LQFP	PM	64	1000	Green (RoHS & no Sb/Br)	CU NIPDAU	Level-3-260C-168 HR	-40 to 105	M430F2417T	Samples
MSP430F2417TPN	ACTIVE	LQFP	PN	80	119	Green (RoHS & no Sb/Br)	CU NIPDAU	Level-3-260C-168 HR	-40 to 105	M430F2417T	Samples
MSP430F2417TPNR	ACTIVE	LQFP	PN	80	1000	Green (RoHS & no Sb/Br)	CU NIPDAU	Level-3-260C-168 HR	-40 to 105	M430F2417T	Samples
MSP430F2417TZQW	LIFEBUY	BGA MICROSTAR JUNIOR	ZQW	113	260	Green (RoHS & no Sb/Br)	SNAGCU	Level-3-260C-168 HR	0 to 0	M430F2417T	
MSP430F2417TZQWR	ACTIVE	BGA MICROSTAR JUNIOR	ZQW	113	2500	Green (RoHS & no Sb/Br)	SNAGCU	Level-3-260C-168 HR	-40 to 105	M430F2417T	Samples
MSP430F2418TPM	ACTIVE	LQFP	PM	64	160	Green (RoHS & no Sb/Br)	CU NIPDAU	Level-3-260C-168 HR	-40 to 105	M430F2418T	Samples
MSP430F2418TPMR	ACTIVE	LQFP	PM	64	1000	Green (RoHS & no Sb/Br)	CU NIPDAU	Level-3-260C-168 HR	-40 to 105	M430F2418T	Samples
MSP430F2418TPN	ACTIVE	LQFP	PN	80	119	Green (RoHS & no Sb/Br)	CU NIPDAU	Level-3-260C-168 HR	-40 to 105	M430F2418T	Samples

Orderable Device	Status (1)	Package Type	Package Drawing	Pins	Package Qty	Eco Plan (2)	Lead/Ball Finish (6)	MSL Peak Temp (3)	Op Temp (°C)	Device Marking (4/5)	Samples
MSP430F2418TPNR	ACTIVE	LQFP	PN	80	1000	Green (RoHS & no Sb/Br)	CU NIPDAU	Level-3-260C-168 HR	-40 to 105	M430F2418T	Samples
MSP430F2418TZQW	ACTIVE	BGA MICROSTAR JUNIOR	ZQW	113	260	Green (RoHS & no Sb/Br)	SNAGCU	Level-3-260C-168 HR	-40 to 105	M430F2418T	Samples
MSP430F2418TZQWR	ACTIVE	BGA MICROSTAR JUNIOR	ZQW	113	2500	Green (RoHS & no Sb/Br)	SNAGCU	Level-3-260C-168 HR	-40 to 105	M430F2418T	Samples
MSP430F2419TPM	ACTIVE	LQFP	PM	64	160	Green (RoHS & no Sb/Br)	CU NIPDAU	Level-3-260C-168 HR	-40 to 105	M430F2419T	Samples
MSP430F2419TPMR	ACTIVE	LQFP	PM	64	1000	Green (RoHS & no Sb/Br)	CU NIPDAU	Level-3-260C-168 HR	-40 to 105	M430F2419T	Samples
MSP430F2419TPN	ACTIVE	LQFP	PN	80	119	Green (RoHS & no Sb/Br)	CU NIPDAU	Level-3-260C-168 HR	-40 to 105	M430F2419T	Samples
MSP430F2419TPNR	ACTIVE	LQFP	PN	80	1000	Green (RoHS & no Sb/Br)	CU NIPDAU	Level-3-260C-168 HR	-40 to 105	M430F2419T	Samples
MSP430F2419TZQW	ACTIVE	BGA MICROSTAR JUNIOR	ZQW	113	260	Green (RoHS & no Sb/Br)	SNAGCU	Level-3-260C-168 HR	-40 to 105	M430F2419T	Samples
MSP430F2419TZQWR	ACTIVE	BGA MICROSTAR JUNIOR	ZQW	113	2500	Green (RoHS & no Sb/Br)	SNAGCU	Level-3-260C-168 HR	-40 to 105	M430F2419T	Samples
MSP430F2616TPM	ACTIVE	LQFP	PM	64	160	Green (RoHS & no Sb/Br)	CU NIPDAU	Level-3-260C-168 HR	-40 to 105	M430F2616T	Samples
MSP430F2616TPMR	ACTIVE	LQFP	PM	64	1000	Green (RoHS & no Sb/Br)	CU NIPDAU	Level-3-260C-168 HR	-40 to 105	M430F2616T	Samples
MSP430F2616TPN	ACTIVE	LQFP	PN	80	119	Green (RoHS & no Sb/Br)	CU NIPDAU	Level-3-260C-168 HR	-40 to 105	M430F2616T	Samples
MSP430F2616TPNR	ACTIVE	LQFP	PN	80	1000	Green (RoHS & no Sb/Br)	CU NIPDAU	Level-3-260C-168 HR	-40 to 105	M430F2616T	Samples
MSP430F2616TZQW	ACTIVE	BGA MICROSTAR JUNIOR	ZQW	113	260	Green (RoHS & no Sb/Br)	SNAGCU	Level-3-260C-168 HR	-40 to 105	M430F2616T	Samples
MSP430F2616TZQWR	ACTIVE	BGA MICROSTAR JUNIOR	ZQW	113	2500	Green (RoHS & no Sb/Br)	SNAGCU	Level-3-260C-168 HR	-40 to 105	M430F2616T	Samples

Orderable Device	Status (1)	Package Type	Package Drawing	Pins	Package Qty	Eco Plan (2)	Lead/Ball Finish (6)	MSL Peak Temp (3)	Op Temp (°C)	Device Marking (4/5)	Samples
MSP430F2617TPM	ACTIVE	LQFP	PM	64	160	Green (RoHS & no Sb/Br)	CU NIPDAU	Level-3-260C-168 HR	-40 to 105	M430F2617T	Samples
MSP430F2617TPMR	ACTIVE	LQFP	PM	64	1000	Green (RoHS & no Sb/Br)	CU NIPDAU	Level-3-260C-168 HR	-40 to 105	M430F2617T	Samples
MSP430F2617TPN	ACTIVE	LQFP	PN	80	119	Green (RoHS & no Sb/Br)	CU NIPDAU	Level-3-260C-168 HR	-40 to 105	M430F2617T	Samples
MSP430F2617TPNR	ACTIVE	LQFP	PN	80	1000	Green (RoHS & no Sb/Br)	CU NIPDAU	Level-3-260C-168 HR	-40 to 105	M430F2617T	Samples
MSP430F2617TZQW	ACTIVE	BGA MICROSTAR JUNIOR	ZQW	113	260	Green (RoHS & no Sb/Br)	SNAGCU	Level-3-260C-168 HR	-40 to 105	M430F2617T	Samples
MSP430F2617TZQWR	ACTIVE	BGA MICROSTAR JUNIOR	ZQW	113	2500	Green (RoHS & no Sb/Br)	SNAGCU	Level-3-260C-168 HR	-40 to 105	M430F2617T	Samples
MSP430F2618TPM	ACTIVE	LQFP	PM	64	160	Green (RoHS & no Sb/Br)	CU NIPDAU	Level-3-260C-168 HR	-40 to 105	M430F2618T	Samples
MSP430F2618TPMR	ACTIVE	LQFP	PM	64	1000	Green (RoHS & no Sb/Br)	CU NIPDAU	Level-3-260C-168 HR	-40 to 105	M430F2618T	Samples
MSP430F2618TPN	ACTIVE	LQFP	PN	80	119	Green (RoHS & no Sb/Br)	CU NIPDAU	Level-3-260C-168 HR	-40 to 105	M430F2618T	Samples
MSP430F2618TPNR	ACTIVE	LQFP	PN	80	1000	Green (RoHS & no Sb/Br)	CU NIPDAU	Level-3-260C-168 HR	-40 to 105	M430F2618T	Samples
MSP430F2618TZQW	ACTIVE	BGA MICROSTAR JUNIOR	ZQW	113	260	Green (RoHS & no Sb/Br)	SNAGCU	Level-3-260C-168 HR	-40 to 105	M430F2618T	Samples
MSP430F2618TZQWR	ACTIVE	BGA MICROSTAR JUNIOR	ZQW	113	2500	Green (RoHS & no Sb/Br)	SNAGCU	Level-3-260C-168 HR	-40 to 105	M430F2618T	Samples
MSP430F2619TPM	ACTIVE	LQFP	PM	64	160	Green (RoHS & no Sb/Br)	CU NIPDAU	Level-3-260C-168 HR	-40 to 105	M430F2619T REV #	Samples
MSP430F2619TPMR	ACTIVE	LQFP	PM	64	1000	Green (RoHS & no Sb/Br)	CU NIPDAU	Level-3-260C-168 HR	-40 to 105	M430F2619T REV #	Samples
MSP430F2619TPN	ACTIVE	LQFP	PN	80	119	Green (RoHS & no Sb/Br)	CU NIPDAU	Level-3-260C-168 HR	-40 to 105	M430F2619T	Samples
MSP430F2619TPNR	ACTIVE	LQFP	PN	80	1000	Green (RoHS & no Sb/Br)	CU NIPDAU	Level-3-260C-168 HR	-40 to 105	M430F2619T	Samples

Orderable Device	Status (1)	Package Type	Package Drawing	Pins	Package Qty	Eco Plan (2)	Lead/Ball Finish (6)	MSL Peak Temp (3)	Op Temp (°C)	Device Marking (4/5)	Samples
MSP430F2619TZQW	ACTIVE	BGA MICROSTAR JUNIOR	ZQW	113	260	Green (RoHS & no Sb/Br)	SNAGCU	Level-3-260C-168 HR	-40 to 105	M430F2619T	Samples
MSP430F2619TZQWR	ACTIVE	BGA MICROSTAR JUNIOR	ZQW	113	2500	Green (RoHS & no Sb/Br)	SNAGCU	Level-3-260C-168 HR	-40 to 105	M430F2619T	Samples

(1) The marketing status values are defined as follows:

ACTIVE: Product device recommended for new designs.

LIFEBUY: TI has announced that the device will be discontinued, and a lifetime-buy period is in effect.

NRND: Not recommended for new designs. Device is in production to support existing customers, but TI does not recommend using this part in a new design.

PREVIEW: Device has been announced but is not in production. Samples may or may not be available.

OBSOLETE: TI has discontinued the production of the device.

(2) **RoHS:** TI defines "RoHS" to mean semiconductor products that are compliant with the current EU RoHS requirements for all 10 RoHS substances, including the requirement that RoHS substance do not exceed 0.1% by weight in homogeneous materials. Where designed to be soldered at high temperatures, "RoHS" products are suitable for use in specified lead-free processes. TI may reference these types of products as "Pb-Free".

RoHS Exempt: TI defines "RoHS Exempt" to mean products that contain lead but are compliant with EU RoHS pursuant to a specific EU RoHS exemption.

Green: TI defines "Green" to mean the content of Chlorine (Cl) and Bromine (Br) based flame retardants meet JS709B low halogen requirements of ≤ 1000 ppm threshold. Antimony trioxide based flame retardants must also meet the ≤ 1000 ppm threshold requirement.

(3) MSL, Peak Temp. - The Moisture Sensitivity Level rating according to the JEDEC industry standard classifications, and peak solder temperature.

(4) There may be additional marking, which relates to the logo, the lot trace code information, or the environmental category on the device.

(5) Multiple Device Markings will be inside parentheses. Only one Device Marking contained in parentheses and separated by a "~" will appear on a device. If a line is indented then it is a continuation of the previous line and the two combined represent the entire Device Marking for that device.

(6) Lead/Ball Finish - Orderable Devices may have multiple material finish options. Finish options are separated by a vertical ruled line. Lead/Ball Finish values may wrap to two lines if the finish value exceeds the maximum column width.

Important Information and Disclaimer: The information provided on this page represents TI's knowledge and belief as of the date that it is provided. TI bases its knowledge and belief on information provided by third parties, and makes no representation or warranty as to the accuracy of such information. Efforts are underway to better integrate information from third parties. TI has taken and continues to take reasonable steps to provide representative and accurate information but may not have conducted destructive testing or chemical analysis on incoming materials and chemicals. TI and TI suppliers consider certain information to be proprietary, and thus CAS numbers and other limited information may not be available for release.

In no event shall TI's liability arising out of such information exceed the total purchase price of the TI part(s) at issue in this document sold by TI to Customer on an annual basis.

OTHER QUALIFIED VERSIONS OF MSP430F2618 :

- Enhanced Product: [MSP430F2618-EP](#)

NOTE: Qualified Version Definitions:

- Enhanced Product - Supports Defense, Aerospace and Medical Applications

TAPE AND REEL INFORMATION

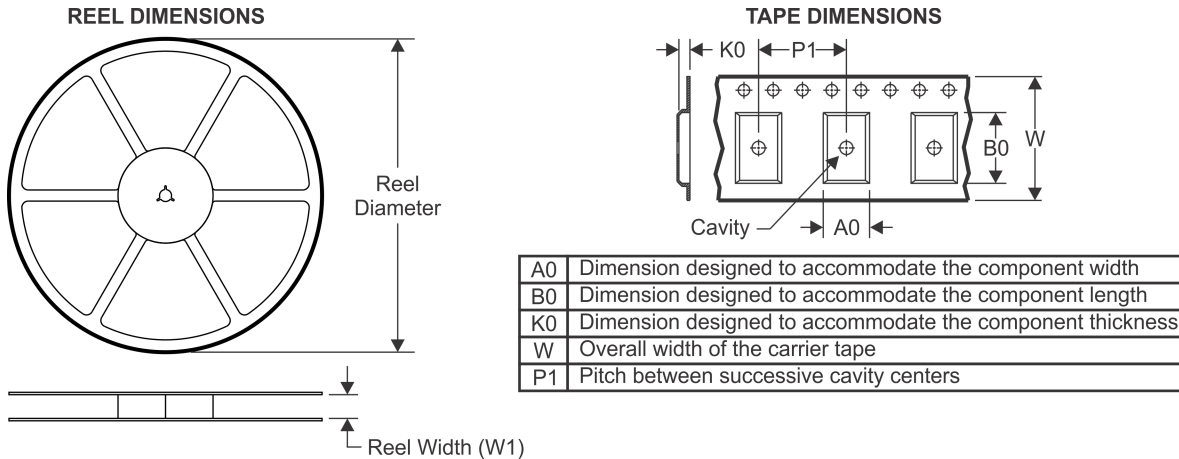

QUADRANT ASSIGNMENTS FOR PIN 1 ORIENTATION IN TAPE

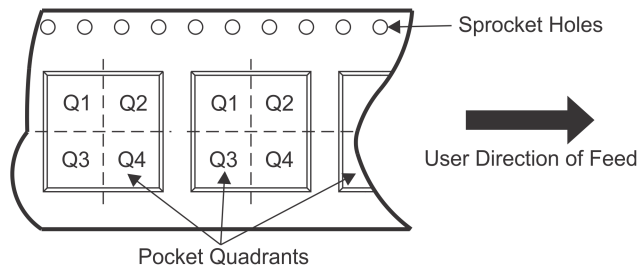

*All dimensions are nominal

Device	Package Type	Package Drawing	Pins	SPQ	Reel Diameter (mm)	Reel Width W1 (mm)	A0 (mm)	B0 (mm)	K0 (mm)	P1 (mm)	W (mm)	Pin1 Quadrant
MSP430F2416TPMR	LQFP	PM	64	1000	330.0	24.4	13.0	13.0	2.1	16.0	24.0	Q2
MSP430F2416TPNR	LQFP	PN	80	1000	330.0	24.4	15.0	15.0	2.1	20.0	24.0	Q2
MSP430F2416TZQWR	BGA MICROSTAR JUNIOR	ZQW	113	2500	330.0	16.4	7.3	7.3	1.5	12.0	16.0	Q1
MSP430F2417TPMR	LQFP	PM	64	1000	330.0	24.4	13.0	13.0	2.1	16.0	24.0	Q2
MSP430F2417TPMR	LQFP	PM	64	1000	330.0	24.4	13.0	13.0	2.1	16.0	24.0	Q2
MSP430F2417TPNR	LQFP	PN	80	1000	330.0	24.4	15.0	15.0	2.1	20.0	24.0	Q2
MSP430F2417TZQWR	BGA MICROSTAR JUNIOR	ZQW	113	2500	330.0	16.4	7.3	7.3	1.5	12.0	16.0	Q1
MSP430F2418TPMR	LQFP	PM	64	1000	330.0	24.4	13.0	13.0	2.1	16.0	24.0	Q2
MSP430F2418TPMR	LQFP	PM	64	1000	330.0	24.4	13.0	13.0	2.1	16.0	24.0	Q2
MSP430F2418TPNR	LQFP	PN	80	1000	330.0	24.4	15.0	15.0	2.1	20.0	24.0	Q2
MSP430F2418TZQWR	BGA MICROSTAR JUNIOR	ZQW	113	2500	330.0	16.4	7.3	7.3	1.5	12.0	16.0	Q1
MSP430F2419TPMR	LQFP	PM	64	1000	330.0	24.4	13.0	13.0	2.1	16.0	24.0	Q2

Device	Package Type	Package Drawing	Pins	SPQ	Reel Diameter (mm)	Reel Width W1 (mm)	A0 (mm)	B0 (mm)	K0 (mm)	P1 (mm)	W (mm)	Pin1 Quadrant
MSP430F2419TPMR	LQFP	PM	64	1000	330.0	24.4	13.0	13.0	2.1	16.0	24.0	Q2
MSP430F2419TPNR	LQFP	PN	80	1000	330.0	24.4	15.0	15.0	2.1	20.0	24.0	Q2
MSP430F2419TZQWR	BGA MICROSTAR JUNIOR	ZQW	113	2500	330.0	16.4	7.3	7.3	1.5	12.0	16.0	Q1
MSP430F2616TPMR	LQFP	PM	64	1000	330.0	24.4	13.0	13.0	2.1	16.0	24.0	Q2
MSP430F2616TPMR	LQFP	PM	64	1000	330.0	24.4	13.0	13.0	2.1	16.0	24.0	Q2
MSP430F2616TPNR	LQFP	PN	80	1000	330.0	24.4	15.0	15.0	2.1	20.0	24.0	Q2
MSP430F2616TZQWR	BGA MICROSTAR JUNIOR	ZQW	113	2500	330.0	16.4	7.3	7.3	1.5	12.0	16.0	Q1
MSP430F2617TPMR	LQFP	PM	64	1000	330.0	24.4	13.0	13.0	2.1	16.0	24.0	Q2
MSP430F2617TPMR	LQFP	PM	64	1000	330.0	24.4	13.0	13.0	2.1	16.0	24.0	Q2
MSP430F2617TPNR	LQFP	PN	80	1000	330.0	24.4	15.0	15.0	2.1	20.0	24.0	Q2
MSP430F2617TZQWR	BGA MICROSTAR JUNIOR	ZQW	113	2500	330.0	16.4	7.3	7.3	1.5	12.0	16.0	Q1
MSP430F2618TPMR	LQFP	PM	64	1000	330.0	24.4	13.0	13.0	2.1	16.0	24.0	Q2
MSP430F2618TPMR	LQFP	PM	64	1000	330.0	24.4	13.0	13.0	2.1	16.0	24.0	Q2
MSP430F2618TPNR	LQFP	PN	80	1000	330.0	24.4	15.0	15.0	2.1	20.0	24.0	Q2
MSP430F2618TZQWR	BGA MICROSTAR JUNIOR	ZQW	113	2500	330.0	16.4	7.3	7.3	1.5	12.0	16.0	Q1
MSP430F2619TPMR	LQFP	PM	64	1000	330.0	24.4	13.0	13.0	2.1	16.0	24.0	Q2
MSP430F2619TPMR	LQFP	PM	64	1000	330.0	24.4	13.0	13.0	2.1	16.0	24.0	Q2
MSP430F2619TPNR	LQFP	PN	80	1000	330.0	24.4	15.0	15.0	2.1	20.0	24.0	Q2
MSP430F2619TZQWR	BGA MICROSTAR JUNIOR	ZQW	113	2500	330.0	16.4	7.3	7.3	1.5	12.0	16.0	Q1

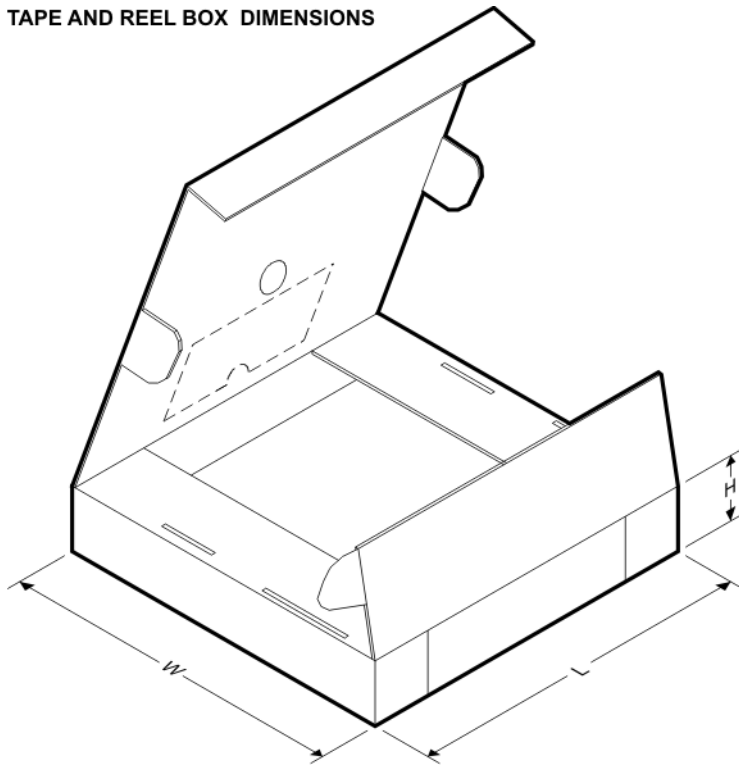
TAPE AND REEL BOX DIMENSIONS

*All dimensions are nominal

Device	Package Type	Package Drawing	Pins	SPQ	Length (mm)	Width (mm)	Height (mm)
MSP430F2416TPMR	LQFP	PM	64	1000	350.0	350.0	43.0
MSP430F2416TPNR	LQFP	PN	80	1000	350.0	350.0	43.0
MSP430F2416TZQWR	BGA MICROSTAR JUNIOR	ZQW	113	2500	350.0	350.0	43.0
MSP430F2417TPMR	LQFP	PM	64	1000	350.0	350.0	43.0
MSP430F2417TPMR	LQFP	PM	64	1000	336.6	336.6	41.3
MSP430F2417TPNR	LQFP	PN	80	1000	350.0	350.0	43.0
MSP430F2417TZQWR	BGA MICROSTAR JUNIOR	ZQW	113	2500	350.0	350.0	43.0
MSP430F2418TPMR	LQFP	PM	64	1000	336.6	336.6	41.3
MSP430F2418TPMR	LQFP	PM	64	1000	350.0	350.0	43.0
MSP430F2418TPNR	LQFP	PN	80	1000	350.0	350.0	43.0
MSP430F2418TZQWR	BGA MICROSTAR JUNIOR	ZQW	113	2500	350.0	350.0	43.0
MSP430F2419TPMR	LQFP	PM	64	1000	336.6	336.6	41.3
MSP430F2419TPMR	LQFP	PM	64	1000	350.0	350.0	43.0
MSP430F2419TPNR	LQFP	PN	80	1000	350.0	350.0	43.0
MSP430F2419TZQWR	BGA MICROSTAR JUNIOR	ZQW	113	2500	350.0	350.0	43.0
MSP430F2616TPMR	LQFP	PM	64	1000	336.6	336.6	41.3
MSP430F2616TPMR	LQFP	PM	64	1000	350.0	350.0	43.0
MSP430F2616TPNR	LQFP	PN	80	1000	350.0	350.0	43.0

Device	Package Type	Package Drawing	Pins	SPQ	Length (mm)	Width (mm)	Height (mm)
MSP430F2616TZQWR	BGA MICROSTAR JUNIOR	ZQW	113	2500	350.0	350.0	43.0
MSP430F2617TPMR	LQFP	PM	64	1000	336.6	336.6	41.3
MSP430F2617TPMR	LQFP	PM	64	1000	350.0	350.0	43.0
MSP430F2617TPNR	LQFP	PN	80	1000	350.0	350.0	43.0
MSP430F2617TZQWR	BGA MICROSTAR JUNIOR	ZQW	113	2500	350.0	350.0	43.0
MSP430F2618TPMR	LQFP	PM	64	1000	350.0	350.0	43.0
MSP430F2618TPMR	LQFP	PM	64	1000	336.6	336.6	41.3
MSP430F2618TPNR	LQFP	PN	80	1000	350.0	350.0	43.0
MSP430F2618TZQWR	BGA MICROSTAR JUNIOR	ZQW	113	2500	350.0	350.0	43.0
MSP430F2619TPMR	LQFP	PM	64	1000	336.6	336.6	41.3
MSP430F2619TPMR	LQFP	PM	64	1000	350.0	350.0	43.0
MSP430F2619TPNR	LQFP	PN	80	1000	350.0	350.0	43.0
MSP430F2619TZQWR	BGA MICROSTAR JUNIOR	ZQW	113	2500	350.0	350.0	43.0

ZQW (S-PBGA-N113)

PLASTIC BALL GRID ARRAY

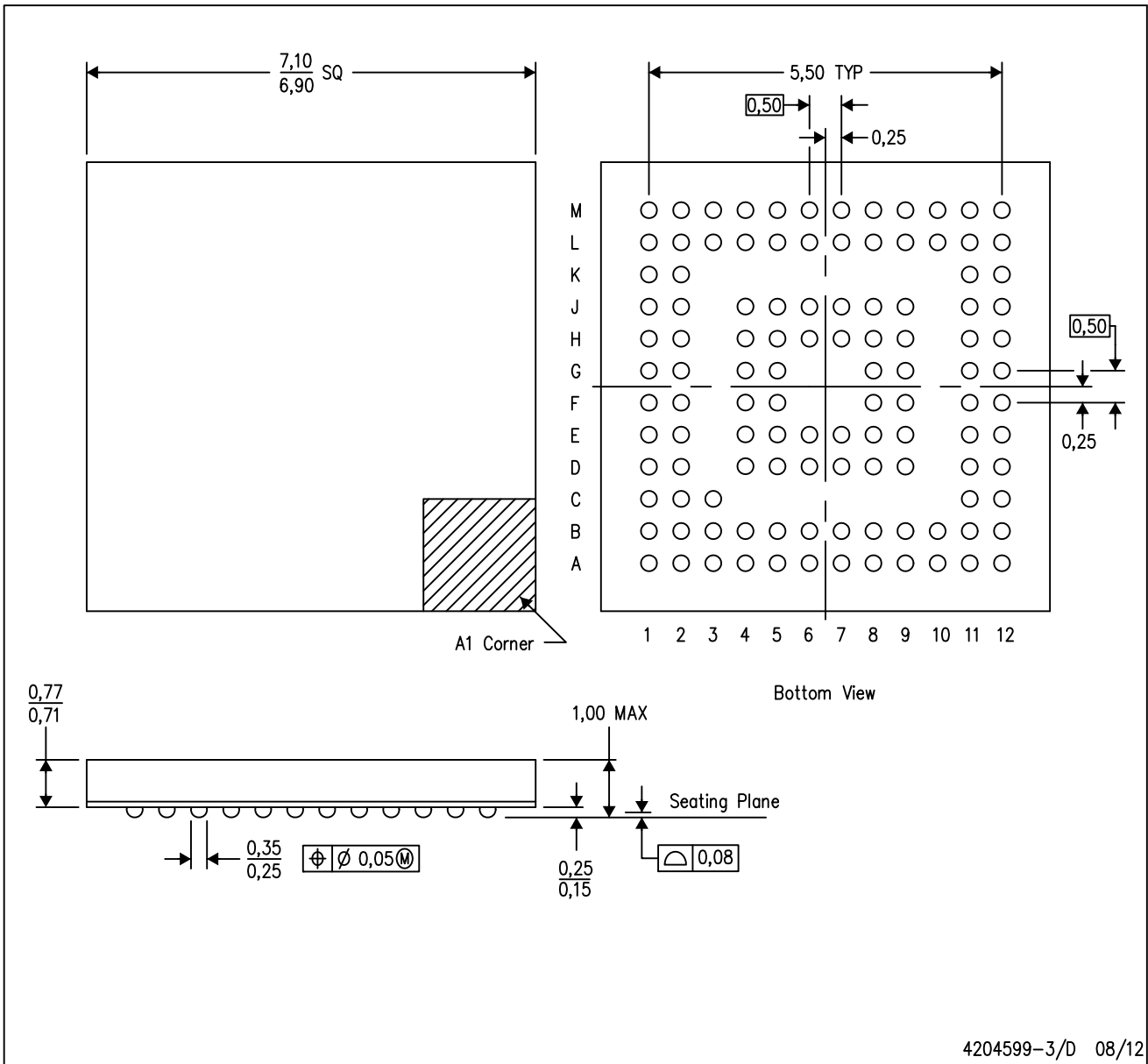

- NOTES:
- A. All linear dimensions are in millimeters.
 - B. This drawing is subject to change without notice.
 - C. Falls within JEDEC MO-225
 - D. This is a Pb-free solder ball design.

MicroStar Junior is a trademark of Texas Instruments.

PN (S-PQFP-G80)

PLASTIC QUAD FLATPACK

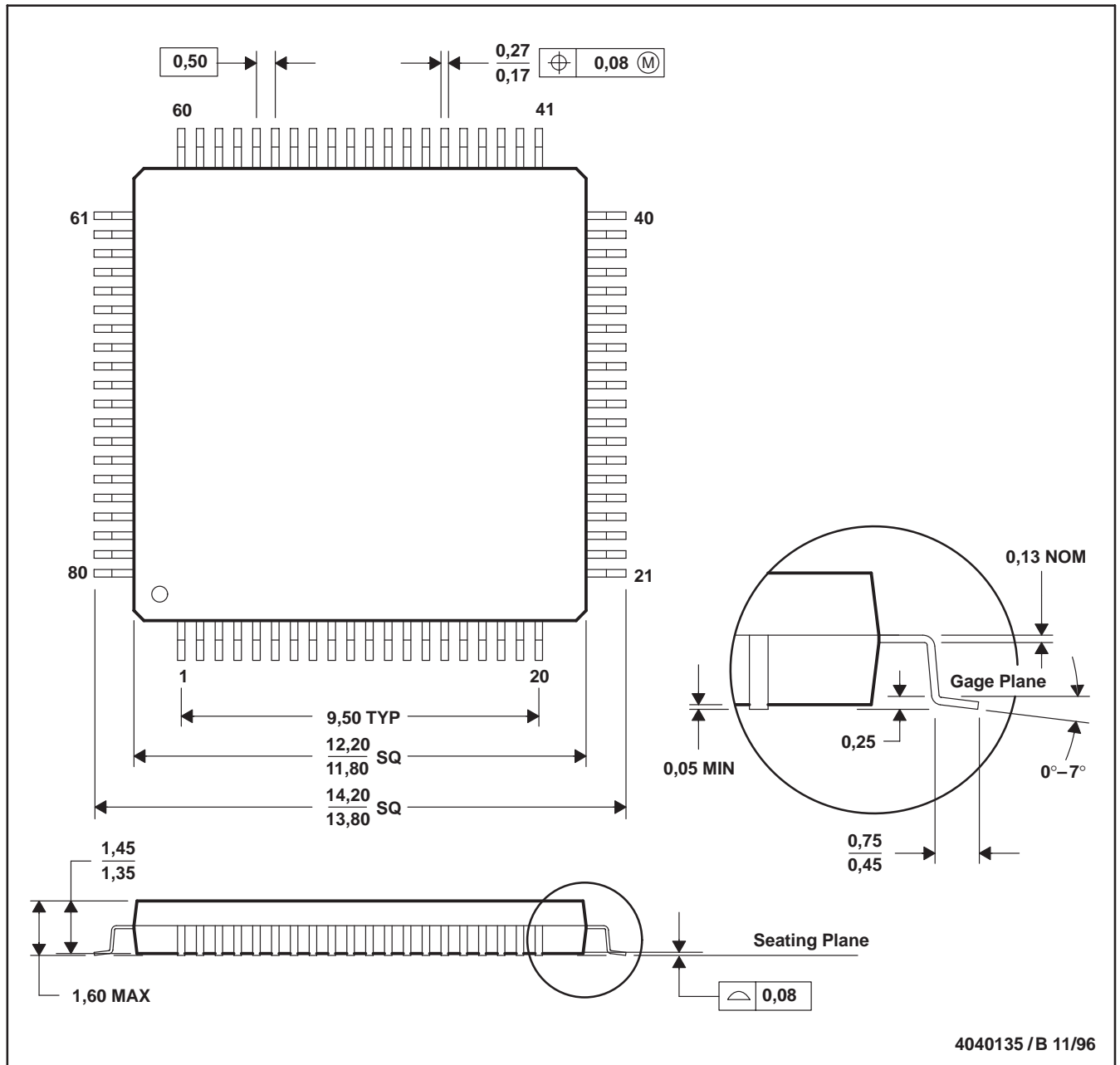

- NOTES: A. All linear dimensions are in millimeters.
 B. This drawing is subject to change without notice.
 C. Falls within JEDEC MS-026

PM (S-PQFP-G64)

PLASTIC QUAD FLATPACK

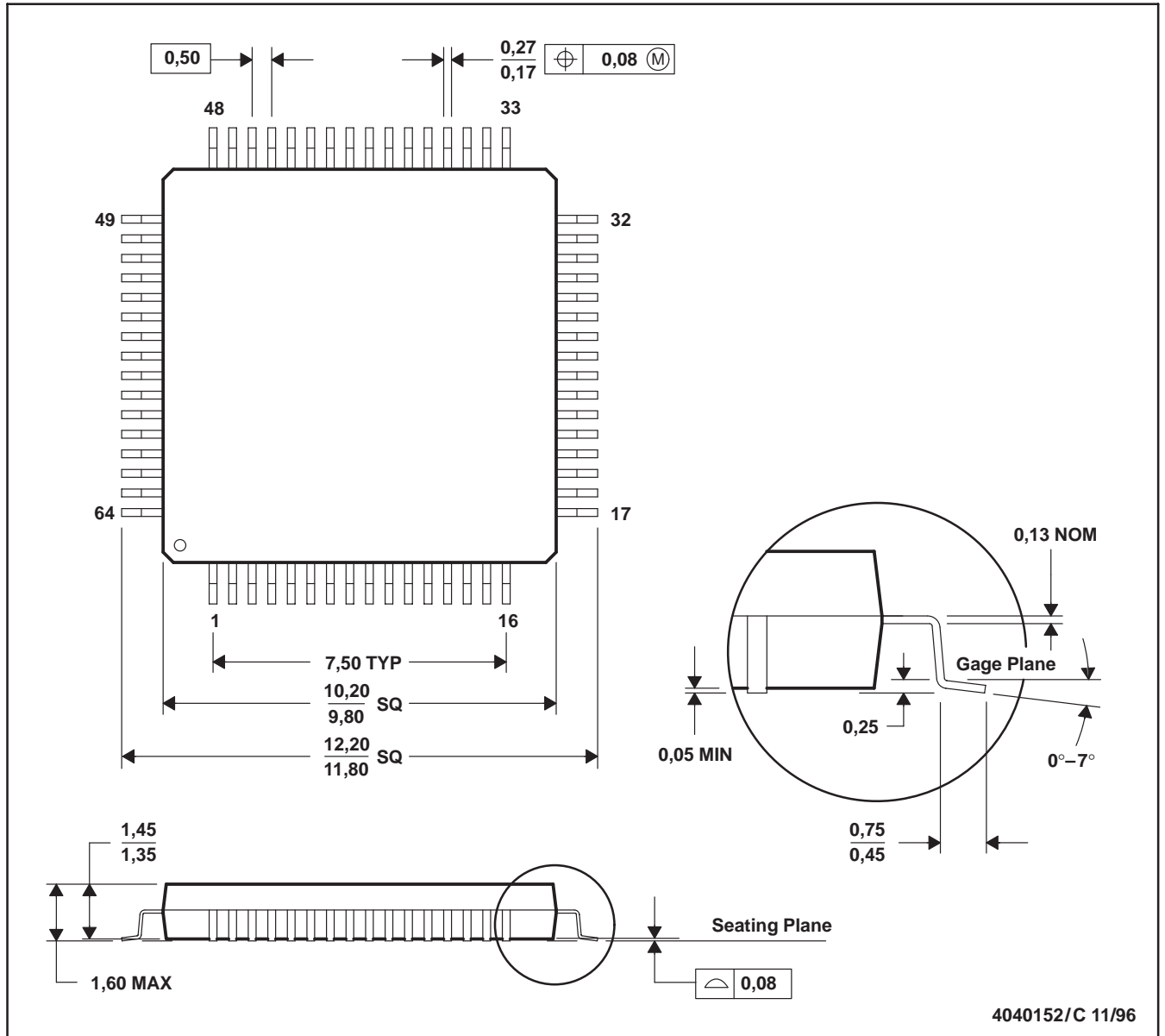

- NOTES: A. All linear dimensions are in millimeters.
 B. This drawing is subject to change without notice.
 C. Falls within JEDEC MS-026
 D. May also be thermally enhanced plastic with leads connected to the die pads.

PM (S-PQFP-G64)

PLASTIC QUAD FLATPACK

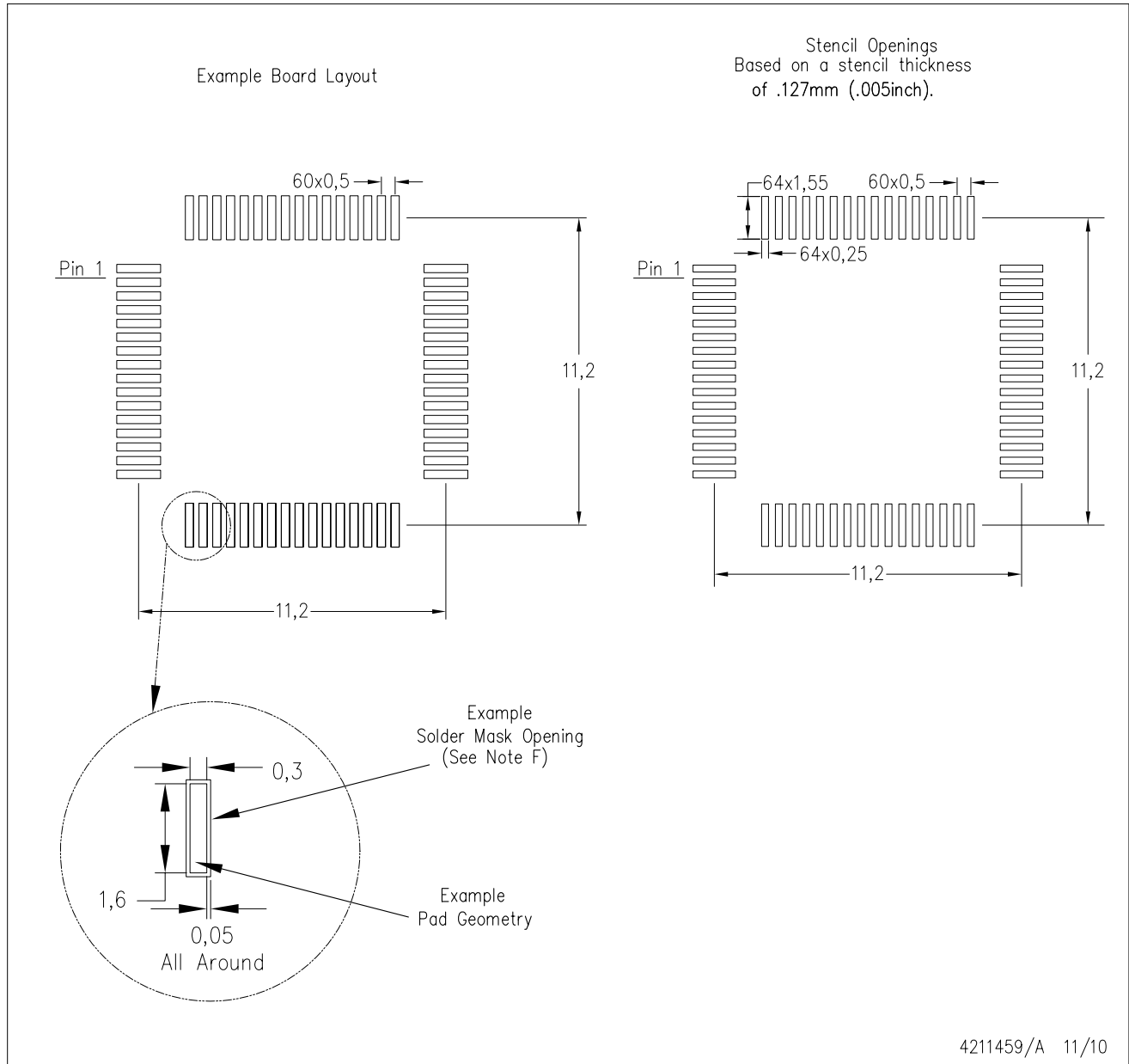

- NOTES:
- A. All linear dimensions are in millimeters.
 - B. This drawing is subject to change without notice.
 - C. Laser cutting apertures with trapezoidal walls and also rounding corners will offer better paste release. Customers should contact their board assembly site for stencil design recommendations. Example stencil design based on a 50% volumetric metal load solder paste. Refer to IPC-7525 for other stencil recommendations.
 - D. Customers should contact their board fabrication site for solder mask tolerances between and around signal pads.

IMPORTANT NOTICE AND DISCLAIMER

TI PROVIDES TECHNICAL AND RELIABILITY DATA (INCLUDING DATASHEETS), DESIGN RESOURCES (INCLUDING REFERENCE DESIGNS), APPLICATION OR OTHER DESIGN ADVICE, WEB TOOLS, SAFETY INFORMATION, AND OTHER RESOURCES "AS IS" AND WITH ALL FAULTS, AND DISCLAIMS ALL WARRANTIES, EXPRESS AND IMPLIED, INCLUDING WITHOUT LIMITATION ANY IMPLIED WARRANTIES OF MERCHANTABILITY, FITNESS FOR A PARTICULAR PURPOSE OR NON-INFRINGEMENT OF THIRD PARTY INTELLECTUAL PROPERTY RIGHTS.

These resources are intended for skilled developers designing with TI products. You are solely responsible for (1) selecting the appropriate TI products for your application, (2) designing, validating and testing your application, and (3) ensuring your application meets applicable standards, and any other safety, security, or other requirements. These resources are subject to change without notice. TI grants you permission to use these resources only for development of an application that uses the TI products described in the resource. Other reproduction and display of these resources is prohibited. No license is granted to any other TI intellectual property right or to any third party intellectual property right. TI disclaims responsibility for, and you will fully indemnify TI and its representatives against, any claims, damages, costs, losses, and liabilities arising out of your use of these resources.

TI's products are provided subject to TI's Terms of Sale (www.ti.com/legal/termsofsale.html) or other applicable terms available either on ti.com or provided in conjunction with such TI products. TI's provision of these resources does not expand or otherwise alter TI's applicable warranties or warranty disclaimers for TI products.

Mailing Address: Texas Instruments, Post Office Box 655303, Dallas, Texas 75265
Copyright © 2019, Texas Instruments Incorporated

Looking for pricing, stock, or lifecycle information?

Click below to explore more details on WIN SOURCE:

 [View MSP430F2616TPMR on WIN SOURCE](#)

 [Texas Instruments](#) Information

Optimize Your Supply Chain with WIN SOURCE Solutions

-  Global Sourcing Solution
-  Obsolete Management
-  Cost Control Management
-  Shortage Management
-  Alternative Solution
-  Excess Inventory Management