



**THE DATASHEET OF  
MSP430FG437IPNR**



## MSP430FG43x Mixed-Signal Microcontrollers

### 1 Features

- Low supply-voltage range, 1.8 V to 3.6 V
- Ultra-low power consumption
  - Active mode: 300  $\mu$ A at 1 MHz, 2.2 V
  - Standby mode: 1.1  $\mu$ A
  - Off mode (RAM retention): 0.1  $\mu$ A
- Five power-saving modes
- Wakeup from standby mode in less than 6  $\mu$ s
- 16-bit RISC architecture, 125-ns instruction cycle time
- Single-channel internal DMA
- 12-bit analog-to-digital converter (ADC) with internal reference, sample-and-hold and autoscan feature
- Three configurable operational amplifiers
- Dual 12-bit digital-to-analog converters (DACs) with synchronization
- 16-bit Timer\_A with three capture/compare registers
- 16-bit Timer\_B with three capture/compare-with-shadow registers
- On-chip comparator
- Serial communication interface (USART), select asynchronous UART or synchronous SPI by software
- Brownout detector
- Supply-voltage supervisor and monitor with programmable level detection
- Bootloader (BSL)
- Serial onboard programming, no external programming voltage needed, programmable code protection by security fuse
- Integrated segment liquid crystal display (LCD) driver for up to 128 segments
- Available in 113-ball BGA (ZCA) and 80-pin QFP (PN) packages
- [Device Comparison](#) summarizes the available family members

### 2 Applications

- Analog and Digital Sensor Systems
- Digital Motor Control
- Remote Controls
- Thermostats
- Digital Timers
- Hand-Held Meters

### 3 Description

The Texas Instruments MSP430™ family of ultra-low-power microcontrollers consists of several devices featuring different sets of peripherals targeted for various applications. The architecture, combined with five low-power modes, is optimized to achieve extended battery life in portable measurement applications. The device features a powerful 16-bit RISC CPU, 16-bit registers, and constant generators that contribute to maximum code efficiency. The digitally controlled oscillator (DCO) allows the device to wake up from low-power modes to active mode in less than 6  $\mu$ s.

The MSP430FG43x devices are microcontrollers with two 16-bit timers, a high-performance 12-bit ADC, dual 12-bit DACs, three configurable operational amplifiers, one universal synchronous/asynchronous communication interface, DMA, 48 I/O pins, and an LCD driver.

For complete module descriptions, see the [MSP430x4xx Family User's Guide](#).

#### Device Information

PART NUMBER <sup>(1)</sup>	PACKAGE	BODY SIZE <sup>(2)</sup>
MSP430FG439PN	LQFP (80)	12 mm x 12 mm
MSP430FG439ZCA	BGA (113)	7 mm x 7 mm

- (1) For the most current device, package, and ordering information, see the Package Option Addendum in [Section 11](#), or see the TI web site at [www.ti.com](http://www.ti.com).
- (2) The sizes shown here are approximations. For the package dimensions with tolerances, see the Mechanical Data in [Section 11](#).



## 4 Functional Block Diagram

Figure 4-1 shows the functional block diagram.

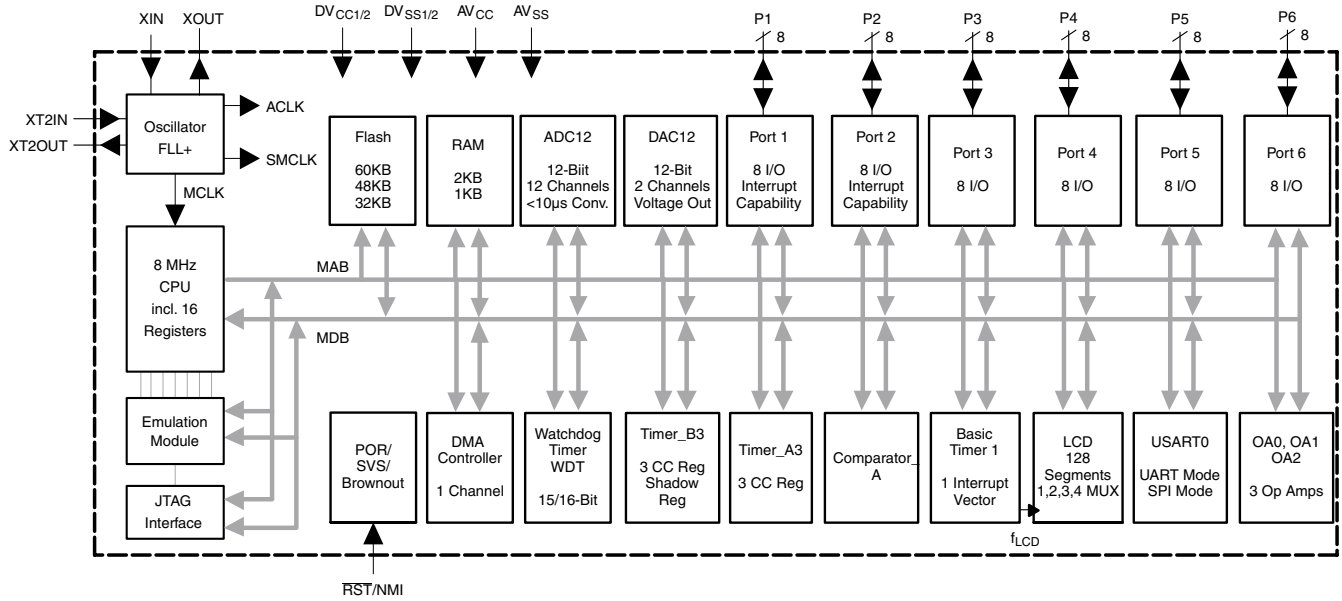

**Functional Block Diagram**

## Table of Contents

<b>1 Features</b> .....	1	8.26 12-Bit ADC, Linearity Parameters.....	30
<b>2 Applications</b> .....	1	8.27 12-Bit ADC, Temperature Sensor and Built-In V <sub>MID</sub> .....	31
<b>3 Description</b> .....	1	8.28 12-Bit DAC, Supply Specifications.....	31
<b>4 Functional Block Diagram</b> .....	2	8.29 12-Bit DAC, Linearity Specifications.....	32
<b>5 Revision History</b> .....	4	8.30 12-Bit DAC, Output Specifications.....	34
<b>6 Device Comparison</b> .....	5	8.31 12-Bit DAC, Reference Input Specifications.....	35
<b>7 Terminal Configuration and Functions</b> .....	6	8.32 12-Bit DAC, Dynamic Specifications.....	35
7.1 Pin Diagrams.....	6	8.33 12-Bit DAC, Dynamic Specifications (Continued)...	36
7.2 Signal Descriptions.....	8	8.34 Operational Amplifier (OA), Supply Specifications..	37
<b>8 Specifications</b> .....	12	8.35 Operational Amplifier (OA), Input/Output Specifications.....	37
8.1 Absolute Maximum Ratings.....	12	8.36 Operational Amplifier (OA), Dynamic Specifications.....	38
8.2 Handling Ratings.....	12	8.37 OA Dynamic Specifications Typical Characteristics.....	38
8.3 Recommended Operating Conditions.....	12	8.38 Flash Memory.....	39
8.4 Supply Current Into AV <sub>CC</sub> + DV <sub>CC</sub> Excluding External Current.....	14	8.39 JTAG Interface.....	39
8.5 Schmitt-Trigger Inputs – Ports P1 to P6, $\overline{\text{RST}}$ / NMI, JTAG (TCK, TMS, TDI/TCLK, TDO/TDI).....	15	8.40 JTAG Fuse.....	39
8.6 Inputs Px.y, TAx, TBx.....	15	<b>9 Detailed Description</b> .....	40
8.7 Leakage Current – Ports P1 to P6.....	15	9.1 CPU.....	40
8.8 Outputs – Ports P1 to P6.....	16	9.2 Instruction Set.....	41
8.9 Output Frequency.....	16	9.3 Operating Modes.....	42
8.10 Typical Characteristics – Outputs.....	17	9.4 Interrupt Vector Addresses.....	43
8.11 Wake-Up From LPM3.....	18	9.5 Special Function Registers (SFRs).....	44
8.12 RAM.....	18	9.6 Memory Organization.....	46
8.13 LCD.....	18	9.7 Bootstrap Loader (BSL).....	47
8.14 Comparator_A.....	19	9.8 Flash Memory.....	47
8.15 Comparator_A Typical Characteristics.....	19	9.9 Peripherals.....	48
8.16 Power-On Reset (POR) and Brownout Reset (BOR).....	21	9.10 Input/Output Schematics.....	55
8.17 Supply Voltage Supervisor (SVS) and Supply Voltage Monitor (SVM).....	22	<b>10 Device and Documentation Support</b> .....	78
8.18 DCO.....	24	10.1 Device Support.....	78
8.19 Crystal Oscillator, XT1 Oscillator .....	26	10.2 Documentation Support.....	80
8.20 Crystal Oscillator, XT2 Oscillator.....	26	10.3 Support Resources.....	80
8.21 USART0.....	26	10.4 Trademarks.....	80
8.22 12-Bit ADC, Power Supply and Input Range Conditions.....	27	10.5 Electrostatic Discharge Caution.....	80
8.23 12-Bit ADC, External Reference.....	27	10.6 Glossary.....	80
8.24 12-Bit ADC, Built-In Reference.....	28	<b>11 Mechanical Packaging and Orderable Information..</b>	<b>81</b>
8.25 12-Bit ADC, Timing Parameters.....	30	11.1 Packaging Information.....	81

## 5 Revision History

NOTE: Page numbers for previous revisions may differ from page numbers in the current version.

Changes from revision E to revision F

<b>Changes from June 18, 2021 to March 31, 2022</b>	<b>Page</b>
• Changed the $t_{\text{CONVERT}}$ MIN value to 1.86 $\mu\text{s}$ and removed ADC12DIV from the formula for the TYP value (because ADC12CLK is after this division) in <a href="#">Section 8.25 12-Bit ADC, Timing Parameters</a> .....	30
• Changed the $R_{i(\text{VREF+})}$ , $R_{i(\text{VeREF+})}$ reference input resistance MAX value to 150k $\Omega$ for DAC12_0 IR=1, DAC12_1 IR=0 in <a href="#">Section 8.31 12-Bit DAC, Reference Input Specifications</a> .....	35
• Changed the $R_{i(\text{VREF+})}$ , $R_{i(\text{VeREF+})}$ reference input resistance MAX value to 150k $\Omega$ for DAC12_0 IR=0, DAC12_1 IR=1 in <a href="#">Section 8.31 12-Bit DAC, Reference Input Specifications</a> .....	35
• Changed the $R_{i(\text{VREF+})}$ , $R_{i(\text{VeREF+})}$ reference input resistance MAX value to 75k $\Omega$ for DAC12_0 IR=DAC12_1 IR=1 in <a href="#">Section 8.31 12-Bit DAC, Reference Input Specifications</a> .....	35
• Updated <a href="#">Section 10.3, Support Resources</a> .....	80

## 6 Device Comparison

The following table summarizes the available family members.

**Table 6-1. Device Comparison**

Device <sup>(1)</sup>	FLASH (KB) <sup>(2)</sup>	SRAM (KB)	ADC12	DAC12	Comp_A	Timer_A <sup>(3)</sup>	Timer_B <sup>(4)</sup>	USART	LCD	I/Os	Package Type
MSP430FG439	60	2	12 channels	2 channels	16 channels	3	3	Yes	Yes	48	80 PN 113 ZCA
MSP430FG438	48	2	12 channels	2 channels	16 channels	3	3	Yes	Yes	48	80 PN 113 ZCA
MSP430FG437	32	1	12 channels	2 channels	16 channels	3	3	Yes	Yes	48	80 PN 113 ZCA

- (1) For the most current package and ordering information, see the Package Option Addendum in [Section 11](#), or see the TI web site at [www.ti.com](http://www.ti.com).
- (2) Package drawings, standard packing quantities, thermal data, symbolization, and PCB design guidelines are available at [www.ti.com/packaging](http://www.ti.com/packaging).
- (3) Each number in the sequence represents an instantiation of Timer\_A with its associated number of capture/compare registers and PWM output generators available. For example, a number sequence of 3, 5 would represent two instantiations of Timer\_A, the first instantiation having 3 capture/compare registers and PWM output generators and the second instantiation having 5 capture/compare registers and PWM output generators, respectively.
- (4) Each number in the sequence represents an instantiation of Timer\_B with its associated number of capture/compare registers and PWM output generators available. For example, a number sequence of 3, 5 would represent two instantiations of Timer\_B, the first instantiation having 3 capture/compare registers and PWM output generators and the second instantiation having 5 capture/compare registers and PWM output generators, respectively.

## 7 Terminal Configuration and Functions

### 7.1 Pin Diagrams

Figure 7-1 shows the pin assignments for the 80-pin PN package.

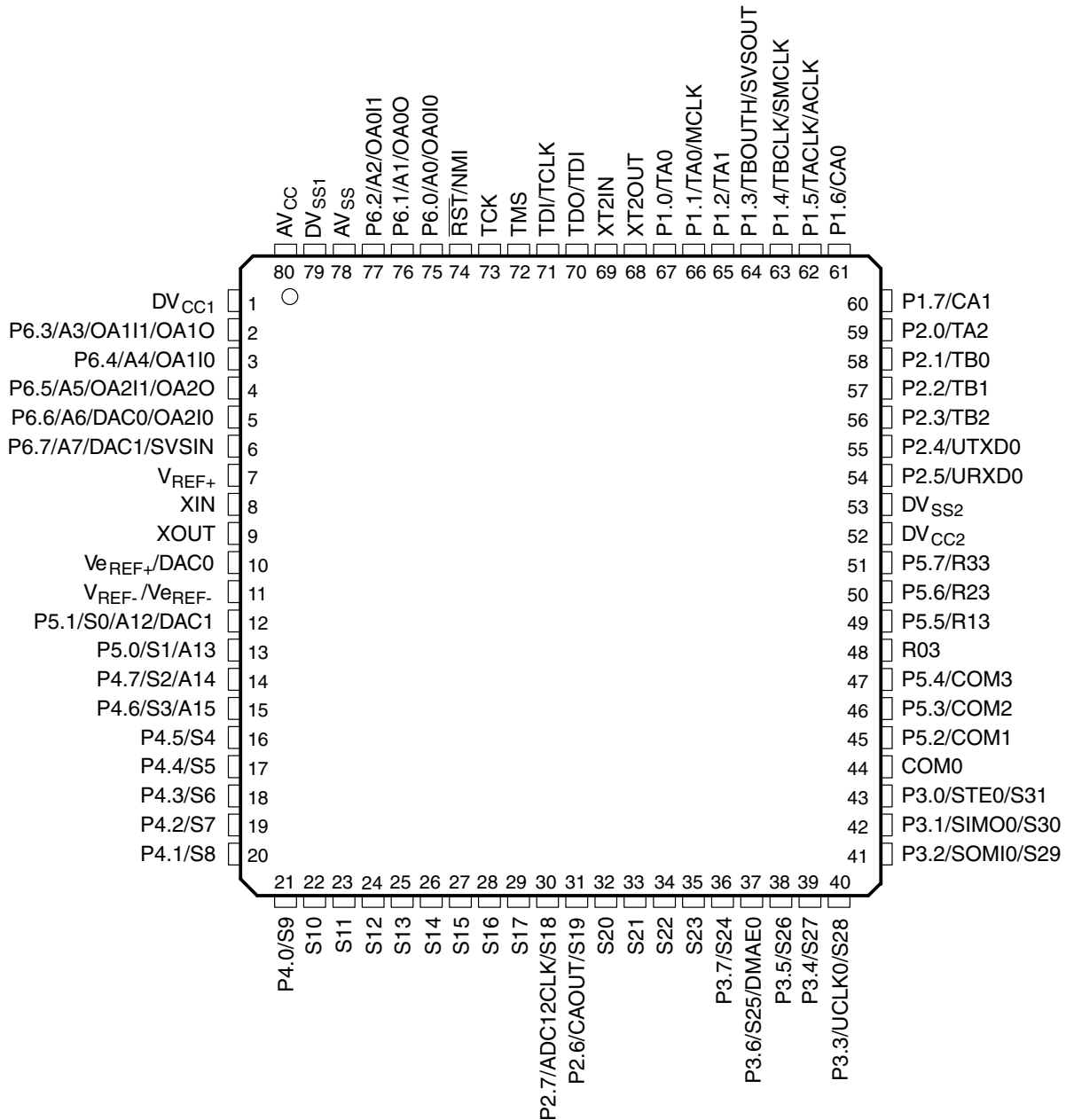

Figure 7-1. 80-Pin PN Package (Top View)

Figure 7-2 shows the pin assignments for the 113-pin ZCA package.

**ZCA PACKAGE  
(TOP VIEW)**

DVSS (A1)	AVSS (A2)	AVCC (A3)	P6.1 (A4)	P6.0 (A5)	RST (A6)	XT2IN (A7)	XT2OUT (A8)	DVSS (A9)	P1.3 (A10)	P1.6 (A11)	(A12)
DVCC (B1)	DVSS (B2)	AVCC (B3)	P6.2 (B4)	P6.3 (B5)	DVSS (B6)	DVSS (B7)	DVSS (B8)	P1.2 (B9)	P1.5 (B10)	(B11)	P1.7 (B12)
VREF+ (C1)	DVCC (C2)	DVSS (C3)								P2.0 (C11)	P2.4/TX (C12)
AVSS (D1)	P6.7 (D2)		P6.5 (D4)	P6.4 (D5)	TMS (D6)	TDO (D7)	P1.0 (D8)	P1.1 (D9)		P2.1 (D11)	P2.5/RX (D12)
XIN (E1)	AVSS (E2)		P6.6 (E4)	(E5)	TCK (E6)	TDI (E7)	(E8)	P1.4 (E9)		P2.2 (E11)	DVSS2 (E12)
XOUT (F1)	AVSS (F2)		P5.1 (F4)	(F5)			(F8)	(F9)		P2.3 (F11)	DVCC2 (F12)
AVSS (G1)	AVSS (G2)		P5.0 (G4)	(G5)			(G8)	(G9)		COM3 (G11)	R33 (G12)
VeREF+ (H1)	AVSS (H2)		P4.7 (H4)	(H5)	(H6)	(H7)	(H8)	(H9)		COM2 (H11)	R23 (H12)
VREF- (J1)	AVSS (J2)		P4.6 (J4)	S13 (J5)	S16 (J6)	S21 (J7)	S22 (J8)	S23 (J9)		COM1 (J11)	R13 (J12)
P4.5 (K1)	P4.4 (K2)									COM0 (K11)	R03 (K12)
P4.1 (L1)	P4.2 (L2)	P4.3 (L3)	S11 (L4)	S14 (L5)	S17 (L6)	S20 (L7)	P3.6/S25 (L8)	P3.5/S26 (L9)	P3.4/S27 (L10)	(L11)	P3.0/S31 (L12)
(M1)	P4.0 (M2)	S10 (M3)	S12 (M4)	S15 (M5)	P2.7/S18 (M6)	P2.6/S19 (M7)	P3.7/S24 (M8)	P3.3/S28 (M9)	P3.2/S29 (M10)	P3.1/S30 (M11)	(M12)

**Figure 7-2. 113-Pin ZCA Package (Top View)**

## 7.2 Signal Descriptions

Section 7.2.1 describes the signals for all device variants and package options.

### 7.2.1 Signal Descriptions

TERMINAL			I/O	DESCRIPTION
NAME	NO.			
	PN	ZCA		
DVCC1	1	B1, C2		Digital supply voltage, positive terminal.
P6.3/A3/OA111/OA10	2	B5	I/O	General-purpose digital I/O Analog input a3—12-bit ADC OA1 output and/or input multiplexer on +terminal and –terminal
P6.4/A4/OA110	3	D5	I/O	General-purpose digital I/O Analog input a4—12-bit ADC OA1 input multiplexer on +terminal and –terminal
P6.5/A5/OA211/OA20	4	D4	I/O	General-purpose digital I/O Analog input a5—12-bit ADC OA2 output and/or input multiplexer on +terminal and –terminal
P6.6/A6/DAC0/OA210	5	E4	I/O	General-purpose digital I/O Analog input a6—12-bit ADC DAC12.0 output OA2 input multiplexer on +terminal and –terminal
P6.7/A7/DAC1/SVSIN	6	D2	I/O	General-purpose digital I/O Analog input a7—12-bit ADC DAC12.1 output/analog input to supply voltage supervisor
VREF+	7	C1	O	Positive output terminal of the reference voltage in the ADC
XIN	8	E1	I	Input terminal of crystal oscillator XT1
XOUT	9	F1	O	Output terminal of crystal oscillator XT1
VeREF+/DAC0	10	H1	I/O	Positive input terminal for an external reference voltage to the 12-bit ADC/DAC12.0 output
VREF–/VeREF–	11	J1	I	Negative terminal for the 12-bit ADC's reference voltage for both sources, the internal reference voltage or an external applied reference voltage to the 12-bit ADC.
P5.1/S0/A12/DAC1	12	F4	I/O	General-purpose digital I/O LCD segment output 0 Analog input a12—12-bit ADC DAC12.1 output
P5.0/S1/A13	13	G4	I/O	General-purpose digital I/O LCD segment output 1 Analog input a13—12-bit ADC
P4.7/S2/A14	14	H4	I/O	General-purpose digital I/O LCD segment output 2 Analog input a14—12-bit ADC
P4.6/S3/A15	15	J4	I/O	General-purpose digital I/O LCD segment output 3 Analog input a15—12-bit ADC
P4.5/S4	16	K1	I/O	General-purpose digital I/O LCD segment output 4
P4.4/S5	17	K2	I/O	General-purpose digital I/O LCD segment output 5
P4.3/S6	18	L3	I/O	General-purpose digital I/O LCD segment output 6
P4.2/S7	19	L2	I/O	General-purpose digital I/O LCD segment output 7
P4.1/S8	20	L1	I/O	General-purpose digital I/O LCD segment output 8

TERMINAL			I/O	DESCRIPTION
NAME	NO.			
	PN	ZCA		
P4.0/S9	21	M2	I/O	General-purpose digital I/O LCD segment output 9
S10	22	M3	O	LCD segment output 10
S11	23	L4	O	LCD segment output 11
S12	24	M4	O	LCD segment output 12
S13	25	J5	O	LCD segment output 13
S14	26	L5	O	LCD segment output 14
S15	27	M5	O	LCD segment output 15
S16	28	J6	O	LCD segment output 16
S17	29	L6	O	LCD segment output 17
P2.7/ADC12CLK/S18	30	M6	I/O	General-purpose digital I/O Conversion clock—12-bit ADC LCD segment output 18
P2.6/CAOUT/S19	31	M7	I/O	General-purpose digital I/O Comparator_A output / LCD segment output 19
S20	32	L7	O	LCD segment output 20
S21	33	J7	O	LCD segment output 21
S22	34	J8	O	LCD segment output 22
S23	35	J9	O	LCD segment output 23
P3.7/S24	36	M8	I/O	General-purpose digital I/O LCD segment output 24
P3.6/S25/DMAE0	37	L8	I/O	General-purpose digital I/O LCD segment output 25/DMA Channel 0 external trigger
P3.5/S26	38	L9	I/O	General-purpose digital I/O LCD segment output 26
P3.4/S27	39	L10	I/O	General-purpose digital I/O LCD segment output 27
P3.3/UCLK0/S28	40	M9	I/O	General-purpose digital I/O External clock input—USART0/UART or SPI mode, clock output—USART0/SPI mode LCD segment output 28
P3.2/SOMI0/S29	41	M10	I/O	General-purpose digital I/O Slave out/master in of USART0/SPI mode LCD segment output 29
P3.1/SIMO0/S30	42	M11	I/O	General-purpose digital I/O Slave in/master out of USART0/SPI mode LCD segment output 30
P3.0/STE0/S31	43	L12	I/O	General-purpose digital I/O Slave transmit enable-USART0/SPI mode LCD segment output 31
COM0	44	K11	O	Common output, COM0–3 are used for LCD backplanes.
P5.2/COM1	45	J11	I/O	General-purpose digital I/O Common output, COM0–3 are used for LCD backplanes.
P5.3/COM2	46	H11	I/O	General-purpose digital I/O Common output, COM0–3 are used for LCD backplanes.
P5.4/COM3	47	G11	I/O	General-purpose digital I/O Common output, COM0–3 are used for LCD backplanes.
R03	48	K12	I	Input port of fourth positive (lowest) analog LCD level (V5)
P5.5/R13	49	J12	I/O	General-purpose digital I/O input port of third most positive analog LCD level (V4 or V3)

TERMINAL			I/O	DESCRIPTION
NAME	NO.			
	PN	ZCA		
P5.6/R23	50	H12	I/O	General-purpose digital I/O Input port of second most positive analog LCD level (V2)
P5.7/R33	51	G12	I/O	General-purpose digital I/O Output port of most positive analog LCD level (V1)
DVCC2	52	F12		Digital supply voltage, positive terminal
DVSS2	53	E12		Digital supply voltage, negative terminal
P2.5/URXD0	54	D12	I/O	General-purpose digital I/O Receive data in—USART0/UART mode
P2.4/UTXD0	55	C12	I/O	General-purpose digital I/O Transmit data out—USART0/UART mode
P2.3/TB2	56	F11	I/O	General-purpose digital I/O Timer_B3 CCR2. Capture: CCI2A/CCI2B input, compare: Out2 output
P2.2/TB1	57	E11	I/O	General-purpose digital I/O Timer_B3 CCR1. Capture: CCI1A/CCI1B input, compare: Out1 output
P2.1/TB0	58	D11	I/O	General-purpose digital I/O Timer_B3 CCR0. Capture: CCI0A/CCI0B input, compare: Out0 output
P2.0/TA2	59	C11	I/O	General-purpose digital I/O Timer_A Capture: CCI2A input, compare: Out2 output
P1.7/CA1	60	B12	I/O	General-purpose digital I/O Comparator_A input
P1.6/CA0	61	A11	I/O	General-purpose digital I/O Comparator_A input
P1.5/TACLK/ACLK	62	B10	I/O	General-purpose digital I/O Timer_A, clock signal TACLK input ACLK output (divided by 1, 2, 4, or 8)
P1.4/TBCLK/SMCLK	63	E9	I/O	General-purpose digital I/O Input clock TBCLK—Timer_B3 Submain system clock SMCLK output
P1.3/TBOUTH/SVSOUT	64	A10	I/O	General-purpose digital I/O Switch all PWM digital output ports to high impedance—Timer_B3 TB0 to TB2 SVS: output of SVS comparator
P1.2/TA1	65	B9	I/O	General-purpose digital I/O Timer_A, Capture: CCI1A, compare: Out1 output
P1.1/TA0/MCLK	66	D9	I/O	General-purpose digital I/O Timer_A. Capture: CCI0B / MCLK output. Note: TA0 is only an input on this pin BSL receive
P1.0/TA0	67	D8	I/O	General-purpose digital I/O Timer_A. Capture: CCI0A input, compare: Out0 output BSL transmit
XT2OUT	68	A8	O	Output terminal of crystal oscillator XT2
XT2IN	69	A7	I	Input port for crystal oscillator XT2. Only standard crystals can be connected.
TDO/TDI	70	D7	I/O	Test data output port. TDO/TDI data output or programming data input terminal
TDI/TCLK	71	E7	I	Test data input or test clock input. The device protection fuse is connected to TDI/ TCLK.
TMS	72	D6	I	Test mode select. TMS is used as an input port for device programming and test.
TCK	73	E6	I	Test clock. TCK is the clock input port for device programming and test.
RST/NMI	74	A6	I	Reset or nonmaskable interrupt input
P6.0/A0/OA0I0	75	A5	I/O	General-purpose digital I/O Analog input a0 – 12-bit ADC OA0 input multiplexer on +terminal and –terminal

TERMINAL			I/O	DESCRIPTION
NAME	NO.			
	PN	ZCA		
P6.1/A1/OA00	76	A4	I/O	General-purpose digital I/O Analog input a1 – 12-bit ADC OA0 output
P6.2/A2/OA011	77	B4	I/O	General-purpose digital I/O Analog input a2 – 12-bit ADC OA0 input multiplexer on + terminal and – terminal
AVSS	78	A2, D1, E2, F2, G2, G1, H2, J2		Analog supply voltage, negative terminal. Supplies SVS, brownout, oscillator, comparator_A, port 1, and LCD resistive divider circuitry.
DVSS1	79	A1, B2, C3, B6, B7, B8, A9		Digital supply voltage, negative terminal
AVCC	80	A3, B3		Analog supply voltage, positive terminal. Supplies SVS, brownout, oscillator, comparator_A, port 1, and LCD resistive divider circuitry; must not power up prior to DVCC1/DVCC2.
Reserved		(1)		Reserved

(1) A12, B11, E5, E8, F5, F8, F9, G5, G8, G9, H5, H6, H7, H8, H9, L11, M1, M12 are reserved and should be connected to ground.

## 8 Specifications

### 8.1 Absolute Maximum Ratings

over operating free-air temperature range (unless otherwise noted)

(1)	MIN	MAX	UNIT
Voltage applied at $V_{CC}$ to $V_{SS}$	-0.3	4.1	V
Voltage applied to any pin <sup>(2)</sup>	-0.3	$V_{CC} + 0.3$	V
Diode current at any device terminal		$\pm 2$	mA

- (1) Stresses beyond those listed under "absolute maximum ratings" may cause permanent damage to the device. These are stress ratings only, and functional operation of the device at these or any other conditions beyond those indicated under "recommended operating conditions" is not implied. Exposure to absolute-maximum-rated conditions for extended periods may affect device reliability.
- (2) All voltages referenced to  $V_{SS}$ . The JTAG fuse-blow voltage,  $V_{FB}$ , is allowed to exceed the absolute maximum rating. The voltage is applied to the TDI/TCLK pin when blowing the JTAG fuse.

### 8.2 Handling Ratings

		MIN	MAX	UNIT	
$T_{stg}$	Storage temperature range	Unprogrammed device	-55	150	°C
		Programmed device	-40	85	

### 8.3 Recommended Operating Conditions

			MIN	NOM	MAX	UNIT	
$V_{CC}$	Supply voltage <sup>(1)</sup> ( $AV_{CC} = DV_{CC1} = DV_{CC2} = V_{CC}$ )	During program execution	1.8		3.6	V	
		During program execution, SVS enabled and PORON = 1 <sup>(2)</sup>	2		3.6		
		During flash memory programming	2.7		3.6		
$V_{SS}$	Supply voltage <sup>(1)</sup> ( $AV_{SS} = DV_{SS1} = DV_{SS2} = V_{SS}$ )		0		0	V	
$T_A$	Operating free-air temperature range		-40		85	°C	
$f_{(LFXT1)}$	XT1 crystal frequency <sup>(3)</sup>	LF selected, XTS_FLL = 0	Watch crystal		32.768	kHz	
		XT1 selected, XTS_FLL = 1	Ceramic resonator		450		8000
		XT1 selected, XTS_FLL = 1	Crystal		1000		8000
$f_{(XT2)}$	XT2 crystal frequency	Ceramic resonator		450	8000	kHz	
		Crystal		1000	8000		
$f_{(System)}$	Processor frequency (signal MCLK)	$V_{CC} = 1.8\text{ V}$	dc		4.15	MHz	
		$V_{CC} = 3.6\text{ V}$	dc		8		

- (1) It is recommended to power  $AV_{CC}$  and  $DV_{CC}$  from the same source. A maximum difference of 0.3 V between  $AV_{CC}$  and  $DV_{CC}$  can be tolerated during power up and operation.
- (2) The minimum operating supply voltage is defined according to the trip point where POR is going active by decreasing the supply voltage. POR is going inactive when the supply voltage is raised above the minimum supply voltage plus the hysteresis of the SVS circuitry.
- (3) In LF mode, the LFXT1 oscillator requires a watch crystal. In XT1 mode, LFXT1 accepts a ceramic resonator or a crystal.

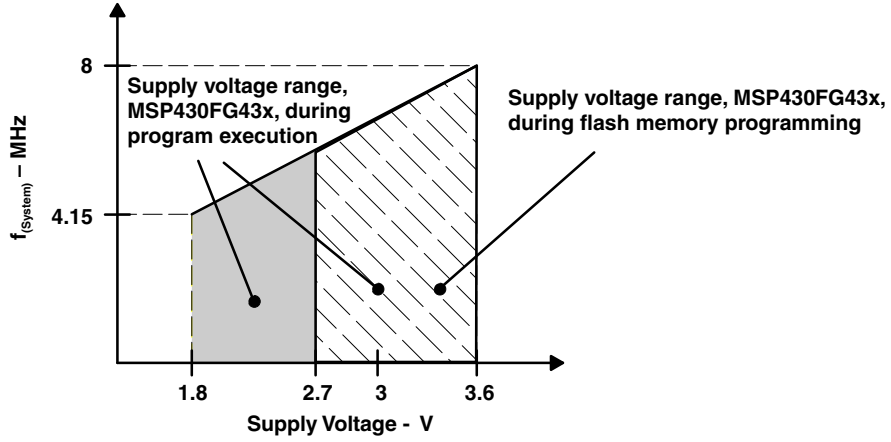

**Figure 8-1. Frequency vs Supply Voltage, Typical Characteristic**

## 8.4 Supply Current Into AV<sub>CC</sub> + DV<sub>CC</sub> Excluding External Current

over recommended operating free-air temperature (unless otherwise noted)

PARAMETER		T <sub>A</sub>	V <sub>CC</sub>	MIN	TYP	MAX	UNIT
I <sub>(AM)</sub>	Active mode <sup>(1)</sup> f <sub>(MCLK)</sub> = f <sub>(SMCLK)</sub> = 1 MHz, f <sub>(ACLK)</sub> = 32768 Hz, XTS_FLL = 0, SELM = (0,1)	–40°C to 85°C	2.2 V		300	370	μA
			3 V		470	570	
I <sub>(LPM0)</sub>	Low-power mode (LPM0) <sup>(1) (2)</sup>	–40°C to 85°C	2.2 V		55	70	μA
			3 V		95	150	
I <sub>(LPM2)</sub>	Low-power mode (LPM2), f <sub>(MCLK)</sub> = f <sub>(SMCLK)</sub> = 0 MHz, f <sub>(ACLK)</sub> = 32768 Hz, SCG0 = 0 <sup>(3) (2)</sup>	–40°C to 85°C	2.2 V		11	14	μA
			3 V		17	22	
I <sub>(LPM3)</sub>	Low-power mode (LPM3) f <sub>(MCLK)</sub> = f <sub>(SMCLK)</sub> = 0 MHz, f <sub>(ACLK)</sub> = 32768 Hz, SCG0 = 1 <sup>(3) (4) (2)</sup>	–40°C	2.2 V		1	2	μA
		25°C			1.1	2	
		60°C			2	3	
		85°C			3.5	6	
		–40°C	3 V		1.8	2.8	
		25°C			1.6	2.7	
		60°C			2.5	3.5	
		85°C			4.2	7.5	
I <sub>(LPM4)</sub>	Low-power mode (LPM4) f <sub>(MCLK)</sub> = f <sub>(SMCLK)</sub> = 0 MHz, f <sub>(ACLK)</sub> = 0 Hz, SCG0 = 1 <sup>(3) (2)</sup>	–40°C	2.2 V		0.1	0.5	μA
		25°C			0.1	0.5	
		60°C			0.7	1.1	
		85°C			1.7	3	
		–40°C	3 V		0.1	0.8	
		25°C			0.1	0.8	
		60°C			0.8	1.2	
		85°C			1.9	3.5	

(1) Timer\_B is clocked by f<sub>(DCOCLK)</sub> = f<sub>(DCO)</sub> = 1 MHz. All inputs are tied to 0 V or to V<sub>CC</sub>. Outputs do not source or sink any current.

(2) Current for brownout included.

(3) All inputs are tied to 0 V or to V<sub>CC</sub>. Outputs do not source or sink any current.

(4) The current consumption in LPM3 is measured with active Basic Timer1 and LCD (ACLK selected). The current consumption of the Comparator\_A and the SVS module are specified in the respective sections. The LPM3 currents are characterized with a KDS Daishinku DT–38 (6 pF) crystal and OSCCAPx = 01h.

Current consumption of active mode versus system frequency:

$$I_{(AM)} = I_{(AM)} [1 \text{ MHz}] \times f_{(\text{System})} [\text{MHz}]$$

Current consumption of active mode versus supply voltage:

$$I_{(AM)} = I_{(AM)} [3 \text{ V}] + 175 \mu\text{A/V} \times (V_{CC} - 3 \text{ V})$$

## 8.5 Schmitt-Trigger Inputs – Ports P1 to P6, $\overline{\text{RST}}$ /NMI, JTAG (TCK, TMS, TDI/TCLK, TDO/TDI)

over recommended operating free-air temperature range (unless otherwise noted)

PARAMETER		V <sub>CC</sub>	MIN	MAX	UNIT
V <sub>IT+</sub>	Positive-going input threshold voltage	2.2 V	1.1	1.55	V
		3 V	1.5	1.98	
V <sub>IT-</sub>	Negative-going input threshold voltage	2.2 V	0.4	0.9	V
		3 V	0.9	1.3	
V <sub>hys</sub>	Input voltage hysteresis (V <sub>IT+</sub> – V <sub>IT-</sub> )	2.2 V	0.3	1.1	V
		3 V	0.5	1	

## 8.6 Inputs P<sub>x.y</sub>, TAx, TBx

over recommended operating free-air temperature range (unless otherwise noted)

PARAMETER		TEST CONDITIONS	V <sub>CC</sub>	MIN	MAX	UNIT
t <sub>(int)</sub>	External interrupt timing	Port P1, P2: P1.x to P2.x, external trigger signal for the interrupt flag <sup>(1)</sup>	2.2 V	62		ns
			3 V	50		
t <sub>(cap)</sub>	Timer_A or Timer_B capture timing	TA0, TA1, TA2 TB0, TB1, TB2	2.2 V	62		ns
			3 V	50		
f <sub>(TAext)</sub>	Timer_A or Timer_B clock frequency externally applied to pin	TACLK, TBCLK, INCLK: t <sub>(H)</sub> = t <sub>(L)</sub>	2.2 V		8	MHz
f <sub>(TBext)</sub>			3 V		10	
f <sub>(TAint)</sub>	Timer_A or Timer_B clock frequency	SMCLK or ACLK signal selected	2.2 V		8	MHz
f <sub>(TBint)</sub>			3 V		10	

(1) The external signal sets the interrupt flag every time the minimum t<sub>(int)</sub> parameters are met. It might be set with trigger signals shorter than t<sub>(int)</sub>.

## 8.7 Leakage Current – Ports P1 to P6

over recommended operating free-air temperature range (unless otherwise noted)

PARAMETER <sup>(1)</sup>		TEST CONDITIONS		MIN	MAX	UNIT
I <sub>lkg(Px.y)</sub>	Leakage current, Port Px	V(Px.y) <sup>(2)</sup>	V <sub>CC</sub> = 2.2 V, 3 V		±50	nA

(1) The leakage current is measured with V<sub>SS</sub> or V<sub>CC</sub> applied to the corresponding pins, unless otherwise noted.

(2) The port pin must be selected as input.

## 8.8 Outputs – Ports P1 to P6

over recommended operating free-air temperature range (unless otherwise noted)

PARAMETER		TEST CONDITIONS	MIN	MAX	UNIT
V <sub>OH</sub>	High-level output voltage	I <sub>OH(max)</sub> = –1.5 mA, V <sub>CC</sub> = 2.2 V <sup>(1)</sup>	V <sub>CC</sub> – 0.25	V <sub>CC</sub>	V
		I <sub>OH(max)</sub> = –6 mA, V <sub>CC</sub> = 2.2 V <sup>(2)</sup>	V <sub>CC</sub> – 0.6	V <sub>CC</sub>	
		I <sub>OH(max)</sub> = –1.5 mA, V <sub>CC</sub> = 3 V <sup>(1)</sup>	V <sub>CC</sub> – 0.25	V <sub>CC</sub>	
		I <sub>OH(max)</sub> = –6 mA, V <sub>CC</sub> = 3 V <sup>(2)</sup>	V <sub>CC</sub> – 0.6	V <sub>CC</sub>	
V <sub>OL</sub>	Low-level output voltage	I <sub>OL(max)</sub> = 1.5 mA, V <sub>CC</sub> = 2.2 V <sup>(1)</sup>	V <sub>SS</sub>	V <sub>SS</sub> + 0.25	V
		I <sub>OL(max)</sub> = 6 mA, V <sub>CC</sub> = 2.2 V <sup>(2)</sup>	V <sub>SS</sub>	V <sub>SS</sub> + 0.6	
		I <sub>OL(max)</sub> = 1.5 mA, V <sub>CC</sub> = 3 V <sup>(1)</sup>	V <sub>SS</sub>	V <sub>SS</sub> + 0.25	
		I <sub>OL(max)</sub> = 6 mA, V <sub>CC</sub> = 3 V <sup>(2)</sup>	V <sub>SS</sub>	V <sub>SS</sub> + 0.6	

- (1) The maximum total current, I<sub>OH(max)</sub> and I<sub>OL(max)</sub>, for all outputs combined, should not exceed ±12 mA to satisfy the maximum specified voltage drop.
- (2) The maximum total current, I<sub>OH(max)</sub> and I<sub>OL(max)</sub>, for all outputs combined, should not exceed ±48 mA to satisfy the maximum specified voltage drop.

## 8.9 Output Frequency

over recommended operating free-air temperature range (unless otherwise noted)

PARAMETER		TEST CONDITIONS	MIN	TYP	MAX	UNIT
f <sub>(Px.y)</sub>	(1 ≤ x ≤ 6, 0 ≤ y ≤ 7)	C <sub>L</sub> = 20 F, I <sub>L</sub> = ±1.5 mA	V <sub>CC</sub> = 2.2 V, 3 V	dc	f <sub>(System)</sub>	MHz
f <sub>(MCLK)</sub>	P1.1/TA0/MCLK	C <sub>L</sub> = 20 pF			f <sub>(System)</sub>	MHz
f <sub>(SMCLK)</sub>	P1.4/TBCLK/SMCLK					
f <sub>(ACLK)</sub>	P1.5/TACLK/ACLK					
t <sub>(Xdc)</sub>	Duty cycle of output frequency	P1.5/TACLK/ACLK, C <sub>L</sub> = 20 pF, V <sub>CC</sub> = 2.2 V, 3 V	f <sub>(ACLK)</sub> = f <sub>(LFXT1)</sub> = f <sub>(XT1)</sub>	40%	60%	
			f <sub>(ACLK)</sub> = f <sub>(LFXT1)</sub> = f <sub>(LF)</sub>	30%	70%	
			f <sub>(ACLK)</sub> = f <sub>(LFXT1)</sub>	50%		
		P1.1/TA0/MCLK, C <sub>L</sub> = 20 pF, V <sub>CC</sub> = 2.2 V, 3 V	f <sub>(MCLK)</sub> = f <sub>(XT1)</sub>	40%	60%	
			f <sub>(MCLK)</sub> = f <sub>(DCOCLK)</sub>	50% – 15 ns	50%	50%+ 15 ns
		P1.4/TBCLK/SMCLK, C <sub>L</sub> = 20 pF, V <sub>CC</sub> = 2.2 V, 3 V	f <sub>(SMCLK)</sub> = f <sub>(XT2)</sub>	40%	60%	
f <sub>(SMCLK)</sub> = f <sub>(DCOCLK)</sub>	50% – 15 ns		50%	50%+ 15 ns		

## 8.10 Typical Characteristics – Outputs

over recommended ranges of supply voltage and operating free-air temperature (unless otherwise noted)

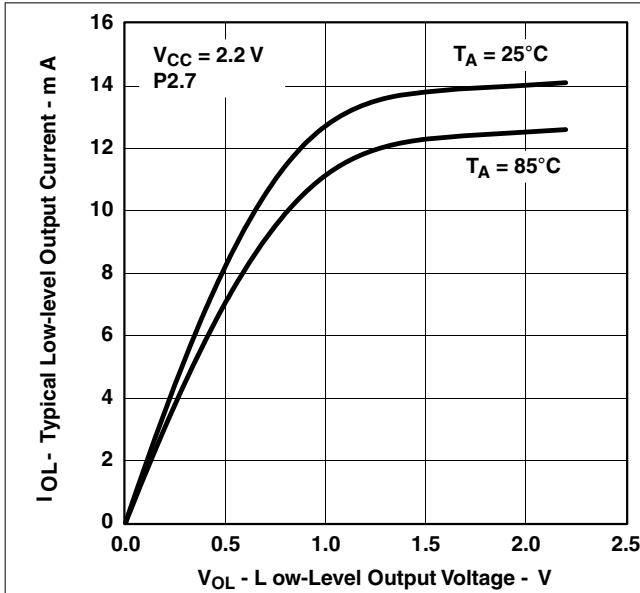

Figure 8-2. Typical Low-Level Output Current vs Typical Low-Level Output Current

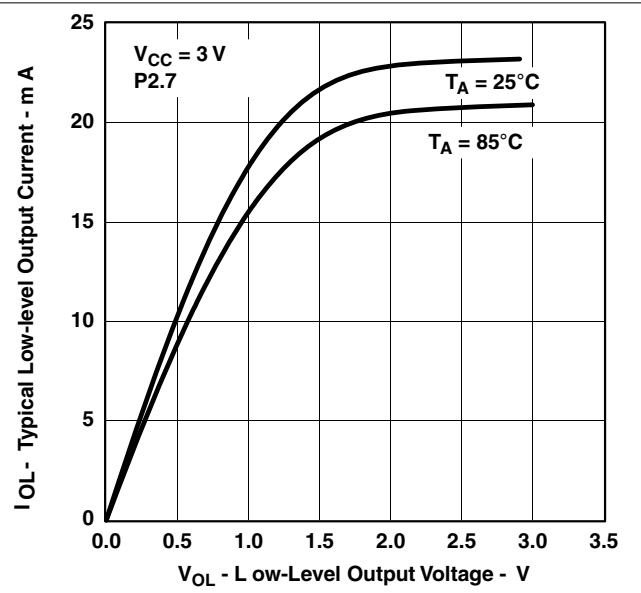

Figure 8-3. Typical Low-Level Output Current vs Typical Low-Level Output Current

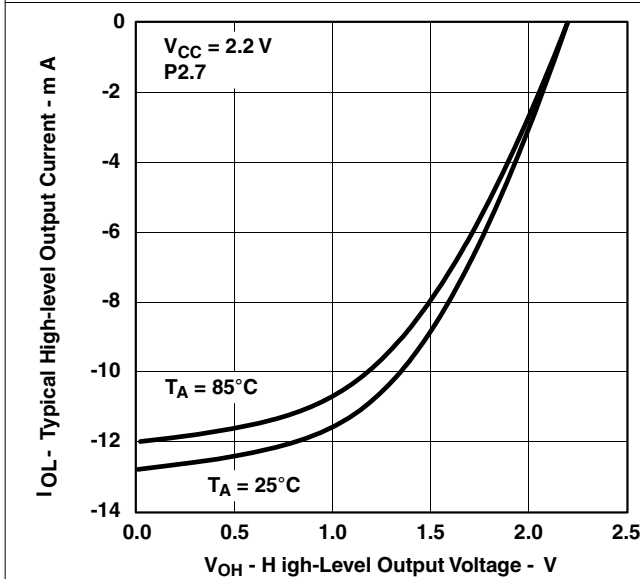

Figure 8-4. Typical High-Level Output Current vs Typical High-Level Output Current

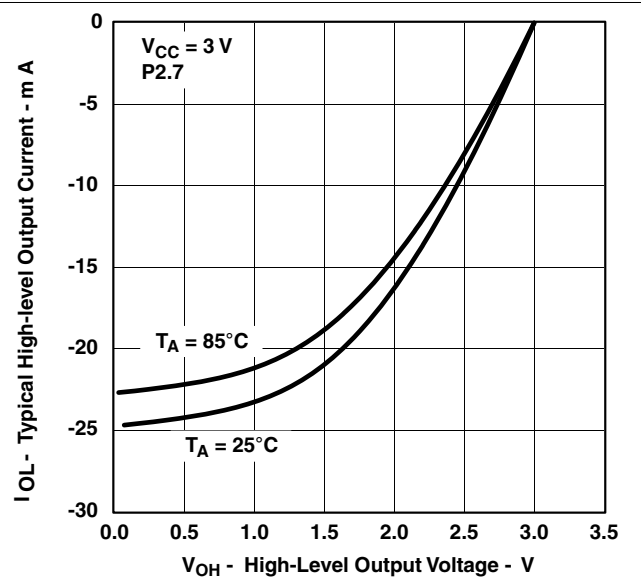

Figure 8-5. Typical High-Level Output Current vs Typical High-Level Output Current

## 8.11 Wake-Up From LPM3

over recommended operating free-air temperature range (unless otherwise noted)

PARAMETER		TEST CONDITIONS		MIN	MAX	UNIT
$t_{d(LPM3)}$	Delay time	f = 1 MHz	$V_{CC} = 2.2\text{ V}, 3\text{ V}$		6	$\mu\text{s}$
		f = 2 MHz		6		
		f = 3 MHz		6		

## 8.12 RAM

over recommended operating free-air temperature range (unless otherwise noted)

PARAMETER	TEST CONDITIONS	MIN	MAX	UNIT
$V_{RAMh}$	CPU halted <sup>(1)</sup>	1.6		V

(1) This parameter defines the minimum supply voltage when the data in program memory RAM remain unchanged. No program execution should take place during this supply voltage condition.

## 8.13 LCD

over recommended operating free-air temperature range (unless otherwise noted)

PARAMETER		TEST CONDITIONS		MIN	TYP	MAX	UNIT
$V_{(33)}$	Analog voltage	Voltage at P5.7/R33	$V_{CC} = 3\text{ V}$	2.5		$V_{CC} + 0.2$	V
$V_{(23)}$		Voltage at P5.6/R23		$[V_{(33)} - V_{(03)}] \times 2/3 + V_{(03)}$			
$V_{(13)}$		Voltage at P5.5/R13		$[V_{(33)} - V_{(03)}] \times 1/3 + V_{(03)}$			
$V_{(33)} - V_{(03)}$		Voltage at R33 to R03		2.5	$V_{CC} + 0.2$		
$I_{(R03)}$	Input leakage	$R03 = V_{SS}$	No load at all segment and common lines, $V_{CC} = 3\text{ V}$			$\pm 20$	nA
$I_{(R13)}$		$P5.5/R13 = V_{CC}/3$				$\pm 20$	
$I_{(R23)}$		$P5.6/R23 = 2 \times V_{CC}/3$				$\pm 20$	
$V_{(Sxx0)}$	Segment line voltage	$I_{(Sxx)} = -3\ \mu\text{A}, V_{CC} = 3\text{ V}$		$V_{(03)}$		$V_{(03)} - 1$	V
$V_{(Sxx1)}$				$V_{(13)}$		$V_{(13)} - 1$	
$V_{(Sxx2)}$				$V_{(23)}$		$V_{(23)} - 1$	
$V_{(Sxx3)}$				$V_{(33)}$		$V_{(33)} - 1$	

### 8.14 Comparator\_A

over recommended operating free-air temperature range (unless otherwise noted)

PARAMETER <sup>(1)</sup>		TEST CONDITIONS	V <sub>CC</sub>	MIN	TYP	MAX	UNIT
I <sub>(CC)</sub>		CAON = 1, CARSEL = 0, CAREF = 0	2.2 V	25	50		μA
			3 V	45	60		
I <sub>(Refladder/RefDiode)</sub>		CAON = 1, CARSEL = 0, CAREF = (1,2,3), No load at P1.6/CA0 and P1.7/CA1	2.2 V	30	50		μA
			3 V	45	71		
V <sub>(Ref025)</sub>	(Voltage at 0.25 V <sub>CC</sub> node) / V <sub>CC</sub>	PCA0 = 1, CARSEL = 1, CAREF = 1, No load at P1.6/CA0 and P1.7/CA1	2.2 V, 3 V	0.23	0.24	0.25	
V <sub>(Ref050)</sub>	(Voltage at 0.55 V <sub>CC</sub> node) / V <sub>CC</sub>	PCA0 = 1, CARSEL = 1, CAREF = 2, No load at P1.6/CA0 and P1.7/CA1	2.2 V, 3 V	0.47	0.48	0.5	
V <sub>(RefVT)</sub>	See Figure 8-6 and Figure 8-7	PCA0 = 1, CARSEL = 1, CAREF = 3, No load at P1.6/CA0 and P1.7/CA1, T <sub>A</sub> = 85°C	2.2 V	390	480	540	mV
			3 V	400	490	550	
V <sub>IC</sub>	Common-mode input voltage range	CAON = 1	2.2 V, 3 V	0		V <sub>CC</sub> - 1	V
V <sub>p</sub> - V <sub>s</sub>	Offset voltage	See <sup>(2)</sup>	2.2 V, 3 V	-30		30	mV
V <sub>hys</sub>	Input hysteresis	CAON = 1	2.2 V, 3 V	0	0.7	1.4	mV
t <sub>(response LH)</sub>		T <sub>A</sub> = 25°C, Overdrive 10 mV, without filter: CAF = 0	2.2 V	160	210	300	ns
			3 V	80	150	240	
		T <sub>A</sub> = 25°C, Overdrive 10 mV, with filter: CAF = 1	2.2 V	1.4	1.9	3.4	μs
			3 V	0.9	1.5	2.6	
t <sub>(response HL)</sub>		T <sub>A</sub> = 25°C, Overdrive 10 mV, without filter: CAF = 0	2.2 V	130	210	300	ns
			3 V	80	150	240	
		T <sub>A</sub> = 25°C, Overdrive 10 mV, with filter: CAF = 1	2.2 V	1.4	1.9	3.4	μs
			3 V	0.9	1.5	2.6	

- (1) The leakage current for the Comparator\_A terminals is identical to I<sub>lkg(Px,y)</sub> specification.
- (2) The input offset voltage can be cancelled by using the CAEX bit to invert the Comparator\_A inputs on successive measurements. The two successive measurements are then summed together.

### 8.15 Comparator\_A Typical Characteristics

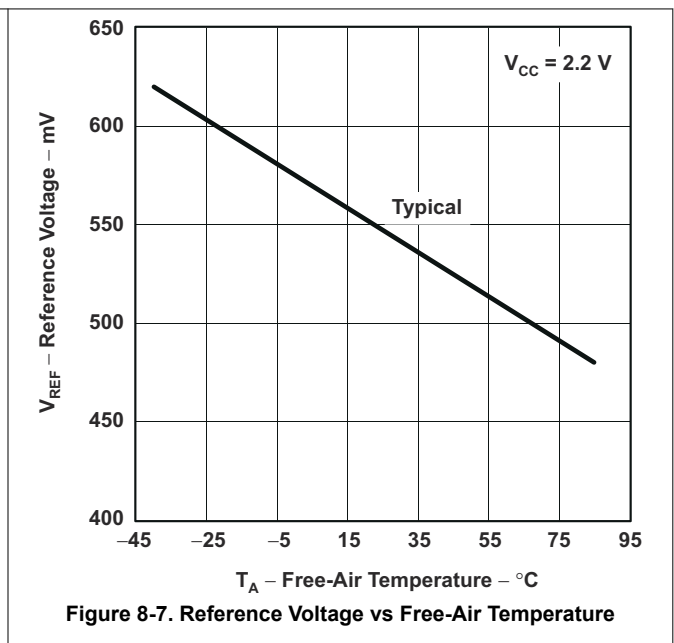
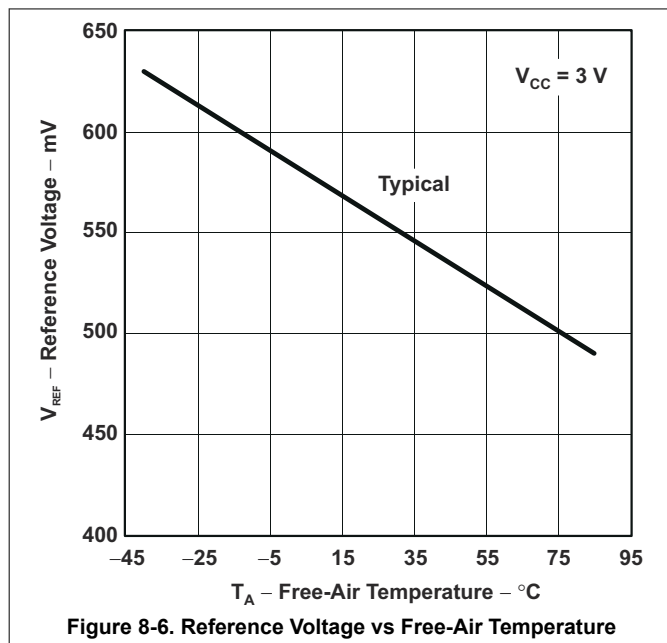

### 8.15 Comparator\_A Typical Characteristics (continued)

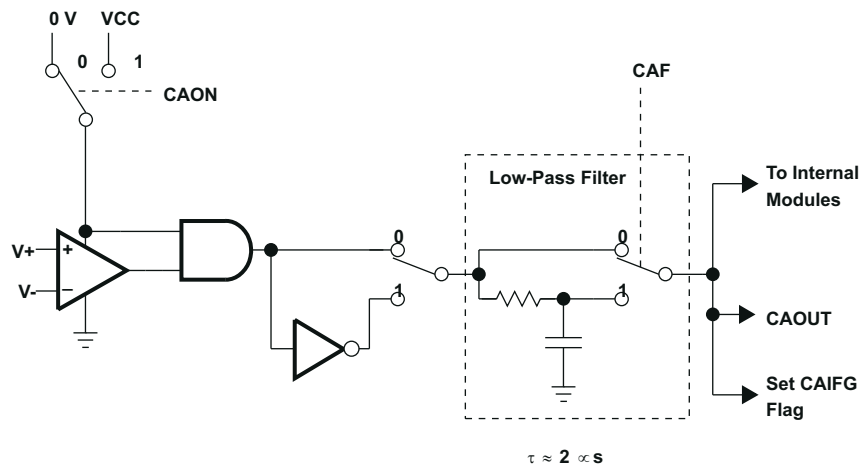

Figure 8-8. Block Diagram of Comparator\_A Module

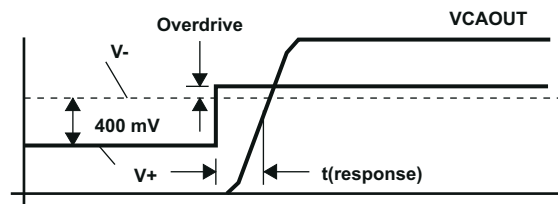

Figure 8-9. Overdrive Definition

### 8.16 Power-On Reset (POR) and Brownout Reset (BOR)

over recommended operating free-air temperature range (unless otherwise noted)

PARAMETER <sup>(1)</sup>	TEST CONDITIONS	MIN	TYP	MAX	UNIT
$t_{d(BOR)}$				2000	$\mu\text{s}$
$V_{CC(start)}$	$dV_{CC}/dt \leq 3 \text{ V/s}$ (see Figure 8-10)		$0.7 \times V_{(B\_IT-)}$		V
$V_{(B\_IT-)}$	$dV_{CC}/dt \leq 3 \text{ V/s}$ (see Figure 8-10 through Figure 8-12)		1.71		V
$V_{hys(B\_IT-)}$	$dV_{CC}/dt \leq 3 \text{ V/s}$ (see Figure 8-10)	70	130	210	mV
$t_{(reset)}$	Pulse length needed at RST/NMI pin to accepted reset internally, $V_{CC} = 2.2 \text{ V}, 3 \text{ V}$	2			$\mu\text{s}$

- (1) The current consumption of the brownout module is already included in the  $I_{CC}$  current consumption data. The voltage level  $V_{(B\_IT-)} + V_{hys(B\_IT-)}$  is  $\leq 1.8 \text{ V}$ .
- (2) During power up, the CPU begins code execution following a period of  $t_{d(BOR)}$  after  $V_{CC} = V_{(B\_IT-)} + V_{hys(B\_IT-)}$ . The default FLL+ settings must not be changed until  $V_{CC} \geq V_{CC(min)}$ , where  $V_{CC(min)}$  is the minimum supply voltage for the desired operating frequency. See the *MSP430x4xx Family User's Guide (SLAU056)* for more information on the brownout/SVS circuit.

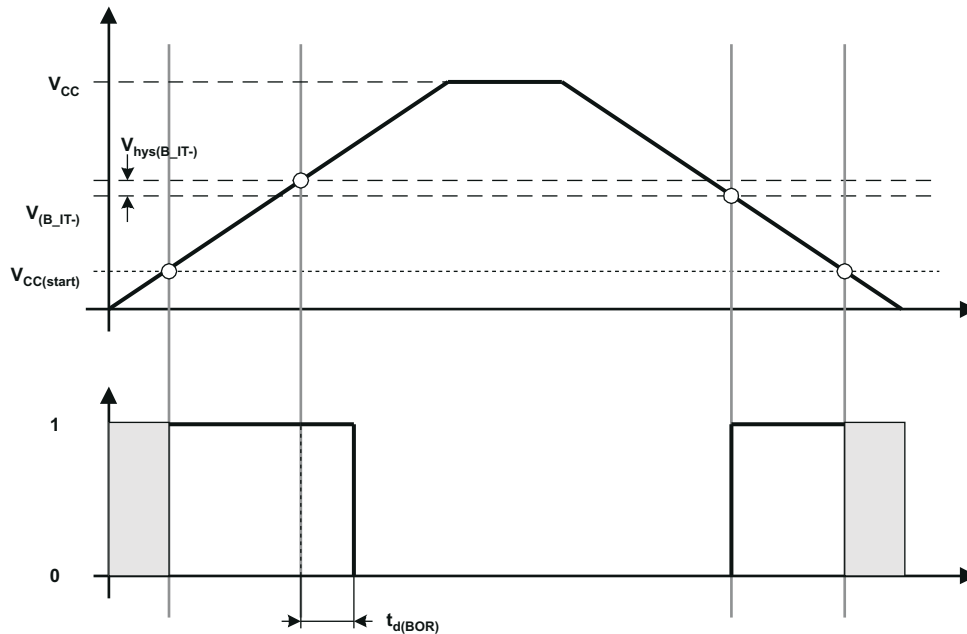

Figure 8-10. POR and BOR vs Supply Voltage

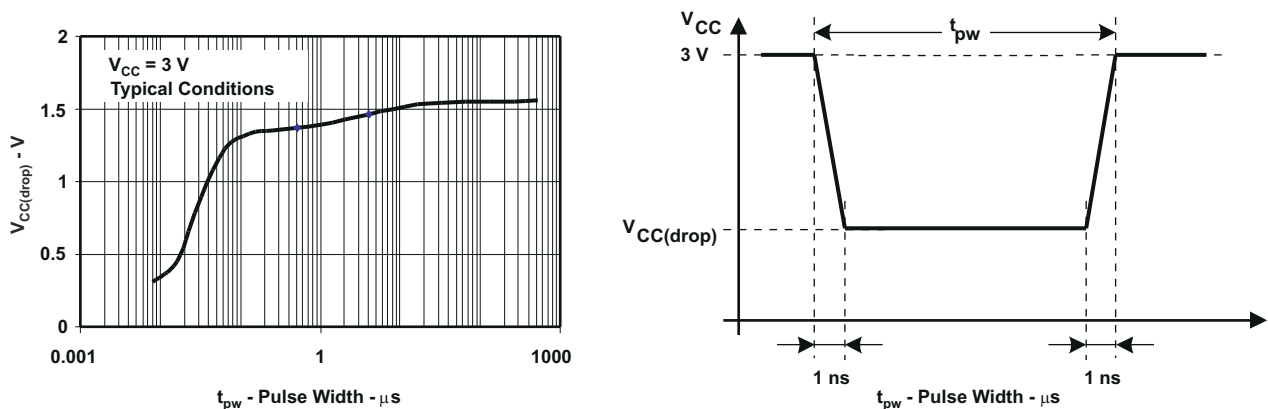

Figure 8-11.  $V_{CC(drop)}$  Level with a Square Voltage Drop to Generate a POR or BOR Signal

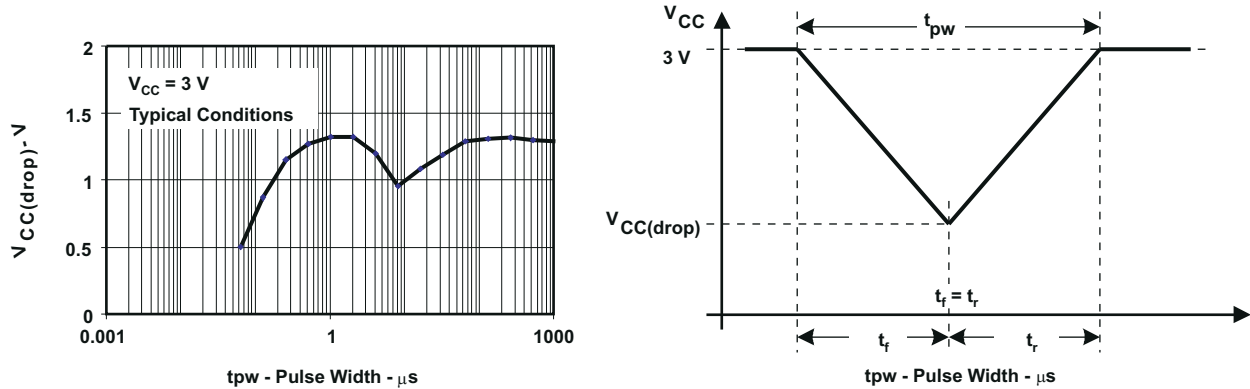

Figure 8-12.  $V_{CC(drop)}$  Level With a Triangle Voltage Drop to Generate a POR or BOR Signal

### 8.17 Supply Voltage Supervisor (SVS) and Supply Voltage Monitor (SVM)

over recommended operating free-air temperature range (unless otherwise noted)

PARAMETER	TEST CONDITIONS	MIN	TYP	MAX	UNIT	
$t_{(SVSR)}$	$dV_{CC}/dt > 30 \text{ V/ms}$ (see Figure 8-13)	5		150	$\mu\text{s}$	
	$dV_{CC}/dt \leq 30 \text{ V/ms}$			2000		
$t_{d(SVson)}$	SVS on, switch from VLD = 0 to VLD $\neq$ 0, $V_{CC} = 3 \text{ V}$		150	300	$\mu\text{s}$	
$t_{settle}$	VLD $\neq$ 0 <sup>(1)</sup>			12	$\mu\text{s}$	
$V_{(SVSstart)}$	VLD $\neq$ 0, $V_{CC}/dt \leq 3 \text{ V/s}$ (see Figure 8-13)		1.55	1.7	V	
$V_{hys(SVS\_IT-)}$	$V_{CC}/dt \leq 3 \text{ V/s}$ (see Figure 8-13)	VLD = 1	70	120	155	mV
		VLD = 2 to 14	$V_{(SVS\_IT-)} \times 0.001$		$V_{(SVS\_IT-)} \times 0.016$	
	$V_{CC}/dt \leq 3 \text{ V/s}$ (see Figure 8-13), external voltage applied on A7	VLD = 15	4.4		20	mV
$V_{(SVS\_IT-)}$	$V_{CC}/dt \leq 3 \text{ V/s}$ (see Figure 8-13)	VLD = 1	1.8	1.9	2.05	V
		VLD = 2	1.94	2.1	2.23	
		VLD = 3	2.05	2.2	2.35	
		VLD = 4	2.14	2.3	2.46	
		VLD = 5	2.24	2.4	2.58	
		VLD = 6	2.33	2.5	2.69	
		VLD = 7	2.46	2.65	2.84	
		VLD = 8	2.58	2.8	2.97	
		VLD = 9	2.69	2.9	3.10	
		VLD = 10	2.83	3.05	3.26	
		VLD = 11	2.94	3.2	3.39	
		VLD = 12	3.11	3.35	3.58 <sup>(2)</sup>	
		VLD = 13	3.24	3.5	3.73 <sup>(2)</sup>	
		VLD = 14	3.43	3.7 <sup>(2)</sup>	3.96 <sup>(2)</sup>	
	$V_{CC}/dt \leq 3 \text{ V/s}$ (see Figure 8-13), external voltage applied on A7	VLD = 15	1.1	1.2	1.3	
$I_{CC(SVS)}$ <sup>(3)</sup>	VLD $\neq$ 0, $V_{CC} = 2.2 \text{ V}, 3 \text{ V}$		10	15	$\mu\text{A}$	

- (1)  $t_{settle}$  is the settling time that the comparator output needs to have a stable level after VLD is switched from VLD  $\neq$  0 to a different VLD value somewhere between 2 and 15. The overdrive is assumed to be  $> 50 \text{ mV}$ .
- (2) The recommended operating voltage range is limited to 3.6 V.
- (3) The current consumption of the SVS module is not included in the  $I_{CC}$  current consumption data.

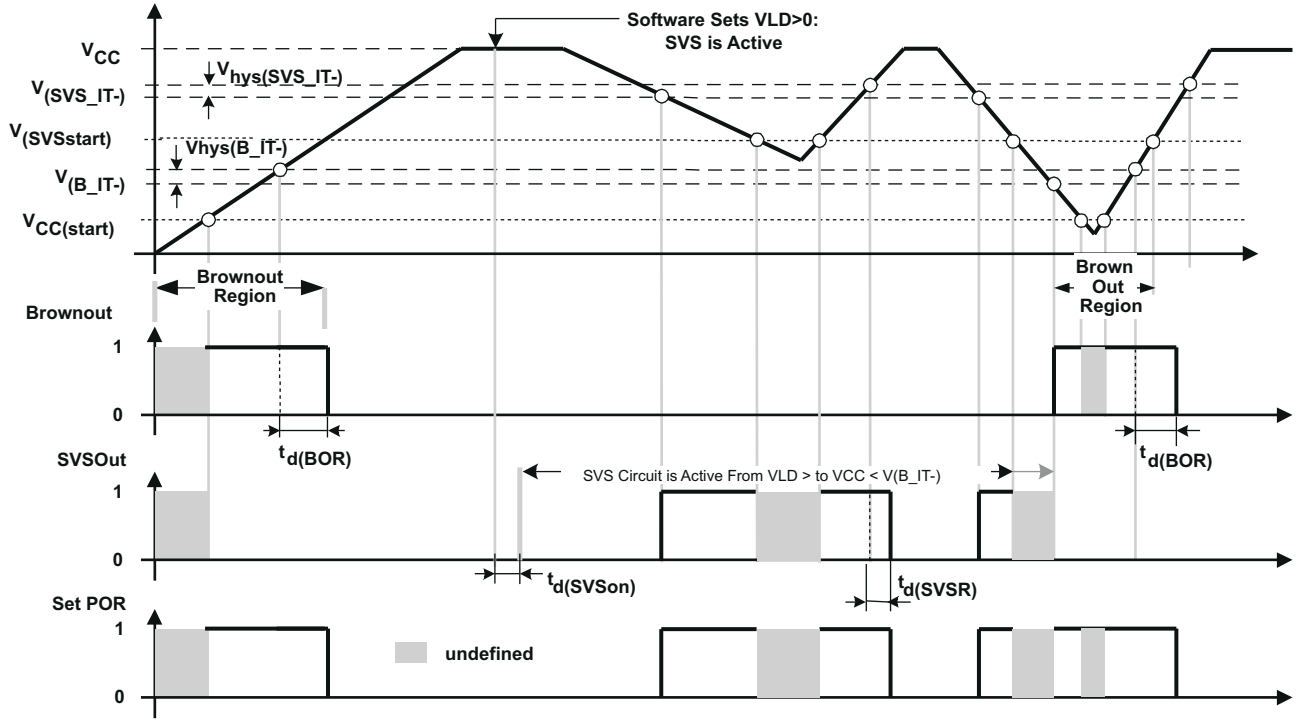

Figure 8-13. SVS Reset (SVSR) vs Supply Voltage

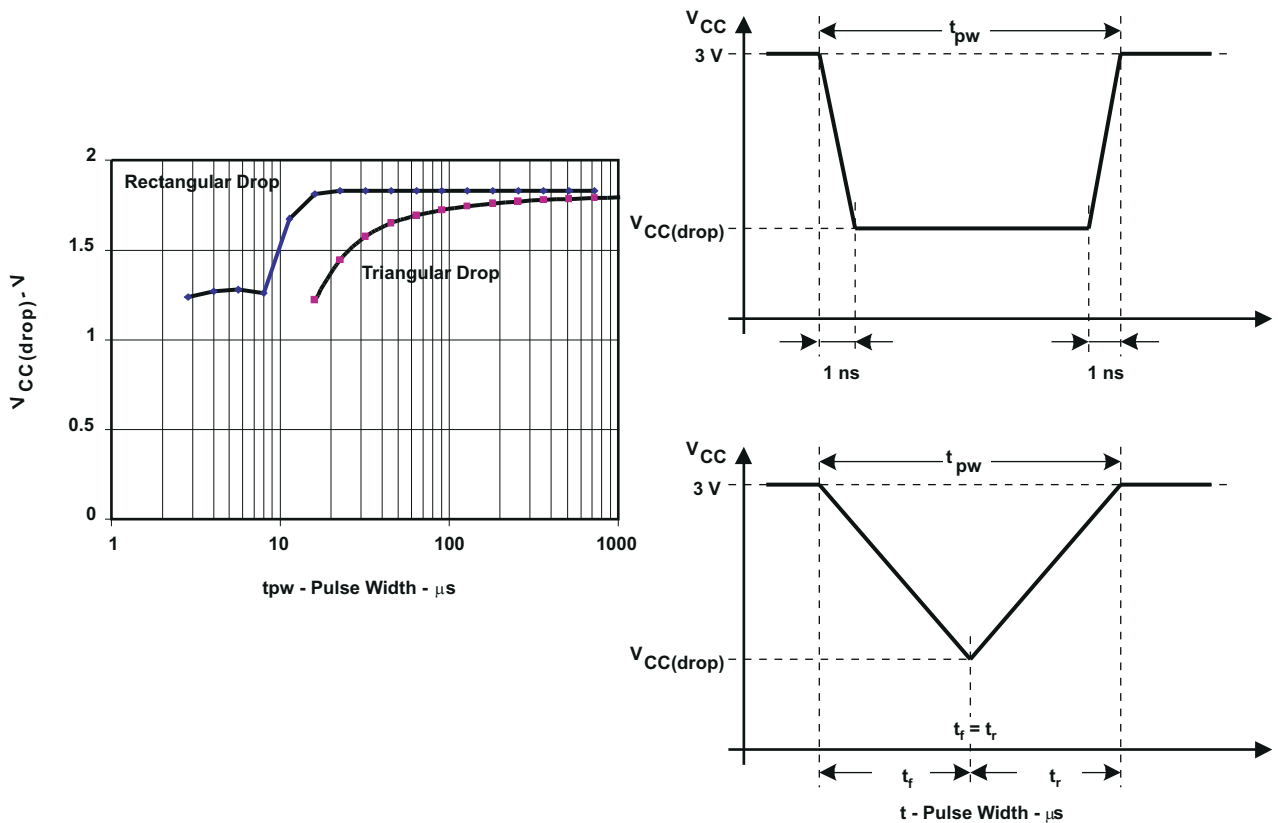

Figure 8-14.  $V_{CC(drop)}$  With a Square Voltage Drop and a Triangle Voltage Drop to Generate an SVS Signal

## 8.18 DCO

over recommended operating free-air temperature range (unless otherwise noted)

PARAMETER	TEST CONDITIONS	V <sub>CC</sub>	MIN	TYP	MAX	UNIT
f <sub>(DCOCLK)</sub>	N <sub>(DCO)</sub> = 01Eh, FN <sub>8</sub> = FN <sub>4</sub> = FN <sub>3</sub> = FN <sub>2</sub> = 0, D = 2, DCOPLUS = 0, f <sub>Crystal</sub> = 32.738 kHz	2.2 V, 3 V		1		MHz
f <sub>(DCO=2)</sub>	FN <sub>8</sub> =FN <sub>4</sub> = FN <sub>3</sub> = FN <sub>2</sub> = 0, DCOPLUS = 1	2.2 V	0.3	0.65	1.25	MHz
		3 V	0.3	0.7	1.3	
f <sub>(DCO=27)</sub>	FN <sub>8</sub> = FN <sub>4</sub> = FN <sub>3</sub> = FN <sub>2</sub> = 0, DCOPLUS = 1	2.2 V	2.5	5.6	10.5	MHz
		3 V	2.7	6.1	11.3	
f <sub>(DCO=2)</sub>	FN <sub>8</sub> = FN <sub>4</sub> = FN <sub>3</sub> = FN <sub>2</sub> = 1, DCOPLUS = 1	2.2 V	0.7	1.3	2.3	MHz
		3 V	0.8	1.5	2.5	
f <sub>(DCO=27)</sub>	FN <sub>8</sub> = FN <sub>4</sub> = FN <sub>3</sub> = FN <sub>2</sub> = 1, DCOPLUS = 1	2.2 V	5.7	10.8	18	MHz
		3 V	6.5	12.1	20	
f <sub>(DCO=2)</sub>	FN <sub>8</sub> = FN <sub>4</sub> = 0, FN <sub>3</sub> = 1, FN <sub>2</sub> = x, DCOPLUS = 1	2.2 V	1.2	2	3	MHz
		3 V	1.3	2.2	3.5	
f <sub>(DCO=27)</sub>	FN <sub>8</sub> = FN <sub>4</sub> = 0, FN <sub>3</sub> = 1, FN <sub>2</sub> = x, DCOPLUS = 1	2.2 V	9	15.5	25	MHz
		3 V	10.3	17.9	28.5	
f <sub>(DCO=2)</sub>	FN <sub>8</sub> = 0, FN <sub>4</sub> = 1, FN <sub>3</sub> = FN <sub>2</sub> = x, DCOPLUS = 1	2.2 V	1.8	2.8	4.2	MHz
		3 V	2.1	3.4	5.2	
f <sub>(DCO=27)</sub>	FN <sub>8</sub> = 0, FN <sub>4</sub> = 1, FN <sub>3</sub> = FN <sub>2</sub> = x, DCOPLUS = 1	2.2 V	13.5	21.5	33	MHz
		3 V	16	26.6	41	
f <sub>(DCO=2)</sub>	FN <sub>8</sub> = 1, FN <sub>4</sub> = FN <sub>3</sub> = FN <sub>2</sub> = x, DCOPLUS = 1	2.2 V	2.8	4.2	6.2	MHz
		3 V	4.2	6.3	9.2	
f <sub>(DCO=27)</sub>	FN <sub>8</sub> = 1, FN <sub>4</sub> = FN <sub>3</sub> = FN <sub>2</sub> = x, DCOPLUS = 1	2.2 V	21	32	46	MHz
		3 V	30	46	70	
S <sub>n</sub>	Step size between adjacent DCO taps: S <sub>n</sub> = f <sub>DCO(Tap n+1)</sub> / f <sub>DCO(Tap n)</sub> (see Figure 8-16 for taps 21 to 27)	1 < TAP ≤ 20	1.06		1.11	
		TAP = 27	1.07		1.17	
D <sub>t</sub>	Temperature drift, N <sub>(DCO)</sub> = 01Eh, FN <sub>8</sub> = FN <sub>4</sub> = FN <sub>3</sub> = FN <sub>2</sub> = 0, D = 2, DCOPLUS = 0	2.2 V	-0.2	-0.3	-0.4	%/ <sup>o</sup> C
		3 V	-0.2	-0.3	-0.4	
D <sub>V</sub>	Drift with V <sub>CC</sub> variation, N <sub>(DCO)</sub> = 01Eh, FN <sub>8</sub> = FN <sub>4</sub> = FN <sub>3</sub> = FN <sub>2</sub> = 0, D = 2, DCOPLUS = 0	2.2 V, 3 V	0	5	15	%/V

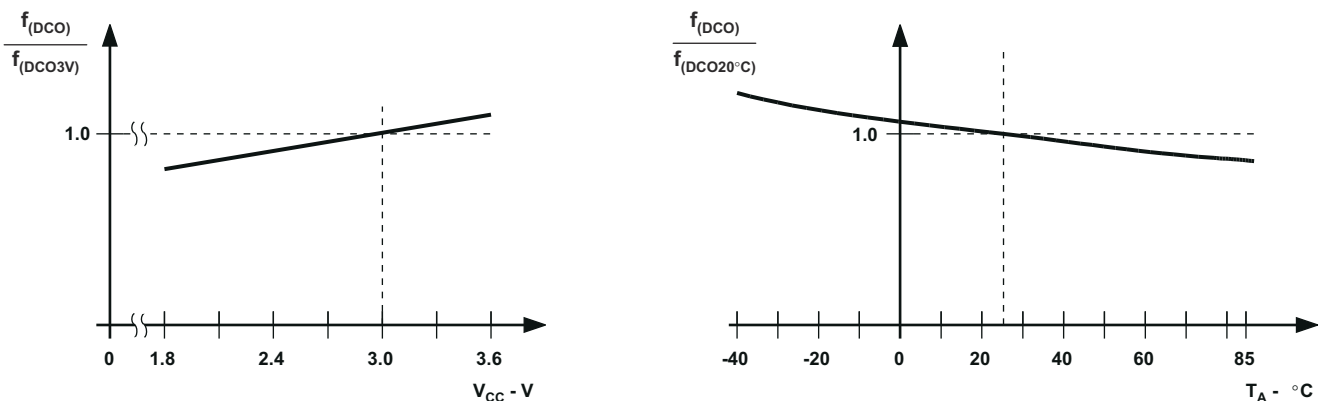

Figure 8-15. DCO Frequency vs Supply Voltage V<sub>CC</sub> and vs Ambient Temperature

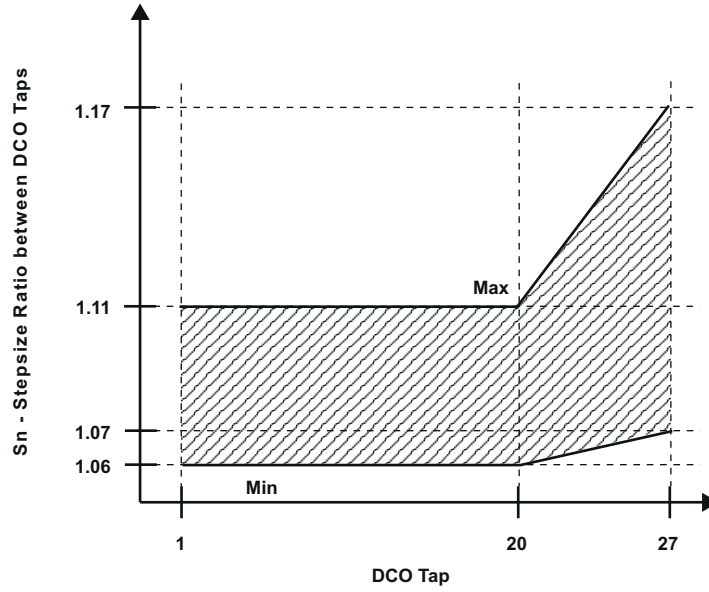

Figure 8-16. DCO Tap Step Size

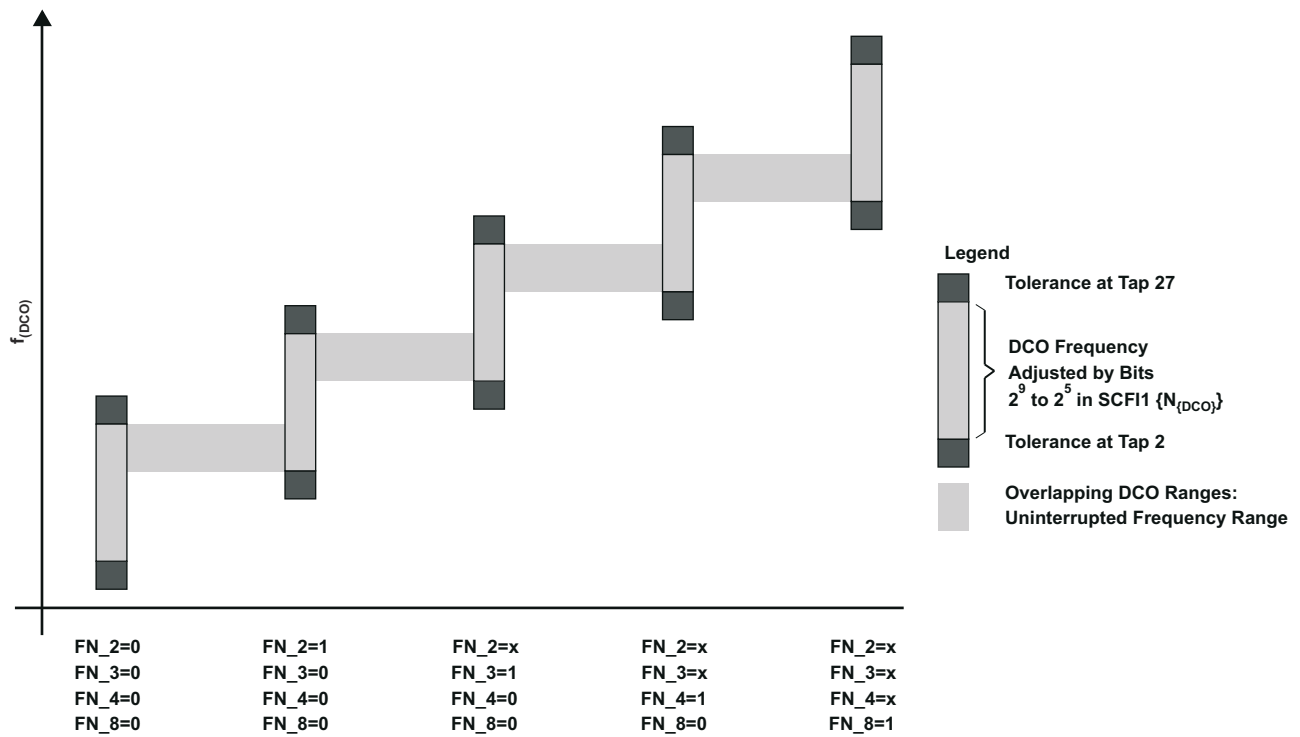

Figure 8-17. Five Overlapping DCO Ranges Controlled by FN\_x Bits

## 8.19 Crystal Oscillator, XT1 Oscillator

over recommended operating free-air temperature range (unless otherwise noted)

PARAMETER <sup>(1)</sup>		TEST CONDITIONS <sup>(2)</sup>	MIN	TYP	MAX	UNIT
C <sub>XIN</sub>	Integrated input capacitance <sup>(3)</sup>	OSCCAPx = 0h, V <sub>CC</sub> = 2.2 V, 3 V		0		pF
		OSCCAPx = 1h, V <sub>CC</sub> = 2.2 V, 3 V		10		
		OSCCAPx = 2h, V <sub>CC</sub> = 2.2 V, 3 V		14		
		OSCCAPx = 3h, V <sub>CC</sub> = 2.2 V, 3 V		18		
C <sub>XOUT</sub>	Integrated output capacitance <sup>(3)</sup>	OSCCAPx = 0h, V <sub>CC</sub> = 2.2 V, 3 V		0		pF
		OSCCAPx = 1h, V <sub>CC</sub> = 2.2 V, 3 V		10		
		OSCCAPx = 2h, V <sub>CC</sub> = 2.2 V, 3 V		14		
		OSCCAPx = 3h, V <sub>CC</sub> = 2.2 V, 3 V		18		
V <sub>IL</sub>	Input levels at XIN	V <sub>CC</sub> = 2.2 V, 3 V <sup>(4)</sup>	V <sub>SS</sub>	0.2 × V <sub>CC</sub>		V
V <sub>IH</sub>			0.8 × V <sub>CC</sub>	V <sub>CC</sub>		

- The parasitic capacitance from the package and board may be estimated to be 2 pF. The effective load capacitor for the crystal is (C<sub>XIN</sub> × C<sub>XOUT</sub>) / (C<sub>XIN</sub> + C<sub>XOUT</sub>). This is independent of XTS\_FLL.
- To improve EMI on the low-power LFXT1 oscillator, particularly in the LF mode (32 kHz), the following guidelines should be observed.
  - Keep the trace between the device and the crystal as short as possible.
  - Design a good ground plane around the oscillator pins.
  - Prevent crosstalk from other clock or data lines into oscillator pins XIN and XOUT.
  - Avoid running PCB traces underneath or adjacent to the XIN and XOUT pins.
  - Use assembly materials and processes that avoid any parasitic load on the oscillator XIN and XOUT pins.
  - If conformal coating is used, make sure that it does not induce capacitive or resistive leakage between the oscillator pins.
  - Do not route the XOUT line to the JTAG header to support the serial programming adapter as shown in other documentation. This signal is no longer required for the serial programming adapter.
- External capacitance is recommended for precision real-time clock applications, OSCCAPx = 0h.
- Applies only when using an external logic-level clock source. XTS\_FLL must be set. Not applicable when using a crystal or resonator.

## 8.20 Crystal Oscillator, XT2 Oscillator

over recommended operating free-air temperature range (unless otherwise noted)

PARAMETER <sup>(1)</sup>		TEST CONDITIONS	MIN	TYP	MAX	UNIT
C <sub>XT2IN</sub>	Integrated input capacitance	V <sub>CC</sub> = 2.2 V, 3 V		2		pF
C <sub>XT2OUT</sub>	Integrated output capacitance	V <sub>CC</sub> = 2.2 V, 3 V		2		pF
V <sub>IL</sub>	Input levels at XT2IN	V <sub>CC</sub> = 2.2 V, 3 V <sup>(2)</sup>	V <sub>SS</sub>	0.2 × V <sub>CC</sub>		V
V <sub>IH</sub>			0.8 × V <sub>CC</sub>	V <sub>CC</sub>		V

- The oscillator needs capacitors at both terminals, with values specified by the crystal manufacturer.
- Applies only when using an external logic-level clock source. Not applicable when using a crystal or resonator.

## 8.21 USART0

over recommended operating free-air temperature range (unless otherwise noted)

PARAMETER <sup>(1)</sup>		TEST CONDITIONS	MIN	TYP	MAX	UNIT
t <sub>(r)</sub>	USART0 deglitch time	V <sub>CC</sub> = 2.2 V, SYNC = 0, UART mode	200	430	800	ns
		V <sub>CC</sub> = 3 V, SYNC = 0, UART mode	150	280	500	

- The signal applied to the USART0 receive signal/terminal (URXD0) should meet the timing requirements of t<sub>(r)</sub> to ensure that the URXS flip-flop is set. The URXS flip-flop is set with negative pulses meeting the minimum timing condition of t<sub>(r)</sub>. The operating conditions to set the flag must be met independently from this timing constraint. The deglitch circuitry is active only on negative transitions on the URXD0 line.

## 8.22 12-Bit ADC, Power Supply and Input Range Conditions

over recommended operating free-air temperature range (unless otherwise noted)

PARAMETER <sup>(1)</sup>		TEST CONDITIONS	MIN	TYP	MAX	UNIT
$V_{CC}$	Analog supply voltage	$A_{V_{CC}}$ and $DV_{CC}$ are connected together, $A_{V_{SS}}$ and $DV_{SS}$ are connected together, $V_{(AVSS)} = V_{(DVSS)} = 0$ V	2.2		3.6	V
$V_{(P6.x/Ax)}$	Analog input voltage range <sup>(2)</sup>	All external $A_x$ terminals, Analog inputs selected in ADC12MCTLx register and P6Sel.x = 1, $V_{(AVSS)} \leq V_{Ax} \leq V_{(AVCC)}$	0		$V_{AVCC}$	V
$I_{ADC12}$	Operating supply current into the AVCC terminal <sup>(3)</sup>	$f_{ADC12CLK} = 5.0$ MHz, ADC12ON = 1, REFON = 0, SHT0 = 0, SHT1 = 0, ADC12DIV = 0	$V_{CC} = 2.2$ V	0.65	1.3	mA
			$V_{CC} = 3$ V	0.8	1.6	
$I_{REF+}$	Operating supply current into the AVCC terminal <sup>(4)</sup>	$f_{ADC12CLK} = 5.0$ MHz, ADC12ON = 0, REFON = 1, REF2_5V = 1	$V_{CC} = 3$ V	0.5	0.8	mA
		$f_{ADC12CLK} = 5.0$ MHz, ADC12ON = 0, REFON = 1, REF2_5V = 0	$V_{CC} = 2.2$ V	0.5	0.8	
$C_I$	Input capacitance	Only one terminal can be selected at one time, $A_x$	$V_{CC} = 2.2$ V		40	pF
$R_I$	Input MUX ON resistance	$0$ V $\leq V_{Ax} \leq V_{AVCC}$	$V_{CC} = 3$ V		2000	$\Omega$

- (1) The leakage current is defined in the leakage current table with  $A_x$  parameter.
- (2) The analog input voltage range must be within the selected reference voltage range  $V_{R+}$  to  $V_{R-}$  for valid conversion results.
- (3) The internal reference supply current is not included in current consumption parameter  $I_{ADC12}$ .
- (4) The internal reference current is supplied via terminal AVCC. Consumption is independent of the ADC12ON control bit, unless a conversion is active. The REFON bit enables to settle the built-in reference before starting an A/D conversion.

## 8.23 12-Bit ADC, External Reference

over recommended operating free-air temperature range (unless otherwise noted)

PARAMETER <sup>(1)</sup>		TEST CONDITIONS	MIN	TYP	MAX	UNIT
$V_{eREF+}$	Positive external reference voltage input	$V_{eREF+} > V_{REF-}/N_{eREF-}$ <sup>(2)</sup>	1.4		$V_{AVCC}$	V
$V_{REF-}/N_{eREF-}$	Negative external reference voltage input	$V_{eREF+} > V_{REF-}/N_{eREF-}$ <sup>(3)</sup>	0		1.2	V
$(V_{eREF+} - V_{REF-}/N_{eREF-})$	Differential external reference voltage input	$V_{eREF+} > V_{REF-}/N_{eREF-}$ <sup>(4)</sup>	1.4		$V_{AVCC}$	V
$I_{VeREF+}$	Static input current	$0$ V $\leq V_{eREF+} \leq V_{AVCC}$	$V_{CC} = 2.2$ V, 3 V		$\pm 1$	$\mu$ A
$I_{VREF-}/N_{eREF-}$	Static input current	$0$ V $\leq V_{eREF-} \leq V_{AVCC}$	$V_{CC} = 2.2$ V, 3 V		$\pm 1$	$\mu$ A

- (1) The external reference is used during conversion to charge and discharge the capacitance array. The input capacitance,  $C_I$ , is also the dynamic load for an external reference during conversion. The dynamic impedance of the reference supply should follow the recommendations on analog-source impedance to allow the charge to settle for 12-bit accuracy.
- (2) The accuracy limits the minimum positive external reference voltage. Lower reference voltage levels may be applied with reduced accuracy requirements.
- (3) The accuracy limits the maximum negative external reference voltage. Higher reference voltage levels may be applied with reduced accuracy requirements.
- (4) The accuracy limits minimum external differential reference voltage. Lower differential reference voltage levels may be applied with reduced accuracy requirements.

## 8.24 12-Bit ADC, Built-In Reference

over recommended operating free-air temperature range (unless otherwise noted)

PARAMETER	TEST CONDITIONS	V <sub>CC</sub>	MIN	TYP	MAX	UNIT	
V <sub>REF+</sub>	Positive built in reference voltage output	REF2_5V = 1 for 2.5 V, I <sub>VREF+max</sub> ≤ I <sub>VREF+</sub> ≤ I <sub>VREF+min</sub>	3 V	2.4	2.5	2.6	V
		REF2_5V = 0 for 1.5 V, I <sub>VREF+max</sub> ≤ I <sub>VREF+</sub> ≤ I <sub>VREF+min</sub>	2.2 V, 3 V	1.44	1.5	1.56	
AV <sub>CC(min)</sub>	AV <sub>CC</sub> minimum voltage, Positive built in reference active	REF2_5V = 0, I <sub>VREF+max</sub> ≤ I <sub>VREF+</sub> ≤ I <sub>VREF+min</sub>		2.2			V
		REF2_5V = 1, I <sub>VREF+min</sub> ≥ I <sub>VREF+</sub> ≥ -0.5 mA		2.8			
		REF2_5V = 1, I <sub>VREF+min</sub> ≥ I <sub>VREF+</sub> ≥ -1 mA		2.9			
I <sub>VREF+</sub>	Load current out of V <sub>REF+</sub> terminal		2.2 V	0.01		-0.5	mA
			3 V	0.01		-1	
I <sub>L(VREF+)</sub>	Load-current regulation, V <sub>REF+</sub> terminal	I <sub>VREF+</sub> = 500 μA ± 100 μA, Analog input voltage ≈ 0.75 V, REF2_5V = 0	2.2 V			±2	LSB
			3 V			±2	
		I <sub>VREF+</sub> = 500 μA ± 100 μA, Analog input voltage ≈ 1.25 V, REF2_5V = 1	3 V			±2	LSB
I <sub>DL(VREF+)</sub>	Load current regulation, V <sub>REF+</sub> terminal	I <sub>VREF+</sub> = 100 μA → 900 μA, C <sub>VREF+</sub> = 5 μF, a <sub>x</sub> ≈ 0.5 × V <sub>REF+</sub> , Error of conversion result ≤ 1 LSB	3 V			20	ns
C <sub>VREF+</sub>	Capacitance at pin V <sub>REF+</sub> <sup>(1)</sup>	REFON = 1, 0 mA ≤ I <sub>VREF+</sub> ≤ I <sub>VREF+max</sub>	2.2 V, 3 V	5	10		μF
T <sub>REF+</sub>	Temperature coefficient of built-in reference	I <sub>VREF+</sub> is a constant in the range of 0 mA ≤ I <sub>VREF+</sub> ≤ 1 mA	2.2 V, 3 V			±100	ppm/°C
t <sub>REFON</sub>	Settle time of internal reference voltage (see Figure 8-18) <sup>(2)</sup>	I <sub>VREF+</sub> = 0.5 mA, C <sub>VREF+</sub> = 10 μF, V <sub>REF+</sub> = 1.5 V, V <sub>AVCC</sub> = 2.2 V				17	ms

- (1) The internal buffer operational amplifier and the accuracy specifications require an external capacitor. All INL and DNL tests uses two capacitors between pins V<sub>REF+</sub> and AV<sub>SS</sub> and V<sub>REF-</sub>/V<sub>eREF-</sub> and AV<sub>SS</sub>: 10 μF tantalum and 100 nF ceramic.
- (2) The condition is that the error in a conversion started after t<sub>REFON</sub> is less than ±0.5 LSB. The settling time depends on the external capacitive load.

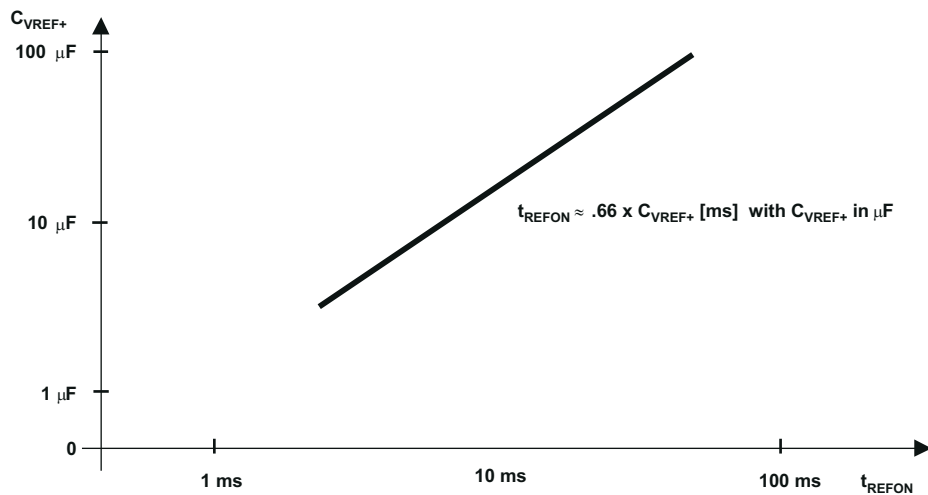

**Figure 8-18. Typical Settling Time of Internal Reference t<sub>REFON</sub> vs External Capacitor on V<sub>REF+</sub>**

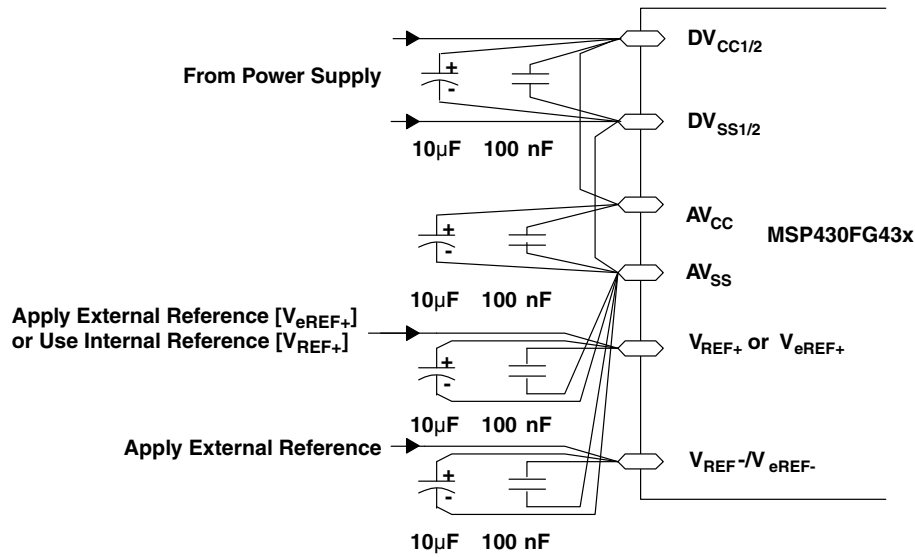

**Figure 8-19. Supply Voltage and Reference Voltage Design  $V_{REF-}/V_{eREF-}$  External Supply**

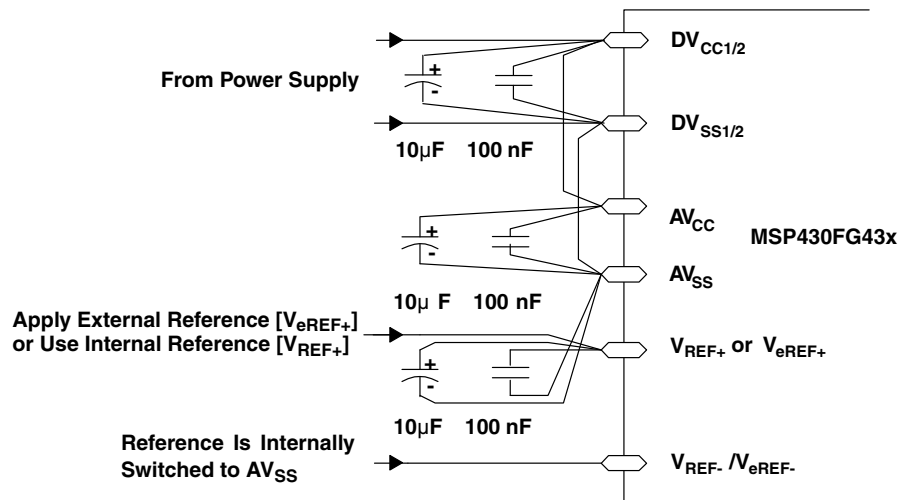

**Figure 8-20. Supply Voltage and Reference Voltage Design  $V_{REF-}/V_{eREF-} = AV_{SS}$ , Internally Connected**

## 8.25 12-Bit ADC, Timing Parameters

over recommended operating free-air temperature range (unless otherwise noted)

PARAMETER		TEST CONDITIONS	V <sub>CC</sub>	MIN	TYP	MAX	UNIT
f <sub>ADC12CLK</sub>	ADC12 clock frequency	For specified performance of ADC12 linearity parameters	2.2 V, 3 V	0.45	5	7	MHz
f <sub>ADC12OSC</sub>	Internal ADC12 oscillator	ADC12DIV = 0, f <sub>ADC12CLK</sub> = f <sub>ADC12OSC</sub>	2.2 V, 3 V	3.7	5	7	MHz
t <sub>CONVERT</sub>	Conversion time	C <sub>VREF+</sub> ≥ 5 μF, Internal oscillator, f <sub>ADC12OSC</sub> = 3.7 MHz to 7 MHz	2.2 V, 3 V	1.86		3.51	μs
		External f <sub>ADC12CLK</sub> from ACLK, MCLK, or SMCLK, ADC12SSEL ≠ 0			13 × 1/f <sub>ADC12CLK</sub>		μs
t <sub>ADC12ON</sub>	Turn on settling time of the ADC	See (1)				100	ns
t <sub>Sample</sub>	Sampling time	R <sub>S</sub> = 400 Ω, R <sub>I</sub> = 1000 Ω, C <sub>I</sub> = 30 pF, τ = [R <sub>S</sub> + R <sub>I</sub> ] × C <sub>I</sub> (2)	3 V	1220			ns
			2.2 V	1400			

(1) The condition is that the error in a conversion started after t<sub>ADC12ON</sub> is less than ±0.5 LSB. The reference and input signal are already settled.

(2) Approximately ten Tau (τ) are needed to get an error of less than ±0.5 LSB:

$$t_{\text{sample}} = \ln(2^{n+1}) \times (R_S + R_I) \times C_I + 800 \text{ ns, where } n = \text{ADC resolution} = 12, R_S = \text{external source resistance.}$$

## 8.26 12-Bit ADC, Linearity Parameters

over recommended operating free-air temperature range (unless otherwise noted)

PARAMETER		TEST CONDITIONS	V <sub>CC</sub>	MIN	TYP	MAX	UNIT
E <sub>I</sub>	Integral linearity error	1.4 V ≤ (V <sub>eREF+</sub> - V <sub>REF-/V<sub>eREF-</sub></sub> ) min ≤ 1.6 V	2.2 V, 3 V			±2	LSB
		1.6 V < (V <sub>eREF+</sub> - V <sub>REF-/V<sub>eREF-</sub></sub> ) min ≤ V <sub>AVCC</sub>				±1.7	
E <sub>D</sub>	Differential linearity error	(V <sub>eREF+</sub> - V <sub>REF-/V<sub>eREF-</sub></sub> ) min ≤ (V <sub>eREF+</sub> - V <sub>REF-/V<sub>eREF-</sub></sub> ), C <sub>VREF+</sub> = 10 μF (tantalum) and 100 nF (ceramic)	2.2 V, 3 V			±1	LSB
E <sub>O</sub>	Offset error	(V <sub>eREF+</sub> - V <sub>REF-/V<sub>eREF-</sub></sub> ) min ≤ (V <sub>eREF+</sub> - V <sub>REF-/V<sub>eREF-</sub></sub> ), Internal impedance of source R <sub>S</sub> < 100 Ω, C <sub>VREF+</sub> = 10 μF (tantalum) and 100 nF (ceramic)	2.2 V, 3 V		±2	±4	LSB
E <sub>G</sub>	Gain error	(V <sub>eREF+</sub> - V <sub>REF-/V<sub>eREF-</sub></sub> ) min ≤ (V <sub>eREF+</sub> - V <sub>REF-/V<sub>eREF-</sub></sub> ), C <sub>VREF+</sub> = 10 μF (tantalum) and 100 nF (ceramic)	2.2 V, 3 V		±1.1	±2	LSB
E <sub>T</sub>	Total unadjusted error	(V <sub>eREF+</sub> - V <sub>REF-/V<sub>eREF-</sub></sub> ) min ≤ (V <sub>eREF+</sub> - V <sub>REF-/V<sub>eREF-</sub></sub> ), C <sub>VREF+</sub> = 10 μF (tantalum) and 100 nF (ceramic)	2.2 V, 3 V		±2	±5	LSB

## 8.27 12-Bit ADC, Temperature Sensor and Built-In $V_{MID}$

over recommended operating free-air temperature range (unless otherwise noted)

PARAMETER		TEST CONDITIONS	$V_{CC}$	MIN	TYP	MAX	UNIT
$I_{SENSOR}$	Operating supply current into $AV_{CC}$ terminal <sup>(1)</sup>	REFON = 0, INCH = 0Ah, ADC12ON = NA, $T_A = 25^\circ C$	2.2 V		40	120	$\mu A$
			3 V		60	160	
$V_{SENSOR}$	See (2)	ADC12ON = 1, INCH = 0Ah, $T_A = 0^\circ C$	2.2 V, 3 V		986		mV
$TC_{SENSOR}$		ADC12ON = 1, INCH = 0Ah	2.2 V, 3 V		3.55 ± 3%		mV/ $^\circ C$
$t_{SENSOR(sample)}$	Sample time required if channel 10 is selected <sup>(3)</sup>	ADC12ON = 1, INCH = 0Ah, Error of conversion result $\leq 1$ LSB	2.2 V	30			$\mu s$
			3 V	30			
$I_{VMID}$	Current into divider at channel 11 <sup>(4)</sup>	ADC12ON = 1, INCH = 0Bh	2.2 V			NA	$\mu A$
			3 V			NA	
$V_{MID}$	$AV_{CC}$ divider at channel 11	ADC12ON = 1, INCH = 0Bh, $V_{MID} \approx 0.5 \times V_{AVCC}$	2.2 V		1.1	1.10 ± 0.04	V
			3 V		1.5	1.50 ± 0.04	
$t_{VMID(sample)}$	Sample time required if channel 11 is selected <sup>(5)</sup>	ADC12ON = 1, INCH = 0Bh, Error of conversion result $\leq 1$ LSB	2.2 V	1400			ns
			3 V	1220			

- (1) The sensor current  $I_{SENSOR}$  is consumed if (ADC12ON = 1 and REFON = 1), or (ADC12ON = 1 AND INCH = 0Ah and sample signal is high). When REFON = 1,  $I_{SENSOR}$  is already included in  $I_{REF+}$ .
- (2) The temperature sensor offset can be as much as  $\pm 20^\circ C$ . A single-point calibration is recommended in order to minimize the offset error of the built-in temperature sensor.
- (3) The typical equivalent impedance of the sensor is 51 k $\Omega$ . The sample time required includes the sensor-on time  $t_{SENSOR(on)}$ .
- (4) No additional current is needed. The  $V_{MID}$  is used during sampling.
- (5) The on-time  $t_{VMID(on)}$  is included in the sampling time  $t_{VMID(sample)}$ ; no additional on time is needed.

## 8.28 12-Bit DAC, Supply Specifications

over recommended operating free-air temperature range (unless otherwise noted)

PARAMETER		TEST CONDITIONS	$V_{CC}$	MIN	TYP	MAX	UNIT
$AV_{CC}$	Analog supply voltage	$AV_{CC} = DV_{CC}$ , $AV_{SS} = DV_{SS} = 0 V$		2.2		3.6	V
$I_{DD}$	Supply current, single DAC channel <sup>(1) (2)</sup>	DAC12AMPx = 2, DAC12IR = 0, DAC12_xDAT = 0800h	2.2 V, 3 V		50	110	$\mu A$
		DAC12AMPx = 2, DAC12IR = 1, DAC12_xDAT = 0800h, $V_{eREF+} = V_{REF+} = AV_{CC}$			50	110	
		DAC12AMPx = 5, DAC12IR = 1, DAC12_xDAT = 0800h, $V_{eREF+} = V_{REF+} = AV_{CC}$			200	440	
		DAC12AMPx = 7, DAC12IR = 1, DAC12_xDAT = 0800h, $V_{eREF+} = V_{REF+} = AV_{CC}$			700	1500	
PSRR	Power-supply rejection ratio <sup>(3) (4)</sup>	DAC12_xDAT = 0800h, $V_{REF} = 1.5 V$ , $\Delta AV_{CC} = 100 mV$	2.2 V		70		dB
		DAC12_xDAT = 0800h, $V_{REF} = 1.5 V$ or 2.5 V, $\Delta AV_{CC} = 100 mV$	3 V				

- (1) No load at the output pin, DAC0 or DAC1, assuming that the control bits for the shared pins are set properly.
- (2) Current into reference terminals not included. If DAC12IR = 1, current flows through the input divider (see Reference Input specifications).
- (3)  $PSRR = 20 \times \log(\Delta AV_{CC} / \Delta V_{DAC12\_xOUT})$ .
- (4)  $V_{REF}$  is applied externally. The internal reference is not used.

## 8.29 12-Bit DAC, Linearity Specifications

over recommended operating free-air temperature range (unless otherwise noted) (see [Figure 8-21](#))

PARAMETER		TEST CONDITIONS	V <sub>CC</sub>	MIN	TYP	MAX	UNIT
Resolution		12-bit monotonic		12			bits
INL	Integral nonlinearity <sup>(1)</sup>	V <sub>ref</sub> = 1.5 V, DAC12AMP <sub>x</sub> = 7, DAC12IR = 1	2.2 V	±2.0		±8.0	LSB
		V <sub>ref</sub> = 2.5 V, DAC12AMP <sub>x</sub> = 7, DAC12IR = 1	3 V				
DNL	Differential nonlinearity <sup>(1)</sup>	V <sub>ref</sub> = 1.5 V, DAC12AMP <sub>x</sub> = 7, DAC12IR = 1	2.2 V	±0.4		±1.0	LSB
		V <sub>ref</sub> = 2.5 V, DAC12AMP <sub>x</sub> = 7, DAC12IR = 1	3 V				
E <sub>O</sub>	Offset voltage without calibration <sup>(1) (2)</sup>	V <sub>ref</sub> = 1.5 V, DAC12AMP <sub>x</sub> = 7, DAC12IR = 1	2.2 V			±21	mV
		V <sub>ref</sub> = 2.5 V, DAC12AMP <sub>x</sub> = 7, DAC12IR = 1	3 V				
	Offset voltage with calibration <sup>(1) (2)</sup>	V <sub>ref</sub> = 1.5 V, DAC12AMP <sub>x</sub> = 7, DAC12IR = 1	2.2 V				
		V <sub>ref</sub> = 2.5 V, DAC12AMP <sub>x</sub> = 7, DAC12IR = 1	3 V				
d <sub>E(O)</sub> /d <sub>T</sub>	Offset error temperature coefficient <sup>(1)</sup>		2.2 V, 3 V		±30		μV/°C
E <sub>G</sub>	Gain error <sup>(1)</sup>	V <sub>REF</sub> = 1.5 V	2.2 V			±3.5	%FSR
		V <sub>REF</sub> = 2.5 V	3 V				
d <sub>E(G)</sub> /d <sub>T</sub>	Gain temperature coefficient <sup>(1)</sup>		2.2 V, 3 V		10		ppm of FSR/°C
t <sub>Offset Cal</sub>	Time for offset calibration <sup>(3)</sup>	DAC12AMP <sub>x</sub> = 2	2.2 V, 3 V			100	ms
		DAC12AMP <sub>x</sub> = 3, 5				32	
		DAC12AMP <sub>x</sub> = 4, 6, 7				6	

- (1) Parameters calculated from the best-fit curve from 0x0A to 0xFFF. The best-fit curve method is used to deliver coefficients "a" and "b" of the first-order equation:  $y = a + b \times x$ .  $V_{DAC12\_xOUT} = E_O + (1 + E_G) \times (V_{eREF+} / 4095) \times DAC12\_xDAT$ , DAC12IR = 1.
- (2) The offset calibration works on the output operational amplifier. Offset Calibration is triggered setting bit DAC12CALON.
- (3) The offset calibration can be done if DAC12AMP<sub>x</sub> = {2, 3, 4, 5, 6, 7}. The output operational amplifier is switched off with DAC12AMP<sub>x</sub> = {0, 1}. It is recommended that the DAC12 module be configured prior to initiating calibration. Port activity during calibration may affect accuracy and is not recommended.

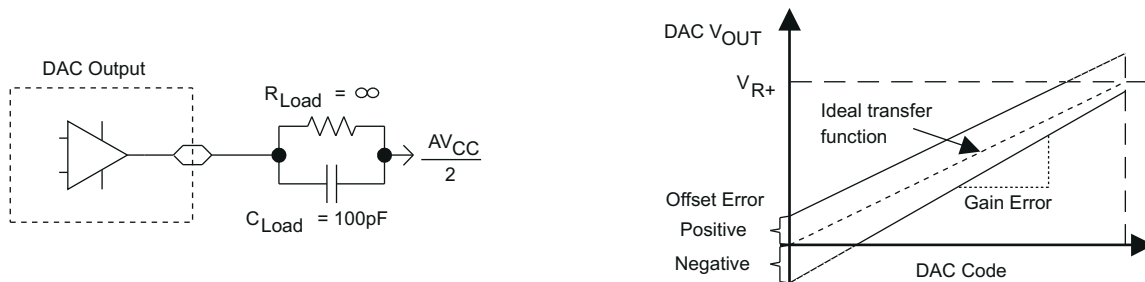

**Figure 8-21. Linearity Test Load Conditions and Gain/Offset Definition**

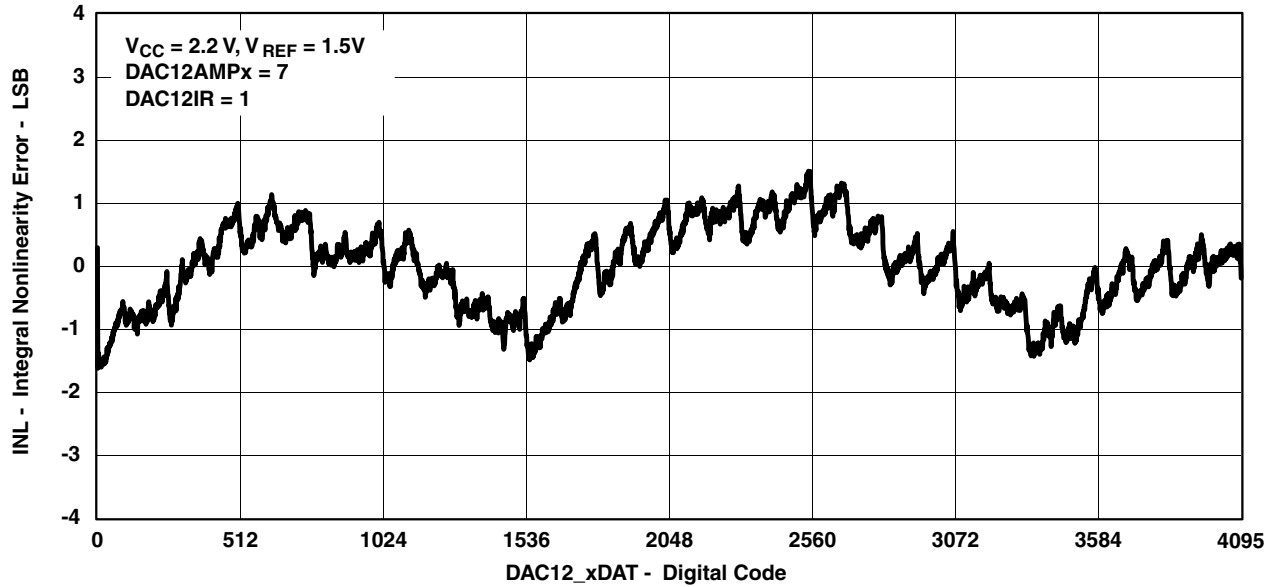

Figure 8-22. Typical INL Error vs Digital Input Data

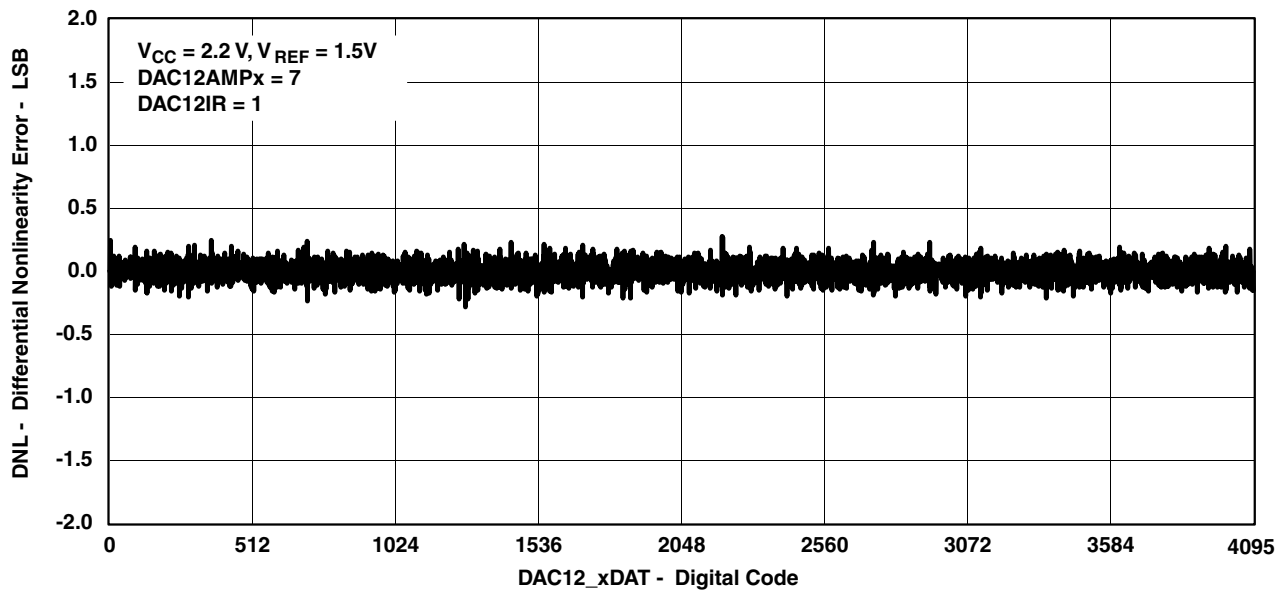

Figure 8-23. Typical DNL Error vs Digital Input Data

### 8.30 12-Bit DAC, Output Specifications

over recommended operating free-air temperature (unless otherwise noted)

PARAMETER	TEST CONDITIONS	V <sub>CC</sub>	MIN	TYP	MAX	UNIT	
V <sub>O</sub> Output voltage range <sup>(1)</sup> (see Figure 8-24)	No Load, V <sub>eREF+</sub> = AV <sub>CC</sub> , DAC12_xDAT = 0h, DAC12IR = 1, DAC12AMPx = 7	2.2 V, 3 V	0		0.005	V	
	No Load, V <sub>eREF+</sub> = AV <sub>CC</sub> , DAC12_xDAT = 0FFFh, DAC12IR = 1, DAC12AMPx = 7		AV <sub>CC</sub> - 0.05		AV <sub>CC</sub>		
	R <sub>Load</sub> = 3 kΩ, V <sub>eREF+</sub> = AV <sub>CC</sub> , DAC12_xDAT = 0h, DAC12IR = 1, DAC12AMPx = 7		0		0.1		
	R <sub>Load</sub> = 3 kΩ, V <sub>eREF+</sub> = AV <sub>CC</sub> , DAC12_xDAT = 0FFFh, DAC12IR = 1, DAC12AMPx = 7		AV <sub>CC</sub> - 0.13		AV <sub>CC</sub>		
C <sub>L(DAC12)</sub>	Maximum DAC12 load capacitance	2.2 V, 3 V			100	pF	
I <sub>L(DAC12)</sub>	Maximum DAC12 load current	2.2 V	-0.5		+0.5	mA	
		3 V	-1.0		+1.0		
R <sub>O/P(DAC12)</sub>	Output resistance (see Figure 8-24)	2.2 V, 3 V	R <sub>Load</sub> = 3 kΩ, V <sub>O/P(DAC12)</sub> < 0.3 V, DAC12AMPx = 7, DAC12_xDAT = 0h		150	250	Ω
			R <sub>Load</sub> = 3 kΩ, V <sub>O/P(DAC12)</sub> > AV <sub>CC</sub> - 0.3 V, DAC12AMPx = 7, DAC12_xDAT = 0FFFh		150	250	
			R <sub>Load</sub> = 3 kΩ, 0.3 V ≤ V <sub>O/P(DAC12)</sub> ≤ AV <sub>CC</sub> - 0.3 V DAC12AMPx = 7		1	4	

(1) Data is valid after the offset calibration of the output amplifier.

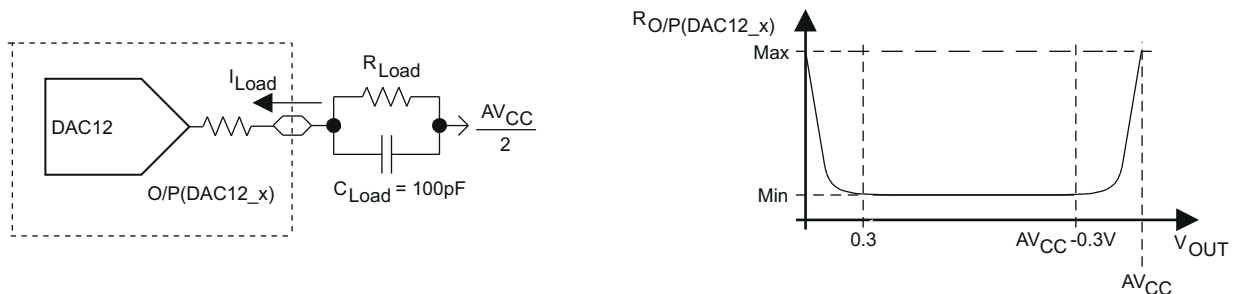

Figure 8-24. DAC12\_x Output Resistance Tests

### 8.31 12-Bit DAC, Reference Input Specifications

over recommended operating free-air temperature range (unless otherwise noted)

PARAMETER	TEST CONDITIONS	V <sub>CC</sub>	MIN	TYP	MAX	UNIT
V <sub>REF+</sub> Reference input voltage range	DAC12IR = 0 <sup>(1)</sup> <sup>(2)</sup>	2.2 V, 3 V	AV <sub>CC</sub> / 3		AV <sub>CC</sub> + 0.2	V
	DAC12IR = 1 <sup>(3)</sup> <sup>(4)</sup>		AV <sub>CC</sub>		AV <sub>CC</sub> + 0.2	
R <sub>i(VREF+)</sub> , R <sub>i(VREF+)</sub> Reference input resistance	DAC12_0 IR = DAC12_1 IR = 0	2.2 V, 3 V	20			MΩ
	DAC12_0 IR = 1, DAC12_1 IR = 0		40	48	150	kΩ
	DAC12_0 IR = 0, DAC12_1 IR = 1		40	48	150	
	DAC12_0 IR = DAC12_1 IR = 1, DAC12_0 SREFx = DAC12_1 SREFx <sup>(5)</sup>		20	24	75	

- (1) For a full-scale output, the reference input voltage can be as high as 1/3 of the maximum output voltage swing (AV<sub>CC</sub>).
- (2) The maximum voltage applied at reference input voltage terminal V<sub>REF+</sub> = [AV<sub>CC</sub> - V<sub>E(O)</sub>] / [3 × (1 + E<sub>G</sub>)].
- (3) For a full-scale output, the reference input voltage can be as high as the maximum output voltage swing (AV<sub>CC</sub>).
- (4) The maximum voltage applied at reference input voltage terminal V<sub>REF+</sub> = [AV<sub>CC</sub> - V<sub>E(O)</sub>] / (1 + E<sub>G</sub>).
- (5) When DAC12IR = 1 and DAC12SREFx = 0 or 1 for both channels, the reference input resistive dividers for each DAC are in parallel, reducing the reference input resistance.

### 8.32 12-Bit DAC, Dynamic Specifications

V<sub>ref</sub> = V<sub>CC</sub>, DAC12IR = 1, over recommended operating free-air temperature range (unless otherwise noted) (see Figure 8-25 and Figure 8-26)

PARAMETER	TEST CONDITIONS	V <sub>CC</sub>	MIN	TYP	MAX	UNIT
t <sub>ON</sub> DAC12 on time	DAC12_xDAT = 800h, Error <sub>V(O)</sub> < ±0.5 LSB <sup>(1)</sup> (see Figure 8-25)	2.2 V, 3 V		60	120	μs
	DAC12AMPx = 0 → {2, 3, 4}			15	30	
	DAC12AMPx = 0 → 7			6	12	
t <sub>S(FS)</sub> Settling time, full scale	DAC12_xDAT = 80h → F7Fh → 80h	2.2 V, 3 V		100	200	μs
	DAC12AMPx = 2			40	80	
	DAC12AMPx = 3, 5			15	30	
t <sub>S(C-C)</sub> Settling time, code to code	DAC12_xDAT = 3F8h → 408h → 3F8h	2.2 V, 3 V		5		μs
	BF8h → C08h → BF8h			2		
	DAC12AMPx = 4, 6, 7			1		
SR Slew rate	DAC12_xDAT = 80h → F7Fh → 80h <sup>(2)</sup>	2.2 V, 3 V		0.05	0.12	V/μs
	DAC12AMPx = 2			0.35	0.7	
	DAC12AMPx = 3, 5			1.5	2.7	
Glitch energy, full scale	DAC12_xDAT = 80h → F7Fh → 80h	2.2 V, 3 V		10		nV-s
	DAC12AMPx = 2			10		
	DAC12AMPx = 3, 5			10		
	DAC12AMPx = 4, 6, 7			10		

- (1) R<sub>Load</sub> and C<sub>Load</sub> connected to AV<sub>SS</sub> (not AV<sub>CC</sub>/2) in Figure 8-25.
- (2) Slew rate applies to output voltage steps ≥ 200 mV.

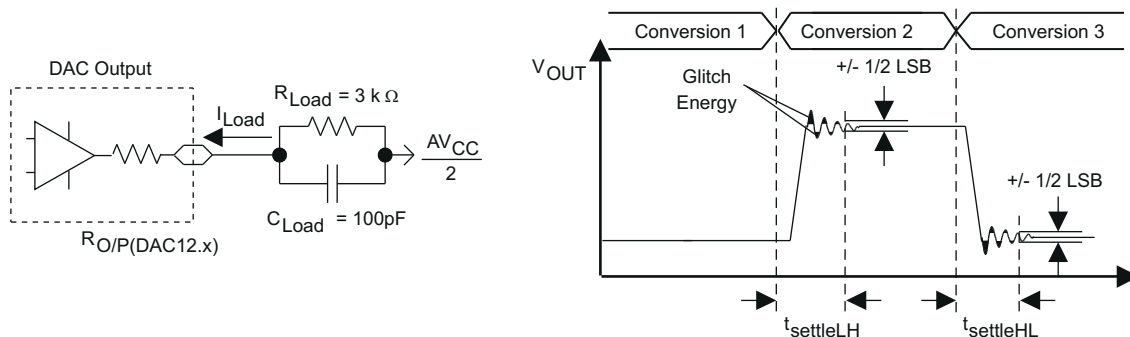

**Figure 8-25. Settling Time and Glitch Energy Testing**

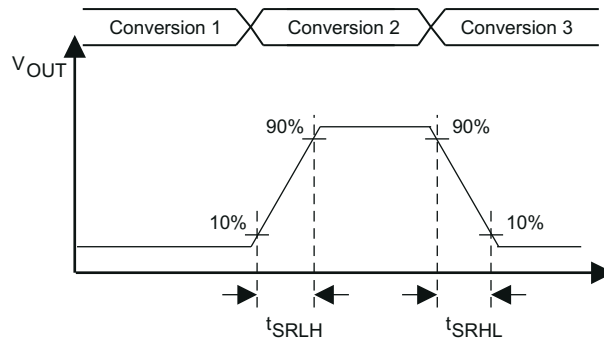

Figure 8-26. Slew Rate Testing

### 8.33 12-Bit DAC, Dynamic Specifications (Continued)

T<sub>A</sub> = 25°C unless otherwise noted

PARAMETER	TEST CONDITIONS	V <sub>CC</sub>	MIN	TYP	MAX	UNIT
BW <sub>-3dB</sub> 3-dB bandwidth, V <sub>DC</sub> = 1.5 V, V <sub>AC</sub> = 0.1 V <sub>PP</sub> (see Figure 8-27)	DAC12AMP <sub>x</sub> = {2, 3, 4}, DAC12SREF <sub>x</sub> = 2, DAC12IR = 1, DAC12_xDAT = 800h	2.2 V, 3 V	40			kHz
	DAC12AMP <sub>x</sub> = {5, 6}, DAC12SREF <sub>x</sub> = 2, DAC12IR = 1, DAC12_xDAT = 800h		180			
	DAC12AMP <sub>x</sub> = 7, DAC12SREF <sub>x</sub> = 2, DAC12IR = 1, DAC12_xDAT = 800h		550			
Channel-to-channel crosstalk <sup>(1)</sup> (see Figure 8-28)	DAC12_0DAT = 800h, No Load, DAC12_1DAT = 80h ↔ F7Fh, R <sub>Load</sub> = 3 kΩ f <sub>DAC12_1OUT</sub> = 10 kHz with 50/50 duty cycle	2.2 V, 3 V		-80		dB
	DAC12_0DAT = 80h ↔ F7Fh, R <sub>Load</sub> = 3 kΩ, DAC12_1DAT = 800h, No Load, f <sub>DAC12_0OUT</sub> = 10 kHz with 50/50 duty cycle			-80		

(1) R<sub>LOAD</sub> = 3 kΩ, C<sub>LOAD</sub> = 100 pF

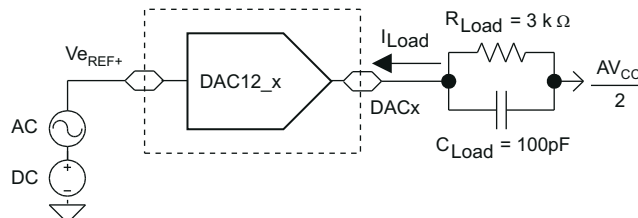

Figure 8-27. Test Conditions for 3-dB Bandwidth Specification

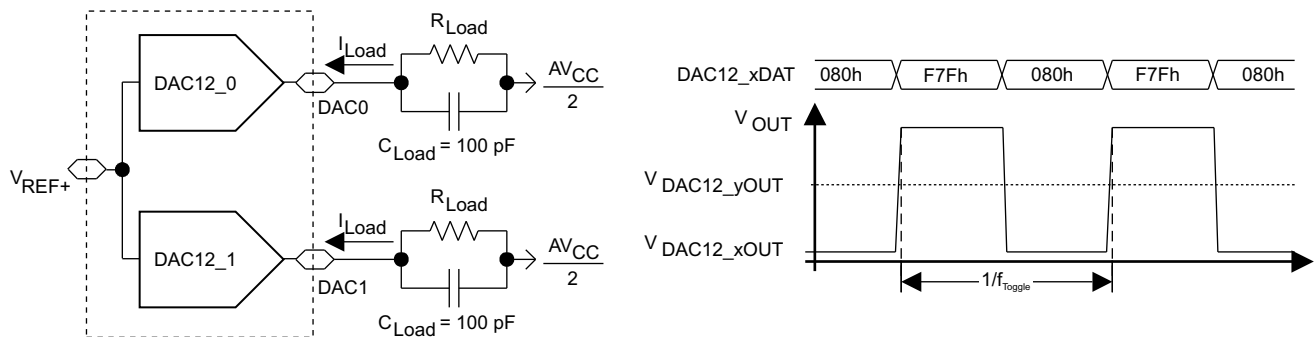

Figure 8-28. Crosstalk Test Conditions

### 8.34 Operational Amplifier (OA), Supply Specifications

over recommended operating free-air temperature range (unless otherwise noted)

PARAMETER		TEST CONDITIONS	V <sub>CC</sub>	MIN	TYP	MAX	UNIT
V <sub>CC</sub>	Supply voltage			2.2		3.6	V
I <sub>CC</sub>	Supply current <sup>(1)</sup>	Fast Mode, RRIP OFF	2.2 V, 3 V		180	290	μA
		Medium Mode, RRIP OFF			110	190	
		Slow Mode, RRIP OFF			50	80	
		Fast Mode, RRIP ON			300	490	
		Medium Mode, RRIP ON			190	350	
		Slow Mode, RRIP ON			90	190	
PSRR	Power supply rejection ratio	Non-inverting	2.2 V, 3 V		70		dB

(1) P6SEL.x = 1 for each corresponding pin when used in OA input or OA output mode.

### 8.35 Operational Amplifier (OA), Input/Output Specifications

over recommended operating free-air temperature range (unless otherwise noted)

PARAMETER		TEST CONDITIONS	V <sub>CC</sub>	MIN	TYP	MAX	UNIT	
V <sub>I/P</sub>	Voltage supply, I/P	RRIP OFF		-0.1		V <sub>CC</sub> - 1.2	V	
		RRIP ON		-0.1		V <sub>CC</sub> + 0.1		
I <sub>Ikg</sub>	Input leakage current, I/P <sup>(1) (2)</sup>	T <sub>A</sub> = -40°C to +55°C		-5	±0.5	5	nA	
		T <sub>A</sub> = +55°C to +85°C		-20	±5	20		
V <sub>n</sub>	Voltage noise density, I/P	Fast Mode			50		nV/√Hz	
		Medium Mode		f <sub>V(I/P)</sub> = 1 kHz		80		
		Slow Mode				140		
		Fast Mode		f <sub>V(I/P)</sub> = 10 kHz		30		
		Medium Mode				50		
		Slow Mode				65		
V <sub>IO</sub>	Offset voltage, I/P		2.2 V, 3 V			±10	mV	
	Offset temperature drift, I/P	See <sup>(3)</sup>	2.2 V, 3 V		±10		μV/°C	
	Offset voltage drift with supply, I/P	0.3 V ≤ V <sub>IN</sub> ≤ V <sub>CC</sub> - 0.3 V ΔV <sub>CC</sub> ≤ ±10%, T <sub>A</sub> = 25°C	2.2 V, 3 V			±1.5	mV/V	
V <sub>OH</sub>	High-level output voltage, O/P	Fast Mode, I <sub>SOURCE</sub> ≤ -500 μA	2.2 V	V <sub>CC</sub> - 0.2		V <sub>CC</sub>	V	
		Slow Mode, I <sub>SOURCE</sub> ≤ -150 μA	3 V	V <sub>CC</sub> - 0.1		V <sub>CC</sub>		
V <sub>OL</sub>	Low-level output voltage, O/P	Fast Mode, I <sub>SOURCE</sub> ≤ +500 μA	2.2 V	V <sub>SS</sub>		0.2	V	
		Slow Mode, I <sub>SOURCE</sub> ≤ +150 μA	3 V	V <sub>SS</sub>		0.1		
R <sub>O/P (OAx)</sub>	Output resistance <sup>(4)</sup> (see Figure 8-29)	R <sub>Load</sub> = 3 kΩ, C <sub>Load</sub> = 50 pF, RRIP ON, V <sub>O/P(OAx)</sub> < 0.2 V	2.2 V, 3 V		150	250	Ω	
		R <sub>Load</sub> = 3 kΩ, C <sub>Load</sub> = 50 pF, RRIP ON, V <sub>O/P(OAx)</sub> > AV <sub>CC</sub> - 0.2 V			150	250		
		R <sub>Load</sub> = 3 kΩ, C <sub>Load</sub> = 50 pF, RRIP ON, 0.2 V ≤ V <sub>O/P(OAx)</sub> ≤ AV <sub>CC</sub> - 0.2 V			0.1	4		
CMRR	Common-mode rejection ratio	Non-inverting	2.2 V, 3 V		70		dB	

- (1) ESD damage can degrade input current leakage.
- (2) The input bias current is overridden by the input leakage current.
- (3) Calculated using the box method.
- (4) Specification valid for voltage-follower OAx configuration.

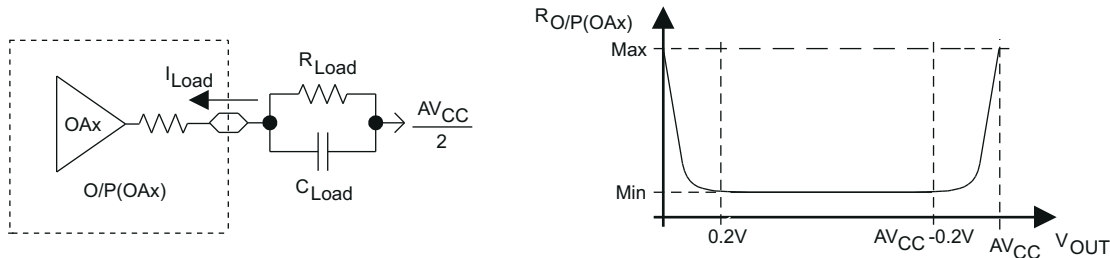

Figure 8-29. OAx Output Resistance Tests

### 8.36 Operational Amplifier (OA), Dynamic Specifications

over recommended operating free-air temperature range (unless otherwise noted)

PARAMETER		TEST CONDITIONS	V <sub>CC</sub>	MIN	TYP	MAX	UNIT
SR	Slew rate	Fast Mode			1.2		V/μs
		Medium Mode		0.8			
		Slow Mode		0.3			
	Open-loop voltage gain			100		dB	
φ <sub>m</sub>	Phase margin	C <sub>L</sub> = 50 pF			60		deg
	Gain margin	C <sub>L</sub> = 50 pF			20		dB
GBW	Gain-bandwidth product (see Figure 8-30 and Figure 8-31)	Non-inverting, Fast Mode, R <sub>L</sub> = 47 kΩ, C <sub>L</sub> = 50 pF	2.2 V, 3 V		2.2		MHz
		Non-inverting, Medium Mode, R <sub>L</sub> = 300 kΩ, C <sub>L</sub> = 50 pF		1.4			
		Non-inverting, Slow Mode, R <sub>L</sub> = 300 kΩ, C <sub>L</sub> = 50 pF		0.5			
t <sub>en(on)</sub>	Enable time on	t <sub>on</sub> , non-inverting, Gain = 1	2.2 V, 3 V		10	20	μs
t <sub>en(off)</sub>	Enable time off		2.2 V, 3 V			1	μs

### 8.37 OA Dynamic Specifications Typical Characteristics

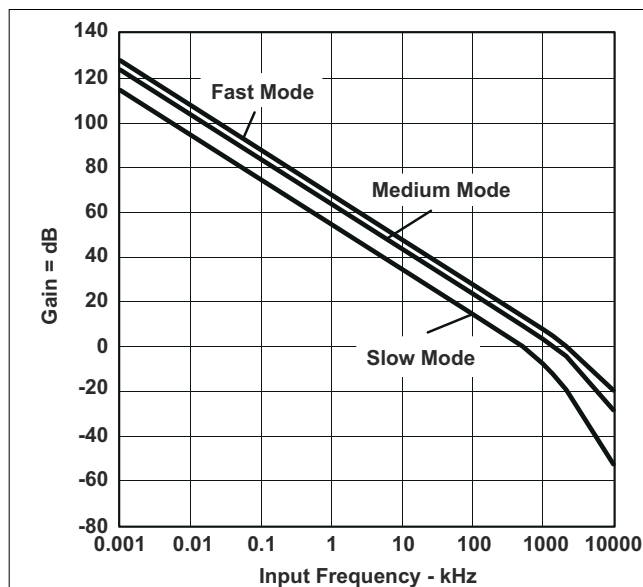

Figure 8-30. Typical Open-Loop Gain vs Frequency

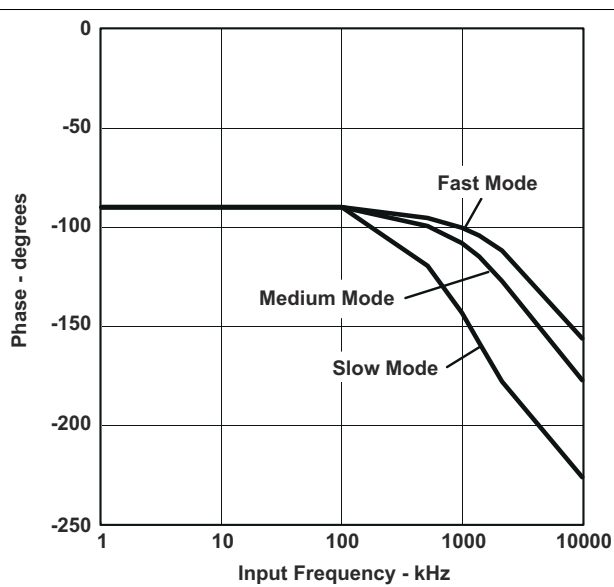

Figure 8-31. Typical Phase vs Frequency

## 8.38 Flash Memory

over recommended operating free-air temperature range (unless otherwise noted)

PARAMETER		TEST CONDITIONS	V <sub>CC</sub>	MIN	TYP	MAX	UNIT
V <sub>CC(PGM/ERASE)</sub>	Program and erase supply voltage			2.7		3.6	V
f <sub>FTG</sub>	Flash timing generator frequency			257		476	kHz
I <sub>PGM</sub>	Supply current from DV <sub>CC</sub> during program		2.7 V, 3.6 V		3	5	mA
I <sub>ERASE</sub>	Supply current from DV <sub>CC</sub> during erase		2.7 V, 3.6 V		3	7	mA
t <sub>CPT</sub>	Cumulative program time	See (1)	2.7 V, 3.6 V			10	ms
t <sub>CMErase</sub>	Cumulative mass erase time	See (2)	2.7 V, 3.6 V	200			ms
	Program and erase endurance			10 <sup>4</sup>	10 <sup>5</sup>		cycles
t <sub>Retention</sub>	Data retention duration	T <sub>J</sub> = 25°C		100			years
t <sub>Word</sub>	Word or byte program time	See (3)			35		t <sub>FTG</sub>
t <sub>Block, 0</sub>	Block program time for first byte or word				30		
t <sub>Block, 1-63</sub>	Block program time for each additional byte or word				21		
t <sub>Block, End</sub>	Block program end-sequence wait time				6		
t <sub>Mass Erase</sub>	Mass erase time				5297		
t <sub>Seg Erase</sub>	Segment erase time				4819		

- (1) The cumulative program time must not be exceeded when writing to a 64-byte flash block. This parameter applies to all programming methods: individual word or byte write and block write modes.
- (2) The mass erase duration generated by the flash timing generator is at least 11.1 ms ( = 5297 × 1/f<sub>FTG,max</sub> = 5297 × 1 / 476 kHz). To achieve the required cumulative mass erase time the Flash Controller's mass erase operation can be repeated until this time is met. (A worst case minimum of 19 cycles are required).
- (3) These values are hard-wired into the flash controller's state machine (t<sub>FTG</sub> = 1 / f<sub>FTG</sub>).

## 8.39 JTAG Interface

over recommended operating free-air temperature range (unless otherwise noted)

PARAMETER		TEST CONDITIONS	V <sub>CC</sub>	MIN	TYP	MAX	UNIT
f <sub>TCK</sub>	TCK input frequency	See (1)	2.2 V	0		5	MHz
			3 V	0		10	MHz
R <sub>Internal</sub>	Internal pullup resistance on TMS, TCK, TDI/TCLK	See (2)	2.2 V, 3 V	25	60	90	kΩ

- (1) f<sub>TCK</sub> may be restricted to meet the timing requirements of the module selected.
- (2) TMS, TDI/TCLK, and TCK pullup resistors are implemented in all versions.

## 8.40 JTAG Fuse

over recommended operating free-air temperature range (unless otherwise noted)

PARAMETER <sup>(1)</sup>		TEST CONDITIONS	MIN	MAX	UNIT
V <sub>CC(FB)</sub>	Supply voltage during fuse-blow condition	T <sub>A</sub> = 25°C	2.5		V
V <sub>FB</sub>	Voltage level on TDI/TCLK for fuse-blow		6	7	V
I <sub>FB</sub>	Supply current into TDI/TCLK during fuse blow			100	mA
t <sub>FB</sub>	Time to blow fuse			1	ms

- (1) After the fuse is blown, no further access to the MSP430 JTAG/Test and emulation features is possible. The JTAG block is switched to bypass mode.

## 9 Detailed Description

### 9.1 CPU

The MSP430 CPU has a 16-bit RISC architecture that is highly transparent to the application. All operations, other than program-flow instructions, are performed as register operations in conjunction with seven addressing modes for source operand and four addressing modes for destination operand.

The CPU is integrated with 16 registers that provide reduced instruction execution time. The register-to-register operation execution time is one cycle of the CPU clock.

Four of the registers, R0 to R3, are dedicated as program counter, stack pointer, status register, and constant generator respectively. The remaining registers are general-purpose registers.

Peripherals are connected to the CPU using data, address, and control buses, and can be handled with all instructions.

Program Counter	PC/R0
Stack Pointer	SP/R1
Status Register	SR/CG1/R2
Constant Generator	CG2/R3
General-Purpose Register	R4
General-Purpose Register	R5
General-Purpose Register	R6
General-Purpose Register	R7
General-Purpose Register	R8
General-Purpose Register	R9
General-Purpose Register	R10
General-Purpose Register	R11
General-Purpose Register	R12
General-Purpose Register	R13
General-Purpose Register	R14
General-Purpose Register	R15

## 9.2 Instruction Set

The instruction set consists of the original 51 instructions with three formats and seven address modes and additional instructions for the expanded address range. Each instruction can operate on word and byte data. [Table 9-1](#) shows examples of the three types of instruction formats; [Table 9-2](#) lists the address modes.

**Table 9-1. Instruction Word Formats**

INSTRUCTION FORMAT	EXAMPLE	OPERATION
Dual operands, source-destination	ADD R4,R5	$R4 + R5 \rightarrow R5$
Single operands, destination only	CALL R8	$PC \rightarrow (TOS), R8 \rightarrow PC$
Relative jump, un/conditional	JNE	Jump-on-equal bit = 0

**Table 9-2. Address Mode Descriptions**

ADDRESS MODE	S <sup>(1)</sup>	D <sup>(1)</sup>	SYNTAX	EXAMPLE	OPERATION
Register	✓	✓	MOV Rs,Rd	MOV R10,R11	$R10 \rightarrow R11$
Indexed	✓	✓	MOV X(Rn),Y(Rm)	MOV 2(R5),6(R6)	$M(2+R5) \rightarrow M(6+R6)$
Symbolic (PC relative)	✓	✓	MOV EDE,TONI		$M(EDE) \rightarrow M(TONI)$
Absolute	✓	✓	MOV & MEM, & TCDAT		$M(MEM) \rightarrow M(TCDAT)$
Indirect	✓		MOV @Rn,Y(Rm)	MOV @R10,Tab(R6)	$M(R10) \rightarrow M(Tab+R6)$
Indirect autoincrement	✓		MOV @Rn+,Rm	MOV @R10+,R11	$M(R10) \rightarrow R11$ $R10 + 2 \rightarrow R10$
Immediate	✓		MOV #X,TONI	MOV #45,TONI	$\#45 \rightarrow M(TONI)$

(1) S = source D = destination

### 9.3 Operating Modes

The MSP430 has one active mode and five software-selectable low-power modes of operation. An interrupt event can wake up the device from any of the five low-power modes, service the request, and restore back to the low-power mode on return from the interrupt program.

The following six operating modes can be configured by software:

- Active mode (AM)
  - All clocks are active
- Low-power mode 0 (LPM0)
  - CPU is disabled
  - ACLK and SMCLK remain active. MCLK is disabled
  - FLL+ loop control remains active
- Low-power mode 1 (LPM1)
  - CPU is disabled
  - FLL+ loop control is disabled
  - ACLK and SMCLK remain active. MCLK is disabled
- Low-power mode 2 (LPM2)
  - CPU is disabled
  - MCLK, FLL+ loop control and DCOCLK are disabled
  - DCO's dc-generator remains enabled
  - ACLK remains active
- Low-power mode 3 (LPM3)
  - CPU is disabled
  - MCLK, FLL+ loop control, and DCOCLK are disabled
  - DCO's dc-generator is disabled
  - ACLK remains active
- Low-power mode 4 (LPM4)
  - CPU is disabled
  - ACLK is disabled
  - MCLK, FLL+ loop control, and DCOCLK are disabled
  - DCO's dc-generator is disabled
  - Crystal oscillator is stopped

## 9.4 Interrupt Vector Addresses

The interrupt vectors and the power-up start address are located in the address range 0FFFFh to 0FFC0h. The vector contains the 16-bit address of the appropriate interrupt-handler instruction sequence.

**Table 9-3. Interrupt Sources, Flags, and Vectors of MSP430FG43x Configurations**

INTERRUPT SOURCE	INTERRUPT FLAG	SYSTEM INTERRUPT	WORD ADDRESS	PRIORITY
Power-Up External Reset Watchdog Flash Memory	WDTIFG KEYV <sup>(1)</sup>	Reset	0FFFEh	15, highest
NMI Oscillator Fault Flash Memory Access Violation	NMIIFG <sup>(1)</sup> OFIFG <sup>(1)</sup> ACCVIFG <sup>(1)</sup>	(Non)maskable <sup>(2)</sup> (Non)maskable (Non)maskable	0FFFCCh	14
Timer_B3	TBCCR0 CCIFG0 <sup>(3)</sup>	Maskable	0FFFAh	13
Timer_B3	TBCCR1 CCIFG1 and TBCCR2 CCIFG2, TBIFG <sup>(1) (3)</sup>	Maskable	0FFF8h	12
Comparator_A	CAIFG	Maskable	0FFF6h	11
Watchdog Timer	WDTIFG	Maskable	0FFF4h	10
USART0 Receive	URXIFG0	Maskable	0FFF2h	9
USART0 Transmit	UTXIFG0	Maskable	0FFF0h	8
ADC12	ADC12IFG <sup>(1) (3)</sup>	Maskable	0FFEEh	7
Timer_A3	TACCR0 CCIFG0 <sup>(3)</sup>	Maskable	0FFECCh	6
Timer_A3	TACCR1 CCIFG1 and TACCR2 CCIFG2, TAIFG <sup>(1)</sup> <sup>(3)</sup>	Maskable	0FFEAh	5
I/O Port P1 (Eight Flags)	P1IFG.0 to P1IFG.7 <sup>(1) (3)</sup>	Maskable	0FFE8h	4
DAC12 DMA	DAC12.0IFG, DAC12.1IFG, DMA0IFG <sup>(1) (3)</sup>	Maskable	0FFE6h	3
			0FFE4h	2
I/O Port P2 (Eight Flags)	P2IFG.0 to P2IFG.7 <sup>(1) (3)</sup>	Maskable	0FFE2h	1
Basic Timer1	BTIFG	Maskable	0FFE0h	0, lowest

(1) Multiple source flags

(2) (Non)maskable: the individual interrupt-enable bit can disable an interrupt event, but the general-interrupt enable cannot disable it.

(3) Interrupt flags are located in the module.

## 9.5 Special Function Registers (SFRs)

The MSP430 SFRs are located in the lowest address space and are organized as byte-mode registers. SFRs should be accessed with byte instructions.

### Legend

- rw Bit can be read and written.
- rw-0, rw-1 Bit can be read and written. It is Reset or Set by PUC.
- rw-(0), rw-1 Bit can be read and written. It is Reset or Set by POR.
- SFR bit is not present in device.

### 9.5.1 Interrupt Enable Registers 1 and 2

**Figure 9-1. Interrupt Enable Register 1 (Address = 0h)**

7	6	5	4	3	2	1	0
UTXIE0	URXIE0	ACCVIE	NMIIE	<span style="background-color: #cccccc; display: inline-block; width: 1em; height: 1em;"></span>	<span style="background-color: #cccccc; display: inline-block; width: 1em; height: 1em;"></span>	OFIE	WDTIE
rw-0	rw-0	rw-0	rw-0			rw-0	rw-0

**Table 9-4. Interrupt Enable Register 1 Field Descriptions**

BIT	FIELD	TYPE	RESET	DESCRIPTION
7	UTXIE0	RW	0h	USART0: UART and SPI transmit-interrupt enable
6	URXIE0	RW	0h	USART0: UART and SPI receive-interrupt enable
5	ACCVIE	RW	0h	Flash access violation interrupt enable
4	NMIIE	RW	0h	Nonmaskable-interrupt enable
1	OFIE	RW	0h	Oscillator-fault-interrupt enable
0	WDTIE	RW	0h	Watchdog-timer interrupt enable. Inactive if watchdog mode is selected. Active if watchdog timer is configured as a general-purpose timer.

**Figure 9-2. Interrupt Enable Register 2 (Address = 1h)**

7	6	5	4	3	2	1	0
BTIE	<span style="background-color: #cccccc; display: inline-block; width: 1em; height: 1em;"></span>	<span style="background-color: #cccccc; display: inline-block; width: 1em; height: 1em;"></span>	<span style="background-color: #cccccc; display: inline-block; width: 1em; height: 1em;"></span>	<span style="background-color: #cccccc; display: inline-block; width: 1em; height: 1em;"></span>	<span style="background-color: #cccccc; display: inline-block; width: 1em; height: 1em;"></span>	<span style="background-color: #cccccc; display: inline-block; width: 1em; height: 1em;"></span>	<span style="background-color: #cccccc; display: inline-block; width: 1em; height: 1em;"></span>
rw-0							

**Table 9-5. Interrupt Enable Register 2 Field Descriptions**

BIT	FIELD	TYPE	RESET	DESCRIPTION
7	BTIE	RW	0h	Basic timer interrupt enable

### 9.5.2 Interrupt Flag Registers 1 and 2

**Figure 9-3. Interrupt Flag Register 1 (Address = 2h)**

7	6	5	4	3	2	1	0
UTXIFG0	URXIFG0		NMIIFG			OFIFG	WDTIFG
rw-1	rw-0		rw-0			rw-1	rw-(0)

**Table 9-6. Interrupt Flag Register 1 Field Descriptions**

BIT	FIELD	TYPE	RESET	DESCRIPTION
7	UTXIFG0	RW	1h	USART0: UART and SPI transmit flag
6	URXIFG0	RW	0h	USART0: UART and SPI receive flag
4	NMIIFG	RW	0h	Set by $\overline{RST}$ /NMI pin
1	OFIFG	RW	1h	Flag set on oscillator fault
0	WDTIFG	RW	0h	Set on watchdog timer overflow (in watchdog mode) or security key violation Reset on $V_{CC}$ power-on or a reset condition at the $\overline{RST}$ /NMI pin in reset mode

**Figure 9-4. Interrupt Flag Register 2 (Address = 3h)**

7	6	5	4	3	2	1	0
BTIFG							
rw-0							

**Table 9-7. Interrupt Flag Register 2 Field Descriptions**

BIT	FIELD	TYPE	RESET	DESCRIPTION
7	BTIFG	RW	0h	Basic timer flag

### 9.5.3 Module Enable Registers 1 and 2

**Figure 9-5. Module Enable Register 1 (Address = 4h)**

7	6	5	4	3	2	1	0
UTXE0	URXE0 USPIE0						
rw-0	rw-0						

**Table 9-8. Module Enable Register 1 Field Descriptions**

BIT	FIELD	TYPE	RESET	DESCRIPTION
7	UTXE0	RW	0h	USART0: UART mode transmit enable
6	URXE0	RW	0h	USART0: UART mode receive enable
	USPIE0	RW	0h	USART0: SPI mode transmit and receive enable

**Figure 9-6. Module Enable Register 2 (Address = 5h)**

7	6	5	4	3	2	1	0

## 9.6 Memory Organization

Table 9-9 shows the memory organization for all device variants.

**Table 9-9. Memory Organization**

		<b>MSP430FG437</b>	<b>MSP430FG438</b>	<b>MSP430FG439</b>
Memory	Size	32KB	48KB	60KB
Main: interrupt vector	Flash	0FFFFh-0FFE0h	0FFFFh-0FFE0h	0FFFFh-0FFE0h
Main: code memory	Flash	0FFFFh-08000h	0FFFFh-04000h	0FFFFh-01100h
Information memory	Size	256 Byte	256 Byte	256 Byte
	Flash	010FFh-01000h	010FFh-01000h	010FFh-01000h
Boot memory	Size	1KB	1KB	1KB
	ROM	0FFFh-0C00h	0FFFh-0C00h	0FFFh-0C00h
RAM	Size	1KB	2KB	2KB
		05FFh-0200h	09FFh-0200h	09FFh-0200h
Peripherals	16-bit	01FFh-0100h	01FFh-0100h	01FFh-0100h
	8-bit	0FFh-010h	0FFh-010h	0FFh-010h
	8-bit SFR	0Fh-00h	0Fh-00h	0Fh-00h

### 9.7 Bootstrap Loader (BSL)

The MSP430 bootstrap loader (BSL) enables users to program the flash memory or RAM using a UART serial interface. Access to the MSP430 memory via the BSL is protected by user-defined password. For complete description of the features of the BSL and its implementation, see *MSP430 Programming Via the Bootstrap Loader (BSL)* (SLAU319).

BSL FUNCTION	PN PACKAGE PINS	ZCA PACKAGE PINS
Data Transmit	67 – P1.0	D8 – P1.0
Data Receiver	66 – P1.1	D9 – P1.1

### 9.8 Flash Memory

The flash memory can be programmed via the JTAG port, the bootstrap loader, or in system by the CPU. The CPU can perform single-byte and single-word writes to the flash memory. Features of the flash memory include:

- Flash memory has n segments of main memory and two segments of information memory (A and B) of 128 bytes each. Each segment in main memory is 512 bytes in size.
- Segments 0 to n may be erased in one step, or each segment may be individually erased.
- Segments A and B can be erased individually, or as a group with segments 0 to n. Segments A and B are also called information memory.
- New devices may have some bytes programmed in the information memory (needed for test during manufacturing). The user should perform an erase of the information memory prior to the first use.

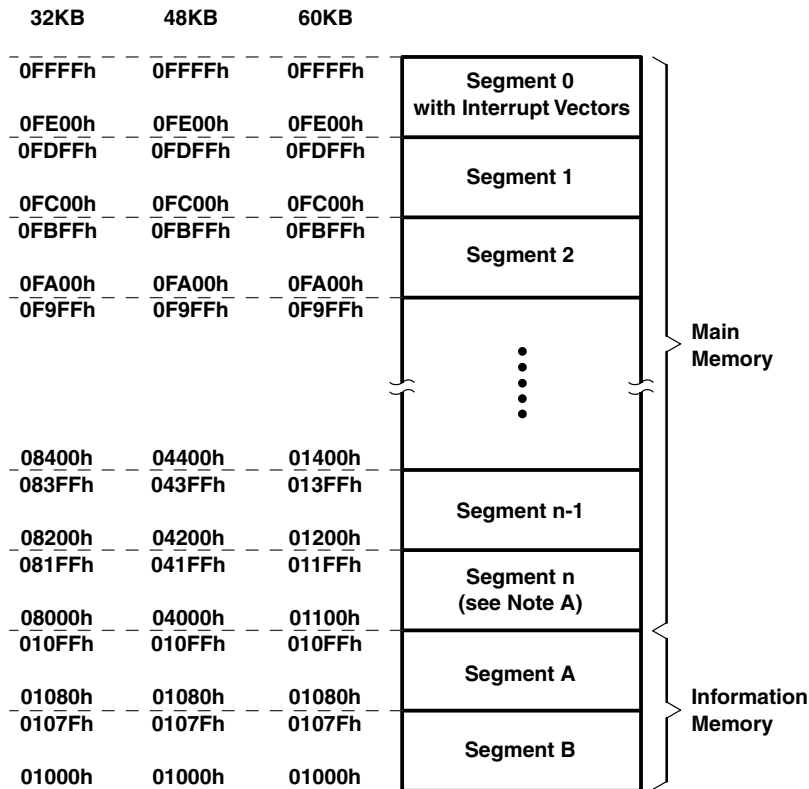

A. MSP430FG43x flash segment n = 256 bytes.

**Figure 9-7. Flash Memory Segments**

## 9.9 Peripherals

Peripherals are connected to the CPU through data, address, and control buses and can be handled using all instructions. For complete module descriptions, see the *MSP430x4xx Family User's Guide* (SLAU056).

### 9.9.1 DMA Controller

The DMA controller allows movement of data from one memory address to another without CPU intervention. For example, the DMA controller can be used to move data from the ADC12 conversion memory to RAM. Using the DMA controller can increase the throughput of peripheral modules. The DMA controller reduces system power consumption by allowing the CPU to remain in sleep mode without having to awaken to move data to or from a peripheral.

### 9.9.2 Oscillator and System Clock

The clock system in the MSP430FG43x family of devices is supported by the FLL+ module, which includes support for a 32768-Hz watch crystal oscillator, an internal digitally-controlled oscillator (DCO), and a high frequency crystal oscillator. The FLL+ clock module is designed to meet the requirements of both low system cost and low power consumption. The FLL+ features digital frequency locked loop (FLL) hardware that, in conjunction with a digital modulator, stabilizes the DCO frequency to a programmable multiple of the watch crystal frequency. The internal DCO provides a fast turn-on clock source and stabilizes in less than 6  $\mu$ s. The FLL+ module provides the following clock signals:

- Auxiliary clock (ACLK), sourced from a 32768-Hz watch crystal or a high-frequency crystal
- Main clock (MCLK), the system clock used by the CPU
- Sub-Main clock (SMCLK), the subsystem clock used by the peripheral modules
- ACLK/n, the buffered output of ACLK, ACLK/2, ACLK/4, or ACLK/8

### 9.9.3 Brownout, Supply Voltage Supervisor

The brownout circuit is implemented to provide the proper internal reset signal to the device during power-on and power-off. The supply voltage supervisor (SVS) circuitry detects if the supply voltage drops below a user selectable level and supports both supply voltage supervision (the device is automatically reset) and supply voltage monitoring (the device is not automatically reset).

The CPU begins code execution after the brownout circuit releases the device reset. However,  $V_{CC}$  may not have ramped to  $V_{CC(min)}$  at that time. The user must make sure that the default FLL+ settings are not changed until  $V_{CC}$  reaches  $V_{CC(min)}$ . If desired, the SVS circuit can be used to determine when  $V_{CC}$  reaches  $V_{CC(min)}$ .

### 9.9.4 Digital I/O

There are six 8-bit I/O ports implemented—ports P1 through P6:

- All individual I/O bits are independently programmable.
- Any combination of input, output, and interrupt conditions is possible.
- Edge-selectable interrupt input capability for all the eight bits of ports P1 and P2.
- Read and write access to port-control registers is supported by all instructions

### 9.9.5 Basic Timer1

The Basic Timer1 has two independent 8-bit timers that can be cascaded to form a 16-bit timer/counter. Both timers can be read and written by software. The Basic Timer1 can be used to generate periodic interrupts and clock for the LCD module.

### 9.9.6 LCD Drive

The LCD driver generates the segment and common signals required to drive an LCD display. The LCD controller has dedicated data memory to hold segment drive information. Common and segment signals are generated as defined by the mode. Static, 2-MUX, 3-MUX, and 4-MUX LCDs are supported by this peripheral.

### 9.9.7 OA

The MSP430FG43x has three configurable low-current general-purpose operational amplifiers. Each OA input and output terminal is software-selectable and offers a flexible choice of connections for various applications. The OA op amps primarily support front-end analog signal conditioning prior to analog-to-digital conversion.

### 9.9.8 Watchdog Timer (WDT)

The primary function of the WDT module is to perform a controlled system restart after a software problem occurs. If the selected time interval expires, a system reset is generated. If the watchdog function is not needed in an application, the module can be configured as an interval timer and can generate interrupts at selected time intervals.

### 9.9.9 USART0

The MSP430FG43x has one hardware universal synchronous/asynchronous receive transmit (USART) peripheral module that is used for serial data communication. The USART supports synchronous SPI (3 or 4 pin) and asynchronous UART communication protocols, using double-buffered transmit and receive channels.

### 9.9.10 Timer\_A3

Timer\_A3 is a 16-bit timer/counter with three capture/compare registers. Timer\_A3 can support multiple capture/compares, PWM outputs, and interval timing. Timer\_A3 also has extensive interrupt capabilities. Interrupts may be generated from the counter on overflow conditions and from each of the capture/compare registers.

**Table 9-10. Timer\_A3 Signal Connections**

INPUT PIN NUMBER		DEVICE INPUT SIGNAL	MODULE INPUT NAME	MODULE BLOCK	MODULE OUTPUT SIGNAL	OUTPUT PIN NUMBER	
ZCA	PN					PN	ZCA
B10 - P1.5	62 - P1.5	TACLK	TACLK				
		ACLK	ACLK				
		SMCLK	SMCLK	Timer	NA		
B10 - P1.5	62 - P1.5	TACLK	INCLK				
D8 - P1.0	67 - P1.0	TA0	CCI0A			67 - P1.0	D8 - P1.0
D9 - P1.1	66 - P1.1	TA0	CCI0B				
		DVSS	GND	CCR0	TA0		
		DVCC	VCC				
B9 - P1.2	65 - P1.2	TA1	CCI1A			65 - P1.2	B9 - P1.2
		CAOUT (internal)	CCI1B			ADC12 (internal)	
		DVSS	GND	CCR1	TA1		
		DVCC	VCC				
C11 - P2.0	59 - P2.0	TA2	CCI2A			59 - P2.0	C11 - P2.0
		ACLK (internal)	CCI2B				
		DVSS	GND	CCR2	TA2		
		DVCC	VCC				

### 9.9.11 Timer\_B3

Timer\_B3 is a 16-bit timer/counter with three capture/compare registers. Timer\_B3 can support multiple capture/compares, PWM outputs, and interval timing. Timer\_B3 also has extensive interrupt capabilities. Interrupts may be generated from the counter on overflow conditions and from each of the capture/compare registers.

**Table 9-11. Timer\_B3 Signal Connections**

INPUT PIN NUMBER		DEVICE INPUT SIGNAL	MODULE INPUT NAME	MODULE BLOCK	MODULE OUTPUT SIGNAL	OUTPUT PIN NUMBER	
ZCA	PN					PN	ZCA
E9 - P1.4	63 - P1.4	TBCLK	TBCLK				
		ACLK	ACLK				
		SMCLK	SMCLK	Timer	NA		
E9 - P1.4	63 - P1.4	TBCLK	INCLK				
D11 - P2.1	58 - P2.1	TB0	CCI0A			58 - P2.1	D11 - P2.1
D11 - P2.1	58 - P2.1	TB0	CCI0B			ADC12 (internal)	
		DVSS	GND	CCR0	TB0		
		DVCC	VCC				
E11 - P2.2	57 - P2.2	TB1	CCI1A			57 - P2.2	E11 - P2.2
E11 - P2.2	57 - P2.2	TB1	CCI1B			ADC12 (internal)	
		DVSS	GND	CCR1	TB1		
		DVCC	VCC				
F11 - P2.3	56 - P2.3	TB2	CCI2A			56 - P2.3	F11 - P2.3
F11 - P2.3	56 - P2.3	TB2	CCI2B				
		DVSS	GND	CCR2	TB2		
		DVCC	VCC				

### 9.9.12 Comparator\_A

The primary function of the comparator\_A module is to support precision slope analog-to-digital conversions, battery-voltage supervision, and monitoring of external analog signals.

### 9.9.13 ADC12

The ADC12 module supports fast, 12-bit analog-to-digital conversions. The module implements a 12-bit SAR core, sample select control, reference generator and a 16 word conversion-and-control buffer. The conversion-and-control buffer allows up to 16 independent ADC samples to be converted and stored without any CPU intervention.

### 9.9.14 DAC12

The DAC12 module is a 12-bit, R-ladder, voltage output DAC. The DAC12 may be used in 8- or 12-bit mode, and may be used in conjunction with the DMA controller. When multiple DAC12 modules are present, they may be grouped together for synchronous operation.

### 9.9.15 Peripheral File Map

Table 9-12 shows peripherals with word-access registers, and Table 9-13 shows peripherals with byte-access registers.

**Table 9-12. Peripherals With Word Access**

PERIPHERAL	REGISTER NAME	ACRONYM	OFFSET
Watchdog	Watchdog timer control	WDTCTL	0120h
Timer_B3	Capture/compare register 2	TBCCR2	0196h
	Capture/compare register 1	TBCCR1	0194h
	Capture/compare register 0	TBCCR0	0192h
	Timer_B register	TBR	0190h
	Capture/compare control 2	TBCCTL2	0186h
	Capture/compare control 1	TBCCTL1	0184h
	Capture/compare control 0	TBCCTL0	0182h
	Timer_B control	TBCTL	0180h
	Timer_B interrupt vector	TBIV	011Eh
	Capture/compare register 2	TACCR2	0176h
	Capture/compare register 1	TACCR1	0174h
	Capture/compare register 0	TACCR0	0172h
Timer_A3	Timer_A register	TAR	0170h
	Capture/compare control 2	TACCTL2	0166h
	Capture/compare control 1	TACCTL1	0164h
	Capture/compare control 0	TACCTL0	0162h
	Timer_A control	TACTL	0160h
	Timer_A interrupt vector	TAIV	012Eh
Flash	Flash control 3	FCTL3	012Ch
	Flash control 2	FCTL2	012Ah
	Flash control 1	FCTL1	0128h
DMA	DMA module control 0	DMACTL0	0122h
	DMA module control 1	DMACTL1	0124h
	DMA channel 0 control	DMA0CTL	01E0h
	DMA channel 0 source address	DMA0SA	01E2h
	DMA channel 0 destination address	DMA0DA	01E4h
	DMA channel 0 transfer size	DMA0SZ	01E6h

**Table 9-12. Peripherals With Word Access (continued)**

PERIPHERAL	REGISTER NAME	ACRONYM	OFFSET
ADC12 (See also <a href="#">Table 9-13</a> )	Conversion memory 15	ADC12MEM15	015Eh
	Conversion memory 14	ADC12MEM14	015Ch
	Conversion memory 13	ADC12MEM13	015Ah
	Conversion memory 12	ADC12MEM12	0158h
	Conversion memory 11	ADC12MEM11	0156h
	Conversion memory 10	ADC12MEM10	0154h
	Conversion memory 9	ADC12MEM9	0152h
	Conversion memory 8	ADC12MEM8	0150h
	Conversion memory 7	ADC12MEM7	014Eh
	Conversion memory 6	ADC12MEM6	014Ch
	Conversion memory 5	ADC12MEM5	014Ah
	Conversion memory 4	ADC12MEM4	0148h
	Conversion memory 3	ADC12MEM3	0146h
	Conversion memory 2	ADC12MEM2	0144h
	Conversion memory 1	ADC12MEM1	0142h
	Conversion memory 0	ADC12MEM0	0140h
	Interrupt-vector-word register	ADC12IV	01A8h
	Interrupt-enable register	ADC12IE	01A6h
	Interrupt-flag register	ADC12IFG	01A4h
	Control register 1	ADC12CTL1	01A2h
Control register 0	ADC12CTL0	01A0h	
DAC12	DAC12_1 data	DAC12_1DAT	01CAh
	DAC12_1 control	DAC12_1CTL	01C2h
	DAC12_0 data	DAC12_0DAT	01C8h
	DAC12_0 control	DAC12_0CTL	01C0h

**Table 9-13. Peripherals With Byte Access**

PERIPHERAL	REGISTER NAME	ACRONYM	OFFSET
OA2	Operational Amplifier 2 control register 1	OA2CTL1	0C5h
	Operational Amplifier 2 control register 0	OA2CTL0	0C4h
OA1	Operational Amplifier 1 control register 1	OA1CTL1	0C3h
	Operational Amplifier 1 control register 0	OA1CTL0	0C2h
OA0	Operational Amplifier 0 control register 1	OA0CTL1	0C1h
	Operational Amplifier 0 control register 0	OA0CTL0	0C0h
LCD	LCD memory 20	LCDM20	0A4h
	⋮	⋮	⋮
	LCD memory 16	LCDM16	0A0h
	LCD memory 15	LCDM15	09Fh
	⋮	⋮	⋮
	LCD memory 1	LCDM1	091h
	LCD control and mode	LCDCTL	090h

**Table 9-13. Peripherals With Byte Access (continued)**

PERIPHERAL	REGISTER NAME	ACRONYM	OFFSET
ADC12 (Memory control registers require byte access)	ADC memory-control register 15	ADC12MCTL15	08Fh
	ADC memory-control register 14	ADC12MCTL14	08Eh
	ADC memory-control register 13	ADC12MCTL13	08Dh
	ADC memory-control register 12	ADC12MCTL12	08Ch
	ADC memory-control register 11	ADC12MCTL11	08Bh
	ADC memory-control register 10	ADC12MCTL10	08Ah
	ADC memory-control register 9	ADC12MCTL9	089h
	ADC memory-control register 8	ADC12MCTL8	088h
	ADC memory-control register 7	ADC12MCTL7	087h
	ADC memory-control register 6	ADC12MCTL6	086h
	ADC memory-control register 5	ADC12MCTL5	085h
	ADC memory-control register 4	ADC12MCTL4	084h
	ADC memory-control register 3	ADC12MCTL3	083h
	ADC memory-control register 2	ADC12MCTL2	082h
	ADC memory-control register 1	ADC12MCTL1	081h
ADC memory-control register 0	ADC12MCTL0	080h	
USART0 (UART or SPI mode)	Transmit buffer	U0TXBUF	077h
	Receive buffer	U0RXBUF	076h
	Baud rate	U0BR1	075h
	Baud rate	U0BR0	074h
	Modulation control	U0MCTL	073h
	Receive control	U0RCTL	072h
	Transmit control	U0TCTL	071h
	USART control	U0CTL	070h
Comparator_A	Comparator_A port disable	CAPD	05Bh
	Comparator_A control 2	CACTL2	05Ah
	Comparator_A control 1	CACTL1	059h
BrownOUT, SVS	SVS control register (Reset by brownout signal)	SVSCTL	056h
FLL+ Clock	FLL+ Control 1	FLL_CTL1	054h
	FLL+ Control 0	FLL_CTL0	053h
	System clock frequency control	SCFQCTL	052h
	System clock frequency integrator	SCF11	051h
	System clock frequency integrator	SCF10	050h
Basic Timer1	BT counter 2	BTCNT2	047h
	BT counter 1	BTCNT1	046h
	BT control	BTCTL	040h
Port P6	Port P6 selection	P6SEL	037h
	Port P6 direction	P6DIR	036h
	Port P6 output	P6OUT	035h
	Port P6 input	P6IN	034h
Port P5	Port P5 selection	P5SEL	033h
	Port P5 direction	P5DIR	032h
	Port P5 output	P5OUT	031h
	Port P5 input	P5IN	030h

**Table 9-13. Peripherals With Byte Access (continued)**

PERIPHERAL	REGISTER NAME	ACRONYM	OFFSET
Port P4	Port P4 selection	P4SEL	01Fh
	Port P4 direction	P4DIR	01Eh
	Port P4 output	P4OUT	01Dh
	Port P4 input	P4IN	01Ch
Port P3	Port P3 selection	P3SEL	01Bh
	Port P3 direction	P3DIR	01Ah
	Port P3 output	P3OUT	019h
	Port P3 input	P3IN	018h
Port P2	Port P2 selection	P2SEL	02Eh
	Port P2 interrupt enable	P2IE	02Dh
	Port P2 interrupt-edge select	P2IES	02Ch
	Port P2 interrupt flag	P2IFG	02Bh
	Port P2 direction	P2DIR	02Ah
	Port P2 output	P2OUT	029h
	Port P2 input	P2IN	028h
Port P1	Port P1 selection	P1SEL	026h
	Port P1 interrupt enable	P1IE	025h
	Port P1 interrupt-edge select	P1IES	024h
	Port P1 interrupt flag	P1IFG	023h
	Port P1 direction	P1DIR	022h
	Port P1 output	P1OUT	021h
	Port P1 input	P1IN	020h
Special functions	SFR module enable 2	ME2	005h
	SFR module enable 1	ME1	004h
	SFR interrupt flag 2	IFG2	003h
	SFR interrupt flag 1	IFG1	002h
	SFR interrupt enable 2	IE2	001h
	SFR interrupt enable 1	IE1	000h

## 9.10 Input/Output Schematics

### 9.10.1 Port P1, P1.0 to P1.5, Input/Output With Schmitt Trigger

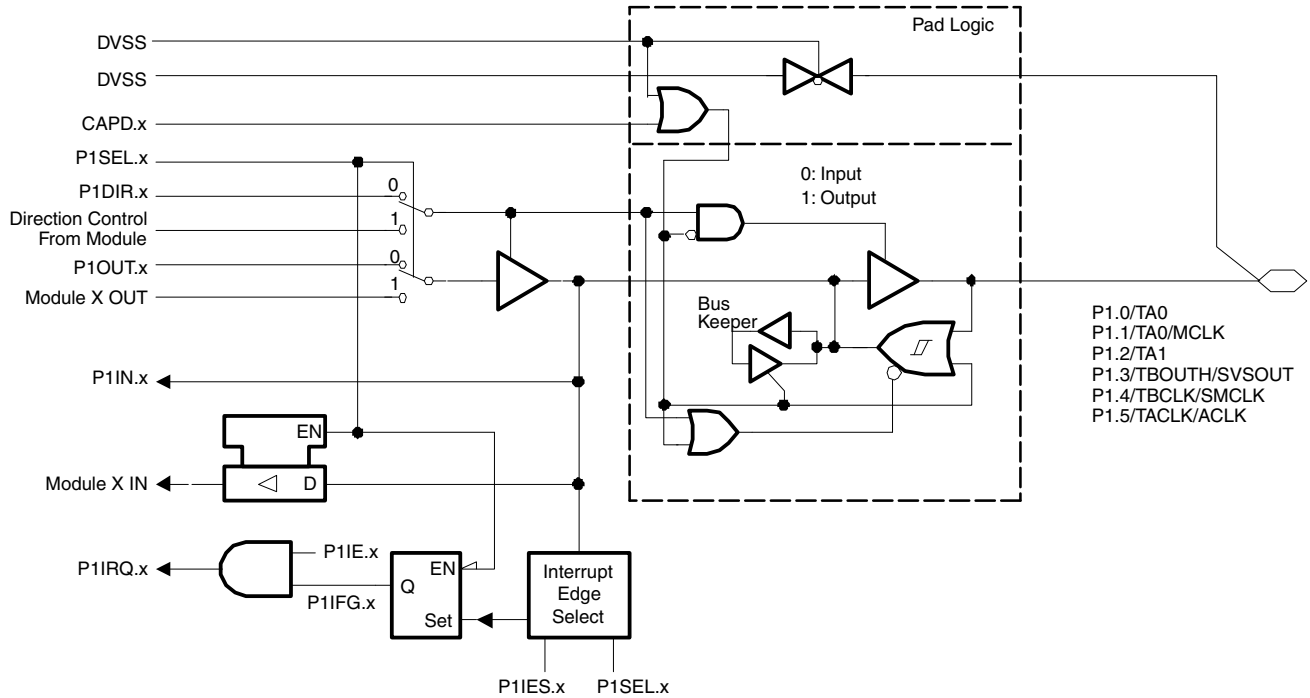

Note:  $0 \leq x \leq 5$   
Note: Port function is active if CAPD.x = 0

PnSEL.x	PnDIR.x	Direction Control From Module	PnOUT.x	Module X OUT	PnIN.x	Module X IN	PnIE.x	PnIFG.x	PnIES.x
P1SEL.0	P1DIR.0	P1DIR.0	P1OUT0	Out0 sig. <sup>(1)</sup>	P1IN.0	CCI0A <sup>(1)</sup>	P1IE.0	P1IFG.0	P1IES.0
P1SEL.1	P1DIR.1	P1DIR.1	P1OUT.1	MCLK	P1IN.1	CCI0B <sup>(1)</sup>	P1IE.1	P1IFG.1	P1IES.1
P1SEL.2	P1DIR.2	P1DIR.2	P1OUT.2	Out1 sig. <sup>(1)</sup>	P1IN.2	CCI1A <sup>(1)</sup>	P1IE.2	P1IFG.2	P1IES.2
P1SEL.3	P1DIR.3	P1DIR.3	P1OUT.3	SVSOUT	P1IN.3	TBOUTH <sup>(2)</sup>	P1IE.3	P1IFG.3	P1IES.3
P1SEL.4	P1DIR.4	P1DIR.4	P1OUT.4	SMCLK	P1IN.4	TBCLK <sup>(2)</sup>	P1IE.4	P1IFG.4	P1IES.4
P1SEL.5	P1DIR.5	P1DIR.5	P1OUT.5	ACLK	P1IN.5	TACLK <sup>(1)</sup>	P1IE.5	P1IFG.5	P1IES.5

- (1) Timer\_A
- (2) Timer\_B

### 9.10.2 Port P1, P1.6 and P1.7, Input/Output With Schmitt Trigger

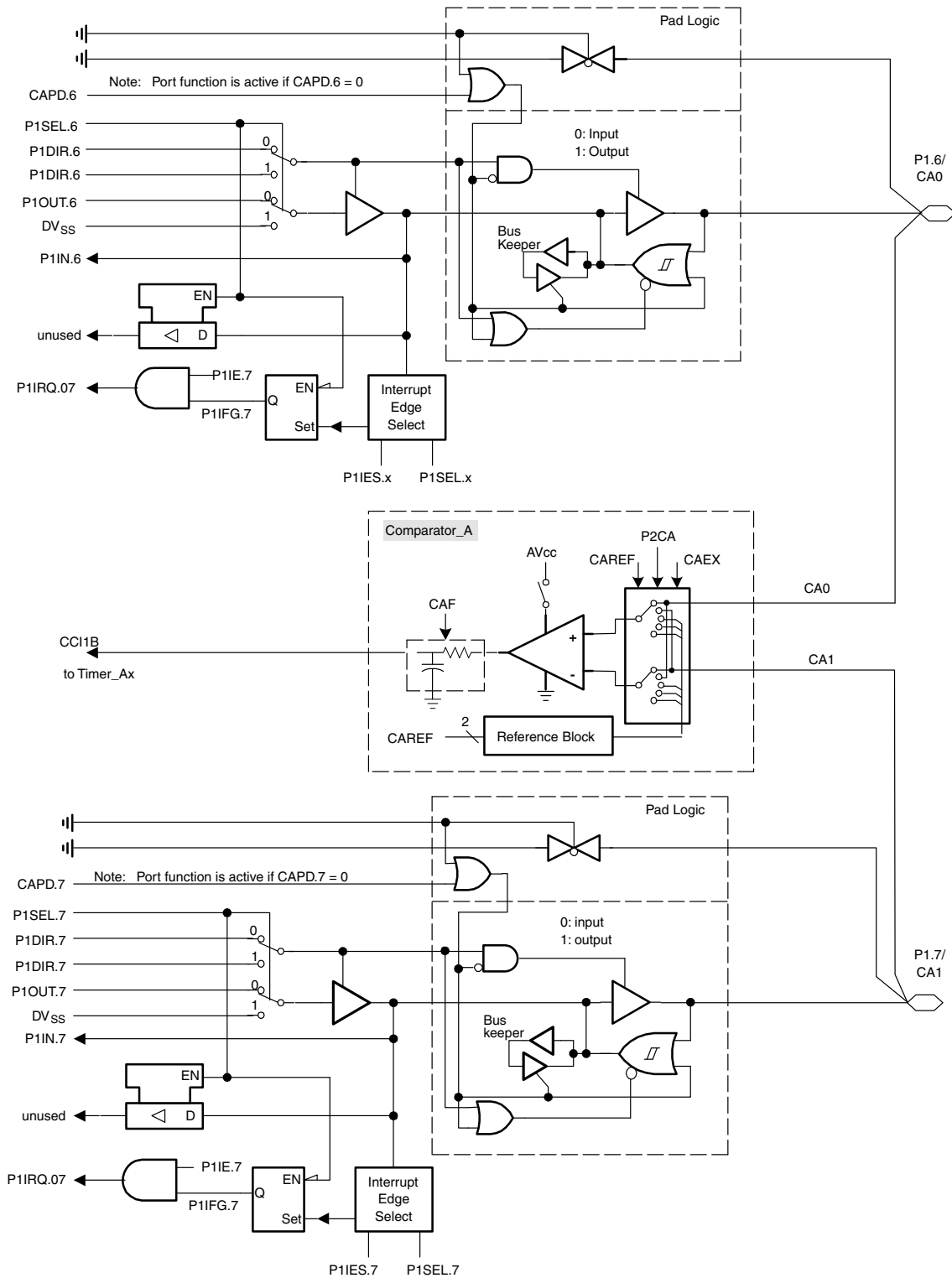

### 9.10.3 Port P2, P2.0 and P2.4 to P2.5, Input/Output With Schmitt Trigger

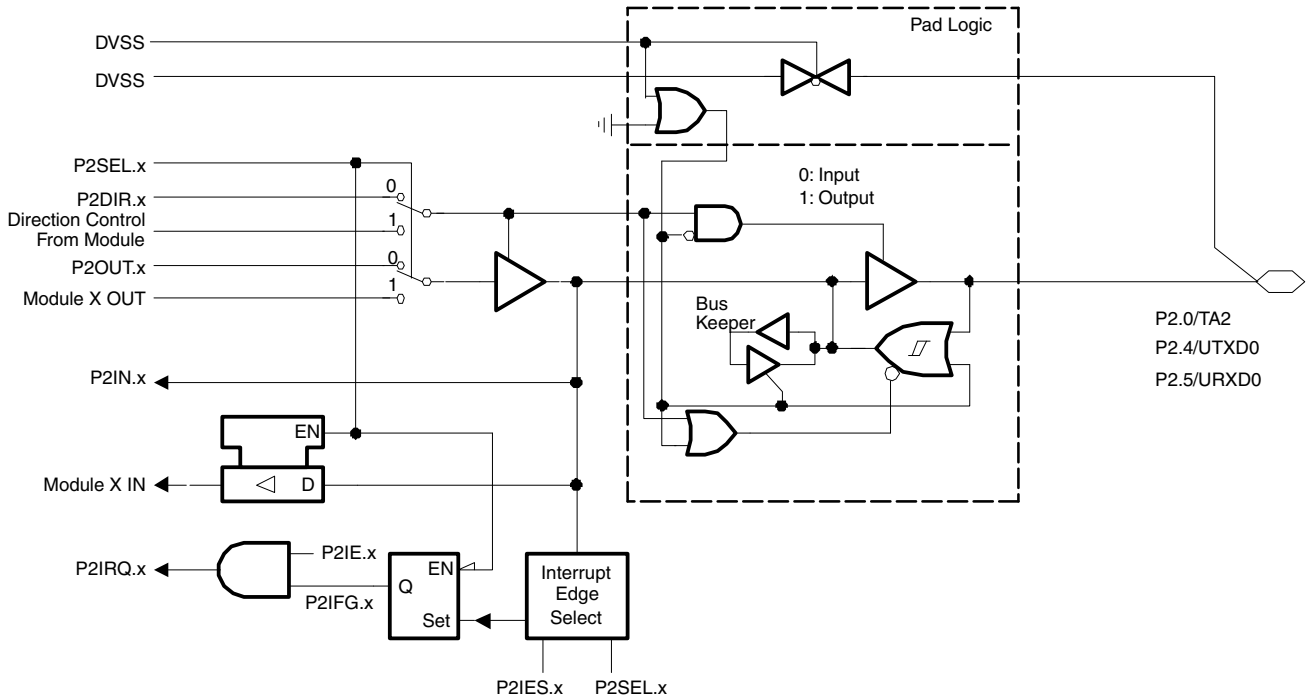

Note: x {0,4,5}

PnSel.x	PnDIR.x	Direction Control From Module	PnOUT.x	Module X OUT	PnIN.x	Module X IN	PnIE.x	PnIFG.x	PnIES.x
P2Sel.0	P2DIR.0	P2DIR.0	P2OUT.0	Out2 sig. <sup>(1)</sup>	P2IN.0	CCI2A <sup>(1)</sup>	P2IE.0	P2IFG.0	P2IES.0
P2Sel.4	P2DIR.4	DVCC	P2OUT.4	UTXD0 <sup>(2)</sup>	P2IN.4	unused	P2IE.4	P2IFG.4	P2IES.4
P2Sel.5	P2DIR.5	DVSS	P2OUT.5	DVSS	P2IN.5	URXD0 <sup>(2)</sup>	P2IE.5	P2IFG.5	P2IES.5

- (1) Timer\_A
- (2) USART0

### 9.10.4 Port P2, P2.1 to P2.3, Input/Output With Schmitt Trigger

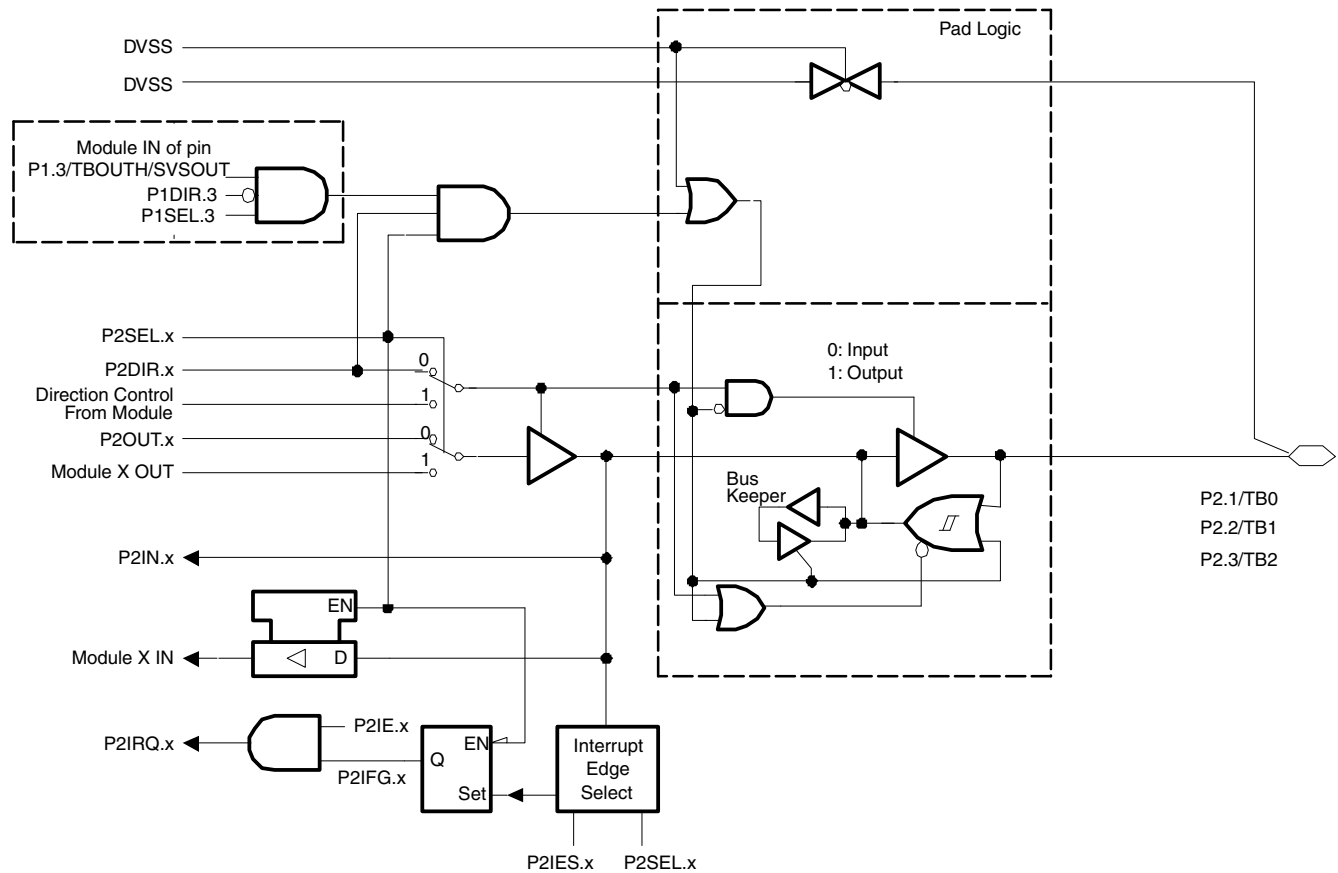

Note:  $1 \leq x \leq 3$

PnSel.x	PnDIR.x	Direction Control From Module	PnOUT.x	Module X OUT	PnIN.x	Module X IN	PnIE.x	PnIFG.x	PnIES.x
P2Sel.1	P2DIR.1	P2DIR.1	P2OUT.1	Out0 sig. <sup>(1)</sup>	P2IN.1	CCI0A <sup>(1)</sup> CCI0B	P2IE.1	P2IFG.1	P2IES.1
P2Sel.2	P2DIR.2	P2DIR.2	P2OUT.2	Out1 sig. <sup>(1)</sup>	P2IN.2	CCI1A <sup>(1)</sup> CCI1B	P2IE.2	P2IFG.2	P2IES.2
P2Sel.3	P2DIR.3	P2DIR.3	P2OUT.3	Out2 sig. <sup>(1)</sup>	P2IN.3	CCI2A <sup>(1)</sup> CCI2B	P2IE.3	P2IFG.3	P2IES.3

(1) Timer\_B

### 9.10.5 Port P2, P2.6 and P2.7, Input/Output With Schmitt Trigger

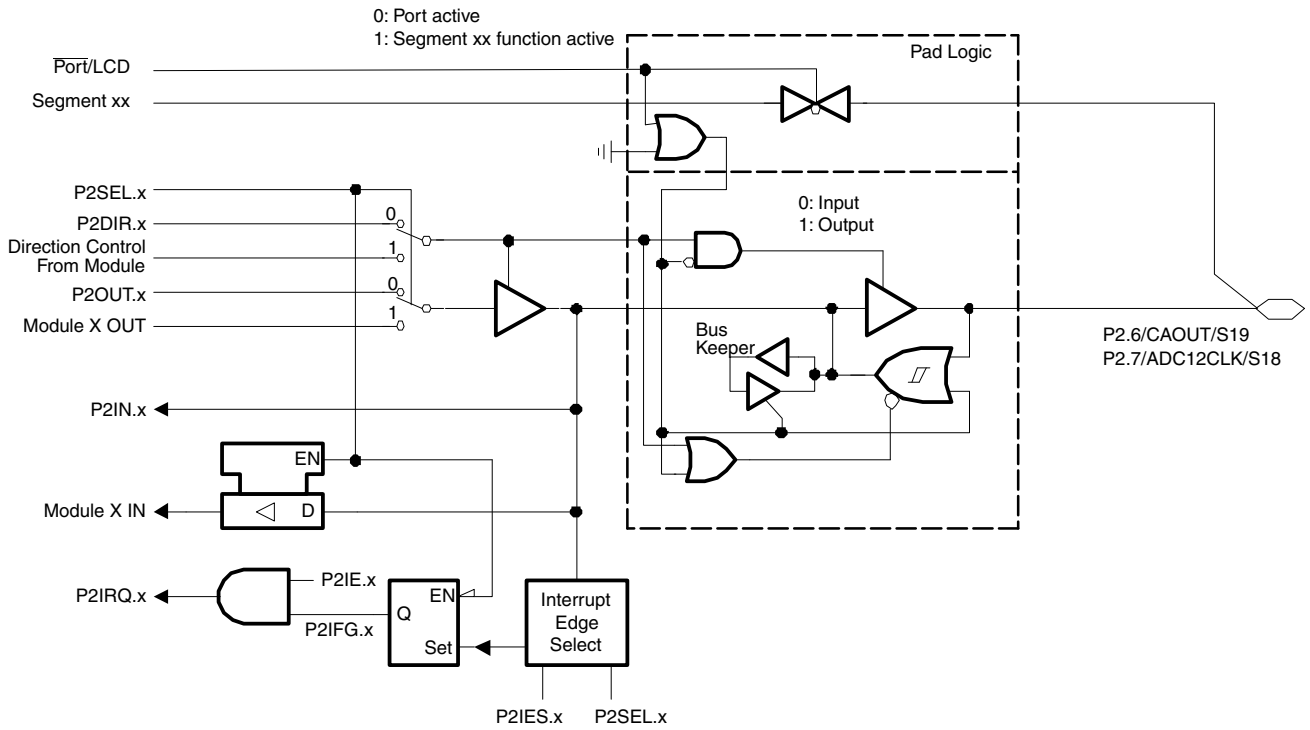

PnSel.x	PnDIR.x	Direction Control From Module	PnOUT.x	Module X OUT	PnIN.x	Module X IN	PnIE.x	PnIFG.x	PnIES.x	Port/LCD
P2Sel.6	P2DIR.6	P2DIR.6	P2OUT.6	CAOUT <sup>(1)</sup>	P2IN.6	unused	P2IE.6	P2IFG.6	P2IES.6	0: LCDP <sub>x</sub> < 02h
P2Sel.7	P2DIR.7	P2DIR.7	P2OUT.7	ADC12CLK <sup>(2)</sup>	P2IN.7	unused	P2IE.7	P2IFG.7	P2IES.7	0: LCDP <sub>x</sub> < 02h

- (1) Comparator\_A
- (2) ADC12

### 9.10.6 Port P3, P3.0 to P3.3, Input/Output With Schmitt Trigger

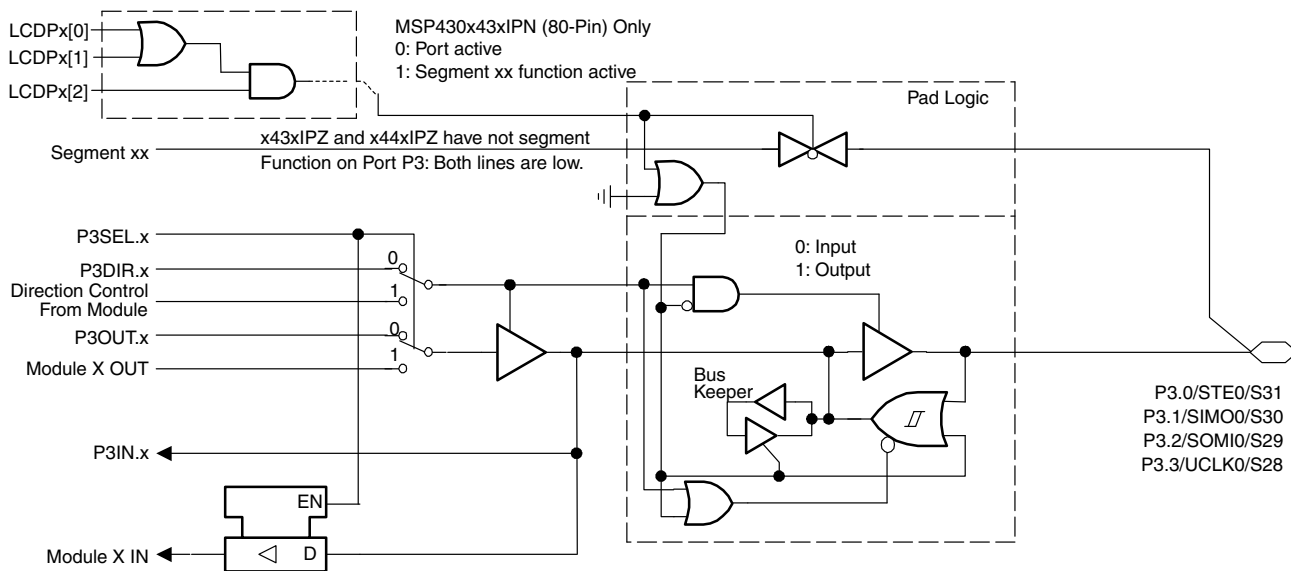

Note:  $0 \leq x \leq 3$

PnSel.x	PnDIR.x	Direction Control From Module	PnOUT.x	Module X OUT	PnIN.x	Module X IN
P3Sel.0	P3DIR.0	DVSS	P3OUT.0	DVSS	P3IN.0	STE0(in)
P3Sel.1	P3DIR.1	DCM_SIMO0	P3OUT.1	SIMO0(out)	P3IN.1	SIMO0(in)
P3Sel.2	P3DIR.2	DCM_SOMI0	P3OUT.2	SOMI0(out)	P3IN.2	SOMI0(in)
P3Sel.3	P3DIR.3	DCM_UCLK0	P3OUT.3	UCLK0(out)	P3IN.3	UCLK0(in)

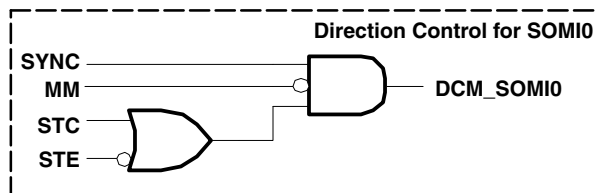
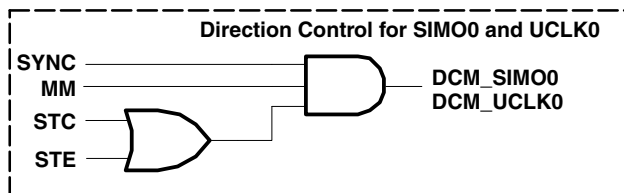

### 9.10.7 Port P3, P3.4 to P3.7, Input/Output With Schmitt Trigger

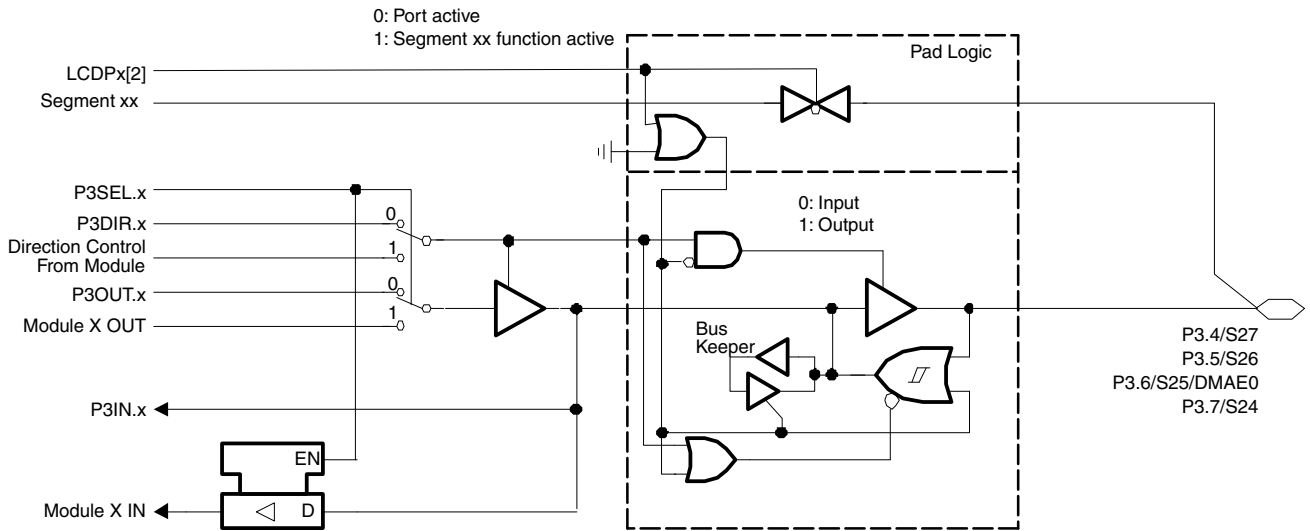

Note:  $4 \leq x \leq 7$

PnSel.x	PnDIR.x	Direction Control From Module	PnOUT.x	Module X OUT	PnIN.x	Module X IN
P3SEL.4	P3DIR.4	P3DIR.4	P3OUT.4	DVSS	P3IN.4	unused
P3SEL.5	P3DIR.5	P3DIR.5	P3OUT.5	DVSS	P3IN.5	unused
P3SEL.6	P3DIR.6	P3DIR.6	P3OUT.6	DVSS	P3IN.6	DMAE0
P3SEL.7	P3DIR.7	P3DIR.7	P3OUT.7	DVSS	P3IN.7	unused

### 9.10.8 Port P4, P4.0 to P4.5, Input/Output With Schmitt Trigger

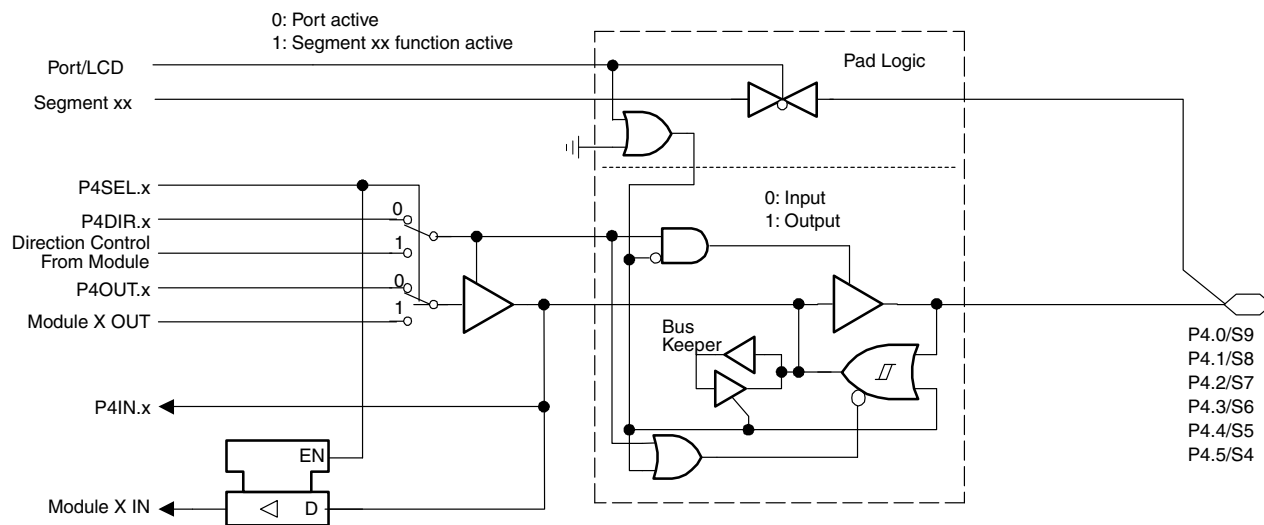
 Note:  $0 \leq x \leq 5$ 

PnSEL.x	PnDIR.x	Direction Control From Module	PnOUT.x	Module X OUT	PnIN.x	Module X IN
P4SEL.0	P4DIR.0	P4DIR.0	P4OUT.0	DVSS	P4IN.0	unused
P4SEL.1	P4DIR.1	P4DIR.1	P4OUT.1	DVSS	P4IN.1	unused
P4SEL.2	P4DIR.2	P4DIR.2	P4OUT.2	DVSS	P4IN.2	unused
P4SEL.3	P4DIR.3	P4DIR.3	P4OUT.3	DVSS	P4IN.3	unused
P4SEL.4	P4DIR.4	P4DIR.4	P4OUT.4	DVSS	P4IN.4	unused
P4SEL.5	P4DIR.5	P4DIR.5	P4OUT.5	DVSS	P4IN.5	unused

DEVICE	PORT BITS	PORT FUNCTION	LCD SEGMENT FUNCTION
MSP430FG43x	P4.0 to P4.5	LCDPx < 01h	LCDPx ≥ 01h

### 9.10.9 Port P4, P4.6, Input/Output With Schmitt Trigger

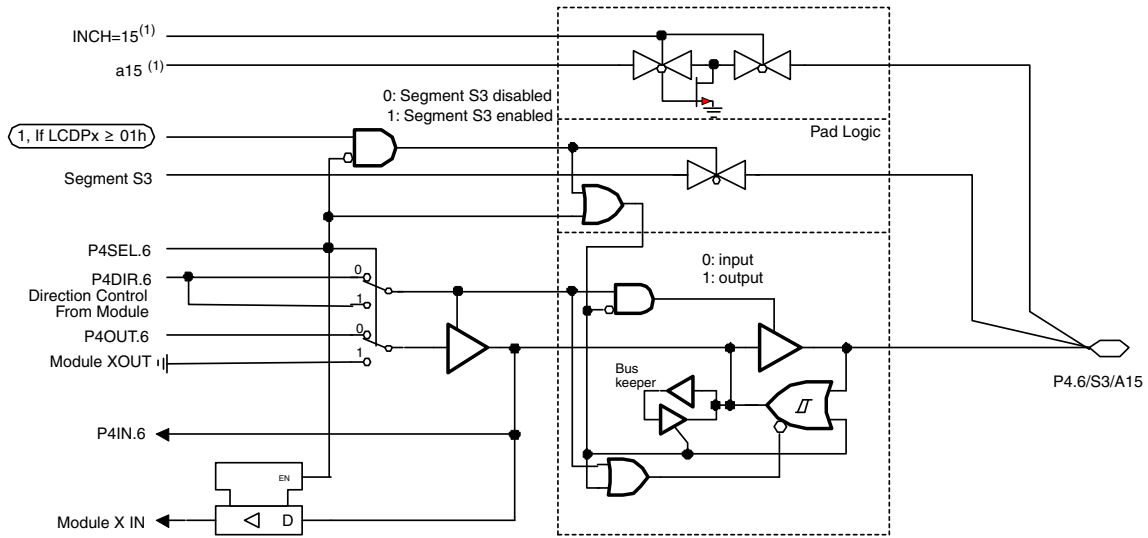

(1) Signal from or to ADC12

PnSEL.x	PnDIR.x	Direction Control From Module	PnOUT.x	Module X OUT	PnIN.x	Module X IN
P4SEL.6	P4DIR.6	P4DIR.6	P4OUT.6	DVSS	P4IN.6	unused

DEVICE	PORT BITS	PORT FUNCTION	LCD SEGMENT FUNCTION
MSP430FG43x	P4.6	LCDPx < 01h	LCDPx ≥ 01h

### 9.10.10 Port P4, P4.7, Input/Output With Schmitt Trigger

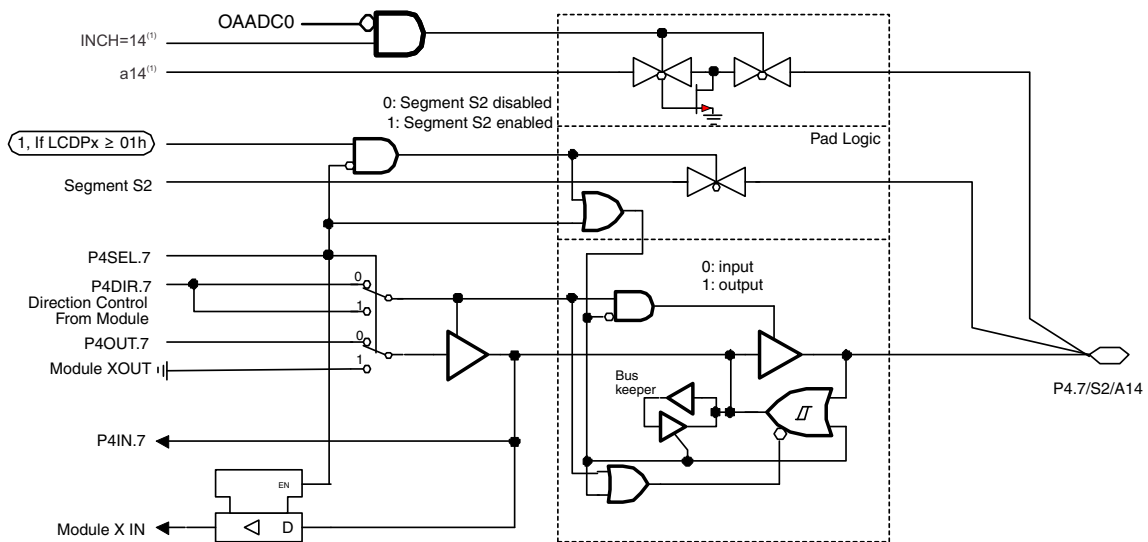

(1) Signal from or to ADC12

PnSel.x	PnDIR.x	Direction Control From Module	PnOUT.x	Module X OUT	PnIN.x	Module X IN
P4Sel.7	P4DIR.7	P4DIR.7	P4OUT.7	DVSS	P4IN.7	Unused

DEVICE	PORT BITS	PORT FUNCTION	LCD SEGMENT FUNCTION
MSP430FG43x	P4.7	LCDPx < 01h	LCDPx ≥ 01h

### 9.10.11 Port P5, P5.0, Input/Output With Schmitt Trigger

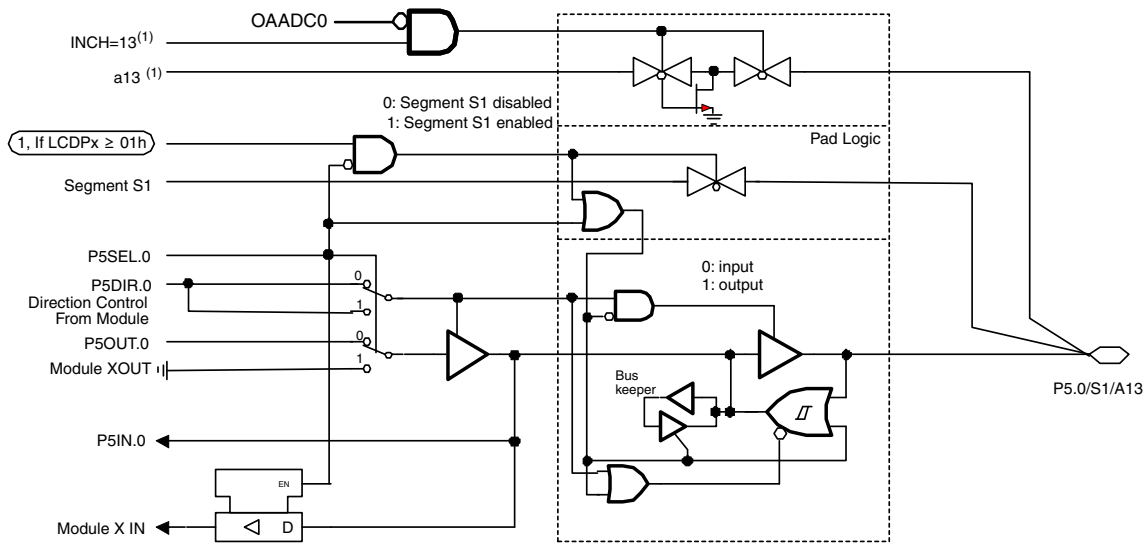

(1) Signal from or to ADC12

PnSEL.x	PnDIR.x	Direction Control From Module	PnOUT.x	Module X OUT	PnIN.x	Module X IN
P5SEL.0	P5DIR.0	P5DIR.0	P5OUT.0	DVSS	P5IN.0	unused

DEVICE	PORT BITS	PORT FUNCTION	LCD SEGMENT FUNCTION
MSP430FG43x	P5.0	LCDPx < 01h	LCDPx ≥ 01h

### 9.10.12 Port P5, P5.1, Input/Output With Schmitt Trigger

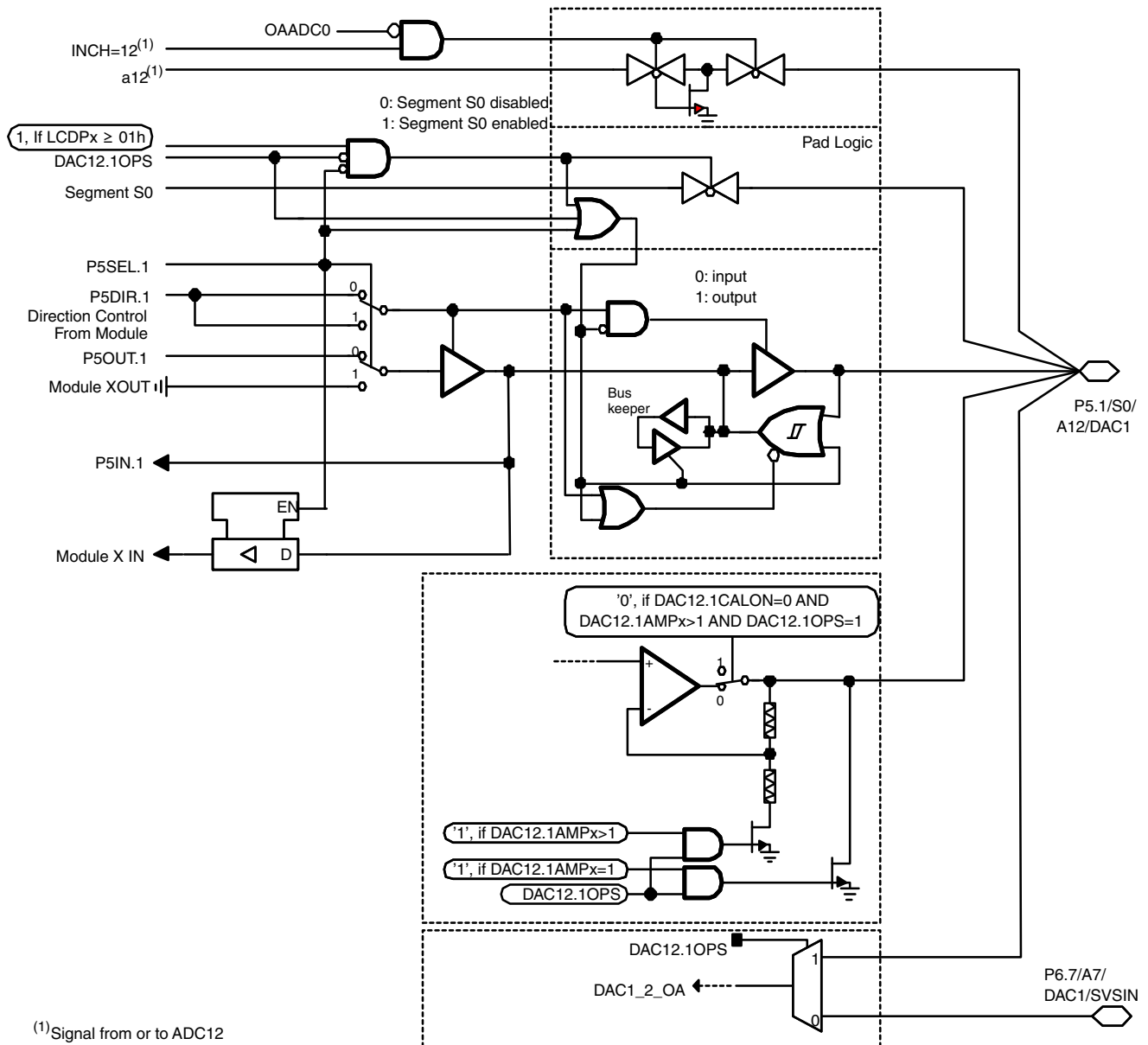

Function	Description	P5SEL.1	LCDPx	DAC12.1OPS	DAC12.1AMPx
DAC12	3-State	X	X	1	0
	0 V	X	X	1	1
	DAC1 output (the output voltage can be converted with ADC12, channel A12)	X	X	1	> 1
ADC12	Channel 12, A12	1	X	0	X
LCD	Segment S0, initial state	0	≥ 01h	0	X
Port	P5.1	0	< 01h	0	X

PnSEL.x	PnDIR.x	Direction Control From Module	PnOUT.x	Module X OUT	PnIN.x	Module X IN	Segment	Port/LCD
P5SEL.1	P5DIR.1	P5DIR.1	P5OUT.1	DVSS	P5IN.1	Unused	S0	0: LCDPx < 01h

### 9.10.13 Port P5, P5.2 to P5.4, Input/Output With Schmitt Trigger

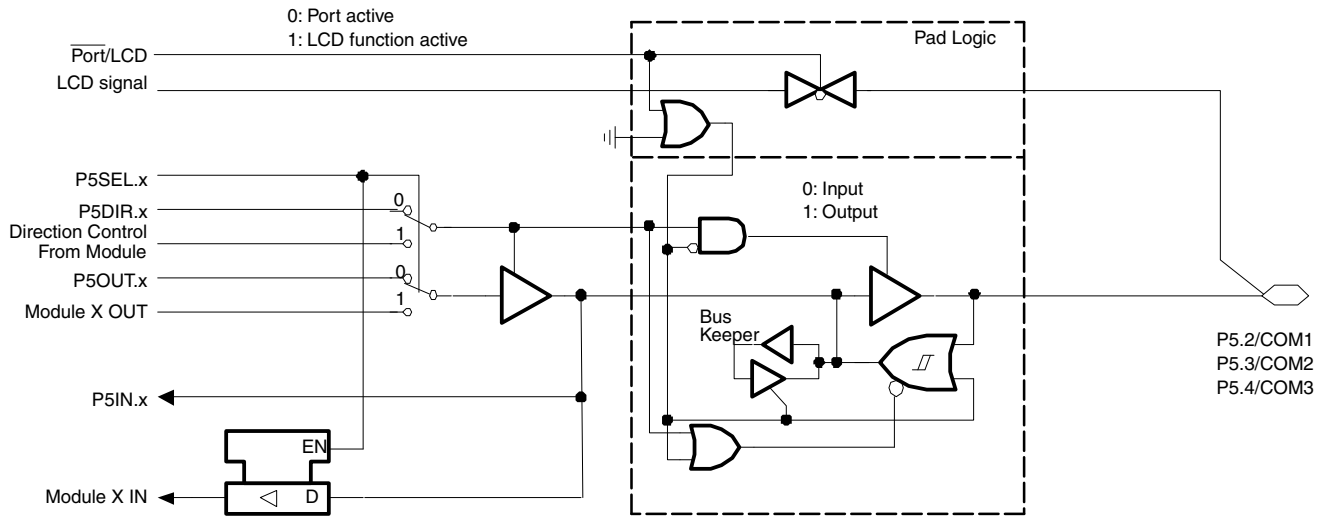

Note:  $2 \leq x \leq 4$

PnSel.x	PnDIR.x	Direction Control From Module	PnOUT.x	Module X OUT	PnIN.x	Module X IN	LCD signal	Port/LCD
P5Sel.2	P5DIR.2	P5DIR.2	P5OUT.2	DVSS	P5IN.2	Unused	COM1	P5SEL.2
P5Sel.3	P5DIR.3	P5DIR.3	P5OUT.3	DVSS	P5IN.3	Unused	COM2	P5SEL.3
P5Sel.4	P5DIR.4	P5DIR.4	P5OUT.4	DVSS	P5IN.4	Unused	COM3	P5SEL.4

### 9.10.14 Port P5, P5.5 to P5.7, Input/Output With Schmitt Trigger

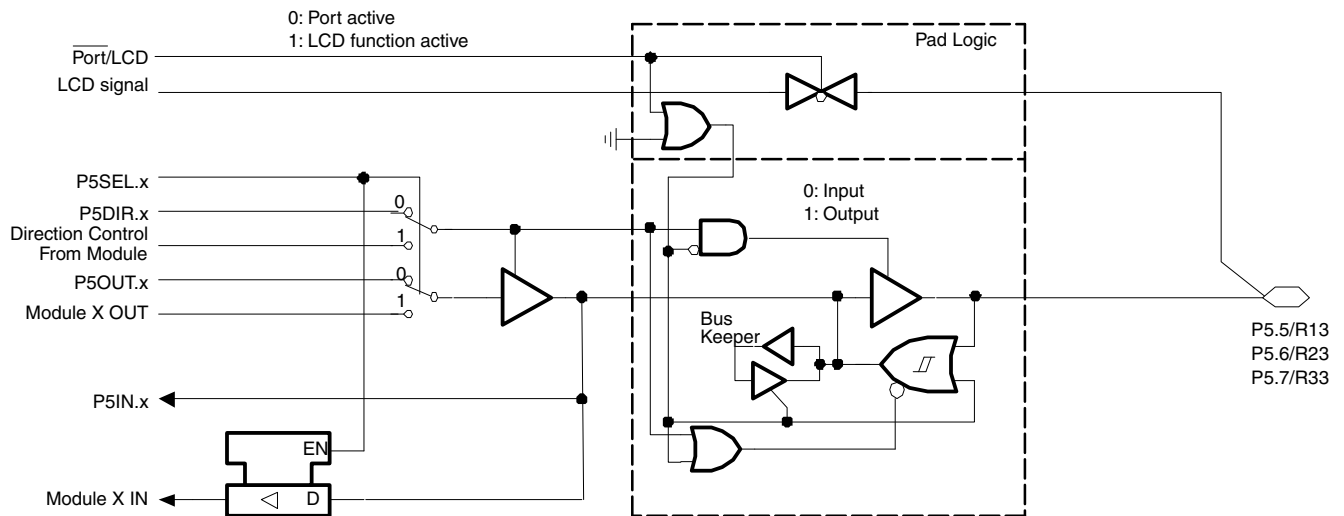

Note:  $5 \leq x \leq 7$

PnSel.x	PnDIR.x	Direction Control From Module	PnOUT.x	Module X OUT	PnIN.x	Module X IN	LCD signal	$\overline{\text{Port/LCD}}$
P5Sel.5	P5DIR.5	P5DIR.5	P5OUT.5	DVSS	P5IN.5	Unused	R13	P5SEL.5
P5Sel.6	P5DIR.6	P5DIR.6	P5OUT.6	DVSS	P5IN.6	Unused	R23	P5SEL.6
P5Sel.7	P5DIR.7	P5DIR.7	P5OUT.7	DVSS	P5IN.7	Unused	R33	P5SEL.7

### 9.10.15 Port P6, P6.0, P6.2, and P6.4, Input/Output With Schmitt Trigger

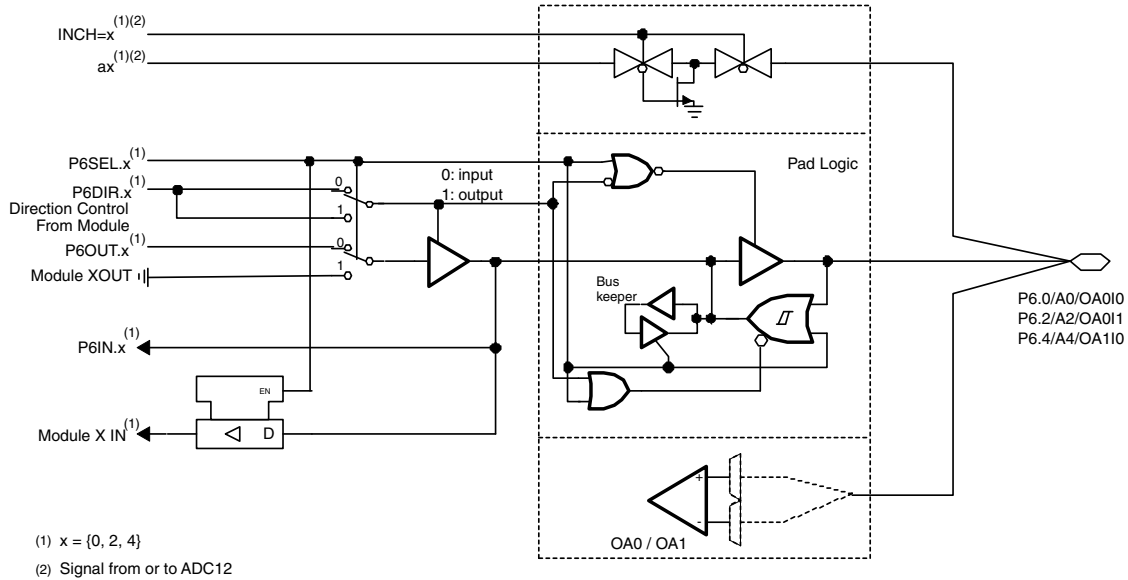

PnSel.x <sup>(1)</sup>	PnDIR.x	Direction Control From Module	PnOUT.x	Module X OUT	PnIN.x	Module X IN
P6Sel.0	P6DIR.0	P6DIR.0	P6OUT.0	DVSS	P6IN.0	unused
P6Sel.2	P6DIR.2	P6DIR.2	P6OUT.2	DVSS	P6IN.2	unused
P6Sel.4	P6DIR.4	P6DIR.4	P6OUT.4	DVSS	P6IN.4	unused

(1) The signal at pin P6.x/Ax is used by the 12-bit ADC module.

### 9.10.16 Port P6, P6.1, Input/Output With Schmitt Trigger

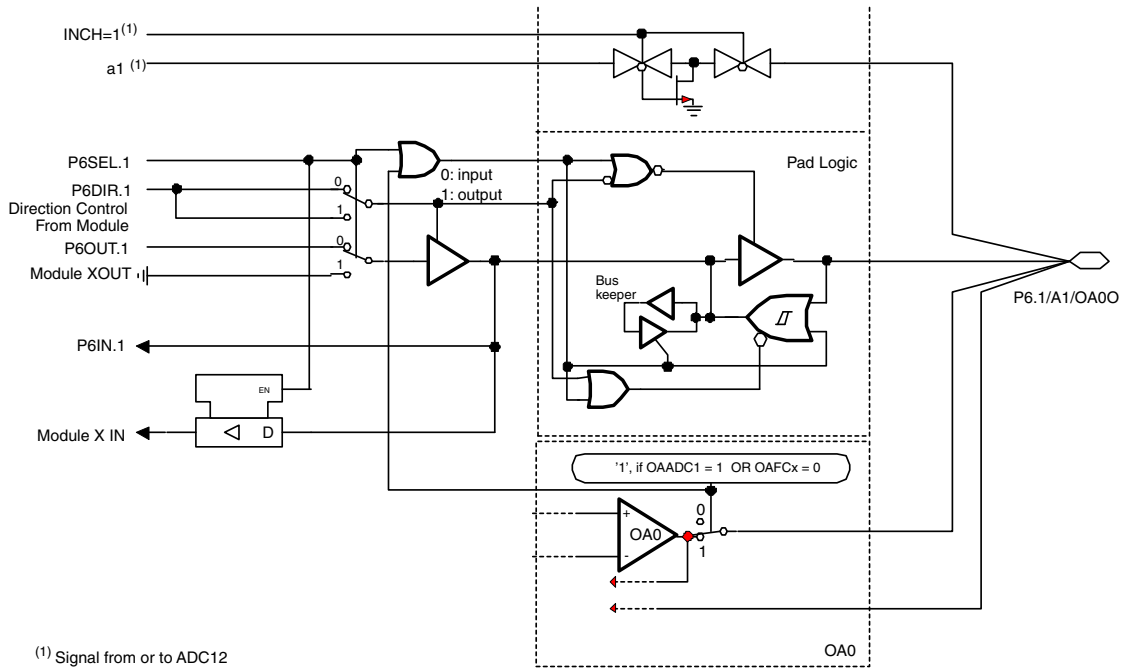

(1) Signal from or to ADC12

PnSel.x <sup>(1)</sup>	PnDIR.x	Direction Control From Module	PnOUT.x	Module X OUT	PnIN.x	Module X IN
P6Sel.1	P6DIR.1	P6DIR.1	P6OUT.1	DVSS	P6IN.1	unused

(1) The signal at pin P6.x/Ax is used by the 12-bit ADC module.

### 9.10.17 Port P6, P6.3, Input/Output With Schmitt Trigger

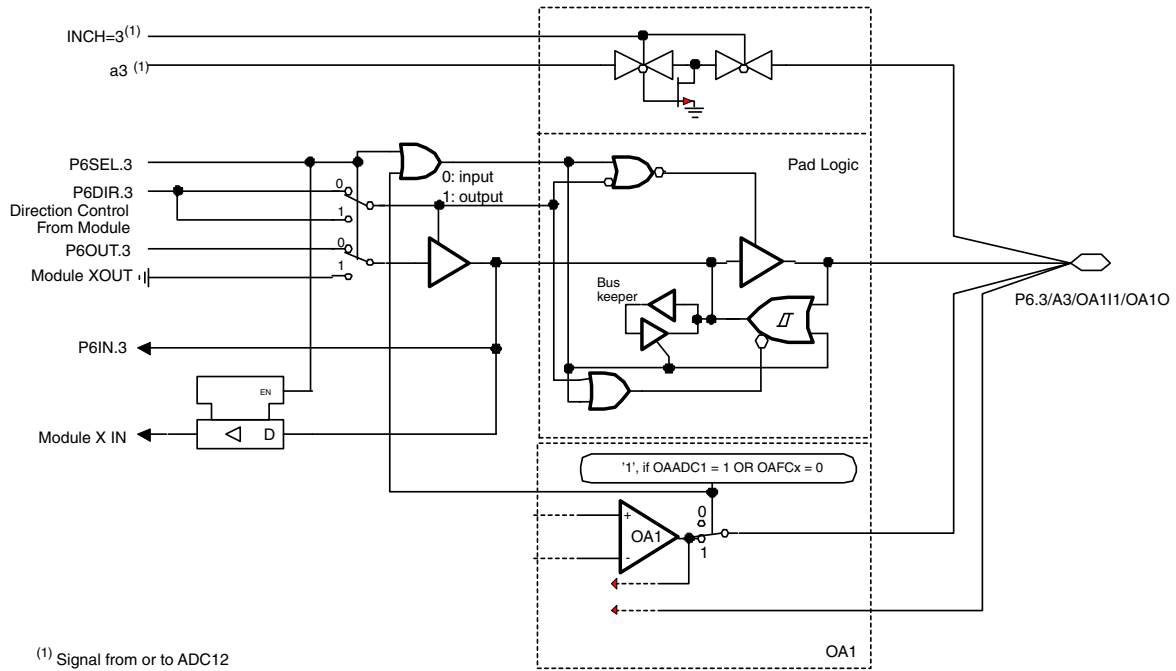

<sup>(1)</sup> Signal from or to ADC12

PnSel.x <sup>(1)</sup>	PnDIR.x	Direction Control From Module	PnOUT.x	Module X OUT	PnIN.x	Module X IN
P6Sel.3	P6DIR.3	P6DIR.3	P6OUT.3	DVSS	P6IN.3	unused

(1) The signal at pin P6.x/Ax is used by the 12-bit ADC module.

### 9.10.18 Port P6, P6.5, Input/Output With Schmitt Trigger

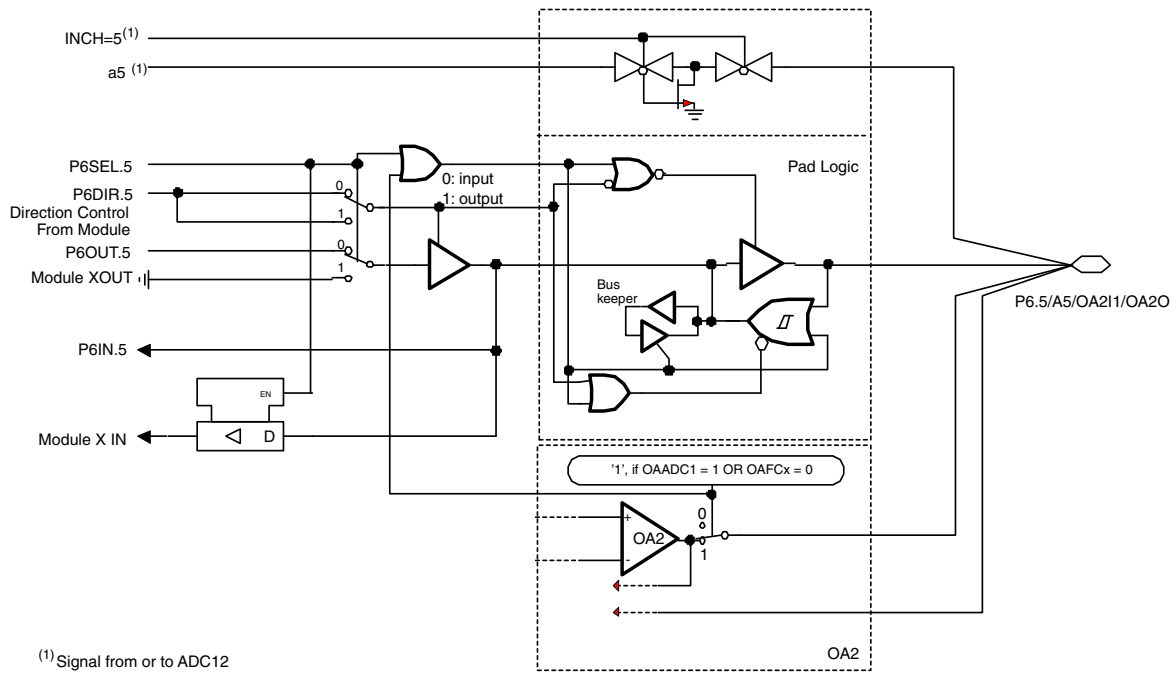

(1) Signal from or to ADC12

PnSel.x <sup>(1)</sup>	PnDIR.x	Direction Control From Module	PnOUT.x	Module X OUT	PnIN.x	Module X IN
P6Sel.5	P6DIR.5	P6DIR.5	P6OUT.5	DVSS	P6IN.5	unused

(1) The signal at pins P6.x/Ax is used by the 12-bit ADC module.

### 9.10.19 Port P6, P6.6, Input/Output With Schmitt Trigger

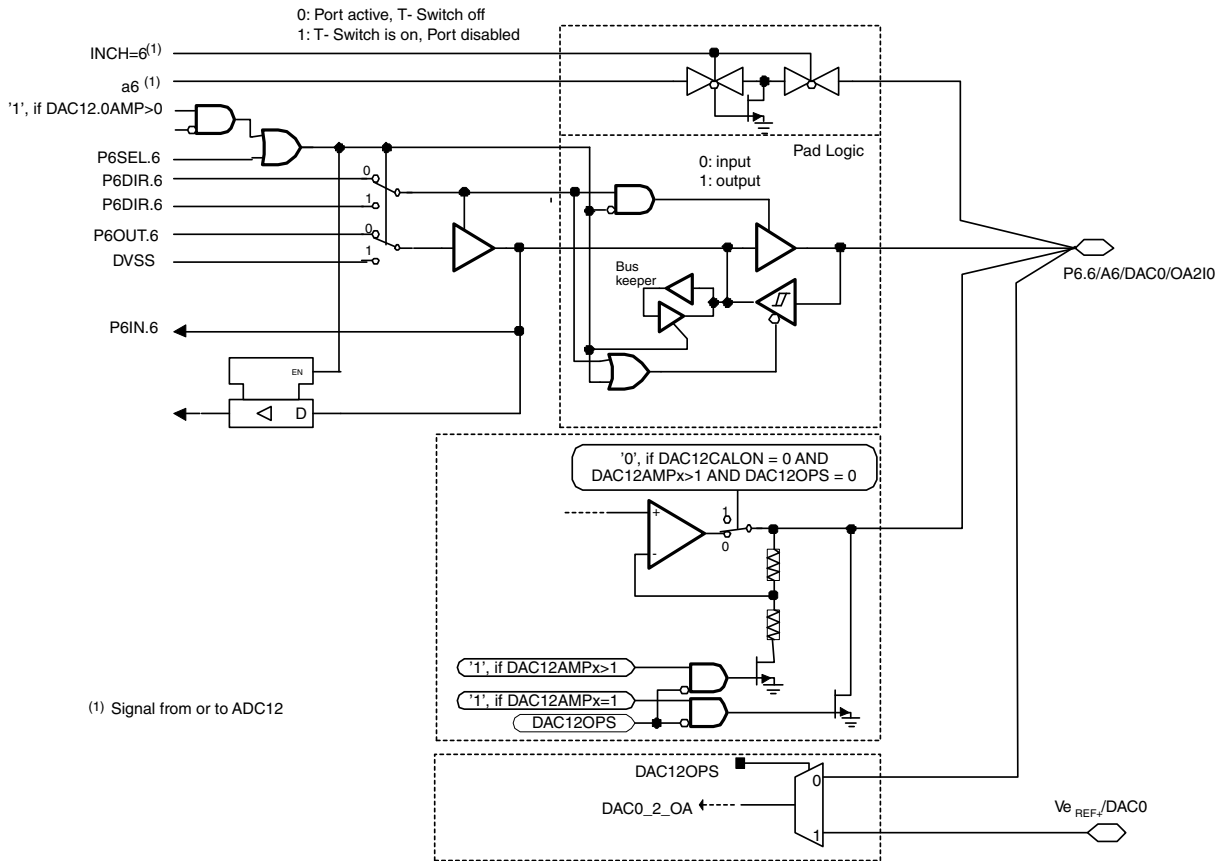

PnSel.x <sup>(1)</sup>	PnDIR.x	Direction Control From Module	PnOUT.x	Module X OUT	PnIN.x	Module X IN
P6Sel.6	P6DIR.6	P6DIR.6	P6OUT.6	DVSS	P6IN.6	unused

(1) The signal at pins P6.x/Ax is used by the 12-bit ADC module.

### 9.10.20 Port P6, P6.7, Input/Output With Schmitt Trigger

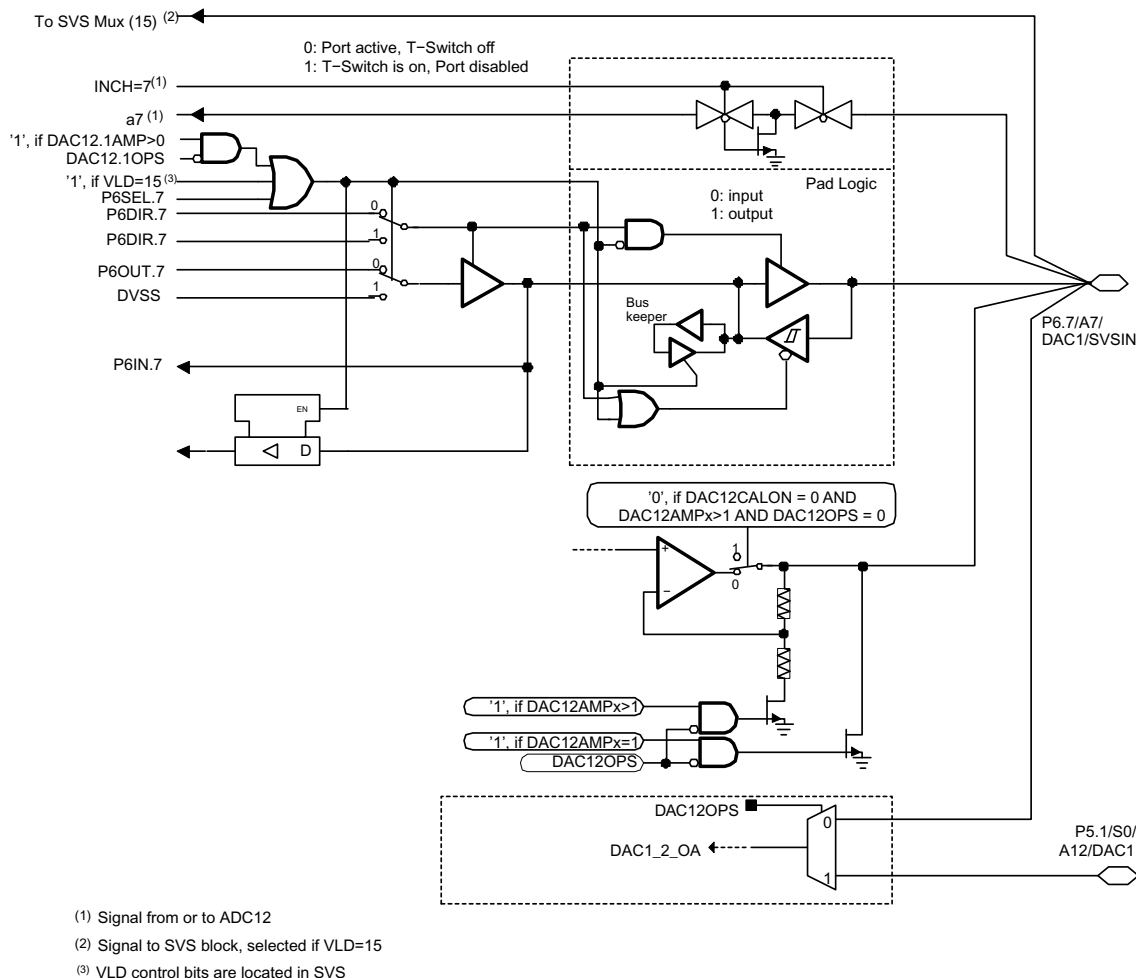

PnSel.x <sup>(1)</sup>	PnDIR.x	Direction Control From Module	PnOUT.x	Module X OUT	PnIN.x	Module X IN
P6Sel.7	P6DIR.7	P6DIR.7	P6OUT.7	DVSS	P6IN.7	unused

- (1) The signal at pins P6.x/Ax is used by the 12-bit ADC module. The signal at pin P6.7/A7/SVSIN is also connected to the input multiplexer in the module brownout/supply voltage supervisor.

**9.10.21 VeREF+/DAC0**

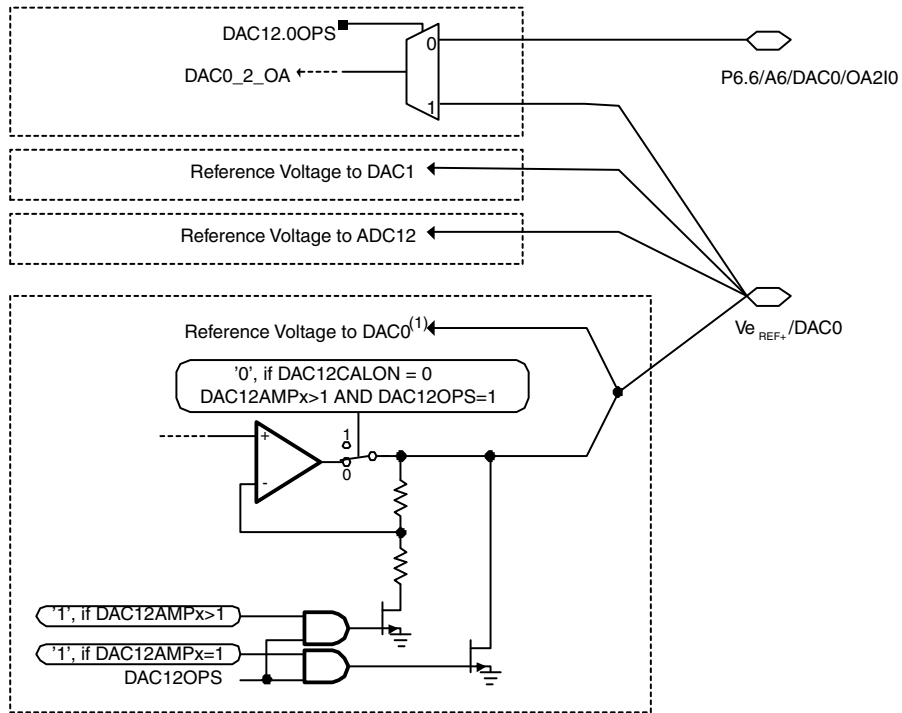

(1) If the reference of DAC0 is taken from pin  $V_{eREF+}/DAC0$ , unpredictable voltage levels will be on pin. In this situation, the DAC0 output is fed back to its own reference input.

### 9.10.22 JTAG Pins TMS, TCK, TDI/TCLK, TDO/TDI, Input/Output With Schmitt Trigger or Output

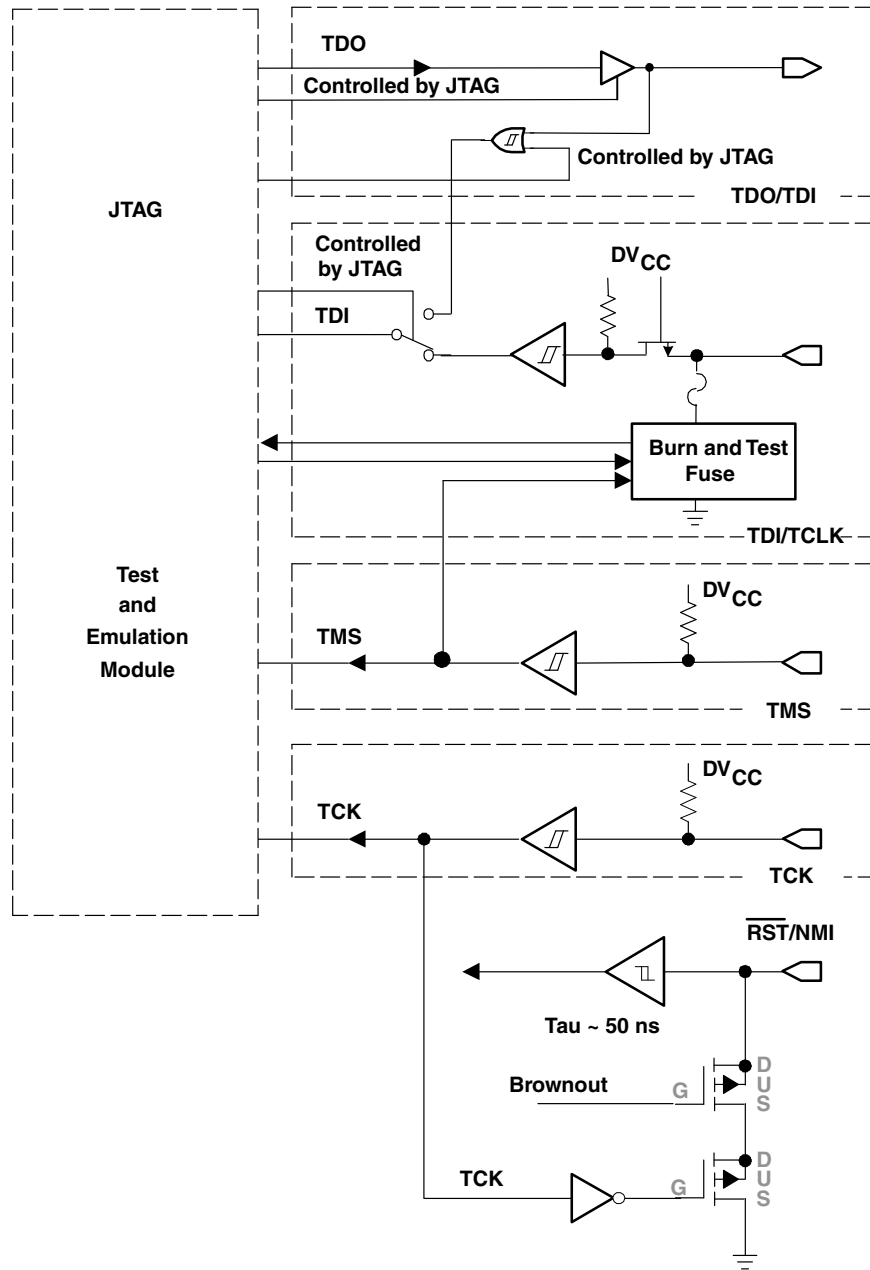

### 9.10.23 JTAG Fuse Check Mode

MSP430 devices that have the fuse on the TDI/TCLK terminal have a fuse check mode that tests the continuity of the fuse the first time the JTAG port is accessed after a power-on reset (POR). When activated, a fuse check current ( $I_{(TF)}$ ) of 1 mA at 3 V can flow from the TDI/TCLK pin to ground if the fuse is not burned. Care must be taken to avoid accidentally activating the fuse check mode and increasing overall system power consumption.

Activation of the fuse check mode occurs with the first negative edge on the TMS pin after power up or if the TMS is being held low during power up. The second positive edge on the TMS pin deactivates the fuse check mode. After deactivation, the fuse check mode remains inactive until another POR occurs. After each POR the fuse check mode has the potential to be activated.

The fuse check current only flows when the fuse check mode is active and the TMS pin is in a low state (see Figure 9-8). Therefore, the additional current flow can be prevented by holding the TMS pin high (default condition). The JTAG pins are terminated internally and therefore do not require external termination.

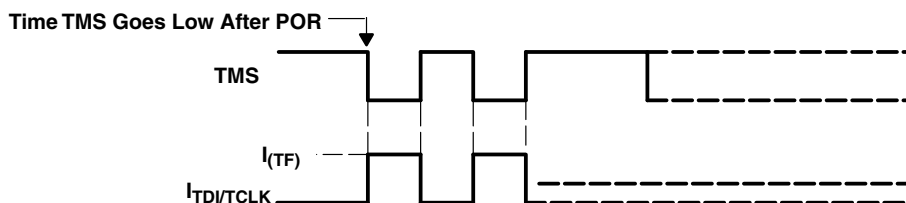

**Figure 9-8. Fuse Check Mode Current**

## 10 Device and Documentation Support

### 10.1 Device Support

#### 10.1.1 Development Support

TI offers an extensive line of development tools, including tools to evaluate the performance of the processors, generate code, develop algorithm implementations, and fully integrate and debug software and hardware modules. The tool's support documentation is electronically available within the Code Composer Studio™ Integrated Development Environment (IDE).

The following products support development of the MSP430FG43x device applications:

**Software Development Tools:** Code Composer Studio™ Integrated Development Environment (IDE): including Editor C/C++/Assembly Code Generation, and Debug plus additional development tools.

For a complete listing of development-support tools for the MSP430FG43x platform, visit the Texas Instruments website at [www.ti.com](http://www.ti.com). For information on pricing and availability, contact the nearest TI field sales office or authorized distributor.

##### 10.1.1.1 Development Kit

The [MSP-FET430U80](#) is a powerful flash emulation tool that includes the hardware and software required to quickly begin application development on the MSP430 MCU. It includes a ZIF socket target board and a USB debugging interface (MSP-FET) used to program and debug the MSP430 in-system through the JTAG interface or the pin saving Spy Bi-Wire (2-wire JTAG) protocol. The flash memory can be erased and programmed in seconds with only a few keystrokes, and because the MSP430 flash is ultra-low power, no external power supply is required.

The debugging tool interfaces the MSP430 to the included integrated software environment and includes code to start your design immediately.

#### 10.1.2 Device Nomenclature

To designate the stages in the product development cycle, TI assigns prefixes to the part numbers of all MSP MCU devices. Each MSP MCU commercial family member has one of two prefixes: MSP or XMS. These prefixes represent evolutionary stages of product development from engineering prototypes (XMS) through fully qualified production devices (MSP).

**XMS** – Experimental device that is not necessarily representative of the final device's electrical specifications

**MSP** – Fully qualified production device

XMS devices are shipped against the following disclaimer:

"Developmental product is intended for internal evaluation purposes."

MSP devices have been characterized fully, and the quality and reliability of the device have been demonstrated fully. TI's standard warranty applies.

Predictions show that prototype devices (XMS) have a greater failure rate than the standard production devices. TI recommends that these devices not be used in any production system because their expected end-use failure rate still is undefined. Only qualified production devices are to be used.

TI device nomenclature also includes a suffix with the device family name. This suffix indicates the temperature range, package type, and distribution format. [Figure 10-1](#) provides a legend for reading the complete device name.

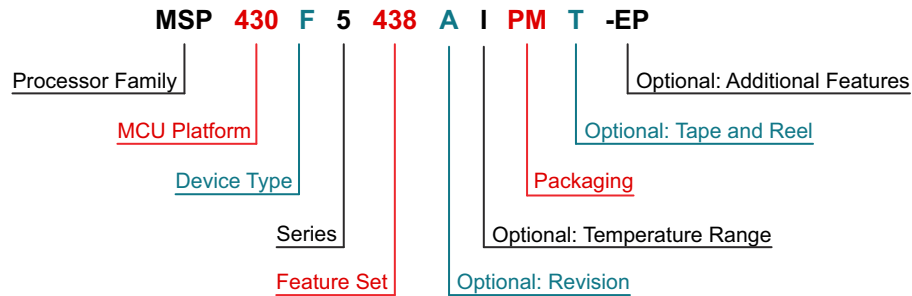

<b>Processor Family</b>	CC = Embedded RF Radio MSP = Mixed-Signal Processor XMS = Experimental Silicon PMS = Prototype Device		
<b>MCU Platform</b>	430 = MSP430 low-power microcontroller platform		
<b>Device Type</b>	<table border="0" style="width: 100%;"> <tr> <td style="vertical-align: top;"><b>Memory Type</b> C = ROM F = Flash FR = FRAM G = Flash L = No nonvolatile memory</td> <td style="vertical-align: top;"><b>Specialized Application</b> AFE = Analog front end BQ = Contactless power CG = ROM medical FE = Flash energy meter FG = Flash medical FW = Flash electronic flow meter</td> </tr> </table>	<b>Memory Type</b> C = ROM F = Flash FR = FRAM G = Flash L = No nonvolatile memory	<b>Specialized Application</b> AFE = Analog front end BQ = Contactless power CG = ROM medical FE = Flash energy meter FG = Flash medical FW = Flash electronic flow meter
<b>Memory Type</b> C = ROM F = Flash FR = FRAM G = Flash L = No nonvolatile memory	<b>Specialized Application</b> AFE = Analog front end BQ = Contactless power CG = ROM medical FE = Flash energy meter FG = Flash medical FW = Flash electronic flow meter		
<b>Series</b>	<table border="0" style="width: 100%;"> <tr> <td style="vertical-align: top;">1 = Up to 8 MHz 2 = Up to 16 MHz 3 = Legacy 4 = Up to 16 MHz with LCD driver</td> <td style="vertical-align: top;">5 = Up to 25 MHz 6 = Up to 25 MHz with LCD driver 0 = Low-voltage series</td> </tr> </table>	1 = Up to 8 MHz 2 = Up to 16 MHz 3 = Legacy 4 = Up to 16 MHz with LCD driver	5 = Up to 25 MHz 6 = Up to 25 MHz with LCD driver 0 = Low-voltage series
1 = Up to 8 MHz 2 = Up to 16 MHz 3 = Legacy 4 = Up to 16 MHz with LCD driver	5 = Up to 25 MHz 6 = Up to 25 MHz with LCD driver 0 = Low-voltage series		
<b>Feature Set</b>	Various levels of integration within a series		
<b>Optional: Revision</b>	Updated version of the base part number		
<b>Optional: Temperature Range</b>	S = 0°C to 50°C C = 0°C to 70°C I = -40°C to 85°C T = -40°C to 105°C		
<b>Packaging</b>	<a href="http://www.ti.com/packaging">http://www.ti.com/packaging</a>		
<b>Optional: Tape and Reel</b>	T = Small reel R = Large reel No markings = Tube or tray		
<b>Optional: Additional Features</b>	-EP = Enhanced product (-40°C to 105°C) -HT = Extreme temperature parts (-55°C to 150°C) -Q1 = Automotive Q100 qualified		

**Figure 10-1. Device Nomenclature**

## 10.2 Documentation Support

The following documents describe the MSP430FG43x microcontrollers. Copies of these documents are available on the Internet at [www.ti.com](http://www.ti.com).

### [MSP430x4xx Family User's Guide](#)

Detailed description of all modules and peripherals available in this device family.

### [MSP430FG439 Microcontroller Errata](#)

Describes the known exceptions to the functional specifications for all silicon revisions of this device.

### [MSP430FG438 Microcontroller Errata](#)

Describes the known exceptions to the functional specifications for all silicon revisions of this device.

### [MSP430FG437 Microcontroller Errata](#)

Describes the known exceptions to the functional specifications for all silicon revisions of this device.

## 10.3 Support Resources

[TI E2E™ support forums](#) are an engineer's go-to source for fast, verified answers and design help — straight from the experts. Search existing answers or ask your own question to get the quick design help you need.

[MSP Academy](#) is a starting point for all developers to learn about the MSP430 MCU Platform, which provides affordable solutions for many applications. MSP Academy delivers easy-to-use training modules that span a wide range of topics and LaunchPad development kits in the MSP430 MCU portfolio.

Linked content is provided "AS IS" by the respective contributors. They do not constitute TI specifications and do not necessarily reflect TI's views; see TI's [Terms of Use](#).

## 10.4 Trademarks

MSP430™ and TI E2E™ are trademarks of Texas Instruments.  
All trademarks are the property of their respective owners.

## 10.5 Electrostatic Discharge Caution



This integrated circuit can be damaged by ESD. Texas Instruments recommends that all integrated circuits be handled with appropriate precautions. Failure to observe proper handling and installation procedures can cause damage.

ESD damage can range from subtle performance degradation to complete device failure. Precision integrated circuits may be more susceptible to damage because very small parametric changes could cause the device not to meet its published specifications.

## 10.6 Glossary

[TI Glossary](#) This glossary lists and explains terms, acronyms, and definitions.

## **11 Mechanical Packaging and Orderable Information**

### **11.1 Packaging Information**

The following pages include mechanical packaging and orderable information. This information is the most current data available for the designated devices. This data is subject to change without notice and revision of this document. For browser-based versions of this data sheet, refer to the left-hand navigation.

**PACKAGING INFORMATION**

Orderable Device	Status (1)	Package Type	Package Drawing	Pins	Package Qty	Eco Plan (2)	Lead finish/ Ball material (6)	MSL Peak Temp (3)	Op Temp (°C)	Device Marking (4/5)	Samples
MSP430FG437IPN	ACTIVE	LQFP	PN	80	119	RoHS & Green	NIPDAU	Level-3-260C-168 HR	-40 to 85	M430FG437	<a href="#">Samples</a>
MSP430FG437IPNR	ACTIVE	LQFP	PN	80	1000	RoHS & Green	NIPDAU	Level-3-260C-168 HR	-40 to 85	M430FG437	<a href="#">Samples</a>
MSP430FG437IZCAR	ACTIVE	NFBGA	ZCA	113	2500	RoHS & Green	SNAGCU	Level-3-260C-168 HR	-40 to 85	FG437	<a href="#">Samples</a>
MSP430FG437IZCAT	ACTIVE	NFBGA	ZCA	113	250	RoHS & Green	SNAGCU	Level-3-260C-168 HR	-40 to 85	FG437	<a href="#">Samples</a>
MSP430FG438IPN	ACTIVE	LQFP	PN	80	119	RoHS & Green	NIPDAU	Level-3-260C-168 HR	-40 to 85	M430FG438	<a href="#">Samples</a>
MSP430FG438IPNR	ACTIVE	LQFP	PN	80	1000	RoHS & Green	NIPDAU	Level-3-260C-168 HR	-40 to 85	M430FG438	<a href="#">Samples</a>
MSP430FG438IZCAR	ACTIVE	NFBGA	ZCA	113	2500	RoHS & Green	SNAGCU	Level-3-260C-168 HR	-40 to 85	FG438	<a href="#">Samples</a>
MSP430FG438IZCAT	ACTIVE	NFBGA	ZCA	113	250	RoHS & Green	SNAGCU	Level-3-260C-168 HR	-40 to 85	FG438	<a href="#">Samples</a>
MSP430FG439IPN	ACTIVE	LQFP	PN	80	119	RoHS & Green	NIPDAU	Level-3-260C-168 HR	-40 to 85	M430FG439	<a href="#">Samples</a>
MSP430FG439IPNR	ACTIVE	LQFP	PN	80	1000	RoHS & Green	NIPDAU	Level-3-260C-168 HR	-40 to 85	M430FG439	<a href="#">Samples</a>
MSP430FG439IZCAR	ACTIVE	NFBGA	ZCA	113	2500	RoHS & Green	SNAGCU	Level-3-260C-168 HR	-40 to 85	FG439	<a href="#">Samples</a>
MSP430FG439IZCAT	ACTIVE	NFBGA	ZCA	113	250	RoHS & Green	SNAGCU	Level-3-260C-168 HR	-40 to 85	FG439	<a href="#">Samples</a>

(1) The marketing status values are defined as follows:

**ACTIVE:** Product device recommended for new designs.

**LIFEBUY:** TI has announced that the device will be discontinued, and a lifetime-buy period is in effect.

**NRND:** Not recommended for new designs. Device is in production to support existing customers, but TI does not recommend using this part in a new design.

**PREVIEW:** Device has been announced but is not in production. Samples may or may not be available.

**OBSELETE:** TI has discontinued the production of the device.

(2) **RoHS:** TI defines "RoHS" to mean semiconductor products that are compliant with the current EU RoHS requirements for all 10 RoHS substances, including the requirement that RoHS substance do not exceed 0.1% by weight in homogeneous materials. Where designed to be soldered at high temperatures, "RoHS" products are suitable for use in specified lead-free processes. TI may reference these types of products as "Pb-Free".

**RoHS Exempt:** TI defines "RoHS Exempt" to mean products that contain lead but are compliant with EU RoHS pursuant to a specific EU RoHS exemption.

**Green:** TI defines "Green" to mean the content of Chlorine (Cl) and Bromine (Br) based flame retardants meet JS709B low halogen requirements of <=1000ppm threshold. Antimony trioxide based flame retardants must also meet the <=1000ppm threshold requirement.

- (3) MSL, Peak Temp. - The Moisture Sensitivity Level rating according to the JEDEC industry standard classifications, and peak solder temperature.
- (4) There may be additional marking, which relates to the logo, the lot trace code information, or the environmental category on the device.
- (5) Multiple Device Markings will be inside parentheses. Only one Device Marking contained in parentheses and separated by a "-" will appear on a device. If a line is indented then it is a continuation of the previous line and the two combined represent the entire Device Marking for that device.
- (6) Lead finish/Ball material - Orderable Devices may have multiple material finish options. Finish options are separated by a vertical ruled line. Lead finish/Ball material values may wrap to two lines if the finish value exceeds the maximum column width.

**Important Information and Disclaimer:**The information provided on this page represents TI's knowledge and belief as of the date that it is provided. TI bases its knowledge and belief on information provided by third parties, and makes no representation or warranty as to the accuracy of such information. Efforts are underway to better integrate information from third parties. TI has taken and continues to take reasonable steps to provide representative and accurate information but may not have conducted destructive testing or chemical analysis on incoming materials and chemicals. TI and TI suppliers consider certain information to be proprietary, and thus CAS numbers and other limited information may not be available for release.

In no event shall TI's liability arising out of such information exceed the total purchase price of the TI part(s) at issue in this document sold by TI to Customer on an annual basis.

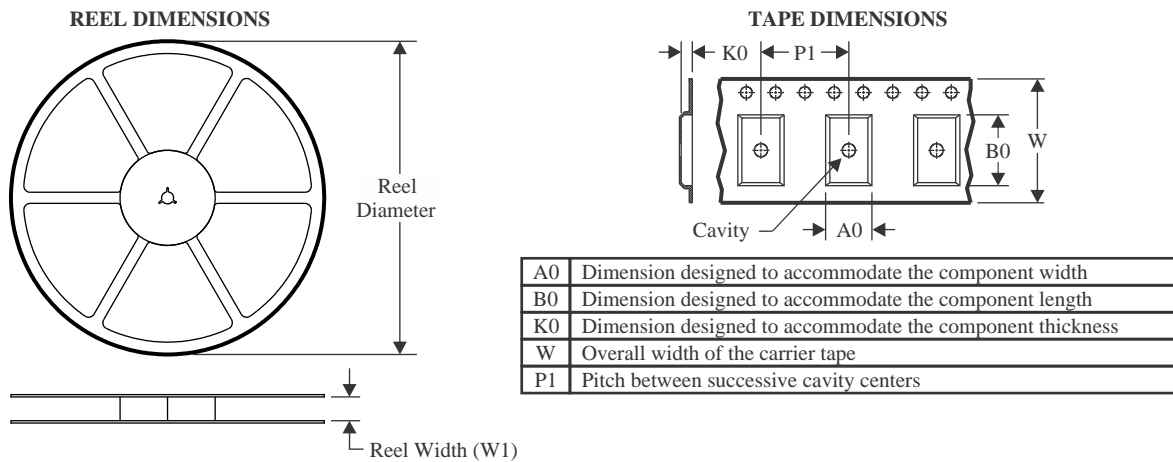
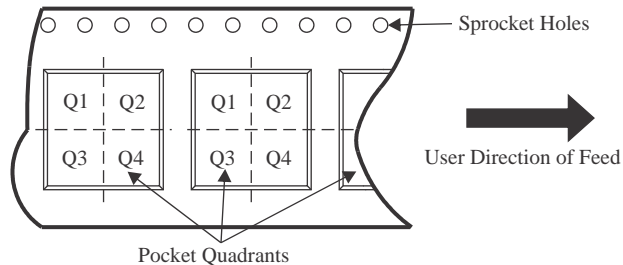
**TAPE AND REEL INFORMATION**

**QUADRANT ASSIGNMENTS FOR PIN 1 ORIENTATION IN TAPE**

\*All dimensions are nominal

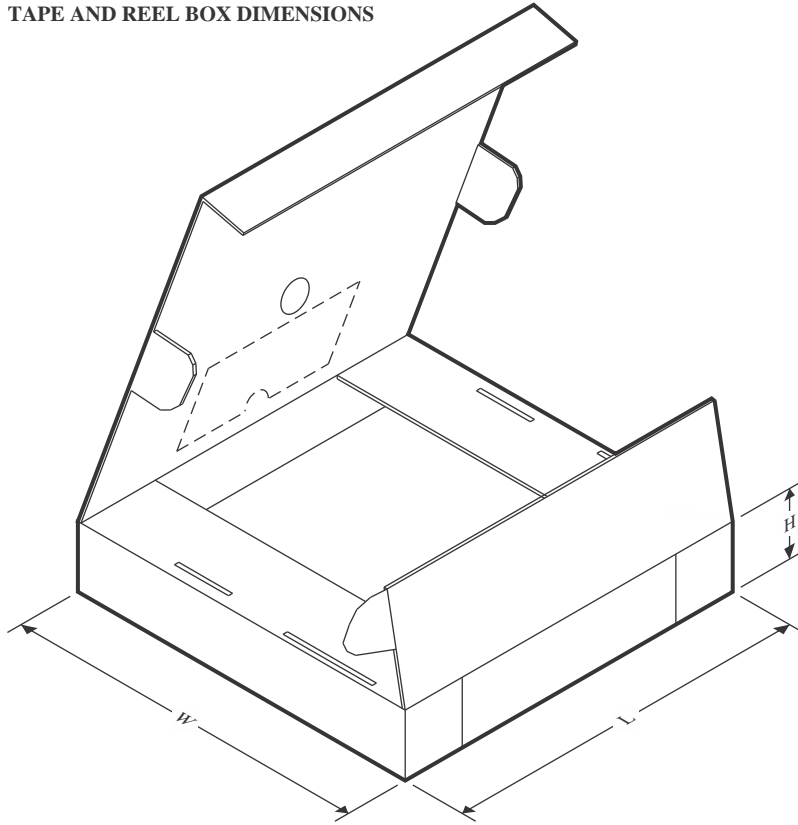
Device	Package Type	Package Drawing	Pins	SPQ	Reel Diameter (mm)	Reel Width W1 (mm)	A0 (mm)	B0 (mm)	K0 (mm)	P1 (mm)	W (mm)	Pin1 Quadrant
MSP430FG437IPNR	LQFP	PN	80	1000	330.0	24.4	15.0	15.0	2.1	20.0	24.0	Q2
MSP430FG437IZCAT	NFBGA	ZCA	113	250	330.0	16.4	7.3	7.3	1.5	12.0	16.0	Q1
MSP430FG438IPNR	LQFP	PN	80	1000	330.0	24.4	15.0	15.0	2.1	20.0	24.0	Q2
MSP430FG438IZCAR	NFBGA	ZCA	113	2500	330.0	16.4	7.3	7.3	1.5	12.0	16.0	Q1
MSP430FG438IZCAT	NFBGA	ZCA	113	250	330.0	16.4	7.3	7.3	1.5	12.0	16.0	Q1
MSP430FG439IPNR	LQFP	PN	80	1000	330.0	24.4	15.0	15.0	2.1	20.0	24.0	Q2
MSP430FG439IZCAT	NFBGA	ZCA	113	250	330.0	16.4	7.3	7.3	1.5	12.0	16.0	Q1

**TAPE AND REEL BOX DIMENSIONS**

\*All dimensions are nominal

Device	Package Type	Package Drawing	Pins	SPQ	Length (mm)	Width (mm)	Height (mm)
MSP430FG437IPNR	LQFP	PN	80	1000	367.0	367.0	45.0
MSP430FG437IZCAT	NFBGA	ZCA	113	250	341.0	336.6	31.8
MSP430FG438IPNR	LQFP	PN	80	1000	367.0	367.0	45.0
MSP430FG438IZCAR	NFBGA	ZCA	113	2500	341.0	336.6	31.8
MSP430FG438IZCAT	NFBGA	ZCA	113	250	341.0	336.6	31.8
MSP430FG439IPNR	LQFP	PN	80	1000	367.0	367.0	45.0
MSP430FG439IZCAT	NFBGA	ZCA	113	250	341.0	336.6	31.8

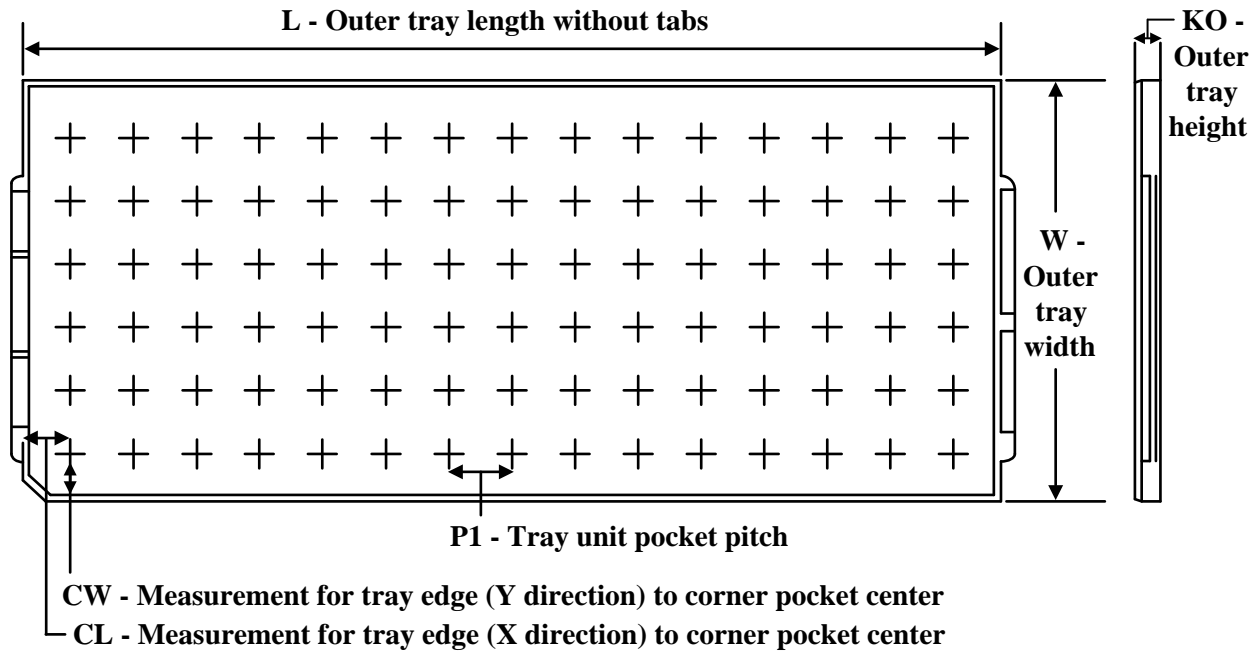
**TRAY**

Chamfer on Tray corner indicates Pin 1 orientation of packed units.

\*All dimensions are nominal

Device	Package Name	Package Type	Pins	SPQ	Unit array matrix	Max temperature (°C)	L (mm)	W (mm)	K0 (µm)	P1 (mm)	CL (mm)	CW (mm)
MSP430FG437IPN	PN	LQFP	80	119	7x17	180	315	135.9	7620	17.9	14.3	13.95
MSP430FG437IZCAR	ZCA	NFBGA	113	2500	10 x 26	150	315	135.9	7620	11.8	10	10.35
MSP430FG437IZCAT	ZCA	NFBGA	113	250	10 x 26	150	315	135.9	7620	11.8	10	10.35
MSP430FG438IPN	PN	LQFP	80	119	7x17	180	315	135.9	7620	17.9	14.3	13.95
MSP430FG438IZCAR	ZCA	NFBGA	113	2500	10 x 26	150	315	135.9	7620	11.8	10	10.35
MSP430FG438IZCAT	ZCA	NFBGA	113	250	10 x 26	150	315	135.9	7620	11.8	10	10.35
MSP430FG439IPN	PN	LQFP	80	119	7x17	180	315	135.9	7620	17.9	14.3	13.95
MSP430FG439IZCAR	ZCA	NFBGA	113	2500	10 x 26	150	315	135.9	7620	11.8	10	10.35
MSP430FG439IZCAT	ZCA	NFBGA	113	250	10 x 26	150	315	135.9	7620	11.8	10	10.35

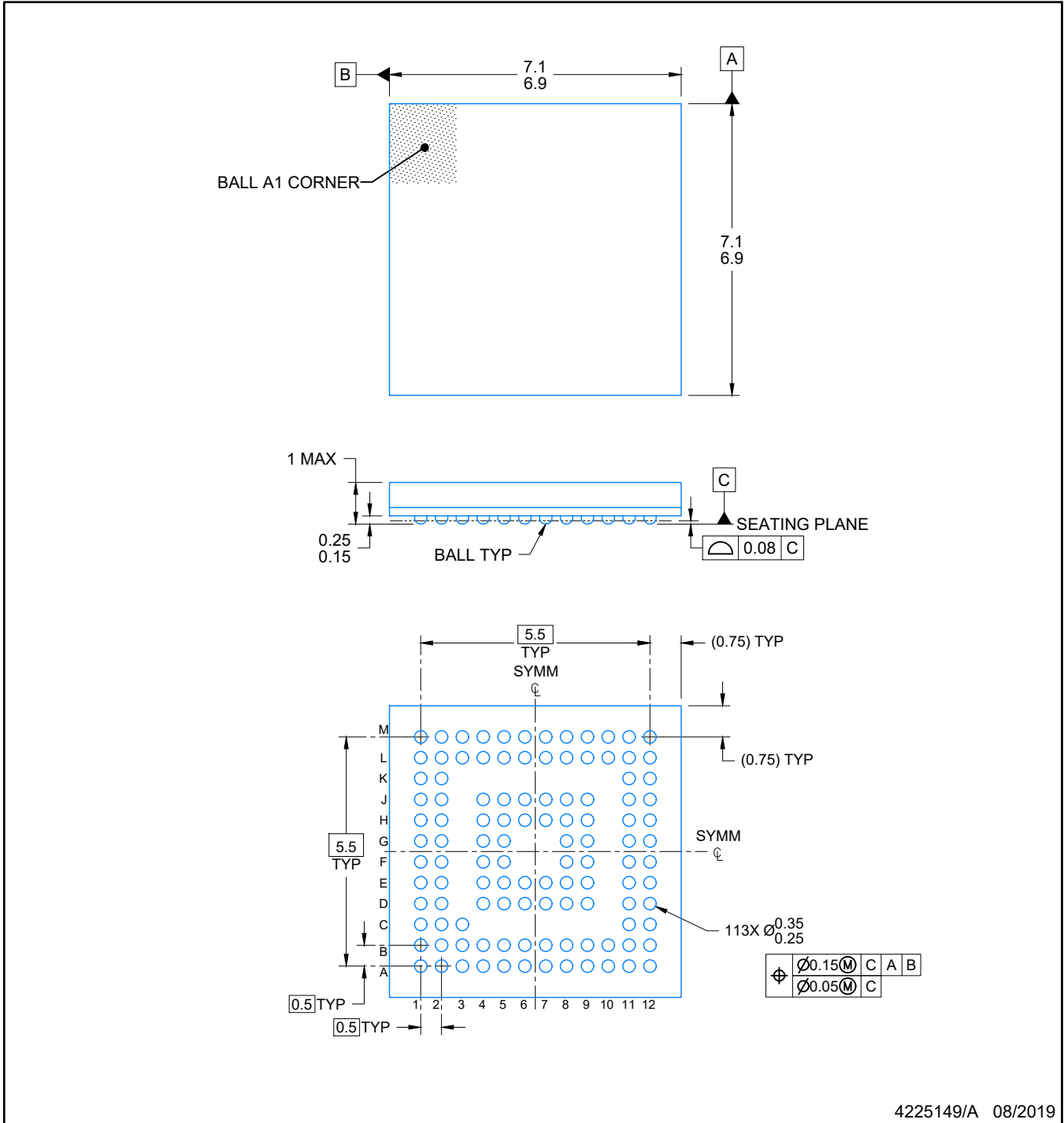

4225149/A 08/2019

NOTES:

NanoFree is a trademark of Texas Instruments.

1. All linear dimensions are in millimeters. Any dimensions in parenthesis are for reference only. Dimensioning and tolerancing per ASME Y14.5M.
2. This drawing is subject to change without notice.

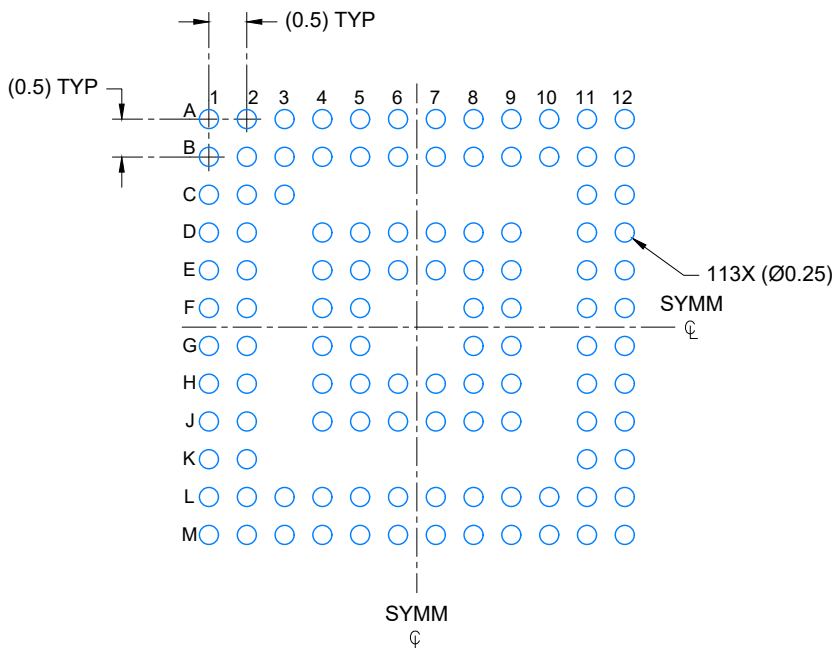

LAND PATTERN EXAMPLE  
SCALE: 10X

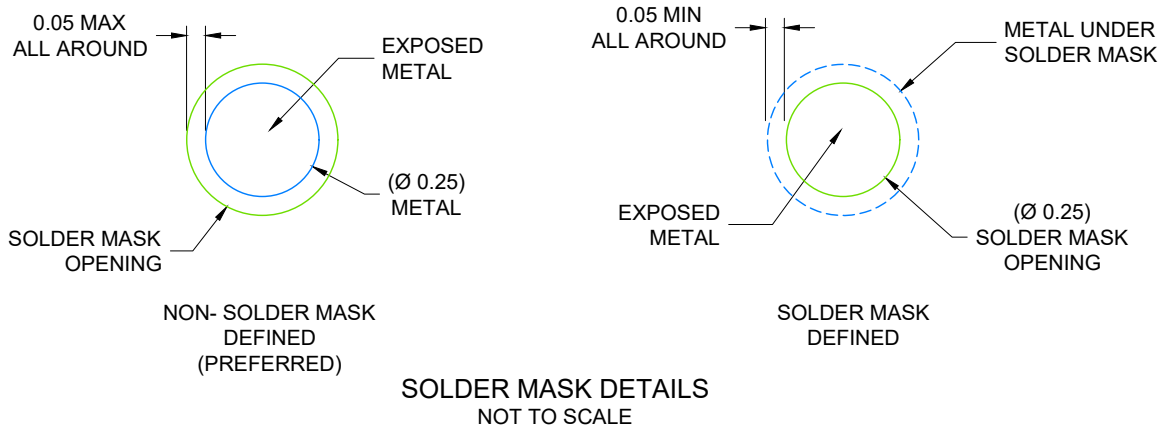

4225149/A 08/2019

NOTES: (continued)

- Final dimensions may vary due to manufacturing tolerance considerations and also routing constraints. Refer to Texas Instruments Literature number SNVA009 ([www.ti.com/lit/snva009](http://www.ti.com/lit/snva009)).

# EXAMPLE STENCIL DESIGN

ZCA0113A

NFBGA - 1 mm max height

PLASTIC BALL GRID ARRAY

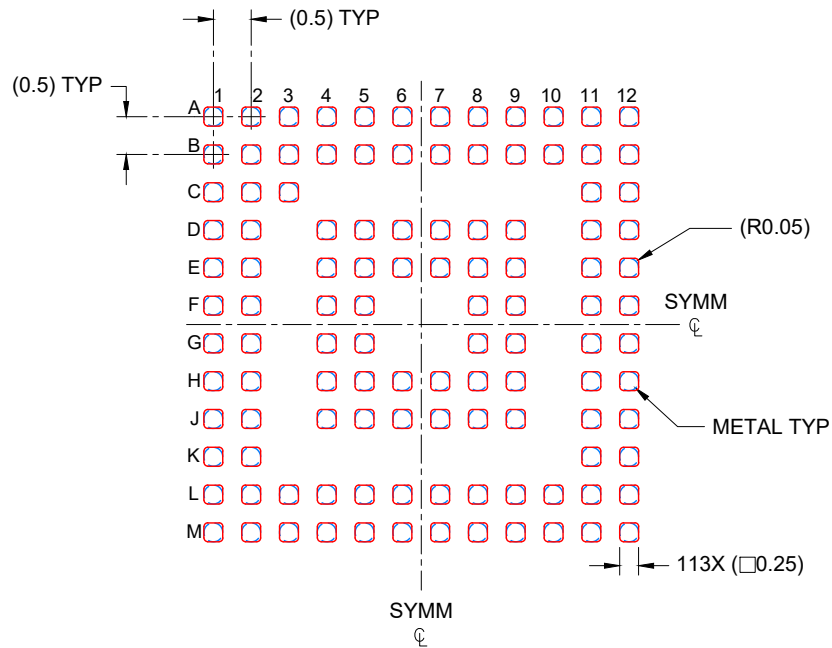

SOLDER PASTE EXAMPLE  
BASED ON 0.100 mm THICK STENCIL  
SCALE: 10X

4225149/A 08/2019

NOTES: (continued)

4. Laser cutting apertures with trapezoidal walls and rounded corners may offer better paste release.

# PN0080A

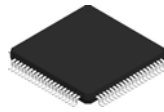

# PACKAGE OUTLINE

LQFP - 1.6 mm max height

PLASTIC QUAD FLATPACK

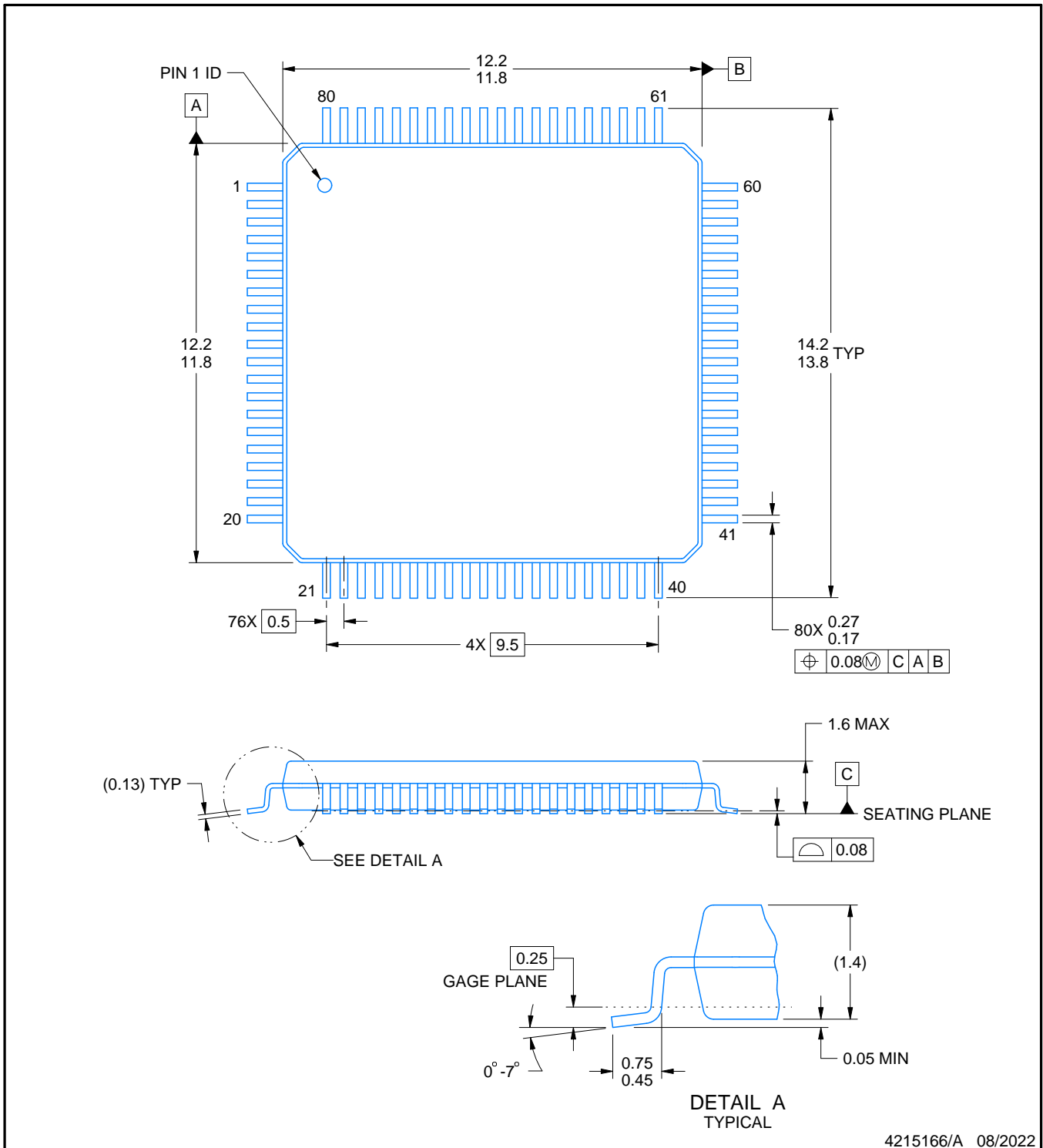

4215166/A 08/2022

**NOTES:**

1. All linear dimensions are in millimeters. Any dimensions in parenthesis are for reference only. Dimensioning and tolerancing per ASME Y14.5M.
2. This drawing is subject to change without notice.
3. Reference JEDEC registration MS-026.

# EXAMPLE BOARD LAYOUT

PN0080A

LQFP - 1.6 mm max height

PLASTIC QUAD FLATPACK

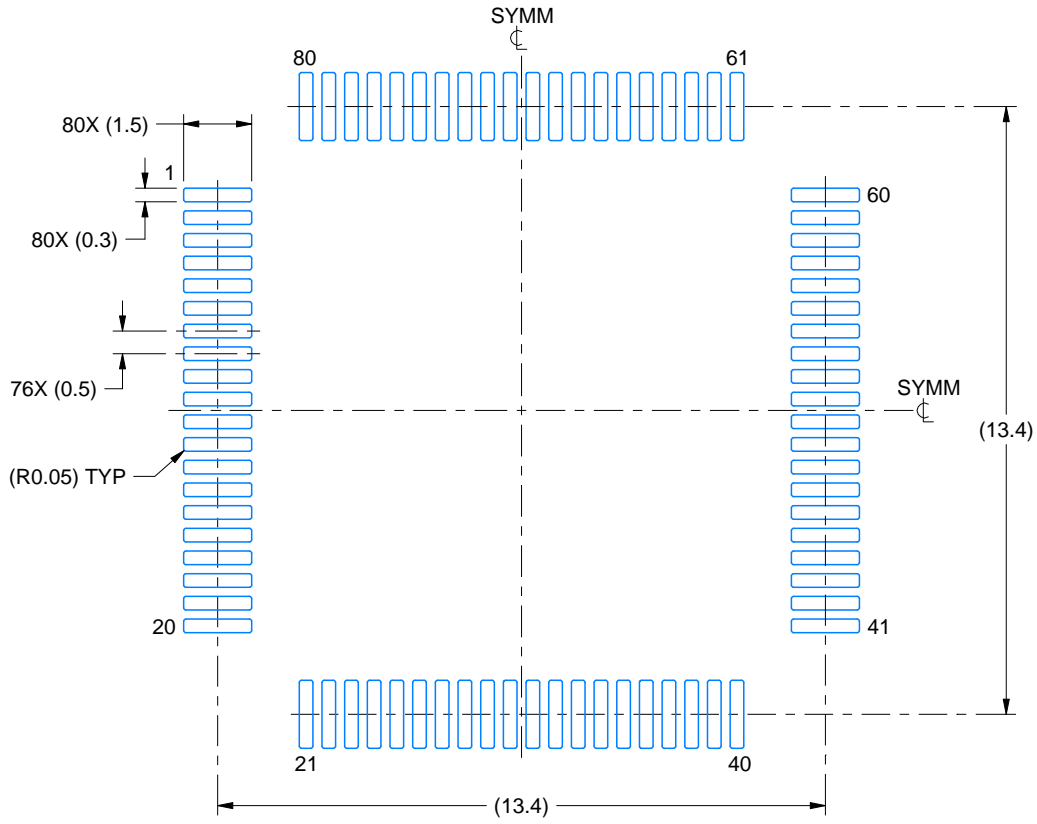

LAND PATTERN EXAMPLE  
EXPOSED METAL SHOWN  
SCALE:6X



SOLDER MASK DETAILS

4215166/A 08/2022

NOTES: (continued)

- 4. Publication IPC-7351 may have alternate designs.
- 5. Solder mask tolerances between and around signal pads can vary based on board fabrication site.
- 6. For more information, see Texas Instruments literature number SLMA004 ([www.ti.com/lit/slma004](http://www.ti.com/lit/slma004)).

# EXAMPLE STENCIL DESIGN

PN0080A

LQFP - 1.6 mm max height

PLASTIC QUAD FLATPACK

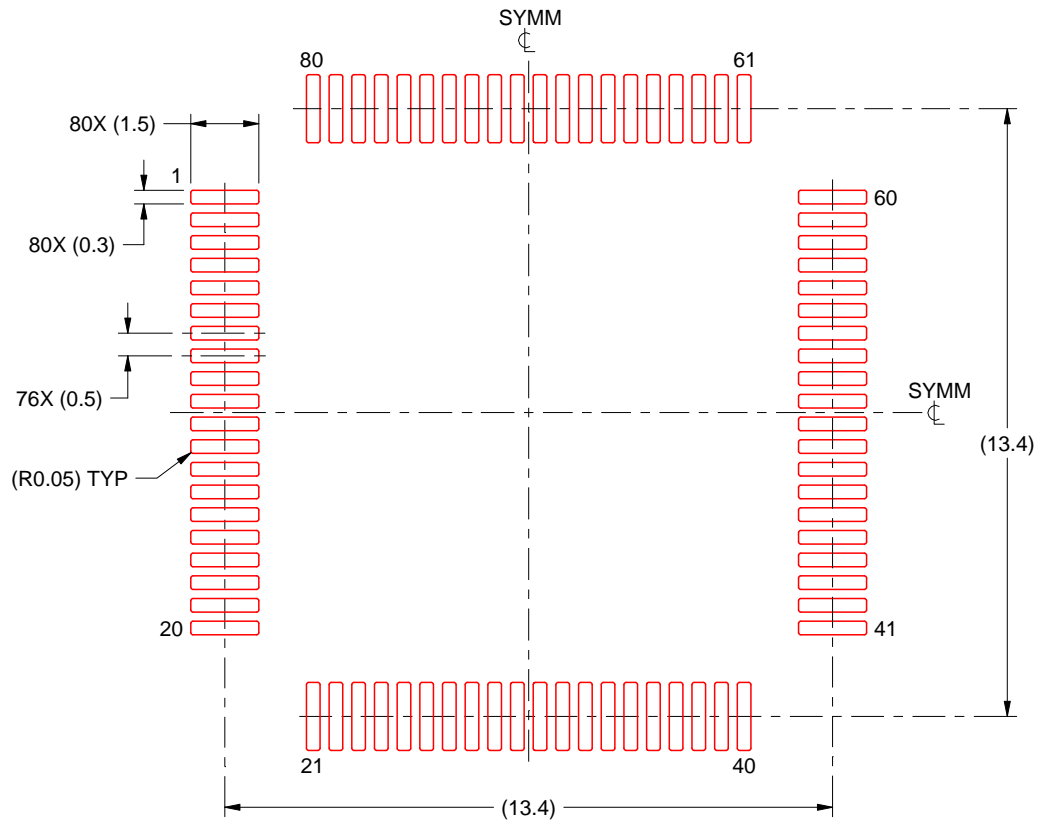

SOLDER PASTE EXAMPLE  
BASED ON 0.1 mm THICK STENCIL  
SCALE:6X

4215166/A 08/2022

NOTES: (continued)

7. Laser cutting apertures with trapezoidal walls and rounded corners may offer better paste release. IPC-7525 may have alternate design recommendations.
8. Board assembly site may have different recommendations for stencil design.

## IMPORTANT NOTICE AND DISCLAIMER

TI PROVIDES TECHNICAL AND RELIABILITY DATA (INCLUDING DATA SHEETS), DESIGN RESOURCES (INCLUDING REFERENCE DESIGNS), APPLICATION OR OTHER DESIGN ADVICE, WEB TOOLS, SAFETY INFORMATION, AND OTHER RESOURCES "AS IS" AND WITH ALL FAULTS, AND DISCLAIMS ALL WARRANTIES, EXPRESS AND IMPLIED, INCLUDING WITHOUT LIMITATION ANY IMPLIED WARRANTIES OF MERCHANTABILITY, FITNESS FOR A PARTICULAR PURPOSE OR NON-INFRINGEMENT OF THIRD PARTY INTELLECTUAL PROPERTY RIGHTS.

These resources are intended for skilled developers designing with TI products. You are solely responsible for (1) selecting the appropriate TI products for your application, (2) designing, validating and testing your application, and (3) ensuring your application meets applicable standards, and any other safety, security, regulatory or other requirements.

These resources are subject to change without notice. TI grants you permission to use these resources only for development of an application that uses the TI products described in the resource. Other reproduction and display of these resources is prohibited. No license is granted to any other TI intellectual property right or to any third party intellectual property right. TI disclaims responsibility for, and you will fully indemnify TI and its representatives against, any claims, damages, costs, losses, and liabilities arising out of your use of these resources.

TI's products are provided subject to [TI's Terms of Sale](#) or other applicable terms available either on [ti.com](https://www.ti.com) or provided in conjunction with such TI products. TI's provision of these resources does not expand or otherwise alter TI's applicable warranties or warranty disclaimers for TI products.

TI objects to and rejects any additional or different terms you may have proposed.

Mailing Address: Texas Instruments, Post Office Box 655303, Dallas, Texas 75265  
Copyright © 2023, Texas Instruments Incorporated

## Looking for pricing, stock, or lifecycle information?

Click below to explore more details on WIN SOURCE:

 [View MSP430FG437IPNR on WIN SOURCE](#)

 [Texas Instruments](#) Information

## Optimize Your Supply Chain with WIN SOURCE Solutions

-  Global Sourcing Solution
-  Obsolete Management
-  Cost Control Management
-  Shortage Management
-  Alternative Solution
-  Excess Inventory Management