



MACRONIX
INTERNATIONAL Co., LTD.

MX29LV160D T/B

MX29LV160D T/B

DATASHEET

Contents

FEATURES	5
GENERAL DESCRIPTION	6
PIN CONFIGURATIONS	7
PIN DESCRIPTION	9
BLOCK DIAGRAM	10
BLOCK DIAGRAM DESCRIPTION	11
BLOCK STRUCTURE	12
Table 1-1. MX29LV160DT SECTOR ARCHITECTURE	12
Table 1-2. MX29LV160DB SECTOR ARCHITECTURE	13
BUS OPERATION	14
Table 2-1. BUS OPERATION	14
Table 2-2. BUS OPERATION	15
FUNCTIONAL OPERATION DESCRIPTION	16
WRITE COMMANDS/COMMAND SEQUENCES.....	16
REQUIREMENTS FOR READING ARRAY DATA.....	16
RESET# OPERATION	17
SECTOR PROTECT OPERATION	17
CHIP UNPROTECT OPERATION.....	17
HARDWARE WRITE PROTECT.....	17
ACCELERATED PROGRAMMING OPERATION	17
TEMPORARY SECTOR UNPROTECT OPERATION	18
AUTOMATIC SELECT OPERATION.....	18
VERIFY SECTOR PROTECT STATUS OPERATION.....	18
DATA PROTECTION.....	18
LOW VCC WRITE INHIBIT	18
WRITE PULSE "GLITCH" PROTECTION.....	18
LOGICAL INHIBIT	19
POWER-UP SEQUENCE	19
POWER-UP WRITE INHIBIT	19
POWER SUPPLY DECOUPLING	19
COMMAND OPERATIONS	20
TABLE 3. MX29LV160D T/B COMMAND DEFINITIONS.....	20
AUTOMATIC PROGRAMMING OF THE MEMORY ARRAY	21
ERASING THE MEMORY ARRAY	21
SECTOR ERASE	22
CHIP ERASE.....	23
SECTOR ERASE SUSPEND.....	23
SECTOR ERASE RESUME.....	24
AUTOMATIC SELECT OPERATIONS	24
AUTOMATIC SELECT COMMAND SEQUENCE	24

READ MANUFACTURER ID OR DEVICE ID	25
VERIFY SECTOR GROUP PROTECTION.....	25
RESET	25
COMMON FLASH MEMORY INTERFACE (CFI) MODE	26
QUERY COMMAND AND COMMON FLASH INTERFACE (CFI) MODE.....	26
Table 4-1. CFI mode: Identification Data Values	26
Table 4-2. CFI Mode: System Interface Data Values	26
Table 4-3. CFI Mode: Device Geometry Data Values.....	27
Table 4-4. CFI Mode: Primary Vendor-Specific Extended Query Data Values.....	28
ELECTRICAL CHARACTERISTICS	29
ABSOLUTE MAXIMUM STRESS RATINGS.....	29
OPERATING TEMPERATURE AND VOLTAGE.....	29
DC CHARACTERISTICS	30
SWITCHING TEST CIRCUIT	31
SWITCHING TEST WAVEFORM.....	31
AC CHARACTERISTICS	32
WRITE COMMAND OPERATION.....	33
Figure 1. COMMAND WRITE OPERATION.....	33
READ/RESET OPERATION	34
Figure 2. READ TIMING WAVEFORM.....	34
Figure 3. RESET# TIMING WAVEFORM.....	35
ERASE/PROGRAM OPERATION	36
Figure 4. AUTOMATIC CHIP ERASE TIMING WAVEFORM	36
Figure 5. AUTOMATIC CHIP ERASE ALGORITHM FLOWCHART.....	37
Figure 6. AUTOMATIC SECTOR ERASE TIMING WAVEFORM.....	38
Figure 7. AUTOMATIC SECTOR ERASE ALGORITHM FLOWCHART	39
Figure 8. ERASE SUSPEND/RESUME FLOWCHART	40
Figure 9. AUTOMATIC PROGRAM TIMING WAVEFORM.....	41
Figure 10. ACCELERATED PROGRAM TIMING DIAGRAM	41
Figure 11. CE# CONTROLLED WRITE TIMING WAVEFORM.....	42
Figure 12. AUTOMATIC PROGRAMMING ALGORITHM FLOWCHART.....	43
SECTOR PROTECT/CHIP UNPROTECT	44
Figure 13. SECTOR PROTECT/CHIP UNPROTECT WAVEFORM (RESET# Control)	44
Figure 14. IN-SYSTEM SECTOR PROTECT WITH RESET#=Vhv	45
Figure 15. CHIP UNPROTECT ALGORITHMS WITH RESET#=Vhv	46
Table 5. TEMPORARY SECTOR UNPROTECT.....	47
Figure 16. TEMPORARY SECTOR UNPROTECT WAVEFORM	47
Figure 17. TEMPORARY SECTOR UNPROTECT FLOWCHART.....	48
Figure 18. SILICON ID READ TIMING WAVEFORM.....	49
WRITE OPERATION STATUS.....	50
Figure 19. DATA# POLLING TIMING WAVEFORM (DURING AUTOMATIC ALGORITHM).....	50
Figure 20. DATA# POLLING ALGORITHM	51



Figure 21. TOGGLE BIT TIMING WAVEFORM (DURING AUTOMATIC ALGORITHM)..... 52
Figure 22. TOGGLE BIT ALGORITHM..... 53
Figure 23. BYTE# TIMING WAVEFORM FOR READ OPERATIONS (BYTE# switching from byte mode to word mode) 54
RECOMMENDED OPERATING CONDITIONS..... 55
ERASE AND PROGRAMMING PERFORMANCE 56
DATA RETENTION 56
LATCH-UP CHARACTERISTICS 56
ORDERING INFORMATION 57
PART NAME DESCRIPTION 58
PACKAGE INFORMATION..... 59
REVISION HISTORY 65

16M-BIT [2M x 8 / 1M x 16] 3V SUPPLY FLASH MEMORY

FEATURES

GENERAL FEATURES

- Byte/Word mode switchable
 - 2,097,152 x8 / 1,048,576 x16
- Sector Structure
 - 16K-Byte x 1, 8K-Byte x 2, 32K-Byte x 1, 64K-Byte x 31
 - Provides sector protect function to prevent program or erase operation in the protected sector
 - Provides chip unprotect function to allow code changing
 - Provides temporary sector unprotect function for code changing in previously protected sector
- Power Supply Operation
 - Vcc 2.7 to 3.6 volt for read, erase, and program operations
- Latch-up protected to 100mA from -1V to 1.5 x Vcc
- Low Vcc write inhibit : Vcc ≤ Vlko
- Compatible with JEDEC standard
 - Pinout and software compatible to single power supply Flash
- **Functional compatible with MX29LV160C device**

PERFORMANCE

- High Performance
 - Fast access time: 70ns
 - Word program time: 11us/word (typical)
 - Fast erase time: 0.7s/sector, 15s/chip (typical)
- Low Power Consumption
 - Low active read current: 5mA (typical) at 5MHz
 - Low standby current: 5uA (typical)
- Typical 100,000 erase/program cycle
- 20 years data retention

SOFTWARE FEATURES

- Erase Suspend/ Erase Resume
 - Suspends sector erase operation to read data from or program data to another sector which is not being erased
- Status Reply
 - Data# Polling & Toggle bits provide detection of program and erase operation completion
- Support Common Flash Interface (CFI)

HARDWARE FEATURES

- Ready/Busy# (RY/BY#) Output
 - Provides a hardware method of detecting program and erase operation completion
- Hardware Reset (RESET#) Input
 - Provides a hardware method to reset the internal state machine to read mode
- WP#/ACC
 - Provide accelerated program capability

PACKAGE

- 48-Pin TSOP
- 48-Ball CSP (TFBGA)
- 48-Ball WFBGA/XFLGA
- **All devices are RoHS Compliant**

GENERAL DESCRIPTION

MX29LV160DT/B is a 16Mbit flash memory that can be organized as 2Mbytes of 8 bits each or as 1Mwords of 16 bits each. These devices operate over a voltage range of 2.7V to 3.6V typically using a 3V power supply input. The memory array is divided into 32 equal 64 Kilo byte blocks. However, depending on the device being used as a Top-Boot or Bottom-Boot device. The outermost one sector at the top or at the bottom are respectively the boot blocks for this device.

The MX29LV160DT/B is offered in a 48-pin TSOP, 48-ball XFLGA/WFBGA and a 48-ball CSP(TFBGA) JEDEC standard package. These packages are offered in leaded, as well as lead-free versions that are compliant to the RoHS specifications. The software algorithm used for this device also adheres to the JEDEC standard for single power supply devices. These flash parts can be programmed in system or on commercially available EPROM/Flash programmers.

Separate OE# and CE# (Output Enable and Chip Enable) signals are provided to simplify system design. When used with high speed processors, the 70ns read access time of this flash memory permits operation with minimal time lost due to system timing delays.

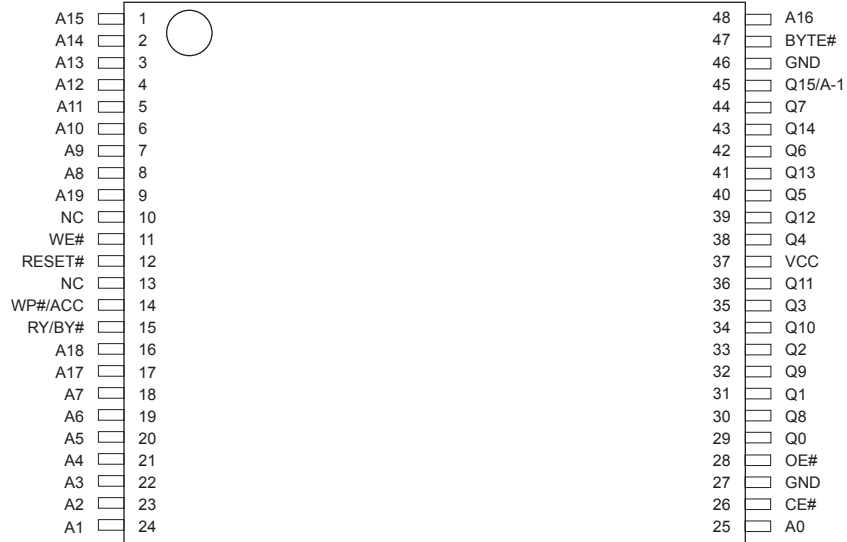
The automatic write algorithm provided on Macronix flash memories perform an automatic erase prior to write. The user only needs to provide a write command to the command register. The on-chip state machine automatically controls the program and erase functions including all necessary internal timings. Since erase and write operations take much longer time than read operations, erase/write can be interrupted to perform read operations in other sectors of the device. For this, Erase Suspend operation along with Erase Resume operation are provided. Data# polling or Toggle bits are used to indicate the end of the erase/write operation.

These devices are manufactured at the Macronix fabrication facility using the time tested and proven Macronix's advance technology. This proprietary non-epi process provides a very high degree of latch-up protection for stresses up to 100 milliamperes on address and data pins from -1V to 1.5xVCC.

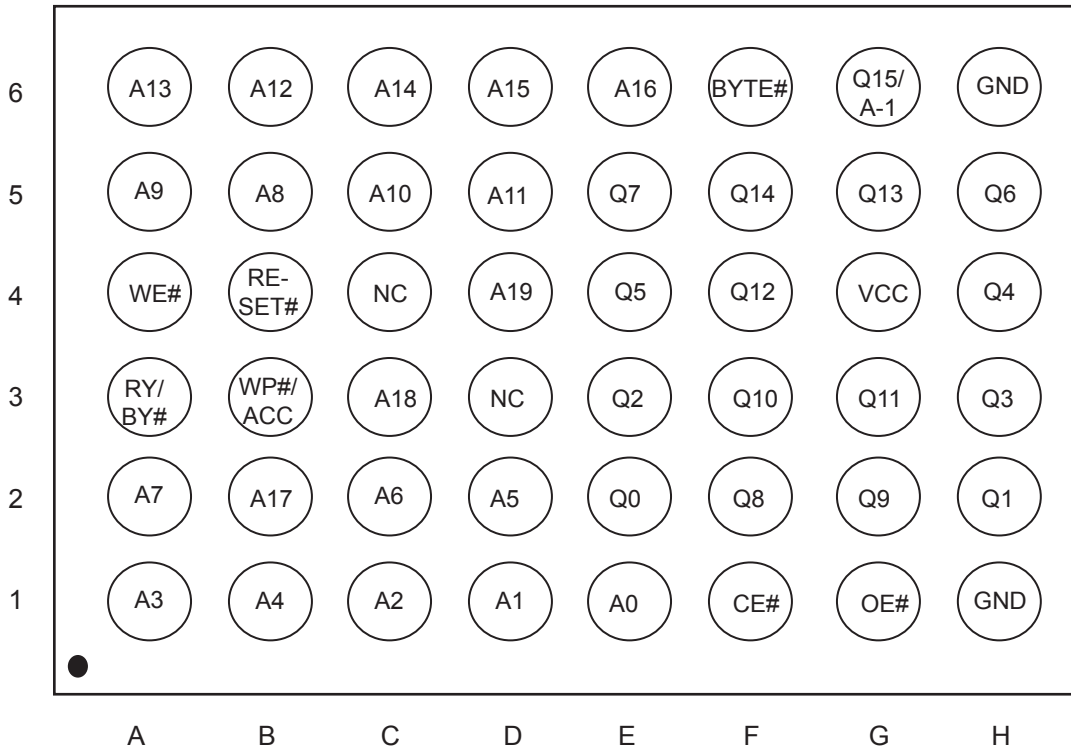
With low power consumption and enhanced hardware and software features, this flash memory retains data reliably for at least twenty years. Erase and programming functions have been tested to meet a typical specification of 100,000 cycles of operation.

PIN CONFIGURATIONS

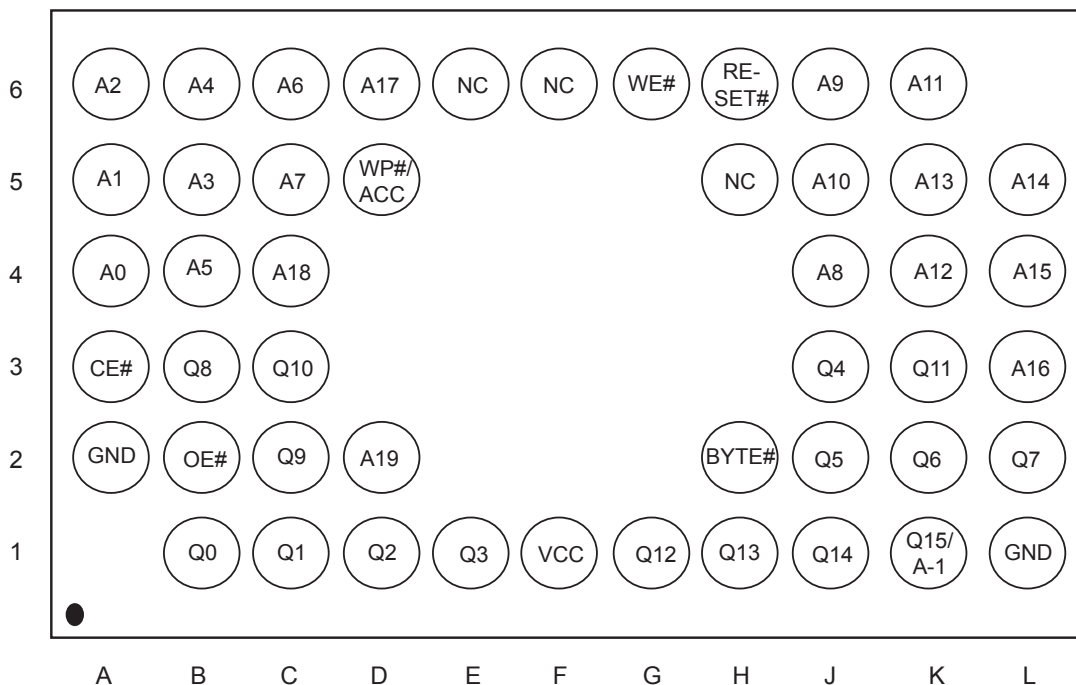
48 TSOP (Standard Type) (12mm x 20mm)



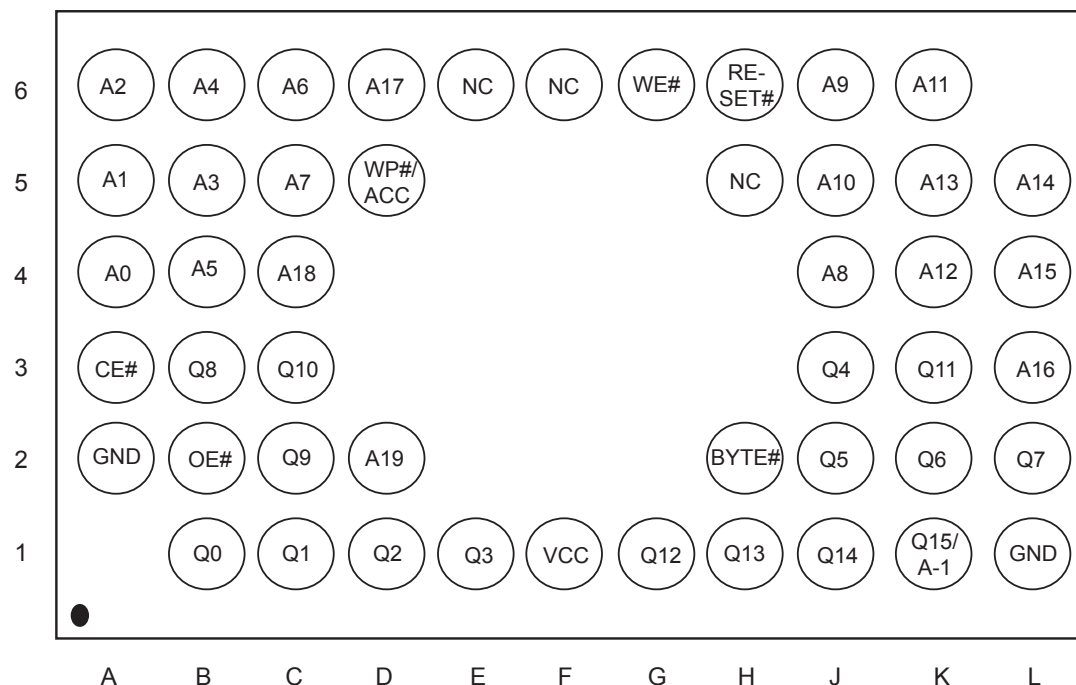
48-Ball CSP(TFBGA/LFBGA) (Ball Pitch = 0.8 mm, Top View, Balls Facing Down, 6 x 8 mm)



48-Ball WFBGA (Balls Facing Down, 4 x 6 x 0.75 mm)



48-Ball XFLGA (Balls Facing Down, 4 x 6 x 0.5 mm)

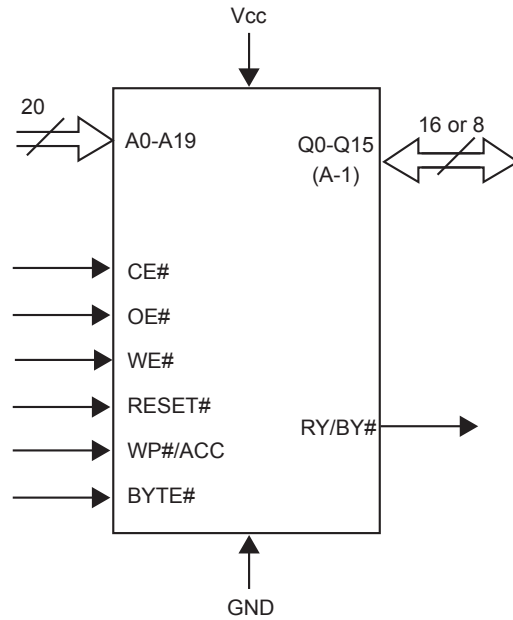


PIN DESCRIPTION

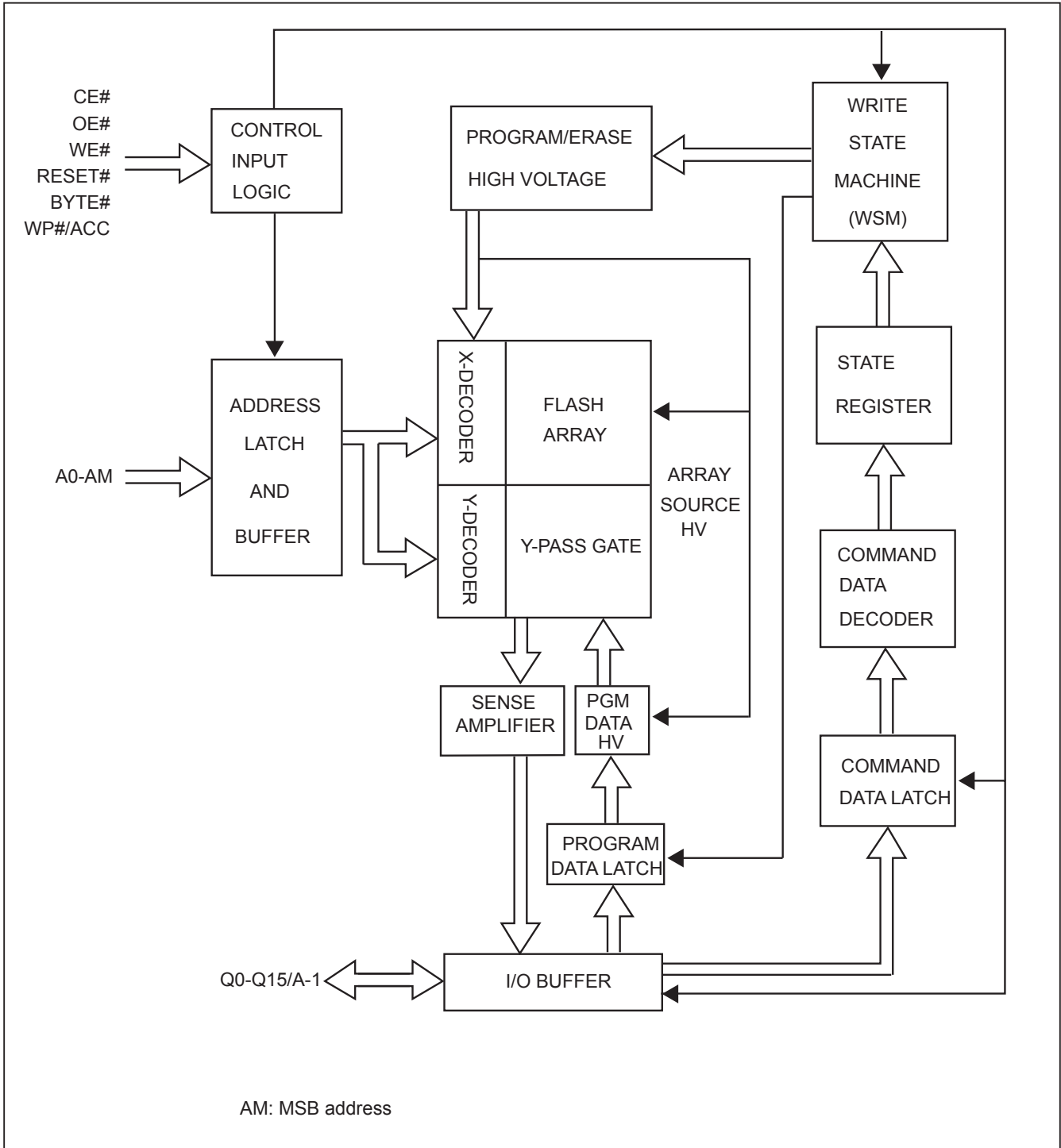
SYMBOL	PIN NAME
A0~A19	Address Input
Q0~Q14	Data Input/Output
Q15/A-1	Q15(Word mode)/LSB addr(Byte mode)
CE#	Chip Enable Input
WE#	Write Enable Input
BYTE#	Word/Byte Selection input
RESET#	Hardware Reset Pin/Sector Protect Unlock
OE#	Output Enable Input
RY/BY#	Ready/Busy Output
VCC	Power Supply Pin (2.7V~3.6V)
GND	Ground Pin
WP#/ACC	Hardware write Protect/Acceleration Pin
NC	Pin Not Connected Internally

Note: If customer does not need WP#/ACC feature please connect WP#/ACC pin to VCC or let it floating. The WP#/ACC has an internal pull-up when unconnected WP#/ACC is at Vih.

LOGIC SYMBOL



BLOCK DIAGRAM



BLOCK DIAGRAM DESCRIPTION

The block diagram on Page 10 illustrates a simplified architecture of MX29LV160D T/B. Each block in the block diagram represents one or more circuit modules in the real chip used to access, erase, program, and read the memory array.

The "CONTROL INPUT LOGIC" block receives input pins CE#, OE#, WE#, RESET#, BYTE# and WP#/ACC. It creates internal timing control signals according to the input pins and outputs to the "ADDRESS LATCH AND BUFFER" to latch the external address pins A0-AM(A19). The internal addresses are output from this block to the main array and decoders composed of "X-DECODER", "Y-DECODER", "Y-PASS GATE", and "FLASH ARRAY". The X-DECODER decodes the word-lines of the flash array, while the Y-DECODER decodes the bit-lines of the flash array. The bit lines are electrically connected to the "SENSE AMPLIFIER" and "PGM DATA HV" selectively through the y-pass gates. Sense amplifiers are used to read out the contents of the flash memory, while the "PGM DATA HV" block is used to selectively deliver high power to bit-lines during programming. The "I/O BUFFER" controls the input and output on the Q0-Q15/A-1 pads. During read operation, the I/O buffer receives data from sense amplifiers and drives the output pads accordingly. In the last cycle of program command, the I/O buffer transmits the data on Q0-Q15/A-1 to "PROGRAM DATA LATCH", which controls the high power drivers in "PGM DATA HV" to selectively program the bits in a word or byte according to the user input pattern.

The "PROGRAM/ERASE HIGH VOLTAGE" block comprises the circuits to generate and deliver the necessary high voltage to the X-DECODER flash array, and "PGM DATA HV" block. The logic control module comprises of the "WRITE STATE MACHINE(WSM)", "STATE REGISTER", "COMMAND DATA DECODER", and "COMMAND DATA LATCH". When the user issues a command by toggling WE#, the command on Q0-A15/A-1 is latched in the command data latch and is decoded by the command data decoder. The state register receives the command and records the current state of the device. The WSM implements the internal algorithms for program or erase according to the current command state by controlling each block in the block diagram.

BLOCK STRUCTURE

The main flash memory array can be organized as 2M Bytes x 8 or as 1M Words x 16. The details of the address ranges and the corresponding sector addresses are shown in Table 1. Table 1.a shows the sector architecture for the Top Boot part, whereas Table 1.b shows the sector architecture for the Bottom Boot part. The specific security sector addresses are shown at the bottom off each of these tables.

Table 1-1. MX29LV160DT SECTOR ARCHITECTURE

Sector Size		Sector	Sector Address A19-A12	Address Range	
Byte Mode (Kbytes)	Word Mode (Kwords)			Byte Mode (x8)	Word Mode (x16)
64	32	SA0	00000xxx	000000h-00FFFFh	000000h-07FFFh
64	32	SA1	00001xxx	010000h-01FFFFh	008000h-0FFFFh
64	32	SA2	00010xxx	020000h-02FFFFh	010000h-17FFFh
64	32	SA3	00011xxx	030000h-03FFFFh	018000h-01FFFFh
64	32	SA4	00100xxx	040000h-04FFFFh	020000h-027FFFh
64	32	SA5	00101xxx	050000h-05FFFFh	028000h-02FFFFh
64	32	SA6	00110xxx	060000h-06FFFFh	030000h-037FFFh
64	32	SA7	00111xxx	070000h-07FFFFh	038000h-03FFFFh
64	32	SA8	01000xxx	080000h-08FFFFh	040000h-047FFFh
64	32	SA9	01001xxx	090000h-09FFFFh	048000h-04FFFFh
64	32	SA10	01010xxx	0A0000h-0AFFFFh	050000h-057FFFh
64	32	SA11	01011xxx	0B0000h-0BFFFFh	058000h-05FFFFh
64	32	SA12	01100xxx	0C0000h-0CFFFFh	060000h-067FFFh
64	32	SA13	01101xxx	0D0000h-0DFFFFh	068000h-06FFFFh
64	32	SA14	01110xxx	0E0000h-0EFFFFh	070000h-077FFFh
64	32	SA15	01111xxx	0F0000h-0FFFFFh	078000h-07FFFFh
64	32	SA16	10000xxx	100000h-10FFFFh	080000h-087FFFh
64	32	SA17	10001xxx	110000h-11FFFFh	088000h-08FFFFh
64	32	SA18	10010xxx	120000h-12FFFFh	090000h-097FFFh
64	32	SA19	10011xxx	130000h-13FFFFh	098000h-09FFFFh
64	32	SA20	10100xxx	140000h-14FFFFh	0A0000h-0A7FFFh
64	32	SA21	10101xxx	150000h-15FFFFh	0A8000h-0AFFFFh
64	32	SA22	10110xxx	160000h-16FFFFh	0B0000h-0B7FFFh
64	32	SA23	10111xxx	170000h-17FFFFh	0B8000h-0BFFFFh
64	32	SA24	11000xxx	180000h-18FFFFh	0C0000h-0C7FFFh
64	32	SA25	11001xxx	190000h-19FFFFh	0C8000h-0CFFFFh
64	32	SA26	11010xxx	1A0000h-1AFFFFh	0D0000h-0D7FFFh
64	32	SA27	11011xxx	1B0000h-1BFFFFh	0D8000h-0DFFFFh
64	32	SA28	11100xxx	1C0000h-1CFFFFh	0E0000h-0E7FFFh
64	32	SA29	11101xxx	1D0000h-1DFFFFh	0E8000h-0EFFFFh
64	32	SA30	11110xxx	1E0000h-1EFFFFh	0F0000h-0F7FFFh
32	16	SA31	111110xx	1F0000h-1F7FFFh	0F8000h-0FBFFFh
8	4	SA32	11111100	1F8000h-1F9FFFh	0FC000h-0FCFFFh
8	4	SA33	11111101	1FA000h-1FBFFFh	0FD000h-0FDFFFh
16	8	SA34	1111111x	1FC000h-1FFFFFh	0FE000h-0FFFFFh

Table 1-2. MX29LV160DB SECTOR ARCHITECTURE

Sector Size		Sector	Sector Address A19-A12	Address Range	
Byte Mode (Kbytes)	Word Mode (Kwords)			Byte Mode (x8)	Word Mode (x16)
16	8	SA0	0000000x	000000h-003FFFh	000000h-001FFFh
8	4	SA1	00000010	004000h-005FFFh	002000h-002FFFh
8	4	SA2	00000011	006000h-007FFFh	003000h-003FFFh
32	16	SA3	000001xx	008000h-00FFFFh	004000h-007FFFh
64	32	SA4	00001xxx	010000h-01FFFFh	008000h-00FFFFh
64	32	SA5	00010xxx	020000h-02FFFFh	010000h-017FFFh
64	32	SA6	00011xxx	030000h-03FFFFh	018000h-01FFFFh
64	32	SA7	00100xxx	040000h-04FFFFh	020000h-027FFFh
64	32	SA8	00101xxx	050000h-05FFFFh	028000h-02FFFFh
64	32	SA9	00110xxx	060000h-06FFFFh	030000h-037FFFh
64	32	SA10	00111xxx	070000h-07FFFFh	038000h-03FFFFh
64	32	SA11	01000xxx	080000h-08FFFFh	040000h-047FFFh
64	32	SA12	01001xxx	090000h-09FFFFh	048000h-04FFFFh
64	32	SA13	01010xxx	0A0000h-0AFFFFh	050000h-057FFFh
64	32	SA14	01011xxx	0B0000h-0BFFFFh	058000h-05FFFFh
64	32	SA15	01100xxx	0C0000h-0CFFFFh	060000h-067FFFh
64	32	SA16	01101xxx	0D0000h-0DFFFFh	068000h-06FFFFh
64	32	SA17	01110xxx	0E0000h-0EFFFFh	070000h-077FFFh
64	32	SA18	01111xxx	0F0000h-0FFFFFh	078000h-07FFFFh
64	32	SA19	10000xxx	100000h-10FFFFh	080000h-087FFFh
64	32	SA20	10001xxx	110000h-11FFFFh	088000h-08FFFFh
64	32	SA21	10010xxx	120000h-12FFFFh	090000h-097FFFh
64	32	SA22	10011xxx	130000h-13FFFFh	098000h-09FFFFh
64	32	SA23	10100xxx	140000h-14FFFFh	0A0000h-0A7FFFh
64	32	SA24	10101xxx	150000h-15FFFFh	0A8000h-0AFFFFh
64	32	SA25	10110xxx	160000h-16FFFFh	0B0000h-0B7FFFh
64	32	SA26	10111xxx	170000h-17FFFFh	0B8000h-0BFFFFh
64	32	SA27	11000xxx	180000h-18FFFFh	0C0000h-0C7FFFh
64	32	SA28	11001xxx	190000h-19FFFFh	0C8000h-0CFFFFh
64	32	SA29	11010xxx	1A0000h-1AFFFFh	0D0000h-0D7FFFh
64	32	SA30	11011xxx	1B0000h-1BFFFFh	0D8000h-0DFFFFh
64	32	SA31	11100xxx	1C0000h-1CFFFFh	0E0000h-0E7FFFh
64	32	SA32	11101xxx	1D0000h-1DFFFFh	0E8000h-0EFFFFh
64	32	SA33	11110xxx	1E0000h-1EFFFFh	0F0000h-0F7FFFh
64	32	SA34	11111xxx	1F0000h-1FFFFFh	0F8000h-0FFFFFh

BUS OPERATION

Table 2-1. BUS OPERATION

Mode Select	RE-SET#	CE#	WE#	OE#	Address	Data I/O Q7~Q0	Byte#		WP#/ACC
							Vil	Vih	
							Data (I/O) Q15~Q8		
Device Reset	L	X	X	X	X	HighZ	HighZ	HighZ	L/H
Standby Mode	V _{cc} ± 0.3V	V _{cc} ± 0.3V	X	X	X	HighZ	HighZ	HighZ	H
Output Disable	H	L	H	H	X	HighZ	HighZ	HighZ	L/H
Read Mode	H	L	H	L	AIN	DOUT	Q8-Q14= HighZ, Q15=A-1	DOUT	L/H
Write	H	L	L	H	AIN	DIN		DIN	Note3
Accelerate Program	H	L	L	H	AIN	DIN		DIN	Vhv
Temporary Sector Unprotect	Vhv	X	X	X	AIN	DIN	HighZ	DIN	Note3
Sector Protect (Note2)	Vhv	L	L	H	Sector Address, A6=L, A1=H, A0=L	DIN, DOUT	X	X	L/H
Chip Unprotect (Note2)	Vhv	L	L	H	Sector Address, A6=H, A1=H, A0=L	DIN, DOUT	X	X	Note3

Notes:

1. All sectors will be unprotected if WP#/ACC=Vhv.
2. The one outmost boot sector is protected if WP#/ACC=Vil.
3. When WP#/ACC = Vih, the protection conditions of the one outmost boot sector depend on previous protection conditions."Sector/Sector Block Protection and Unprotection" describes the protect and unprotect method.
4. Q0~Q15 are input (DIN) or output (DOUT) pins according to the requests of command sequence, sector protection, or data polling algorithm.
5. In Word Mode (Byte#=Vih), the addresses are AM to A0.
In Byte Mode (Byte#=Vil), the addresses are AM to A-1 (Q15).
6. AM: MSB of address.

Table 2-2. BUS OPERATION

Item	Control Input			AM to A12	A11 to A10	A9	A8 to A7	A6	A5 to A2	A1	A0	Q7 ~ Q0	Q15 ~ Q8
	CE#	WE#	OE#										
Sector Lock Status Verification	L	H	L	SA	x	V _{hv}	x	L	x	H	L	01h or 00h (Note 1)	x
Read Silicon ID Manufacturer Code	L	H	L	x	x	V _{hv}	x	L	x	L	L	C2h	x
Read Silicon ID MX29LV160DT	L	H	L	x	x	V _{hv}	x	L	x	L	H	C4h	22h(Word)
													x (Byte)
Read Silicon ID MX29LV160DB	L	H	L	x	x	V _{hv}	x	L	x	L	H	49h	22h(Word)
													x (Byte)

Notes:

1. Sector unprotected code:00h. Sector protected code:01h.
2. AM: MSB of address.

FUNCTIONAL OPERATION DESCRIPTION

WRITE COMMANDS/COMMAND SEQUENCES

To write a command to the device, system must drive WE# and CE# to Vil, and OE# to Vih. In a command cycle, all address are latched at the later falling edge of CE# and WE#, and all data are latched at the earlier rising edge of CE# and WE#.

Figure 1 illustrates the AC timing waveform of a write command, and Table 3 defines all the valid command sets of the device. System is not allowed to write invalid commands not defined in this datasheet. Writing an invalid command will bring the device to an undefined state.

REQUIREMENTS FOR READING ARRAY DATA

Read array action is to read the data stored in the array. While the memory device is in powered up or has been reset, it will automatically enter the status of read array. If the microprocessor wants to read the data stored in array, it has to drive CE# (device enable control pin) and OE# (Output control pin) as Vil, and input the address of the data to be read into address pin at the same time. After a period of read cycle (Tce or Taa), the data being read out will be displayed on output pin for microprocessor to access. If CE# or OE# is Vih, the output will be in tri-state, and there will be no data displayed on output pin at all.

After the memory device completes embedded operation (automatic Erase or Program), it will automatically return to the status of read array, and the device can read the data in any address in the array. In the process of erasing, if the device receives the Erase suspend command, erase operation will be stopped temporarily after a period of time no more than Tready1 and the device will return to the status of read array. At this time, the device can read the data stored in any address except the sector being erased in the array. In the status of erase suspend, if user wants to read the data in the sectors being erased, the device will output status data onto the output. Similarly, if program command is issued after erase suspend, after program operation is completed, system can still read array data in any address except the sectors to be erased

The device needs to issue reset command to enable read array operation again in order to arbitrarily read the data in the array in the following two situations:

1. In program or erase operation, the programming or erasing failure causes Q5 to go high.
2. The device is in auto select mode or CFI mode.

In the two situations above, if reset command is not issued, the device is not in read array mode and system must issue reset command before reading array data.

RESET# OPERATION

Driving RESET# pin low for a period more than T_{rp} will reset the device back to read mode. If the device is in program or erase operation, the reset operation will take at most a period of T_{ready1} for the device to return to read array mode. Before the device returns to read array mode, the RY/BY# pin remains low (busy status).

When RESET# pin is held at $GND \pm 0.3V$, the device consumes standby current (I_{sb}). However, device draws larger current if RESET# pin is held at V_{il} but not within $GND \pm 0.3V$.

It is recommended that the system to tie its reset signal to RESET# pin of flash memory, so that the flash memory will be reset during system reset and allows system to read boot code from flash memory.

SECTOR PROTECT OPERATION

When a sector is protected, program or erase operation will be disabled on that protected sector. MX29LV160D T/B provides two methods for sector protection.

Once the sector is protected, the sector remains protected until next chip unprotect, or is temporarily unprotected by asserting RESET# pin at V_{hv} . Refer to temporary sector unprotect operation for further details.

The first method is by applying V_{hv} on RESET# pin. Refer to Figure 12 for timing diagram and Figure 13 for the algorithm for this method.

The other method is asserting V_{hv} on A9 and OE# pins, with A6 and CE# at V_{il} . The protection operation begins at the falling edge of WE# and terminates at the rising edge. Contact Macronix for details.

CHIP UNPROTECT OPERATION

MX29LV160D T/B provides two methods for chip unprotect. The chip unprotect operation unprotects all sectors within the device. It is recommended to protect all sectors before activating chip unprotect mode. All sectors are unprotected when shipped from the factory.

The first method is by applying V_{hv} on RESET# pin. Refer to Figure 12 for timing diagram and Figure 14 for algorithm of the operation.

The other method is asserting V_{hv} on A9 and OE# pins, with A6 at V_{ih} and CE# at V_{il} . The unprotect operation begins at the falling edge of WE# and terminates at the rising edge. Contact Macronix for details.

HARDWARE WRITE PROTECT

By driving the WP#/ACC pin LOW, the outermost one boot sector is protected from all erase/program operations. If WP#/ACC is held HIGH (V_{ih} to VCC), the one outermost sector revert to its previously protected/unprotected status.

ACCELERATED PROGRAMMING OPERATION

By applying high voltage (V_{hv}) to the WP#/ACC pin, the device will enter the Accelerated Programming mode. This mode permits the system to skip the normal command unlock sequences and program byte/word locations directly. During accelerated programming, the current drawn from the WP#/ACC pin is no more than ICP1.

TEMPORARY SECTOR UNPROTECT OPERATION

System can apply RESET# pin at V_{hv} to place the device in temporary unprotect mode. In this mode, previously protected sectors can be programmed or erased just as it is unprotected. The device returns to normal operation once V_{hv} is removed from RESET# pin and previously protected sectors are again protected.

AUTOMATIC SELECT OPERATION

When the device is in Read array mode, erase-suspended read array mode or CFI mode, user can issue read silicon ID command to enter read silicon ID mode. After entering read silicon ID mode, user can query several silicon IDs continuously and does not need to issue read silicon ID mode again. When A0 is Low, device will output Macronix Manufacture ID C2. When A0 is high, device will output Device ID. In read silicon ID mode, issuing reset command will reset device back to read array mode or erase-suspended read array mode.

Another way to enter read silicon ID is to apply high voltage on A9 pin with CE#, OE#, A6 and A1 at V_{il}. While the high voltage of A9 pin is discharged, device will automatically leave read silicon ID mode and go back to read array mode or erase-suspended read array mode. When A0 is Low, device will output Macronix Manufacture ID C2. When A0 is high, device will output Device ID.

VERIFY SECTOR PROTECT STATUS OPERATION

MX29LV160D T/B provides hardware sector protection against Program and Erase operation for protected sectors. The sector protect status can be read through Sector Protect Verify command. This method requires V_{hv} on A9 pin, V_{ih} on WE# and A1 pins, V_{il} on CE#, OE#, A6 and A0 pins, and sector address on A12 to A_m pins. If the read out data is 01h, the designated sector is protected. Oppositely, if the read out data is 00h, the designated sector is not protected.

DATA PROTECTION

To avoid accidental erasure or programming of the device, the device is automatically reset to read array mode during power up. Besides, only after successful completion of the specified command sets will the device begin its erase or program operation.

Other features to protect the data from accidental alternation are described as followed.

LOW VCC WRITE INHIBIT

The device refuses to accept any write command when V_{cc} is less than V_{lko}. This prevents data from spuriously altered. The device automatically resets itself when V_{cc} is lower than V_{lko} and write cycles are ignored until V_{cc} is greater than V_{lko}. System must provide proper signals on control pins after V_{cc} is larger than V_{lko} to avoid unintentional program or erase operation

WRITE PULSE "GLITCH" PROTECTION

CE#, WE#, OE# pulses shorter than 5ns are treated as glitches and will not be regarded as an effective write cycle.



LOGICAL INHIBIT

A valid write cycle requires both CE# and WE# at Vil with OE# at Vih. Write cycle is ignored when either CE# at Vih, WE# a Vih, or OE# at Vil.

POWER-UP SEQUENCE

Upon power up, MX29LV160D T/B is placed in read array mode. Furthermore, program or erase operation will begin only after successful completion of specified command sequences.

POWER-UP WRITE INHIBIT

When WE#, CE# is held at Vil and OE# is held at Vih during power up, the device ignores the first command on the rising edge of WE#.

POWER SUPPLY DECOUPLING

A 0.1uF capacitor should be connected between the Vcc and GND to reduce the noise effect.

COMMAND OPERATIONS

TABLE 3. MX29LV160D T/B COMMAND DEFINITIONS

Command		Read Mode	Reset Mode	Automatic Select					
				Manufacture ID		Device ID		Sector Protect Verify	
				Word	Byte	Word	Byte	Word	Byte
1st Bus Cycle	Addr	Addr	XXX	555	AAA	555	AAA	555	AAA
	Data	Data	F0	AA	AA	AA	AA	AA	AA
2nd Bus Cycle	Addr			2AA	555	2AA	555	2AA	555
	Data			55	55	55	55	55	55
3rd Bus Cycle	Addr			555	AAA	555	AAA	555	AAA
	Data			90	90	90	90	90	90
4th Bus Cycle	Addr			X00	X00	X01	X02	(Sector)X02	(Sector)X04
	Data			C2h	C2h	ID	ID	00/01	00/01
5th Bus Cycle	Addr								
	Data								
6th Bus Cycle	Addr								
	Data								

Command		Program		Chip Erase		Sector Erase		CFI Read		Erase Suspend	Erase Resume
		Word	Byte	Word	Byte	Word	Byte	Word	Byte	Byte/Word	Byte/Word
1st Bus Cycle	Addr	555	AAA	555	AAA	555	AAA	55	AA	XXX	XXX
	Data	AA	AA	AA	AA	AA	AA	98	98	B0	30
2nd Bus Cycle	Addr	2AA	555	2AA	555	2AA	555				
	Data	55	55	55	55	55	55				
3rd Bus Cycle	Addr	555	AAA	555	AAA	555	AAA				
	Data	A0	A0	80	80	80	80				
4th Bus Cycle	Addr	Addr	Addr	555	AAA	555	AAA				
	Data	Data	Data	AA	AA	AA	AA				
5th Bus Cycle	Addr			2AA	555	2AA	555				
	Data			55	55	55	55				
6th Bus Cycle	Addr			555	AAA	Sector	Sector				
	Data			10	10	30	30				

Notes:

1. Device ID : MX29LV160DT: 22C4; MX29LV160DB: 2249.
2. For sector protect verify result, XX00h/00h means sector is not protected, XX01h/01h means sector has been protected.
3. Sector Protect command is valid during V_{hv} at RESET# pin, V_{ih} at A1 pin and V_{il} at A0, A6 pins. The last Bus cyc is for protect verify.
4. It is not allowed to adopt any other code which is not in the above command definition table.

COMMAND OPERATIONS (cont'd)

AUTOMATIC PROGRAMMING OF THE MEMORY ARRAY

The MX29LV160D T/B provides the user the ability to program the memory array in Byte mode or Word mode. As long as the users enters the correct cycle defined in the Table 3 (including 2 unlock cycles and the A0h program command), any byte or word data provided on the data lines by the system will automatically be programmed into the array at the specified location.

After the program command sequence has been executed, the internal write state machine (WSM) automatically executes the algorithms and timings necessary for programming and verification, which includes generating suitable program pulses, checking cell threshold voltage margins, and repeating the program pulse if any cells do not pass verification or have low margins. The internal controller protects cells that do pass verification and margin tests from being over-programmed by inhibiting further program pulses to these passing cells as weaker cells continue to be programmed.

With the internal WSM automatically controlling the programming process, the user only needs to enter the program command and data once.

Programming will only change the bit status from "1" to "0". It is not possible to change the bit status from "0" to "1" by programming. This can only be done by an erase operation. Furthermore, the internal write verification only checks and detects errors in cases where a "1" is not successfully programmed to "0".

Any commands written to the device during programming will be ignored except hardware reset, which will terminate the program operation after a period of time no more than Tready1. When the embedded program algorithm is complete or the program operation is terminated by a hardware reset, the device will return to Read mode.

After the embedded program operation has begun, the user can check for completion by reading the following bits in the status register:

Status	Q7	Q6	Q5	RY/BY# *2
In progress *3	Q7#	Toggling	0	0
Finished	Q7	Stop toggling	0	1
Exceed time limit	Q7#	Toggling	1	0

*1: When an attempt is made to program a protected sector, the program operation will abort thus preventing any data changes in the protected sector. Q7 will output complement data and Q6 will toggle briefly (1us or less) before aborting and returning the device to Read mode.

*2: RY/BY# is an open drain output pin and should be connected to VCC through a high value pull-up resistor.

*3: The status "in progress" means both program and erase-suspended program mode.

ERASING THE MEMORY ARRAY

There are two types of erase operations performed on the memory array -- Sector Erase and Chip Erase. In the Sector Erase operation, one or more selected sectors may be erased simultaneously. In the Chip Erase operation, the complete memory array is erased except for any protected sectors.

COMMAND OPERATIONS (cont'd)**SECTOR ERASE**

The sector erase operation is used to clear data within a sector by returning all of its memory locations to the "1" state. It requires six command cycles to initiate the erase operation. The first two cycles are "unlock cycles", the third is a configuration cycle, the fourth and fifth are also "unlock cycles", and the sixth cycle is the Sector Erase command. After the sector erase command sequence has been issued, an internal 50us time-out counter is started. Until this counter reaches zero, additional sector addresses and Sector Erase commands may be issued thus allowing multiple sectors to be selected and erased simultaneously. After the 50us time-out counter has expired, no new commands will be accepted and the embedded sector erase operation will begin. Note that the 50us timer-out counter is restarted after every erase command sequence. If the user enters any command other than Sector Erase or Erase Suspend during the time-out period, the erase operation will abort and the device will return to Read mode.

After the embedded sector erase operation begins, all commands except Erase Suspend will be ignored. The only way to interrupt the operation is with an Erase Suspend command or with a hardware reset. The hardware reset will completely abort the operation and return the device to Read mode.

The system can determine the status of the embedded sector erase operation by the following methods:

Status	Q7	Q6	Q5	Q3 (*1)	Q2	RY/BY#(*2)
Time-out period	0	Toggling	0	0	Toggling	0
In progress	0	Toggling	0	1	Toggling	0
Finished	1	Stop toggling	0	1	1	1
Exceeded time limit	0	Toggling	1	1	Toggling	0

Note :

- *1. The Q3 status bit is the time-out indicator. When Q3=0, the time-out counter has not yet reached zero and a new Sector Erase command may be issued to specify the address of another sector to be erased. When Q3=1, the time-out counter has expired and the Sector Erase operation has already begun. Erase Suspend is the only valid command that may be issued once the embedded erase operation is underway.
- *2. RY/BY# is an open drain output pin and should be connected to VCC through a high value pull-up resistor.
- *3. When an attempt is made to erase only protected sector(s), the program operation will abort thus preventing any data changes in the protected sector(s). Q7 will output its complement data and Q6 will toggle briefly (100us or less) before aborting and returning the device to Read mode. If unprotected sectors are also specified, however, they will be erased normally and the protected sector(s) will remain unchanged.
- *4. Q2 is a localized indicator showing a specified sector is undergoing erase operation or not. Q2 toggles when user reads at addresses where the sectors are actively being erased (in erase mode) or to be erased (in erase suspend mode). When a sector has been completely erased, Q2 stops toggling at the sector even when the device is still in erase operation for remaining selected sectors. At that circumstance, Q2 will still toggle when device is read at any other sector that remains to be erased.

COMMAND OPERATIONS (cont'd)**CHIP ERASE**

The Chip Erase operation is used to erase all the data within the memory array. All memory cells containing a "0" will be returned to the erased state of "1". This operation requires 6 write cycles to initiate the action. The first two cycles are "unlock" cycles, the third is a configuration cycle, the fourth and fifth are also "unlock" cycles, and the sixth cycle initiates the chip erase operation.

During the chip erase operation, no other software commands will be accepted, but if a hardware reset is received or the working voltage is too low, that chip erase will be terminated. After Chip Erase, the chip will automatically return to Read mode.

The system can determine the status of the embedded chip erase operation by the following methods:

Status	Q7	Q6	Q5	Q2	RY/BY# ^{*1}
In progress	0	Toggling	0	Toggling	0
Finished	1	Stop toggling	0	1	1
Exceed time limit	0	Toggling	1	Toggling	0

*1: RY/BY# is an open drain output pin and should be connected to VCC through a high value pull-up resistor.

SECTOR ERASE SUSPEND

After beginning a sector erase operation, Erase Suspend is the only valid command that may be issued. If system issues an Erase Suspend command during the 50us time-out period following a Sector Erase command, the time-out period will terminate immediately and the device will enter Erase-Suspended Read mode. If the system issues an Erase Suspend command after the sector erase operation has already begun, the device will not enter Erase-Suspended Read mode until Tready1 time has elapsed. The system can determine if the device has entered the Erase-Suspended Read mode through Q6, Q7, and RY/BY#.

After the device has entered Erase-Suspended Read mode, the system can read or program any sector(s) except those being erased by the suspended erase operation. Reading any sector being erased or programmed will return the contents of the status register. Whenever a suspend command is issued, user must issue a resume command and check Q6 toggle bit status, before issue another erase command. The system can use the status register bits shown in the following table to determine the current state of the device:

Status	Q7	Q6	Q5	Q3	Q2	RY/BY#
Erase suspend read in erase suspended sector	1	No toggle	0	N/A	Toggle	1
Erase suspend read in non-erase suspended sector	Data	Data	Data	Data	Data	1
Erase suspend program in non-erase suspended sector	Q7#	Toggle	0	N/A	N/A	0

When the device has suspended erasing, user can execute the command sets except sector erase and chip erase, such as read silicon ID, sector protect verify, program, CFI query and erase resume.

COMMAND OPERATIONS (cont'd)**SECTOR ERASE RESUME**

The sector Erase Resume command is valid only when the device is in Erase-Suspended Read mode. After erase resumes, the user can issue another Erase Suspend command, but there should be a 4ms interval between Erase Resume and the next Erase Suspend command. If the user enters an infinite suspend-resume loop, or suspend-resume exceeds 1024 times, erase times will increase dramatically.

AUTOMATIC SELECT OPERATIONS

When the device is in Read mode, Erase-Suspended Read mode, or CFI mode, the user can issue the Automatic Select command shown in Table 3 (two unlock cycles followed by the Automatic Select command 90h) to enter Automatic Select mode. After entering Automatic Select mode, the user can query the Manufacturer ID, Device ID, Security Sector locked status, or Sector-Group protected status multiple times without issuing a new Automatic Select command.

While In Automatic Select mode, issuing a Reset command (F0h) will return the device to Read mode (or Erase-Suspended Read mode if Erase-Suspend was active).

Another way to enter Automatic Select mode is to use one of the bus operations shown in Table 2-2. BUS OPERATION. After the high voltage (V_{hv}) is removed from the A9 pin, the device will automatically return to Read mode or Erase-Suspended Read mode.

AUTOMATIC SELECT COMMAND SEQUENCE

Automatic Select mode is used to access the manufacturer ID, device ID and to verify whether or not a sector is protected. The automatic select mode has four command cycles. The first two are unlock cycles, and followed by a specific command. The fourth cycle is a normal read cycle, and user can read at any address any number of times without entering another command sequence. The reset command is necessary to exit the Automatic Select mode and back to read array. The following table shows the identification code with corresponding address.

		Address (Hex)	Data (Hex)	Representation
Manufacturer ID	Word	X00	00C2	
	Byte	X00	C2	
Device ID	Word	X01	22C4/2249	Top/Bottom Boot Sector
	Byte	X02	C4/49	Top/Bottom Boot Sector
Sector Protect Verify	Word	(Sector address) X 02	0000/0001	Unprotected/protected
	Byte	(Sector address) X 04	00/01	Unprotected/protected

After entering automatic select mode, no other commands are allowed except the reset command.

COMMAND OPERATIONS (cont'd)

READ MANUFACTURER ID OR DEVICE ID

The Manufacturer ID (identification) is a unique hexadecimal number assigned to each manufacturer by the JEDEC committee. Each company has its own manufacturer ID, which is different from the ID of all other companies. The number assigned to Macronix is C2h.

The Device ID is a unique hexadecimal number assigned by the manufacturer for each one of the flash devices made by that manufacturer.

The above two ID types are stored in a 16-bit register on the flash device -- eight bits for each ID. This register is normally read by the user or by the programming machine to identify the manufacturer and the specific device.

After entering Automatic Select mode, performing a read operation with A1 & A0 held LOW will cause the device to output the Manufacturer ID on the Data I/O (Q7 to Q0) pins. Performing a read operation with A1 LOW and A0 HIGH will cause the device to output the Device ID.

VERIFY SECTOR GROUP PROTECTION

After entering Automatic Select mode, performing a read operation with A1 held HIGH and A0 held LOW and the address of the sector to be checked applied to A19 to A12, data bit Q0 will indicate the protected status of the addressed sector. If Q0 is HIGH, the sector is protected. Conversely, if Q0 is LOW, the sector is unprotected.

RESET

In the following situations, executing reset command will reset device back to read array mode:

- Among erase command sequence (before the full command set is completed)
- Sector erase time-out period
- Erase fail (while Q5 is high)
- Among program command sequence (before the full command set is completed, erase-suspended program included)
- Program fail (while Q5 is high, and erase-suspended program fail is included)
- Read silicon ID mode
- Sector protect verify
- CFI mode

While device is at the status of program fail or erase fail (Q5 is high), user must issue reset command to reset device back to read array mode. While the device is in read silicon ID mode, sector protect verify or CFI mode, user must issue reset command to reset device back to read array mode.

When the device is in the progress of programming (not program fail) or erasing (not erase fail), device will ignore reset command.

COMMON FLASH MEMORY INTERFACE (CFI) MODE

QUERY COMMAND AND COMMON FLASH INTERFACE (CFI) MODE

MX29LV160D T/B features CFI mode. Host system can retrieve the operating characteristics, structure and vendor-specified information such as identifying information, memory size, byte/word configuration, operating voltages and timing information of this device by CFI mode. If the system writes the CFI Query command "98h", to address "55h"/"AAh" (depending on Word/Byte mode), the device will enter the CFI Query Mode, any time the device is ready to read array data. The system can read CFI information at the addresses given in Table 4.

Once user enters CFI query mode, user can not issue any other commands except reset command. The reset command is required to exit CFI mode and go back to the mode before entering CFI. The system can write the CFI Query command only when the device is in read mode, erase suspend, standby mode or automatic select mode.

Table 4-1. CFI mode: Identification Data Values

(All values in these tables are in hexadecimal)

Description	Address (h) (Word Mode)	Address (h) (Byte Mode)	Data (h)
Query-unique ASCII string "QRY"	10	20	0051
	11	22	0052
	12	24	0059
Primary vendor command set and control interface ID code	13	26	0002
	14	28	0000
Address for primary algorithm extended query table	15	2A	0040
	16	2C	0000
Alternate vendor command set and control interface ID code	17	2E	0000
	18	30	0000
Address for alternate algorithm extended query table	19	32	0000
	1A	34	0000

Table 4-2. CFI Mode: System Interface Data Values

Description	Address (h) (Word Mode)	Address (h) (Byte Mode)	Data (h)
Vcc supply minimum program/erase voltage	1B	36	0027
Vcc supply maximum program/erase voltage	1C	38	0036
VPP supply minimum program/erase voltage	1D	3A	0000
VPP supply maximum program/erase voltage	1E	3C	0000
Typical timeout per single word/byte write, 2 ⁿ us	1F	3E	0004
Typical timeout for maximum-size buffer write, 2 ⁿ us	20	40	0000
Typical timeout per individual block erase, 2 ⁿ ms	21	42	000A
Typical timeout for full chip erase, 2 ⁿ ms	22	44	0000
Maximum timeout for word/byte write, 2 ⁿ times typical	23	46	0005
Maximum timeout for buffer write, 2 ⁿ times typical	24	48	0000
Maximum timeout per individual block erase, 2 ⁿ times typical	25	4A	0004
Maximum timeout for chip erase, 2 ⁿ times typical	26	4C	0000

Table 4-3. CFI Mode: Device Geometry Data Values

Description	Address (h) (Word Mode)	Address (h) (Byte Mode)	Data (h)
Device size = 2 ⁿ in number of bytes (MX29LV160D)	27	4E	0015
Flash device interface description (02=asynchronous x8/x16)	28	50	0002
	29	52	0000
Maximum number of bytes in buffer write = 2 ⁿ (not support)	2A	54	0000
	2B	56	0000
Number of erase regions within device	2C	58	0004
Index for Erase Bank Area 1 [2E,2D] = # of same-size sectors in region 1-1 [30, 2F] = sector size in multiples of 256-bytes	2D	5A	0000
	2E	5C	0000
	2F	5E	0040
	30	60	0000
Index for Erase Bank Area 2	31	62	0001
	32	64	0000
	33	66	0020
	34	68	0000
Index for Erase Bank Area 3	35	6A	0000
	36	6C	0000
	37	6E	0080
	38	70	0000
Index for Erase Bank Area 4 (for MX29LV160D)	39	72	001E
	3A	74	0000
	3B	76	0000
	3C	78	0001

Table 4-4. CFI Mode: Primary Vendor-Specific Extended Query Data Values

Description	Address (h) (Word Mode)	Address (h) (Byte Mode)	Data (h)
Query - Primary extended table, unique ASCII string, PRI	40	80	0050
	41	82	0052
	42	84	0049
Major version number, ASCII	43	86	0031
Minor version number, ASCII	44	88	0030
Unlock recognizes address (0= recognize, 1= don't recognize)	45	8A	0000
Erase suspend (2= to both read and program)	46	8C	0002
Sector protect (N= # of sectors/group)	47	8E	0001
Temporary sector unprotect (1=supported)	48	90	0001
Sector protect/Chip unprotect scheme	49	92	0004
Simultaneous R/W operation (0=not supported)	4A	94	0000
Burst mode (0=not supported)	4B	96	0000
Page mode (0=not supported)	4C	98	0000
Minimum acceleration supply (0= not supported), [D7:D4] for volt, [D3:D0] for 100mV	4D	9A	00A5
Maximum acceleration supply (0= not supported), [D7:D4] for volt, [D3:D0] for 100mV	4E	9C	00B5
Top/Bottom boot block indicator 02h=bottom boot device 03h=top boot device	4F	9E	0002/0003

ELECTRICAL CHARACTERISTICS**ABSOLUTE MAXIMUM STRESS RATINGS**

Surrounding Temperature with Bias		-65°C to +125°C
Storage Temperature		-65°C to +150°C
Voltage Range	VCC	-0.5V to +4.0 V
	RESET#, A9 and OE#	-0.5V to +10.5 V
	The other pins	-0.5V to Vcc +0.5V
Output Short Circuit Current (less than one second)		200 mA

Note:

1. Minimum voltage may undershoot to -2V during transition and for less than 20ns during transitions.
2. Maximum voltage may overshoot to Vcc+2V during transition and for less than 20ns during transitions.

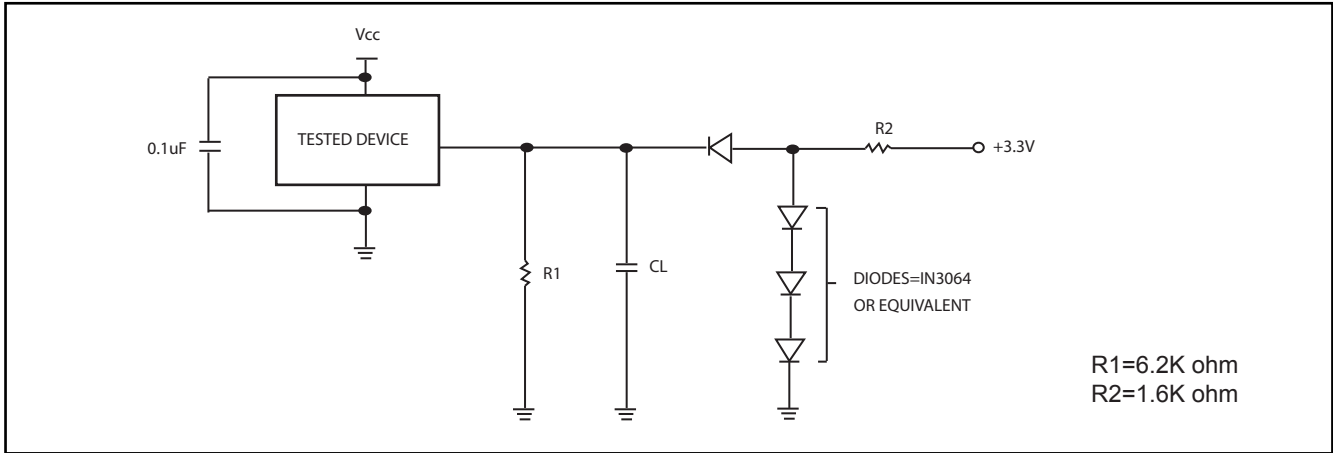
OPERATING TEMPERATURE AND VOLTAGE

Commercial (C) Grade	Surrounding Temperature (T _A)	0°C to +70°C
Industrial (I) Grade	Surrounding Temperature (T _A)	-40°C to +85°C
VCC Supply Voltages	VCC range	+2.7 V to 3.6 V

DC CHARACTERISTICS

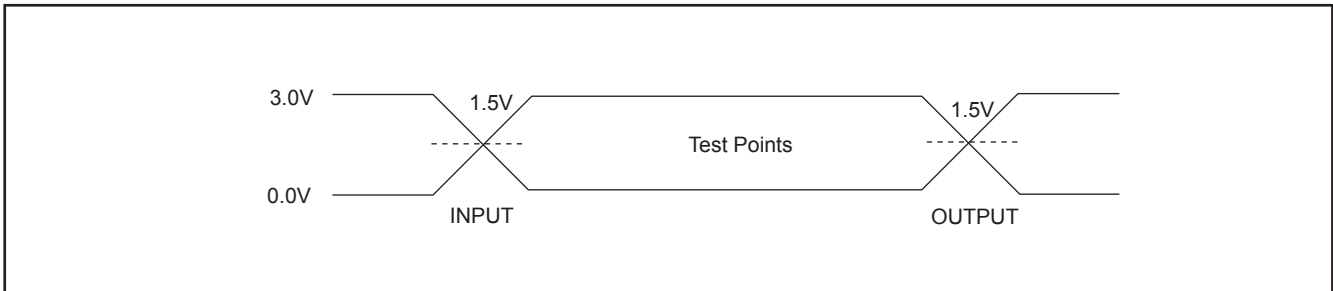
Symbol	Description	Min.	Typ.	Max.	Remark
Iilk	Input Leak			± 1.0uA	
Iilk9	A9 Leak			35uA	A9=10.5V
Iolk	Output Leak			± 1.0uA	
Icr1	Read Current(5MHz)		5mA	12mA	CE#=Vil, OE#=Vih
Icr2	Read Current(1MHz)		2mA	4mA	CE#=Vil, OE#=Vih
Icw	Write Current		15mA	30mA	CE#=Vil, OE#=Vih, WE#=Vil
I _{sb}	Standby Current		5uA	15uA	V _{cc} =V _{cc} max, other pins disable
I _{sr}	Reset Current		5uA	15uA	V _{cc} =V _{cc} max, Reset# enable, other pins disable
I _{sbs}	Sleep Mode Current		5uA	15uA	
I _{cp1}	Accelerated Pgm Current, WP#/Acc pin(Word/Byte)		5mA	10mA	CE#=Vil, OE#=Vih
I _{cp2}	Accelerated Pgm Current, Vcc pin,(Word/Byte)		15mA	30mA	CE#=Vil, OE#=Vih
Vil	Input Low Voltage	-0.5V		0.8V	
Vih	Input High Voltage	0.7xV _{cc}		V _{cc} +0.3V	
V _{hv}	Very High Voltage for hardware Protect/Unprotect/Accelerated Program/Auto Select/Temporary Unprotect	9.5V		10.5V	
V _{ol}	Output Low Voltage			0.45V	I _{ol} =4.0mA
V _{oh1}	Output High Voltage	0.85xV _{cc}			I _{oh1} =-2mA
V _{oh2}	Output High Voltage	V _{cc} -0.4V			I _{oh2} =-100uA
V _{lko}	Low Vcc Lock-out Voltage	2.3V		2.5V	

SWITCHING TEST CIRCUIT



Test Condition
 Output Load : 1 TTL gate
 Output Load Capacitance, CL : 30pF(70ns)/100pF(90ns)
 Rise/Fall Times : 5ns
 In/Out reference levels : 1.5V

SWITCHING TEST WAVEFORM



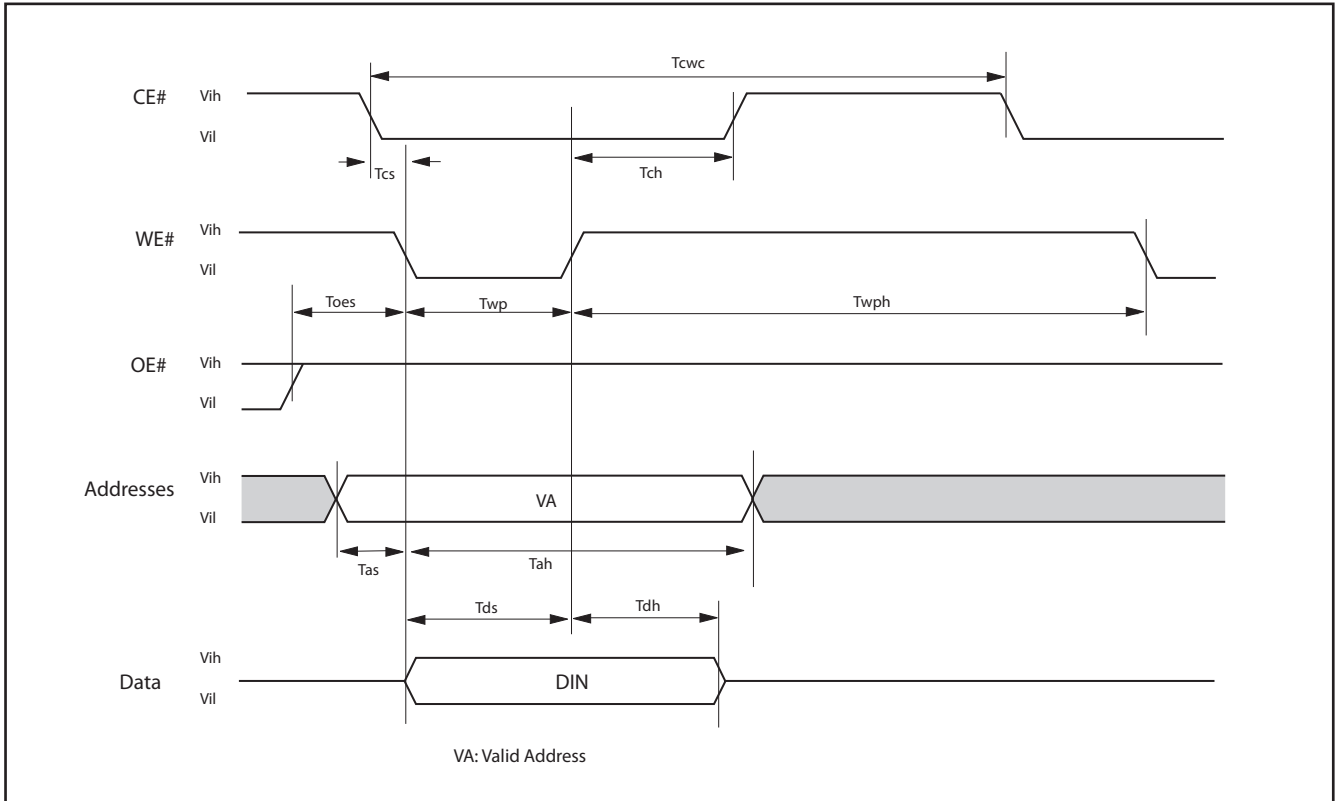
AC CHARACTERISTICS

Symbol	Description	Min.	Typ.	Max.	Unit
Taa	Valid data output after address			70	ns
Tce	Valid data output after CE# low			70	ns
Toe	Valid data output after OE# low			30	ns
Tdf	Data output floating after OE# high or CE# high			30	ns
Toh	Output hold time from the earliest rising edge of address, CE#, OE#	0			ns
Trc	Read period time	70			ns
Tsrw	Latency Between Read and Write Operation (*Note 1)	45			ns
Twc	Write period time	70			ns
Tcwc	Command write period time	70			ns
Tas	Address setup time	0			ns
Tah	Address hold time	45			ns
Tds	Data setup time	35			ns
Tdh	Data hold time	0			ns
Tvcs	Vcc setup time	200			us
Tcs	Chip enable Setup time	0			ns
Tch	Chip enable hold time	0			ns
Toes	Output enable setup time	0			ns
Toeh	Output enable hold time	Read	0		ns
Toeh		Toggle & Data# Polling	10		ns
Tws	WE# setup time	0			ns
Twh	WE# hold time	0			ns
Tcep	CE# pulse width	35			ns
Tceph	CE# pulse width high	30			ns
Twp	WE# pulse width	35			ns
Twph	WE# pulse width high	30			ns
Tbusy	Program/Erase active time by RY/BY#			90	ns
Tghwl	Read recover time before write	0			ns
Tghel	Read recover time before write	0			ns
Twhwh1	Program operation	Byte	9	300	us
Twhwh1	Program operation	Word	11	360	us
Twhwh1	Accelerated program operation		7	210	us
Twhwh2	Sector Erase Operation		0.7	2	sec
Tbal	Sector Add hold time			50	us

* Note 1: Sampled only, not 100% tested.

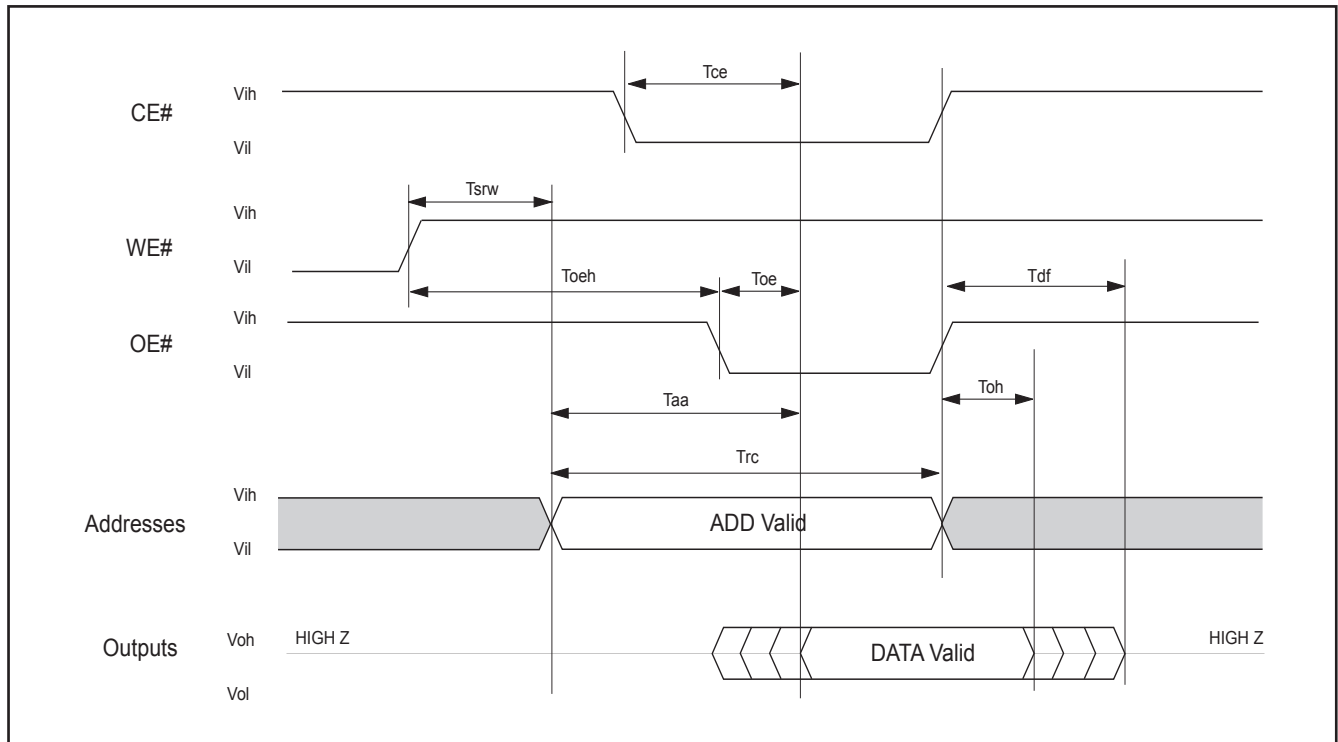
WRITE COMMAND OPERATION

Figure 1. COMMAND WRITE OPERATION



READ/RESET OPERATION

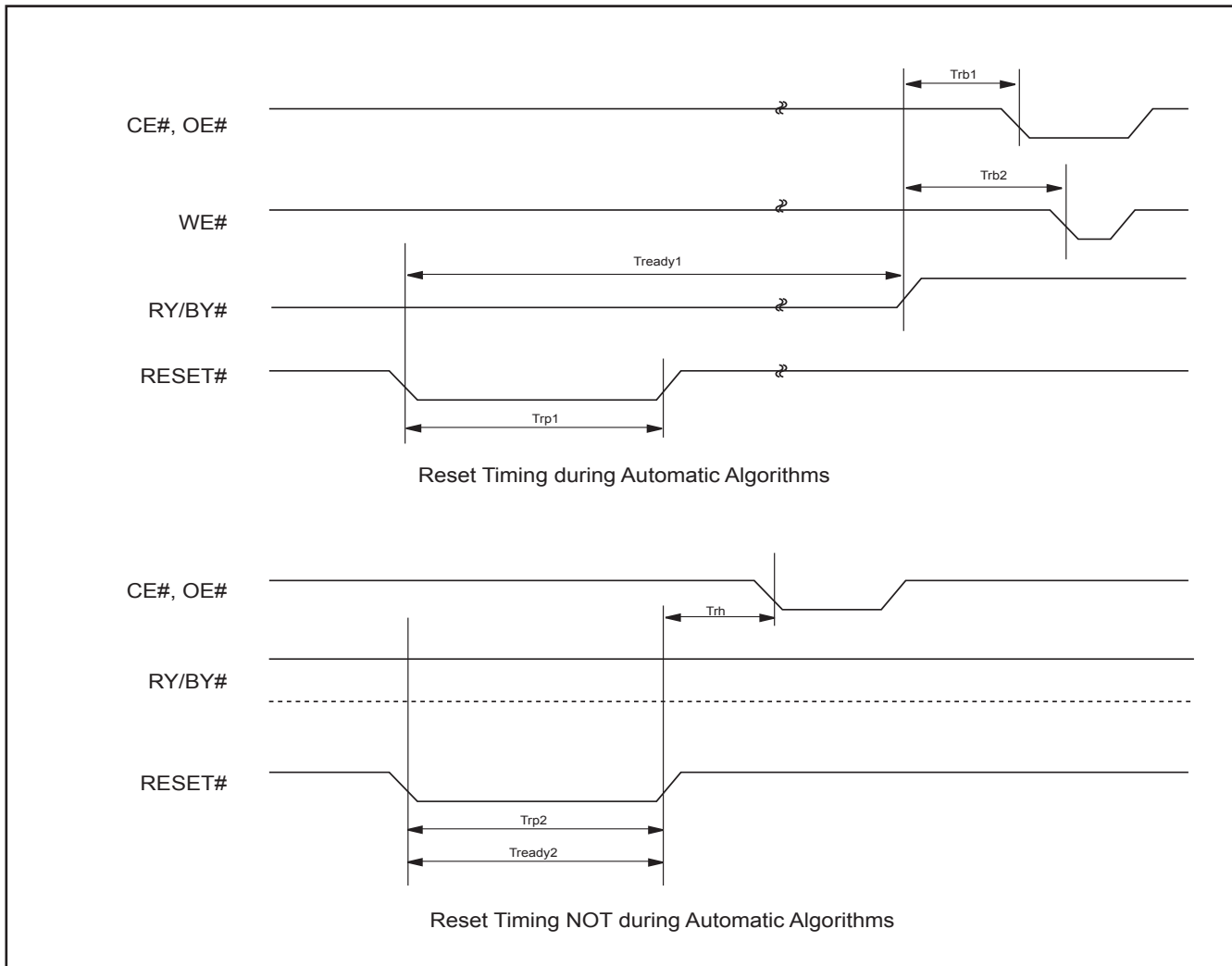
Figure 2. READ TIMING WAVEFORM



AC CHARACTERISTICS

Item	Description	Setup	Speed	Unit
Trp1	RESET# Pulse Width (During Automatic Algorithms)	MIN	10	us
Trp2	RESET# Pulse Width (NOT During Automatic Algorithms)	MIN	500	ns
Trh	RESET# High Time Before Read	MIN	70	ns
Trb1	RY/BY# Recovery Time (to CE#, OE# go low)	MIN	0	ns
Trb2	RY/BY# Recovery Time (to WE# go low)	MIN	50	ns
Tready1	RESET# PIN Low (During Automatic Algorithms) to Read or Write	MAX	20	us
Tready2	RESET# PIN Low (NOT During Automatic Algorithms) to Read or Write	MAX	500	ns

Figure 3. RESET# TIMING WAVEFORM



ERASE/PROGRAM OPERATION

Figure 4. AUTOMATIC CHIP ERASE TIMING WAVEFORM

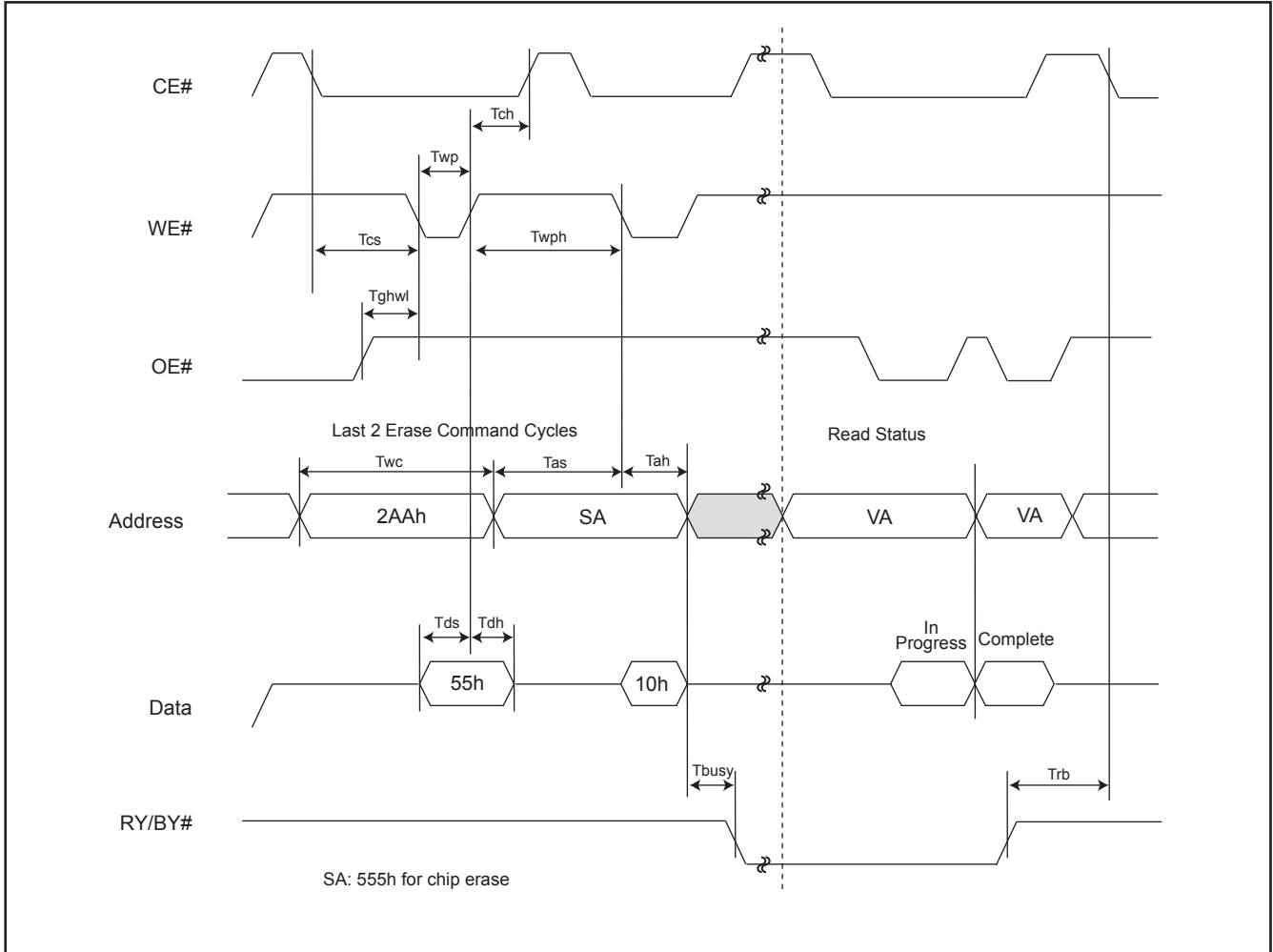


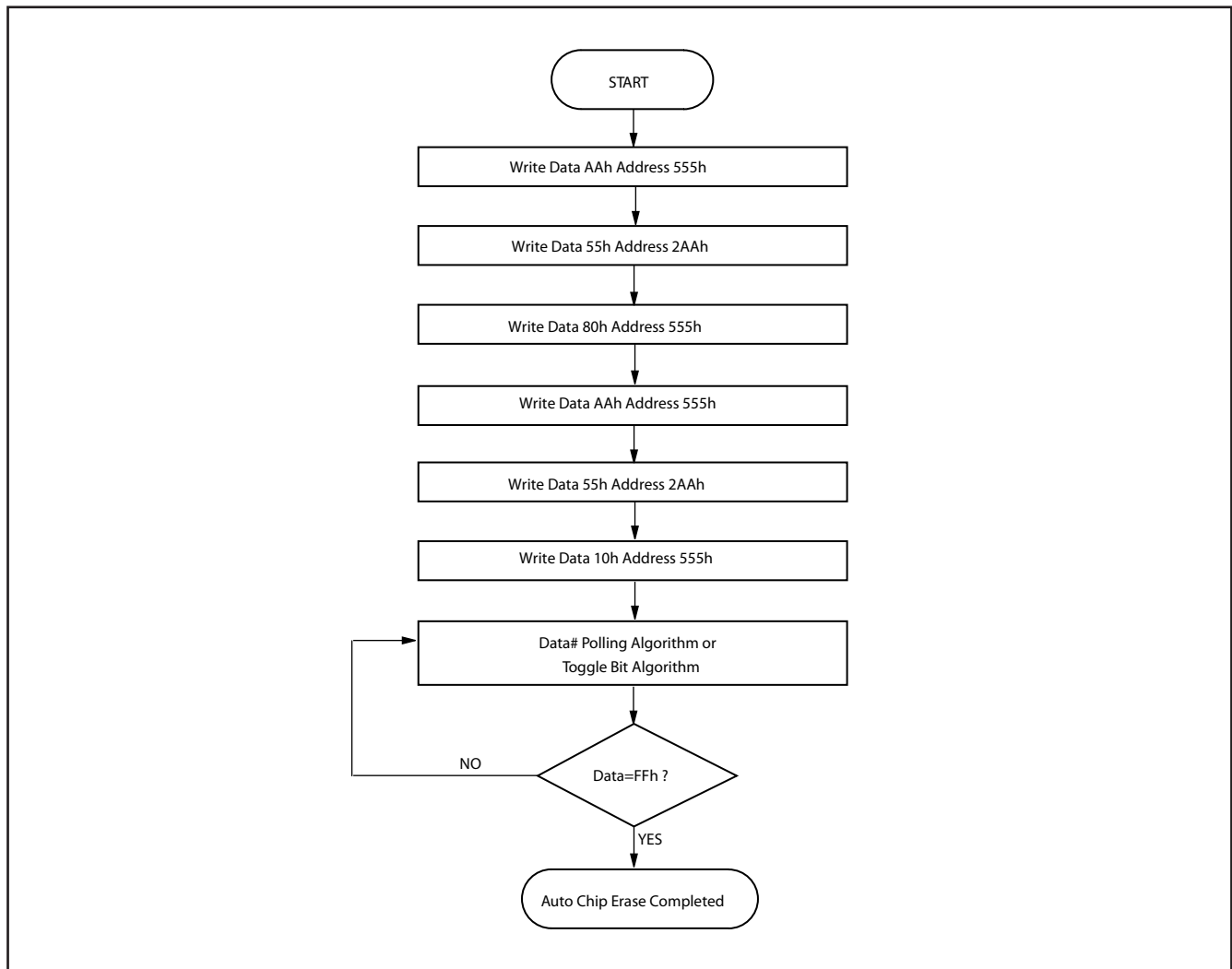
Figure 5. AUTOMATIC CHIP ERASE ALGORITHM FLOWCHART

Figure 6. AUTOMATIC SECTOR ERASE TIMING WAVEFORM

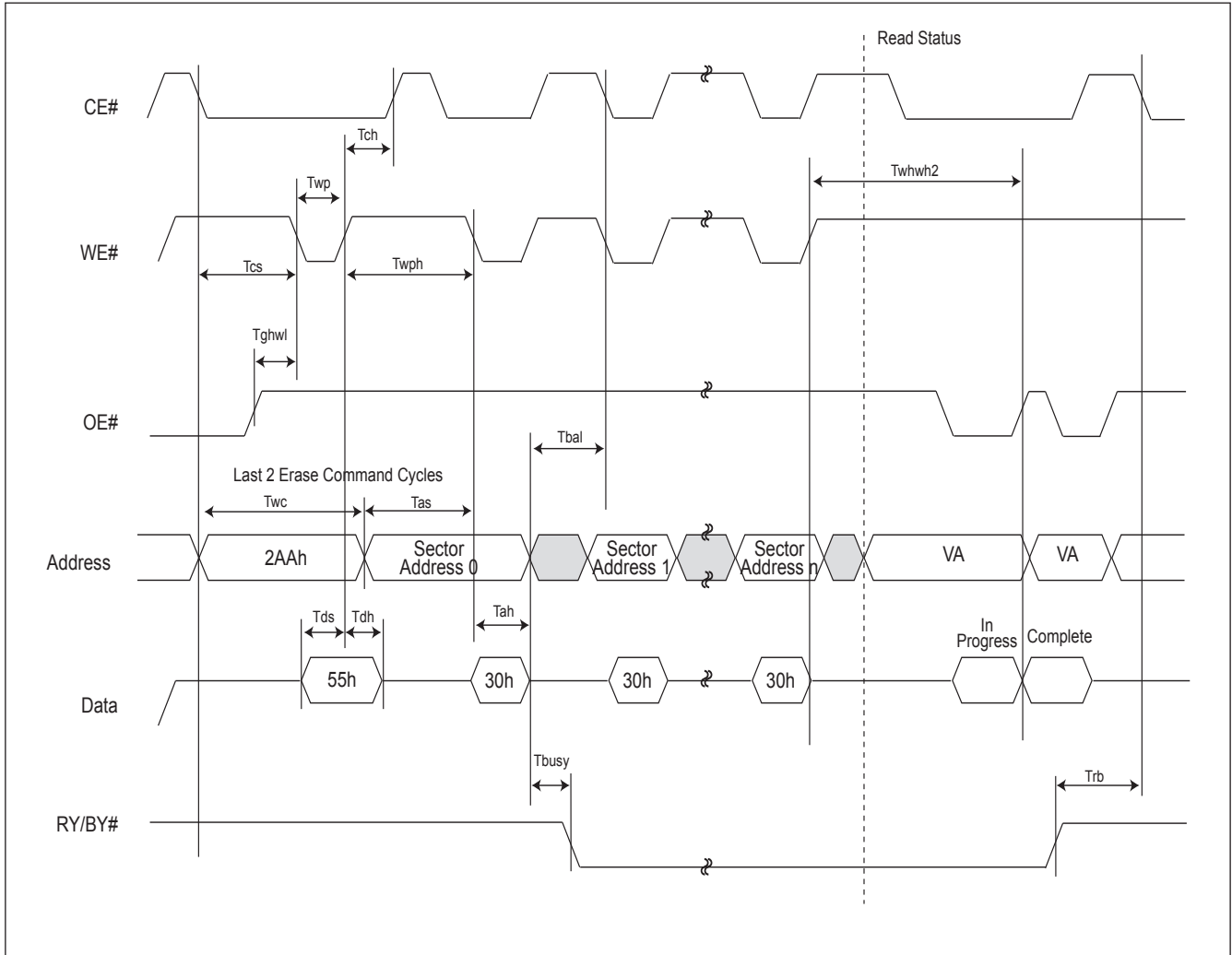


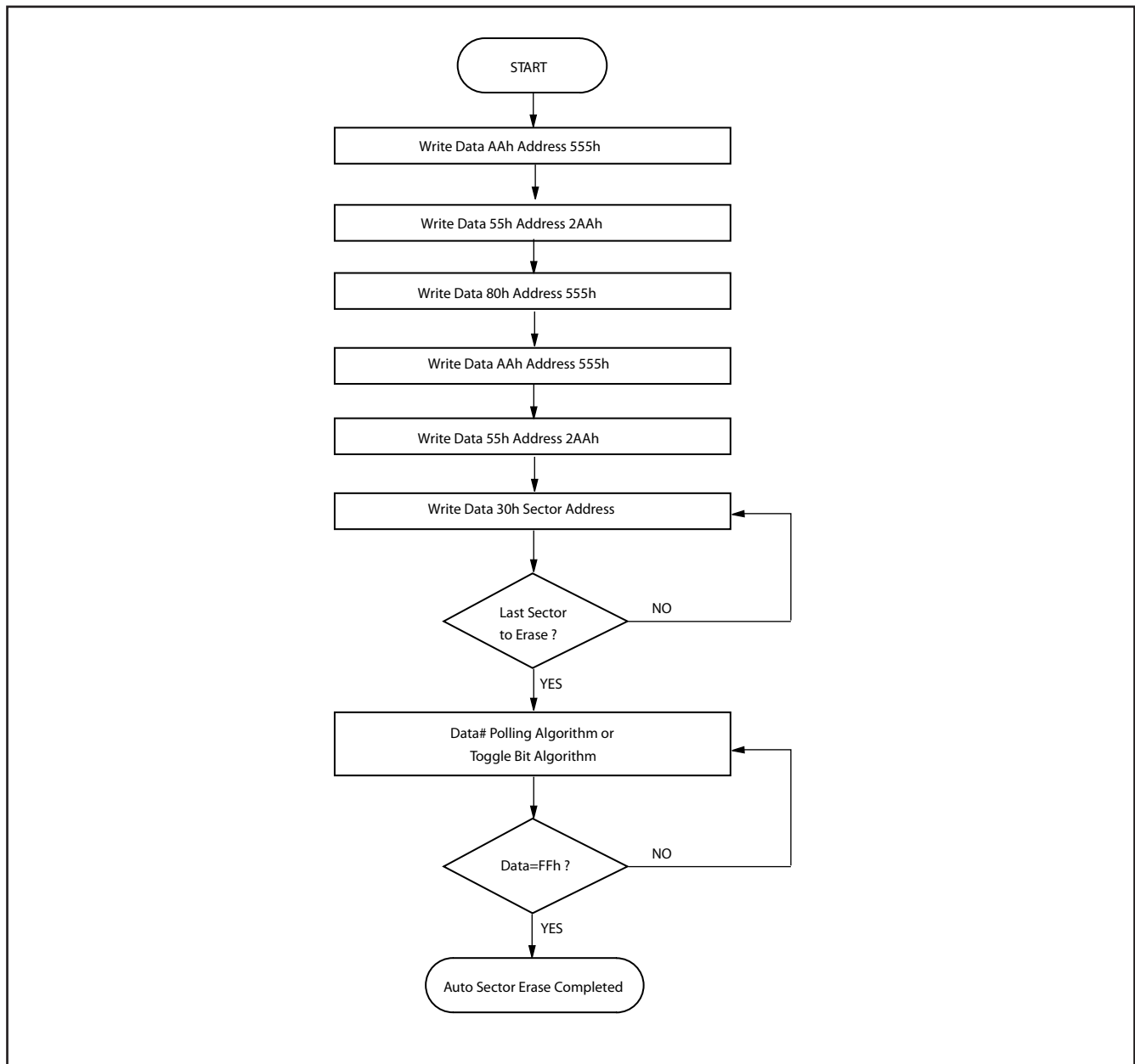
Figure 7. AUTOMATIC SECTOR ERASE ALGORITHM FLOWCHART

Figure 8. ERASE SUSPEND/RESUME FLOWCHART

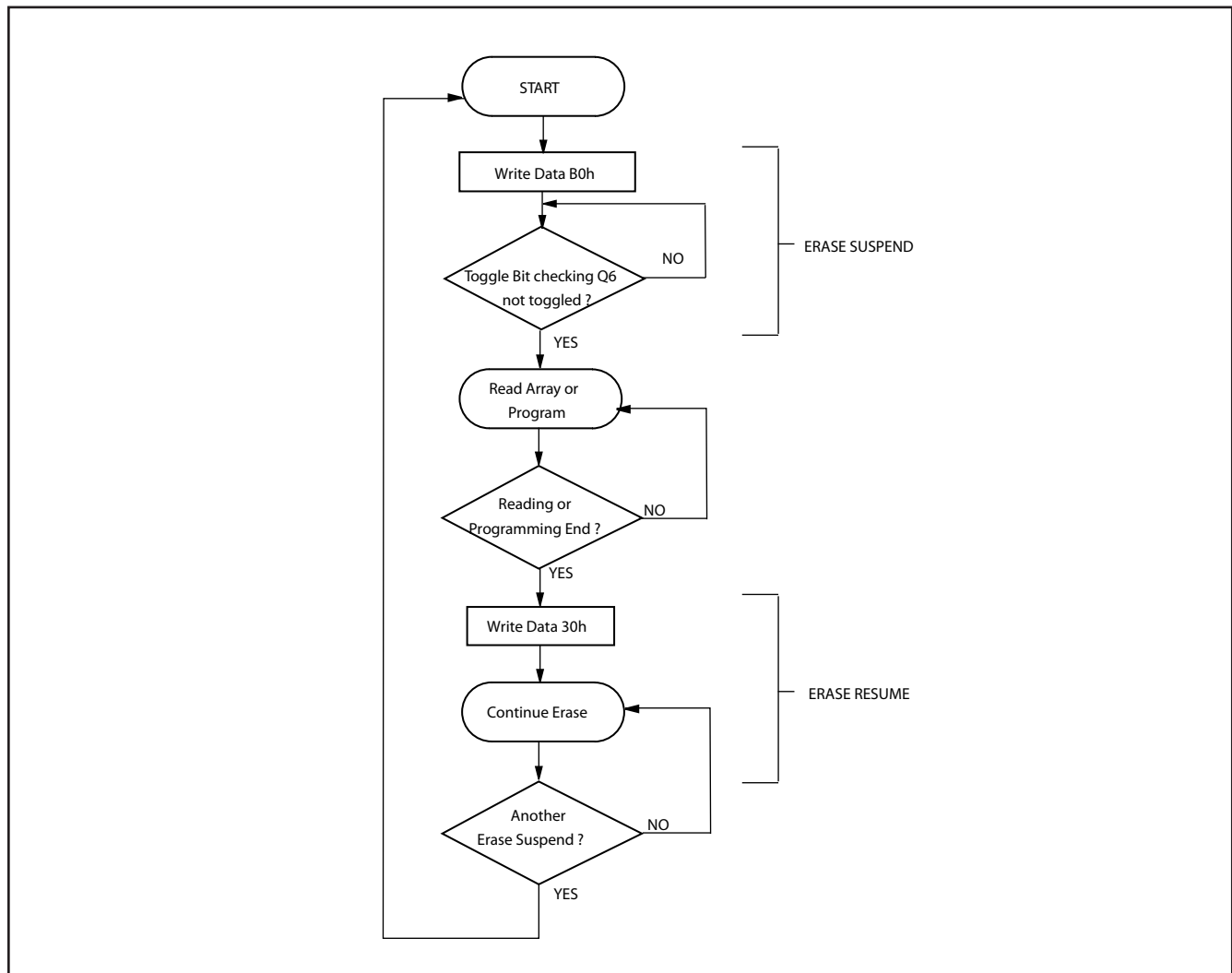


Figure 9. AUTOMATIC PROGRAM TIMING WAVEFORM

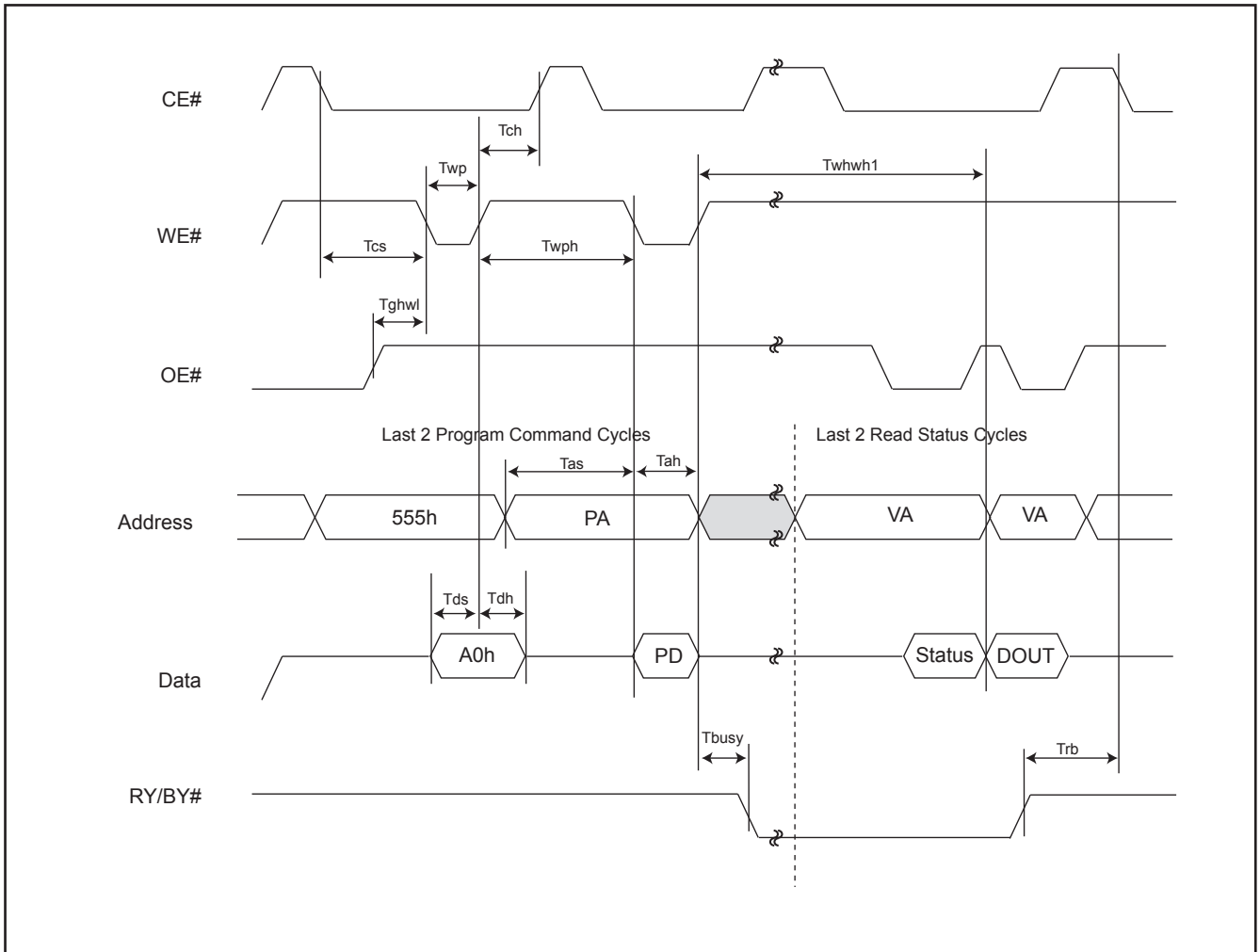


Figure 10. ACCELERATED PROGRAM TIMING DIAGRAM

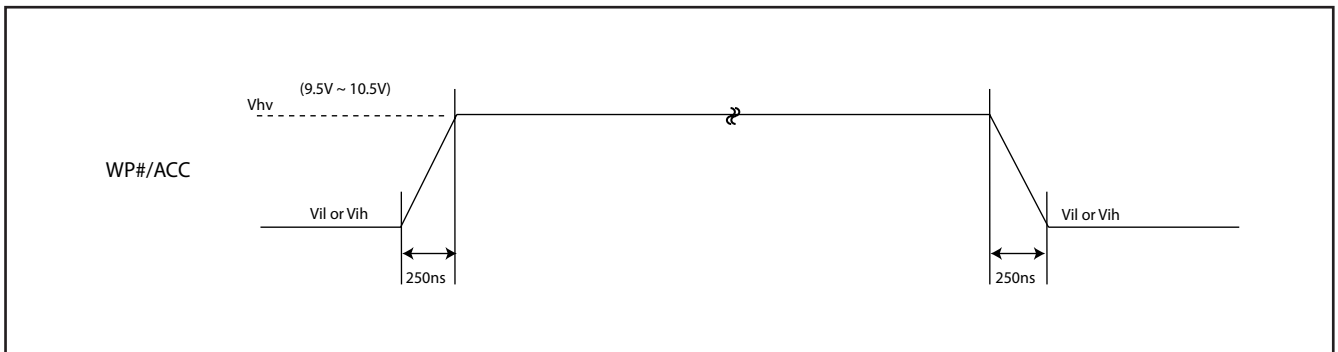


Figure 11. CE# CONTROLLED WRITE TIMING WAVEFORM

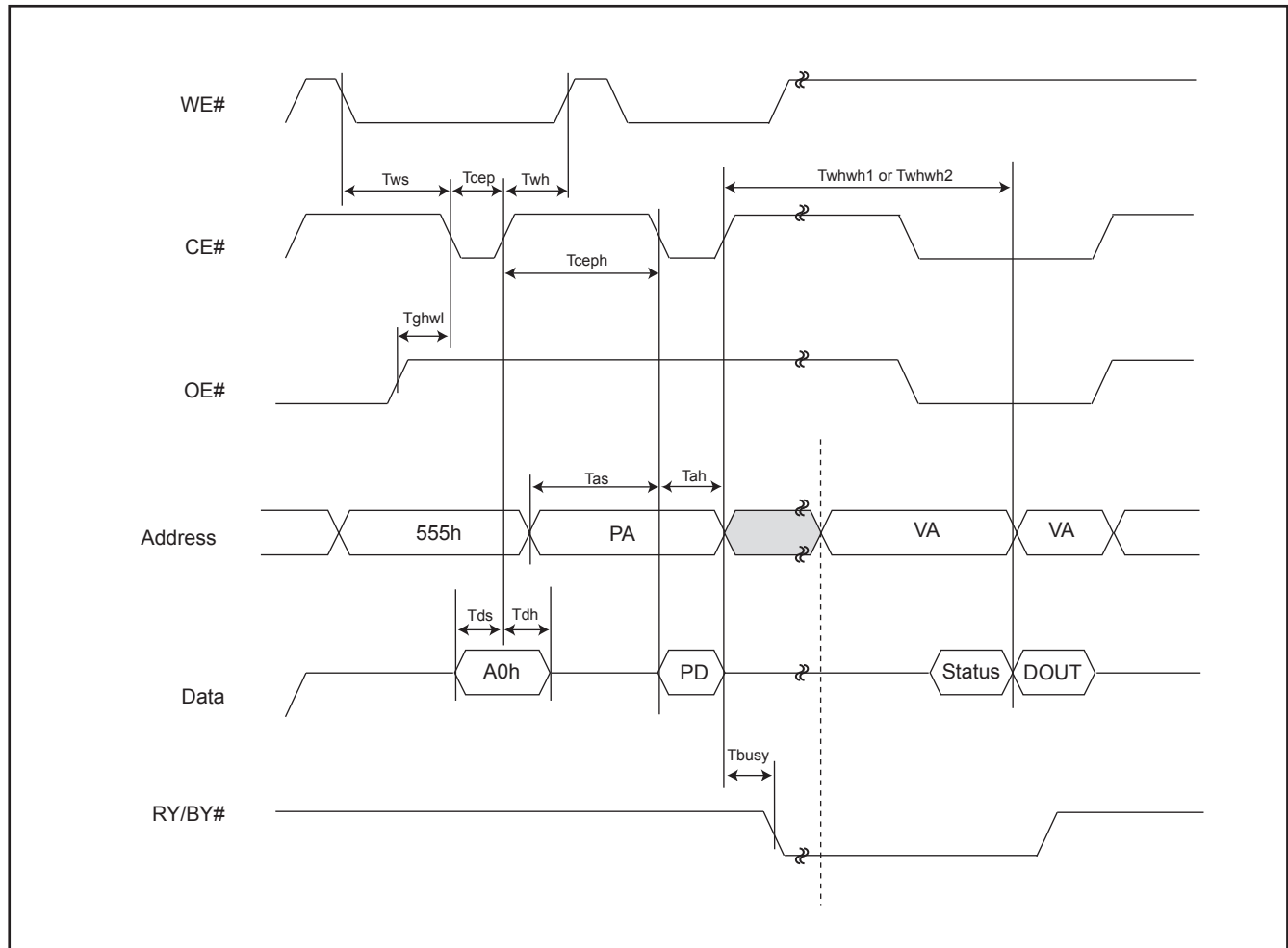
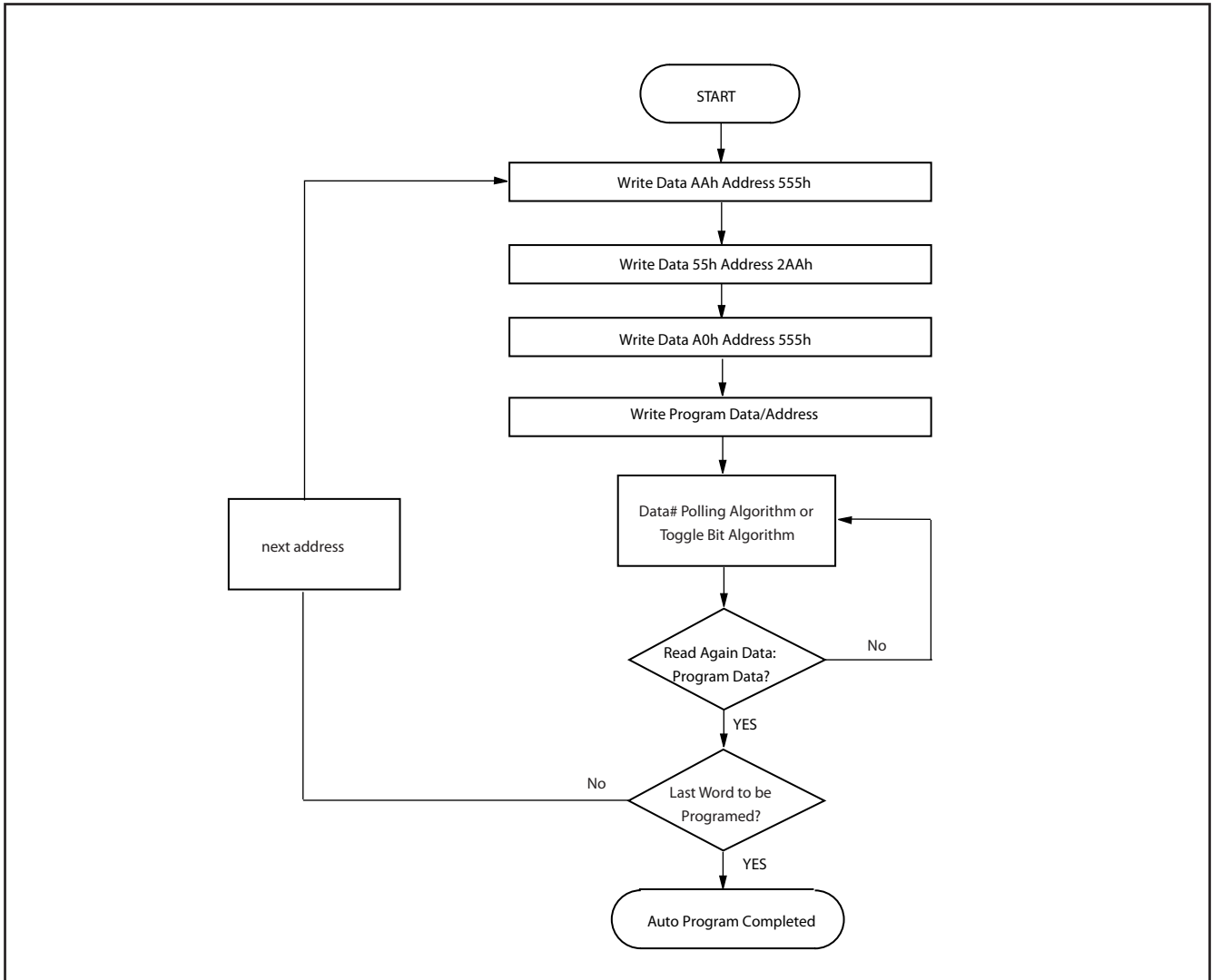


Figure 12. AUTOMATIC PROGRAMMING ALGORITHM FLOWCHART



SECTOR PROTECT/CHIP UNPROTECT

Figure 13. SECTOR PROTECT/CHIP UNPROTECT WAVEFORM (RESET# Control)

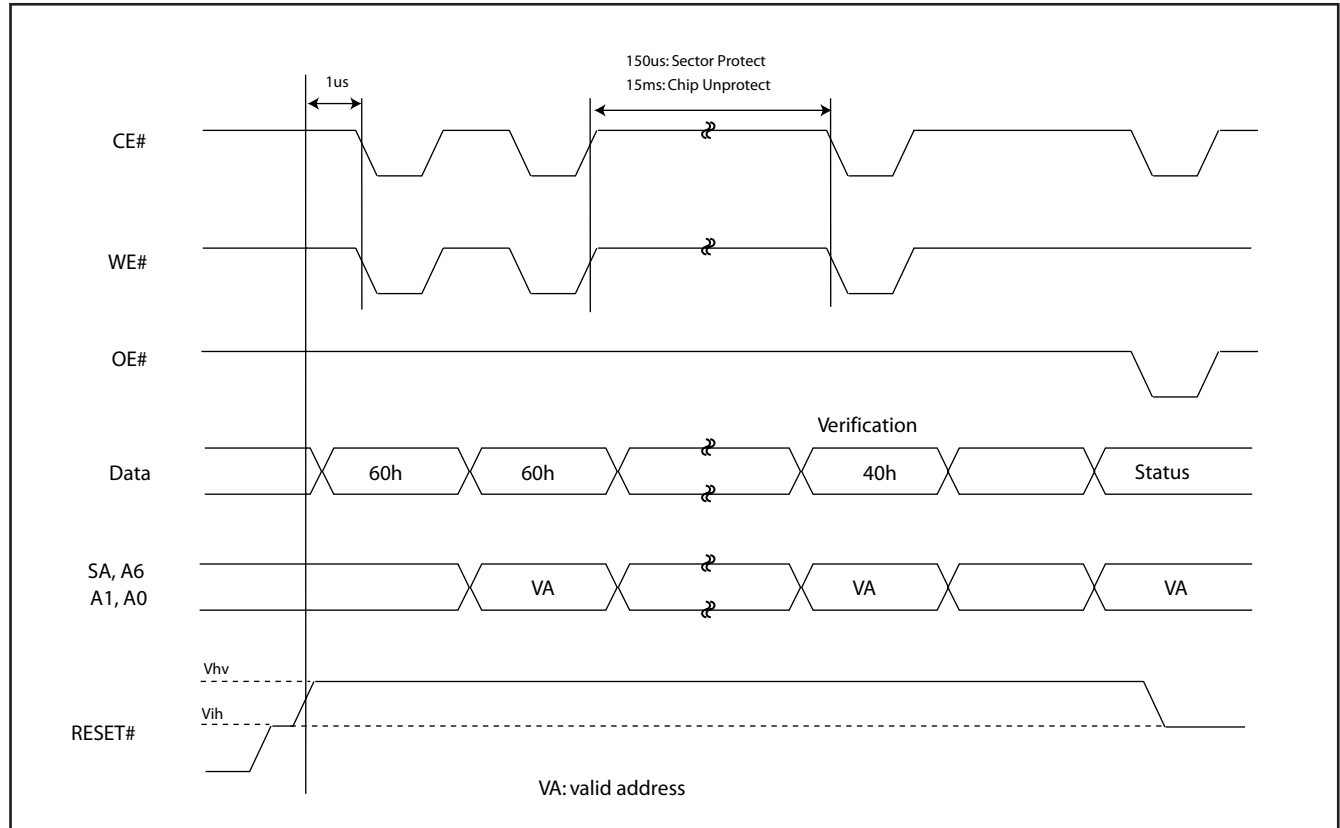


Figure 14. IN-SYSTEM SECTOR PROTECT WITH RESET#=Vhv

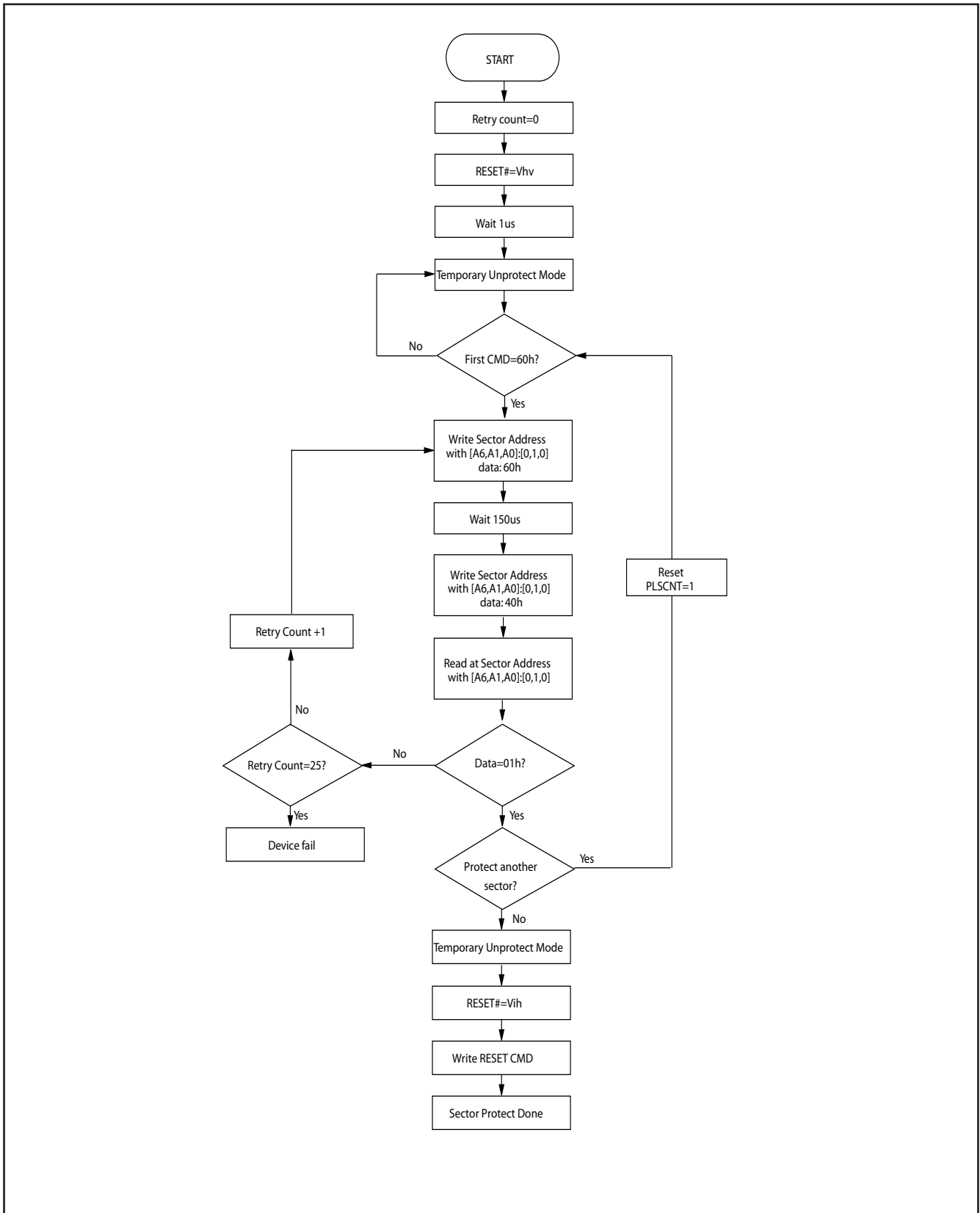


Figure 15. CHIP UNPROTECT ALGORITHMS WITH RESET#=Vhv

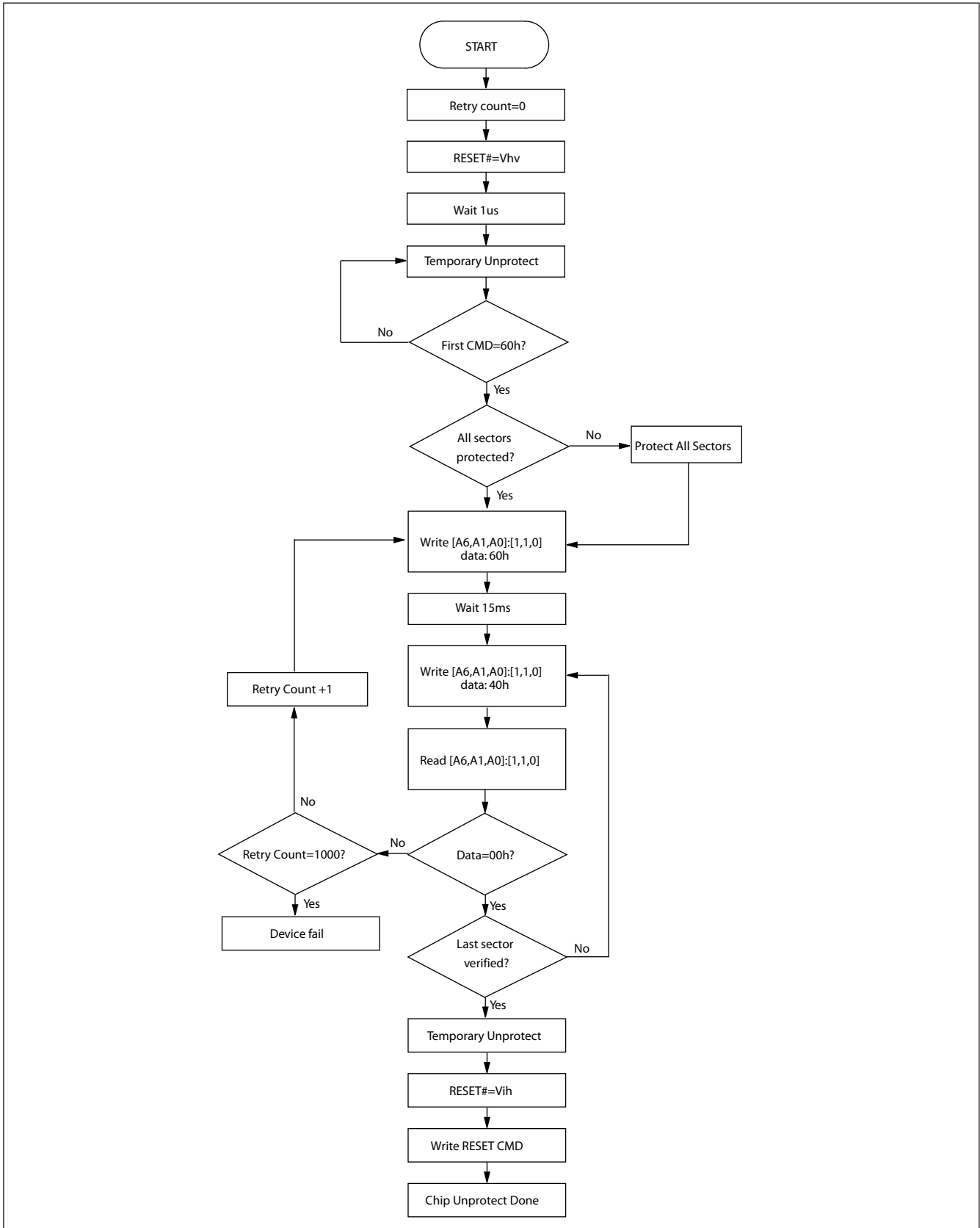


Table 5. TEMPORARY SECTOR UNPROTECT

Parameter	Alt	Description	Condition	Speed	Unit
Trpvhh	Tvidr	RESET# Rise Time to Vhv and Vhv Fall Time to RESET#	MIN	500	ns
Tvhhwl	Trsp	RESET# Vhv to WE# Low	MIN	4	us

Figure 16. TEMPORARY SECTOR UNPROTECT WAVEFORM

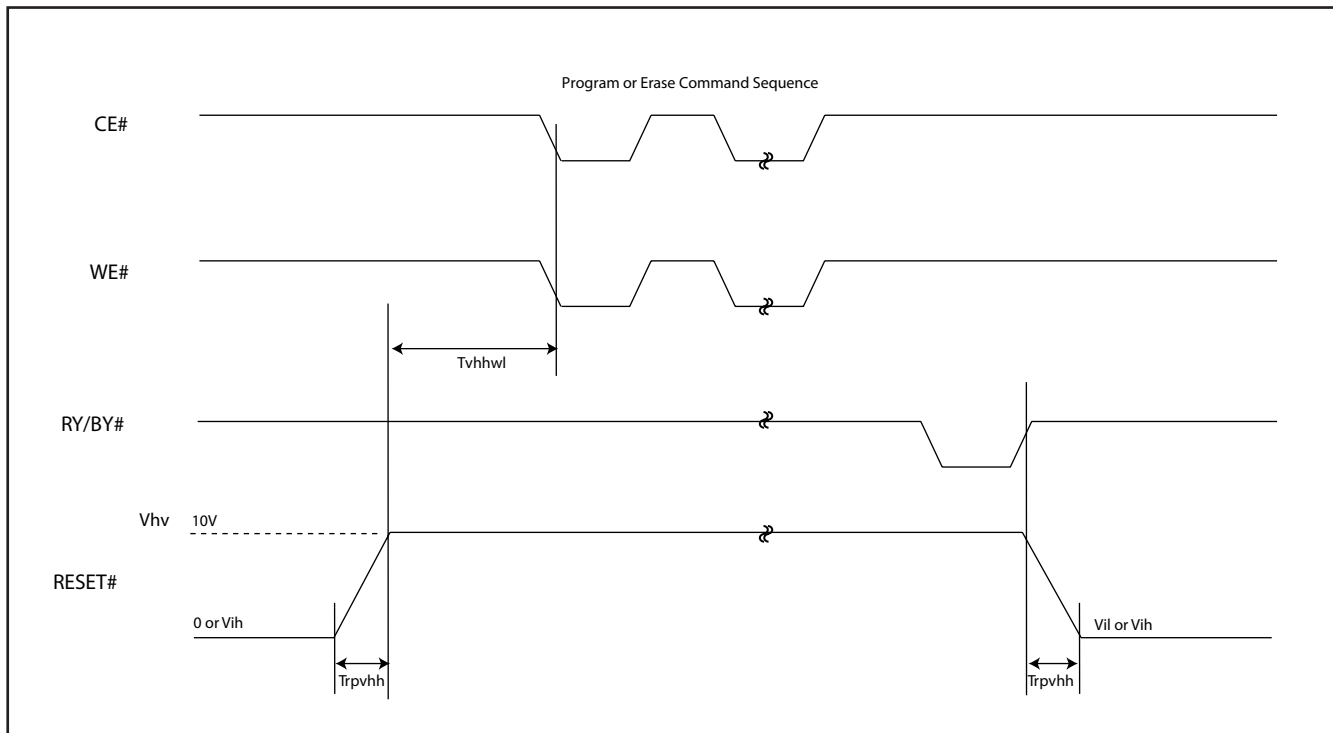
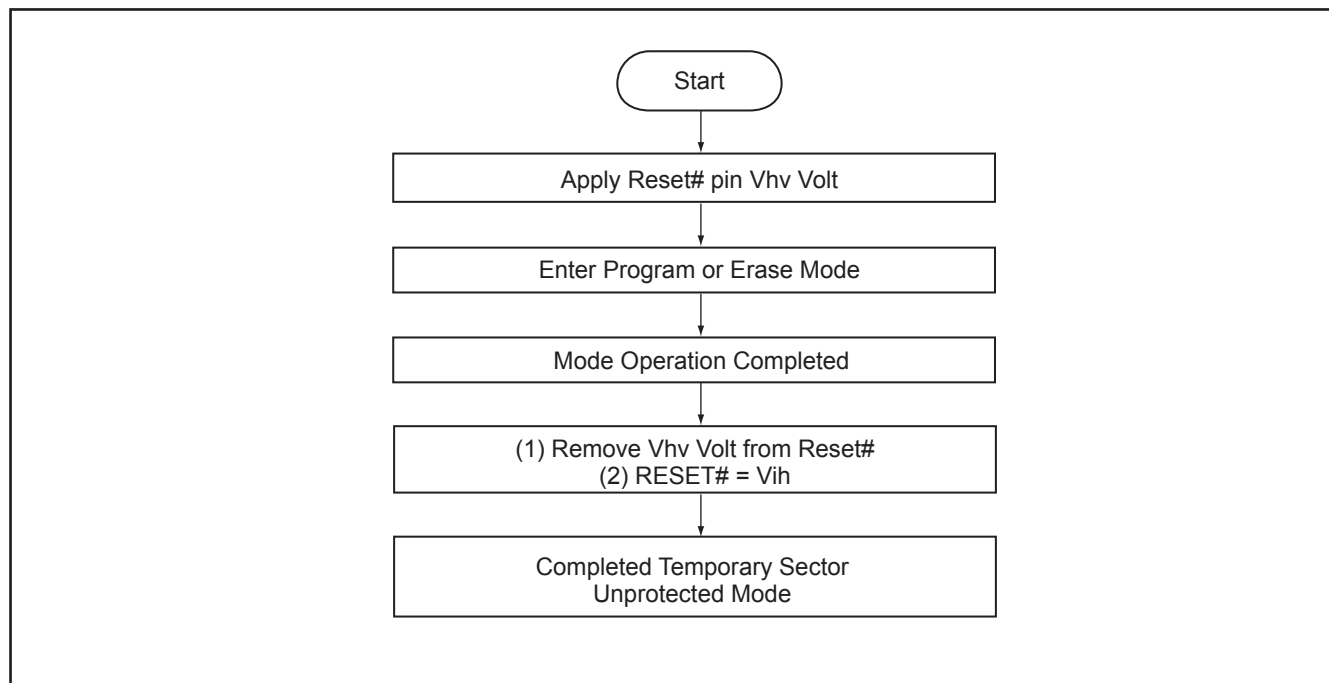
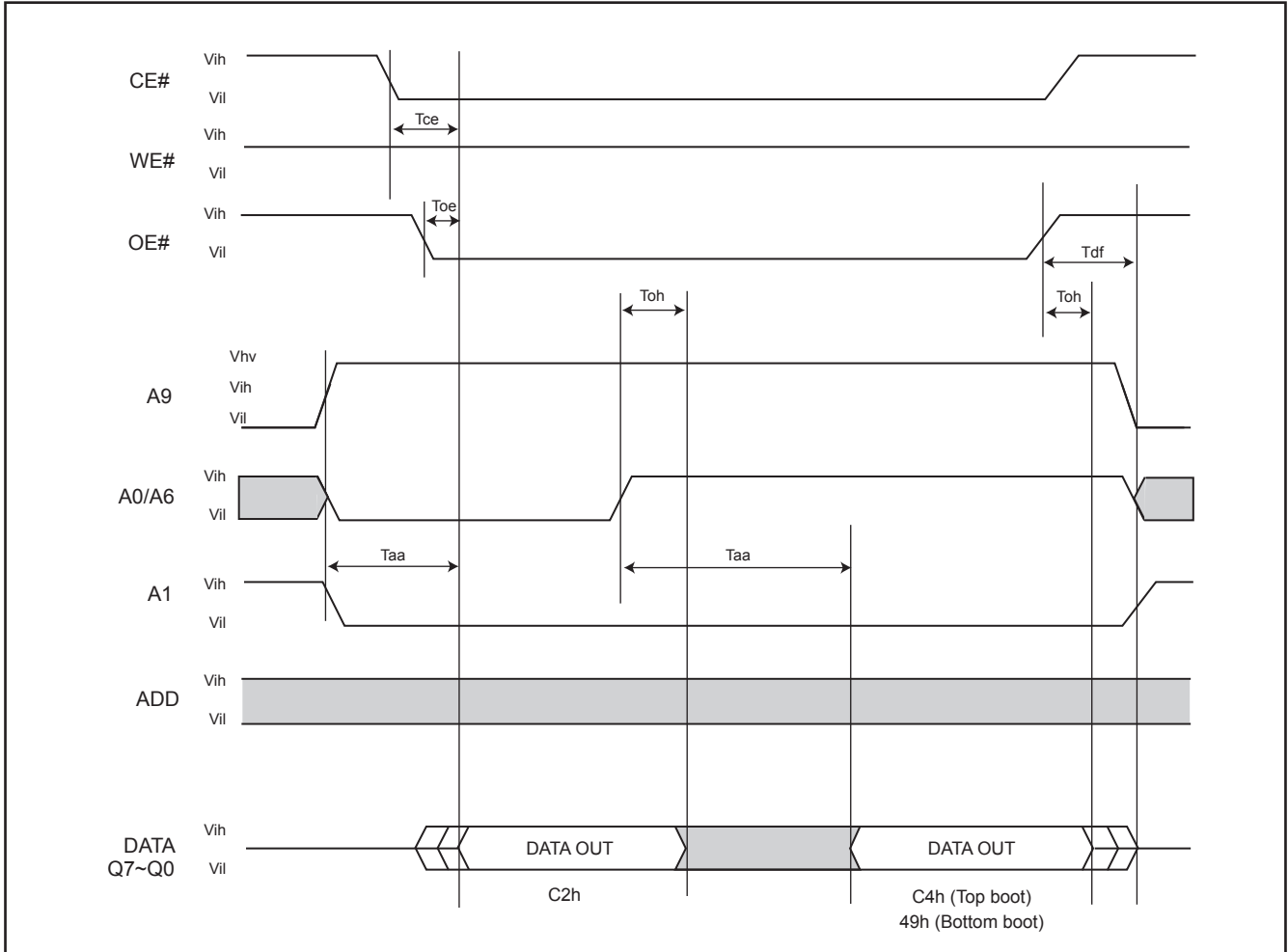


Figure 17. TEMPORARY SECTOR UNPROTECT FLOWCHART**Notes:**

1. Temporary unprotect all protected sectors $V_{hv}=9.5\sim 10.5V$.
2. After leaving temporary unprotect mode, the previously protected sectors are again protected.

Figure 18. SILICON ID READ TIMING WAVEFORM



WRITE OPERATION STATUS

Figure 19. DATA# POLLING TIMING WAVEFORM (DURING AUTOMATIC ALGORITHM)

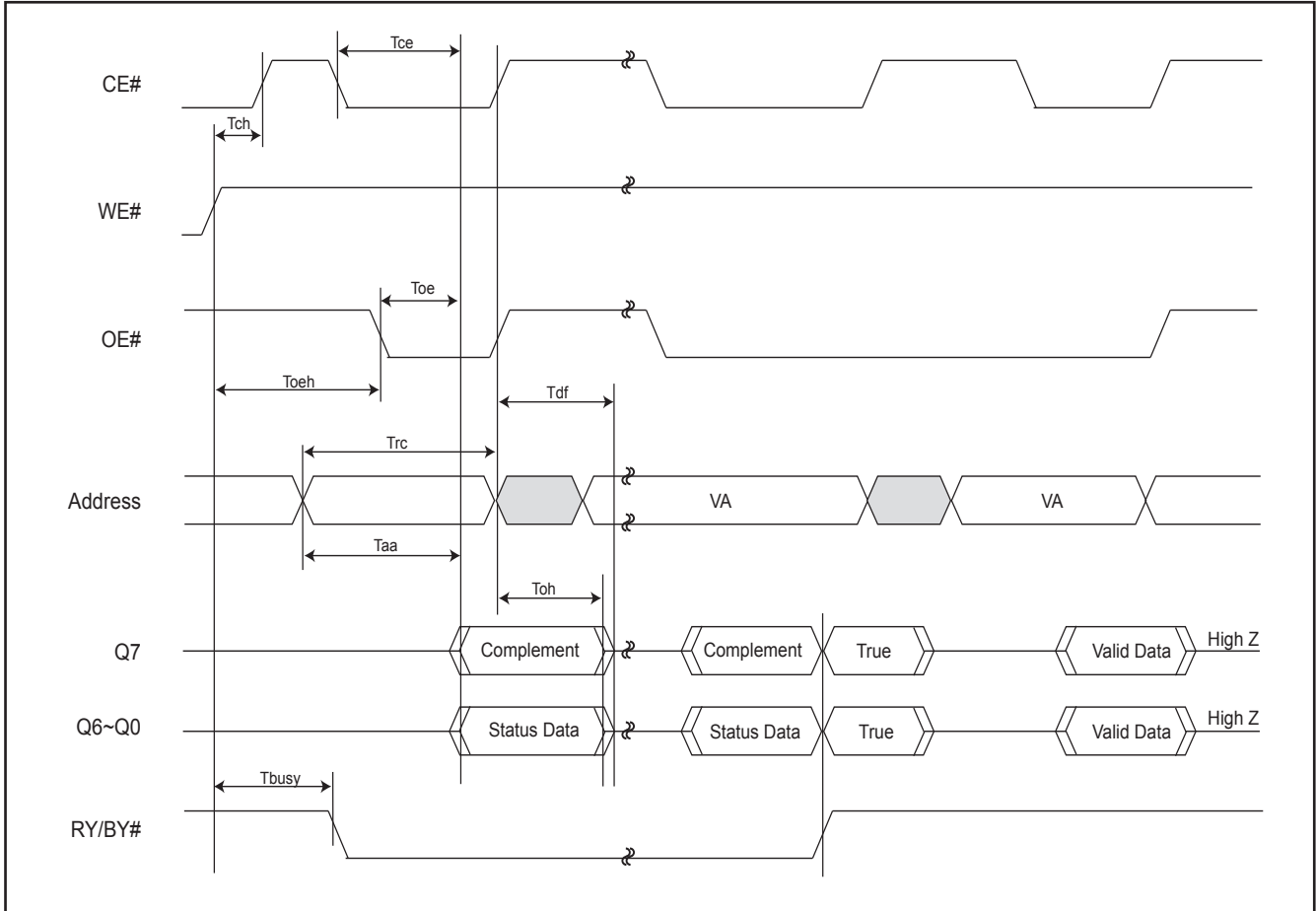
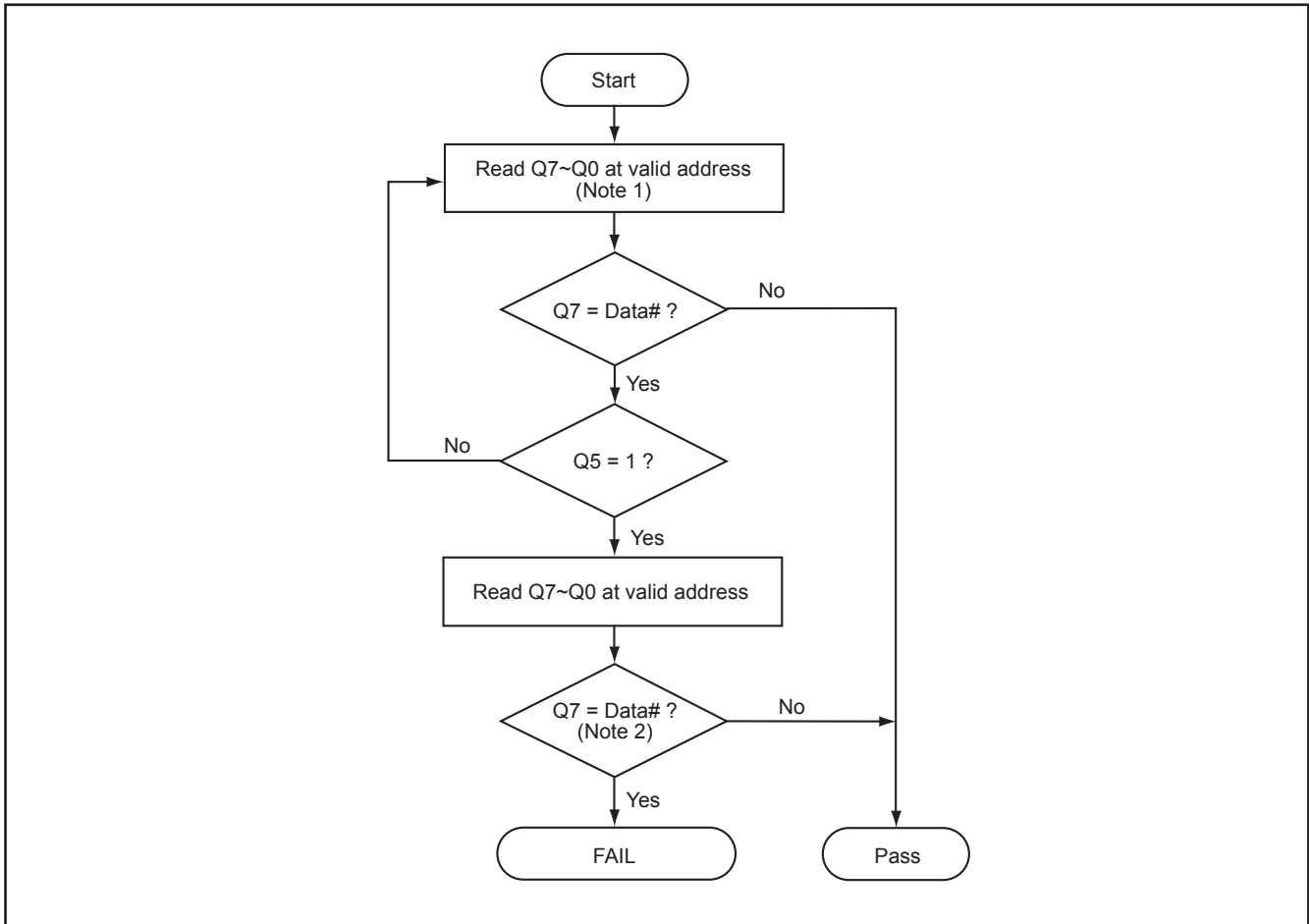


Figure 20. DATA# POLLING ALGORITHM**Notes:**

1. For programming, valid address means program address.
For erasing, valid address means erase sectors address.
2. Q7 should be rechecked even Q5="1" because Q7 may change simultaneously with Q5.

Figure 21. TOGGLE BIT TIMING WAVEFORM (DURING AUTOMATIC ALGORITHM)

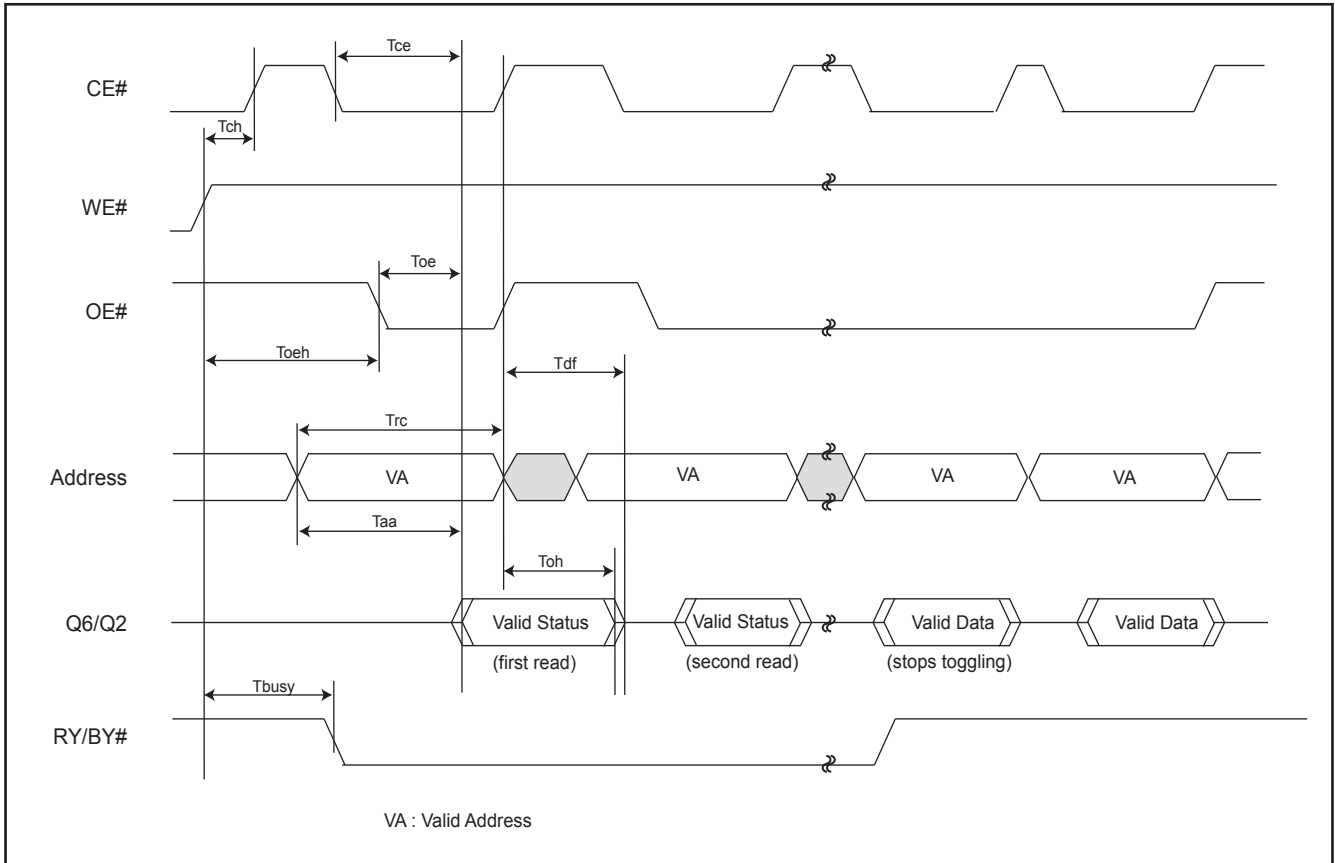
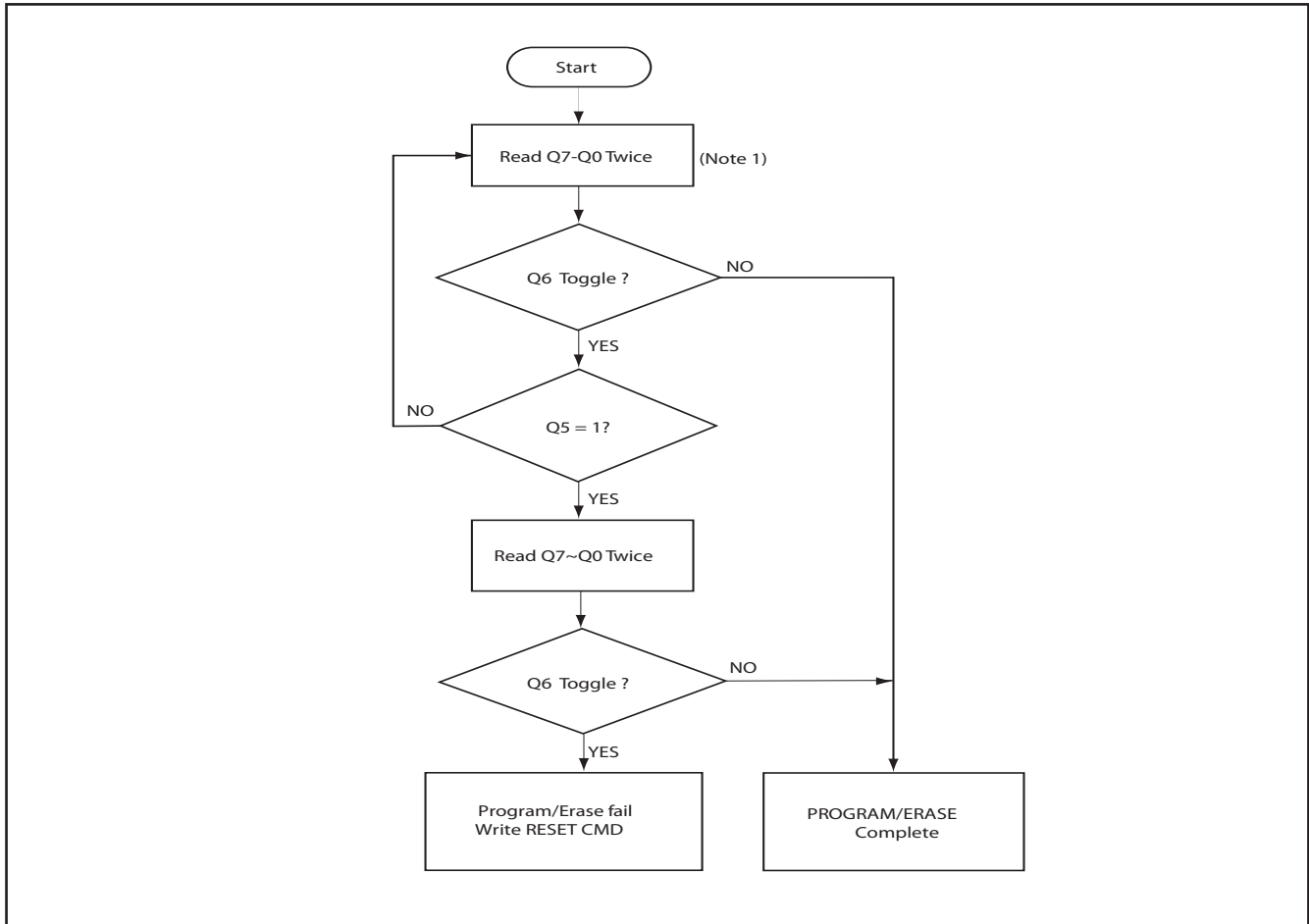


Figure 22. TOGGLE BIT ALGORITHM**Notes:**

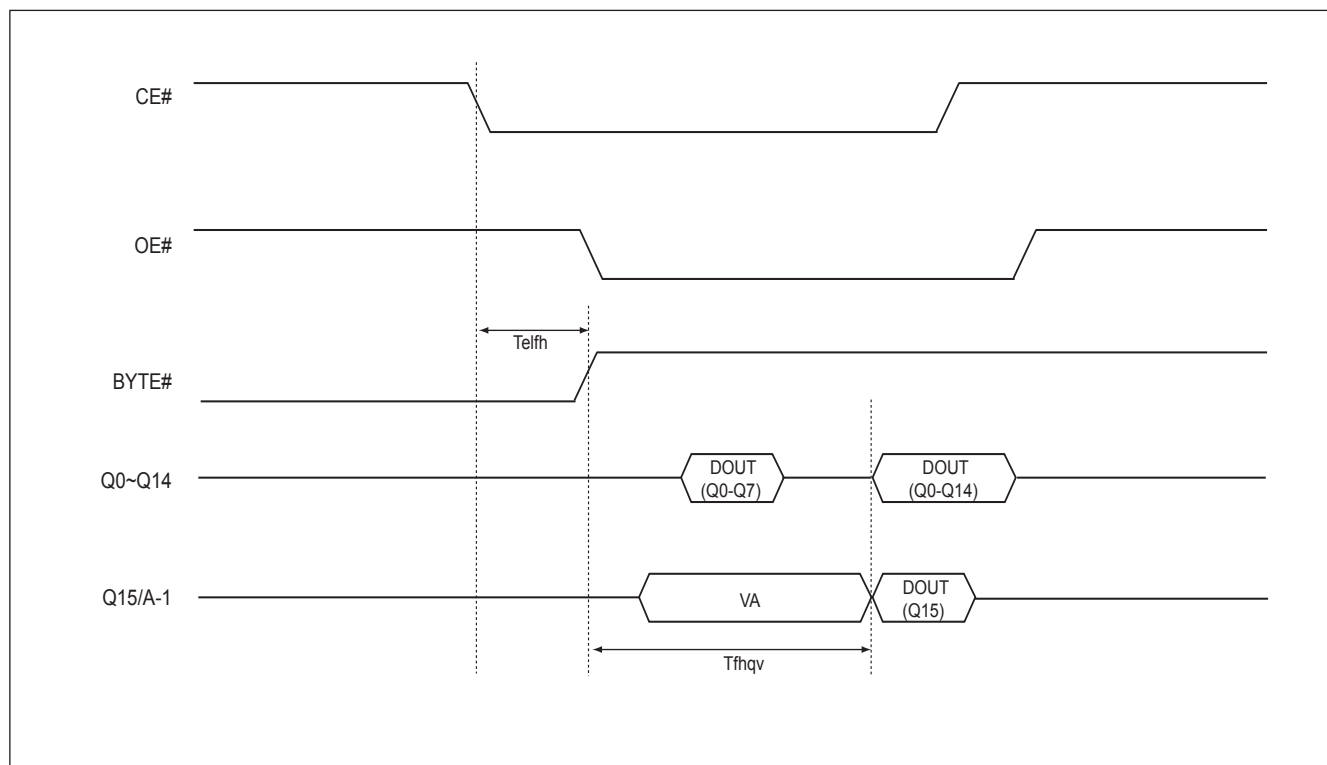
1. Read toggle bit twice to determine whether or not it is toggling.
2. Recheck toggle bit because it may stop toggling as Q5 changes to "1".

AC CHARACTERISTICS

WORD/BYTE CONFIGURATION (BYTE#)

Parameter	Description		Speed Options		Unit
			-70	-90	
Telfl/Telfh	CE# to BYTE# from L/H	MAX	5	5	ns
Tflqz	BYTE# from L to Output Hiz	MAX	25	30	ns
Tfhqv	BYTE# from H to Output Active	MIN	70	90	ns

Figure 23. BYTE# TIMING WAVEFORM FOR READ OPERATIONS (BYTE# switching from byte mode to word mode)



RECOMMENDED OPERATING CONDITIONS

At Device Power-Up

AC timing illustrated in Figure A is recommended for the supply voltages and the control signals at device power-up. If the timing in the figure is ignored, the device may not operate correctly.

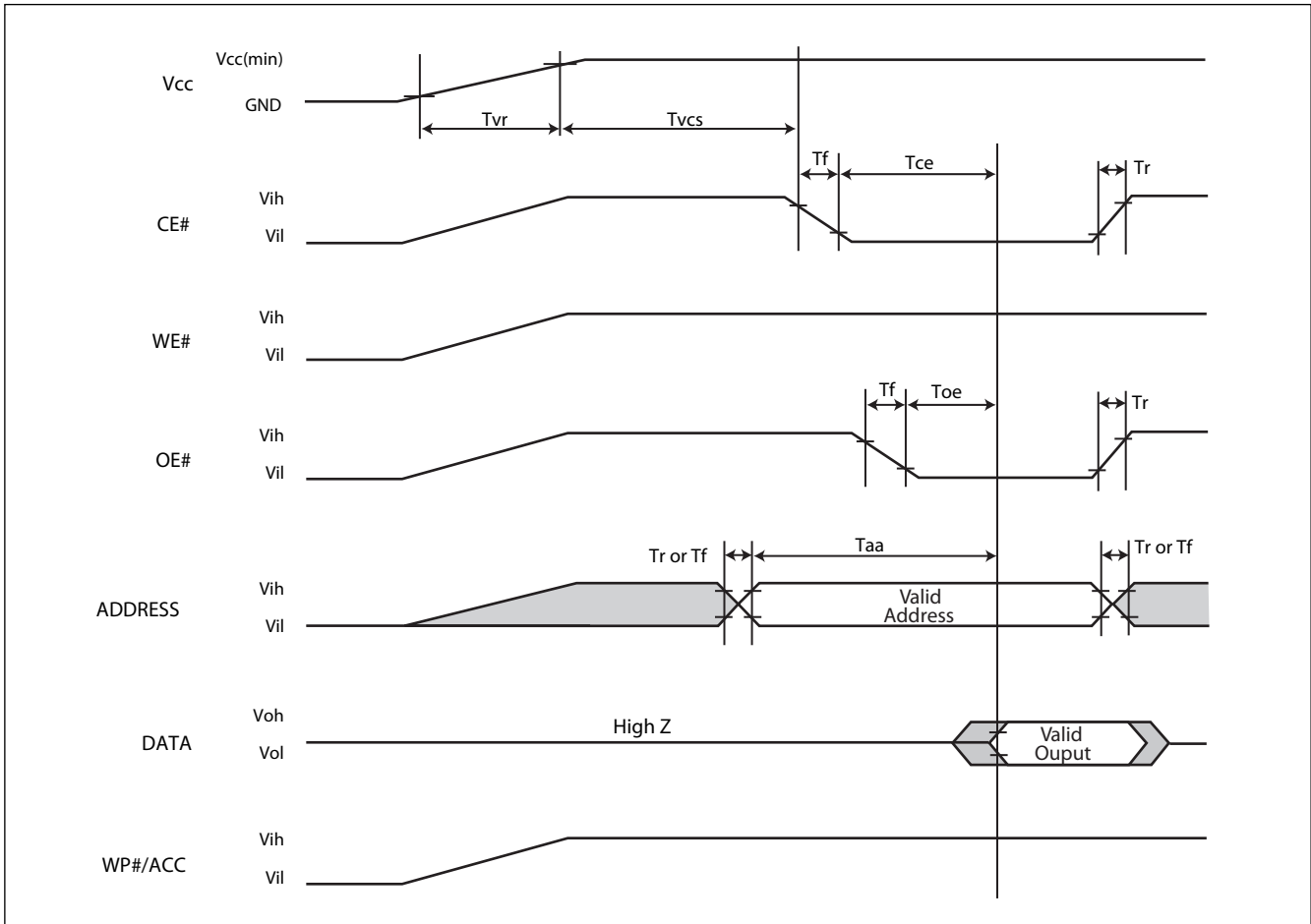


Figure A. AC Timing at Device Power-Up

Symbol	Parameter	Min.	Max.	Unit
Tvr	Vcc Rise Time	20	500000	us/V
Tr	Input Signal Rise Time		20	us/V
Tf	Input Signal Fall Time		20	us/V
Tvcs	Vcc Setup Time	200		us

ERASE AND PROGRAMMING PERFORMANCE

Parameter		Limits			Units
		Min.	Typ.	Max.	
Chip Erase Time			15	32	sec
Sector Erase Time			0.7	2	sec
Erase/Program Cycles			100,000		Cycles
Chip Programming Time	Byte Mode		18	54	sec
	Word Mode		12	36	sec
Word Program Time			11	360	us
Byte Programming Time			9	300	us
Accelerated Program Time			7	210	us

Notes:

1. Typical program and erase times assume the following conditions: 25°C, 3.0V VCC. Programming specifications assume checkboard data pattern.
2. Maximum values are measured at VCC = 3.0 V, worst case temperature. Maximum values are valid up to and including 100,000 program/erase cycles.
3. Word/Byte programming specification is based upon a single word/byte programming operation not utilizing the write buffer.
4. Erase/Program cycles comply with JEDEC JESD-47 & JESD 22-A117 standard.

DATA RETENTION

Parameter	Condition	Min.	Max.	Unit
Data retention	55°C	20		years

LATCH-UP CHARACTERISTICS

	Min.	Max.
Input voltage difference with GND on all pins except I/O pins	-1.0V	10.5V
Input voltage difference with GND on all I/O pins	-1.0V	1.5 x Vcc
Vcc Current	-100mA	+100mA

All pins included except Vcc. Test conditions: Vcc = 3.0V, one pin per testing

PIN CAPACITANCE

Parameter Symbol	Parameter Description	Test Set	Typ.	Max.	Unit
CIN2	Control Pin Capacitance	VIN=0	7.5	9	pF
COUT	Output Capacitance	VOUT=0	8.5	12	pF
CIN	Input Capacitance	VIN=0	6	7.5	pF



ORDERING INFORMATION

PART NO.	ACCESS TIME (ns)	Ball Pitch/ Ball Size	PACKAGE	Remark
MX29LV160DTTI-70G	70		48 Pin TSOP (Normal Type)	
MX29LV160DBTI-70G	70		48 Pin TSOP (Normal Type)	
MX29LV160DTXBI-70G	70	0.8mm/0.3mm	48 Ball CSP(TFBGA) (ball size:0.3mm)	
MX29LV160DBXBI-70G	70	0.8mm/0.3mm	48 Ball CSP(TFBGA) (ball size:0.3mm)	
MX29LV160DTGBI-70G	70		48 Ball XFLGA (4 x 6 x 0.5mm)	
MX29LV160DBGBI-70G	70		48 Ball XFLGA (4 x 6 x 0.5mm)	
MX29LV160DTXHI-70G	70		48 Ball WFBGA (4 x 6 x 0.75mm)	
MX29LV160DBXHI-70G	70		48 Ball WFBGA (4 x 6 x 0.75mm)	
MX29LV160DTXEI-70G	70	0.8mm/0.4mm	48 Ball LFBGA (ball size:0.4mm)	
MX29LV160DBXEI-70G	70	0.8mm/0.4mm	48 Ball LFBGA (ball size:0.4mm)	
MX29LV160DTXGI-70G*	70	0.8mm/0.4mm	48 Ball TFBGA (ball size: 0.4mm, height: 1.2mm)	
MX29LV160DBXGI-70G*	70	0.8mm/0.4mm	48 Ball TFBGA (ball size: 0.4mm, height: 1.2mm)	

* Advanced Information

PART NAME DESCRIPTION

MX 29 LV 160 D T T I - 70 G

OPTION:

G: RoHS Compliant package

SPEED:

70: 70ns

TEMPERATURE RANGE:

C: Commercial (0°C to 70°C)

I: Industrial (-40°C to 85°C)

PACKAGE:

T: TSOP

X: BGA

XB: TFBGA - 6 x 8 x 1.2mm, Pitch 0.8mm, 0.3mm Ball

XE: LFBGA - 6 x 8 x 1.3mm, Pitch 0.8mm, 0.4mm Ball

XH: WFBGA - 4 x 6 x 0.75mm, Pitch 0.5mm, 0.3mm Ball

XG: TFBGA - 6 x 8 x 1.2mm, Pitch 0.8mm, 0.4mm Ball

GB: XFLGA - 4 x 6 x 0.5mm, Pitch 0.8mm, 0.4mm Ball

BOOT BLOCK TYPE:

T: Top Boot

B: Bottom Boot

REVISION:

D

DENSITY & MODE:

160: 16Mb, x8/x16 Boot Block

TYPE:

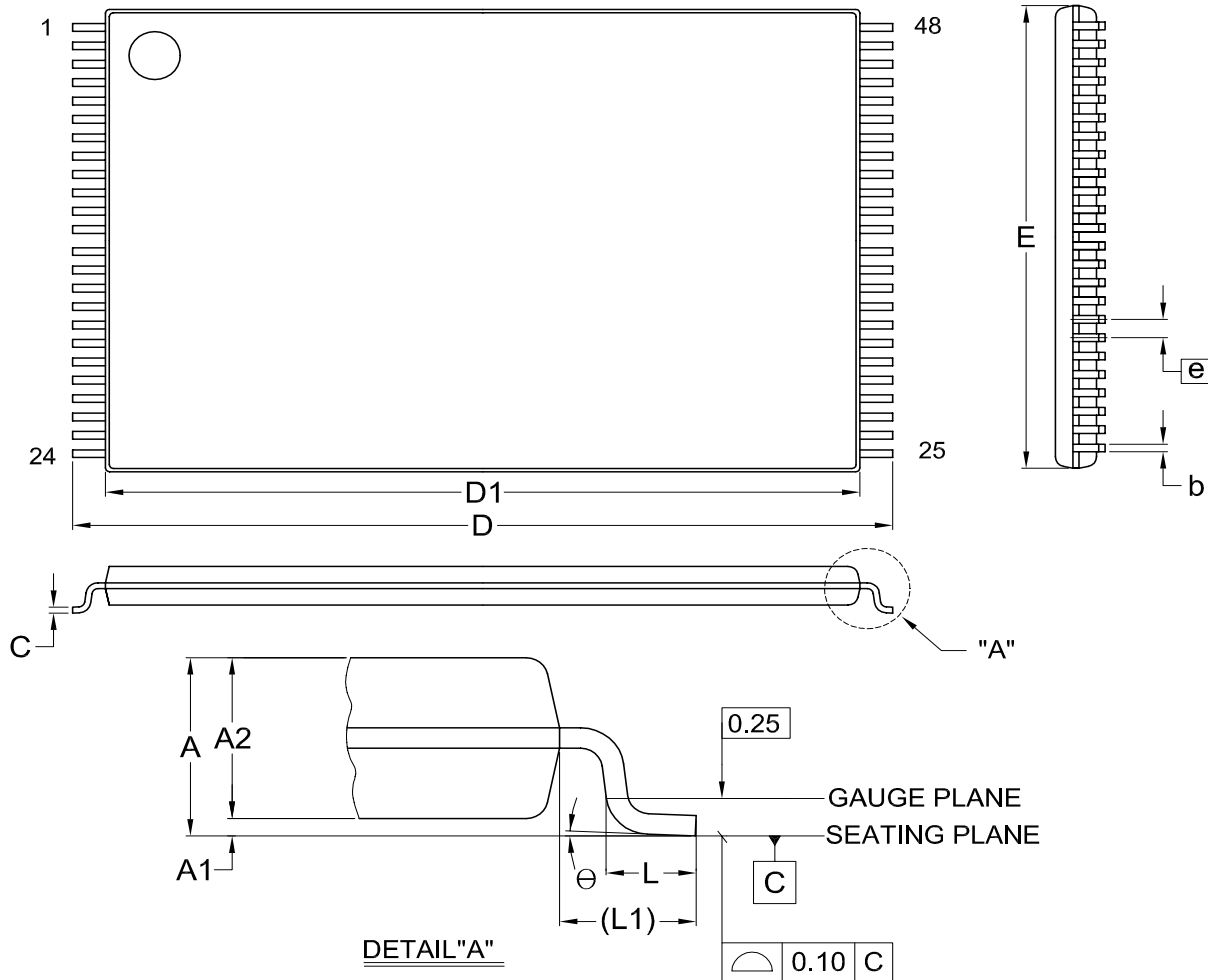
LV: 3V

DEVICE:

29:Flash

PACKAGE INFORMATION

Doc. Title: Package Outline for TSOP(I) 48L (12X20mm)NORMAL FORM



Dimensions (inch dimensions are derived from the original mm dimensions)

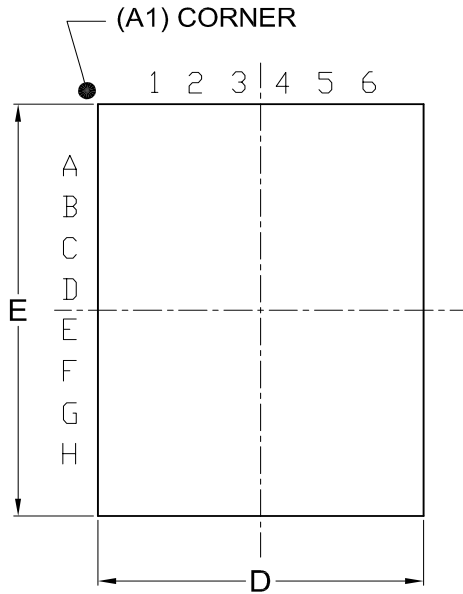
SYMBOL		A	A1	A2	b	C	D	D1	E	e	L	L1	θ
UNIT													
mm	Min.	—	0.05	0.95	0.17	0.10	19.80	18.30	11.90	---	0.50	0.70	0
	Nom.	—	0.10	1.00	0.20	0.13	20.00	18.40	12.00	0.50	0.60	0.80	5
	Max.	1.20	0.15	1.05	0.27	0.21	20.20	18.50	12.10	---	0.70	0.90	8
Inch	Min.	---	0.002	0.037	0.007	0.004	0.780	0.720	0.469	---	0.020	0.028	0
	Nom.	---	0.004	0.039	0.008	0.005	0.787	0.724	0.472	0.020	0.024	0.031	5
	Max.	0.047	0.006	0.041	0.011	0.008	0.795	0.728	0.476	---	0.028	0.035	8

Dwg. No.	Revision	Reference		
		JEDEC	EIAJ	
6110-1607	9	MO-142		

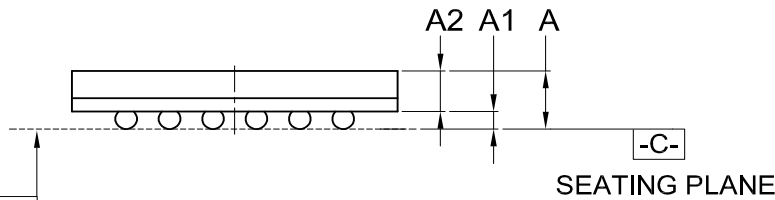
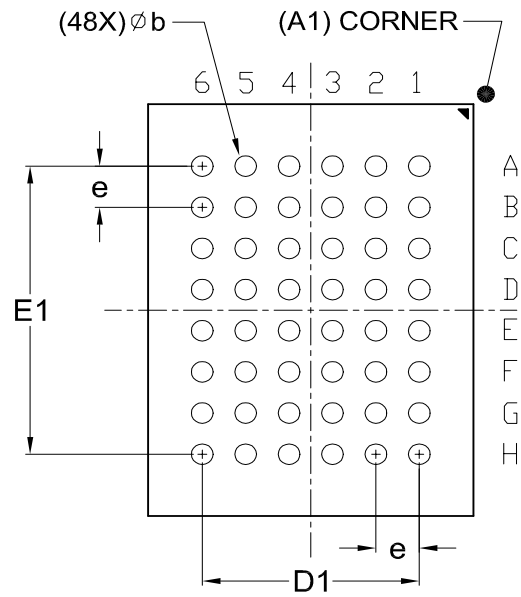
48-Ball TFBGA (for MX29LV160D TXBI/BXBI)

Doc. Title: Package Outline for CSP 48BALL(6X8X1.2MM,BALL PITCH 0.8MM,BALL DIAMETER 0.3MM)

TOP VIEW



BOTTOM VIEW



0.08 C

Dimensions (inch dimensions are derived from the original mm dimensions)

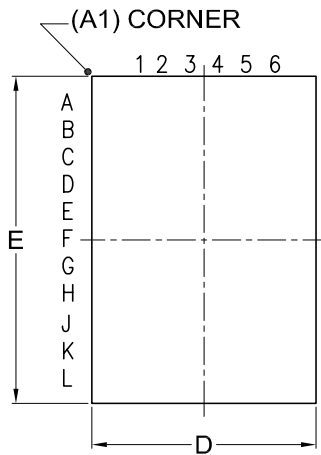
SYMBOL		A	A1	A2	b	D	D1	E	E1	e
mm	Min.	—	0.18	0.65	0.25	5.90		7.90		
	Nom.	—	0.23	—	0.30	6.00	4.00	8.00	5.60	0.80
	Max.	1.20	0.28	—	0.35	6.10		8.10		
Inch	Min.	---	0.007	0.026	0.010	0.232		0.311		
	Nom.	---	0.009	---	0.012	0.236	0.157	0.315	0.220	0.031
	Max.	0.047	0.011	---	0.014	0.240		0.319		

Dwg. No.	Revision	Reference		
		JEDEC	EIAJ	
6110-4201	7	MO-210		

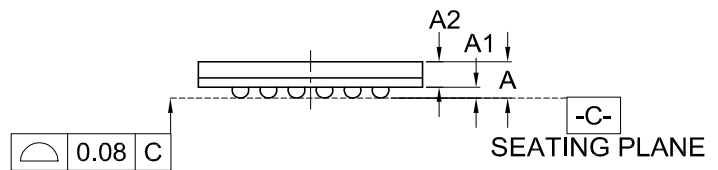
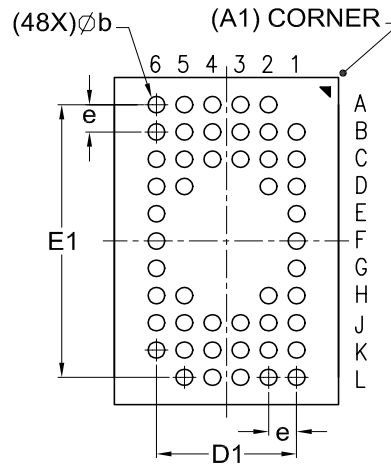
48-Ball WFBGA (for MX29LV160D TXHI/BXHI)

Doc. Title: Package Outline for CSP 48BALL(4X6X0.75MM,BALL PITCH 0.5MM,BALL DIAMETER 0.3MM)

TOP VIEW



BOTTOM VIEW



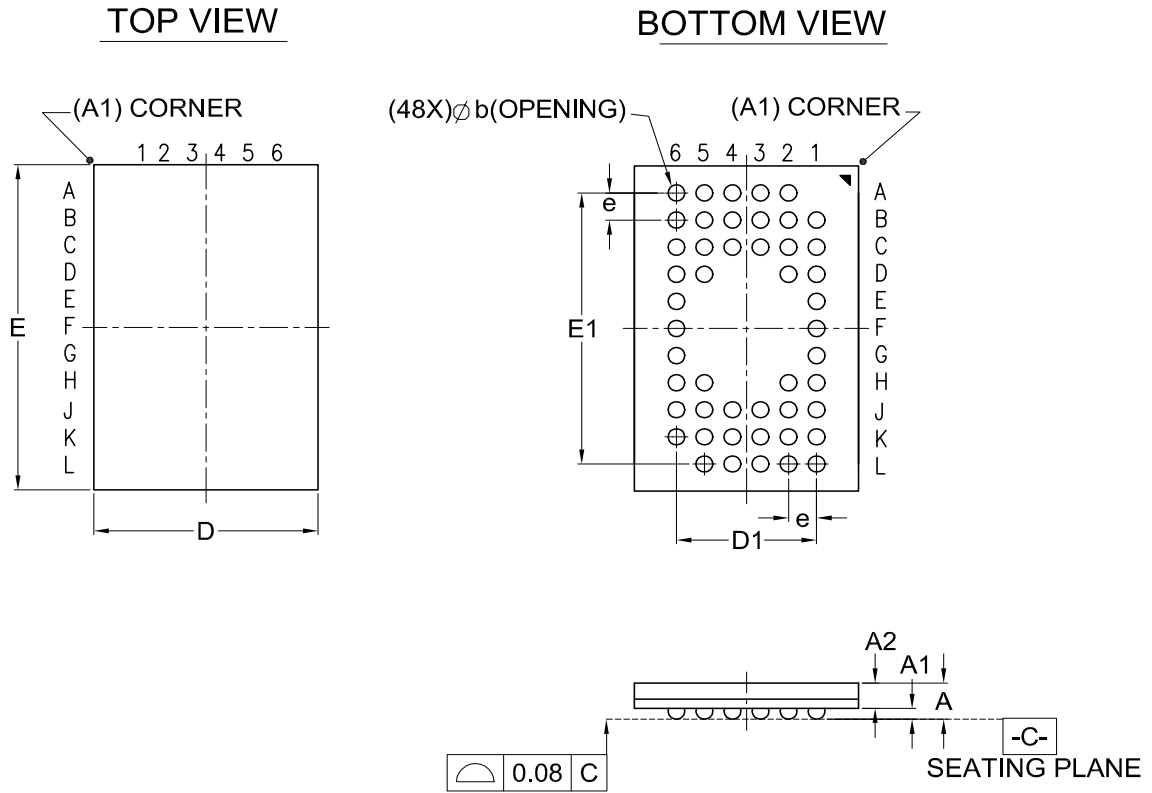
Dimensions (inch dimensions are derived from the original mm dimensions)

SYMBOL		A	A1	A2	b	D	D1	E	E1	e
UNIT										
mm	Min.	---	0.16	0.41	0.25	3.90		5.90		
	Nom.	---	0.21	---	0.30	4.00	2.50	6.00	5.00	0.50
	Max.	0.75	0.26	---	0.35	4.10		6.10		
Inch	Min.	---	0.006	0.016	0.010	0.154		0.232		
	Nom.	---	0.008	---	0.012	0.157	0.098	0.236	0.197	0.020
	Max.	0.030	0.010	---	0.014	0.161		0.240		

Dwg. No.	Revision	Reference			
		JEDEC	EIAJ		
6110-4250	2				

48-Ball XFLGA (for MX29LV160D TGBI/BGBI)

Doc. Title: Package Outline for XFLGA 48L (4x6x0.5MM, LAND PITCH 0.5MM, LAND OPENING 0.25MM)



Dimensions (inch dimensions are derived from the original mm dimensions)

SYMBOL		A	A1	A2	b	D	D1	E	E1	e
mm	Min.	---	0.02	0.33	0.20	3.90	—	5.90	—	—
	Nom.	---	0.05	---	0.25	4.00	2.50	6.00	5.00	0.50
	Max.	0.50	0.08	---	0.30	4.10	—	6.10	—	—
Inch	Min.	—	0.001	0.013	0.008	0.154	—	0.232	—	—
	Nom.	—	0.002	---	0.010	0.157	0.098	0.236	0.197	0.020
	Max.	0.020	0.003	---	0.012	0.161	—	0.240	—	—

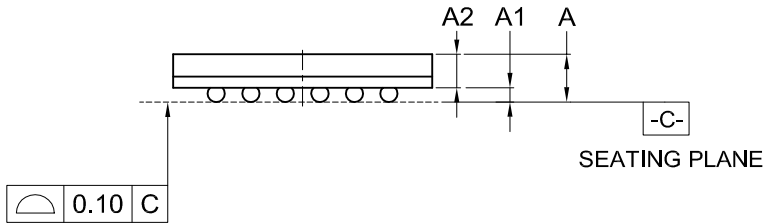
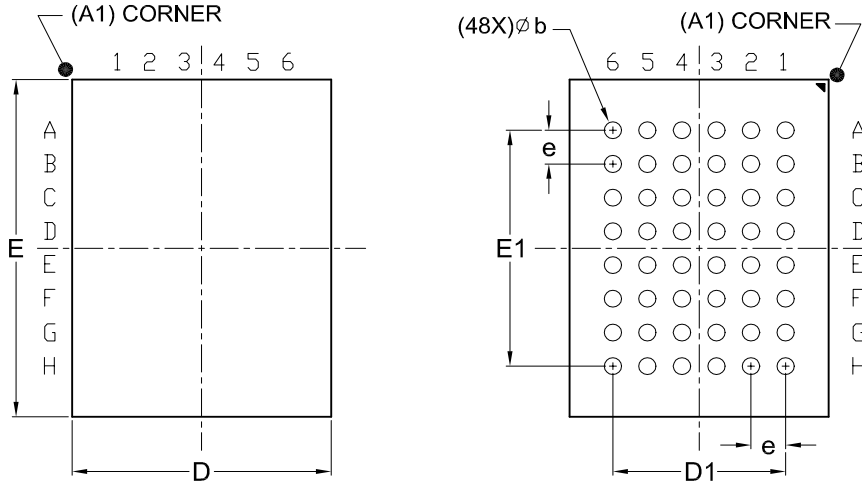
Dwg. No.	Revision	Reference			
		JEDEC	EIAJ		
6110-3501	1	MO-222			

48-Ball LFBGA (for MX29LV160D TXEI/BXEI)

Doc. Title: Package Outline for CSP 48BALL(6X8X1.3MM,BALL PITCH 0.8MM,BALL DIAMETER 0.4MM)

TOP VIEW

BOTTOM VIEW



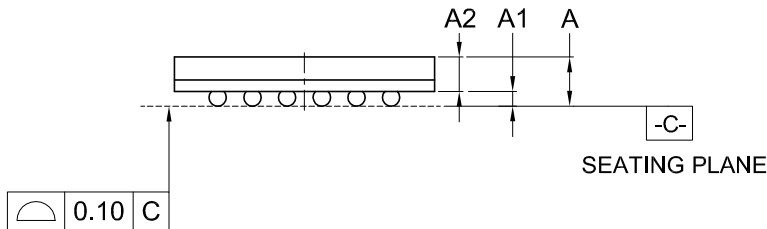
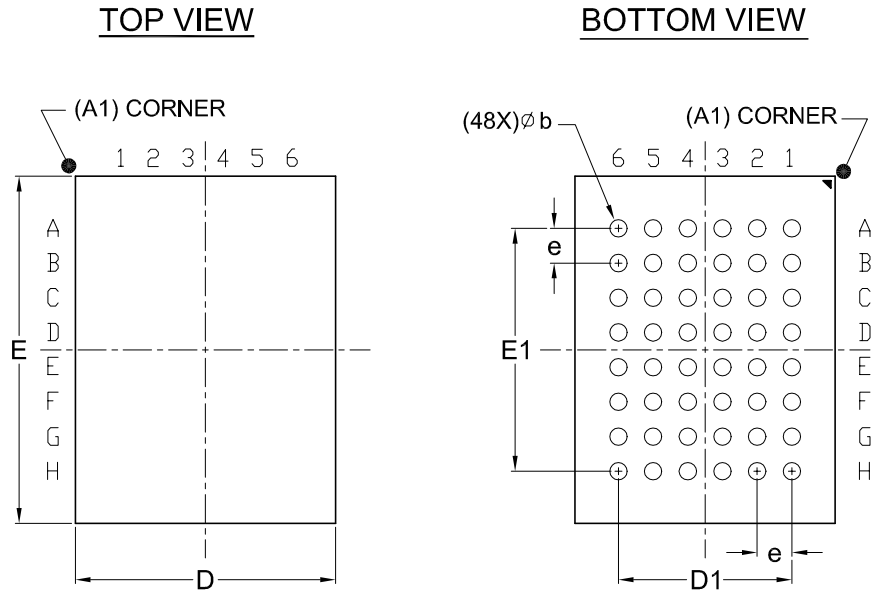
Dimensions (inch dimensions are derived from the original mm dimensions)

SYMBOL		A	A1	A2	b	D	D1	E	E1	e
mm	Min.	---	0.25	0.65	0.35	5.90		7.90		
	Nom.	---	0.30	---	0.40	6.00	4.00	8.00	5.60	0.80
	Max.	1.30	0.35	---	0.45	6.10		8.10		
Inch	Min.	—	0.010	0.026	0.014	0.232		0.311		
	Nom.	—	0.012	—	0.016	0.236	0.157	0.315	0.220	0.031
	Max.	0.051	0.014	—	0.018	0.240		0.319		

Dwg. No.	Revision	Reference			
		JEDEC	EIAJ		
6110-4202	5	MO-219			

48-Ball TFBGA (for MX29LV160D TXGI/BXGI)

Doc. Title: Package Outline for CSP 48BALL (6X8X1.2MM , BALL PITCH 0.8MM , DIAMETER 0.4MM)



Dimensions (inch dimensions are derived from the original mm dimensions)

SYMBOL		A	A1	A2	b	D	D1	E	E1	e
UNIT										
mm	Min.	—	0.25	0.65	0.35	5.90	---	7.90	—	—
	Nom.	—	0.30	—	0.40	6.00	4.00	8.00	5.60	0.80
	Max.	1.20	0.35	—	0.45	6.10	---	8.10	—	—
Inch	Min.	—	0.010	0.026	0.014	0.232	---	0.311	—	—
	Nom.	—	0.012	---	0.016	0.236	0.157	0.315	0.220	0.031
	Max.	0.047	0.014	---	0.018	0.240	---	0.319	—	—

Dwg. No.	Revision	Reference			
		JEDEC	EIAJ		
6110-4258	1	MO-219			



REVISION HISTORY

Revision No.	Description	Page	Date
1.0	1. Changed Icr1 from 7mA(typ.) to 5mA(typ.) 2. Removed "Advanced Information"	P5,30 P5	AUG/11/2008
1.1	1. Revised data retention from 10 years to 20 years 2. Added TXGI/BXGI ordering information and part name information (TFBGA PACKAGE) 3. Added Tsw (AC/WAVEFORM, Min. 45ns) 4. Added WP#ACC PIN note	P5-6,56 P57-58,64 P32,34 P9	MAY/18/2009
1.2	1. Modified description for RoHS compliance 2. Modified Figure 11. CE# Controlled Write Timing Waveform	P5,58 P42	DEC/22/2011



MACRONIX
INTERNATIONAL Co., LTD.

MX29LV160D T/B

Except for customized products which has been expressly identified in the applicable agreement, Macronix's products are designed, developed, and/or manufactured for ordinary business, industrial, personal, and/or household applications only, and not for use in any applications which may, directly or indirectly, cause death, personal injury, or severe property damages. In the event Macronix products are used in contradicted to their target usage above, the buyer shall take any and all actions to ensure said Macronix's product qualified for its actual use in accordance with the applicable laws and regulations; and Macronix as well as it's suppliers and/or distributors shall be released from any and all liability arisen therefrom.

Copyright© Macronix International Co., Ltd. 2007~2011. All rights reserved.

Macronix, MXIC, MXIC Logo, MX Logo, Integrated Solutions Provider, NBit, NBit, Macronix NBit, eLiteFlash, XtraROM, Phines, BE-SONOS, KSMC, Kingtech, MXSMIO, Macronix vEE are trademarks or registered trademarks of Macronix International Co., Ltd. The names and brands of other companies are for identification purposes only and may be claimed as the property of the respective companies.

For the contact and order information, please visit Macronix's Web site at: <http://www.macronix.com>

Looking for pricing, stock, or lifecycle information?

Click below to explore more details on WIN SOURCE:

 [View MX29LV160DTTI-70G on WIN SOURCE](#)

 [Macronix Information](#)

Optimize Your Supply Chain with WIN SOURCE Solutions

-  Global Sourcing Solution
-  Obsolete Management
-  Cost Control Management
-  Shortage Management
-  Alternative Solution
-  Excess Inventory Management