

NCP5395

Product Preview

2/3/4-Phase Controller with On Board Gate Drivers for CPU Applications

The NCP5395 provides up to a four-phase buck solution which combines differential voltage sensing, differential phase current sensing, adaptive voltage positioning, and on board gate drivers. Dual-edge pulse-width modulation (PWM) combined with inductor current sensing reduces system cost by providing the fastest initial response to dynamic load events. Dual-edge multiphase modulation reduces the total bulk and ceramic output capacitance required to meet transient regulation specifications.

The on board gate drivers includes adaptive non overlap and power saving operation. A high performance operational error amplifier is provided to simplify compensation of the system. Patented Dynamic Reference Injection further simplifies loop compensation by eliminating the need to compromise between closed-loop transient response and Dynamic V_{ID} performance.

Features

- Meets Intel's VR11.1 Specifications
- Meets AMD 6 Bit Code Specifications
- Dual-edge PWM for Fastest Initial Response to Transient Loading
- High Performance Operational Error Amplifier
- Internal Soft Start
- Dynamic Reference Injection (Patent #US07057381)
- DAC Range from 0.5 V to 1.6 V
- DAC Feed Forward Function (Patent Pending)
- $\pm 0.5\%$ DAC Voltage Accuracy from 1.0 V to 1.6 V
- True Differential Remote Voltage Sensing Amplifier
- Phase-to-Phase Current Balancing
- "Lossless" Differential Inductor Current Sensing
- Differential Current Sense Amplifiers for Each Phase
- Adaptive Voltage Positioning (AVP)
- Oscillator Frequency Range of 125 kHz – 1 MHz
- Latched Over Voltage Protection (OVP)
- Guaranteed Startup into Pre-Charged Loads
- Threshold Sensitive Enable Pin for VTT Sensing
- Power Good Output with Internal Delays
- Thermally Compensated Current Monitoring
- Thermal Shutdown Protection
- Adaptive-Non-Overlap Gate Drive Circuit
- Output Disable Control Turn Off of Both Phase Pair MOSFETs
- This is a Pb-Free Device

Applications

- Desktop Processors

This document contains information on a product under development. ON Semiconductor reserves the right to change or discontinue this product without notice.



ON Semiconductor®

<http://onsemi.com>

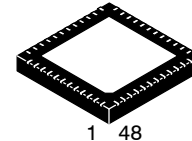

1 48

**QFN48
CASE 485K
PLASTIC**

MARKING DIAGRAM

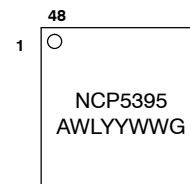

- A = Assembly Location
- WL = Wafer Lot
- YY = Year
- WW = Work Week
- G = Pb-Free Package

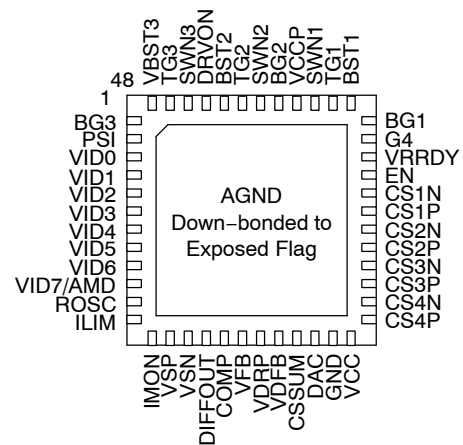

ORDERING INFORMATION

Device	Package	Shipping†
NCP5395MNR2G	QFN48 (Pb-Free)	2500/Tape & Reel

†For information on tape and reel specifications, including part orientation and tape sizes, please refer to our Tape and Reel Packaging Specifications Brochure, BRD8011/D.

NCP5395

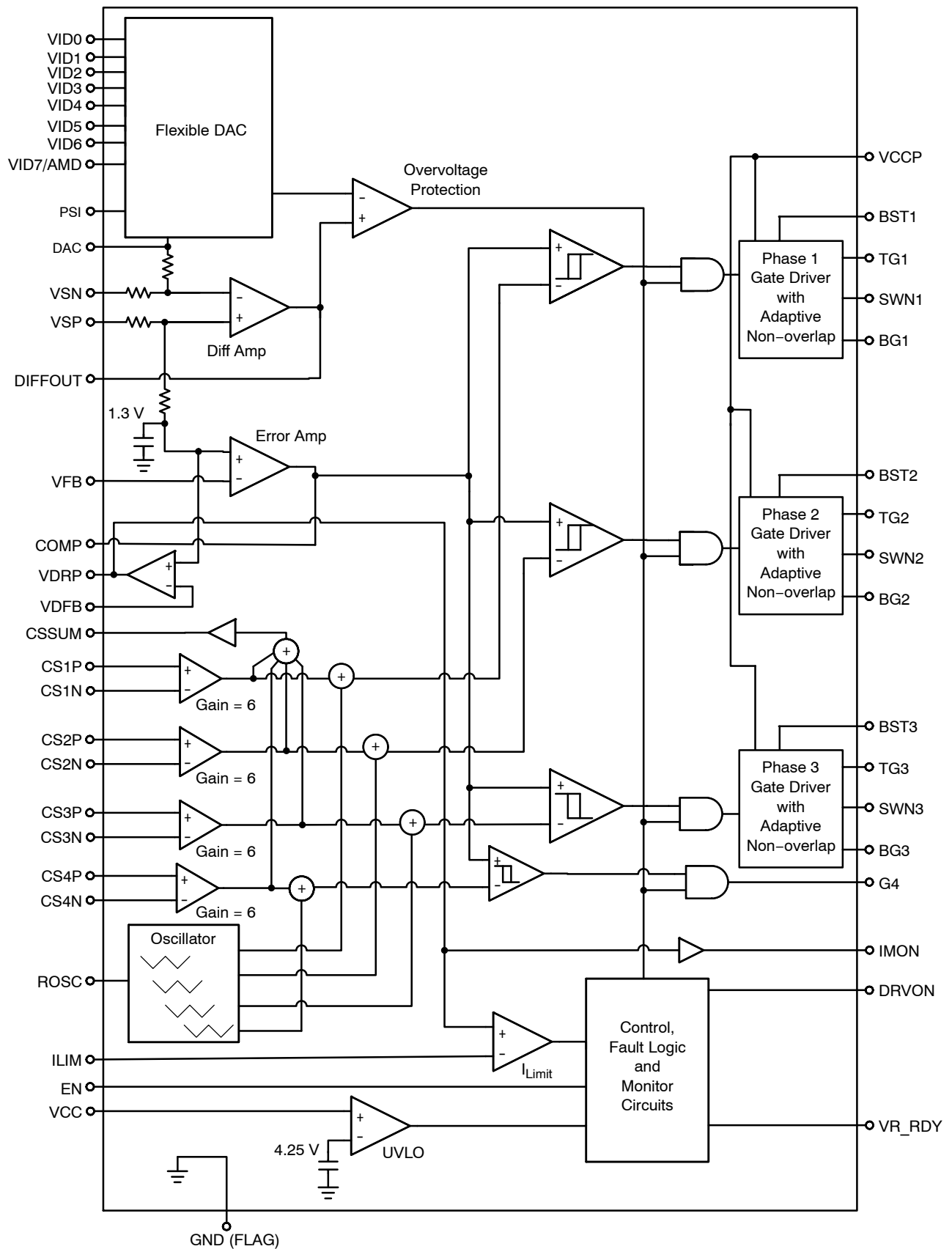

Figure 1. NCP5395 Functional Block Diagram

NCP5395

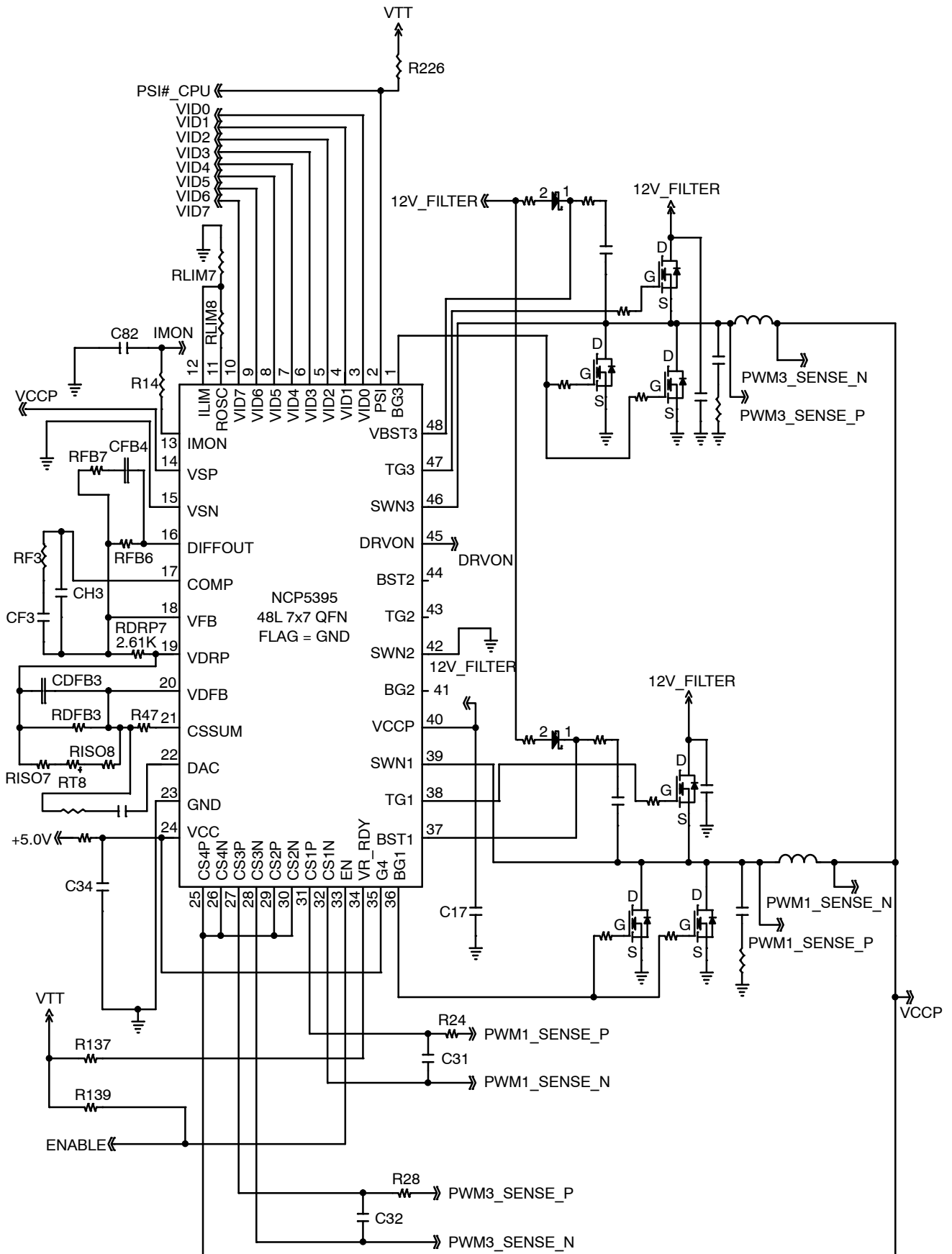

Figure 2. Typical 2 Phase Application

NCP5395

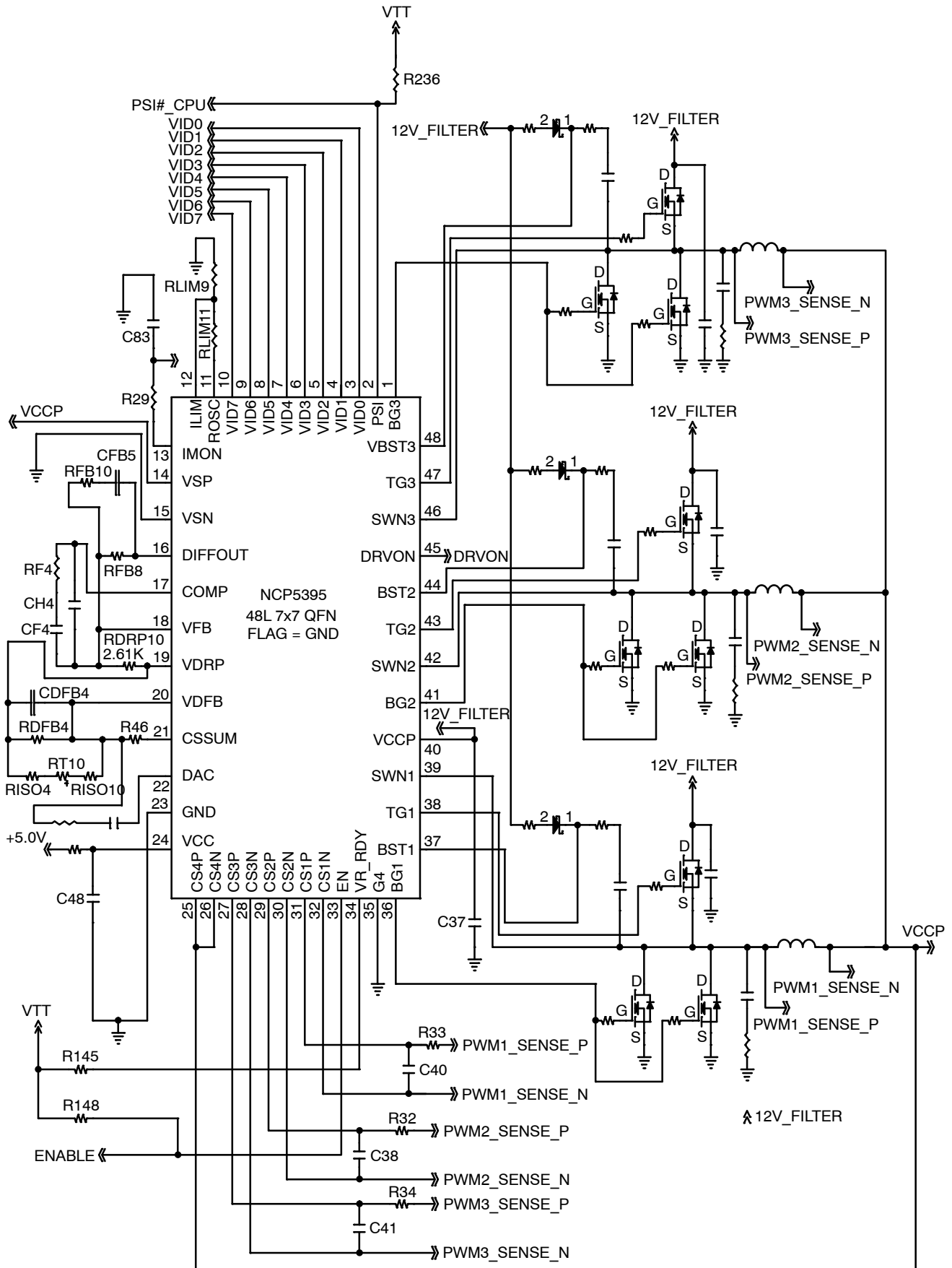

Figure 3. Typical 3 Phase Application

NCP5395

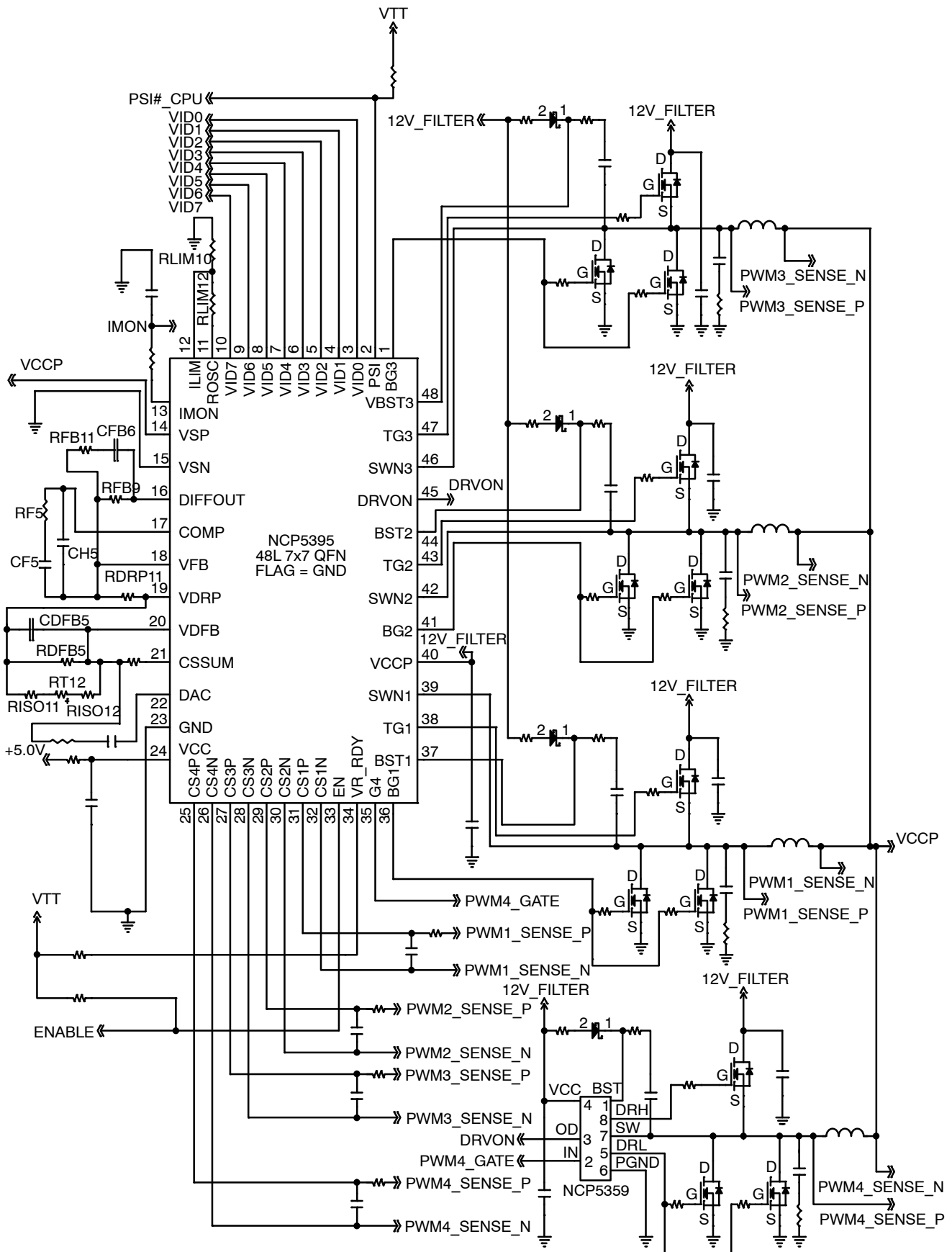

Figure 4. Typical 4 Phase Application

NCP5395

Table 1. Pin Descriptions

Pin No.	Symbol	Description
1	BG3	Low side gate drive #3
2	PSI	Selects DAC Decode.
3	VID0	Voltage ID DAC input
4	VID1	Voltage ID DAC input
5	VID2	Voltage ID DAC input
6	VID3	Voltage ID DAC input
7	VID4	Voltage ID DAC input
8	VID5	Voltage ID DAC input
9	VID6	Voltage ID DAC input
10	VID7/AMD	Voltage ID DAC input. Pull to V _{CC} (5 V) to enable AMD 6-bit DAC code.
11	ROSC	A resistance from this pin to ground programs the oscillator frequency and provides a 2 V reference for programming the ILIM voltage.
12	ILIM	Over current shutdown threshold setting. $ILIM = VDRP - 1.3 V$. Resistor divide ROSC to set threshold
13	IMON	0 to 1 Volt analog signal proportional to the output load current. VSN referenced Clamped to 1.1 V _{max}
14	VSP	Non-inverting input to the internal differential remote sense amplifier
15	VSN	Inverting input to the internal differential remote sense amplifier
16	DIFFOUT	Output of the differential remote sense amplifier
17	COMP	Output of the compensation amplifier
18	VFB	Compensation amplifier voltage feedback
19	VDRP	Voltage output signal proportional to current used for current limit and output voltage droop
20	VDFB	Droop Amplifier Voltage Feedback
21	CSSUM	Inverted Sum of the Differential Current Sense inputs
22	DAC	DAC output used to provide feed forward for dynamic VID
23	GND	Ground
24	VCC	Power for the internal control circuits with UVLO monitor
25	CS4P	Non-inverting input to current sense amplifier #4
26	CS4N	Inverting input to current sense amplifier #4
27	CS3P	Non-inverting input to current sense amplifier #3
28	CS3N	Inverting input to current sense amplifier #3
29	CS2P	Non-inverting input to current sense amplifier #2
30	CS2N	Inverting input to current sense amplifier #2
31	CS1P	Non-inverting input to current sense amplifier #1
32	CS1N	Inverting input to current sense amplifier #1
33	EN	Threshold sensitive input. High = startup, Low =shutdown.
34	VR_RDY	Open collector output. High indicates that the output is regulating
35	G4	PWM output pulse to gate driver.
36	BG1	Low side gate drive #1
37	BST1	Upper MOSFET floating bootstrap supply for driver#1
38	TG1	High side gate drive #1
39	SWN1	Switch Node #1
40	VCCP	Power V _{CC} for gate drivers with UVLO monitor
41	BG2	Low side gate drive #2
42	SWN2	Switch Node #2
43	TG2	High side gate drive #2
44	BST2	Upper MOSFET floating bootstrap supply for driver#2
45	DRVON	Bidirectional Gate Drive Enable
46	SWN3	Switch Node #3
47	TG3	High side gate drive #3
48	BST3	Upper MOSFET floating bootstrap supply for driver#3
FLAG	GND	Power supply return (QFN Flag)

NCP5395

ABSOLUTE MAXIMUM RATINGS

Rating	Symbol	Value	Unit
--------	--------	-------	------

ELECTRICAL INFORMATION

Controller Power Supply Voltages to GND	V_{CC}	-0.3, 7	V
Driver Power Supply Voltages to GND	V_{CCP}	-0.3, 15	V
High-Side Gate Driver Supplies: BSTx to SWNx	$V_{BST} - V_{SWN}$	35 V wrt/GND 40 V \leq 50 ns wrt/GND -0.3, 15 wrt/SWN	V
High-Side FET Gate Driver Voltages: TGx to SWNx	$V_{TG} - V_{SWN}$	BOOT + 0.3 V 35 V \leq 50 ns wrt/GND -0.3, 15 wrt/SWN -2 V (200 ns)	V
Switch Node: SWNx	V_{SWN}	35 40 V \leq 50 ns wrt/GND -5 VDC -10 V (200 ns)	V
Low-Side Gate Drive: BGx	$V_{BG} - AGND$	$V_{CC} + 0.3$ V -0.3 VDC (200 ns)	V
Logic Inputs	V_{LOGIC}	-0.3, 6	V
GND	V_{GND}	0	V
V-		GND \pm 300	mV
I _{mon} Out	V_{IMON}	1.1	V
All Other Pins		-0.3, 5.5	V

THERMAL INFORMATION

Thermal Characteristic QFN Package (Note 1)	$R_{\theta JA}$	TBD	°C/W
Operating Junction Temperature Range (Note 2)	T_J	0 to 125	°C
Operating Ambient Temperature Range	T_{AMB}	0 to +70	°C
Maximum Storage Temperature Range	T_{STG}	-55 to +150	°C
Moisture Sensitivity Level QFN Package	MSL	1	

Stresses exceeding Maximum Ratings may damage the device. Maximum Ratings are stress ratings only. Functional operation above the Recommended Operating Conditions is not implied. Extended exposure to stresses above the Recommended Operating Conditions may affect device reliability.

*All signals referenced to GND unless noted otherwise.

*The maximum package power dissipation must be observed.

1. JESD 51-5 (1S2P Direct-Attach Method) with 0 LFM
2. Operation at -40°C to 0°C guaranteed by design, not production tested.

NCP5395

ELECTRICAL CHARACTERISTICS

0°C < T_A < 70°C; 0°C < T_J < 125°C; 4.75 < V_{CC} < 5.25 V; All DAC Codes; C_{VCC} = 0.1 μF unless otherwise noted.

Parameter	Test Conditions	Min	Typ	Max	Unit
ERROR AMPLIFIER					
Input Bias Current		-200	-	200	nA
Open Loop DC Gain	C _L = 60 pF to GND, R _L = 10 kΩ to GND	-	100	-	dB
Open Loop Unity Gain Bandwidth	C _L = 60 pF to GND, R _L = 10 kΩ to GND	-	18	-	MHz
Open Loop Phase Margin	C _L = 60 pF to GND, R _L = 10 kΩ to GND	-	70	-	°
Slew Rate	ΔV _{in} = 100 mV, G = -10V/V, ΔV _{out} = 1.5 V - 2.5 V, C _L = 60 pF to GND, DC Load = ±125 μA to GND	-	10	-	V/μs
Maximum Output Voltage	10 mV of Overdrive, I _{SOURCE} = 2.0 mA	3.0	-	-	V
Minimum Output Voltage	10 mV of Overdrive, I _{SINK} = 500 μA	-	-	75	mV
Output Source Current	10 mV of Overdrive, V _{out} = 3.5 V	1.5	2.0	-	mA
Output Sink Current	10 mV of Overdrive, V _{out} = 0.1 V	0.75	1.0	-	mA

DIFFERENTIAL SUMMING AMPLIFIER

V+ Input Pull down Resistance	DRVON = low DRVON = high	- -	0.6 6.0	- -	kΩ
V+ Input Bias Voltage	DRVON = low DRVON = high	- -	0.5 0.86	- -	V
Input Voltage Range (Note 4)		-0.3	-	3.0	V
-3 dB Bandwidth	C _L = 80 pF to GND, R _L = 10 kΩ to GND	-	15	-	MHz
Closed Loop DC gain VS to Diffout (Note 4)	VS+ to VS- = 0.5 V to 1.6 V	0.98	1.0	1.02	V/V
Maximum Output Voltage	10 mV of Overdrive, I _{SOURCE} = 2 mA	3.0	-	-	V
Minimum Output Voltage	10 mV of Overdrive, I _{SINK} = 1 mA	-	-	0.5	V
Output Source Current	10 mV of Overdrive, V _{out} = 3 V	1.5	2.0	-	mA
Output Sink Current	10 mV of Overdrive, V _{out} = 0.2 V	1.0	1.5	-	mA

INTERNAL OFFSET VOLTAGE

Offset Voltage to the (+) Pin of the Error Amp & the VDRP Pin		-2	0	+2	mV
---	--	----	---	----	----

- Design guaranteed.
- For propagation delays, "tpdh" refers to the specified signal going high "tpdl" refers to it going low. Reference Gate Timing Diagram.
- Guaranteed by design; not tested in production.
- Internal DAC voltage is centered 19 mV below the listed Voltage. For VR11.1/VR11.0/VR10
- No DAC offset is implemented for AMD operation.

NCP5395

ELECTRICAL CHARACTERISTICS

0°C < T_A < 70°C; 0°C < T_J < 125°C; 4.75 < V_{CC} < 5.25 V; All DAC Codes; C_{VCC} = 0.1 μF unless otherwise noted.

Parameter	Test Conditions	Min	Typ	Max	Unit
VDROOP AMPLIFIER					
Input Bias Current		-200	-	200	nA
Inverting Voltage Range		0	1.3	3.0	V
Open Loop DC Gain	C _L = 20 pF to GND including ESD R _L = 1 kΩ to GND	-	100	-	dB
Open Loop Unity Gain Bandwidth	C _L = 20 pF to GND including ESD R _L = 1 kΩ to GND	-	18	-	MHz
Open Loop Phase Margin	C _L = 20 pF to GND including ESD R _L = 1 kΩ to GND	-	70	-	°
Slew Rate	C _L = 20 pF to GND including ESD R _L = 1 kΩ to GND	-	10	-	V/μs
Maximum Output Voltage	10 mV of Overdrive, I _{SOURCE} = 4.0 mA	3.0	-	-	V
Minimum Output Voltage	10 mV of Overdrive, I _{SINK} = 1.0 mA	-	-	1.0	V
Output Source Current	10 mV of Overdrive, V _{out} = 3.0 V	4.0	-	-	mA
Output Sink Current	10 mV of Overdrive, V _{out} = 1.0 V	1.0	-	-	mA

CSSUM AMPLIFIER

Current Sense Input to CSSUM Gain	-75 mV < CS < 75 mV	-3.793	-3.70	-3.608	V/V
Current Sense Input to V _{DRP} -3 dB Bandwidth	C _L = 10 pF to GND, R _L = 10 kΩ to GND	-	12	-	MHz
Current Summing Amp Output Offset Voltage	CS _x - CS _{Nx} = 0, CS _x = 1 V	-8.0	-	+8.0	mV
Maximum CSSUM Output Voltage	CS _x - CS _{Nx} = -0.2 V (all phases) I _{SOURCE} = 1 mA	3.0	-	-	V
Minimum CSSUM Output Voltage	CS _x - CS _{Nx} = 0.7 V (all phases) I _{SINK} = 1 mA	-	-	0.3	V
Output Source Current	V _{out} = 3.0 V	1.0	-	-	mA
Output Sink Current	V _{out} = 0.3 V	4.0	-	-	mA

PSI

Enable High Input Leakage Current	External 1k Pull-up to 3.3 V	-	-	1.0	μA
Threshold		450	600	770	mV
Delay		-	100	-	ns

DRVON

Output High Voltage	Sourcing 500 μA	3.0	-	-	V
Output Low Voltage	Sinking 500 μA	-	-	0.7	V
Delay Time	Propagation delays	-	10	-	ns
Rise Time	C _L (PCB) = 20 pF, ΔV _o = 10% to 90%	-	10	-	ns
Fall Time	C _L (PCB) = 20 pF, ΔV _o = 10% to 90%	-	10	-	ns
Internal Pull-Down Resistance		35	70	140	kΩ
V _{CC} Voltage when DRVON Output Valid		-	-	2.0	V

3. Design guaranteed.

4. For propagation delays, "tpdh" refers to the specified signal going high "tpdl" refers to it going low. Reference Gate Timing Diagram.

5. Guaranteed by design; not tested in production.

6. Internal DAC voltage is centered 19 mV below the listed Voltage. For VR11.1/VR11.0/VR10

7. No DAC offset is implemented for AMD operation.

NCP5395

ELECTRICAL CHARACTERISTICS

0°C < T_A < 70°C; 0°C < T_J < 125°C; 4.75 < V_{CC} < 5.25 V; All DAC Codes; C_{VCC} = 0.1 μF unless otherwise noted.

Parameter	Test Conditions	Min	Typ	Max	Unit
-----------	-----------------	-----	-----	-----	------

CURRENT SENSE AMPLIFIERS

Input Bias Current	CSx = CSxN = 1.4 V	-50	-	50	nA
Common Mode Input Voltage Range		-0.3	-	2.0	V
Differential Mode Input Voltage Range		-120	-	120	mV
Current Sharing Output Voltage	CSx = CSxN = 1.00 V,	-TBD	-	TBD	mV
Current Sense Input to PWM Gain	0 V < CSx - CSxN < 0.1 V,	5.4	5.7	6.0	V/V
Current Sense Input to CSSUM Gain	0 V < CSx - CSxN < 0.1 V	-3.793	-3.7	-3.608	V/V

IMON

V _{DRP} to IMON Gain	1.325 V > V _{DRP} > 1.75 V	1.89	2.0	2.02	V/V
Current Sense Input to V _{DRP} -3 dB Bandwidth	C _L = 30 pF to GND, R _L = 100 kΩ to GND	-	4.0	-	MHz
V _{DRP} to IMON Output Slew Rate	C _L = 30 pF to GND, Load = 100k to GND	-	TBD	-	V/μs
Output Referred Offset Voltage	V _{DRP} = 1.5 V, I _{SOURCE} = 0 mA	-TBD	-	TBD	mV
Minimum Output Voltage	V _{DRP} = 1.3 V, I _{SINK} = 25 μA	-	-	0.1	V
Maximum Output Voltage	I _{out} = 300 μA	1.0	-	-	V
Output Sink Current	V _{out} = 0.3 V	175	-	-	μA
Maximum Clamp Voltage	IMON - VSN V _{DRP} = HIGH R _{LOAD} = Open	1.1	-	1.15	V

OSCILLATOR

Switching Frequency Range		100	-	1100	kHz
Switching Frequency Accuracy	200 kHz < F _{SW} < 600 kHz	-	-	5.0	%
Switching Frequency Accuracy	100 kHz < F _{SW} < 1 MHz	-	-	10	%
Switching Frequency Accuracy (2ph or 4ph)	R _{OSC} = 69.8k	TBD	-	TBD	kHz
	R _{OSC} = 16.2k	475	-	525	
	R _{OSC} = 7.5k	TBD	-	TBD	
Switching Frequency Accuracy (3ph)	R _{OSC} = 69.8k	TBD	-	TBD	kHz
	R _{OSC} = 16.2k	494	-	546	
	R _{OSC} = 7.5k	TBD	-	TBD	
ROSC Output Voltage		1.93	2.00	2.05	V

MODULATORS (PWM Comparators)

Minimum Pulse Width	F _{sw} = 800 kHz	-	30	-	ns
Magnitude of the PWM Ramp		TBD	1.0	TBD	V
0% Duty Cycle	COMP Voltage when the PWM Outputs Remain LO	TBD	150	TBD	mV
100% Duty Cycle	COMP Voltage when the PWM Outputs Remain HI	-	1.15	-	V
PWM Phase Angle Error	Between Adjacent Phases	-TBD	-	TBD	°

VR_RDY (Power Good) OUTPUT

VR_RDY Output Saturation Voltage	I _{PGD} = 10 mA	-	-	0.4	V
----------------------------------	--------------------------	---	---	-----	---

- Design guaranteed.
- For propagation delays, "tpdh" refers to the specified signal going high "tpdl" refers to it going low. Reference Gate Timing Diagram.
- Guaranteed by design; not tested in production.
- Internal DAC voltage is centered 19 mV below the listed Voltage. For VR11.1/VR11.0/VR10
- No DAC offset is implemented for AMD operation.

NCP5395

ELECTRICAL CHARACTERISTICS

0°C < T_A < 70°C; 0°C < T_J < 125°C; 4.75 < V_{CC} < 5.25 V; All DAC Codes; C_{VCC} = 0.1 μF unless otherwise noted.

Parameter	Test Conditions	Min	Typ	Max	Unit
VR_RDY (Power Good) OUTPUT					
VR_RDY Rise Time	External pull-up of 1 kΩ to 1.25 V, C _{TOT} = 45 pF, ΔVo = 10% to 90%	–	100	150	ns
VR_RDY Output Voltage at Power-up	VR_RDY pulled up to 5 V via 2 kΩ, t _{R(VCC)} ≤ 3 × t _{R(5V)} 100 μs ≤ t _{R(VCC)} ≤ 20 ms	–	–	1.0	V
VR_RDY High – Output Leakage Current	VR_RDY = 5.5 V via 1 K	–	–	0.1	μA
VR_RDY Upper Threshold Voltage (INTEL)	VCore Increasing, DAC = 1.3 V	–	300	250	mV (below DAC)
VR_RDY Lower Threshold Voltage (INTEL)	VCore Decreasing, DAC = 1.3 V	390	350	300	mV (below DAC)
VR_RDY Lower Threshold Voltage (AMD)	VCore Increasing, DAC = 1.3 V	–	TBD	TBD	mV (below DAC)
VR_RDY Lower Threshold Voltage (AMD)	VCore Decreasing, DAC = 1.3 V	TBD	TBD	TBD	mV (below DAC)
VR_RDY Rising Delay	VCore Increasing	–	TBD	–	μs
VR_RDY Falling Delay	VCore Decreasing	–	5.0	–	μs

PWM G4 OUTPUT

Output High Voltage	Sourcing 500 μA	3.0	–	–	V
Mid Output Voltage		1.4	1.5	1.6	
Output Low Voltage	Sinking 500 μA	–	–	0.7	V
Delay + Rise Time	C _L (PCB) = 50 pF, ΔVo = V _{CC} to GND	–	10	15	ns
Delay + Fall Time	C _L (PCB) = 50 pF, ΔVo = GND to V _{CC}	–	10	15	ns
Tri-State Output Leakage	G _x = 2.5 V, x = 1–4	–	–	1.5	μA
Output Impedance – HI or LO State	Max Resistance to V _{CC} (HI) or GND (LO)	–	75	150	Ω
Minimum V _{CC} for Valid PWM Output Level		–	–	2.0	V
PWM 4 2/3/4 Phase Detection					
2 Phase Mode	Note Gate 4 tied to V _{CC}	3.2	–	V _{CC}	V
4 Phase Mode	Note Gate Driver will pull to 1.5 V	1.2	–	2.8	V
3 Phase Mode	Note Gate 4 tied to GND	0	–	0.8	V

DIGITAL SOFT-START

Soft-Start Ramp Time	DAC = 0 to DAC = 1.1 V	1.0	–	1.3	ms
VR11 V _{boot} time	Not used in Legacy Startup	400	500	600	μs

VID7/VR11/AMD/LEGACY INPUT

VID Threshold		450	600	770	mV
VR11 Input Bias Current		–100	–	100	nA

- Design guaranteed.
- For propagation delays, “tpdh” refers to the specified signal going high “tpdl” refers to it going low. Reference Gate Timing Diagram.
- Guaranteed by design; not tested in production.
- Internal DAC voltage is centered 19 mV below the listed Voltage. For VR11.1/VR11.0/VR10
- No DAC offset is implemented for AMD operation.

NCP5395

ELECTRICAL CHARACTERISTICS

0°C < T_A < 70°C; 0°C < T_J < 125°C; 4.75 < V_{CC} < 5.25 V; All DAC Codes; C_{VCC} = 0.1 μF unless otherwise noted.

Parameter	Test Conditions	Min	Typ	Max	Unit
-----------	-----------------	-----	-----	-----	------

VID7/VR11/AMD/LEGACY INPUT

Delay Before Latching VID Change (VID Deskewing)	Measured from the Edge of the 1st VID Change	200	–	300	ns
AMD Upper Threshold	Note: When above this threshold the controller will ramp directly to VID without stopping at V _{boot}	–	–	2.9	V
AMD Lower Threshold		2.4	–	–	V

ENABLE INPUT

Enable High Input Leakage Current	Pull-up to 1.3 V	–	–	200	nA
VR11.1 Threshold		450	600	770	mV
AMD Upper Threshold		–	1.3	1.5	V
AMD Lower Threshold		0.9	1.1	–	V
AMD Total Hysteresis	Rising– Falling Threshold	–	200	–	mV
Enable Delay Time	Measure time from Enable transitioning HI to when SS begins	–	3.5	–	ms

CURRENT LIMIT

ILIM to VDRP Gain		0.99	1.00	1.01	V/V
ILIM to VRDP Gain in PSI 4 Phase		–	0.25	–	V/V
ILIM to VDRP Gain in PSI 3 Phase		–	0.333	–	V/V
ILIM to VDRP Gain in PSI 2 Phase		–	0.5	–	V/V
ILIM Pin Input Bias Current		–	0.1	1.0	μA
ILIM Pin Working Voltage Range		0.1	–	2.0	V
ILIM accuracy	Measured with respect to the ILIM setting	–10	–	10	mV
Delay		–	–	120	ns

OVERVOLTAGE PROTECTION

VR11 Over Voltage Threshold		DAC+ 160	DAC+ 190	DAC+ 210	mV
AMD Over Voltage Threshold		DAC+ 210	DAC+ 235	DAC+ 260	mV
Delay		–	–	100	ns

UNDERVOLTAGE PROTECTION

V _{CC} UVLO Start Threshold		4.0	4.25	4.5	V
V _{CC} UVLO Stop Threshold		3.8	4.05	4.3	V
V _{CC} UVLO Hysteresis		–	200	–	mV

DAC OUTPUT

DAC Output Variation	I _{SOURCE} = 200 μA, All VIDs	–3.0	0	3.0	%
DAC Output Variation	I _{SINK} = 200 μA, All VIDs	–3.0	0	3.0	%
Output Source Current	V _{out} = 1.6 V	0	–	5.0	mA
Output Sink Current	V _{out} = 0.3 V	5.0	–	16	mA

- Design guaranteed.
- For propagation delays, “tpdh” refers to the specified signal going high “tpdl” refers to it going low. Reference Gate Timing Diagram.
- Guaranteed by design; not tested in production.
- Internal DAC voltage is centered 19 mV below the listed Voltage. For VR11.1/VR11.0/VR10
- No DAC offset is implemented for AMD operation.

NCP5395

ELECTRICAL CHARACTERISTICS

0°C < T_A < 70°C; 0°C < T_J < 125°C; 4.75 < V_{CC} < 5.25 V; All DAC Codes; C_{VCC} = 0.1 μF unless otherwise noted.

Parameter	Test Conditions	Min	Typ	Max	Unit
-----------	-----------------	-----	-----	-----	------

VID INPUTS

Threshold		450	600	770	mV
VR11 Mode Leakage		-100	-	100	nA
AMD Mode Input Bias Current		10	-	25	μA
Delay before Latching VID Change (VID Deskewing)	Measured from the edge of the 1 st VID change	200	-	300	ns
Delay Before Responding to Invalid or Shutdown Codes (Remove Spec)	Note: DAC must hold the last valid VID during this period	-	-	-	μs

DIGITAL DAC SLEW RATE LIMITER

Slew Rate Limit (Intel Mode)		12.5	-	15	mV/μs
Slew Rate Limit (AMD Mode)		3.125	-	3.75	mV/μs
Soft-Start Slew Rate		-	0.84	-	mV/μs

INPUT SUPPLY CURRENT

V _{CC} Operating Current	EN Low, No PWM	20	-	40	mA
-----------------------------------	----------------	----	---	----	----

PHASE SHEDDING

CS referred ph shed bias	CS2 through CS4	-	66	-	mV
--------------------------	-----------------	---	----	---	----

V_{CCP} SUPPLY VOLTAGE

V _{CCP} UVLO Start Threshold		8.2	9.0	9.5	V
V _{CCP} UVLO Stop Threshold		7.2	8.0	8.5	V
V _{CCP} UVLO Hysteresis		-	1.0	-	V
V _{CCP} POR	Voltage at which the Driver OVP becomes active	TBD	3.2	TBD	

BOOST PIN UVLO

BOOST V _{CC} UVLO Start Threshold		3.5		4.0	V
BOOST V _{CC} UVLO Stop Threshold		3.3		3.8	V
BOOST V _{CC} UVLO Hysteresis			200		mV

BOOST SUPPLY CURRENT

I _{VCCP_NORM} Quiescent Supply Current in Normal Operation	EN = V _{CC} , PWM = OSC, F _{SW} = 100k, C _{LOAD} = 0 p, V _{CCP} = 12 V	-	-	42	mA
I _{VCC_SBC} Standby Current	EN = GND; No switching, V _{CCP} = 12 V	20	-	40	mA
I _{BST1} Quiescent Supply Current in Normal Operation	IN = V _{CCP} , V _{CCP} = 12 V	-	10	TBD	mA
I _{BST2} Quiescent Supply Current in Normal Operation	IN = GND, V _{CCP} = 12 V	-	10	TBD	mA
I _{BST3} Quiescent Supply Current in Normal Operation	IN = GND, V _{CCP} = 12 V	-	10	TBD	
I _{BST1_SD} Standby Current	IN = V _{CCP} , V _{CCP} = 12 V	-	0.25	-	mA
I _{BST2_SD} Standby Current	IN = GND, V _{CCP} = 12 V	-	0.25	-	mA
I _{BST3_SD} Standby Current	IN = GND, V _{CCP} = 12 V	-	0.25	-	mA

STARTUP HIGH SIDE SHORT TRIP (Active only during 1st power on)

V _{swx} Output Overvoltage Trip Threshold at Startup	Power Startup time, V _{CC} > 9 V	1.75	-	2.0	V
---	---	------	---	-----	---

- Design guaranteed.
- For propagation delays, "tpdh" refers to the specified signal going high "tpdl" refers to it going low. Reference Gate Timing Diagram.
- Guaranteed by design; not tested in production.
- Internal DAC voltage is centered 19 mV below the listed Voltage. For VR11.1/VR11.0/VR10
- No DAC offset is implemented for AMD operation.

NCP5395

ELECTRICAL CHARACTERISTICS

0°C < T_A < 70°C; 0°C < T_J < 125°C; 4.75 < V_{CC} < 5.25 V; All DAC Codes; C_{VCC} = 0.1 μF unless otherwise noted.

Parameter	Test Conditions	Min	Typ	Max	Unit
-----------	-----------------	-----	-----	-----	------

HIGH SIDE DRIVER

R _{H_TG} Output Resistance, Sourcing	V _{BST} - V _{SW} = 12 V	-	1.8	4.2	Ω
R _{H_TG} Output Resistance, Sinking	V _{BST} - V _{SW} = 12 V	-	1.0	2.2	Ω
T _{rDRVH} Transition Time	C _{LOAD} = 3 nF, V _{BST} - V _{SW} = 12 V	-	16	-	ns
T _{fDRVH} Transition Time	C _{LOAD} = 3 nF, V _{BST} - V _{SW} = 12 V	-	11	-	ns
T _{pdhDRVH} Propagation Delay (Note 4)	Driving High, C _{LOAD} = 3 nF, V _{CCP} = 12 V	-	20	-	ns
T _{pdhDRVH} Propagation Delay (Note 4)	Driving Low, C _{LOAD} = 3 nF, V _{CCP} = 12 V	-	20	-	ns

LOW SIDE DRIVER

R _{H_BG} Output Resistance, Sourcing	SW = GND	-	TBD	4.2	Ω
R _{L_BG} Output Resistance, Sinking	SW = V _{CC}	-	TBD	2.2	Ω
T _{rDRVH} Transition Time	C _{LOAD} = 3 nF	-	16	-	ns
T _{fDRVH} Transition Time	C _{LOAD} = 3 nF	-	11	-	ns
T _{pdhDRVH} Propagation Delay (Note 4)	Driving High, C _{LOAD} = 3 nF, V _{CCP} = 12 V	-	20	-	ns
T _{pdhDRVH} Propagation Delay (Note 4)	Driving Low, C _{LOAD} = 3 nF, V _{CCP} = 12 V	-	20	-	ns
V _{NCDT} Negative Current Detector Threshold	(Note 3)	-	-1.0	-	mV

THERMAL SHUTDOWN

T _{sd} Thermal Shutdown (Note 3)		150	170	-	°C
T _{sdhys} Thermal Shutdown Hysteresis (Note 3)		-	20	-	°C

VRM 11 DAC

System Voltage Accuracy	1.0 V < DAC < 1.6 V	-	-	±0.5	%
	0.8 V < DAC < 1.0 V	-	-	±5.0	mV
	0.5 V < DAC < 0.8 V	-	-	±8.0	mV

3. Design guaranteed.
4. For propagation delays, “tpdh” refers to the specified signal going high “tpdl” refers to it going low. Reference Gate Timing Diagram.
5. Guaranteed by design; not tested in production.
6. Internal DAC voltage is centered 19 mV below the listed Voltage. For VR11.1/VR11.0/VR10
7. No DAC offset is implemented for AMD operation.

NCP5395

Table 2. VRM11 V_{ID} CODES

V _{ID7} 800 mV	V _{ID6} 400 mV	V _{ID5} 200 mV	V _{ID4} 100 mV	V _{ID3} 50 mV	V _{ID2} 25 mV	V _{ID1} 12.5 mV	V _{ID0} 6.25 mV	Voltage (V)	HEX
0	0	0	0	0	0	0	0		00
0	0	0	0	0	0	0	1		01
0	0	0	0	0	0	1	0	1.60000	02
0	0	0	0	0	0	1	1	1.59375	03
0	0	0	0	0	1	0	0	1.58750	04
0	0	0	0	0	1	0	1	1.58125	05
0	0	0	0	0	1	1	0	1.57500	06
0	0	0	0	0	1	1	1	1.56875	07
0	0	0	0	1	0	0	0	1.56250	08
0	0	0	0	1	0	0	1	1.55625	09
0	0	0	0	1	0	1	0	1.55000	0A
0	0	0	0	1	0	1	1	1.54375	0B
0	0	0	0	1	1	0	0	1.53750	0C
0	0	0	0	1	1	0	1	1.53125	0D
0	0	0	0	1	1	1	0	1.52500	0E
0	0	0	0	1	1	1	1	1.51875	0F
0	0	0	1	0	0	0	0	1.51250	10
0	0	0	1	0	0	0	1	1.50625	11
0	0	0	1	0	0	1	0	1.50000	12
0	0	0	1	0	0	1	1	1.49375	13
0	0	0	1	0	1	0	0	1.48750	14
0	0	0	1	0	1	0	1	1.48125	15
0	0	0	1	0	1	1	0	1.47500	16
0	0	0	1	0	1	1	1	1.46875	17
0	0	0	1	1	0	0	0	1.46250	18
0	0	0	1	1	0	0	1	1.45625	19
0	0	0	1	1	0	1	0	1.45000	1A
0	0	0	1	1	0	1	1	1.44375	1B
0	0	0	1	1	1	0	0	1.43750	1C
0	0	0	1	1	1	0	1	1.43125	1D
0	0	0	1	1	1	1	0	1.42500	1E
0	0	0	1	1	1	1	1	1.41875	1F
0	0	1	0	0	0	0	0	1.41250	20
0	0	1	0	0	0	0	1	1.40625	21
0	0	1	0	0	0	1	0	1.40000	22
0	0	1	0	0	0	1	1	1.39375	23
0	0	1	0	0	1	0	0	1.38750	24
0	0	1	0	0	1	0	1	1.38125	25
0	0	1	0	0	1	1	0	1.37500	26
0	0	1	0	0	1	1	1	1.36875	27
0	0	1	0	1	0	0	0	1.36250	28
0	0	1	0	1	0	0	1	1.35625	29
0	0	1	0	1	0	1	0	1.35000	2A
0	0	1	0	1	0	1	1	1.34375	2B
0	0	1	0	1	1	0	0	1.33750	2C
0	0	1	0	1	1	0	1	1.33125	2D

NCP5395

Table 2. VRM11 V_{ID} CODES

V _{ID7} 800 mV	V _{ID6} 400 mV	V _{ID5} 200 mV	V _{ID4} 100 mV	V _{ID3} 50 mV	V _{ID2} 25 mV	V _{ID1} 12.5 mV	V _{ID0} 6.25 mV	Voltage (V)	HEX
0	0	1	0	1	1	1	0	1.32500	2E
0	0	1	0	1	1	1	1	1.31875	2F
0	0	1	1	0	0	0	0	1.31250	30
0	0	1	1	0	0	0	1	1.30625	31
0	0	1	1	0	0	1	0	1.30000	32
0	0	1	1	0	0	1	1	1.29375	33
0	0	1	1	0	1	0	0	1.28750	34
0	0	1	1	0	1	0	1	1.28125	35
0	0	1	1	0	1	1	0	1.27500	36
0	0	1	1	0	1	1	1	1.26875	37
0	0	1	1	1	0	0	0	1.26250	38
0	0	1	1	1	0	0	1	1.25625	39
0	0	1	1	1	0	1	0	1.25000	3A
0	0	1	1	1	0	1	1	1.24375	3B
0	0	1	1	1	1	0	0	1.23750	3C
0	0	1	1	1	1	0	1	1.23125	3D
0	0	1	1	1	1	1	0	1.22500	3E
0	0	1	1	1	1	1	1	1.21875	3F
0	1	0	0	0	0	0	0	1.21250	40
0	1	0	0	0	0	0	1	1.20625	41
0	1	0	0	0	0	1	0	1.20000	42
0	1	0	0	0	0	1	1	1.19375	43
0	1	0	0	0	1	0	0	1.18750	44
0	1	0	0	0	1	0	1	1.18125	45
0	1	0	0	0	1	1	0	1.17500	46
0	1	0	0	0	1	1	1	1.16875	47
0	1	0	0	1	0	0	0	1.16250	48
0	1	0	0	1	0	0	1	1.15625	49
0	1	0	0	1	0	1	0	1.15000	4A
0	1	0	0	1	0	1	1	1.14375	4B
0	1	0	0	1	1	0	0	1.13750	4C
0	1	0	0	1	1	0	1	1.13125	4D
0	1	0	0	1	1	1	0	1.12500	4E
0	1	0	0	1	1	1	1	1.11875	4F
0	1	0	1	0	0	0	0	1.11250	50
0	1	0	1	0	0	0	1	1.10625	51
0	1	0	1	0	0	1	0	1.10000	52
0	1	0	1	0	0	1	1	1.09375	53
0	1	0	1	0	1	0	0	1.08750	54
0	1	0	1	0	1	0	1	1.08125	55
0	1	0	1	0	1	1	0	1.07500	56
0	1	0	1	0	1	1	1	1.06875	57
0	1	0	1	1	0	0	0	1.06250	58
0	1	0	1	1	0	0	1	1.05625	59
0	1	0	1	1	0	1	0	1.05000	5A
0	1	0	1	1	0	1	1	1.04375	5B

NCP5395

Table 2. VRM11 V_{ID} CODES

V _{ID7} 800 mV	V _{ID6} 400 mV	V _{ID5} 200 mV	V _{ID4} 100 mV	V _{ID3} 50 mV	V _{ID2} 25 mV	V _{ID1} 12.5 mV	V _{ID0} 6.25 mV	Voltage (V)	HEX
0	1	0	1	1	1	0	0	1.03750	5C
0	1	0	1	1	1	0	1	1.03125	5D
0	1	0	1	1	1	1	0	1.02500	5E
0	1	0	1	1	1	1	1	1.01875	5F
0	1	1	0	0	0	0	0	1.01250	60
0	1	1	0	0	0	0	1	1.00625	61
0	1	1	0	0	0	1	0	1.00000	62
0	1	1	0	0	0	1	1	0.99375	63
0	1	1	0	0	1	0	0	0.98750	64
0	1	1	0	0	1	0	1	0.98125	65
0	1	1	0	0	1	1	0	0.97500	66
0	1	1	0	0	1	1	1	0.96875	67
0	1	1	0	1	0	0	0	0.96250	68
0	1	1	0	1	0	0	1	0.95625	69
0	1	1	0	1	0	1	0	0.95000	6A
0	1	1	0	1	0	1	1	0.94375	6B
0	1	1	0	1	1	0	0	0.93750	6C
0	1	1	0	1	1	0	1	0.93125	6D
0	1	1	0	1	1	1	0	0.92500	6E
0	1	1	0	1	1	1	1	0.91875	6F
0	1	1	1	0	0	0	0	0.91250	70
0	1	1	1	0	0	0	1	0.90625	71
0	1	1	1	0	0	1	0	0.90000	72
0	1	1	1	0	0	1	1	0.89375	73
0	1	1	1	0	1	0	0	0.88750	74
0	1	1	1	0	1	0	1	0.88125	75
0	1	1	1	0	1	1	0	0.87500	76
0	1	1	1	0	1	1	1	0.86875	77
0	1	1	1	1	0	0	0	0.86250	78
0	1	1	1	1	0	0	1	0.85625	79
0	1	1	1	1	0	1	0	0.85000	7A
0	1	1	1	1	0	1	1	0.84375	7B
0	1	1	1	1	1	0	0	0.83750	7C
0	1	1	1	1	1	0	1	0.83125	7D
0	1	1	1	1	1	1	0	0.82500	7E
0	1	1	1	1	1	1	1	0.81875	7F
1	0	0	0	0	0	0	0	0.81250	80
1	0	0	0	0	0	0	1	0.80625	81
1	0	0	0	0	0	1	0	0.80000	82
1	0	0	0	0	0	1	1	0.79375	83
1	0	0	0	0	1	0	0	0.78750	84
1	0	0	0	0	1	0	1	0.78125	85
1	0	0	0	0	1	1	0	0.77500	86
1	0	0	0	0	1	1	1	0.76875	87
1	0	0	0	1	0	0	0	0.76250	88
1	0	0	0	1	0	0	1	0.75625	89

NCP5395

Table 2. VRM11 V_{ID} CODES

V _{ID7} 800 mV	V _{ID6} 400 mV	V _{ID5} 200 mV	V _{ID4} 100 mV	V _{ID3} 50 mV	V _{ID2} 25 mV	V _{ID1} 12.5 mV	V _{ID0} 6.25 mV	Voltage (V)	HEX
1	0	0	0	1	0	1	0	0.75000	8A
1	0	0	0	1	0	1	1	0.74375	8B
1	0	0	0	1	1	0	0	0.73750	8C
1	0	0	0	1	1	0	1	0.73125	8D
1	0	0	0	1	1	1	0	0.72500	8E
1	0	0	0	1	1	1	1	0.71875	8F
1	0	0	1	0	0	0	0	0.71250	90
1	0	0	1	0	0	0	1	0.70625	91
1	0	0	1	0	0	1	0	0.70000	92
1	0	0	1	0	0	1	1	0.69375	93
1	0	0	1	0	1	0	0	0.68750	94
1	0	0	1	0	1	0	1	0.68125	95
1	0	0	1	0	1	1	0	0.67500	96
1	0	0	1	0	1	1	1	0.66875	97
1	0	0	1	1	0	0	0	0.66250	98
1	0	0	1	1	0	0	1	0.65625	99
1	0	0	1	1	0	1	0	0.65000	9A
1	0	0	1	1	0	1	1	0.64375	9B
1	0	0	1	1	1	0	0	0.63750	9C
1	0	0	1	1	1	0	1	0.63125	9D
1	0	0	1	1	1	1	0	0.62500	9E
1	0	0	1	1	1	1	1	0.61875	9F
1	0	1	0	0	0	0	0	0.61250	A0
1	0	1	0	0	0	0	1	0.60625	A1
1	0	1	0	0	0	1	0	0.60000	A2
1	0	1	0	0	0	1	1	0.59375	A3
1	0	1	0	0	1	0	0	0.58750	A4
1	0	1	0	0	1	0	1	0.58125	A5
1	0	1	0	0	1	1	0	0.57500	A6
1	0	1	0	0	1	1	1	0.56875	A7
1	0	1	0	1	0	0	0	0.56250	A8
1	0	1	0	1	0	0	1	0.55625	A9
1	0	1	0	1	0	1	0	0.55000	AA
1	0	1	0	1	0	1	1	0.54375	AB
1	0	1	0	1	1	0	0	0.53750	AC
1	0	1	0	1	1	0	1	0.53125	AD
1	0	1	0	1	1	1	0	0.52500	AE
1	0	1	0	1	1	1	1	0.51875	AF
1	0	1	1	0	0	0	0	0.51250	B0
1	0	1	1	0	0	0	1	0.50625	B1
1	0	1	1	0	0	1	0	0.50000	B2
1	1	1	1	1	1	1	0	OFF	FE
1	1	1	1	1	1	1	1	OFF	FF

NCP5395

Parameter	Test Condition	TYP	MAX	Units
VR10 DAC				
System Voltage Accuracy	1.0 V < DAC < 1.6 V 0. 83125 V < DAC < 1.0 V	– –	±0.5 ±5	% mV

8. Internal DAC voltage is centered 19 mV below the listed Voltage. For VR11.1/VR11.0/VR10
No DAC offset is implemented for AMD operation.

V _{ID4} 400 mV	V _{ID3} 200 mV	V _{ID2} 100 mV	V _{ID1} 50 mV	V _{ID0} 25 mV	V _{ID5} 12.5 mV	V _{ID6} 6.25 mV	Voltage (V)
0	1	0	1	0	1	1	1.60000
0	1	0	1	0	1	0	1.59375
0	1	0	1	1	0	1	1.58750
0	1	0	1	1	0	0	1.58125
0	1	0	1	1	1	1	1.57500
0	1	0	1	1	1	0	1.56875
0	1	1	0	0	0	1	1.56250
0	1	1	0	0	0	0	1.55625
0	1	1	0	0	1	1	1.55000
0	1	1	0	0	1	0	1.54375
0	1	1	0	1	0	1	1.53750
0	1	1	0	1	0	0	1.53125
0	1	1	0	1	1	1	1.52500
0	1	1	0	1	1	0	1.51875
0	1	1	1	0	0	1	1.51250
0	1	1	1	0	0	0	1.50625
0	1	1	1	0	1	1	1.50000
0	1	1	1	0	1	0	1.49375
0	1	1	1	1	0	1	1.48750
0	1	1	1	1	0	0	1.48125
0	1	1	1	1	1	1	1.47500
0	1	1	1	1	1	0	1.46875
1	0	0	0	0	0	1	1.46250
1	0	0	0	0	0	0	1.45625
1	0	0	0	0	1	1	1.45000
1	0	0	0	0	1	0	1.44375
1	0	0	0	1	0	1	1.43750
1	0	0	0	1	0	0	1.43125
1	0	0	0	1	1	1	1.42500
1	0	0	0	1	1	0	1.41875
1	0	0	1	0	0	1	1.41250
1	0	0	1	0	0	0	1.40625
1	0	0	1	0	1	1	1.40000
1	0	0	1	0	1	0	1.39375
1	0	0	1	1	0	1	1.38750
1	0	0	1	1	0	0	1.38125
1	0	0	1	1	1	1	1.37500
1	0	0	1	1	1	0	1.36875
1	0	1	0	0	0	1	1.36250

NCP5395

Table 3. DAC CODES FOR VRM 10

V _{ID4} 400 mV	V _{ID3} 200 mV	V _{ID2} 100 mV	V _{ID1} 50 mV	V _{ID0} 25 mV	V _{ID5} 12.5 mV	V _{ID6} 6.25 mV	Voltage (V)
1	0	1	0	0	0	0	1.35625
1	0	1	0	0	1	1	1.35000
1	0	1	0	0	1	0	1.34375
1	0	1	0	1	0	1	1.33750
1	0	1	0	1	0	0	1.33125
1	0	1	0	1	1	1	1.32500
1	0	1	0	1	1	0	1.31875
1	0	1	1	0	0	1	1.31250
1	0	1	1	0	0	0	1.30625
1	0	1	1	0	1	1	1.30000
1	0	1	1	0	1	0	1.29375
1	0	1	1	1	0	1	1.28750
1	0	1	1	1	0	0	1.28125
1	0	1	1	1	1	1	1.27500
1	0	1	1	1	1	0	1.26875
1	1	0	0	0	0	1	1.26250
1	1	0	0	0	0	0	1.25625
1	1	0	0	0	1	1	1.25000
1	1	0	0	0	1	0	1.24375
1	1	0	0	1	0	1	1.23750
1	1	0	0	1	0	0	1.23125
1	1	0	0	1	1	1	1.22500
1	1	0	0	1	1	0	1.21875
1	1	0	1	0	0	1	1.21250
1	1	0	1	0	0	0	1.20625
1	1	0	1	0	1	1	1.20000
1	1	0	1	0	1	0	1.19375
1	1	0	1	1	0	1	1.18750
1	1	0	1	1	0	0	1.18125
1	1	0	1	1	1	1	1.17500
1	1	0	1	1	1	0	1.16875
1	1	1	0	0	0	1	1.16250
1	1	1	0	0	0	0	1.15625
1	1	1	0	0	1	1	1.15000
1	1	1	0	0	1	0	1.14375
1	1	1	0	1	0	1	1.13750
1	1	1	0	1	0	0	1.13125
1	1	1	0	1	1	1	1.12500
1	1	1	0	1	1	0	1.11875
1	1	1	1	0	0	1	1.11250
1	1	1	1	0	0	0	1.10625
1	1	1	1	0	1	1	1.10000
1	1	1	1	0	1	0	1.09375
1	1	1	1	1	0	1	OFF
1	1	1	1	1	0	0	OFF

NCP5395

Table 3. DAC CODES FOR VRM 10

V _{ID4} 400 mV	V _{ID3} 200 mV	V _{ID2} 100 mV	V _{ID1} 50 mV	V _{ID0} 25 mV	V _{ID5} 12.5 mV	V _{ID6} 6.25 mV	Voltage (V)
1	1	1	1	1	1	1	OFF
1	1	1	1	1	1	0	OFF
0	0	0	0	0	0	1	1.08750
0	0	0	0	0	0	0	1.08125
0	0	0	0	0	1	1	1.07500
0	0	0	0	0	1	0	1.06875
0	0	0	0	1	0	1	1.06250
0	0	0	0	1	0	0	1.05625
0	0	0	0	1	1	1	1.05000
0	0	0	0	1	1	0	1.04375
0	0	0	1	0	0	1	1.03750
0	0	0	1	0	0	0	1.03125
0	0	0	1	0	1	1	1.02500
0	0	0	1	0	1	0	1.01875
0	0	0	1	1	0	1	1.01250
0	0	0	1	1	0	0	1.00625
0	0	0	1	1	1	1	1.00000
0	0	0	1	1	1	0	0.99375
0	0	1	0	0	0	1	0.98750
0	0	1	0	0	0	0	0.98125
0	0	1	0	0	1	1	0.97500
0	0	1	0	0	1	0	0.96875
0	0	1	0	1	0	1	0.96250
0	0	1	0	1	0	0	0.95625
0	0	1	0	1	1	1	0.95000
0	0	1	0	1	1	0	0.94375
0	0	1	1	0	0	1	0.93750
0	0	1	1	0	0	0	0.93125
0	0	1	1	0	1	1	0.92500
0	0	1	1	0	1	0	0.91875
0	0	1	1	1	0	1	0.91250
0	0	1	1	1	0	0	0.90625
0	0	1	1	1	1	1	0.90000
0	0	1	1	1	1	0	0.89375
0	1	0	0	0	0	1	0.88750
0	1	0	0	0	0	0	0.88125
0	1	0	0	0	1	1	0.87500
0	1	0	0	0	1	0	0.86875
0	1	0	0	1	0	1	0.86250
0	1	0	0	1	0	0	0.85625
0	1	0	0	1	1	1	0.85000
0	1	0	0	1	1	0	0.84375
0	1	0	1	0	0	1	0.83750
0	1	0	1	0	0	0	0.83125

NCP5395

Parameter	Test Condition	MIN	TYP	MAX	Units
AMD DAC					
System Voltage Accuracy	1.0 V < DAC < 1.55V	-	-	±0.5	%
	0.6 V ≤ DAC < 1.0V	-	-	±1.0	%
	0.375 V < DAC < 0.6V	-	-	±2.0	%

9. NOTE: No DAC offset is implemented for AMD operation. DAC should be equal to the Nominal V_{out} shown in the table.

Table 4. AMD PROCESSOR 6-BIT V_{ID} CODE

(V_{ID}) Codes						Nominal V_{out}	Units
V_{ID5}	V_{ID4}	V_{ID3}	V_{ID2}	V_{ID1}	V_{ID0}		
0	0	0	0	0	0	1.550	V
0	0	0	0	0	1	1.525	V
0	0	0	0	1	0	1.500	V
0	0	0	0	1	1	1.475	V
0	0	0	1	0	0	1.450	V
0	0	0	1	0	1	1.425	V
0	0	0	1	1	0	1.400	V
0	0	0	1	1	1	1.375	V
0	0	1	0	0	0	1.350	V
0	0	1	0	0	1	1.325	V
0	0	1	0	1	0	1.300	V
0	0	1	0	1	1	1.275	V
0	0	1	1	0	0	1.250	V
0	0	1	1	0	1	1.225	V
0	0	1	1	1	0	1.200	V
0	0	1	1	1	1	1.175	V
0	1	0	0	0	0	1.150	V
0	1	0	0	0	1	1.125	V
0	1	0	0	1	0	1.100	V
0	1	0	0	1	1	1.075	V
0	1	0	1	0	0	1.050	V
0	1	0	1	0	1	1.025	V
0	1	0	1	1	0	1.000	V
0	1	0	1	1	1	0.975	V
0	1	1	0	0	0	0.950	V
0	1	1	0	0	1	0.925	V
0	1	1	0	1	0	0.900	V
0	1	1	0	1	1	0.875	V
0	1	1	1	0	0	0.850	V
0	1	1	1	0	1	0.825	V
0	1	1	1	1	0	0.800	V
0	1	1	1	1	1	0.775	V
1	0	0	0	0	0	0.7625	V
1	0	0	0	0	1	0.7500	V

NCP5395

Table 4. AMD PROCESSOR 6-BIT V_{ID} CODE

(V _{ID}) Codes						Nominal V _{out}	Units
V _{ID5}	V _{ID4}	V _{ID3}	V _{ID2}	V _{ID1}	V _{ID0}		
1	0	0	0	1	0	0.7375	V
1	0	0	0	1	1	0.7250	V
1	0	0	1	0	0	0.7125	V
1	0	0	1	0	1	0.7000	V
1	0	0	1	1	0	0.6875	V
1	0	0	1	1	1	0.6750	V
1	0	1	0	0	0	0.6625	V
1	0	1	0	0	1	0.6500	V
1	0	1	0	1	0	0.6375	V
1	0	1	0	1	1	0.6250	V
1	0	1	1	0	0	0.6125	V
1	0	1	1	0	1	0.6000	V
1	0	1	1	1	0	0.5875	V
1	0	1	1	1	1	0.5750	V
1	1	0	0	0	0	0.5625	V
1	1	0	0	0	1	0.5500	V
1	1	0	0	1	0	0.5375	V
1	1	0	0	1	1	0.5250	V
1	1	0	1	0	0	0.5125	V
1	1	0	1	0	1	0.5000	V
1	1	0	1	1	0	0.4875	V
1	1	0	1	1	1	0.4750	V
1	1	1	0	0	0	0.4625	V
1	1	1	0	0	1	0.4500	V
1	1	1	0	1	0	0.4375	V
1	1	1	0	1	1	0.4250	V
1	1	1	1	0	0	0.4125	V
1	1	1	1	0	1	0.4000	V
1	1	1	1	1	0	0.3875	V
1	1	1	1	1	1	0.3750	V

FUNCTIONAL DESCRIPTIONS

General

The NCP5395 dual edge modulated multiphase PWM controller is specifically designed with the necessary features for a high current CPU system. The IC consists of the following blocks: Precision Flexible DAC, Differential Remote Voltage Sense Amplifier, High Performance Voltage Error Amplifier, Differential Current Feedback Amplifiers, Precision Oscillator and Saw-tooth Generator, and PWM Comparators with Hysteresis. The controller also supports power saving mode as per Intel VR11.1 by accurately monitoring the current and switching between multi-phase and single phase operations as requested by the microprocessor system. Protection features include: Undervoltage Lockout, Soft-Start, Overcurrent Protection, Overvoltage Protection, and Power Good Monitor.

Precision Programmable DAC

A precision flexible DAC is provided. The DAC will conform to 2 different specifications: AMD or VR11.1. The VID7/AMD pin is provided to determine which DAC specification will be used and which soft-start mode the part will use for power up. There are two soft-start modes. If VID7/AMD is above its threshold the device will soft-start and ramp directly to the DAC code present on the VID inputs. The following truth table describes the functionality:

VID7/AMD Pin	VID7	Enable Pin Mode	Soft Start Mode
Above AMD Threshold	Not active	AMD Thresholds	Ramp to VID
Below AMD Threshold	Active	VR11.1 Thresholds	Ramp to Vboot

VID INPUTS

VID0–VID7 control the target regulation voltage during normal operation. In AMD mode the VID capture is enabled just before soft start. In VR11 mode the VID capture is enabled at the end of the V_{BOOT} waiting period. If the VID is valid the DAC will track to it. If an invalid VID occurs it will be ignored for 10 μ s before the controller shuts down.

Remote Sense Amplifier

A high performance differential amplifier is provided to accurately sense the output voltage of the regulator. The non-inverting input should be connected to the regulator's output voltage. The inverting input should be connected to the return line of the regulator. Both connection points are intended to be at a remote point so that the most accurate reading of the output voltage can be obtained. The amplifier is configured in a very unique way. First, the gain of the amplifier is internally set to unity. Second, both the inverting and non-inverting inputs of the amplifier are summing nodes. The inverting input sums the output voltage return

voltage with the DAC voltage. The non-inverting input sums the remote output voltage with a 1.3 V reference. The resulting voltage at the output of the remote sense amplifier is:

$$V_{\text{Diffout}} = V_{\text{out}} + 1.3 \text{ V} - V_{\text{dac}} - V_{\text{outreturn}}$$

This signal then goes through a standard compensation circuit and into the inverting input of the error amplifier. The non-inverting input of the error amplifier is also connected to the 1.3 V reference. The 1.3 V reference then is subtracted out and the error signal at the comp pin of the error amplifier is as normally expected:

$$V_{\text{comp}} = V_{\text{dac}} - V_{\text{out}}$$

The non-inverting input of the remote sense amplifier is pulled low through a small current sink during a fault condition to prevent accidental charging of the regulator output.

2/3/4 Phase Operation

The part can be configured to 2-, 3-, or 4-phase mode. In 2- or 3-phase mode, the internal drivers will be used. In 4-phase mode, an external driver must be used to drive phase 4. The NCP5359 driver is suggested to be used with the controller. The input to G4 pin will decide which phase mode the system is in operation. Please refer to the Application Schematics for more information.

High Performance Voltage Error Amplifier

A high performance voltage error amplifier is provided. The error amplifier's inverting input is VFB and its output is COMP. A standard type 3 compensation circuit is used to compensate the system. This involves a 3 pole, 2 zero compensation network. The comp pin is pulled to ground before soft-start for smooth start up.

Differential Current Sense

Four differential amplifiers are provided to sense the output current of each phase. These current sense amplifiers sense the current through the corresponding phase. A voltage is generated across a current sense element such as an inductor or sense resistor. The sense element should be between 0.5 m Ω and 1.5 m Ω . It is possible to sense both negative and positive going current. The information is used to create the signal CSSUM and provide feedback for current sharing.

Precision Oscillator

A programmable precision oscillator is provided. This oscillator is programmed by the summed resistance of an oscillator resistor and a current limit resistor. The output voltage of this pin is used as the reference for the current limit. The oscillator frequency range is 125 KHz/phase to 1000 KHz/phase. The oscillator frequency is proportional to the current drawn out of the OSC pin.

PWM Comparators

Four PWM comparators are incorporated within the IC. The non-inverting input of the comparators is connected to the output of the error amplifier. The inverting input is connected to a summed output of the phase current and the oscillator ramp voltage with an offset. The output of the comparator generates the PWM control signals.

During steady state operation, the duty cycle will center on the valley of the saw-tooth waveform. During a transient event, the controller will operate somewhat hysteretic, with the duty cycle climbing along either the down ramp, up ramp, or both.

Soft-Start

Soft-start is implemented internally. A digital counter steps the DAC up from zero to the target voltage based on the predetermined rate in the spec table. There are 2 possible soft start modes: VR11 and AMD. AMD mode simply ramps V_{core} from 0 V directly to the DAC setting. The VR11 mode ramps DAC to 1.1 V, pauses for 500 μ s, reads the DAC setting, then ramps to the final DAC setting.

Digital Slew Rate Limiter / Soft Start Block

The slew rate limiter and the soft-start block are to be implemented with a digital up/down counter controlled by an oscillator that is synchronized to VID line changes. During soft start the DAC will ramp at the soft-start rate, after soft start is complete the ramp rate will follow either the Intel or the AMD slew rate depending on the mode.

Under Voltage Lockouts

An under voltage circuit senses the V_{CC} input of the controller and the V_{CCP} input of the driver. During power up the input voltage to the controller is monitored. The PWM outputs and the soft start circuit are disabled until the input voltage exceeds the threshold voltage of the comparators. Hysteresis is incorporated within the comparators.

The DRVON is held low until V_{CCP} reaches the start threshold during startup. If V_{CCP} decreases below the stop threshold, the output gate will be forced low until input voltage V_{CCP} rises above the startup threshold.

Over Current Latch

A programmable over current latch is incorporated within the IC. The oscillator pin provides the reference voltage for this pin. A resistor divider from the OSC pin generates the ILIM voltage. The latch is set when the current information on V_{droop} exceeds the programmed voltage plus a 1.3 V offset. DRVON is immediately set low. To recover the part must be reset by the EN pin or by cycling V_{CC} .

UVLO Monitor

If the output voltage falls greater than 300 mV below the DAC voltage for more than 5 μ s the UVLO comparator will trip sending the VR_RDY signal low.

Over Voltage Protection

The output voltage is monitored at the input of the differential amplifier. During normal operation, if the output

voltage exceeds the DAC voltage by 185 mV, or 285 mV if in AMD mode, the VR_RDY flag will transition low the high side gate drivers set to low, and the low side gate drivers are all brought to high until the voltage falls below the OVP threshold. If the over voltage trip 8 times the output voltage will shut down. The OVP will not shut down the controller if it occurs during soft-start. This is to allow the controller to pull the output down to the DAC voltage and start up into a pre-charged output.

V_{CCP} Power ON Reset OVP

The V_{CCP} power on reset OVP feature is used to protect the CPU during start up. When V_{CCP} is higher than 3.2 V, the gate driver will monitor the switching node SW pin. If SWNx pin higher than 1.9 V, the bottom gate will be forced to high for discharge of the output capacitor. This works best if the 5 volt standby is diode OR'ed into V_{CCP} with the 12 V rail. The fault mode will be latched and the DRVON pin will be forced to low, unless V_{CCP} is reduced below the UVLO threshold.

Power Saving Mode

The controller is designed to allow power saving mode to maintain a maximum efficiency. When a low PSI signal from microcontroller is received, the controller will keep one phase operating while shedding other phases. The active one phase will operate in diode emulation mode, minimizing power losses in light load. When the low PSI signal is de-asserted, the dropped phases will be pulled back in to be ready for heavy load.

Adaptive Non-overlap

The non-overlap dead time control is used to avoid shoot through damage to the power MOSFETs. When the PWM signal pull high, DRVH will go low after a propagation delay, the controller monitors the switching node (SWN) pin voltage and the gate voltage of the MOSFET to know the status of the MOSFET. When the low side MOSFET status is off an internal timer will delay turn on of the high-side MOSFET. When the PWM pull low, gate DRVH will go low after the propagation delay (tpdDRVH). The time to turn off the high side MOSFET is depending on the total gate charge of the high-side MOSFET. A timer will be triggered once the high side MOSFET is turn off to delay the turn on the low-side MOSFET.

Layout Guidelines

Layout is very important thing for design a DC-DC converter. Bootstrap capacitor and V_{in} capacitor are most critical items, it should be placed as close as to the controller IC. Another item is using a GND plane. Ground plane can provide a good return path for gate drives for reducing the ground noise. Therefore GND pin should be directly connected to the ground plane and close to the low-side MOSFET source pin. Also, the gate drive trace should be considered. The gate drives has a high di/dt when switching, therefore a minimized gate drives trace can reduce the di/dv, raise and fall time for reduce the switching loss.

NCP5395

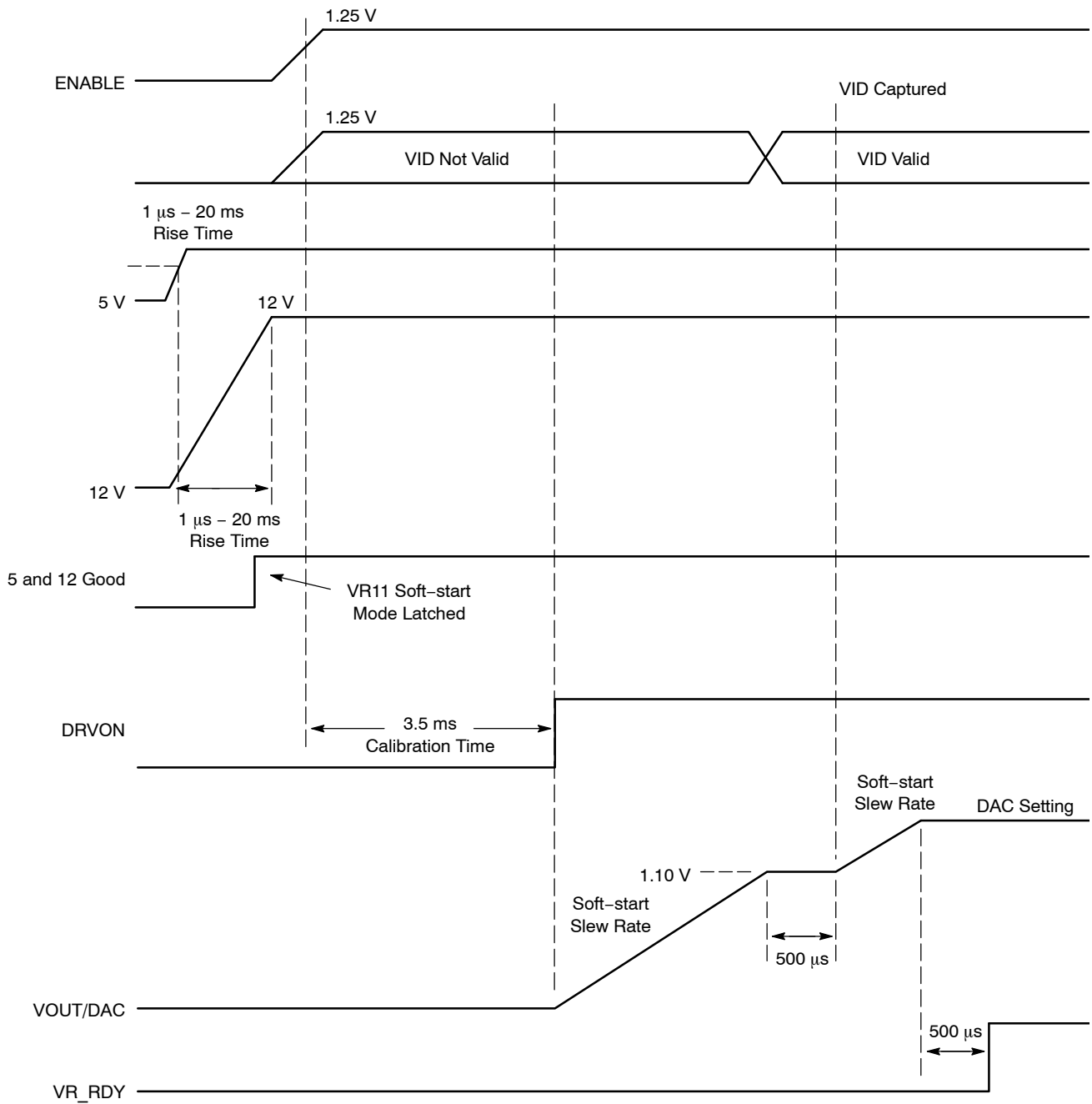

Figure 6. VR11.1 Start Up Timing Diagram

NCP5395

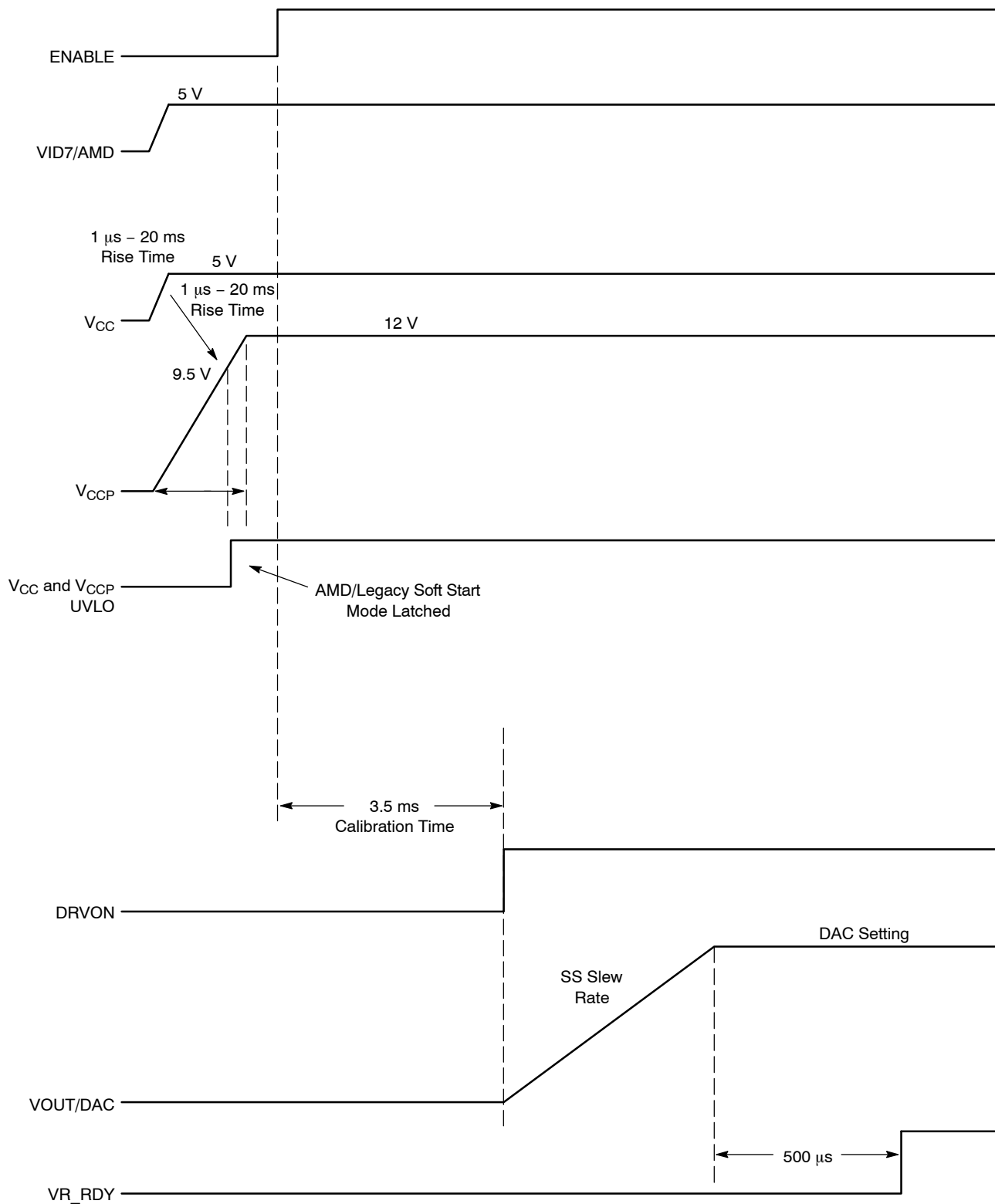
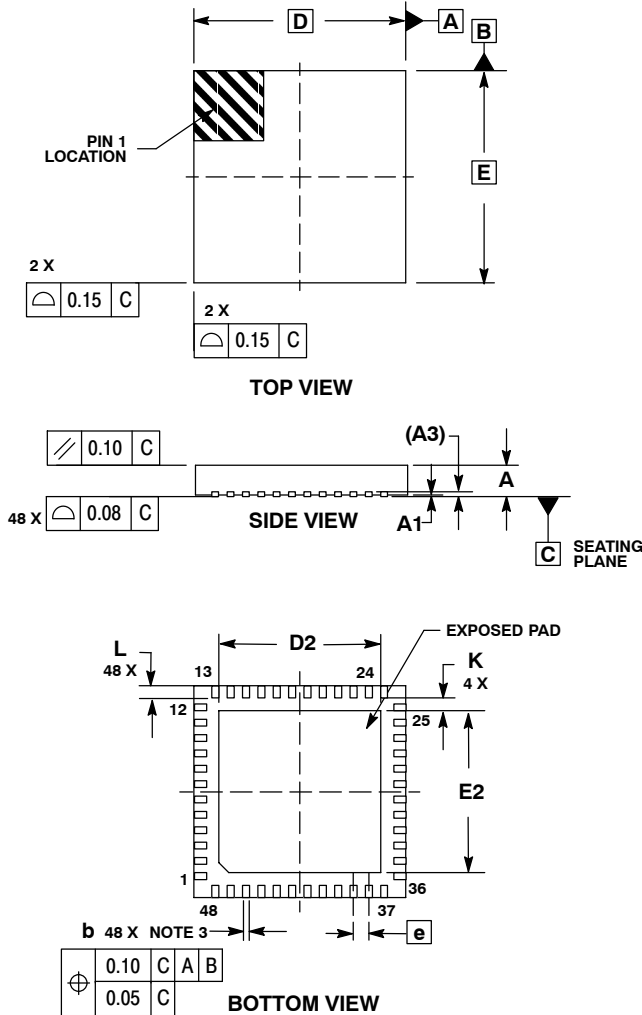

Figure 7. AMD / Legacy Start Up Timing Diagram

NCP5395

PACKAGE DIMENSIONS

QFN48
CASE 485K-02
ISSUE C



NOTES:

1. DIMENSIONS AND TOLERANCING PER ASME Y14.5M, 1994.
2. DIMENSIONS IN MILLIMETERS.
3. DIMENSION b APPLIES TO THE PLATED TERMINAL AND IS MEASURED BETWEEN 0.25 AND 0.30 MM FROM TERMINAL
4. COPLANARITY APPLIES TO THE EXPOSED PAD AS WELL AS THE TERMINALS.

DIM	MILLIMETERS		
	MIN	NOM	MAX
A	0.800	0.900	1.000
A1	0.000	0.025	0.050
A3	0.200 REF		
b	0.180	0.250	0.300
D	7.000 BSC		
D2	5.260	5.360	5.460
E	7.000 BSC		
E2	5.260	5.360	5.460
e	0.500 BSC		
K	0.200	----	----
L	0.300	0.400	0.500

The products described herein (NCP5395), may be covered by one or more of the following U.S. patents; US07057381. There may be other patents pending.

ON Semiconductor and **ON** are registered trademarks of Semiconductor Components Industries, LLC (SCILLC). SCILLC reserves the right to make changes without further notice to any products herein. SCILLC makes no warranty, representation or guarantee regarding the suitability of its products for any particular purpose, nor does SCILLC assume any liability arising out of the application or use of any product or circuit, and specifically disclaims any and all liability, including without limitation special, consequential or incidental damages. "Typical" parameters which may be provided in SCILLC data sheets and/or specifications can and do vary in different applications and actual performance may vary over time. All operating parameters, including "Typicals" must be validated for each customer application by customer's technical experts. SCILLC does not convey any license under its patent rights nor the rights of others. SCILLC products are not designed, intended, or authorized for use as components in systems intended for surgical implant into the body, or other applications intended to support or sustain life, or for any other application in which the failure of the SCILLC product could create a situation where personal injury or death may occur. Should Buyer purchase or use SCILLC products for any such unintended or unauthorized application, Buyer shall indemnify and hold SCILLC and its officers, employees, subsidiaries, affiliates, and distributors harmless against all claims, costs, damages, and expenses, and reasonable attorney fees arising out of, directly or indirectly, any claim of personal injury or death associated with such unintended or unauthorized use, even if such claim alleges that SCILLC was negligent regarding the design or manufacture of the part. SCILLC is an Equal Opportunity/Affirmative Action Employer. This literature is subject to all applicable copyright laws and is not for resale in any manner.

PUBLICATION ORDERING INFORMATION

LITERATURE FULFILLMENT:
Literature Distribution Center for ON Semiconductor
P.O. Box 5163, Denver, Colorado 80217 USA
Phone: 303-675-2175 or 800-344-3860 Toll Free USA/Canada
Fax: 303-675-2176 or 800-344-3867 Toll Free USA/Canada
Email: orderlit@onsemi.com

N. American Technical Support: 800-282-9855 Toll Free
USA/Canada
Europe, Middle East and Africa Technical Support:
Phone: 421 33 790 2910
Japan Customer Focus Center
Phone: 81-3-5773-3850

ON Semiconductor Website: www.onsemi.com
Order Literature: <http://www.onsemi.com/orderlit>

For additional information, please contact your local Sales Representative

Looking for pricing, stock, or lifecycle information?

Click below to explore more details on WIN SOURCE:

 [View NCP5395MNR2G on WIN SOURCE](#)

 [ON Semiconductor](#) Information

Optimize Your Supply Chain with WIN SOURCE Solutions

-  Global Sourcing Solution
-  Obsolete Management
-  Cost Control Management
-  Shortage Management
-  Alternative Solution
-  Excess Inventory Management