

Low Dropout Voltage Regulator with Reset

■ GENERAL DISCRIPTION

The NJM2800 is a low dropout voltage regulator with reset function.

It provides up to 150mA of logic supply, and the reset function monitors either input or output voltage of the regulator with 1% accuracy.

It is suitable for local power supply and reset for small micro controller and other logic chips.

■ PACKAGE OUTLINE

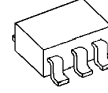

NJM2800F



NJM2800U/U1

■ FEATURES

- Output Voltage Accuracy $V_o = \pm 1.0\%$
- Reset Voltage Accuracy $V_{reset} = \pm 1.0\%$
- Reset Hold Time $t_d = 10\text{mS} \pm 1.0\text{mS}$
- Ripple Rejection 60dB typ. (f=1kHz)
- Quiescent Current $I_Q = 250\mu\text{A}$ (typ.)
- Input Voltage Monitor type
- Open Collector Output
- Internal Short Circuit Current Limit
- Internal Thermal Overload Protection
- Bipolar Technology
- Package Outline SOT89-5 (NJM2800U/U1), SOT-23-5(NJU2800F)

■ PIN CONFIGURATION

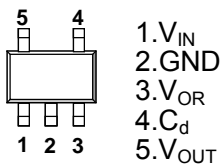

NJU2800F

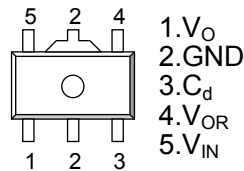

NJU2800U/U1

■ OUTPUT VOLTAGE/ DETECTION VOLTAGE

Device Name	Output Voltage	Detection Voltage
NJM2800F/U1803	1.8V	3.0V
NJM2800F/U1-2528	2.5V	2.8V
NJM2800U3342	3.3V	4.2V

■ EQUIVALENT CIRCUIT

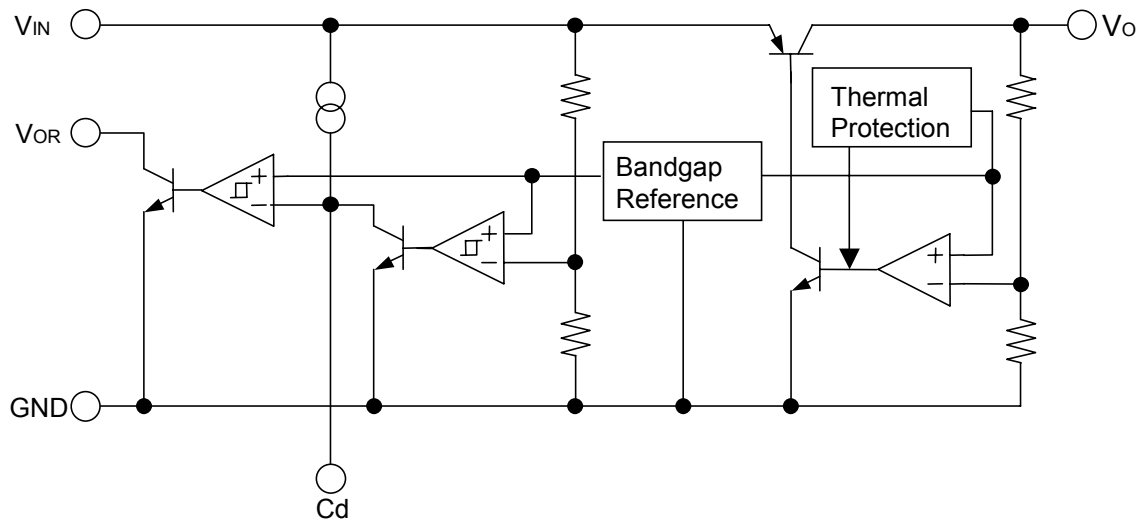

■ ABSOLUTE MAXIMUM RATINGS

(Ta=25°C)

PARAMETER	SYMBOL	RATINGS	UNIT
Input Voltage	V _{IN}	+14	V
Power Dissipation	P _D	200 (SOT-23-5)	mW
		350 (SOT-89-5)	
Operating Temperature	T _{opr}	-40~+85	°C
Storage Temperature	T _{stg}	-40~+125	°C

■ ELECTRICAL CHARACTERISTICS (V_{IN}=V_o+1V, C_{IN}=0.1μF, C_o=1μF (V_o≤2.6V: C_o=2.2μF) Ta=25°C)

PARAMETER	SYMBOL	TEST CONDITION	MIN.	TYP.	MAX.	UNIT
Quiescent Current	I _q	V _{IN} =V _o +2V, I _o =0mA	-	250	350	μA
Regulator Block						
Output Voltage	V _o	I _o =30mA	-1.0%	-	+1.0%	V
Output Current	I _o	V _o =0.3V	150	200	-	mA
Line Regulation	ΔV _o /ΔV _{IN}	V _{IN} =V _o +1V~V _o +6V, I _o =30mA	-	-	0.10	%/V
Load Regulation	ΔV _o /ΔI _o	I _o =0~100mA	-	-	0.03	%/mA
Dropout Voltage	ΔV _{L_O}	I _o =60mA	-	0.10	0.18	V
Ripple Rejection	RR	e _{in} =200mVrms, f=1kHz, I _o =10mA, V _o =3V	-	60	-	dB
Output Voltage Temperature Coefficient	ΔV _o /ΔT	Ta=0~85°C, I _o =10mA	-	±50	-	ppm/°C
Output Noise Voltage	V _{NO}	f=10Hz~100kHz, I _o =10mA, V _o =3V	-	45	-	μVrms
Reset Block						
Voltage Detection	V _{RT}	V _{IN} =H→L	-1.0%	-	+1.0%	V
Hysteresis Voltage	V _{RTH}	V _{IN} =H→L→H	V _{RT} ×3%	V _{RT} ×5%	V _{RT} ×8%	mV
Low Level Output Voltage	R _{ORL}	V _{IN} =V _{RT} -0.5V, R _L =100kΩ	-	100	300	mV
Output Leak Current	I _{ORH}	V _{IN} =V _{RT} +0.5V	-	-	0.1	μA
On time Output Current	I _{ORL}	V _{IN} =V _{RT} -0.5V, R _L =0Ω	5	-	-	mA
Reset Output Delay Time	t _d	V _{IN} =(V _{RT} -0.5V)→(V _{RT} +0.5V), C _d =0.1μF	9	10	11	mS
Operation Voltage Limit	V _{OPL}	V _{ORL} =0.4V	-	0.9	-	V

(note 1) The above specification is a common specification for all output voltages.

Therefore, it may be different from the individual specification for a specific output voltage.

■ TIMING CHART

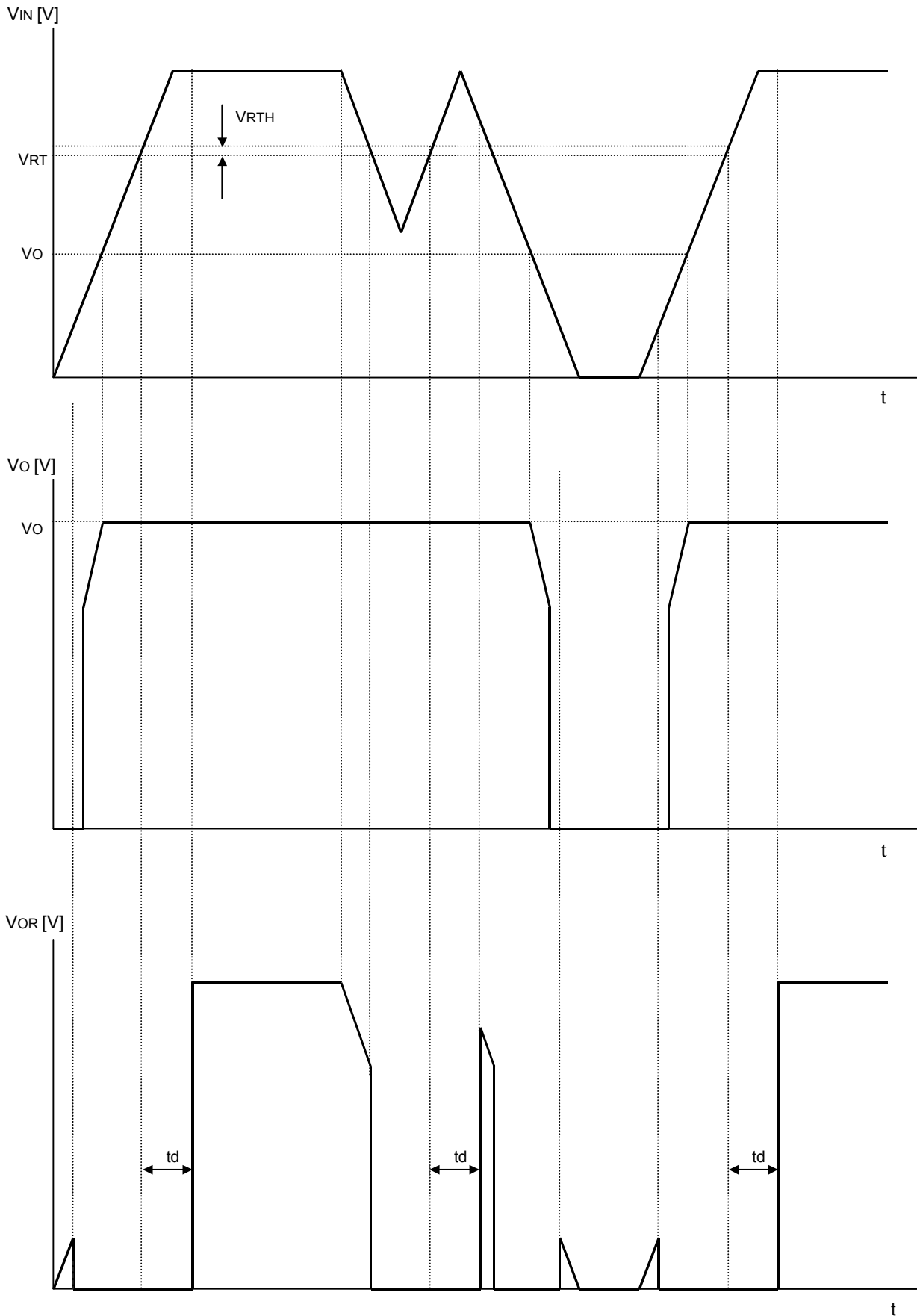

* V_{OR} is the case where a pull-up is carried out to V_{IN} through resistance.

■ TEST CIRCUIT

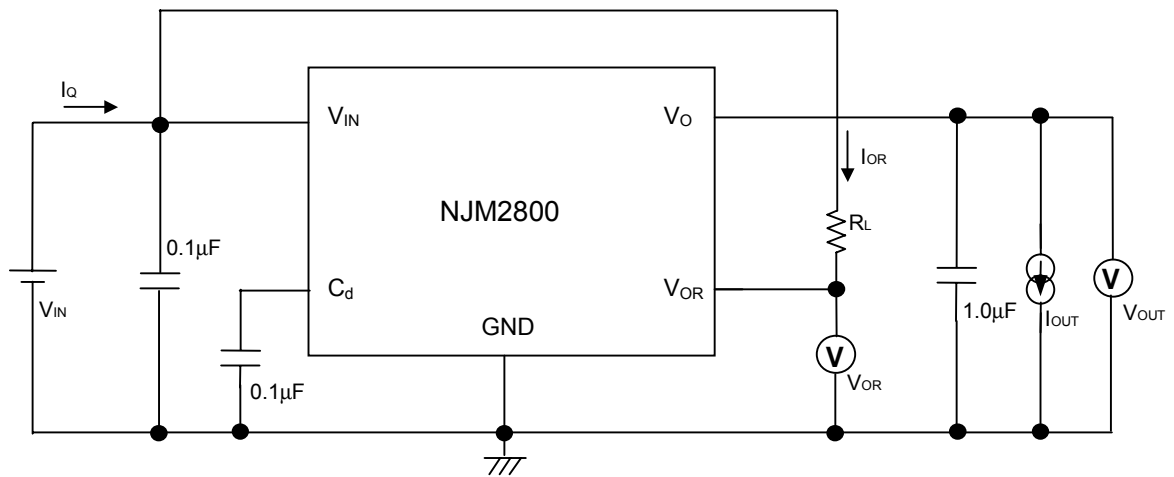

■ TYPICAL APPLICATIONS

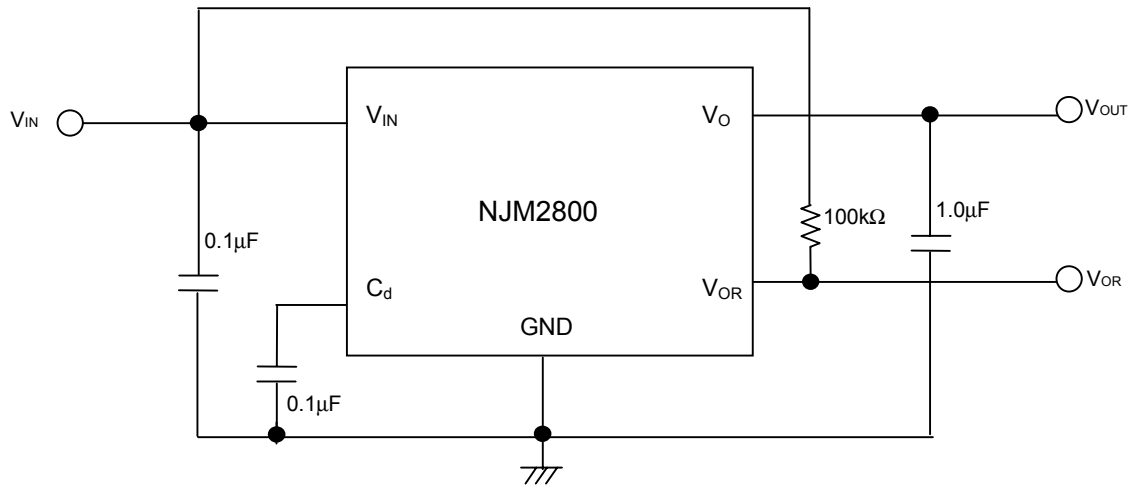

ELECTRICAL CHARACTERISTICS

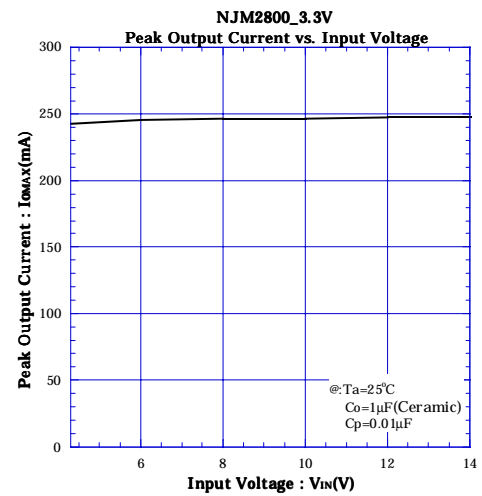
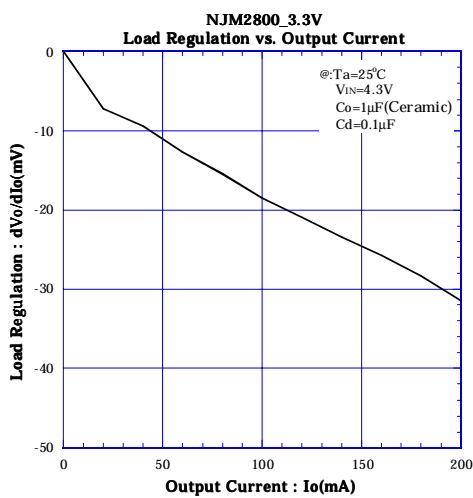
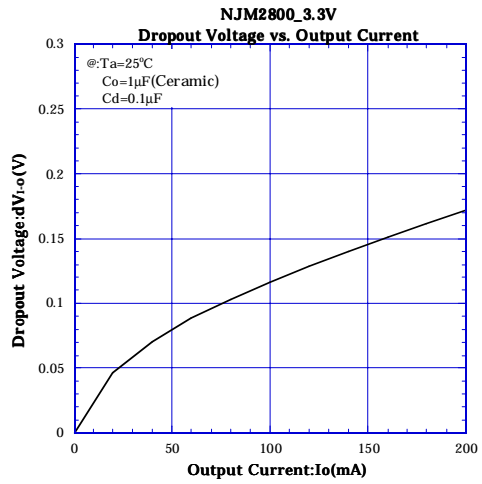
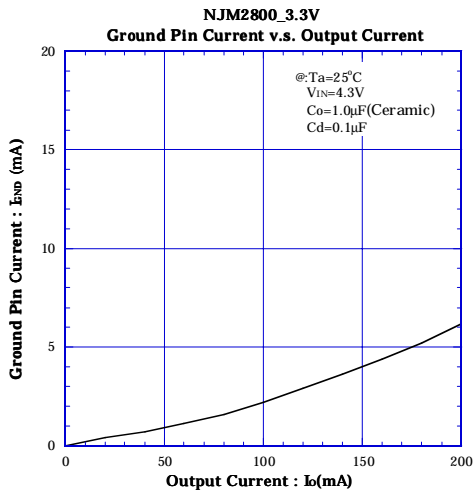
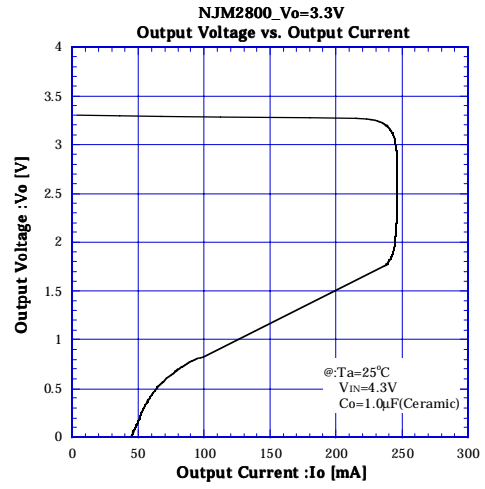
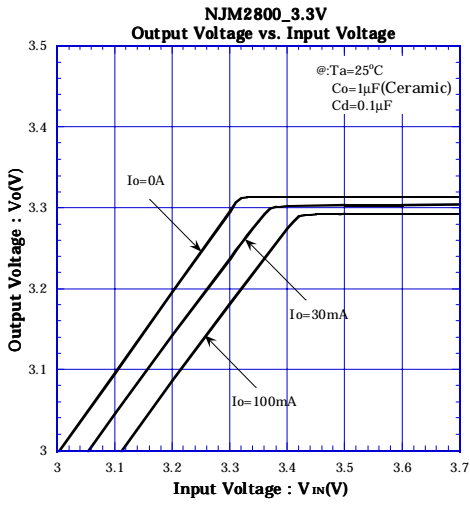

ELECTRICAL CHARACTERISTICS

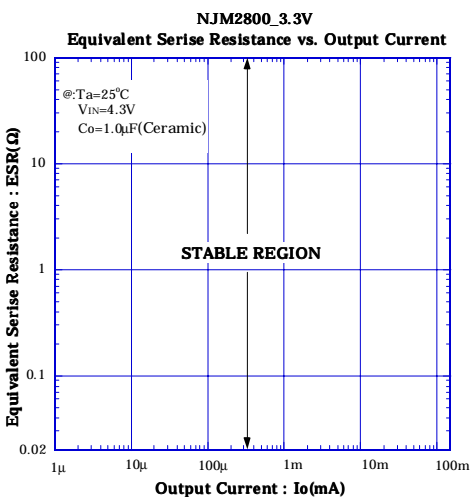
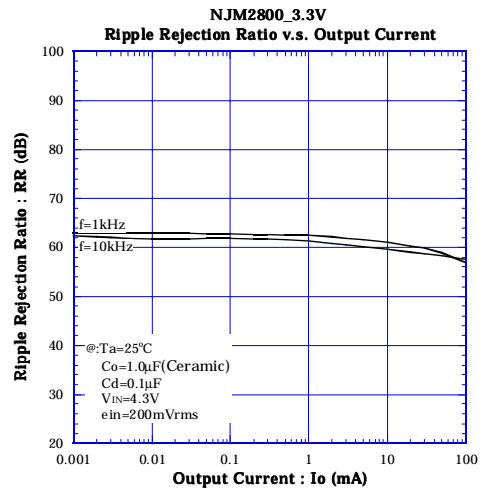
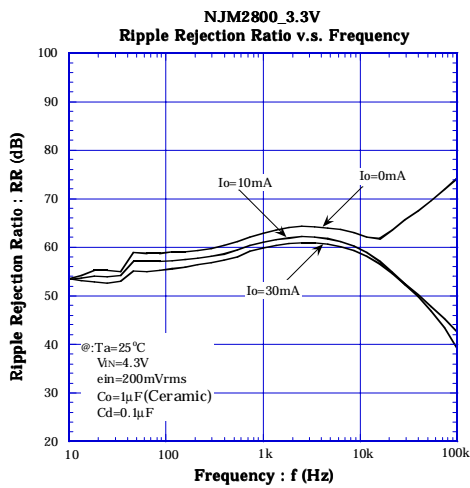
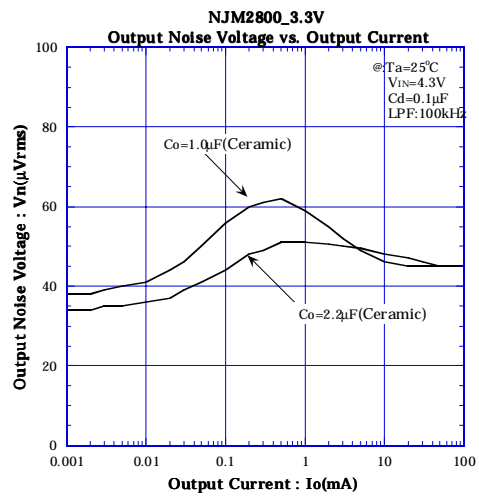
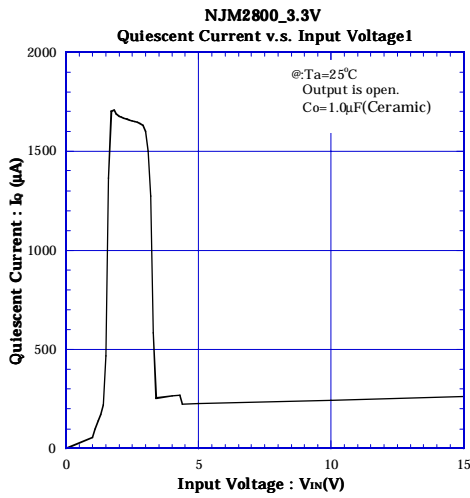

■ ELECTRICAL CHARACTERISTICS

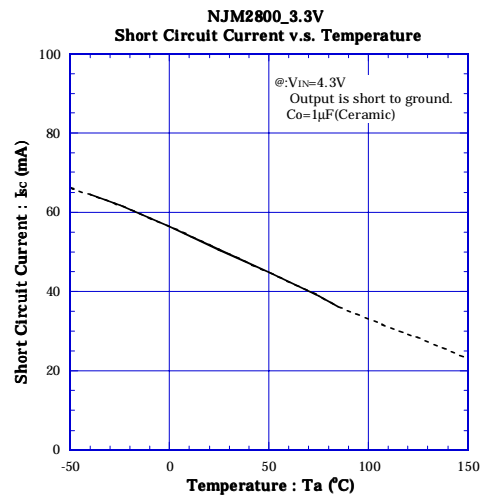
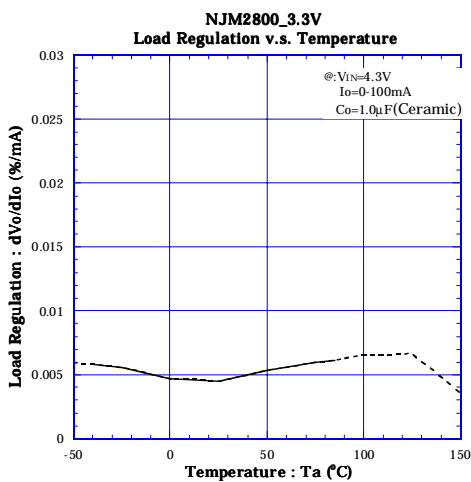
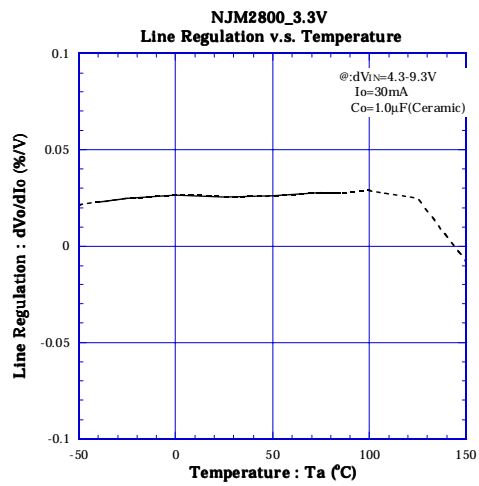
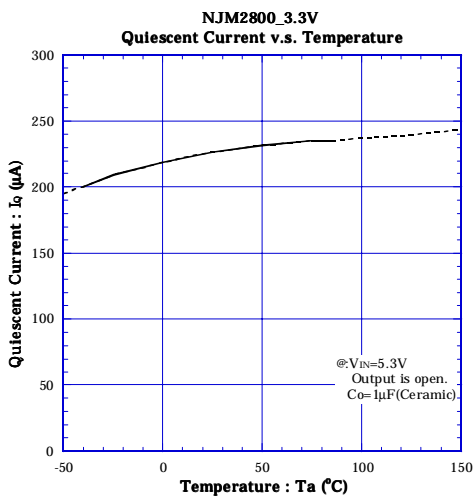
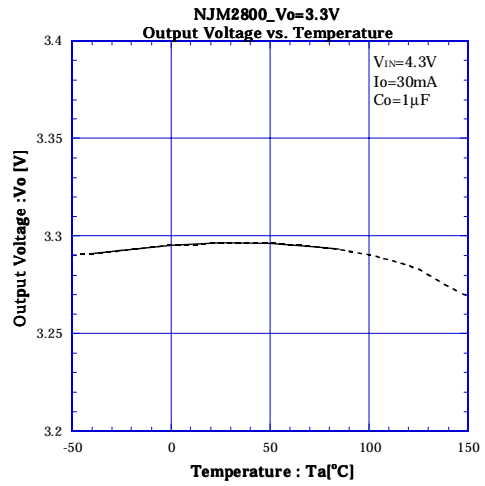
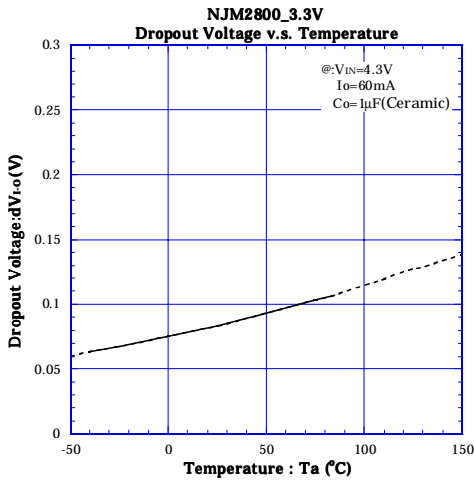



[CAUTION]

The specifications on this databook are only given for information, without any guarantee as regards either mistakes or omissions. The application circuits in this databook are described only to show representative usages of the product and not intended for the guarantee or permission of any right including the industrial rights.

Looking for pricing, stock, or lifecycle information?

Click below to explore more details on WIN SOURCE:

-  [View NJM2800U3342-TE1 on WIN SOURCE](#)
-  [NJR Corporation/NJRC Information](#)

Optimize Your Supply Chain with WIN SOURCE Solutions

-  Global Sourcing Solution
-  Obsolete Management
-  Cost Control Management
-  Shortage Management
-  Alternative Solution
-  Excess Inventory Management