

SUPER LOW OPERATING CURRENT AND LOW OFFSET VOLTAGE TINY SINGLE C-MOS OPERATIONAL AMPLIFIER

■ GENERAL DESCRIPTION

The NJU7006 is a super low operating current and low offset voltage tiny single C-MOS operational amplifier.

The input offset voltage is lower than 2mV (max) and the input bias current is as low as less than 1pA (typ),consequently the very small signal around the ground level can be amplified.

The operating current is 3μA (typ),and the output stage permits output signals to swing between both of the supply rails.

Furthermore, the NJU7006 is packaged with very small SOT-23-5,therefore it can be especially applied to battery operated portable items.

■ PACKAGE OUTLINE



NJU7006F

■ FEATURES

- Super Low Operating Current ($I_{DD}=3.0\mu A$ typ.)
- Single Power Supply ($V_{DD}=1.8\sim 3.6V$)
- Low Offset Voltage ($V_{IO}=2mV$ max.@ 3.0V)
- Wide Output Swing Range ($V_{OM}=2.9V$ min.@ 3.0V)
- Low Bias Current ($I_B=1pA$ typ.)
- Compensation Capacitor Incorporated
- Package Outline SOT-23-5
- C-MOS Technology

■ PIN CONFIGURATION

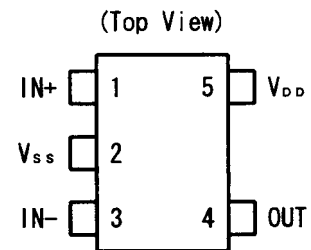

■ EQUIVALENT CIRCUIT

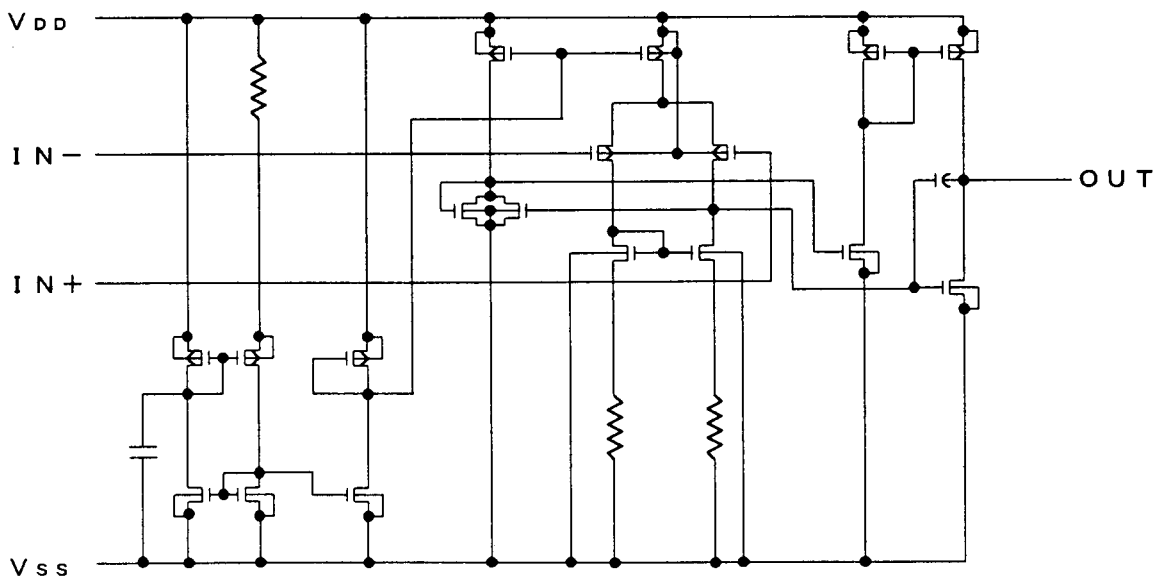

NJU7006

■ ABSOLUTE MAXIMUM RATINGS

(Ta=25°C)

PARAMETER	SYMBOL	RATINGS	UNIT
Supply Voltage	V _{IN}	7	V
Differential Input Voltage	V _{ID}	± 7 (note1)	V
Common Mode Input Voltage	V _{IC}	-0.3~7	V
Power Dissipation	P _D	200	mW
Operating Temperature Range	T _{opr}	-40~+85	°C
Storage Temperature Range	T _{stg}	-55~+125	°C

(note1) If the supply voltage (V_{DD}) is less than 7V, the input voltage must not over the V_{DD} level though 7V is limit specified.

(note2) Decoupling capacitor should be connected between V_{DD} and V_{SS} for the stable operation.

■ ELECTRICAL CHARACTERISTICS

(Ta=25°C, V_{DD}=3.0V, R_L=∞)

PARAMETER	SYMBOL	TEST CONDITION	MIN.	TYP.	MAX.	UNIT
Input Offset Voltage	V _{IO}	V _{IN} =1/2V _{DD}	-	-	2	mV
Input Offset Current	I _{IO}		-	1	-	pA
Input Bias Current	I _{IB}		-	1	-	pA
Input Impedance	R _{IN}		-	1	-	TΩ
Large Signal Voltage Gain	A _{VD}		60	70	-	dB
Input Common Mode Voltage Range	V _{ICM}		0~2.5	-	-	V
Maximum Output Swing Voltage	V _{OM1}	R _L =10MΩ	V _{DD} -0.1	-	-	V
	V _{OM2}	R _L =10MΩ	-	-	V _{SS} +0.1	V
Common Mode Rejection Ratio	CMR	V _{IN} =1/2V _{DD}	55	65	-	dB
Supply Voltage Rejection Ratio	SVR	V _{DD} =3.0~3.6V	60	70	-	dB
Operating Current	I _{DD}		-	3.0	4.5	μA
Slew Rate	SR	C _L =10pF	0.02	0.04	-	V/μs
Unity Gain Bandwidth	F _t	A _v =40dB, C _L =10pF	-	95	-	kHz

(note3) The source current is less than 0.29μA (at V_{OM}/R_L=2.9V/10MΩ).



(note4) The load capacitance (C_L) is less than 200pF.

[CAUTION]

The specifications on this databook are only given for information, without any guarantee as regards either mistakes or omissions. The application circuits in this databook are described only to show representative usages of the product and not intended for the guarantee or permission of any right including the industrial rights.

Looking for pricing, stock, or lifecycle information?

Click below to explore more details on WIN SOURCE:

-  [View NJU7006F-TE1 on WIN SOURCE](#)
-  [NJR Corporation/NJRC Information](#)

Optimize Your Supply Chain with WIN SOURCE Solutions

-  Global Sourcing Solution
-  Obsolete Management
-  Cost Control Management
-  Shortage Management
-  Alternative Solution
-  Excess Inventory Management