



**THE DATASHEET OF  
NLA54685FCT1G**



# NLAS4685

## Ultra-Low Resistance Dual SPDT Analog Switch

The NLAS4685 is an advanced CMOS analog switch fabricated in Sub-micron silicon gate CMOS technology. The device is a dual Independent Single Pole Double Throw (SPDT) switch featuring Ultra-Low  $R_{ON}$  of 0.8  $\Omega$ , for the Normally Closed (NC) switch and for the Normally Opened switch (NO) at 2.7 V.

The part also features guaranteed Break Before Make switching, assuring the switches never short the driver.

The NLAS4685 is available in a 2.0 x 1.5 mm bumped die array, with a 3 x 4 arrangement of solder bumps. The pitch of the solder bumps is 0.5 mm for easy handling.

### Features

- Ultra-Low  $R_{ON}$ , < 0.8  $\Omega$  at 2.7 V
- Threshold Adjusted to Function with 1.8 V Control at  $V_{CC} = 2.7\text{--}3.3$  V
- Single Supply Operation from 1.8–5.5 V
- Tiny 2 x 1.5 mm Bumped Die
- Low Crosstalk, < 81 dB at 100 kHz
- Full 0– $V_{CC}$  Signal Handling Capability
- High Isolation, –65 dB at 100 kHz
- Low Standby Current, < 50 nA
- Low Distortion, < 0.14% THD
- $R_{ON}$  Flatness of 0.15  $\Omega$
- Pin for Pin Replacement for MAX4685
- Pb-Free Package is Available

### Applications

- Cell Phone
- Speaker Switching
- Power Switching (Up to 100 mA)
- Modems
- Automotive



**ON Semiconductor®**

<http://onsemi.com>



A1  
Microbump-10  
CASE 489AA

### MARKING DIAGRAM

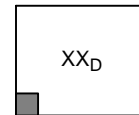

A1  
XX = Device Code  
D = Date Code

### PIN CONNECTIONS AND LOGIC DIAGRAM

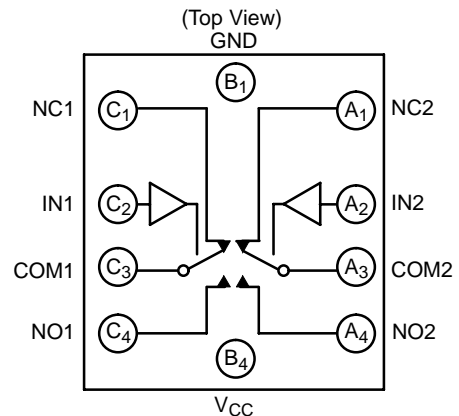

### FUNCTION TABLE

IN 1, 2	NO 1, 2	NC 1, 2
0	OFF	ON
1	ON	OFF

### ORDERING INFORMATION

Device	Package	Shipping†
NLAS4685FCT1	Microbump	3000 Tape/Reel
NLAS4685FCT1G	Microbump (Pb-Free)	3000 Tape/Reel

†For information on tape and reel specifications, including part orientation and tape sizes, please refer to our Tape and Reel Packaging Specification Brochure, BRD8011/D.

# NLAS4685

## MAXIMUM RATINGS

Symbol	Parameter	Value	Unit
V <sub>CC</sub>	Positive DC Supply Voltage	-0.5 to +7.0	V
V <sub>IS</sub>	Analog Input Voltage (V <sub>NO</sub> , V <sub>NC</sub> , or V <sub>COM</sub> ) (Note 1)	-0.5 ≤ V <sub>IS</sub> ≤ V <sub>CC</sub> + 0.5	V
V <sub>IN</sub>	Digital Select Input Voltage	-0.5 ≤ V <sub>I</sub> ≤ +7.0	V
I <sub>IK</sub>	DC Current, Into or Out of Any Pin	±50	mA

Maximum ratings are those values beyond which device damage can occur. Maximum ratings applied to the device are individual stress limit values (not normal operating conditions) and are not valid simultaneously. If these limits are exceeded, device functional operation is not implied, damage may occur and reliability may be affected.

1. Signal voltage on NC, NO, and COM exceeding V<sub>CC</sub> or GND are clamped by the internal diodes. Limit forward diode current to maximum current rating.

## RECOMMENDED OPERATING CONDITIONS

Symbol	Parameter	Min	Max	Unit
V <sub>CC</sub>	DC Supply Voltage	1.8	5.5	V
V <sub>IN</sub>	Digital Select Input Voltage	GND	5.5	V
V <sub>IS</sub>	Analog Input Voltage (NC, NO, COM)	GND	V <sub>CC</sub>	V
T <sub>A</sub>	Operating Temperature Range	-55	+125	°C
t <sub>r</sub> , t <sub>f</sub>	Input Rise or Fall Time, SELECT	V <sub>CC</sub> = 3.3 V ± 0.3 V V <sub>CC</sub> = 5.0 V ± 0.5 V	0 100 20	ns/V

## DC CHARACTERISTICS – Digital Section (Voltages Referenced to GND)

Symbol	Parameter	Condition	V <sub>CC</sub> ± 10%	Guaranteed Limit			Unit
				-55°C to 25°C	< 85°C	< 125°C	
V <sub>IH</sub>	Minimum High-Level Input Voltage, Select Inputs		2.0	1.4	1.4	1.4	V
			2.5	1.4	1.4	1.4	
			3.0	1.4	1.4	1.4	
			5.0	2.0	2.0	2.0	
V <sub>IL</sub>	Maximum Low-Level Input Voltage, Select Inputs		2.0	0.5	0.5	0.5	V
			2.5	0.5	0.5	0.5	
			3.0	0.5	0.5	0.5	
			5.0	0.8	0.8	0.8	
I <sub>IN</sub>	Maximum Input Leakage Current, Select Inputs	V <sub>IN</sub> = 5.5 V or GND	5.5	± 1.0	± 1.0	± 1.0	μA
I <sub>OFF</sub>	Power Off Leakage Current	V <sub>IN</sub> = 5.5 V or GND	0	± 10	± 10	± 10	μA
I <sub>CC</sub>	Maximum Quiescent Supply Current	Select and V <sub>IS</sub> = V <sub>CC</sub> or GND	5.5	± 180	± 200	± 200	nA

# NLAS4685

## DC ELECTRICAL CHARACTERISTICS – Analog Section

Symbol	Parameter	Condition	$V_{CC} \pm 10\%$	Guaranteed Maximum Limit						Unit
				-55°C to 25°C		< 85°C		< 125°C		
				Min	Max	Min	Max	Min	Max	
$R_{ON}$ (NC, NO)	"ON" Resistance (Note 2)	$V_{IN} \geq V_{IH}$ $V_{IS} = \text{GND to } V_{CC}$ $ I_{IN}  \leq 100 \text{ mA}$	2.5		2.0		2.0		2.0	$\Omega$
			3.0		0.8		0.8		1.0	
			5.0		0.8		0.8		0.9	
$R_{FLAT}$ (NC, NO)	On-Resistance Flatness (Notes 2, 4)	$I_{COM} = 100 \text{ mA}$ $V_{IS} = 0 \text{ to } V_{CC}$	2.5		0.35		0.35		0.35	$\Omega$
			3.0		0.35		0.35		0.35	
			5.0		0.35		0.35		0.35	
$\Delta R_{ON}$	On-Resistance Match Between Channels (Notes 2 and 3)	$V_{IS} = 1.3 \text{ V};$ $I_{COM} = 100 \text{ mA}$ $V_{IS} = 1.5 \text{ V};$ $I_{COM} = 100 \text{ mA}$ $V_{IS} = 2.8 \text{ V};$ $I_{COM} = 100 \text{ mA}$	2.5		0.18		0.18		0.18	$\Omega$
			3.0		0.06		0.06		0.06	
			5.0		0.06		0.06		0.06	
$I_{NC(OFF)}$ $I_{NO(OFF)}$	NC or NO Off Leakage Current (Figure 10)	$V_{IN} = V_{IL} \text{ or } V_{IH}$ $V_{NO} \text{ or } V_{NC} = 1.0$ $V_{COM} = 4.5 \text{ V}$	5.5	-1	1	-10	10	-150	150	nA
$I_{COM(ON)}$	COM ON Leakage Current (Figure 10)	$V_{IN} = V_{IL} \text{ or } V_{IH}$ $V_{NO} 1.0 \text{ V or } 4.5 \text{ V with}$ $V_{NC} \text{ floating or}$ $V_{NC} 1.0 \text{ V or } 4.5 \text{ V with}$ $V_{NO} \text{ floating}$ $V_{COM} = 1.0 \text{ V or } 4.5 \text{ V}$	5.5	-1	1	-10	10	-150	150	nA

2. Guaranteed by design. Resistance measurements do not include test circuit or package resistance.
3.  $\Delta R_{ON} = R_{ON(MAX)} - R_{ON(MIN)}$  between all switches.
4. Flatness is defined as the difference between the maximum and minimum value of on-resistance as measured over the specified analog signal ranges.

# NLAS4685

## AC ELECTRICAL CHARACTERISTICS (Input $t_r = t_f = 3.0$ ns)

Symbol	Parameter	Test Conditions	$V_{CC}$ (V)	$V_{IS}$ (V)	Guaranteed Maximum Limit						Unit	
					-55°C to 25°C			< 85°C		< 125°C		
					Min	Typ*	Max	Min	Max	Min		Max
$t_{ON}$	Turn-On Time	$R_L = 50 \Omega$ , $C_L = 35$ pF (Figures 2 and 3)	2.5	1.3			55		65		70	ns
			3.0	1.5			50		60		60	
			5.0	2.8			30		35		35	
$t_{OFF}$	Turn-Off Time	$R_L = 50 \Omega$ , $C_L = 35$ pF (Figures 2 and 3)	2.5	1.3			55		65		70	ns
			3.0	1.5			50		60		60	
			5.0	2.8			25		30		30	
$t_{BBM}$	Minimum Break-Before-Make Time	$V_{IS} = 3.0$ $R_L = 300 \Omega$ , $C_L = 35$ pF (Figure 1)	3.0	1.5	2	15						ns

	Parameter	Typical @ 25, $V_{CC} = 5.0$ V	$V_{CC} = 3.0$ V	Unit
		$C_{NC\ Off}$	NC Off Capacitance, $f = 1$ MHz	
$C_{NO\ Off}$	NO Off Capacitance, $f = 1$ MHz		102	
$C_{NC\ On}$	NC On Capacitance, $f = 1$ MHz		547	
$C_{NO\ On}$	NO On Capacitance, $f = 1$ MHz		431	

\*Typical Characteristics are at 25°C.

## ADDITIONAL APPLICATION CHARACTERISTICS (Voltages Referenced to GND Unless Noted) (Note 6)

Symbol	Parameter	Condition	$V_{CC}$ V	Typical	Unit
				25°C	
BW	Maximum On-Channel -3dB Bandwidth or Minimum Frequency Response	$V_{IN} = 0$ dBm $V_{IN}$ centered between $V_{CC}$ and GND (Figure 4)	NC/NO 3.0	11.5	MHz
$V_{ONL}$	Maximum Feed-through On Loss	$V_{IN} = 0$ dBm @ 100 kHz to 50 MHz $V_{IN}$ centered between $V_{CC}$ and GND (Figure 4)	3.0	-0.05	dB
$V_{ISO}$	Off-Channel Isolation	$f = 100$ kHz; $V_{IS} = 1$ V RMS; $C_L = 5$ nF $V_{IN}$ centered between $V_{CC}$ and GND (Figure 4)	3.0	-65	dB
Q	Charge Injection Select Input to Common I/O	$V_{IN} = V_{CC}$ to GND, $R_{IS} = 0 \Omega$ , $C_L = 1$ nF $Q = C_L - \Delta V_{OUT}$ (Figure 5)	3.0 5.0	15 20	pC
THD	Total Harmonic Distortion THD + Noise	$F_{IS} = 20$ Hz to 20 kHz, $R_L = R_{gen} = 600 \Omega$ , $C_L = 50$ pF $V_{IS} = 1$ V RMS	3.0	0.14	%
VCT	Channel-to-Channel Crosstalk	$f = 100$ kHz; $V_{IS} = 1$ V RMS, $C_L = 5$ pF, $R_L = 50 \Omega$ $V_{IN}$ centered between $V_{CC}$ and GND (Figure 4)	3.0	-81	dB

5. Off-Channel Isolation =  $20 \log_{10}(V_{com}/V_{no})$ ,  $V_{com}$  = output,  $V_{no}$  = input to off switch.

6. -40°C specifications are guaranteed by design.

# NLAS4685

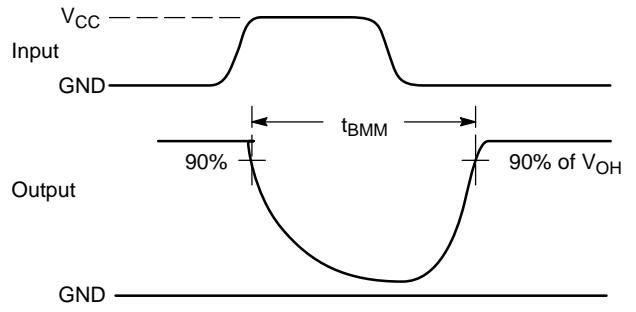
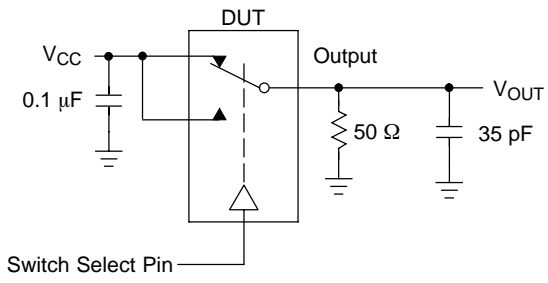

Figure 1.  $t_{BMM}$  (Time Break-Before-Make)

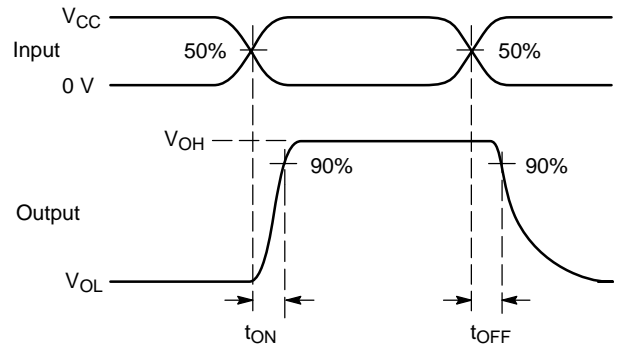
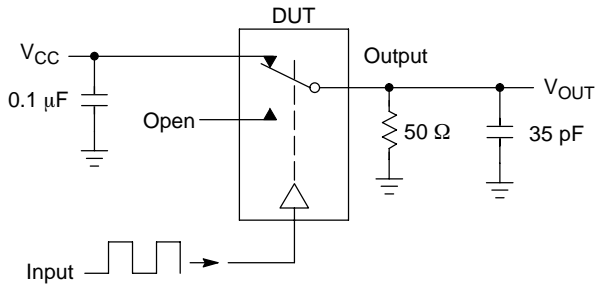

Figure 2.  $t_{ON}/t_{OFF}$

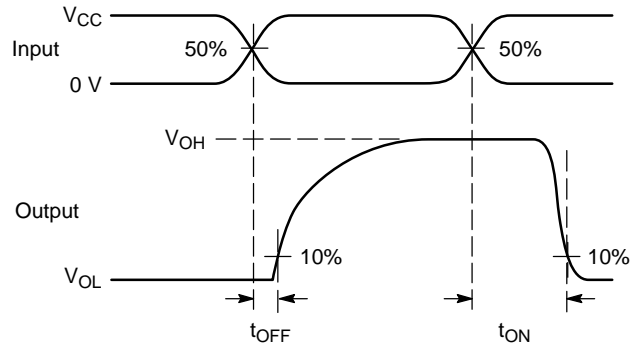
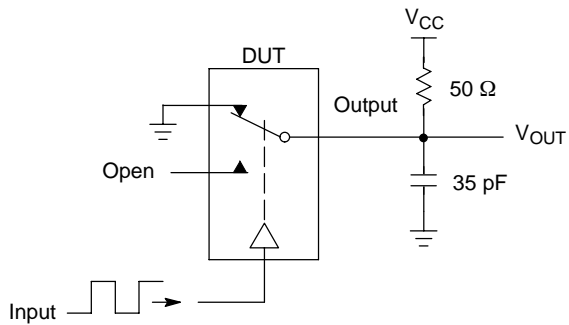
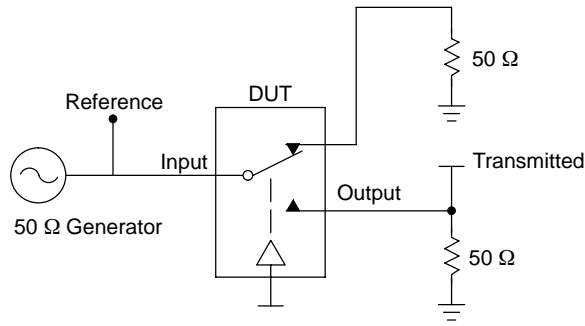

Figure 3.  $t_{ON}/t_{OFF}$

# NLAS4685



Channel switch control/s test socket is normalized. Off isolation is measured across an off channel. On loss is the bandwidth of an On switch.  $V_{ISO}$ , Bandwidth and  $V_{ONL}$  are independent of the input signal direction.

$$V_{ISO} = \text{Off Channel Isolation} = 20 \text{ Log} \left( \frac{V_{OUT}}{V_{IN}} \right) \text{ for } V_{IN} \text{ at } 100 \text{ kHz}$$

$$V_{ONL} = \text{On Channel Loss} = 20 \text{ Log} \left( \frac{V_{OUT}}{V_{IN}} \right) \text{ for } V_{IN} \text{ at } 100 \text{ kHz to } 50 \text{ MHz}$$

Bandwidth (BW) = the frequency 3 dB below  $V_{ONL}$

$V_{CT}$  = Use  $V_{ISO}$  setup and test to all other switch analog input/outputs terminated with 50 Ω

**Figure 4. Off Channel Isolation/On Channel Loss (BW)/Crosstalk (On Channel to Off Channel)/ $V_{ONL}$**

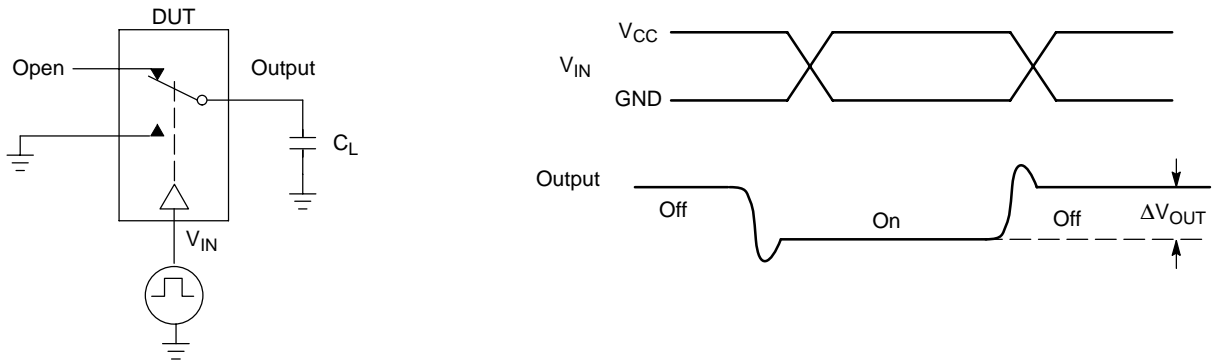

**Figure 5. Charge Injection: (Q)**

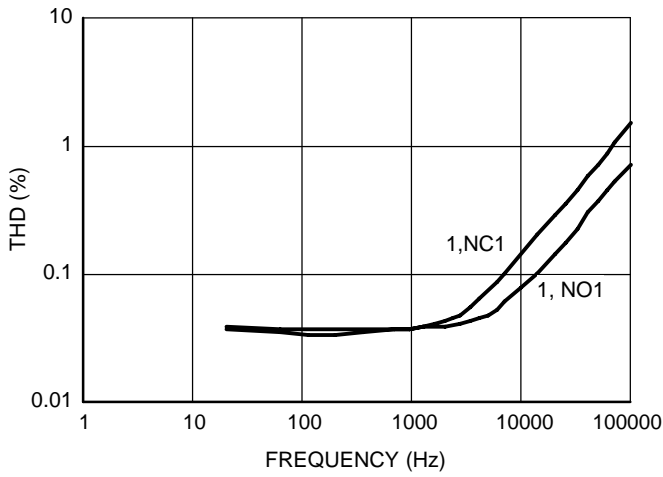

Figure 6. Total Harmonic Distortion Plus Noise versus Frequency

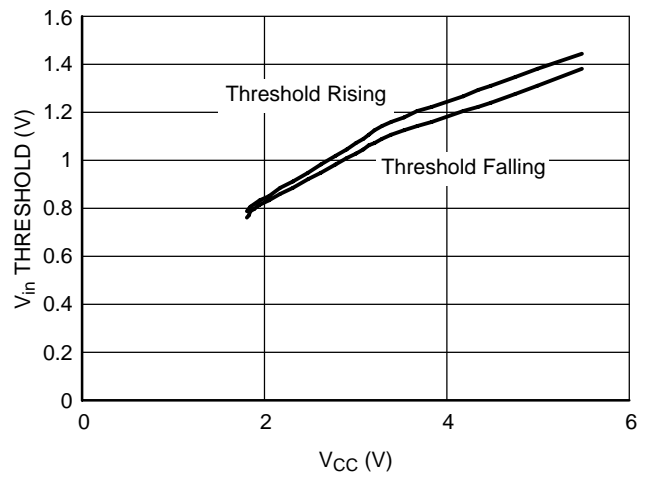

Figure 7. Voltage in Threshold on Logic Pins

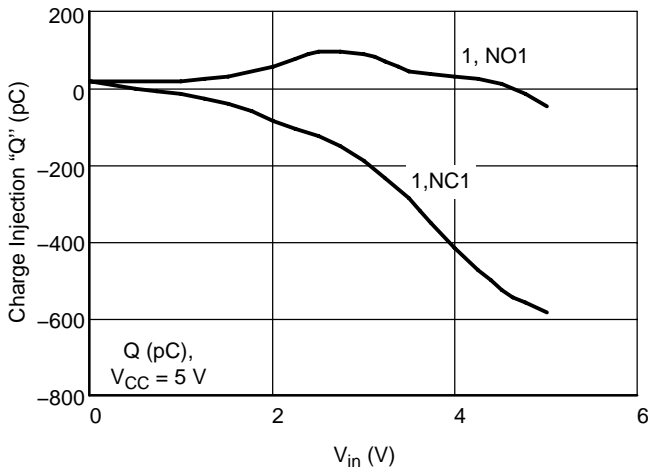

Figure 8. Charge Injection versus  $V_{is}$

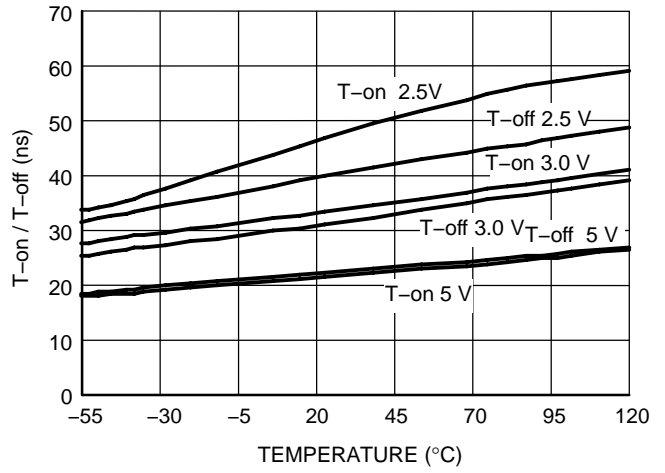

Figure 9. T-on/T-off Time versus Temperature

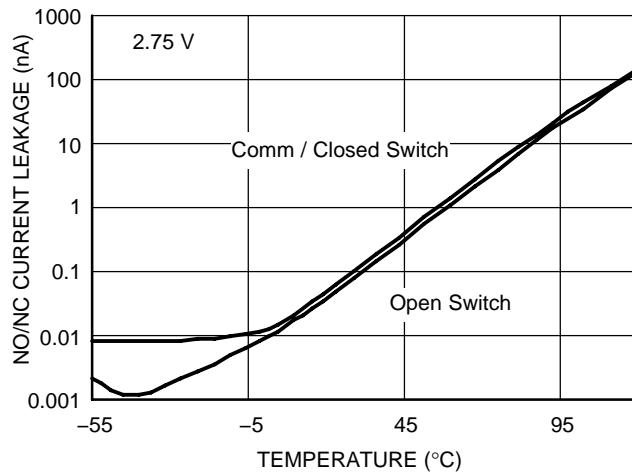
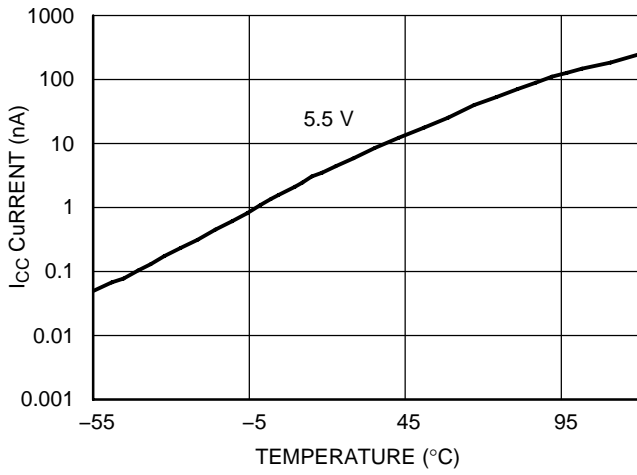
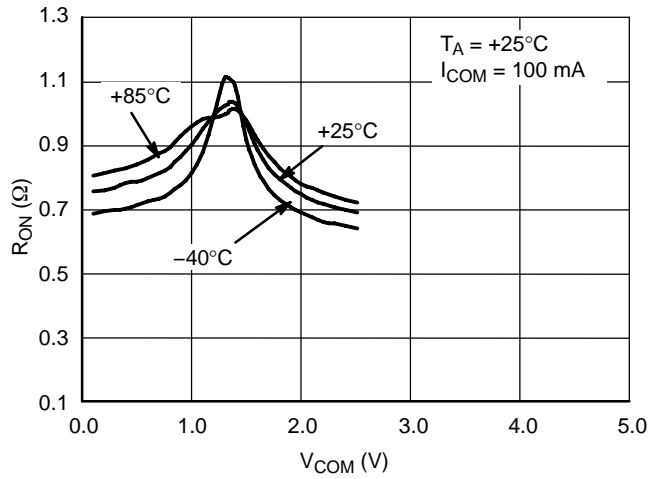

Figure 10. NO/NC Current Leakage Off and On,  $V_{CC} = 5 V$

# NLAS4685



**Figure 11. I<sub>CC</sub> Current Leakage versus Temperature V<sub>CC</sub> = 5.5 V**



**Figure 12. NC/NO On-Resistance versus COM Voltage**

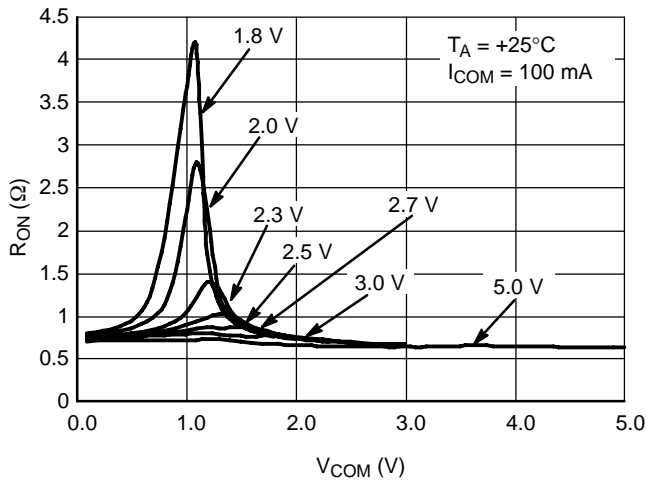

**Figure 13. NC/NO On-Resistance versus COM Voltage**

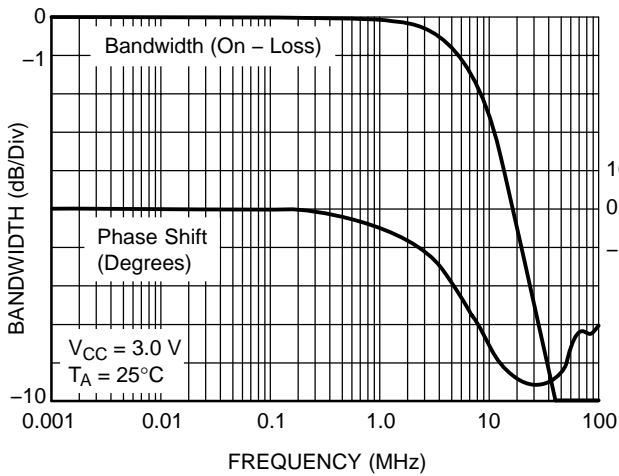

**Figure 14. NC/NO Bandwidth and Phase Shift versus Frequency**

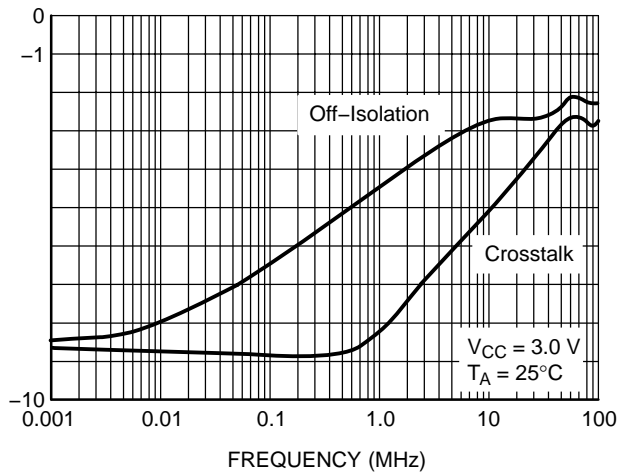

**Figure 15. NC/NO Off Isolation and Crosstalk**

# NLAS4685

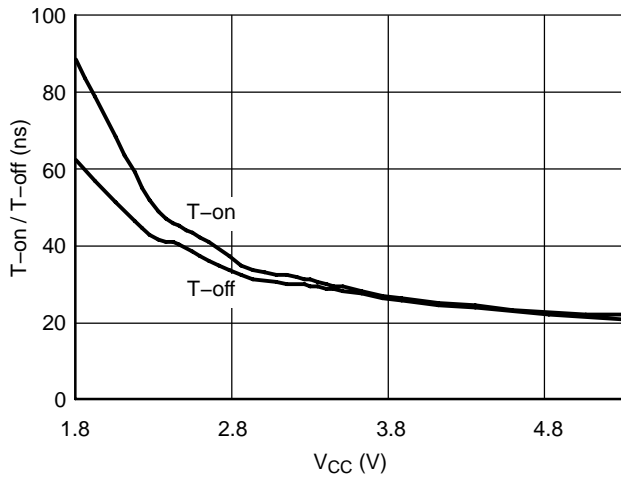

Figure 16. T-on/T-off versus V<sub>CC</sub>

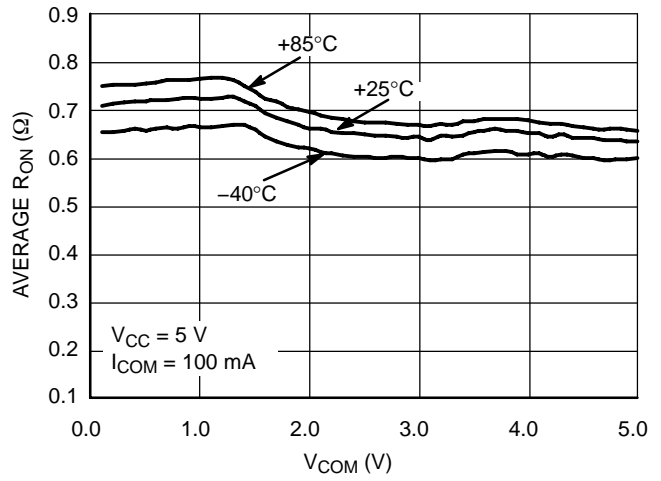

Figure 17. NC/NO On-Resistance versus COM Voltage

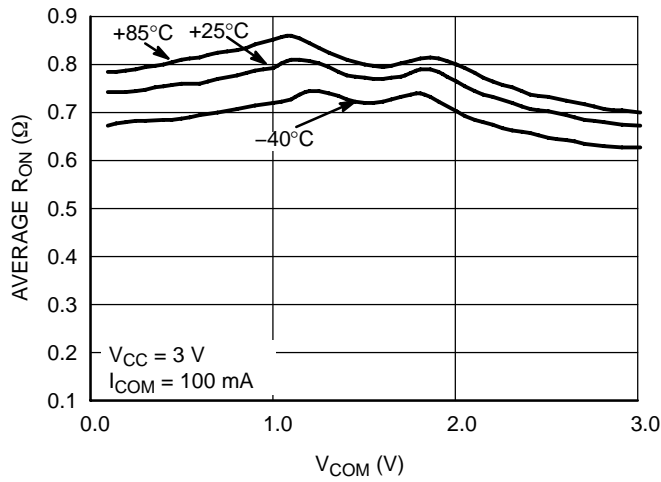
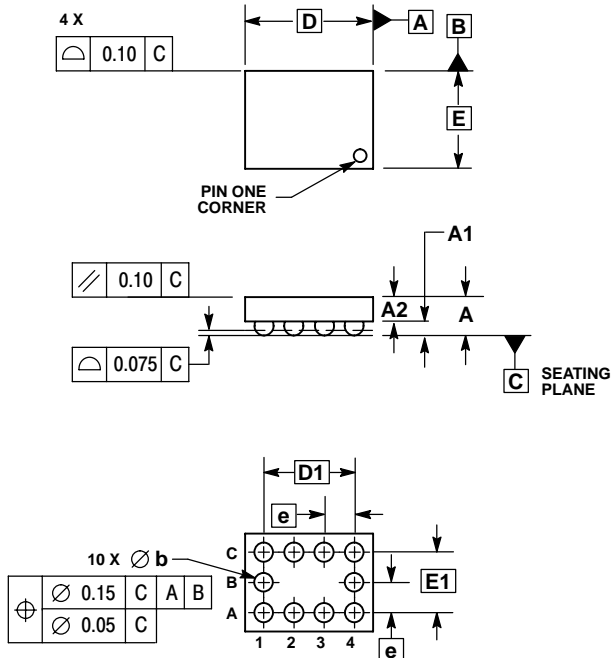

Figure 18. NC/NO On-Resistance versus COM Voltage

# NLAS4685

## PACKAGE DIMENSIONS

Microbump-10  
CASE 489AA-01  
ISSUE O



- NOTES:
1. DIMENSIONING AND TOLERANCING PER ASME Y14.5M, 1994.
  2. CONTROLLING DIMENSION: MILLIMETERS.
  3. COPLANARITY APPLIES TO SPHERICAL CROWNS OF SOLDER BALLS.

DIM	MILLIMETERS	
	MIN	MAX
A	---	0.650
A1	0.210	0.270
A2	0.280	0.380
D	1.965 BSC	
E	1.465 BSC	
b	0.250	0.350
e	0.500 BSC	
D1	1.500 BSC	
E1	1.000 BSC	

ON Semiconductor and are registered trademarks of Semiconductor Components Industries, LLC (SCILLC). SCILLC reserves the right to make changes without further notice to any products herein. SCILLC makes no warranty, representation or guarantee regarding the suitability of its products for any particular purpose, nor does SCILLC assume any liability arising out of the application or use of any product or circuit, and specifically disclaims any and all liability, including without limitation special, consequential or incidental damages. "Typical" parameters which may be provided in SCILLC data sheets and/or specifications can and do vary in different applications and actual performance may vary over time. All operating parameters, including "Typicals" must be validated for each customer application by customer's technical experts. SCILLC does not convey any license under its patent rights nor the rights of others. SCILLC products are not designed, intended, or authorized for use as components in systems intended for surgical implant into the body, or other applications intended to support or sustain life, or for any other application in which the failure of the SCILLC product could create a situation where personal injury or death may occur. Should Buyer purchase or use SCILLC products for any such unintended or unauthorized application, Buyer shall indemnify and hold SCILLC and its officers, employees, subsidiaries, affiliates, and distributors harmless against all claims, costs, damages, and expenses, and reasonable attorney fees arising out of, directly or indirectly, any claim of personal injury or death associated with such unintended or unauthorized use, even if such claim alleges that SCILLC was negligent regarding the design or manufacture of the part. SCILLC is an Equal Opportunity/Affirmative Action Employer. This literature is subject to all applicable copyright laws and is not for resale in any manner.

### PUBLICATION ORDERING INFORMATION

**LITERATURE FULFILLMENT:**  
Literature Distribution Center for ON Semiconductor  
P.O. Box 61312, Phoenix, Arizona 85082-1312 USA  
**Phone:** 480-829-7710 or 800-344-3860 Toll Free USA/Canada  
**Fax:** 480-829-7709 or 800-344-3867 Toll Free USA/Canada  
**Email:** orderlit@onsemi.com

**N. American Technical Support:** 800-282-9855 Toll Free  
USA/Canada

**Japan:** ON Semiconductor, Japan Customer Focus Center  
2-9-1 Kamimeguro, Meguro-ku, Tokyo, Japan 153-0051  
**Phone:** 81-3-5773-3850

**ON Semiconductor Website:** <http://onsemi.com>

**Order Literature:** <http://www.onsemi.com/litorder>

For additional information, please contact your local Sales Representative.

## Looking for pricing, stock, or lifecycle information?

Click below to explore more details on WIN SOURCE:

 [View NLAS4685FCT1G on WIN SOURCE](#)

 [ON Semiconductor](#) Information

## Optimize Your Supply Chain with WIN SOURCE Solutions

-  Global Sourcing Solution
-  Obsolete Management
-  Cost Control Management
-  Shortage Management
-  Alternative Solution
-  Excess Inventory Management