



**THE DATASHEET OF  
NLA54717EPFCT1G**



# NLAS4717EP

## 4.5 $\Omega$ High Bandwidth, Dual SPDT Analog Switch

The NLAS4717EP is an advanced CMOS analog switch fabricated in sub-micron silicon gate CMOS technology. The device is a dual independent Single Pole Double Throw (SPDT) switch featuring low  $R_{DS(on)}$  of 4.5  $\Omega$  at 3.0 V.

The device also features guaranteed Break-Before-Make (BBM) switching, assuring the switches never short the driver.

The NLAS4717EP is available in two small size packages:

- ◆ Microbump: 2.0 x 1.5 mm
- ◆ WQFN-10: 1.4 x 1.8 mm

### Features

- Low  $R_{DS(on)}$ : 4.5  $\Omega$  @ 3.0 V
- Matching Between the Switches  $\pm 0.5 \Omega$
- Wide Voltage Range: 1.8 V to 5.5 V
- High Bandwidth > 90 MHz
- 1.65 V to 5.5 V Operating Range
- Low Threshold Voltages on Pins 4 and 8 (CTRL Pins)
- Ultra-Low Charge Injection  $\leq 6.0$  pC
- Low Standby Current:  $I_{CC} = 1.0$  nA (Max) @  $T_A = 25^\circ\text{C}$
- \*OVT on Pins 4 and 8 (CTRL Logic Pins)
- These are Pb-Free Devices

### Typical Applications

- Cell Phones
- PDAs
- MP3s
- Digital Still Cameras
- USB 2.0 Full Speed (USB1.1) – 12 Mbps Compliant

### Important Information

- ESD Protection:
  - ◆ Human Body Model (HBM) = 2500 V,
  - ◆ Machine Model (MM) = 200 V
- Latchup Max Rating: 200 mA (Per JEDEC EIA/JESD78)
- Pin-to-Pin Compatible with MAX4717

### \*OVT

- Overvoltage Tolerant (OVT) specific pins operate higher than normal supply voltages, with no damage to the devices or to signal integrity.



**ON Semiconductor**<sup>®</sup>

<http://onsemi.com>

### MARKING DIAGRAMS



A1

**Microbump-10  
CASE 489AA**

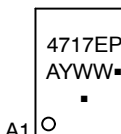

A = Assembly Location  
Y = Year  
W, WW = Work Week  
▪ = Pb-Free Package  
(Note: Microdot may be in either location)



1

**WQFN-10  
CASE 488AQ**



AW = Specific Device Code  
M = Date Code  
▪ = Pb-Free Device  
(Note: Microdot may be in either location)

### FUNCTION TABLE

IN <sub>-</sub>	NO <sub>-</sub>	NC <sub>-</sub>
0	OFF	ON
1	ON	OFF

### ORDERING INFORMATION

Device	Package	Shipping <sup>†</sup>
NLAS4717EPFCT1G	Microbump-10 (Pb-Free)	3000 / Tape & Reel
NLAS4717EPMTR2G	WQFN-10 (Pb-Free)	3000 / Tape & Reel

<sup>†</sup>For information on tape and reel specifications, including part orientation and tape sizes, please refer to our Tape and Reel Packaging Specifications Brochure, BRD8011/D.

# NLAS4717EP

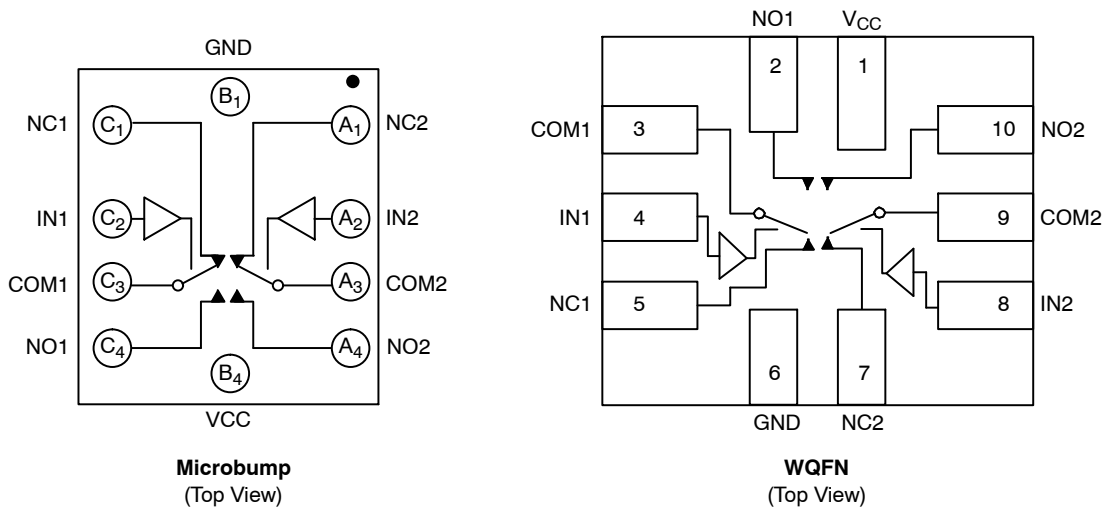

**Figure 1. Device Circuit Diagrams and Pin Configurations**

## MAXIMUM RATINGS

Symbol	Parameter	Value	Unit
V+	DC Supply Voltage	-0.5 to +7.0	V
V <sub>IS</sub>	Analog Input Voltage (V <sub>NO</sub> , V <sub>NC</sub> , or V <sub>COM</sub> ) (Note 1)	-0.5 ≤ V <sub>IS</sub> ≤ V <sub>CC</sub> + 0.5	V
V <sub>IN</sub>	Digital Select Input Voltage	-0.5 ≤ V <sub>I</sub> ≤ +7.0	V
I <sub>IK</sub>	DC Current, Into or Out of Any Pin (Continuous)	±100	mA
I <sub>PK</sub>	Peak Current (10% Duty Cycle)	±200	mA

Stresses exceeding Maximum Ratings may damage the device. Maximum Ratings are stress ratings only. Functional operation above the Recommended Operating Conditions is not implied. Extended exposure to stresses above the Recommended Operating Conditions may affect device reliability.

- Signal voltage on NC, NO, and COM exceeding V<sub>CC</sub> or GND are clamped by the internal diodes. Limit forward diode current to maximum current rating.

## RECOMMENDED OPERATING CONDITIONS

Symbol	Parameter	Min	Max	Unit
V+	DC Supply Voltage	1.8	5.5	V
V <sub>IN</sub>	Digital Select Input Voltage	GND	5.5	V
V <sub>IS</sub>	Analog Input Voltage (NC, NO, COM)	GND	V <sub>CC</sub>	V
T <sub>A</sub>	Operating Temperature Range	-40	+85	°C
t <sub>r</sub> , t <sub>f</sub>	Input Rise or Fall Time, SELECT V <sub>CC</sub> = 3.3 V ± 0.3 V V <sub>CC</sub> = 5.0 V ± 0.5 V	0 0	100 20	ns/V

# NLAS4717EP

## ANALOG SWITCH DC CHARACTERISTICS

Symbol	Parameter	Condition	V <sub>CC</sub> (V)	-40°C to +85°C		Unit
				Min	Max	
V <sub>IH</sub>	Input Logic High Voltage	V <sub>OUT</sub> = 0.1 V I <sub>OUT</sub> ≤ 20 μA	1.65 to 2.2 2.7 to 3.6 4.5 to 5.5	V <sub>CC</sub> × 0.55 V <sub>CC</sub> × 0.5 2.0	- - -	V
V <sub>IL</sub>	Input Logic Low Voltage	V <sub>OUT</sub> = -V <sub>CC</sub> - 0.1 V I <sub>OUT</sub> ≤ 20 μA	1.65 to 2.2 2.7 to 3.6 4.5 to 5.5	- - -	V <sub>CC</sub> × 0.2 V <sub>CC</sub> × 0.2 0.8	V
I <sub>IN</sub>	Input Leakage Current	V <sub>IN</sub> = V <sub>CC</sub> or GND	5.5	-100	+100	nA
V <sub>CC</sub>	Power Supply Range	All	-	1.65	5.5	V
I <sub>CC</sub>	Supply Current	V <sub>IN</sub> = V <sub>CC</sub> or GND I <sub>OUT</sub> = 0 μA	1.8 3.3 5.5	- - -	1.0 1.0 1.0	μA

## ANALOG SWITCH CHARACTERISTICS – Digital Section (Voltages Referenced to GND)

Symbol	Parameter	Condition	V <sub>CC</sub> (V)	-40°C to +85°C			Unit
				Min	Typ	Max	
R <sub>ON</sub>	ON Resistance (Note 2)	I <sub>COM</sub> = 10 mA V <sub>IS</sub> = 0 to V <sub>CC</sub>	3.0	-	3.2	4.5	Ω
			5.0	-	2.1	3.5	
ΔR <sub>ON</sub>	ON Resistance Match Between Channels (Note 2 and 3)	I <sub>COM</sub> = 10 mA V <sub>IS</sub> = 0 to V <sub>CC</sub>	3.0	-	0.1	0.4	Ω
			5.0	-	0.1	0.4	
R <sub>FLAT[ON]</sub>	ON Resistance Flatness (Note 4)	I <sub>COM</sub> = 10 mA V <sub>IS</sub> = 0 to V <sub>CC</sub>	3.0	-	1.12	1.5	Ω
			5.0	-	0.55	1.36	
I <sub>NO_[OFF]</sub> I <sub>NC_[OFF]</sub>	NO_, NC_ Off-Leakage Current (Note 5)	V <sub>COM</sub> = 0.3 V or 3.3 V V <sub>NO</sub> or V <sub>NC</sub> = 0.3 V or 3.3 V	3.6	-1.0	0.01	+1.0	nA
			5.5	-1.0	0.01	+1.0	
I <sub>COM_[ON]</sub>	COM_ On-Leakage Current (Note 5)	V <sub>COM</sub> = 0.3 V or 3.3 V V <sub>NO</sub> or V <sub>NC</sub> = 0.3 V or 3.3 V	3.6	-2.0	0.01	+2.0	nA
			5.5	-2.0	0.01	+2.0	

# NLAS4717EP

## ANALOG SWITCH AC CHARACTERISTICS

Symbol	Parameter	Condition	V <sub>CC</sub> (V)	-40°C to +85°C			Unit
				Min	Typ	Max	
t <sub>ON</sub>	Turn-On Time	V <sub>NC_</sub> , V <sub>NO_</sub> = V <sub>IH</sub> or V <sub>IL</sub> R <sub>L</sub> = 300 Ω, C <sub>L</sub> = 35 pF V <sub>IN[x]</sub> = V <sub>IH</sub> or V <sub>IL</sub>	1.8 to 5.5	-	-	30	nS
t <sub>OFF</sub>	Turn-Off Time	V <sub>NC_</sub> , V <sub>NO_</sub> = V <sub>IH</sub> or V <sub>IL</sub> R <sub>L</sub> = 300 Ω, C <sub>L</sub> = 35 pF V <sub>IN[x]</sub> = V <sub>IH</sub> or V <sub>IL</sub>	1.8 to 5.5	-	-	40	nS
t <sub>BBM</sub>	Break-Before-Make Time Delay (Note 5)	V <sub>NC_</sub> , V <sub>NO_</sub> = 1.5 V R <sub>L</sub> = 300 Ω, C <sub>L</sub> = 35 pF	-	-	8.0	-	nS
t <sub>SKEW</sub>	Skew (Note 5)	R <sub>S</sub> = 39 Ω, C <sub>L</sub> = 50 pF	-	-	0.15	2.0	nS

- R<sub>ON</sub> characterized for V<sub>CC</sub> range (1.65 V to 5.5 V).
- ΔR<sub>ON</sub> = R<sub>ON</sub>(MAX) - R<sub>ON</sub>(MIN).
- R<sub>FLAT[ON]</sub> = R<sub>ON</sub>(MAX) - R<sub>ON</sub>(MIN), measured over V<sub>CC</sub> range.
- Guaranteed by design.

## ANALOG SWITCH APPLICATION CHARACTERISTICS

Symbol	Parameter	Condition	V <sub>CC</sub> (V)	-40°C to +85°C			Unit
				Min	Typ	Max	
Q	Charge Injection	V <sub>IN</sub> = V <sub>CC</sub> to GND R <sub>In</sub> = 0 Ω, C <sub>L</sub> = 1.0 nF Q = C <sub>L</sub> - ΔV <sub>OUT</sub>	3.0 5.0		6.0 9.0		pC
VISO	Off-Isolation	f = 10 MHz V <sub>NO_</sub> , V <sub>NC_</sub> = 1.0 Vp-p R <sub>L</sub> = 50 Ω, C <sub>L</sub> = 5.0 pF	1.65 to 5.5		-50		dB
		f = 1.0 MHz V <sub>NO_</sub> , V <sub>NC_</sub> = 1.0 Vp-p R <sub>L</sub> = 50 Ω, C <sub>L</sub> = 5.0 pF			-75		
VCT	Cross-Talk	f = 10 MHz V <sub>NO_</sub> , V <sub>NC_</sub> = 1.0 Vp-p R <sub>L</sub> = 50 Ω, C <sub>L</sub> = 5.0 pF	1.65 to 5.5		-80		dB
		f = 1.0 MHz V <sub>NO_</sub> , V <sub>NC_</sub> = 1.0 Vp-p R <sub>L</sub> = 50 Ω, C <sub>L</sub> = 5.0 pF			-110		
BW	On-Channel -3.0 db Bandwidth	Signal = 0 dB R <sub>L</sub> = 50 Ω, C <sub>L</sub> = 5.0 pF	1.8 to 5.0		90		MHz
THD	Total Harmonic Distortion	V <sub>COM</sub> = 2.0 Vp-p, R <sub>L</sub> = 600 Ω, T <sub>A</sub> = 25°C	-		0.02		%
C <sub>NO_[OFF]</sub> C <sub>NC_[OFF]</sub>	NO_, NC_ OFF-Capacitance	F = 1.0 MHz	-		15		pF
C <sub>NO_[ON]</sub> C <sub>NC_[ON]</sub>	NO_, NC_ ON-Capacitance	F = 1.0 MHz	-		38		pF

# NLAS4717EP

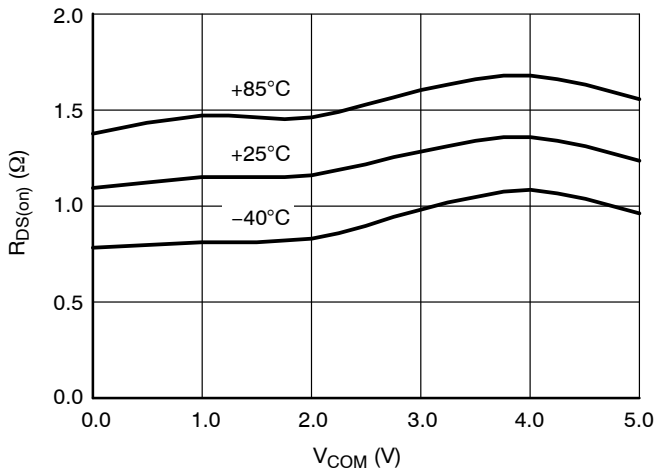

Figure 2. R<sub>DS(on)</sub> @ V<sub>CC</sub> = 5.0 V

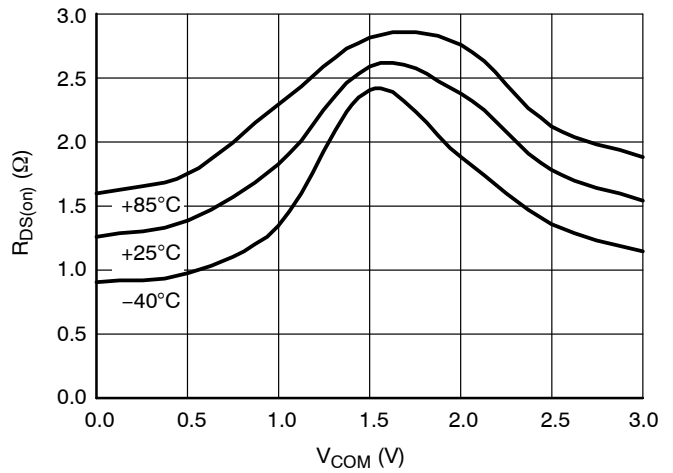

Figure 3. R<sub>DS(on)</sub> @ V<sub>CC</sub> = 3.0 V

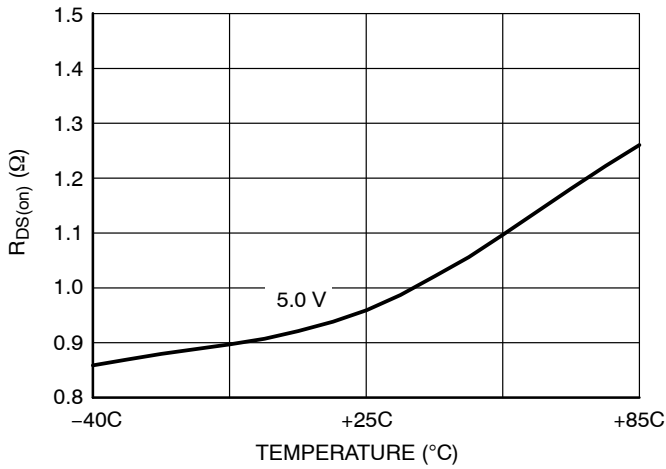

Figure 4. Delta R<sub>DS(on)</sub> @ V<sub>CC</sub> = 5.0 V

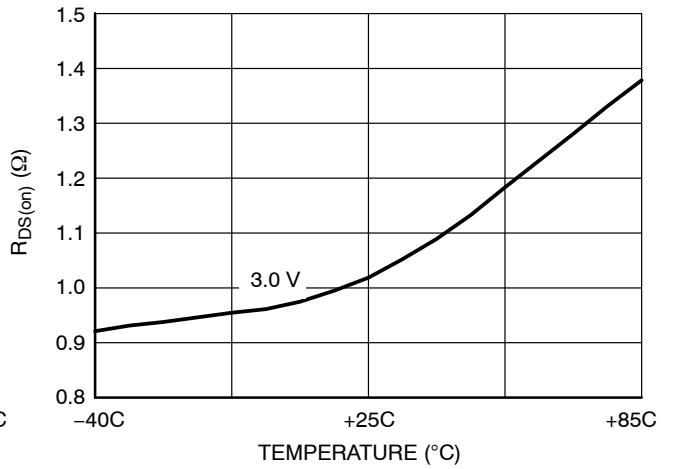

Figure 5. Delta R<sub>DS(on)</sub> @ V<sub>CC</sub> = 3.0 V

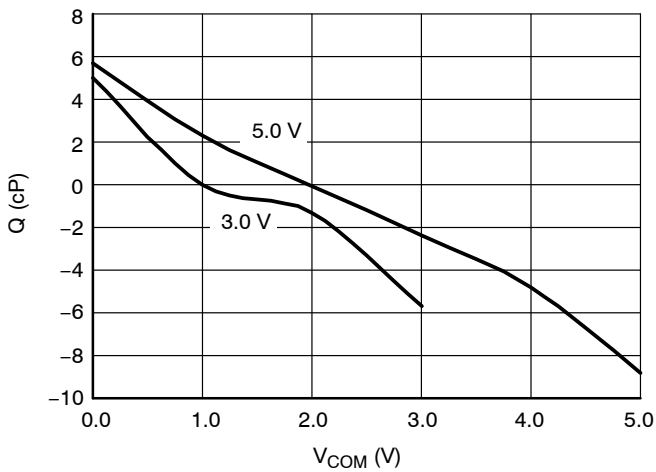

Figure 6. Charge Injection

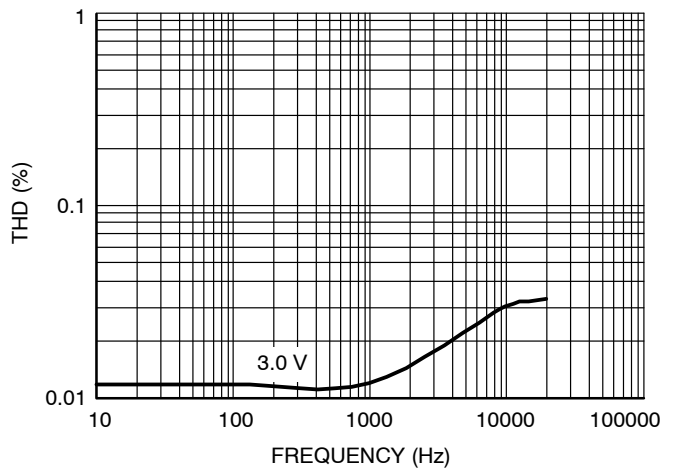

Figure 7. Total Harmonic Distortion

NLAS4717EP

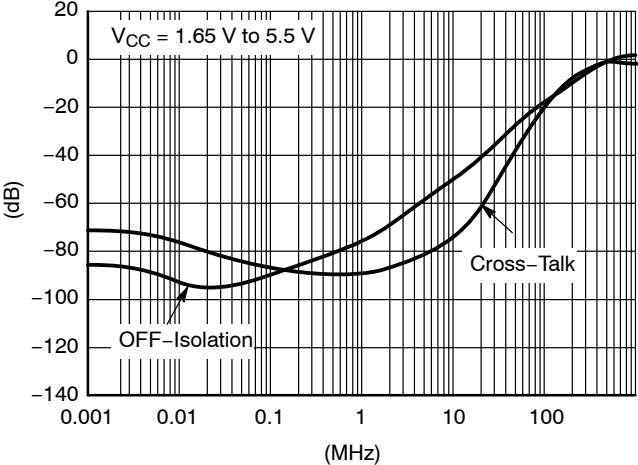

Figure 8. Frequency Response

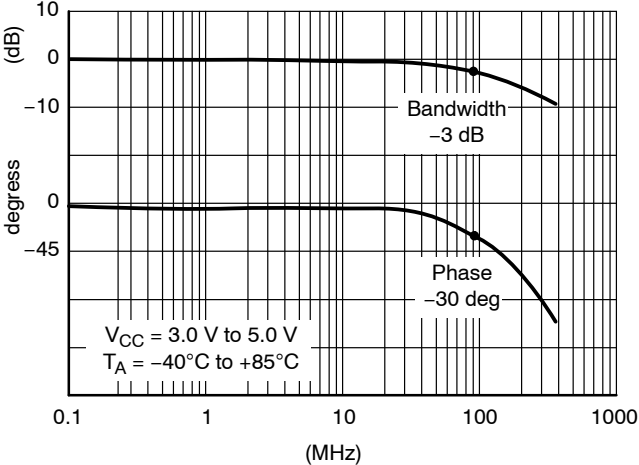

Figure 9. Bandwidth and Phase

# NLAS4717EP

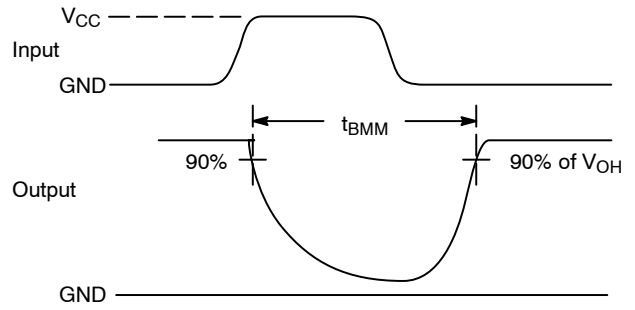
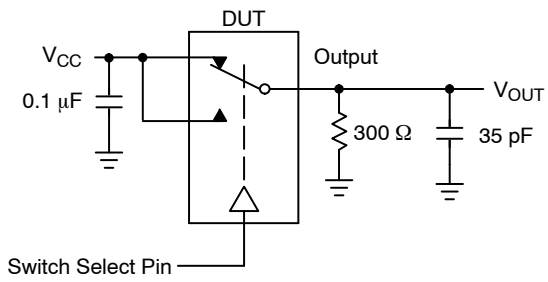

Figure 10.  $t_{BMM}$  (Time Break-Before-Make)

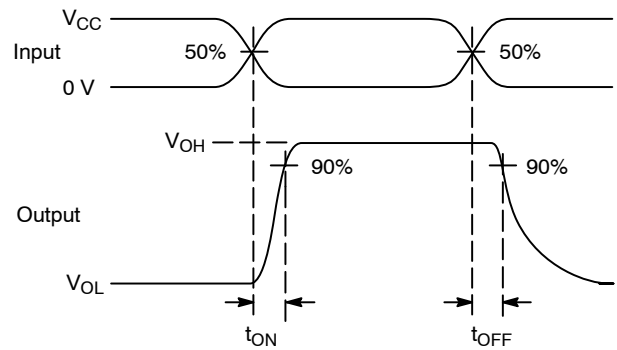
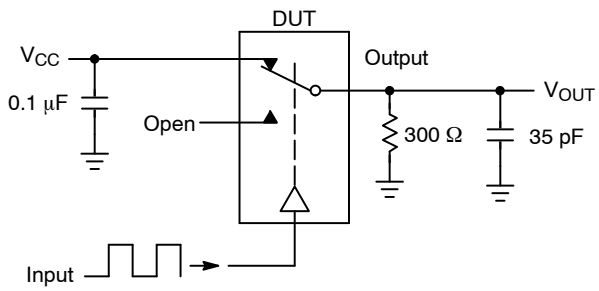

Figure 11.  $t_{ON}/t_{OFF}$

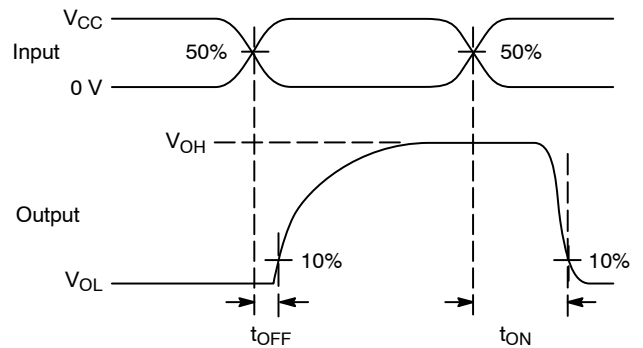
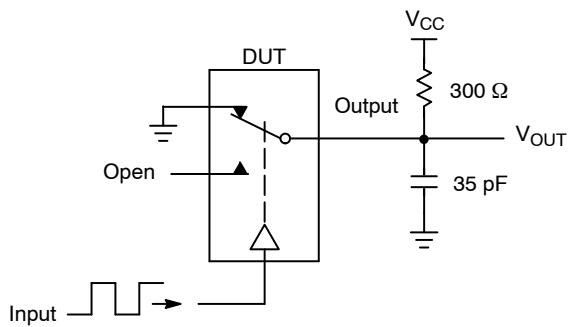
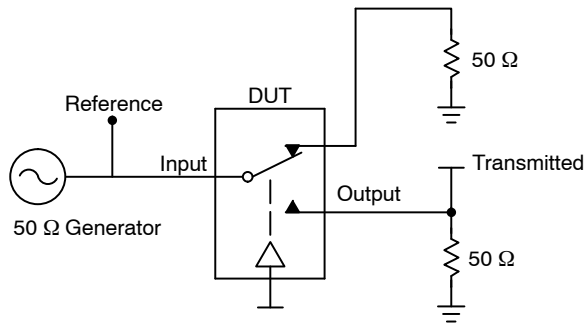

Figure 12.  $t_{ON}/t_{OFF}$

# NLAS4717EP



Channel switch control/s test socket is normalized. Off isolation is measured across an off channel. On loss is the bandwidth of an On switch.  $V_{ISO}$ , Bandwidth and  $V_{ONL}$  are independent of the input signal direction.

$$V_{ISO} = \text{Off Channel Isolation} = 20 \text{ Log} \left( \frac{V_{OUT}}{V_{IN}} \right) \text{ for } V_{IN} \text{ at } 100 \text{ kHz}$$

$$V_{ONL} = \text{On Channel Loss} = 20 \text{ Log} \left( \frac{V_{OUT}}{V_{IN}} \right) \text{ for } V_{IN} \text{ at } 100 \text{ kHz to } 50 \text{ MHz}$$

Bandwidth (BW) = the frequency 3.0 dB below  $V_{ONL}$

$V_{CT}$  = Use  $V_{ISO}$  setup and test to all other switch analog input/outputs terminated with 50  $\Omega$

**Figure 13. Off Channel Isolation/On Channel Loss (BW)/Crosstalk (On Channel to Off Channel)/ $V_{ONL}$**

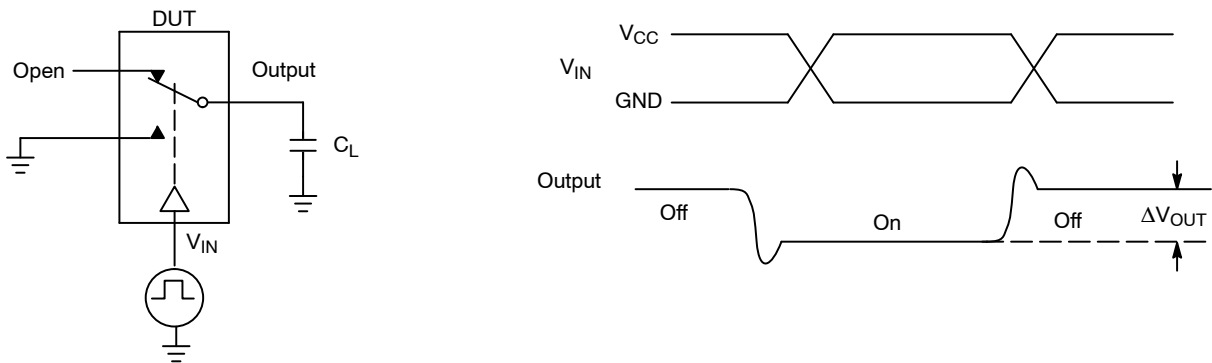
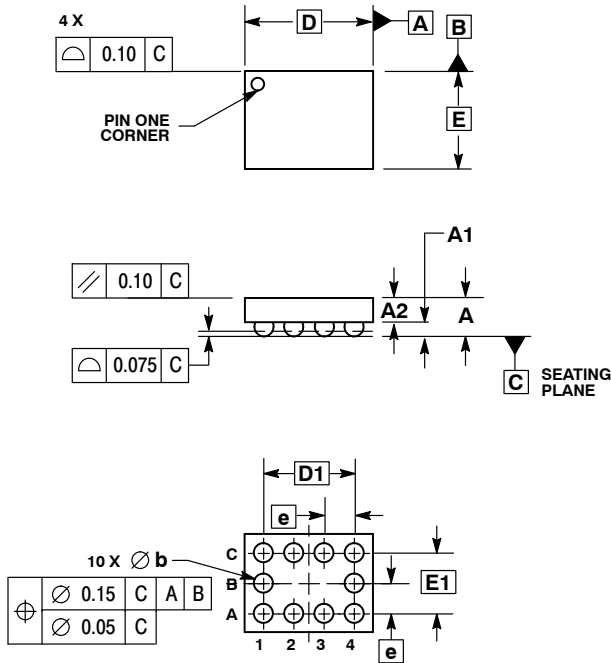

**Figure 14. Charge Injection: (Q)**

# NLAS4717EP

## PACKAGE DIMENSIONS

Microbump-10  
CASE 489AA-01  
ISSUE A



NOTES:

1. DIMENSIONING AND TOLERANCING PER ASME Y14.5M, 1994.
2. CONTROLLING DIMENSION: MILLIMETERS.
3. COPLANARITY APPLIES TO SPHERICAL CROWNS OF SOLDER BALLS.

MILLIMETERS		
DIM	MIN	MAX
A	---	0.650
A1	0.210	0.270
A2	0.280	0.380
D	1.965 BSC	
E	1.465 BSC	
b	0.250	0.350
e	0.500 BSC	
D1	1.500 BSC	
E1	1.000 BSC	

# NLAS4717EP

## PACKAGE DIMENSIONS

WQFN10, 1.4x1.8, 0.4P  
CASE 488AQ-01  
ISSUE C

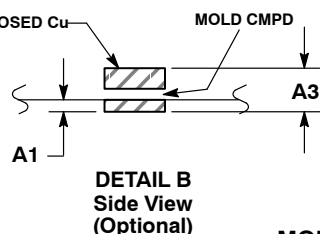
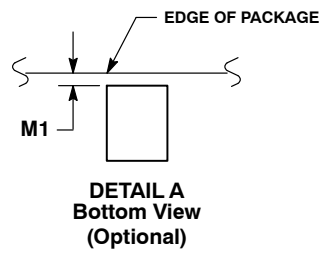
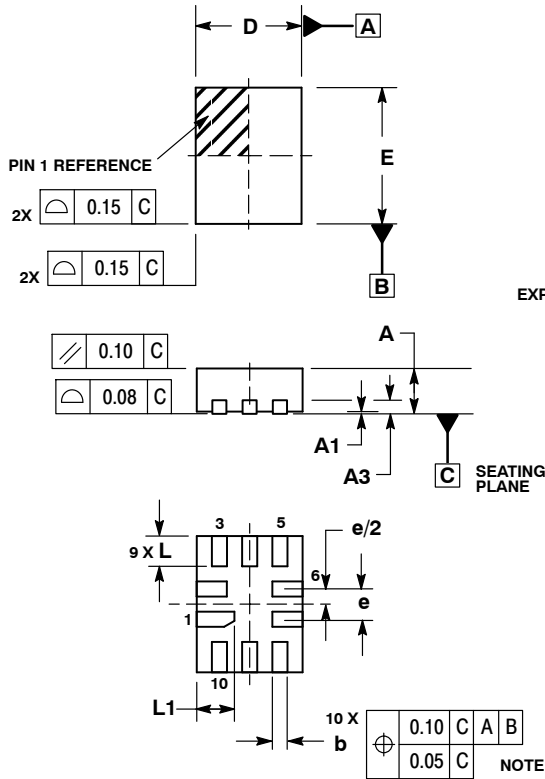

- NOTES:
1. DIMENSIONING AND TOLERANCING PER ASME Y14.5M, 1994.
  2. CONTROLLING DIMENSION: MILLIMETERS
  3. DIMENSION b APPLIES TO PLATED TERMINAL AND IS MEASURED BETWEEN 0.25 AND 0.30 MM FROM TERMINAL.
  4. COPLANARITY APPLIES TO THE EXPOSED PAD AS WELL AS THE TERMINALS.
  5. EXPOSED PADS CONNECTED TO DIE FLAG. USED AS TEST CONTACTS.

MILLIMETERS		
DIM	MIN	MAX
A	0.70	0.80
A1	0.00	0.050
A3	0.20	REF
b	0.15	0.25
D	1.40	BSC
E	1.80	BSC
e	0.40	BSC
L	0.30	0.50
L1	0.40	0.60
M1	0.00	0.05

### MOUNTING FOOTPRINT\*

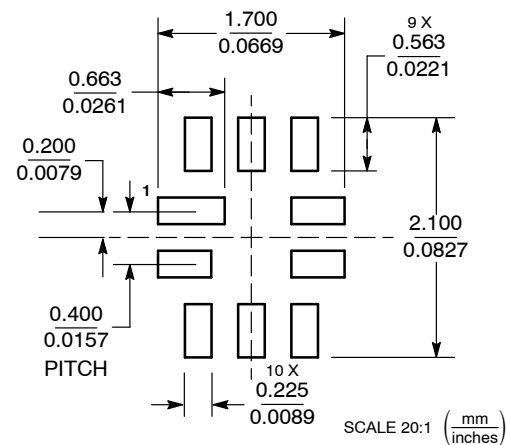

\*For additional information on our Pb-Free strategy and soldering details, please download the ON Semiconductor Soldering and Mounting Techniques Reference Manual, SOLDERRM/D.

ON Semiconductor and are registered trademarks of Semiconductor Components Industries, LLC (SCILLC). SCILLC reserves the right to make changes without further notice to any products herein. SCILLC makes no warranty, representation or guarantee regarding the suitability of its products for any particular purpose, nor does SCILLC assume any liability arising out of the application or use of any product or circuit, and specifically disclaims any and all liability, including without limitation special, consequential or incidental damages. "Typical" parameters which may be provided in SCILLC data sheets and/or specifications can and do vary in different applications and actual performance may vary over time. All operating parameters, including "Typicals" must be validated for each customer application by customer's technical experts. SCILLC does not convey any license under its patent rights nor the rights of others. SCILLC products are not designed, intended, or authorized for use as components in systems intended for surgical implant into the body, or other applications intended to support or sustain life, or for any other application in which the failure of the SCILLC product could create a situation where personal injury or death may occur. Should Buyer purchase or use SCILLC products for any such unintended or unauthorized application, Buyer shall indemnify and hold SCILLC and its officers, employees, subsidiaries, affiliates, and distributors harmless against all claims, costs, damages, and expenses, and reasonable attorney fees arising out of, directly or indirectly, any claim of personal injury or death associated with such unintended or unauthorized use, even if such claim alleges that SCILLC was negligent regarding the design or manufacture of the part. SCILLC is an Equal Opportunity/Affirmative Action Employer. This literature is subject to all applicable copyright laws and is not for resale in any manner.

### PUBLICATION ORDERING INFORMATION

**LITERATURE FULFILLMENT:**  
Literature Distribution Center for ON Semiconductor  
P.O. Box 5163, Denver, Colorado 80217 USA  
**Phone:** 303-675-2175 or 800-344-3860 Toll Free USA/Canada  
**Fax:** 303-675-2176 or 800-344-3867 Toll Free USA/Canada  
**Email:** orderlit@onsemi.com

**N. American Technical Support:** 800-282-9855 Toll Free USA/Canada  
**Europe, Middle East and Africa Technical Support:**  
Phone: 421 33 790 2910  
**Japan Customer Focus Center**  
Phone: 81-3-5817-1050

**ON Semiconductor Website:** [www.onsemi.com](http://www.onsemi.com)  
**Order Literature:** <http://www.onsemi.com/orderlit>  
For additional information, please contact your local Sales Representative

## Looking for pricing, stock, or lifecycle information?

Click below to explore more details on WIN SOURCE:

- ⊖ [View NLAS4717EPFCT1G on WIN SOURCE](#)
- ⊖ [ON Semiconductor Information](#)

## Optimize Your Supply Chain with WIN SOURCE Solutions

- ✓ Global Sourcing Solution
- ✓ Obsolete Management
- ✓ Cost Control Management
- ✓ Shortage Management
- ✓ Alternative Solution
- ✓ Excess Inventory Management