



**THE DATASHEET OF
NLSF595MNR2G**



NLSF595

Serial (SPI) Tri-Color LED Driver

The NLSF595 is advanced CMOS shift register with open drain outputs fabricated with 0.6 μm silicon gate CMOS technology. This device is used in conjunction with a microcontroller, with only one dedicated line. All pins have Overvoltage Protection that allows voltages above V_{CC} up to 7.0 V to be present on the pins without damage or disruption of operation of the part, regardless of the operating voltage. This device may be used between 2.0 and 5.5 volts, the output driver level may be independent of supply voltage: 0–7.0 volts.

Features

- Parallel Outputs are Open Drain Capable of Sinking > 12 mA
 - ◆ Output Withstands up to +7.0 Regardless of V_{CC}
- Standard Serial (SPI) Interface, Data, Clock, Enable (Low)
- All Inputs CMOS Level Compatible
- Frees up I/O around a Microcontroller
- Only One Pin Dedicated to this Device (Latch Enable)
- Output Enable may be Permanently Pulled Low
- High Speed Clocking, F_{max} > 25 MHz (Shift Clock)
- Eight Bits Parallel Output
- Double Buffered Outputs, so Register may Fill without Affecting Output
- STD CMOS Serial Output, may be used to Cascade more than One Device
- Each Part Controls Two Tri-Color LEDs
- Two Devices can Control 5 Tri-Color LEDs
- Low Leakage: $I_{CC} = 2.0 \mu\text{A}$ (Max) at $T_A = 25^\circ\text{C}$
- Latchup Performance Exceeds 100 mA
- QFN-16/TSSOP-16 Packages
- ESD Performance:
 - ◆ Human Body Model; > 2000 V
 - ◆ Machine Model; > 200 V
- Functionally Similar to the Popular 74VHC595
- These Devices are Pb-Free and are RoHS Compliant



ON Semiconductor®

<http://onsemi.com>

MARKING DIAGRAMS



1
QFN-16
MN SUFFIX
CASE 485G

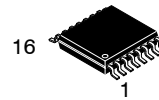
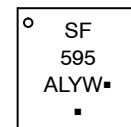

16
1
TSSOP-16
DT SUFFIX
CASE 948F

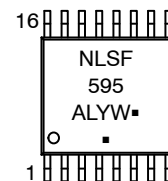

A = Assembly Location
L = Wafer Lot
Y = Year
W = Work Week
■ = Pb-Free Package

(Note: Microdot may be in either location)

ORDERING INFORMATION

See detailed ordering and shipping information in the package dimensions section on page 12 of this data sheet.

NLSF595

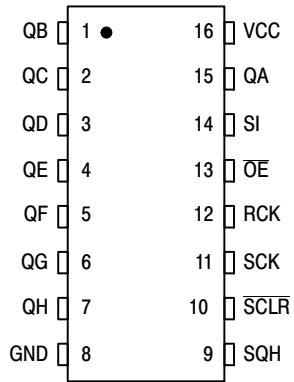

Figure 1. Pin Assignment (TSSOP-16)

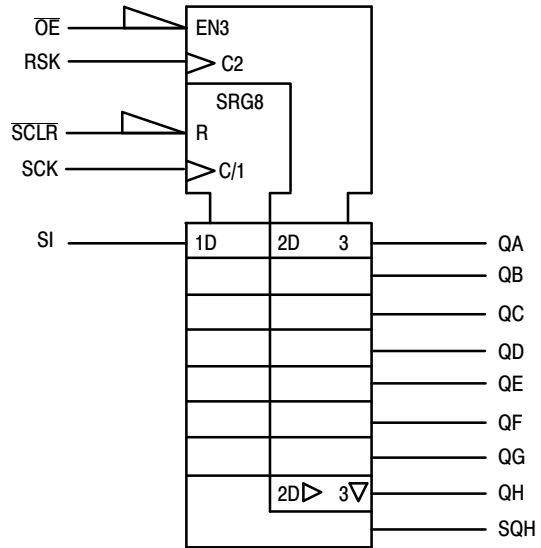

Figure 2. IEC Logic Symbol

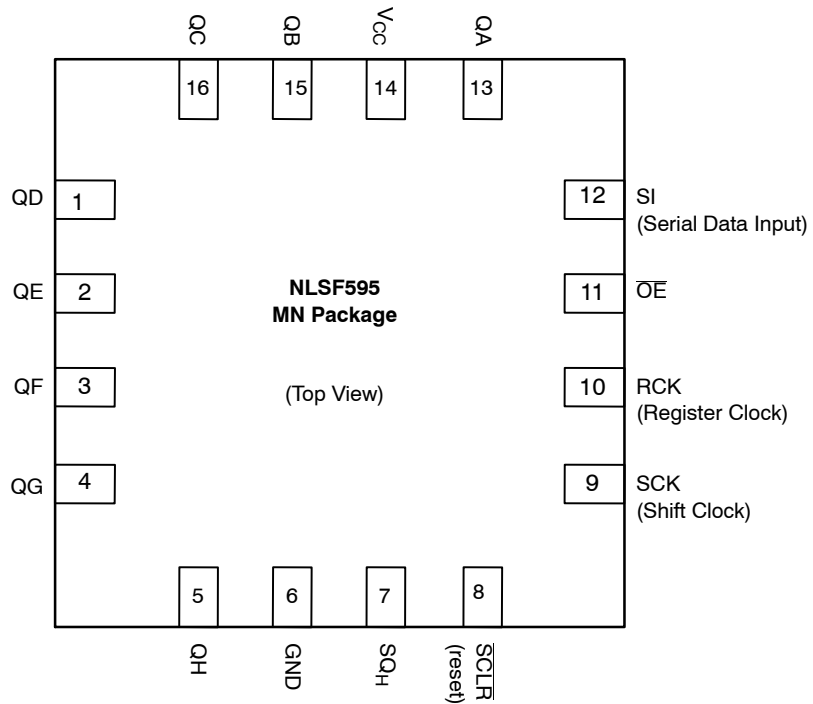

Figure 3. Pin Assignment (QFN-16)

NLSF595

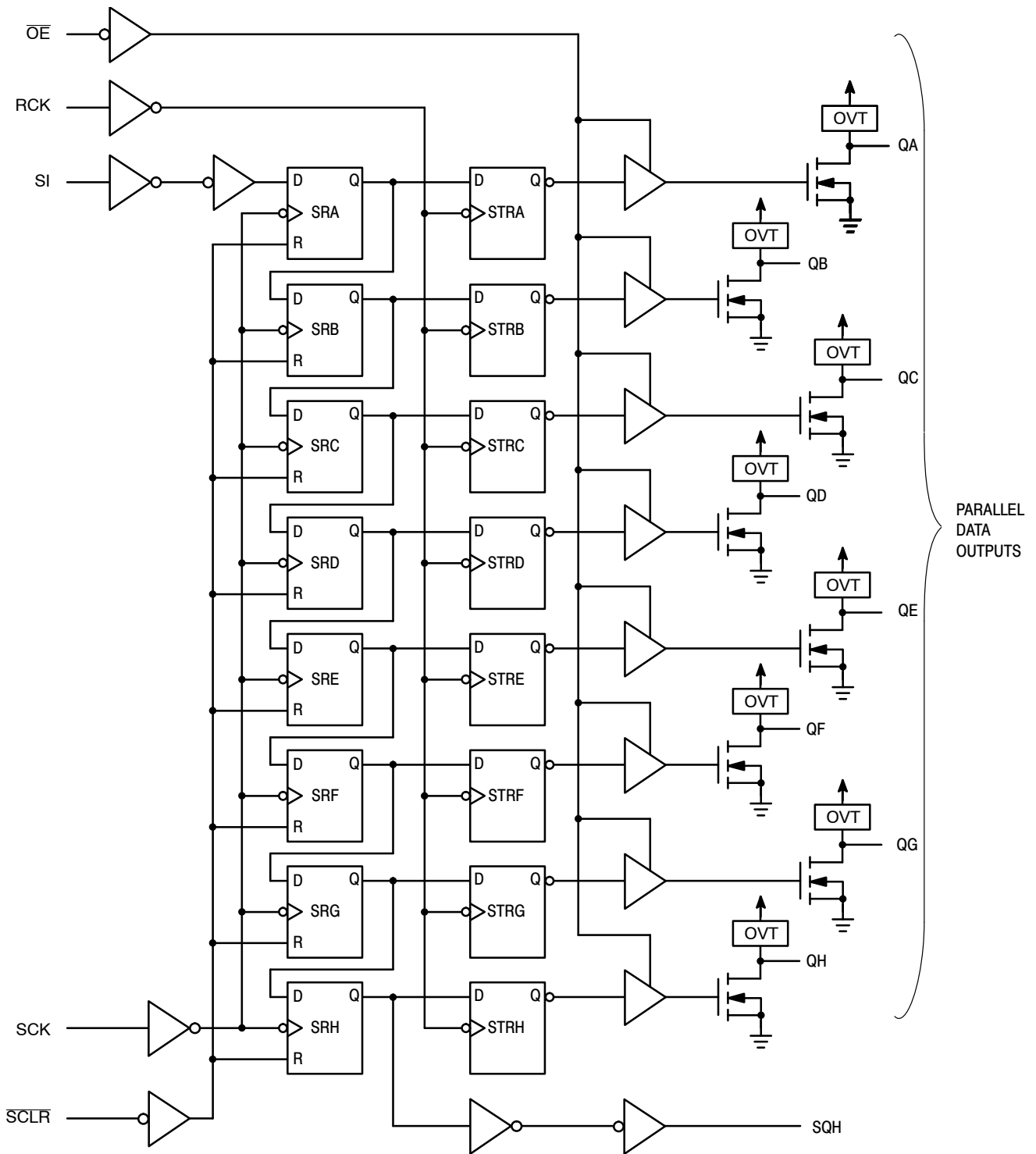

Figure 4. Expanded Logic Diagram

NLSF595

MAXIMUM RATINGS

Symbol	Parameter	Value	Units
V _{CC}	Positive DC Supply Voltage	-0.5 to +7.0	V
V _{IN}	Digital Input Voltage	-0.5 to +7.0	V
V _{OUT}	DC Output Voltage	-0.5 to V _{CC} +7.0	V
I _{IK}	Input Diode Current	-20	mA
I _{OK}	Output Diode Current	±50	mA
I _{OUT}	DC Output Current, per Pin	+50	mA
I _{CC}	DC Supply Current, V _{CC} and GND Pins	±75	mA
P _D	Power Dissipation in Still Air	450	mW
T _{STG}	Storage Temperature Range	-65 to +150	°C
I _{LATCHUP}	Latchup Performance Above V _{CC} and Below GND at 125°C (Note 1)	±300	mA
θ _{JA}	Thermal Resistance, Junction-to-Ambient	128	°C/W

Maximum ratings are those values beyond which device damage can occur. Maximum ratings applied to the device are individual stress limit values (not normal operating conditions) and are not valid simultaneously. If these limits are exceeded, device functional operation is not implied, damage may occur and reliability may be affected.

1. Tested to EIA/JESD78

RECOMMENDED OPERATING CONDITIONS

Symbol	Characteristics	Min	Max	Units
V _{CC}	DC Supply Voltage	2.0	5.5	V
V _{IN}	DC Input Voltage	0	5.5	V
V _{OUT}	DC Output Voltage	0	V _{CC}	V
T _A	Operating Temperature Range, all Package Types	-55	125	°C
t _r , t _f	Input Rise or Fall Time V _{CC} = 3.3 V ± 0.3 V V _{CC} = 5.0 V ± 0.5 V	0	50 15	ns/V

FUNCTION TABLE

Operation	Inputs					Resulting Function			
	Reset (SCLR)	Serial Input (SI)	Shift Clock (SCK)	Reg Clock (RCK)	Output Enable (OE)	Shift Register Contents	Storage Register Contents	Serial Output (SQH)	Parallel Outputs (QA - QH)
Clear shift register	L	X	X	L, H, ↓	L	L	U	L	U
Shift data into shift register	H	D	↑	L, H, ↓	L	D→SR _A ; SR _N →SR _{N+1}	U	SR _G →SR _H	U
Registers remains unchanged	H	X	L, H, ↓	X	L	U	**	U	**
Transfer shift register contents to storage register	H	X	L, H, ↓	↑	L	U	SR _N →STR _N	*	SR _N
Storage register remains unchanged	X	X	X	L, H, ↓	L	*	U	*	U
Enable parallel outputs	X	X	X	X	L	*	**	*	Enabled
Force outputs into high impedance state	X	X	X	X	H	*	**	*	Z

SR = shift register contents

D = data (L, H) logic level

↓ = High-to-Low

* = depends on Reset and Shift Clock inputs

STR = storage register contents

U = remains unchanged

↑ = Low-to-High

** = depends on Register Clock input

NLSF595

DC ELECTRICAL CHARACTERISTICS

Symbol	Parameter	Test Conditions	V _{CC} (V)	T _A = 25°C			T _A ≤ 85°C		T _A ≤ 125°C		Units
				Min	Typ	Max	Min	Max	Min	Max	
V _{IH}	Minimum High-Level Input Voltage		2.0 3.0 4.5 5.5	1.5 2.1 3.15 3.85			1.5 2.1 3.15 3.85		1.5 2.1 3.15 3.85	V	
V _{IL}	Maximum Low-Level Input Voltage		2.0 3.0 4.5 5.5			0.59 0.9 1.35 1.65		0.59 0.9 1.35 1.65		0.59 0.9 1.35 1.65	V
V _{OH}	Minimum High-Level Serial Output Only Output Voltage V _{IN} = V _{IH} or V _{IL}	V _{IN} = V _{IH} or V _{IL} I _{OH} = -50 μA	2.0 3.0 4.5	1.9 2.9 4.4	2.0 3.0 4.5		1.9 2.9 4.4		1.9 2.9 4.4		V
		V _{IN} = V _{IH} or V _{IL} I _{OH} = -4 mA I _{OH} = -8 mA	3.0 4.5	2.58 3.94			2.48 3.80		2.34 3.66		
V _{OL}	Maximum Low-Level Output Voltage V _{IN} = V _{IH} or V _{IL}	I _{OL} = 50 μA	2.0 3.0 4.5		0.0 0.0 0.0	0.1 0.1 0.1		0.1 0.1 0.1		0.1 0.1 0.1	V
		I _{OL} = 4 mA I _{OL} = 8 mA	3.0 4.5			0.36 0.36		0.44 0.44		0.52 0.52	
V _{OL2}	Maximum Low-Level Output Voltage with Max. Load V _{IN} = V _{IH} or V _{IL}	I _{OL} = 20 mA I _{OL} = 25 mA	3.0 4.5		0.8 0.5	1.0 0.6		1.1 0.7		1.25 0.8	V
I _{IN}	Maximum Input Leakage Current	V _{IN} = 5.5 V or GND	0 to 5.5			±0.1		±1.0		±1.0	μA
I _{CC}	Maximum Quiescent Supply Current	V _{IN} = V _{CC} or GND	5.5			4.0		40.0		40.0	μA
I _{OZ}	Three-State Output Off-State Current QA-QH	V _{IN} = V _{IH} or V _{IL} V _{OUT} = V _{CC} or GND	5.5			±0.25		±2.5		±2.5	μA
I _{LKG}	Active (2) State Off Output Leakage Current QA-QH	V _{IN} = V _{IH} or V _{IL} V _{OUT} = V _{CC} or GND	5.5			±0.25		±2.5		±2.5	μA
I _{OFF}	Power Off Output Leakage All Outputs	V _{IN} = 0 or 5.5 V V _{OUT} = 5.5 V	0			±0.25		±2.5		±2.5	μA

NLSF595

AC ELECTRICAL CHARACTERISTICS (Input $t_r = t_f = 3.0$ ns)

Symbol	Parameter	Test Conditions	$T_A = 25^\circ\text{C}$			$T_A \leq 85^\circ\text{C}$		$T_A \leq 125^\circ\text{C}$		Units
			Min	Typ	Max	Min	Max	Min	Max	
f_{\max}	Maximum Clock Frequency (50% Duty Cycle)	$V_{CC} = 3.3 \pm 0.3$ V	80	150		70		70		MHz
		$V_{CC} = 5.0 \pm 0.5$ V	135	185		115		115		
t_{PLH} , t_{PHL}	Propagation Delay, SCK to SQH	$V_{CC} = 3.3 \pm 0.3$ V $C_L = 15$ pF $C_L = 50$ pF		8.8 11.3	13.0 16.5	1.0 1.0	15.0 18.5	1.0 1.0	15.0 18.5	ns
		$V_{CC} = 5.0 \pm 0.5$ V $C_L = 15$ pF $C_L = 50$ pF		6.2 7.7	8.2 10.2	1.0 1.0	9.4 11.4	1.0 1.0	9.4 11.4	
t_{PHL}	Propagation Delay, SCLR to SQH	$V_{CC} = 3.3 \pm 0.3$ V $C_L = 15$ pF $C_L = 50$ pF		8.4 10.9	12.8 16.3	1.0 1.0	13.7 17.2	1.0 1.0	13.7 17.2	ns
		$V_{CC} = 5.0 \pm 0.5$ V $C_L = 15$ pF $C_L = 50$ pF		5.9 7.4	8.0 10.0	1.0 1.0	9.1 11.1	1.0 1.0	9.1 11.1	
t_{PLZ}	Output Disable Time RCK to QA-QH Output Enable Time RCK to QA-QH	$V_{CC} = 3.3 \pm 0.3$ V $C_L = 15$ pF $C_L = 50$ pF		7.7 10.2	11.9 15.4	1.0 1.0	13.5 17.0	1.0 1.0	13.5 17.0	ns
		$V_{CC} = 5.0 \pm 0.5$ V $C_L = 15$ pF $C_L = 50$ pF		5.4 6.9	7.4 9.4	1.0 1.0	8.5 10.5	1.0 1.0	8.5 10.5	
t_{PZL}	Output Disable Time RCK to QA-QH Output Enable Time RCK to QA-QH	$V_{CC} = 3.3 \pm 0.3$ V $C_L = 15$ pF $C_L = 50$ pF		7.7 10.2	11.9 15.4	1.0 1.0	13.5 17.0	1.0 1.0	13.5 17.0	ns
		$V_{CC} = 5.0 \pm 0.5$ V $C_L = 15$ pF $C_L = 50$ pF		5.4 6.9	7.4 9.4	1.0 1.0	8.5 10.5	1.0 1.0	8.5 10.5	
t_{PZL}	Output Enable Time, OE to QA-QH	$V_{CC} = 3.3 \pm 0.3$ V $R_L = 1$ k Ω $C_L = 15$ pF $C_L = 50$ pF		7.5 9.0	11.5 15.0	1.0 1.0	13.5 17.0	1.0 1.0	13.5 17.0	ns
		$V_{CC} = 5.0 \pm 0.5$ V $R_L = 1$ k Ω $C_L = 15$ pF $C_L = 50$ pF		4.8 8.3	8.6 10.6	1.0 1.0	10.0 12.0	1.0 1.0	10.0 12.0	
t_{PLZ}	Output Disable Time, OE to QA-QH	$V_{CC} = 3.3 \pm 0.3$ V $R_L = 1$ k Ω $C_L = 50$ pF		12.1	15.7	1.0	16.2	1.0	16.2	ns
		$V_{CC} = 5.0 \pm 0.5$ V $R_L = 1$ k Ω $C_L = 50$ pF		7.6	10.3	1.0	11.0	1.0	11.0	
C_{IN}	Input Capacitance			4	10		10		10	pF
C_{OUT}	Three-State Output Capacitance (Output in High-Impedance State), QA-QH			6			10		10	pF

C_{PD}	Power Dissipation Capacitance (Note 2)	Typical @ 25°C, $V_{CC} = 5.0$ V		pF
		87		

2. C_{PD} is defined as the value of the internal equivalent capacitance which is calculated from the operating current consumption without load. Average operating current can be obtained by the equation: $I_{CC(OPR)} = C_{PD} \cdot V_{CC} \cdot f_{in} + I_{CC}$. C_{PD} is used to determine the no-load dynamic power consumption; $P_D = C_{PD} \cdot V_{CC}^2 \cdot f_{in} + I_{CC} \cdot V_{CC}$.

NOISE CHARACTERISTICS (Input $t_r = t_f = 3.0$ ns, $C_L = 50$ pF, $V_{CC} = 5.0$ V)

Symbol	Characteristic	$T_A = 25^\circ\text{C}$		Units
		Typ	Max	
V_{OLP}	Quiet Output Maximum Dynamic V_{OL}	0.8	1.0	V
V_{OLV}	Quiet Output Minimum Dynamic V_{OL}	-0.8	-1.0	V
V_{IHD}	Minimum High Level Dynamic Input Voltage		3.5	V
V_{ILD}	Maximum Low Level Dynamic Input Voltage		1.5	V

NLSF595

TIMING REQUIREMENTS (Input $t_r = t_f = 3.0\text{ns}$)

Symbol	Parameter	V _{CC} V	T _A = 25°C		T _A = - 40 to 85°C	T _A = - 55 to 125°C	Units
			Typ	Limit	Limit	Limit	
t _{su}	Setup Time, SI to SCK	3.3 5.0		3.5 3.0	3.5 3.0	3.5 3.0	ns
t _{su(H)}	Setup Time, SCK to RCK	3.3 5.0		8.0 5.0	8.5 5.0	8.5 5.0	ns
t _{su(L)}	Setup Time, $\overline{\text{SCLR}}$ to RCK	3.3 5.0		8.0 5.0	9.0 5.0	9.0 5.0	ns
t _h	Hold Time, SI to SCK	3.3 5.0		1.5 2.0	1.5 2.0	1.5 2.0	ns
t _{h(L)}	Hold Time, $\overline{\text{SCLR}}$ to RCK	3.3 5.0		0 0	0 0	1.0 1.0	ns
t _{rec}	Recovery Time, $\overline{\text{SCLR}}$ to SCK	3.3 5.0		3.0 2.5	3.0 2.5	3.0 2.5	ns
t _w	Pulse Width, SCK or RCK	3.3 5.0		5.0 5.0	5.0 5.0	5.0 5.0	ns
t _{w(L)}	Pulse Width, $\overline{\text{SCLR}}$	3.3 5.0		5.0 5.0	5.0 5.0	5.0 5.0	ns

NLSF595

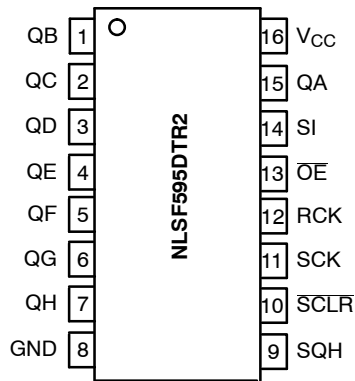
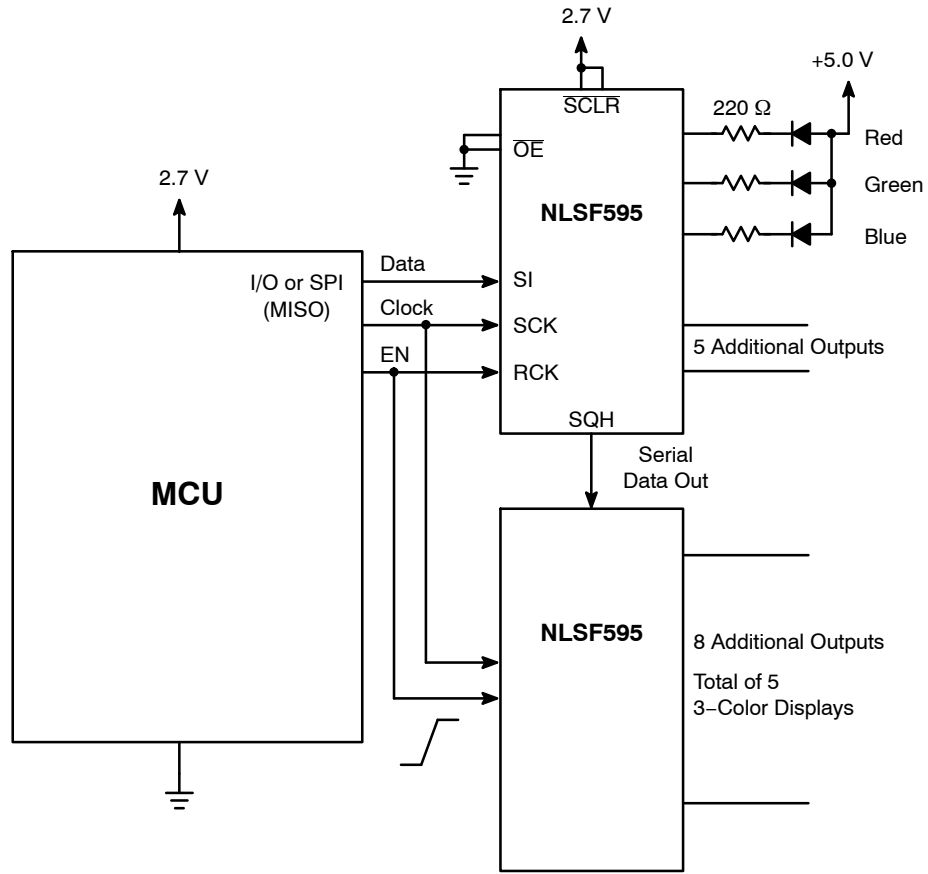

Figure 5. NLSF595 Shown Driving 5 3-Color LEDs

NLSF595

SWITCHING WAVEFORMS

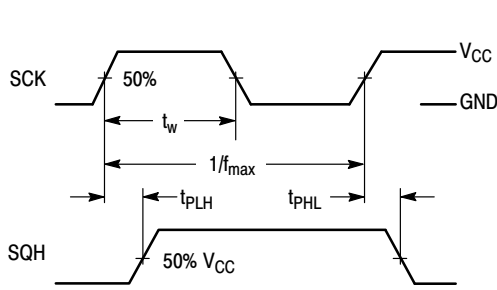

Figure 6.

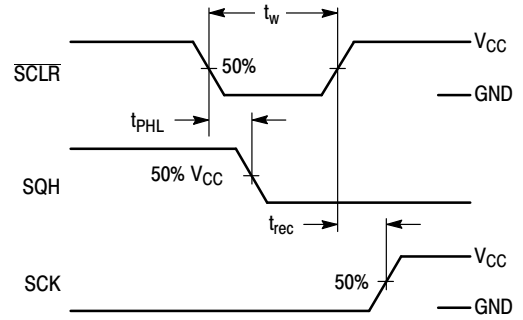

Figure 7.

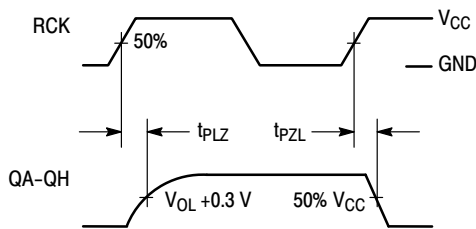

Figure 8.

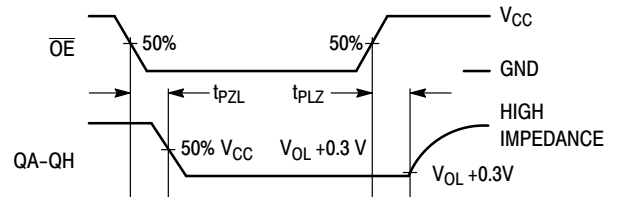

Figure 9.

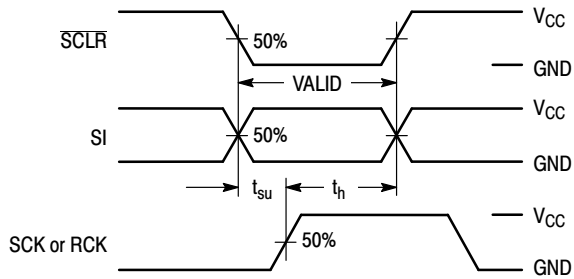

Figure 10.

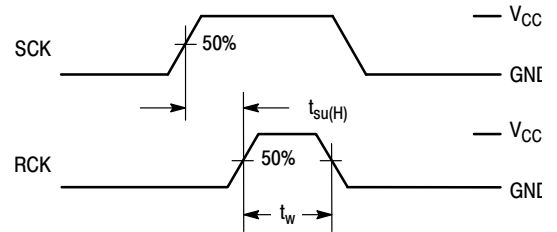
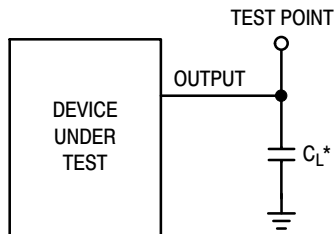

Figure 11.

TEST CIRCUITS



*Includes all probe and jig capacitance

Figure 12.

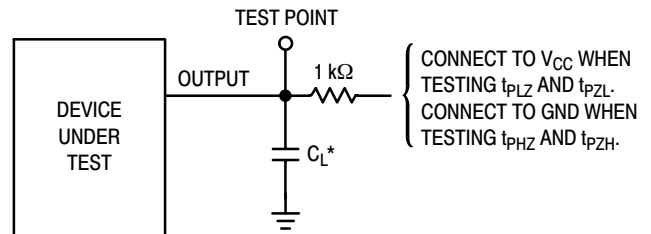

*Includes all probe and jig capacitance

Figure 13.

NLSF595

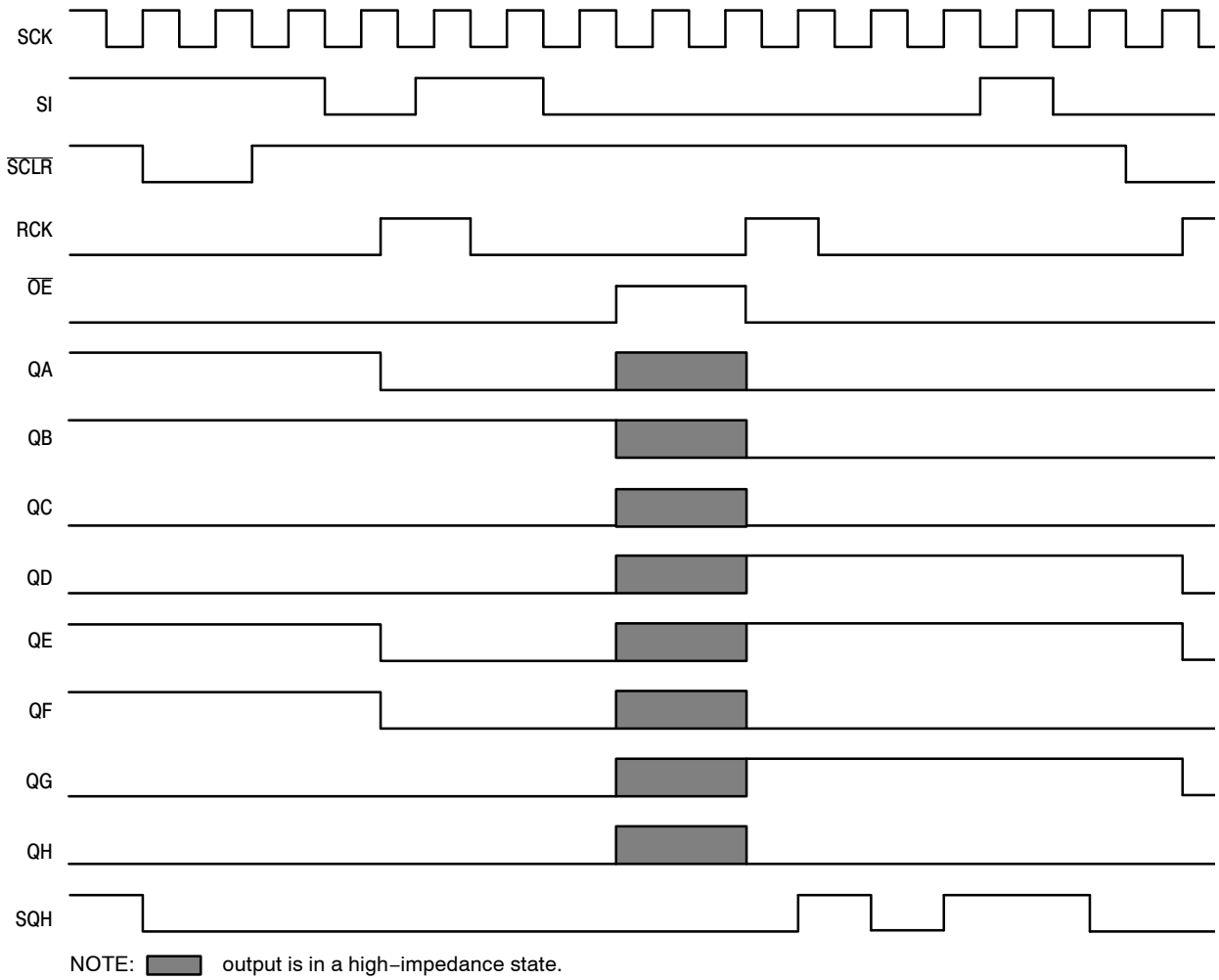

Figure 14. Timing Diagram

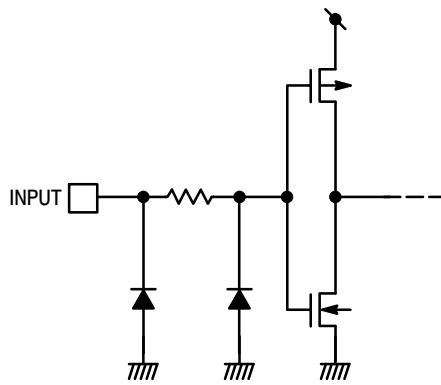

Figure 15. Input Equivalent Circuit

NLSF595

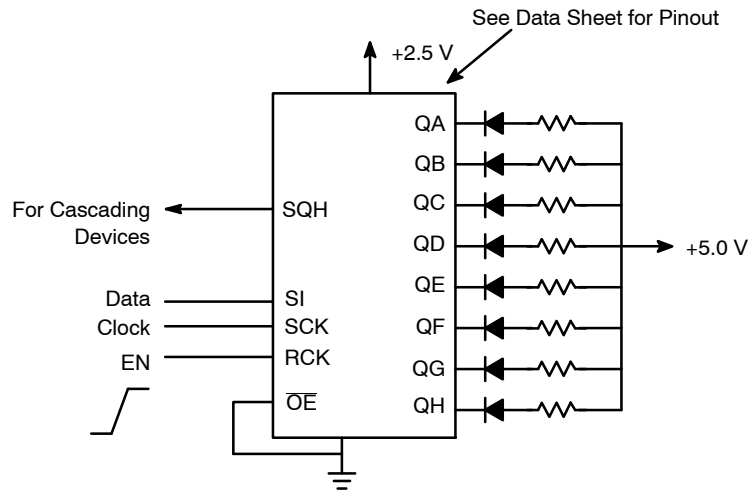
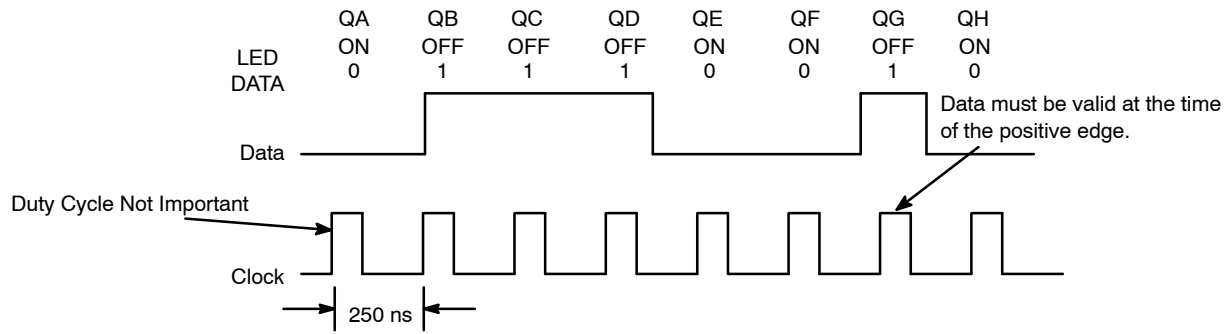

Figure 16. NLSF595 Example

NLSF595

ORDERING INFORMATION

Device Order Number	Device Nomenclature					Package	Shipping [†]
	Circuit Indicator	Technology	Device Function	Package Suffix	Tape & Reel Suffix		
NLSF595MNR2G	NL	SF	595	MN	R2	QFN (Pb-Free)	13-inch/3000 Unit
NLSF595DTR2G	NL	SF	595	DT	R2	TSSOP* (Pb-Free)	13-inch/2500 Unit

†For information on tape and reel specifications, including part orientation and tape sizes, please refer to our Tape and Reel Packaging Specifications Brochure, BRD8011/D.

*This package is inherently Pb-Free.

NLSF595

PACKAGE DIMENSIONS

QFN16 3x3, 0.5P
CASE 485G-01
ISSUE F

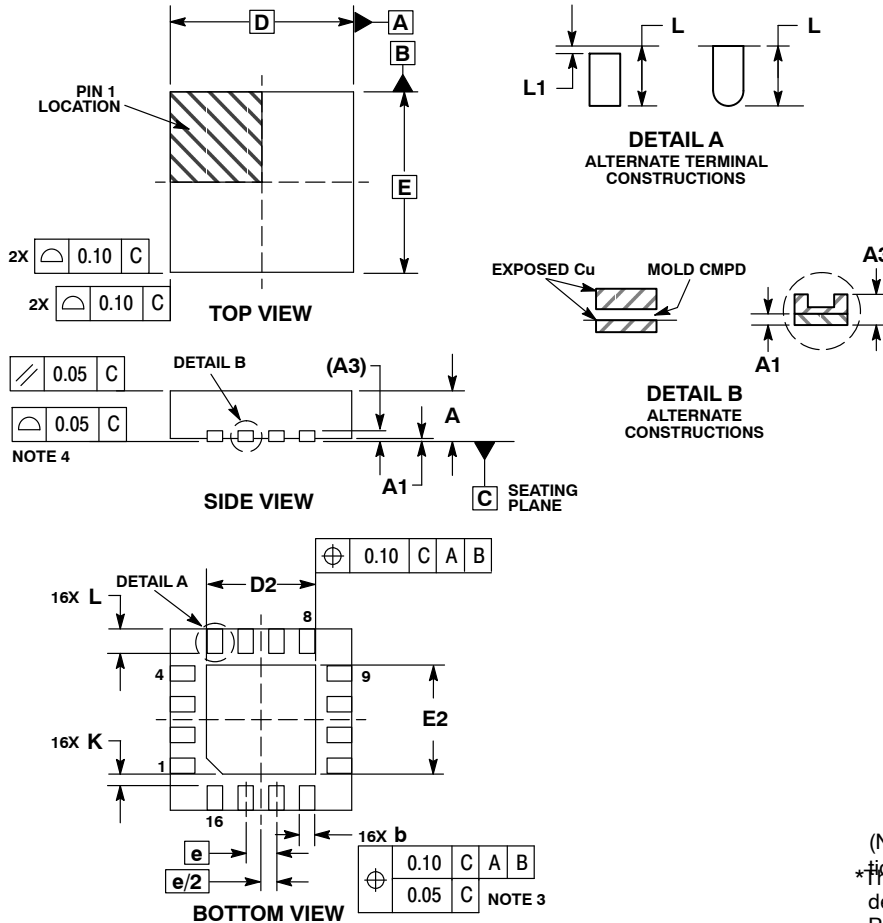

NOTES:

1. DIMENSIONING AND TOLERANCING PER ASME Y14.5M, 1994.
2. CONTROLLING DIMENSION: MILLIMETERS.
3. DIMENSION b APPLIES TO PLATED TERMINAL AND IS MEASURED BETWEEN 0.25 AND 0.30 MM FROM TERMINAL.
4. COPLANARITY APPLIES TO THE EXPOSED PAD AS WELL AS THE TERMINALS.

MILLIMETERS			
DIM	MIN	NOM	MAX
A	0.80	0.90	1.00
A1	0.00	0.03	0.05
A3	0.20 REF		
b	0.18	0.24	0.30
D	3.00 BSC		
D2	1.65	1.75	1.85
E	3.00 BSC		
E2	1.65	1.75	1.85
e	0.50 BSC		
K	0.18 TYP		
L	0.30	0.40	0.50
L1	0.00	0.08	0.15

GENERIC MARKING DIAGRAM*

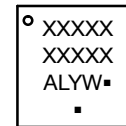

- XXXXX = Specific Device Code
- A = Assembly Location
- L = Wafer Lot
- Y = Year
- W = Work Week
- = Pb-Free Package

(Note: Microdot may be in either location)

*This information is generic. Please refer to device data sheet for actual part marking. Pb-Free indicator, "G" or microdot "▪", may or may not be present.

RECOMMENDED SOLDERING FOOTPRINT*

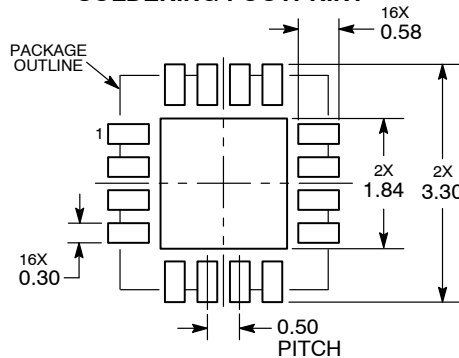

DIMENSIONS: MILLIMETERS

*For additional information on our Pb-Free strategy and soldering details, please download the ON Semiconductor Soldering and Mounting Techniques Reference Manual, SOLDERRM/D.

NLSF595

PACKAGE DIMENSIONS

TSSOP-16
CASE 948F-01
ISSUE B

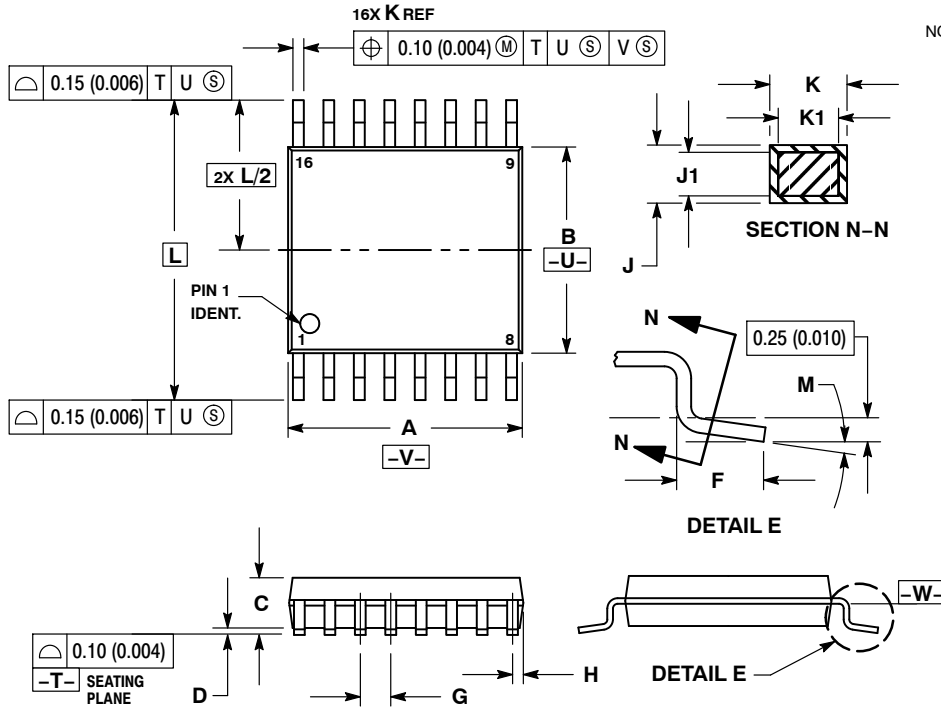

NOTES:

1. DIMENSIONING AND TOLERANCING PER ANSI Y14.5M, 1982.
2. CONTROLLING DIMENSION: MILLIMETER.
3. DIMENSION A DOES NOT INCLUDE MOLD FLASH, PROTRUSIONS OR GATE BURRS. MOLD FLASH OR GATE BURRS SHALL NOT EXCEED 0.15 (0.006) PER SIDE.
4. DIMENSION B DOES NOT INCLUDE INTERLEAD FLASH OR PROTRUSION. INTERLEAD FLASH OR PROTRUSION SHALL NOT EXCEED 0.25 (0.010) PER SIDE.
5. DIMENSION K DOES NOT INCLUDE DAMBAR PROTRUSION. ALLOWABLE DAMBAR PROTRUSION SHALL BE 0.08 (0.003) TOTAL IN EXCESS OF THE K DIMENSION AT MAXIMUM MATERIAL CONDITION.
6. TERMINAL NUMBERS ARE SHOWN FOR REFERENCE ONLY.
7. DIMENSION A AND B ARE TO BE DETERMINED AT DATUM PLANE -W-

DIM	MILLIMETERS		INCHES	
	MIN	MAX	MIN	MAX
A	4.90	5.10	0.193	0.200
B	4.30	4.50	0.169	0.177
C	---	1.20	---	0.047
D	0.05	0.15	0.002	0.006
F	0.50	0.75	0.020	0.030
G	0.65 BSC		0.026 BSC	
H	0.18	0.28	0.007	0.011
J	0.09	0.20	0.004	0.008
J1	0.09	0.16	0.004	0.006
K	0.19	0.30	0.007	0.012
K1	0.19	0.25	0.007	0.010
L	6.40 BSC		0.252 BSC	
M	0°	8°	0°	8°

SOLDERING FOOTPRINT

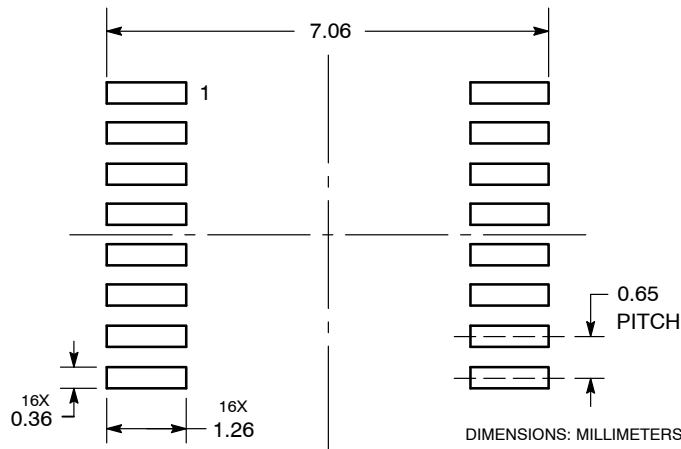

ON Semiconductor and are registered trademarks of Semiconductor Components Industries, LLC (SCILLC). SCILLC reserves the right to make changes without further notice to any products herein. SCILLC makes no warranty, representation or guarantee regarding the suitability of its products for any particular purpose, nor does SCILLC assume any liability arising out of the application or use of any product or circuit, and specifically disclaims any and all liability, including without limitation special, consequential or incidental damages. "Typical" parameters which may be provided in SCILLC data sheets and/or specifications can and do vary in different applications and actual performance may vary over time. All operating parameters, including "Typicals" must be validated for each customer application by customer's technical experts. SCILLC does not convey any license under its patent rights nor the rights of others. SCILLC products are not designed, intended, or authorized for use as components in systems intended for surgical implant into the body, or other applications intended to support or sustain life, or for any other application in which the failure of the SCILLC product could create a situation where personal injury or death may occur. Should Buyer purchase or use SCILLC products for any such unintended or unauthorized application, Buyer shall indemnify and hold SCILLC and its officers, employees, subsidiaries, affiliates, and distributors harmless against all claims, costs, damages, and expenses, and reasonable attorney fees arising out of, directly or indirectly, any claim of personal injury or death associated with such unintended or unauthorized use, even if such claim alleges that SCILLC was negligent regarding the design or manufacture of the part. SCILLC is an Equal Opportunity/Affirmative Action Employer. This literature is subject to all applicable copyright laws and is not for resale in any manner.

PUBLICATION ORDERING INFORMATION

LITERATURE FULFILLMENT:
Literature Distribution Center for ON Semiconductor
P.O. Box 5163, Denver, Colorado 80217 USA
Phone: 303-675-2175 or 800-344-3860 Toll Free USA/Canada
Fax: 303-675-2176 or 800-344-3867 Toll Free USA/Canada
Email: orderlit@onsemi.com

N. American Technical Support: 800-282-9855 Toll Free
USA/Canada
Europe, Middle East and Africa Technical Support:
Phone: 421 33 790 2910
Japan Customer Focus Center
Phone: 81-3-5773-3850

ON Semiconductor Website: www.onsemi.com
Order Literature: <http://www.onsemi.com/orderlit>
For additional information, please contact your local Sales Representative

Looking for pricing, stock, or lifecycle information?

Click below to explore more details on WIN SOURCE:

- ⊖ [View NLSF595MNR2G on WIN SOURCE](#)
- ⊖ [ON Semiconductor Information](#)

Optimize Your Supply Chain with WIN SOURCE Solutions

- ✓ Global Sourcing Solution
- ✓ Obsolete Management
- ✓ Cost Control Management
- ✓ Shortage Management
- ✓ Alternative Solution
- ✓ Excess Inventory Management