



**THE DATASHEET OF  
NTSB30100CTT4G**



# NTST30100CTG, NTSB30100CT-1G, NTSJ30100CTG, NTSB30100CTG

## Very Low Forward Voltage Trench-based Schottky Rectifier

Exceptionally Low  $V_F = 0.455\text{ V}$  at  $I_F = 5\text{ A}$

### Features

- Fine Lithography Trench-based Schottky Technology for Very Low Forward Voltage and Low Leakage
- Fast Switching with Exceptional Temperature Stability
- Low Power Loss and Lower Operating Temperature
- Higher Efficiency for Achieving Regulatory Compliance
- Low Thermal Resistance
- High Surge Capability
- These are Pb-Free Devices

### Typical Applications

- Switching Power Supplies including Notebook / Netbook Adapters, ATX and Flat Panel Display
- High Frequency and DC-DC Converters
- Freewheeling and OR-ing diodes
- Reverse Battery Protection
- Instrumentation

### Mechanical Characteristics

- Case: Epoxy, Molded
- Epoxy Meets Flammability Rating UL 94-0 @ 0.125 in
- Finish: All External Surfaces Corrosion Resistant and Terminal Leads are Readily Solderable
- Lead Temperature for Soldering Purposes: 260°C Maximum for 10 sec



ON Semiconductor®

[www.onsemi.com](http://www.onsemi.com)

### PIN CONNECTIONS

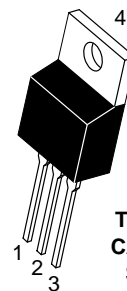
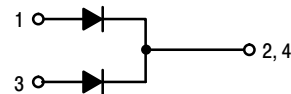

TO-220AB  
CASE 221A  
STYLE 6

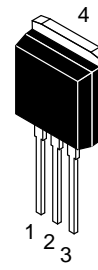

I2PAK  
CASE 418D  
STYLE 3

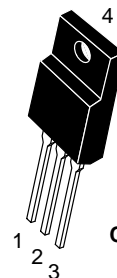

TO-220FP  
CASE 221AH

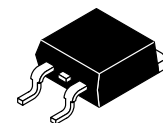

D2PAK  
CASE 418B

### ORDERING INFORMATION

See detailed ordering and shipping information in the package dimensions section on page 5 of this data sheet.

# NTST30100CTG, NTSB30100CT-1G, NTSJ30100CTG, NTSB30100CTG

## MAXIMUM RATINGS

| Rating   | Symbol                                 | Value       | Unit             |
|--|--|-------------|------------------|
| Peak Repetitive Reverse Voltage<br>Working Peak Reverse Voltage<br>DC Blocking Voltage                     | $V_{RRM}$<br>$V_{RWM}$<br>$V_R$        | 100         | V                |
| Average Rectified Forward Current<br>(Rated $V_R$ , $T_C = 115^\circ\text{C}$ )                            | $I_{F(AV)}$<br>Per device<br>Per diode | 30<br>15    | A                |
| Peak Repetitive Forward Current<br>(Rated $V_R$ , Square Wave, 20 kHz, $T_C = 110^\circ\text{C}$ )         | $I_{FRM}$<br>Per device<br>Per diode   | 60<br>30    | A                |
| Nonrepetitive Peak Surge Current<br>(Surge applied at rated load conditions halfwave, single phase, 60 Hz) | $I_{FSM}$                              | 160         | A                |
| Operating Junction Temperature   | $T_J$                                  | -40 to +150 | $^\circ\text{C}$ |
| Storage Temperature  | $T_{stg}$                              | -40 to +150 | $^\circ\text{C}$ |
| Voltage Rate of Change (Rated $V_R$ )  | dv/dt                                  | 10,000      | V/ $\mu\text{s}$ |

Stresses exceeding those listed in the Maximum Ratings table may damage the device. If any of these limits are exceeded, device functionality should not be assumed, damage may occur and reliability may be affected.

## THERMAL CHARACTERISTICS

| Rating  | Symbol                             | NTST30100CTG,<br>NTSB30100CT-1G | NTSB30100CTG | NTSJ30100CTG | Unit                                     |
|---|------------------------------------|---------------------------------|--------------|--------------|--|
| Maximum Thermal Resistance per Diode<br>Junction-to-Case<br>Junction-to-Ambient | $R_{\theta JC}$<br>$R_{\theta JA}$ | 2.5<br>70                       | 1.14<br>46.6 | 4.09<br>105  | $^\circ\text{C/W}$<br>$^\circ\text{C/W}$ |

## ELECTRICAL CHARACTERISTICS (Per Leg unless otherwise noted)

| Rating  | Symbol | Typ  | Max                                  | Unit   |
|---|--------|--|--------------------------------------|--|
| Maximum Instantaneous Forward Voltage (Note 1)<br>( $I_F = 5\text{ A}$ , $T_J = 25^\circ\text{C}$ )<br>( $I_F = 7.5\text{ A}$ , $T_J = 25^\circ\text{C}$ )<br>( $I_F = 15\text{ A}$ , $T_J = 25^\circ\text{C}$ )<br><br>( $I_F = 5\text{ A}$ , $T_J = 125^\circ\text{C}$ )<br>( $I_F = 7.5\text{ A}$ , $T_J = 125^\circ\text{C}$ )<br>( $I_F = 15\text{ A}$ , $T_J = 125^\circ\text{C}$ ) | $V_F$  | 0.516<br>0.576<br>0.734<br><br>0.455<br>0.522<br>0.627 | -<br>-<br>0.85<br><br>-<br>-<br>0.68 | V  |
| Maximum Instantaneous Reverse Current (Note 1)<br>( $V_R = 70\text{ V}$ , $T_J = 25^\circ\text{C}$ )<br>( $V_R = 70\text{ V}$ , $T_J = 125^\circ\text{C}$ )<br><br>(Rated dc Voltage, $T_J = 25^\circ\text{C}$ )<br>(Rated dc Voltage, $T_J = 125^\circ\text{C}$ )  | $I_R$  | 7.2<br>8.0<br><br>65<br>20                             | <br><br><br>500<br>35                | $\mu\text{A}$<br>mA<br><br>$\mu\text{A}$<br>mA |

Product parametric performance is indicated in the Electrical Characteristics for the listed test conditions, unless otherwise noted. Product performance may not be indicated by the Electrical Characteristics if operated under different conditions.

1. Pulse Test: Pulse Width = 300  $\mu\text{s}$ , Duty Cycle  $\leq 2.0\%$

TYPICAL CHARACTERISTICS

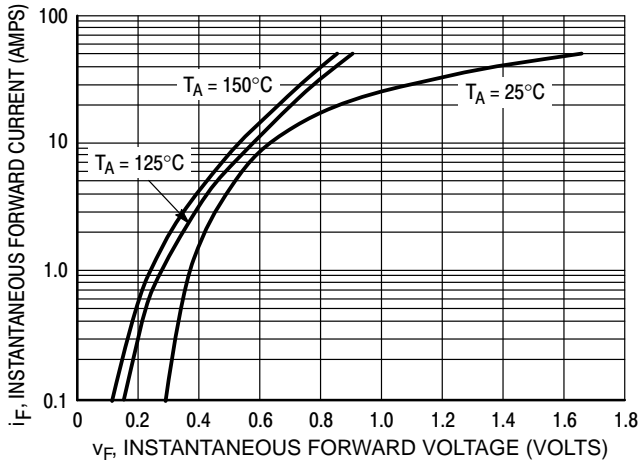

Figure 1. Typical Forward Voltage

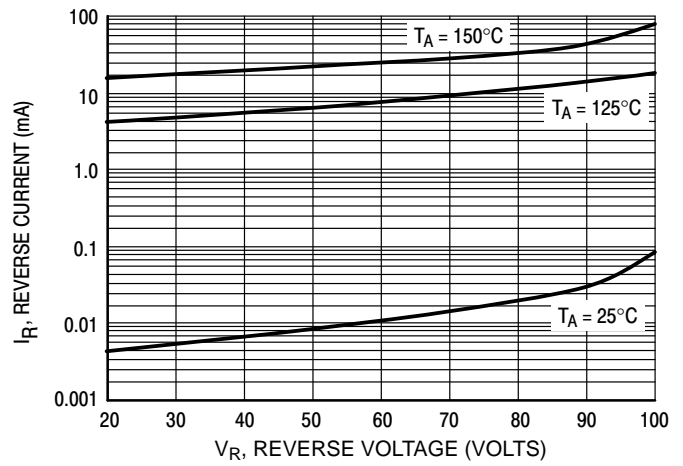

Figure 2. Typical Reverse Current

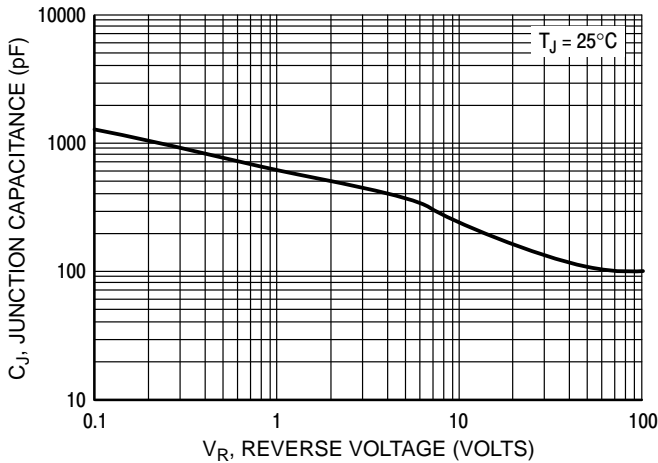

Figure 3. Typical Junction Capacitance

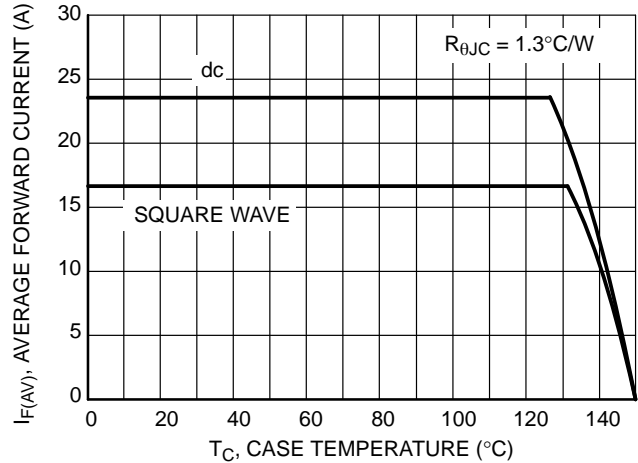

Figure 4. Current Derating per Leg

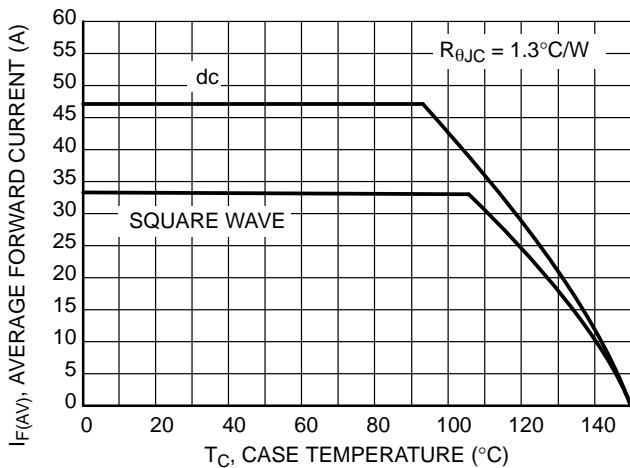

Figure 5. Current Derating

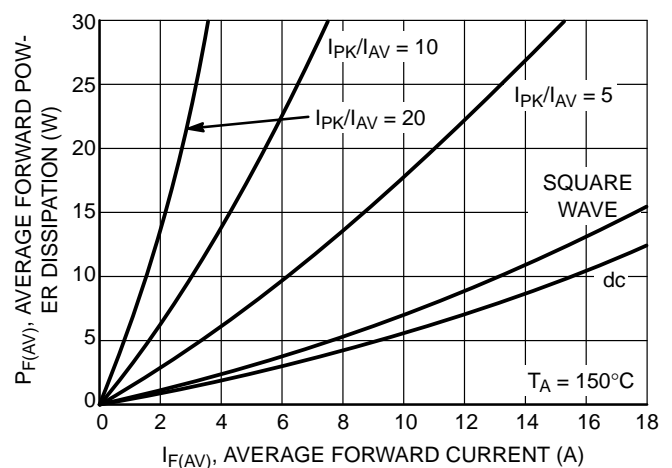

Figure 6. Forward Power Dissipation

TYPICAL CHARACTERISTICS

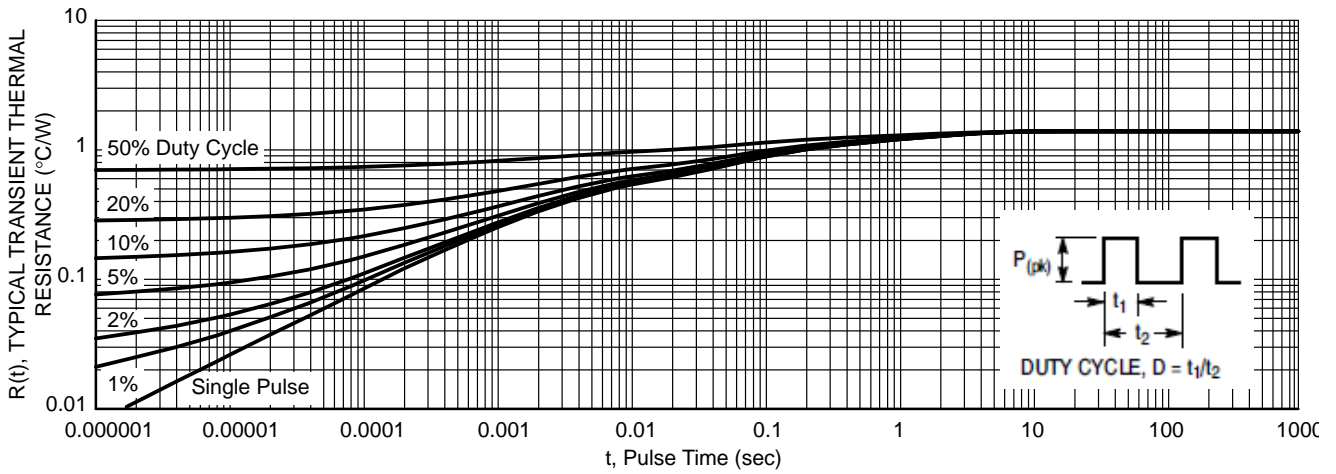

Figure 7. Typical Transient Thermal Response, Junction-to-Case for NTST30100CT and NTSB30100CT-1G

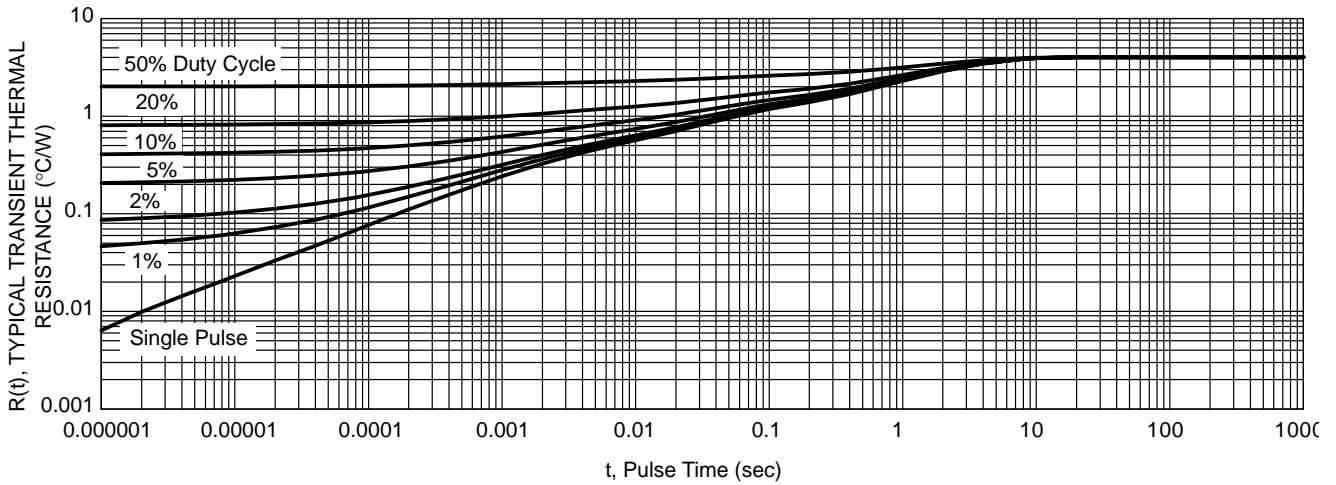

Figure 8. Typical Transient Thermal Response, Junction-to-Case for NTSJ30100CTG

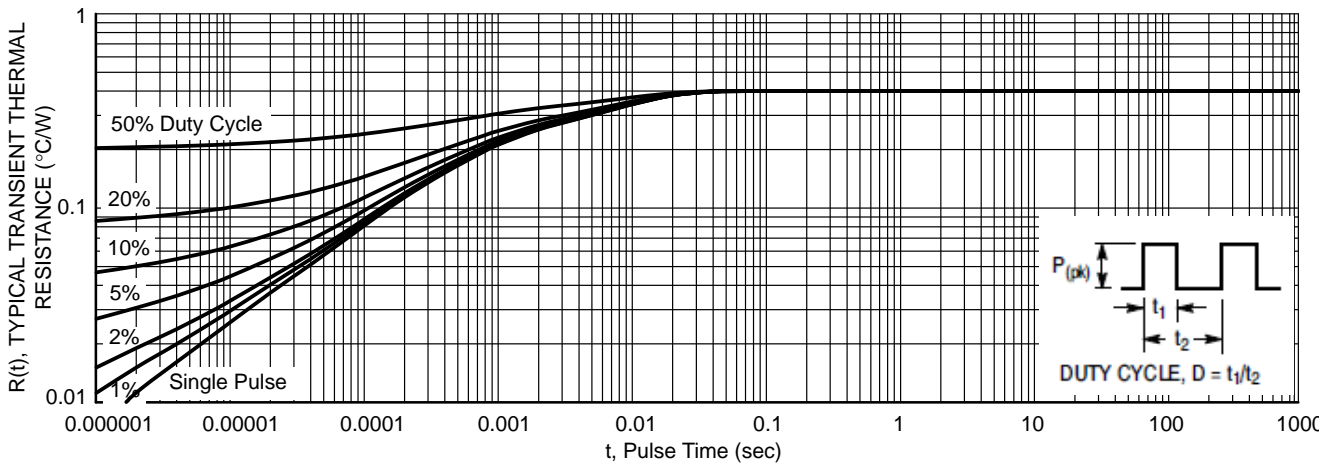

Figure 9. Typical Transient Thermal Response, Junction-to-Case for NTSB30100CTG

# NTST30100CTG, NTSB30100CT-1G, NTSJ30100CTG, NTSB30100CTG

## ORDERING INFORMATION

| Device         | Package                         | Shipping          |
|----------------|---------------------------------|-------------------|
| NTST30100CTG   | TO-220AB<br>(Pb-Free)           | 50 Units / Rail   |
| NTSB30100CT-1G | I <sup>2</sup> PAK<br>(Pb-Free) | 50 Units / Rail   |
| NTSJ30100CTG   | TO-220FP<br>(Halide-Free)       | 50 Units / Rail   |
| NTSB30100CTG   | D <sup>2</sup> PAK<br>(Pb-Free) | 50 Units / Rail   |
| NTSB30100CTT4G | D <sup>2</sup> PAK<br>(Pb-Free) | 800 / Tape & Reel |

## MARKING DIAGRAMS

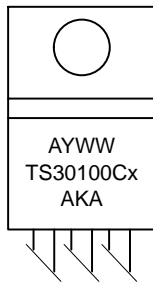

TO-220AB

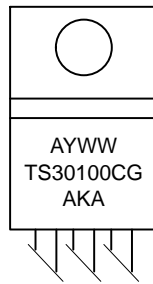

TO-220FP

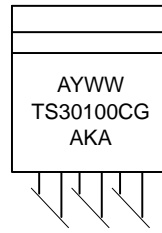

I<sup>2</sup>PAK

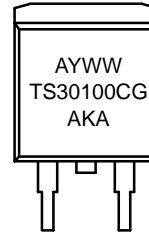

D<sup>2</sup>PAK

- A = Assembly Location
- Y = Year
- WW = Work Week
- AKA = Polarity Designator
- x = G or H
- G = Pb-Free Package
- H = Halide-Free Package

PACKAGE DIMENSIONS

TO-220  
CASE 221A-09  
ISSUE AH

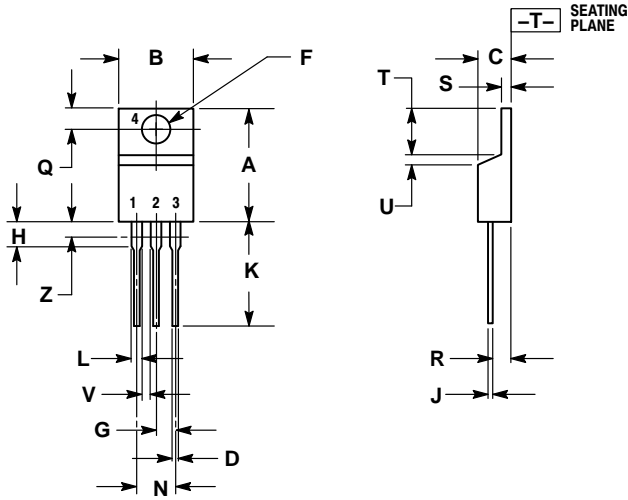

- NOTES:
1. DIMENSIONING AND TOLERANCING PER ANSI Y14.5M, 1982.
  2. CONTROLLING DIMENSION: INCH.
  3. DIMENSION Z DEFINES A ZONE WHERE ALL BODY AND LEAD IRREGULARITIES ARE ALLOWED.

| DIM | INCHES |       | MILLIMETERS |       |
|-----|--------|-------|-------------|-------|
|     | MIN    | MAX   | MIN         | MAX   |
| A   | 0.570  | 0.620 | 14.48       | 15.75 |
| B   | 0.380  | 0.415 | 9.66        | 10.53 |
| C   | 0.160  | 0.190 | 4.07        | 4.83  |
| D   | 0.025  | 0.038 | 0.64        | 0.96  |
| F   | 0.142  | 0.161 | 3.61        | 4.09  |
| G   | 0.095  | 0.105 | 2.42        | 2.66  |
| H   | 0.110  | 0.161 | 2.80        | 4.10  |
| J   | 0.014  | 0.024 | 0.36        | 0.61  |
| K   | 0.500  | 0.562 | 12.70       | 14.27 |
| L   | 0.045  | 0.060 | 1.15        | 1.52  |
| N   | 0.190  | 0.210 | 4.83        | 5.33  |
| Q   | 0.100  | 0.120 | 2.54        | 3.04  |
| R   | 0.080  | 0.110 | 2.04        | 2.79  |
| S   | 0.045  | 0.055 | 1.15        | 1.39  |
| T   | 0.235  | 0.255 | 5.97        | 6.47  |
| U   | 0.000  | 0.050 | 0.00        | 1.27  |
| V   | 0.045  | ---   | 1.15        | ---   |
| Z   | ---    | 0.080 | ---         | 2.04  |

- STYLE 6:
1. ANODE
  2. CATHODE
  3. ANODE
  4. CATHODE

I<sup>2</sup>PAK (TO-262)  
CASE 418D  
ISSUE D

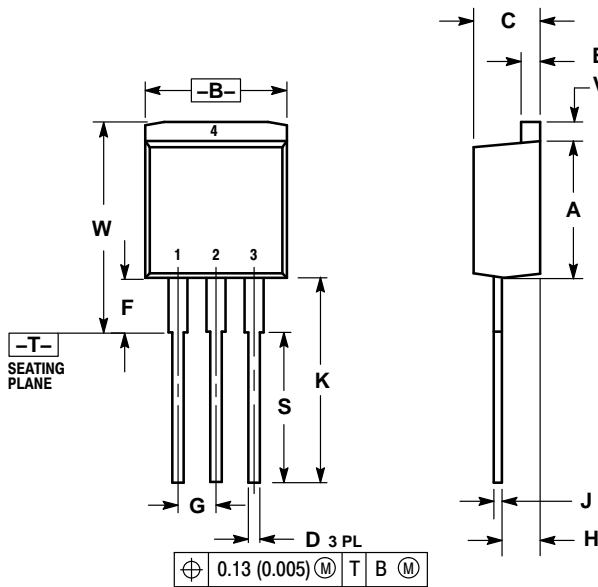

- NOTES:
1. DIMENSIONING AND TOLERANCING PER ANSI Y14.5M, 1982.
  2. CONTROLLING DIMENSION: INCH.

| DIM | INCHES    |       | MILLIMETERS |       |
|-----|-----------|-------|-------------|-------|
|     | MIN       | MAX   | MIN         | MAX   |
| A   | 0.335     | 0.380 | 8.51        | 9.65  |
| B   | 0.380     | 0.406 | 9.65        | 10.31 |
| C   | 0.160     | 0.185 | 4.06        | 4.70  |
| D   | 0.026     | 0.035 | 0.66        | 0.89  |
| E   | 0.045     | 0.055 | 1.14        | 1.40  |
| F   | 0.122 REF |       | 3.10 REF    |       |
| G   | 0.100 BSC |       | 2.54 BSC    |       |
| H   | 0.094     | 0.110 | 2.39        | 2.79  |
| J   | 0.013     | 0.025 | 0.33        | 0.64  |
| K   | 0.500     | 0.562 | 12.70       | 14.27 |
| S   | 0.390 REF |       | 9.90 REF    |       |
| V   | 0.045     | 0.070 | 1.14        | 1.78  |
| W   | 0.522     | 0.551 | 13.25       | 14.00 |

PACKAGE DIMENSIONS

TO-220 FULLPACK, 3-LEAD  
CASE 221AH  
ISSUE F

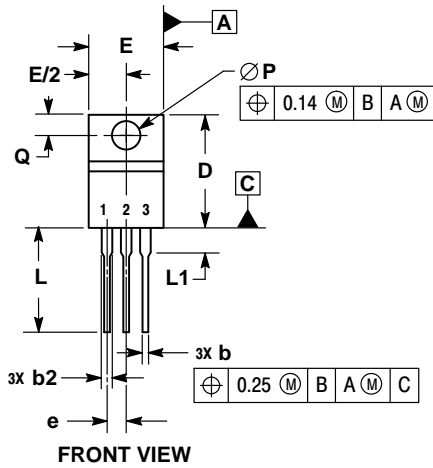

FRONT VIEW

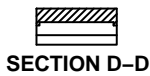

SECTION D-D

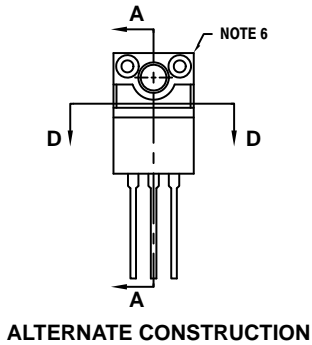

ALTERNATE CONSTRUCTION

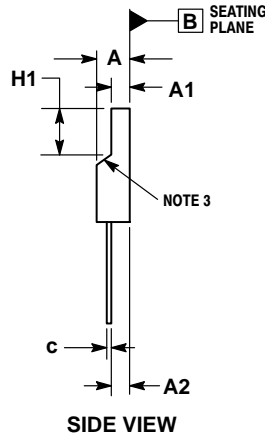

SIDE VIEW

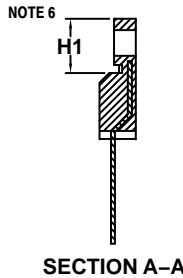

SECTION A-A

NOTES:

1. DIMENSIONING AND TOLERANCING PER ASME Y14.5M, 1994.
2. CONTROLLING DIMENSION: MILLIMETERS.
3. CONTOUR UNCONTROLLED IN THIS AREA.
4. DIMENSIONS D AND E DO NOT INCLUDE MOLD FLASH AND GATE PROTRUSIONS. MOLD FLASH AND GATE PROTRUSIONS NOT TO EXCEED 0.13 PER SIDE. THESE DIMENSIONS ARE TO BE MEASURED AT OUTERMOST EXTREME OF THE PLASTIC BODY.
5. DIMENSION b2 DOES NOT INCLUDE DAMBAR PROTRUSION. LEAD WIDTH INCLUDING PROTRUSION SHALL NOT EXCEED 2.00.
6. CONTOURS AND FEATURES OF THE MOLDED PACKAGE BODY MAY VARY WITHIN THE ENVELOPE DEFINED BY DIMENSIONS A1 AND H1 FOR MANUFACTURING PURPOSES.

| MILLIMETERS |          |       |
|-------------|----------|-------|
| DIM         | MIN      | MAX   |
| A           | 4.30     | 4.70  |
| A1          | 2.50     | 2.90  |
| A2          | 2.50     | 2.90  |
| b           | 0.54     | 0.84  |
| b2          | 1.10     | 1.40  |
| c           | 0.49     | 0.79  |
| D           | 14.70    | 15.30 |
| E           | 9.70     | 10.30 |
| e           | 2.54 BSC |       |
| H1          | 6.60     | 7.10  |
| L           | 12.50    | 14.73 |
| L1          | ---      | 2.80  |
| P           | 3.00     | 3.40  |
| Q           | 2.80     | 3.20  |

PACKAGE DIMENSIONS

D<sup>2</sup>PAK 3  
CASE 418B-04  
ISSUE K

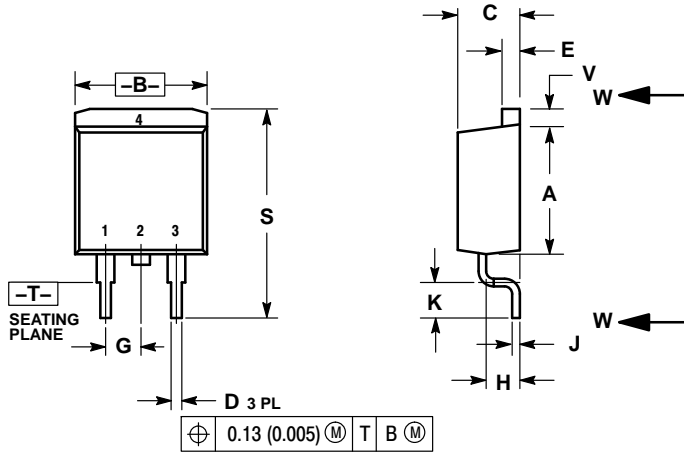

- NOTES:  
1. DIMENSIONING AND TOLERANCING PER ANSI Y14.5M, 1982.  
2. CONTROLLING DIMENSION: INCH.  
3. 418B-01 THRU 418B-03 OBSOLETE, NEW STANDARD 418B-04.

| DIM | INCHES    |       | MILLIMETERS |       |
|-----|-----------|-------|-------------|-------|
|     | MIN       | MAX   | MIN         | MAX   |
| A   | 0.340     | 0.380 | 8.64        | 9.65  |
| B   | 0.380     | 0.405 | 9.65        | 10.29 |
| C   | 0.160     | 0.190 | 4.06        | 4.83  |
| D   | 0.020     | 0.035 | 0.51        | 0.89  |
| E   | 0.045     | 0.055 | 1.14        | 1.40  |
| F   | 0.310     | 0.350 | 7.87        | 8.89  |
| G   | 0.100 BSC |       | 2.54 BSC    |       |
| H   | 0.080     | 0.110 | 2.03        | 2.79  |
| J   | 0.018     | 0.025 | 0.46        | 0.64  |
| K   | 0.090     | 0.110 | 2.29        | 2.79  |
| L   | 0.052     | 0.072 | 1.32        | 1.83  |
| M   | 0.280     | 0.320 | 7.11        | 8.13  |
| N   | 0.197 REF |       | 5.00 REF    |       |
| P   | 0.079 REF |       | 2.00 REF    |       |
| R   | 0.039 REF |       | 0.99 REF    |       |
| S   | 0.575     | 0.625 | 14.60       | 15.88 |
| V   | 0.045     | 0.055 | 1.14        | 1.40  |

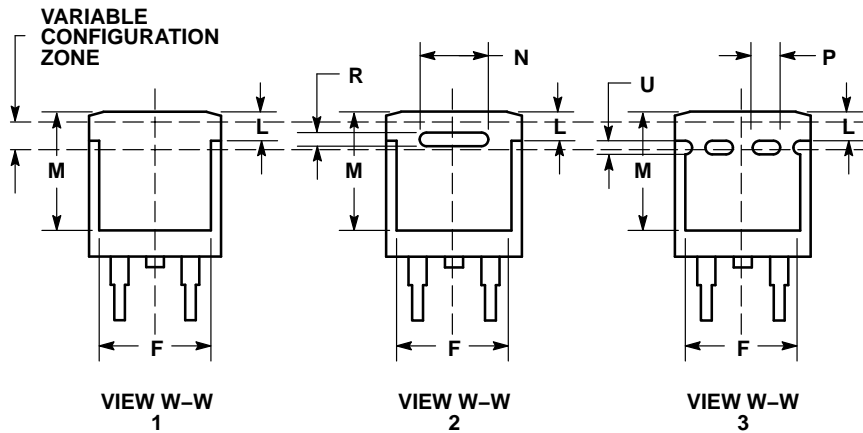

ON Semiconductor and are trademarks of Semiconductor Components Industries, LLC dba ON Semiconductor or its subsidiaries in the United States and/or other countries. ON Semiconductor owns the rights to a number of patents, trademarks, copyrights, trade secrets, and other intellectual property. A listing of ON Semiconductor's product/patent coverage may be accessed at [www.onsemi.com/site/pdf/Patent-Marking.pdf](http://www.onsemi.com/site/pdf/Patent-Marking.pdf). ON Semiconductor reserves the right to make changes without further notice to any products herein. ON Semiconductor makes no warranty, representation or guarantee regarding the suitability of its products for any particular purpose, nor does ON Semiconductor assume any liability arising out of the application or use of any product or circuit, and specifically disclaims any and all liability, including without limitation special, consequential or incidental damages. Buyer is responsible for its products and applications using ON Semiconductor products, including compliance with all laws, regulations and safety requirements or standards, regardless of any support or applications information provided by ON Semiconductor. "Typical" parameters which may be provided in ON Semiconductor data sheets and/or specifications can and do vary in different applications and actual performance may vary over time. All operating parameters, including "Typicals" must be validated for each customer application by customer's technical experts. ON Semiconductor does not convey any license under its patent rights nor the rights of others. ON Semiconductor products are not designed, intended, or authorized for use as a critical component in life support systems or any FDA Class 3 medical devices or medical devices with a same or similar classification in a foreign jurisdiction or any devices intended for implantation in the human body. Should Buyer purchase or use ON Semiconductor products for any such unintended or unauthorized application, Buyer shall indemnify and hold ON Semiconductor and its officers, employees, subsidiaries, affiliates, and distributors harmless against all claims, costs, damages, and expenses, and reasonable attorney fees arising out of, directly or indirectly, any claim of personal injury or death associated with such unintended or unauthorized use, even if such claim alleges that ON Semiconductor was negligent regarding the design or manufacture of the part. ON Semiconductor is an Equal Opportunity/Affirmative Action Employer. This literature is subject to all applicable copyright laws and is not for resale in any manner.

PUBLICATION ORDERING INFORMATION

LITERATURE FULFILLMENT:  
Literature Distribution Center for ON Semiconductor  
19521 E. 32nd Pkwy, Aurora, Colorado 80011 USA  
Phone: 303-675-2175 or 800-344-3860 Toll Free USA/Canada  
Fax: 303-675-2176 or 800-344-3867 Toll Free USA/Canada  
Email: [orderlit@onsemi.com](mailto:orderlit@onsemi.com)

N. American Technical Support: 800-282-9855 Toll Free  
USA/Canada  
Europe, Middle East and Africa Technical Support:  
Phone: 421 33 790 2910  
Japan Customer Focus Center  
Phone: 81-3-5817-1050

ON Semiconductor Website: [www.onsemi.com](http://www.onsemi.com)  
Order Literature: <http://www.onsemi.com/orderlit>  
For additional information, please contact your local Sales Representative

## Looking for pricing, stock, or lifecycle information?

Click below to explore more details on WIN SOURCE:

- ⊖ [View NTSB30100CTT4G on WIN SOURCE](#)
- ⊖ [ON Semiconductor Information](#)

## Optimize Your Supply Chain with WIN SOURCE Solutions

- ✓ Global Sourcing Solution
- ✓ Obsolete Management
- ✓ Cost Control Management
- ✓ Shortage Management
- ✓ Alternative Solution
- ✓ Excess Inventory Management