

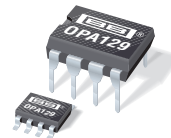

**THE DATASHEET OF
OPA129UB/2K5E4**





Ultra-Low Bias Current *Difet*[®] OPERATIONAL AMPLIFIER

FEATURES

- ULTRA-LOW BIAS CURRENT: 100fA max
- LOW OFFSET: 2mV max
- LOW DRIFT: 10 μ V/°C max
- HIGH OPEN-LOOP GAIN: 94dB min
- LOW NOISE: 15nV/ $\sqrt{\text{Hz}}$ at 10kHz
- PLASTIC DIP AND SO PACKAGES

DESCRIPTION

The OPA129 is an ultra-low bias current monolithic operational amplifier offered in an 8-pin PDIP and SO-8 package. Using advanced geometry dielectrically-isolated FET (*Difet*[®]) inputs, this monolithic amplifier achieves a high performance level.

Difet fabrication eliminates isolation-junction leakage current—the main contributor to input bias current with conventional monolithic FETs. This reduces input bias current by a factor of 10 to 100. Very low input bias current can be achieved without resorting to small-geometry FETs or CMOS designs which can suffer from much larger offset voltage, voltage noise, drift, and poor power-supply rejection.

The OPA129 special pinout eliminates leakage current that occurs with other op amps. Pins 1 and 4 have no internal connection, allowing circuit board guard traces—even with the surface-mount package version.

OPA129 is available in 8-pin DIP and SO packages, specified for operation from –40°C to +85°C.

APPLICATIONS

- PHOTODETECTOR PREAMPS
- CHROMATOGRAPHY
- ELECTROMETER AMPLIFIERS
- MASS SPECTROMETERS
- pH PROBE AMPLIFIERS
- ION GAGE MEASUREMENT

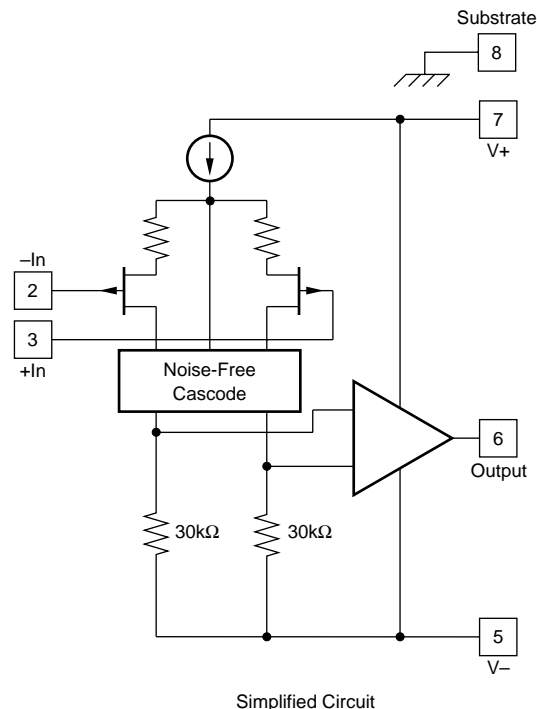

Please be aware that an important notice concerning availability, standard warranty, and use in critical applications of Texas Instruments semiconductor products and disclaimers thereto appears at the end of this data sheet.

Difet is a registered trademark of Texas Instruments.
All other trademarks are the property of their respective owners.

SPECIFICATIONS

ELECTRICAL

At $V_S = \pm 15V$ and $T_A = +25^\circ C$, unless otherwise noted. Pin 8 connected to ground.

PARAMETER	CONDITION	OPA129PB, UB			OPA129P, U			UNITS
		MIN	TYP	MAX	MIN	TYP	MAX	
INPUT BIAS CURRENT⁽¹⁾ vs Temperature	$V_{CM} = 0V$		± 30	± 100		*	± 250	fA
			Doubles every $10^\circ C$				*	
INPUT OFFSET CURRENT	$V_{CM} = 0V$		± 30			*		fA
OFFSET VOLTAGE Input Offset Voltage vs Temperature Supply Rejection	$V_{CM} = 0V$ $V_S = \pm 5V$ to $\pm 18V$		± 0.5 ± 3 ± 3	± 2 ± 10 ± 100		± 1 ± 5 *	± 5 *	mV $\mu V/^\circ C$ $\mu V/V$
NOISE Voltage	$f = 10Hz$ $f = 100Hz$ $f = 1kHz$ $f = 10kHz$ $f_B = 0.1Hz$ to $10Hz$		85 28 17 15			*		nV/\sqrt{Hz} nV/\sqrt{Hz} nV/\sqrt{Hz} nV/\sqrt{Hz}
Current	$f = 10kHz$		4 0.1			*		μV_{PP} fA/\sqrt{Hz}
INPUT IMPEDANCE Differential Common-Mode			$10^{13} \parallel 1$ $10^{15} \parallel 2$			*		$\Omega \parallel pF$ $\Omega \parallel pF$
VOLTAGE RANGE Common-Mode Input Range Common-Mode Rejection	$V_{IN} = \pm 10V$	± 10 80	± 12 118		*	*		V dB
OPEN-LOOP GAIN, DC Open-Loop Voltage Gain	$R_L \geq 2k\Omega$	94	120		*	*		dB
FREQUENCY RESPONSE Unity Gain, Small Signal Full Power Response Slew Rate Settling Time: 0.1% 0.01% Overload Recovery, 50% Overdrive ⁽²⁾	$20V_{p-p}$, $R_L = 2k\Omega$ $V_O = \pm 10V$, $R_L = 2k\Omega$ $G = -1$, $R_L = 2k\Omega$, $10V$ Step $G = -1$	1	1 47 2.5 5 10 5		*	*		MHz kHz V/ μs μs μs μs
RATED OUTPUT Voltage Output Current Output Load Capacitance Stability Short-Circuit Current	$R_L = 2k\Omega$ $V_O = \pm 12V$ Gain = +1	± 12 ± 6	± 13 ± 10 1000 ± 35	± 55	*	*	*	V mA pF mA
POWER SUPPLY Rated Voltage Voltage Range, Derated Performance Current, Quiescent	$I_O = 0mA$	± 5	± 15 1.2	± 18 1.8	*	*	*	V V mA
TEMPERATURE Specification Operating Storage Thermal Resistance DIP-8 SO-8	Ambient Temperature Ambient Temperature θ_{JA} , Junction-to-Ambient	-40 -40 -40		+85 +125 +125	*	*	*	$^\circ C$ $^\circ C$ $^\circ C$ $^\circ C/W$ $^\circ C/W$

NOTES: (1) High-speed automated test.

(2) Overload recovery is defined as the time required for the output to return from saturation to linear operation following the removal of a 50% input overdrive.

ABSOLUTE MAXIMUM RATINGS

Power Supply Voltage	±18V
Differential Input Voltage	V ₋ to V ₊
Input Voltage Range	V ₋ to V ₊
Storage Temperature Range	-40°C to +125°C
Operating Temperature Range	-40°C to +125°C
Output Short Circuit Duration ⁽¹⁾	Continuous
Junction Temperature (T _j)	+150°C

NOTE: (1) Short circuit may be to power supply common at +25°C ambient.



ELECTROSTATIC DISCHARGE SENSITIVITY

Any integrated circuit can be damaged by ESD. Texas Instruments recommends that all integrated circuits be handled with appropriate precautions. Failure to observe proper handling and installation procedures can cause damage.

ESD damage can range from subtle performance degradation to complete device failure. Precision integrated circuits may be more susceptible to damage because very small parametric changes could cause the device not to meet published specifications.

PACKAGE INFORMATION⁽¹⁾

PRODUCT	PACKAGE-LEAD	PACKAGE DESIGNATOR
OPA129P	DIP-8	P
OPA129PB	DIP-8	P
OPA129U	SO-8	D
OPA129UB	SO-8	D

NOTE: (1) For the most current package and ordering information, see the Package Option Addendum at the end of this data sheet, or see the TI website at www.ti.com.

CONNECTION DIAGRAM

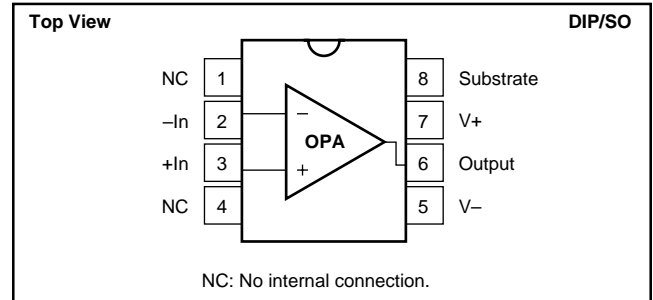

TYPICAL PERFORMANCE CURVES

At T_a = +25°C, +15VDC, unless otherwise noted.

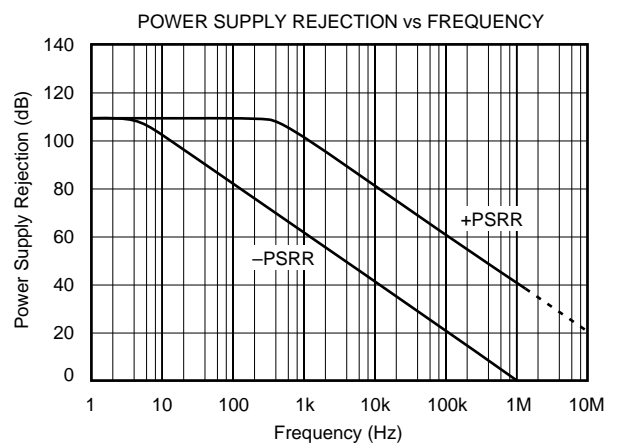
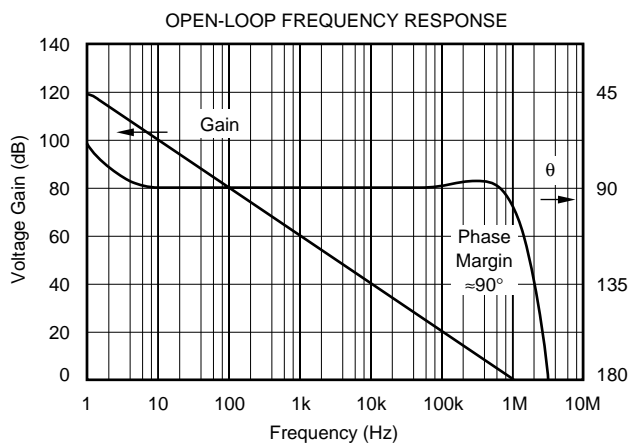

TYPICAL PERFORMANCE CURVES (Cont.)

At $T_A = +25^\circ\text{C}$, $+15\text{VDC}$, unless otherwise noted.

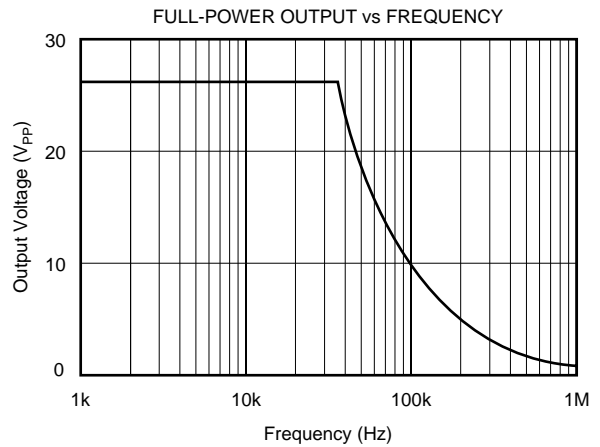
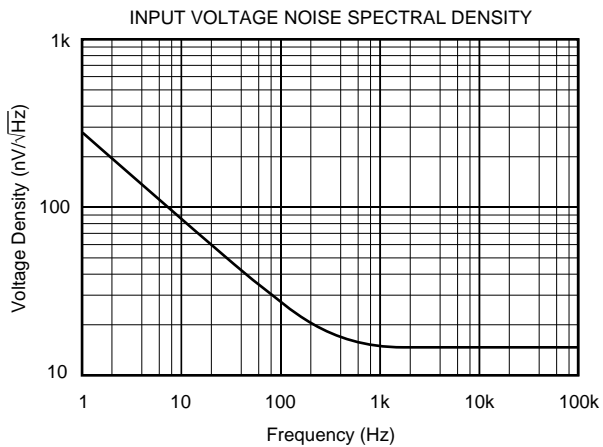
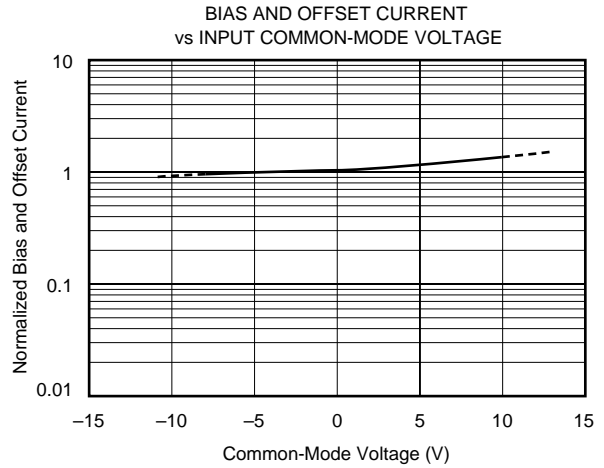
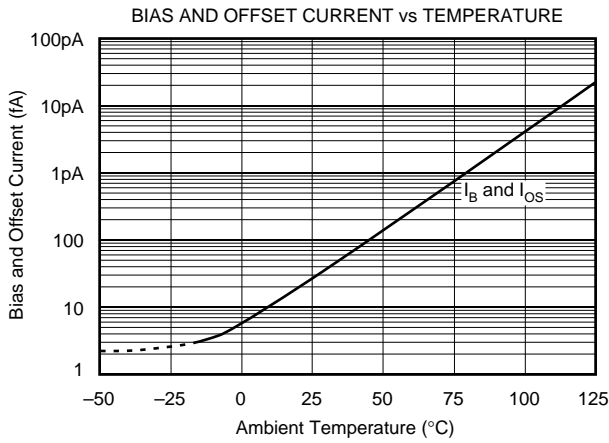
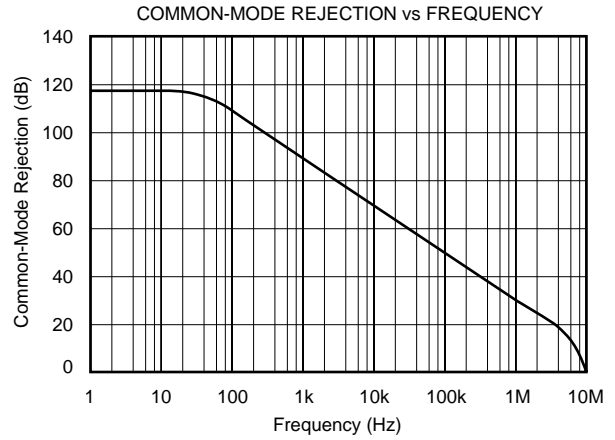
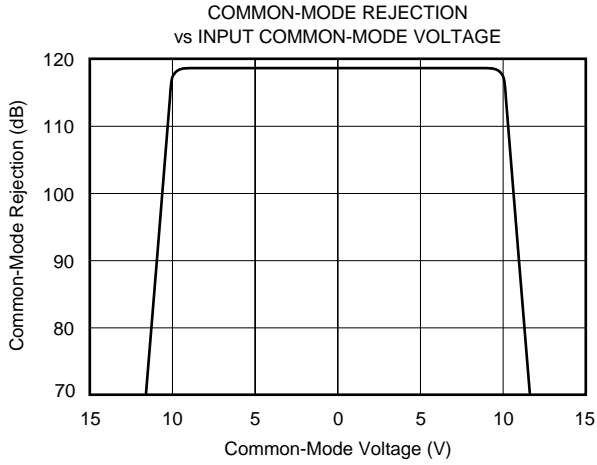

TYPICAL PERFORMANCE CURVES (Cont.)

At $T_A = +25^\circ\text{C}$, $+15\text{VDC}$, unless otherwise noted.

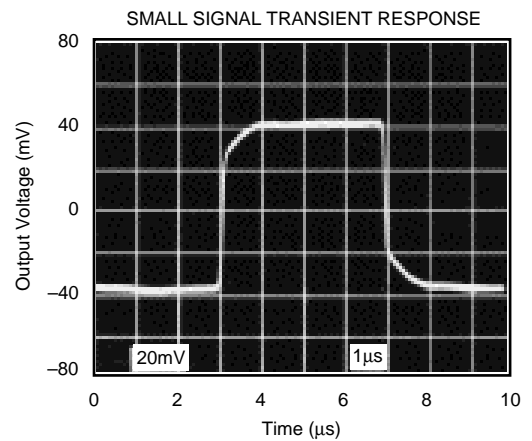
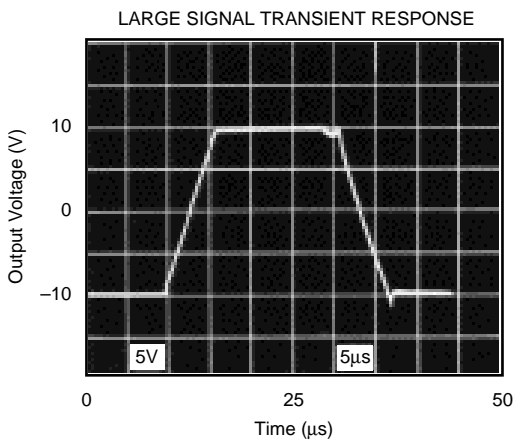
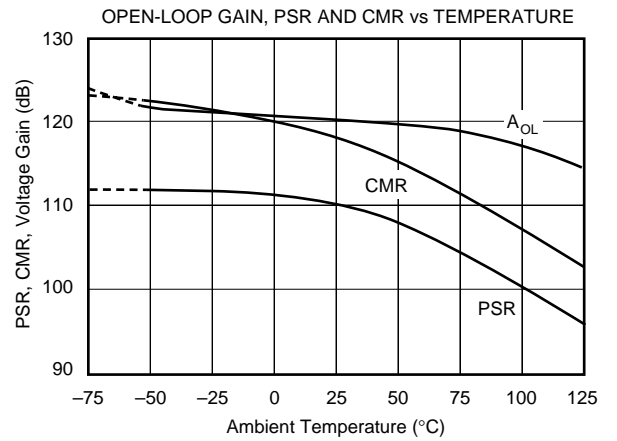
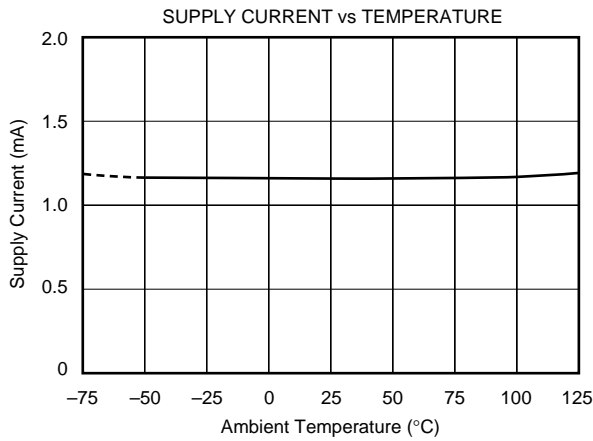
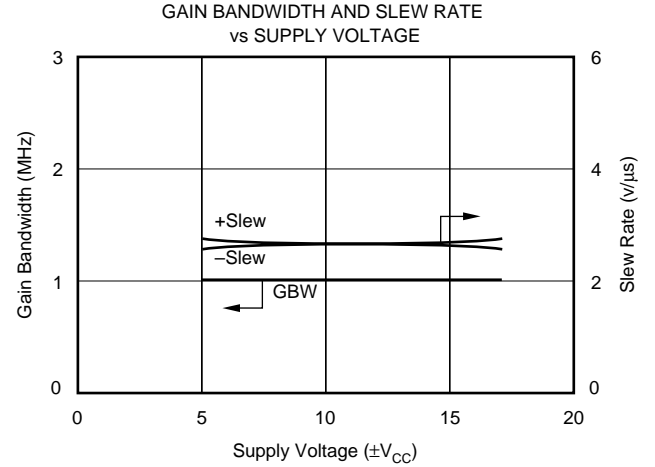
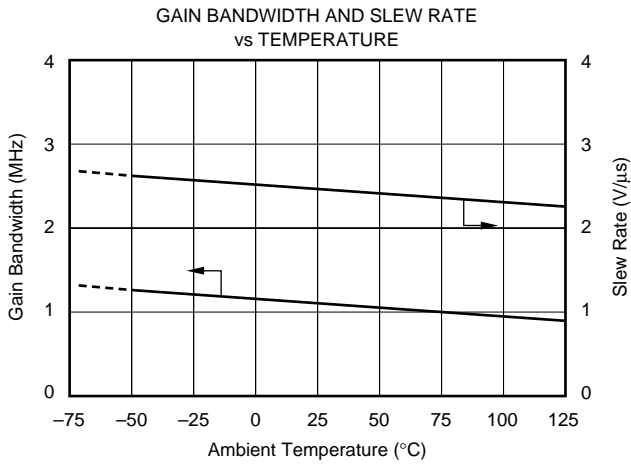

TYPICAL PERFORMANCE CURVES (CONT)

$T_A = +25^\circ\text{C}$, +15VDC, unless otherwise noted.

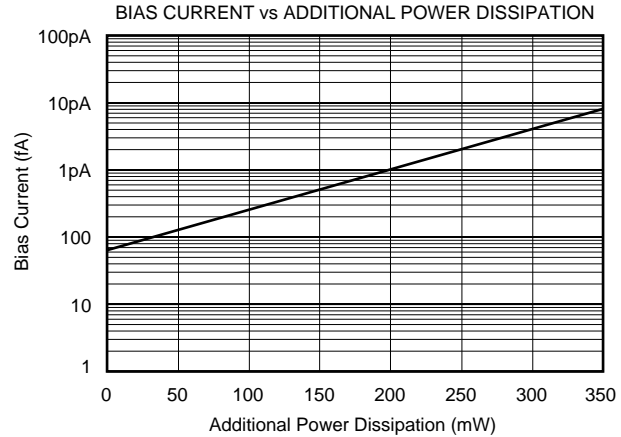
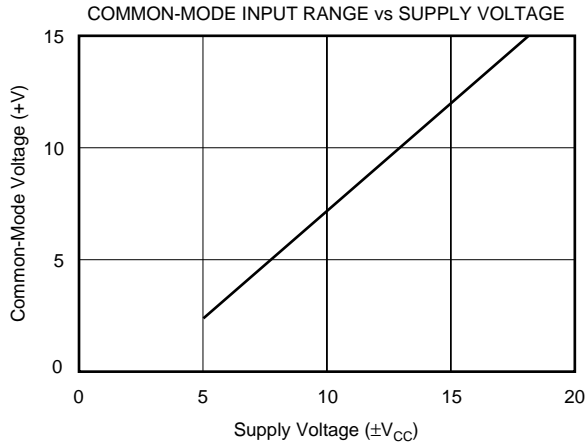

APPLICATIONS INFORMATION

NON-STANDARD PINOUT

The OPA129 uses a non-standard pinout to achieve lowest possible input bias current. The negative power supply is connected to pin 5—see Figure 1. This is done to reduce the leakage current from the V- supply (pin 4 on conventional op amps) to the op amp input terminals. With this new pinout, sensitive inputs are separated from both power supply pins.

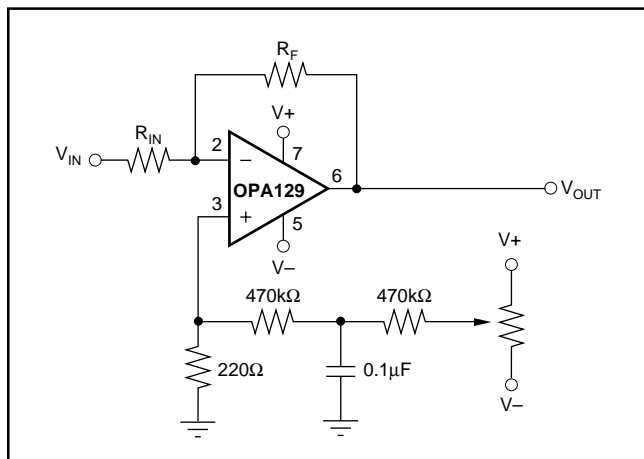

FIGURE 1. Offset Adjust Circuit.

OFFSET VOLTAGE TRIM

The OPA129 has no conventional offset trim connections. Pin 1, next to the critical inverting input, has no internal connection. This eliminates a source of leakage current and allows guarding of the input terminals. Pin 1 and pin 4, next to the two input pins, have no internal connection. This allows an optimized circuit board layout with guarding—see the *Circuit Board Layout* section.

Due to its laser-trimmed input stage, most applications do not require external offset voltage trimming. If trimming is required, the circuit shown in Figure 1 can be used. Power supply voltages are divided down, filtered and applied to the non-inverting input. The circuit shown is sensitive to variation in the supply voltages. Regulation can be added, if needed.

GUARDING AND SHIELDING

Ultra-low input bias current op amps require precautions to achieve best performance. Leakage current on the surface of circuit board can exceed the input bias current of the amplifier. For example, a circuit board resistance of $10^{12}\Omega$ from a power supply pin to an input pin produces a current of 15pA—more than 100 times the input bias current of the op amp.

To minimize surface leakage, a guard trace should completely surround the input terminals and other circuitry connecting to the inputs of the op amp. The DIP package should have a guard trace on both sides of the circuit board. The guard ring should be driven by a circuit node equal in potential to the op amp inputs—see Figure 2. The substrate, pin 8, should also be connected to the circuit board guard to assure that the amplifier is fully surrounded by the guard potential. This minimizes leakage current and noise pick-up.

Careful shielding is required to reduce noise pickup. Shielding near feedback components may also help reduce noise pick-up.

Triboelectric effects (friction-generated charge) can be a troublesome source of errors. Vibration of the circuit board, input connectors and input cables can cause noise and drift. Make the assembly as rigid as possible. Attach cables to avoid motion and vibration. Special low noise or low leakage cables may help reduce noise and leakage current. Keep all input connections as short possible. Surface-mount components may reduce circuit board size and allow a more rigid assembly.

CIRCUIT BOARD LAYOUT

The OPA129 uses a new pinout for ultra low input bias current. Pin 1 and pin 4 have no internal connection. This allows ample circuit board space for a guard ring surrounding the op amp input pins—even with the tiny SO-8 surface-mount package. Figure 3 shows suggested circuit board layouts. The guard ring should be connected to pin 8 (substrate) as shown. It should be driven by a circuit node equal in potential to the input terminals of the op amp—see Figure 2 for common circuit configurations.

TESTING

Accurately testing the OPA129 is extremely difficult due to its high performance. Ordinary test equipment may not be able to resolve the amplifier's extremely low bias current. Inaccurate bias current measurements can be due to:

1. Test socket leakage.
2. Unclean package.
3. Humidity or dew point condensations.
4. Circuit contamination from fingerprints or anti-static treatment chemicals.
5. Test ambient temperature.
6. Load power dissipation.
7. Mechanical stress.
8. Electrostatic and electromagnetic interference.

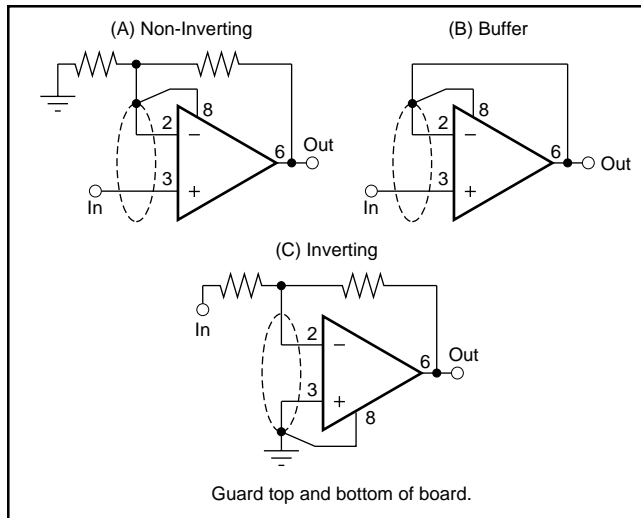

FIGURE 2. Connection of Input Guard.

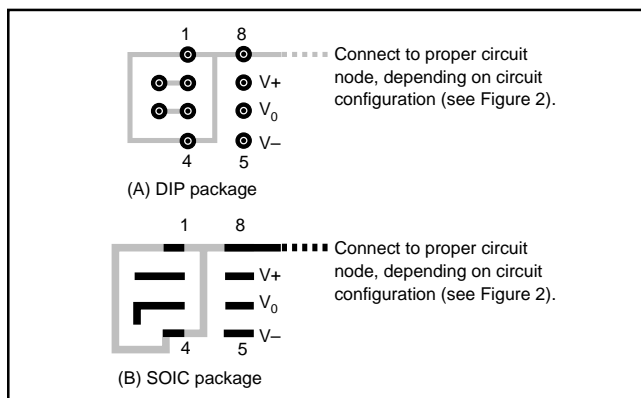

FIGURE 3. Suggested Board Layout for Input Guard.

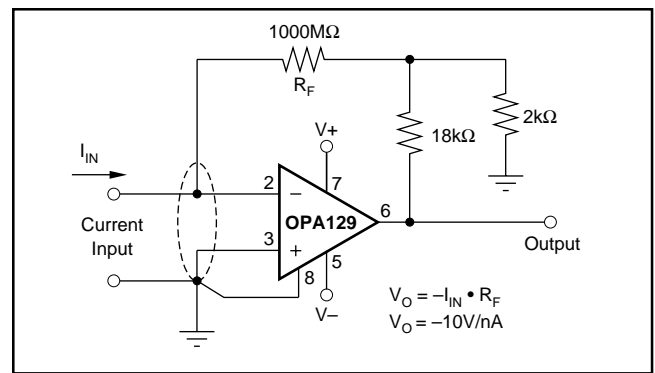

FIGURE 4. Current-to-Voltage Converter.

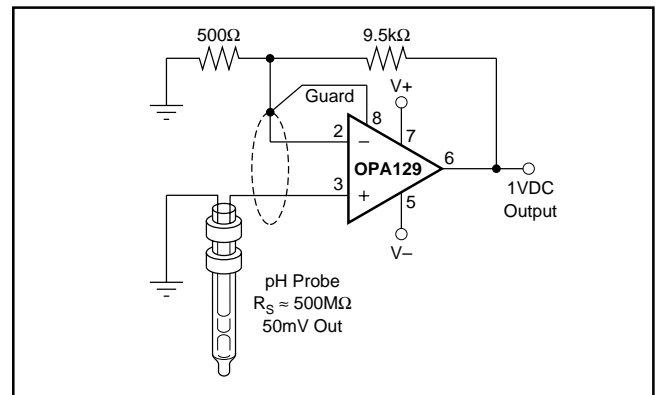

FIGURE 5. High Impedance ($10^{15}\Omega$) Amplifier.

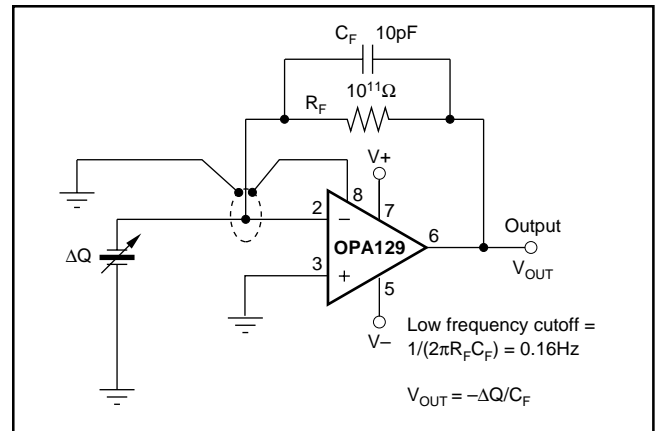

FIGURE 6. Piezoelectric Transducer Charge Amplifier.

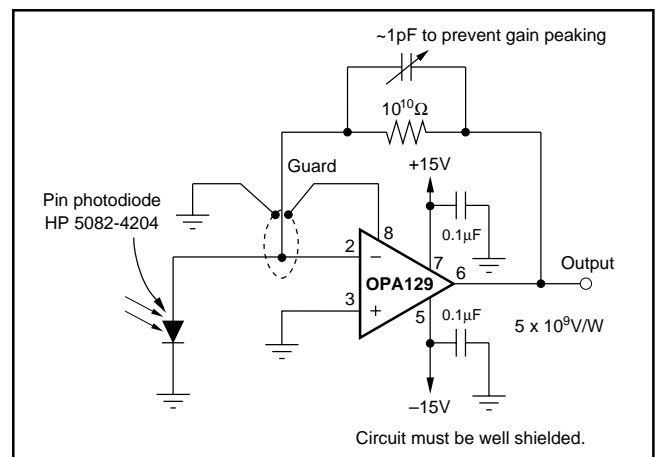

FIGURE 7. Sensitive Photodiode Amplifier.

PACKAGING INFORMATION

Orderable Device	Status (1)	Package Type	Package Drawing	Pins	Package Qty	Eco Plan (2)	Lead/Ball Finish (6)	MSL Peak Temp (3)	Op Temp (°C)	Device Marking (4/5)	Samples
OPA129U	LIFEBUY	SOIC	D	8	75	Green (RoHS & no Sb/Br)	CU NIPDAU	Level-3-260C-168 HR	-40 to 125	OPA 129U	
OPA129UB	LIFEBUY	SOIC	D	8	75	Green (RoHS & no Sb/Br)	CU NIPDAU	Level-3-260C-168 HR	-40 to 125	OPA 129U B	
OPA129UB/2K5	LIFEBUY	SOIC	D	8	2500	Green (RoHS & no Sb/Br)	CU NIPDAU	Level-3-260C-168 HR	-40 to 125	OPA 129U B	
OPA129UBE4	LIFEBUY	SOIC	D	8	75	Green (RoHS & no Sb/Br)	CU NIPDAU	Level-3-260C-168 HR	-40 to 125	OPA 129U B	

(1) The marketing status values are defined as follows:

ACTIVE: Product device recommended for new designs.

LIFEBUY: TI has announced that the device will be discontinued, and a lifetime-buy period is in effect.

NRND: Not recommended for new designs. Device is in production to support existing customers, but TI does not recommend using this part in a new design.

PREVIEW: Device has been announced but is not in production. Samples may or may not be available.

OBSELETE: TI has discontinued the production of the device.

(2) **RoHS:** TI defines "RoHS" to mean semiconductor products that are compliant with the current EU RoHS requirements for all 10 RoHS substances, including the requirement that RoHS substance do not exceed 0.1% by weight in homogeneous materials. Where designed to be soldered at high temperatures, "RoHS" products are suitable for use in specified lead-free processes. TI may reference these types of products as "Pb-Free".

RoHS Exempt: TI defines "RoHS Exempt" to mean products that contain lead but are compliant with EU RoHS pursuant to a specific EU RoHS exemption.

Green: TI defines "Green" to mean the content of Chlorine (Cl) and Bromine (Br) based flame retardants meet JS709B low halogen requirements of <=1000ppm threshold. Antimony trioxide based flame retardants must also meet the <=1000ppm threshold requirement.

(3) MSL, Peak Temp. - The Moisture Sensitivity Level rating according to the JEDEC industry standard classifications, and peak solder temperature.

(4) There may be additional marking, which relates to the logo, the lot trace code information, or the environmental category on the device.

(5) Multiple Device Markings will be inside parentheses. Only one Device Marking contained in parentheses and separated by a "-" will appear on a device. If a line is indented then it is a continuation of the previous line and the two combined represent the entire Device Marking for that device.

(6) Lead/Ball Finish - Orderable Devices may have multiple material finish options. Finish options are separated by a vertical ruled line. Lead/Ball Finish values may wrap to two lines if the finish value exceeds the maximum column width.

Important Information and Disclaimer: The information provided on this page represents TI's knowledge and belief as of the date that it is provided. TI bases its knowledge and belief on information provided by third parties, and makes no representation or warranty as to the accuracy of such information. Efforts are underway to better integrate information from third parties. TI has taken and continues to take reasonable steps to provide representative and accurate information but may not have conducted destructive testing or chemical analysis on incoming materials and chemicals. TI and TI suppliers consider certain information to be proprietary, and thus CAS numbers and other limited information may not be available for release.

In no event shall TI's liability arising out of such information exceed the total purchase price of the TI part(s) at issue in this document sold by TI to Customer on an annual basis.

TAPE AND REEL INFORMATION

REEL DIMENSIONS



TAPE DIMENSIONS



A0	Dimension designed to accommodate the component width
B0	Dimension designed to accommodate the component length
K0	Dimension designed to accommodate the component thickness
W	Overall width of the carrier tape
P1	Pitch between successive cavity centers

TAPE AND REEL INFORMATION

*All dimensions are nominal

Device	Package Type	Package Drawing	Pins	SPQ	Reel Diameter (mm)	Reel Width W1 (mm)	A0 (mm)	B0 (mm)	K0 (mm)	P1 (mm)	W (mm)	Pin1 Quadrant
OPA129UB/2K5	SOIC	D	8	2500	330.0	12.4	6.4	5.2	2.1	8.0	12.0	Q1

TAPE AND REEL BOX DIMENSIONS



*All dimensions are nominal

Device	Package Type	Package Drawing	Pins	SPQ	Length (mm)	Width (mm)	Height (mm)
OPA129UB/2K5	SOIC	D	8	2500	367.0	367.0	35.0



D0008A

PACKAGE OUTLINE

SOIC - 1.75 mm max height

SMALL OUTLINE INTEGRATED CIRCUIT

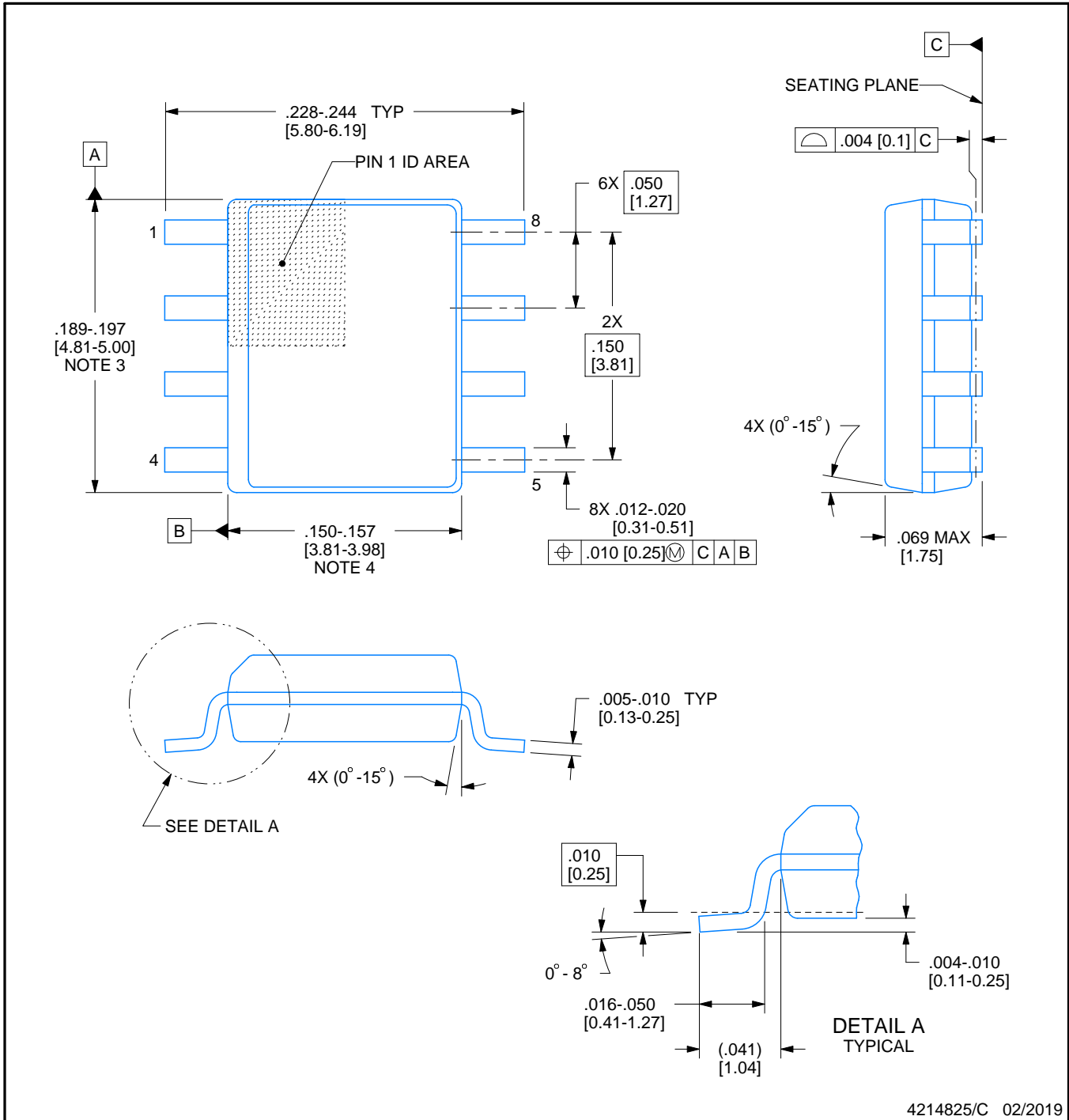

4214825/C 02/2019

NOTES:

- Linear dimensions are in inches [millimeters]. Dimensions in parenthesis are for reference only. Controlling dimensions are in inches. Dimensioning and tolerancing per ASME Y14.5M.
- This drawing is subject to change without notice.
- This dimension does not include mold flash, protrusions, or gate burrs. Mold flash, protrusions, or gate burrs shall not exceed .006 [0.15] per side.
- This dimension does not include interlead flash.
- Reference JEDEC registration MS-012, variation AA.

EXAMPLE BOARD LAYOUT

D0008A

SOIC - 1.75 mm max height

SMALL OUTLINE INTEGRATED CIRCUIT



LAND PATTERN EXAMPLE
 EXPOSED METAL SHOWN
 SCALE:8X



SOLDER MASK DETAILS

4214825/C 02/2019

NOTES: (continued)

- 6. Publication IPC-7351 may have alternate designs.
- 7. Solder mask tolerances between and around signal pads can vary based on board fabrication site.

EXAMPLE STENCIL DESIGN

D0008A

SOIC - 1.75 mm max height

SMALL OUTLINE INTEGRATED CIRCUIT



SOLDER PASTE EXAMPLE
BASED ON .005 INCH [0.125 MM] THICK STENCIL
SCALE:8X

4214825/C 02/2019

NOTES: (continued)

8. Laser cutting apertures with trapezoidal walls and rounded corners may offer better paste release. IPC-7525 may have alternate design recommendations.
9. Board assembly site may have different recommendations for stencil design.

IMPORTANT NOTICE AND DISCLAIMER

TI PROVIDES TECHNICAL AND RELIABILITY DATA (INCLUDING DATASHEETS), DESIGN RESOURCES (INCLUDING REFERENCE DESIGNS), APPLICATION OR OTHER DESIGN ADVICE, WEB TOOLS, SAFETY INFORMATION, AND OTHER RESOURCES "AS IS" AND WITH ALL FAULTS, AND DISCLAIMS ALL WARRANTIES, EXPRESS AND IMPLIED, INCLUDING WITHOUT LIMITATION ANY IMPLIED WARRANTIES OF MERCHANTABILITY, FITNESS FOR A PARTICULAR PURPOSE OR NON-INFRINGEMENT OF THIRD PARTY INTELLECTUAL PROPERTY RIGHTS.

These resources are intended for skilled developers designing with TI products. You are solely responsible for (1) selecting the appropriate TI products for your application, (2) designing, validating and testing your application, and (3) ensuring your application meets applicable standards, and any other safety, security, or other requirements. These resources are subject to change without notice. TI grants you permission to use these resources only for development of an application that uses the TI products described in the resource. Other reproduction and display of these resources is prohibited. No license is granted to any other TI intellectual property right or to any third party intellectual property right. TI disclaims responsibility for, and you will fully indemnify TI and its representatives against, any claims, damages, costs, losses, and liabilities arising out of your use of these resources.

TI's products are provided subject to TI's Terms of Sale (www.ti.com/legal/termsofsale.html) or other applicable terms available either on ti.com or provided in conjunction with such TI products. TI's provision of these resources does not expand or otherwise alter TI's applicable warranties or warranty disclaimers for TI products.

Mailing Address: Texas Instruments, Post Office Box 655303, Dallas, Texas 75265
Copyright © 2019, Texas Instruments Incorporated

Looking for pricing, stock, or lifecycle information?

Click below to explore more details on WIN SOURCE:

 [View OPA129UB/2K5E4 on WIN SOURCE](#)

 [Texas Instruments](#) Information

Optimize Your Supply Chain with WIN SOURCE Solutions

-  Global Sourcing Solution
-  Obsolete Management
-  Cost Control Management
-  Shortage Management
-  Alternative Solution
-  Excess Inventory Management