



THE DATASHEET OF OPA1611AIDR



OPA161x SoundPlus™ High-Performance, Bipolar-Input Audio Operational Amplifiers

1 Features

- Superior Sound Quality
- Ultralow Noise: 1.1 nV/ $\sqrt{\text{Hz}}$ at 1 kHz
- Ultralow Distortion: 0.000015% at 1 kHz
- High Slew Rate: 27 V/ μs
- Wide Bandwidth: 40 MHz (G = +1)
- High Open-Loop Gain: 130 dB
- Unity Gain Stable
- Low Quiescent Current: 3.6 mA per Channel
- Rail-to-Rail Output
- Wide Supply Range: ± 2.25 V to ± 18 V
- Single and Dual Versions Available

2 Applications

- Professional Audio Equipment
- Microphone Preamplifiers
- Analog and Digital Mixing Consoles
- Broadcast Studio Equipment
- Audio Test And Measurement
- High-End A/V Receivers

3 Description

The OPA1611 (single) and OPA1612 (dual) bipolar-input operational amplifiers achieve very low 1.1-nV/ $\sqrt{\text{Hz}}$ noise density with an ultralow distortion of 0.000015% at 1 kHz. The OPA1611 and OPA1612 offer rail-to-rail output swing to within 600 mV with a 2-k Ω load, which increases headroom and maximizes dynamic range. These devices also have a high output drive capability of ± 30 mA.

These devices operate over a very wide supply range of ± 2.25 V to ± 18 V, on only 3.6 mA of supply current per channel. The OPA1611 and OPA1612 op amps are unity-gain stable and provide excellent dynamic behavior over a wide range of load conditions.

The dual version features completely independent circuitry for lowest crosstalk and freedom from interactions between channels, even when overdriven or overloaded.

Both the OPA1611 and OPA1612 are available in SOIC-8 packages and the OPA1612 is available in SON-8. These devices are specified from -40°C to $+85^\circ\text{C}$.

Device Information⁽¹⁾

PART NUMBER	PACKAGE	BODY SIZE (NOM)
OPA1611	SOIC (8)	4.90 mm x 3.91 mm
OPA1612	SOIC (8)	4.90 mm x 3.91 mm
	SON (8)	3.00 mm x 3.00 mm

(1) For all available packages, see the orderable addendum at the end of the datasheet.

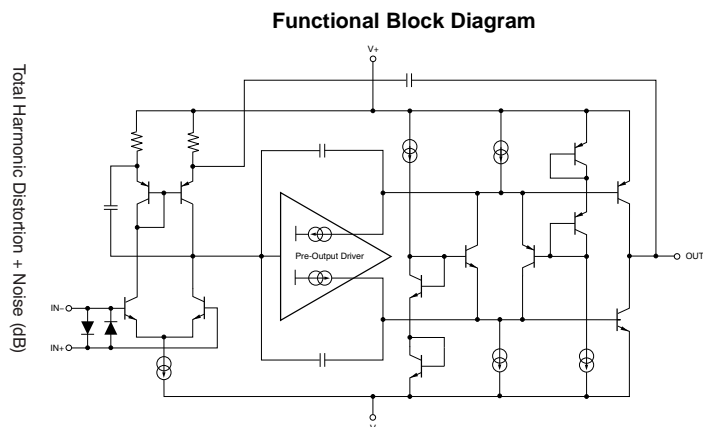
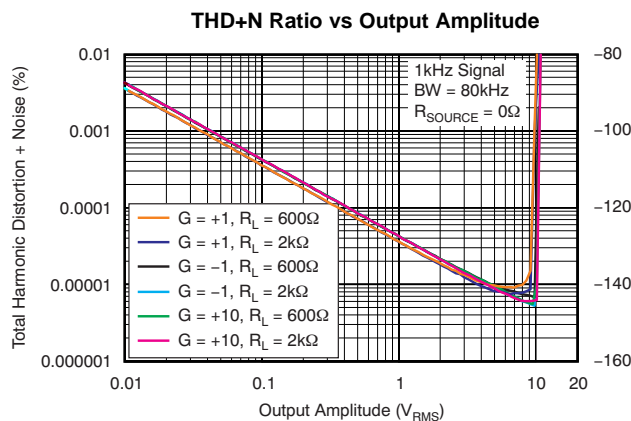

Table of Contents

1 Features	1	8.1 Application Information.....	15
2 Applications	1	8.2 Noise Performance	15
3 Description	1	8.3 Total Harmonic Distortion Measurements.....	17
4 Revision History	2	8.4 Capacitive Loads.....	17
5 Pin Configuration and Functions	3	8.5 Application Circuit	18
6 Specifications	4	9 Power-Supply Recommendations	19
6.1 Absolute Maximum Ratings	4	10 Layout	20
6.2 Handling Ratings.....	4	10.1 Layout Guidelines	20
6.3 Recommended Operating Conditions.....	4	10.2 Layout Example	20
6.4 Electrical Characteristics: $V_S = \pm 2.25\text{ V}$ to $\pm 18\text{ V}$	5	11 Device and Documentation Support	21
6.5 Typical Characteristics.....	7	11.1 Documentation Support	21
7 Detailed Description	12	11.2 Related Links	21
7.1 Overview	12	11.3 Trademarks	21
7.2 Functional Block Diagram	12	11.4 Electrostatic Discharge Caution.....	21
7.3 Feature Description.....	12	11.5 Glossary	21
8 Application and Implementation	15	12 Mechanical, Packaging, and Orderable Information	21

4 Revision History

Changes from Revision B (July 2011) to Revision C

Page

• Changed format to meet latest data sheet standards; added new sections, and moved existing sections.....	1
• Added SON-8 (DRG) package to data sheet	1
• Changed SO to SOIC throughout document to match industry standard term	1
• Added front-page curve	1
• Added title to block diagram	1
• Deleted Package Information table; see package option addendum.....	3

Changes from Revision A (August 2009) to Revision B

Page

• Revised <i>Features</i> list items	1
• Updated front-page figure.....	1
• Added max specification for input voltage noise density at $f = 1\text{ kHz}$	5
• Corrected typo in footnote 1 for Electrical Characteristics	5
• Revised Figure 4	7
• Updated Figure 7	7
• Changed Figure 9	7
• Revised Figure 11	7
• Corrected typo in Figure 15	8
• Updated Figure 29	12
• Revised fourth paragraph of <i>Electrical Overstress</i> section	13
• Revised table in Figure 34	17

5 Pin Configuration and Functions

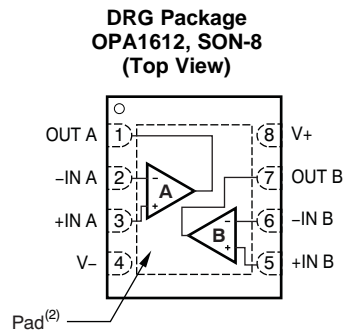
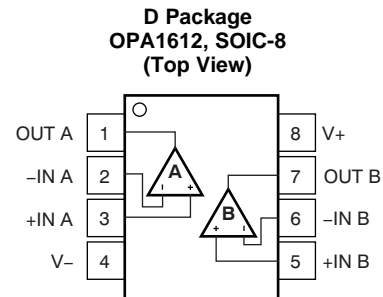
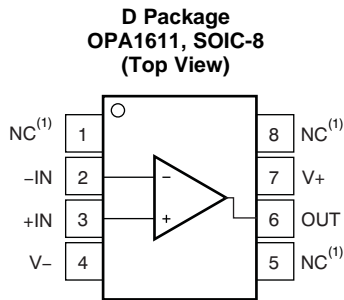

(1) NC denotes no internal connection. Pin can be left floating or connected to any voltage between (V-) and (V+).

(2) Exposed thermal die pad on underside; connect thermal die pad to V-. Soldering the thermal pad improves heat dissipation and provides specified performance.

Pin Functions

NAME	PIN			I/O	DESCRIPTION
	NO.				
	D (OPA1611)	D (OPA1612)	DRG (OPA1612)		
-IN	2	—	—	I	Inverting input
+IN	3	—	—	I	Noninverting input
-IN A	—	2	2	I	Inverting input, channel A
+IN A	—	3	3	I	Noninverting input, channel A
-IN B	—	6	6	I	Inverting input, channel B
+IN B	—	5	5	I	Noninverting input, channel B
NC	1, 5, 8	—	—	—	No internal connection
OUT	6	—	—	O	Output
OUT A	—	1	1	O	Output, channel A
OUT B	—	7	7	O	Output, channel B
V-	4	4	4	—	Negative (lowest) power supply
V+	7	8	8	—	Positive (highest) power supply

6 Specifications

6.1 Absolute Maximum Ratings

over operating free-air temperature range (unless otherwise noted)⁽¹⁾

		MIN	MAX	UNIT
Supply voltage	$V_S = (V+) - (V-)$		40	V
Input voltage		$(V-) - 0.5$	$(V+) + 0.5$	V
Input current (all pins except power-supply pins)			±10	mA
Output short-circuit ⁽²⁾		Continuous		
Operating temperature	(T_A)	-55	+125	°C
Junction temperature	(T_J)		200	°C

- (1) Stresses beyond those listed under *Absolute Maximum Ratings* may cause permanent damage to the device. These are stress ratings only, which do not imply functional operation of the device at these or any other conditions beyond those indicated under *Recommended Operating Conditions*. Exposure to absolute-maximum-rated conditions for extended periods may affect device reliability.
- (2) Short-circuit to $V_S / 2$ (ground in symmetrical dual supply setups), one amplifier per package.

6.2 Handling Ratings

			MIN	MAX	UNIT
T_{stg}	Storage temperature range		-65	+150	°C
$V_{(ESD)}$	Electrostatic discharge	Human body model (HBM), per ANSI/ESDA/JEDEC JS-001, all pins ⁽¹⁾	-3000	3000	V
		Charged device model (CDM), per JEDEC specification JESD22-C101, all pins ⁽²⁾	-1000	1000	
		Machine model (MM)	-200	200	

- (1) JEDEC document JEP155 states that 500-V HBM allows safe manufacturing with a standard ESD control process.
- (2) JEDEC document JEP157 states that 250-V CDM allows safe manufacturing with a standard ESD control process.

6.3 Recommended Operating Conditions

over operating free-air temperature range (unless otherwise noted)

	MIN	NOM	MAX	UNIT
Supply voltage ($V+ - V-$)	4.5 (±2.25)		36 (±18)	V
Specified temperature	-40		+85	°C

6.4 Electrical Characteristics: $V_S = \pm 2.25\text{ V}$ to $\pm 18\text{ V}$

At $T_A = +25^\circ\text{C}$ and $R_L = 2\text{ k}\Omega$, unless otherwise noted. $V_{CM} = V_{OUT} = \text{mid supply}$, unless otherwise noted.

PARAMETER		TEST CONDITIONS	MIN	TYP	MAX	UNIT	
AUDIO PERFORMANCE							
THD+N	Total harmonic distortion + noise	$G = +1$, $f = 1\text{ kHz}$, $V_O = 3 V_{RMS}$	0.000015%				
				-136		dB	
IMD	Intermodulation distortion	SMPTE/DIN two-tone, 4:1 (60 Hz and 7 kHz), $G = +1$, $V_O = 3 V_{RMS}$	0.000015%				
				-136		dB	
		DIM 30 (3-kHz square wave and 15-kHz sine wave), $G = +1$, $V_O = 3 V_{RMS}$	0.000012%				
				-138		dB	
CCIF twin-tone (19 kHz and 20 kHz), $G = +1$, $V_O = 3 V_{RMS}$		0.000008%					
			-142			dB	
FREQUENCY RESPONSE							
GBW	Gain-bandwidth product	$G = 100$		80		MHz	
		$G = 1$		40		MHz	
SR	Slew rate	$G = -1$		27		V/ μs	
		Full-power bandwidth ⁽¹⁾	$V_O = 1 V_{PP}$	4		MHz	
	Overload recovery time	$G = -10$		500		ns	
	Channel separation (dual)	$f = 1\text{ kHz}$		-130		dB	
NOISE							
	Input voltage noise	$f = 20\text{ Hz}$ to 20 kHz		1.2		μV_{PP}	
e_n	Input voltage noise density ⁽²⁾	$f = 10\text{ Hz}$		2		$\text{nV}/\sqrt{\text{Hz}}$	
		$f = 100\text{ Hz}$		1.5		$\text{nV}/\sqrt{\text{Hz}}$	
		$f = 1\text{ kHz}$		1.1	1.5	$\text{nV}/\sqrt{\text{Hz}}$	
i_n	Input current noise density	$f = 10\text{ Hz}$		3		$\text{pA}/\sqrt{\text{Hz}}$	
		$f = 1\text{ kHz}$		1.7		$\text{pA}/\sqrt{\text{Hz}}$	
OFFSET VOLTAGE							
V_{OS}	Input offset voltage	$V_S = \pm 15\text{ V}$		± 100	± 500	μV	
dV_{OS}/dT	V_{OS} over temperature ⁽²⁾	$T_A = -40^\circ\text{C}$ to $+85^\circ\text{C}$		1	4	$\mu\text{V}/^\circ\text{C}$	
PSRR	Power-supply rejection ratio	$V_S = \pm 2.25\text{ V}$ to $\pm 18\text{ V}$		0.1	1	$\mu\text{V}/\text{V}$	
INPUT BIAS CURRENT							
I_B	Input bias current	$V_{CM} = 0\text{ V}$		± 60	± 250	nA	
		$V_{CM} = 0\text{ V}$, DRG package only		± 60	± 300	nA	
	I_B over temperature ⁽²⁾	$T_A = -40^\circ\text{C}$ to $+85^\circ\text{C}$			350	nA	
I_{OS}	Input offset current	$V_{CM} = 0\text{ V}$		± 25	± 175	nA	
INPUT VOLTAGE RANGE							
V_{CM}	Common-mode voltage range		$(V-) + 2$		$(V+) - 2$	V	
CMRR	Common-mode rejection ratio	$(V-) + 2\text{ V} \leq V_{CM} \leq (V+) - 2\text{ V}$	110	120		dB	
INPUT IMPEDANCE							
	Differential			20k 8		Ω pF	
	Common-mode			10^9 2		Ω pF	

(1) Full-power bandwidth = $SR / (2\pi \times V_P)$, where SR = slew rate.

(2) Specified by design and characterization.

Electrical Characteristics: $V_S = \pm 2.25\text{ V}$ to $\pm 18\text{ V}$ (continued)

 At $T_A = +25^\circ\text{C}$ and $R_L = 2\text{ k}\Omega$, unless otherwise noted. $V_{CM} = V_{OUT} = \text{midsupply}$, unless otherwise noted.

PARAMETER		TEST CONDITIONS	MIN	TYP	MAX	UNIT
OPEN-LOOP GAIN						
A_{OL}	Open-loop voltage gain	$(V^-) + 0.2\text{ V} \leq V_O \leq (V^+) - 0.2\text{ V}$, $R_L = 10\text{ k}\Omega$	114	130		dB
		$(V^-) + 0.6\text{ V} \leq V_O \leq (V^+) - 0.6\text{ V}$, $R_L = 2\text{ k}\Omega$	110	114		dB
OUTPUT						
V_{OUT}	Voltage output	$R_L = 10\text{ k}\Omega$, $A_{OL} \geq 114\text{ dB}$	$(V^-) + 0.2$		$(V^+) - 0.2$	V
		$R_L = 2\text{ k}\Omega$, $A_{OL} \geq 110\text{ dB}$	$(V^-) + 0.6$		$(V^+) - 0.6$	V
I_{OUT}	Output current		See Figure 27			mA
Z_O	Open-loop output impedance		See Figure 28			Ω
I_{SC}	Short-circuit current			+55		mA
				-62		mA
C_{LOAD}	Capacitive load drive		See Typical Characteristics			pF
POWER SUPPLY						
V_S	Specified voltage		± 2.25		± 18	V
I_Q	Quiescent current (per channel)	$I_{OUT} = 0\text{ A}$		3.6	4.5	mA
	I_Q over Temperature ⁽³⁾	$T_A = -40^\circ\text{C}$ to $+85^\circ\text{C}$			5.5	mA
TEMPERATURE RANGE						
	Specified range		-40		+85	$^\circ\text{C}$
	Operating range		-55		+125	$^\circ\text{C}$
θ_{JA}	Thermal resistance, SOIC-8			150		$^\circ\text{C/W}$

(3) Specified by design and characterization.

6.5 Typical Characteristics

At $T_A = +25^\circ\text{C}$, $V_S = \pm 15\text{ V}$, and $R_L = 2\text{ k}\Omega$, unless otherwise noted.

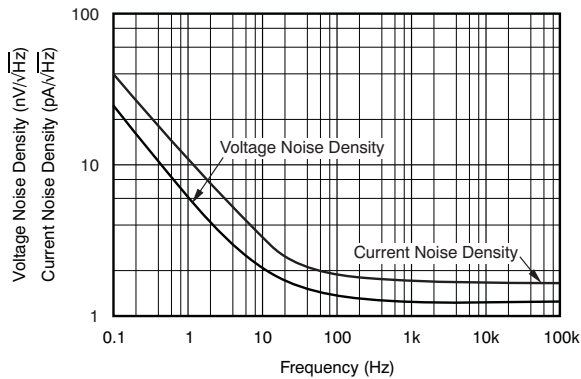

Figure 1. Input Voltage Noise Density and Input Current Noise Density vs Frequency

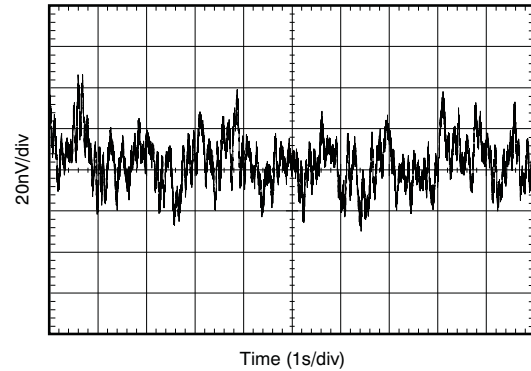

Figure 2. 0.1-Hz to 10-Hz Noise

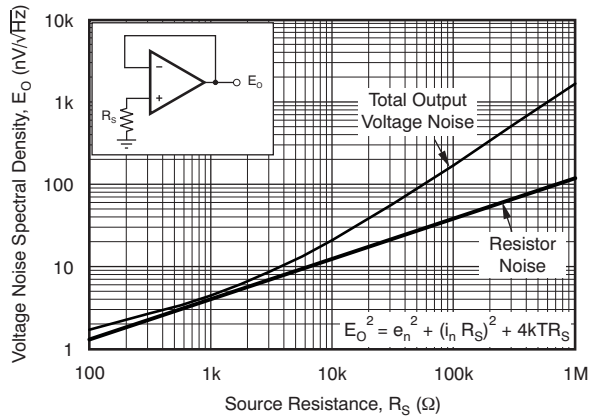

Figure 3. Voltage Noise vs Source Resistance

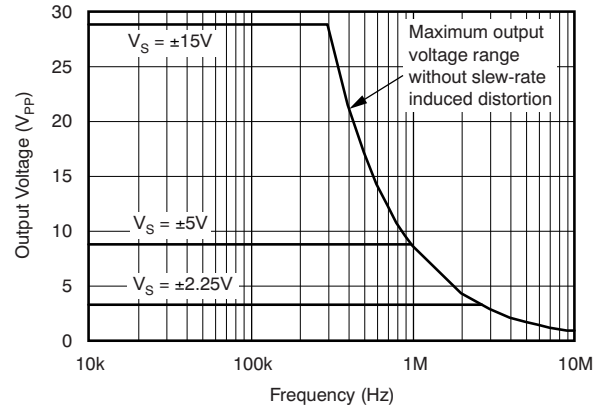

Figure 4. Maximum Output Voltage vs Frequency

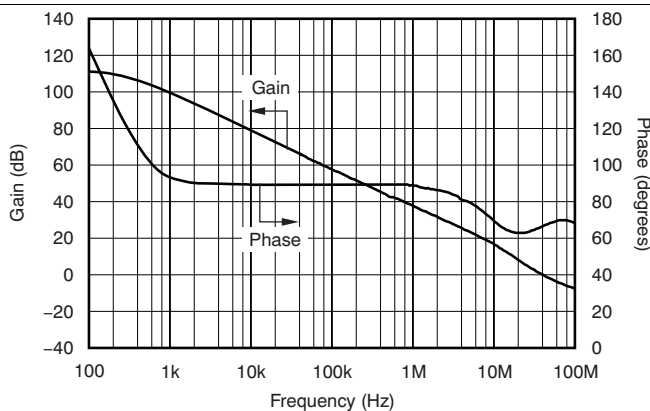

Figure 5. Gain and Phase vs Frequency

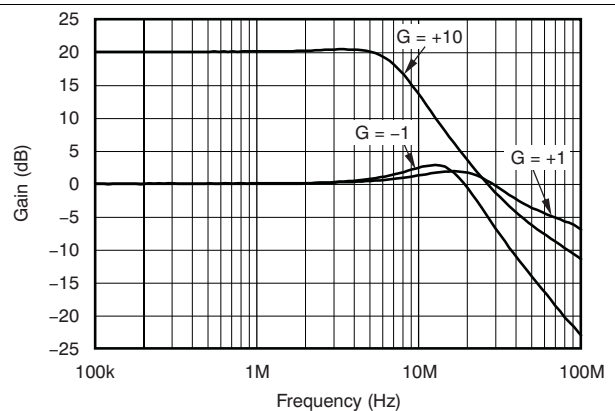

Figure 6. Closed-Loop Gain vs Frequency

Typical Characteristics (continued)

At $T_A = +25^\circ\text{C}$, $V_S = \pm 15\text{ V}$, and $R_L = 2\text{ k}\Omega$, unless otherwise noted.

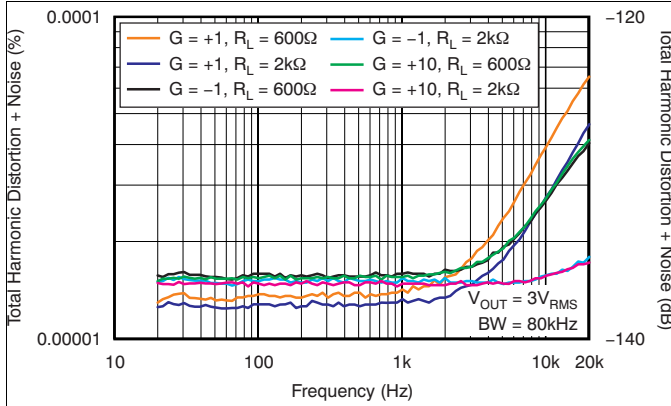

Figure 7. THD+N Ratio vs Frequency

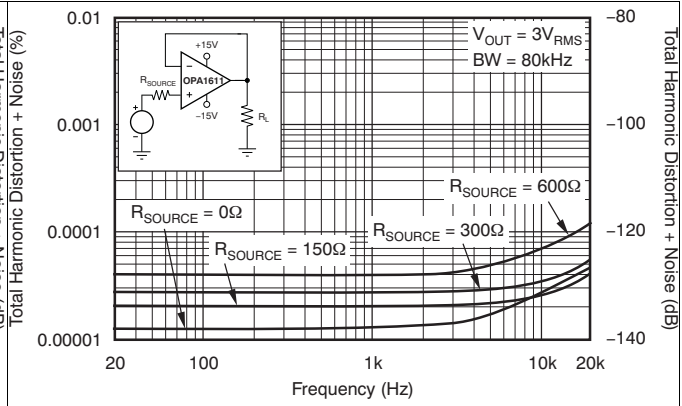

Figure 8. THD+N Ratio vs Frequency

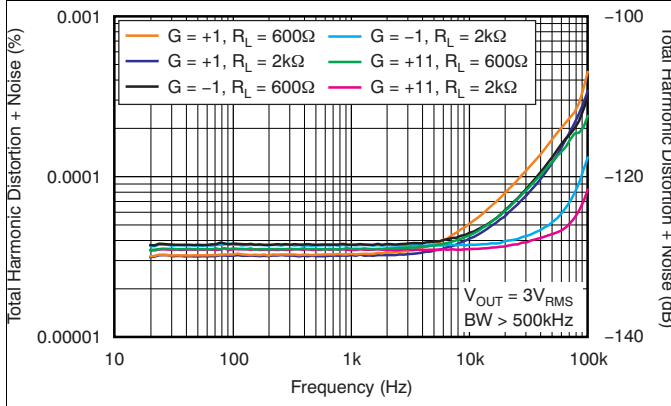

Figure 9. THD+N Ratio vs Frequency

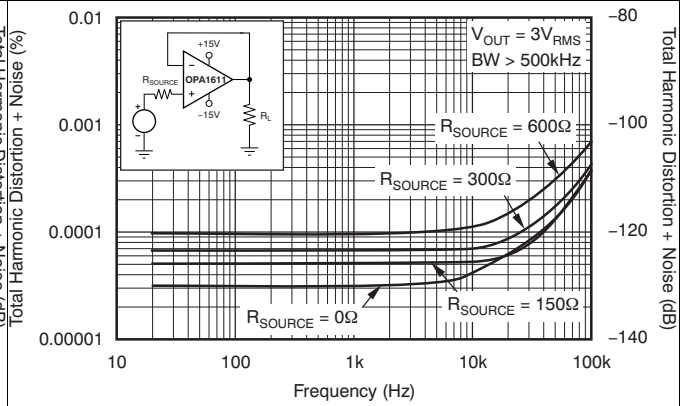

Figure 10. THD+N Ratio vs Frequency

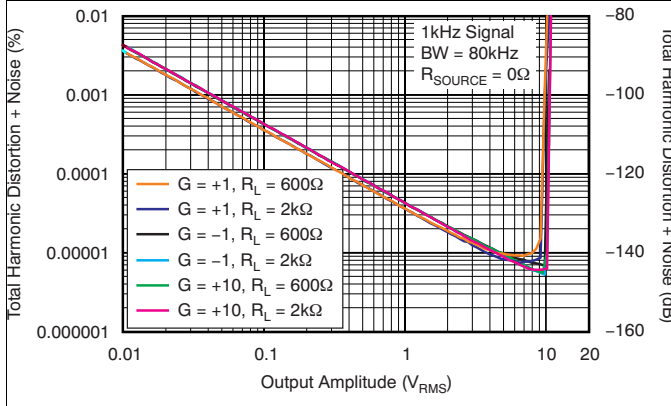

Figure 11. THD+N Ratio vs Output Amplitude

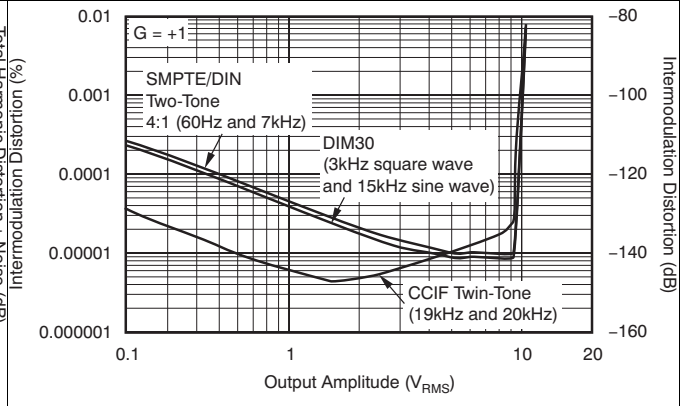

Figure 12. Intermodulation Distortion vs Output Amplitude

Typical Characteristics (continued)

At $T_A = +25^\circ\text{C}$, $V_S = \pm 15\text{ V}$, and $R_L = 2\text{ k}\Omega$, unless otherwise noted.

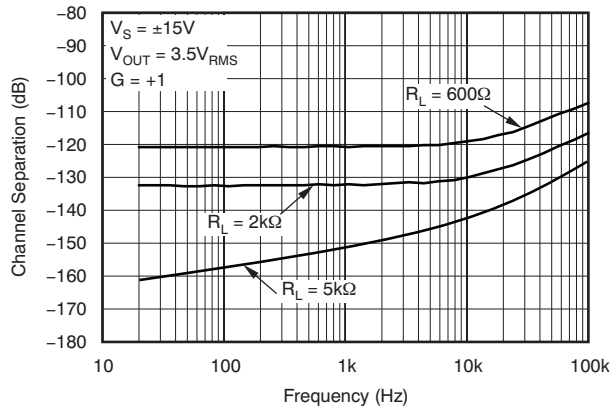

Figure 13. Channel Separation vs Frequency

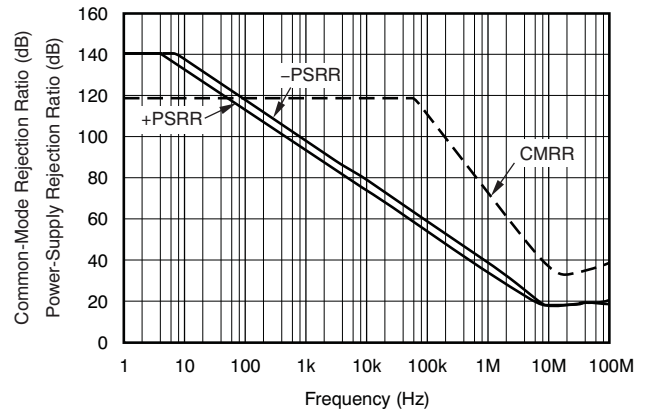

Figure 14. CMRR and PSRR vs Frequency (Referred to Input)

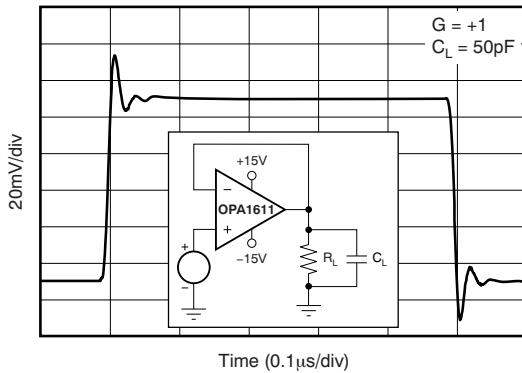

Figure 15. Small-Signal Step Response (100 mV)

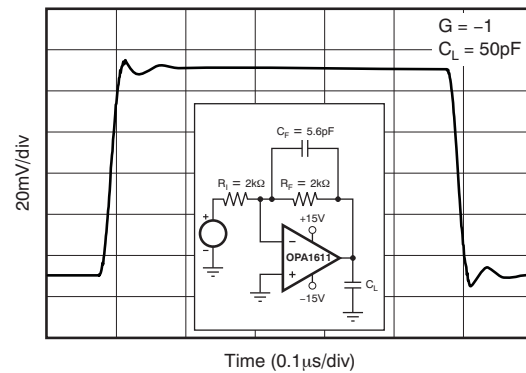

Figure 16. Small-Signal Step Response (100 mV)

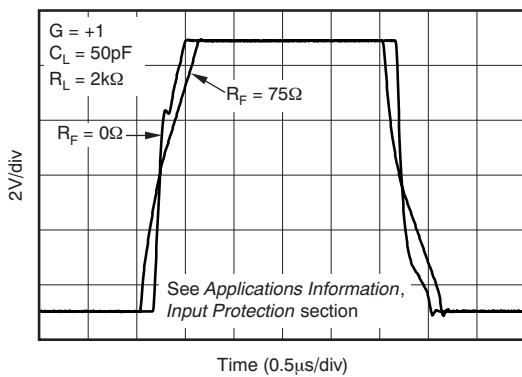

Figure 17. Large-Signal Step Response

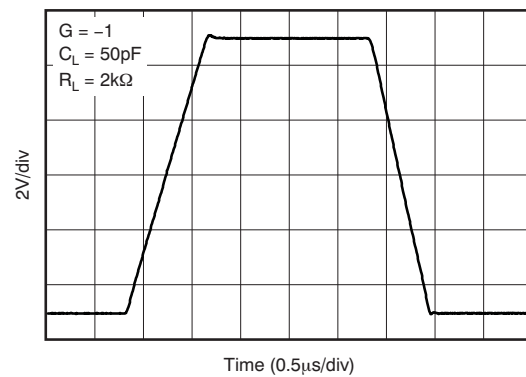

Figure 18. Large-Signal Step Response

Typical Characteristics (continued)

At $T_A = +25^\circ\text{C}$, $V_S = \pm 15\text{ V}$, and $R_L = 2\text{ k}\Omega$, unless otherwise noted.

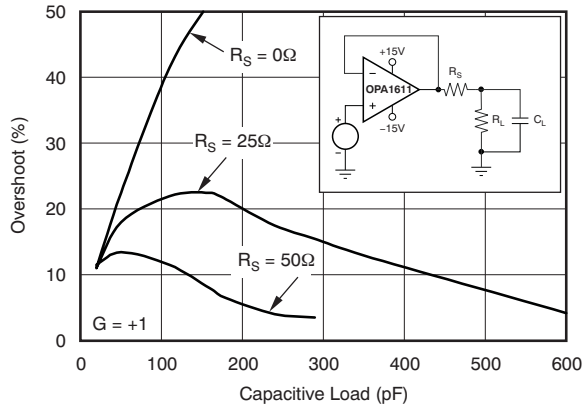

Figure 19. Small-Signal Overshoot vs Capacitive Load (100-mV Output Step)

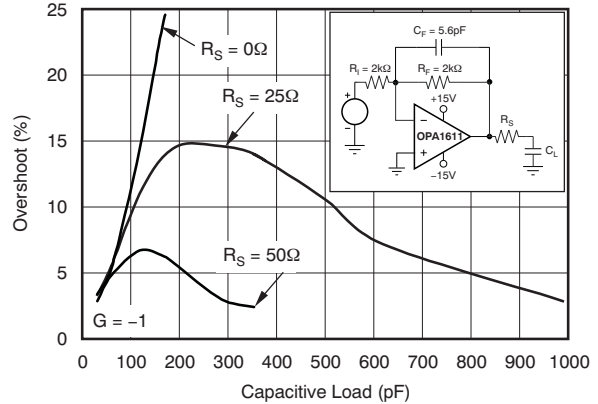

Figure 20. Small-Signal Overshoot vs Capacitive Load (100-mV Output Step)

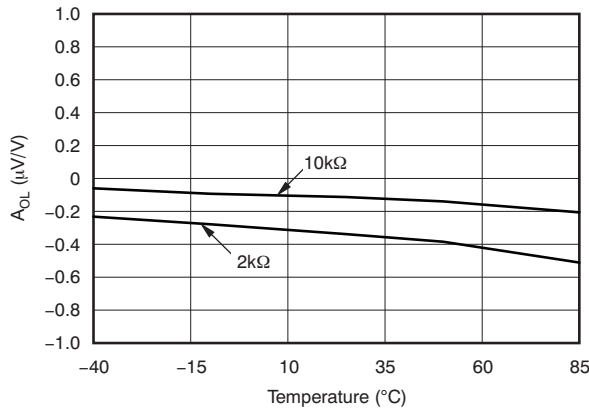

Figure 21. Open-Loop Gain vs Temperature

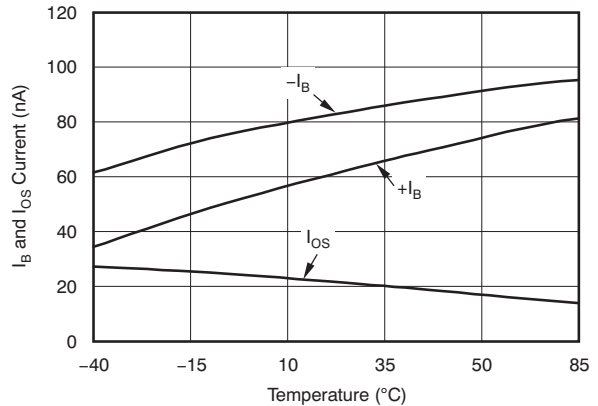

Figure 22. I_B and I_{OS} vs Temperature

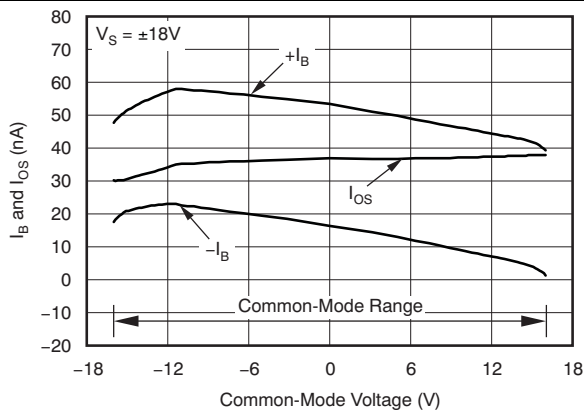

Figure 23. I_B and I_{OS} vs Common-Mode Voltage

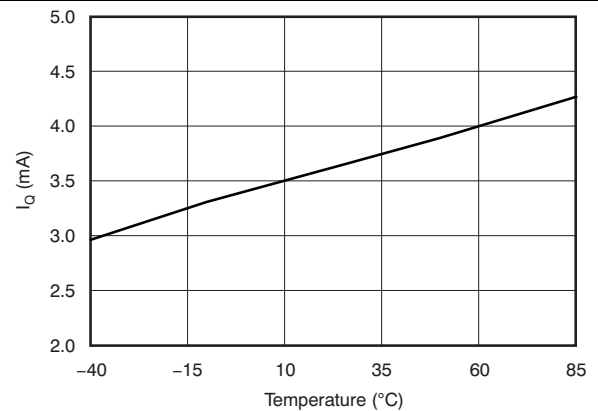

Figure 24. Quiescent Current vs Temperature

Typical Characteristics (continued)

At $T_A = +25^\circ\text{C}$, $V_S = \pm 15\text{ V}$, and $R_L = 2\text{ k}\Omega$, unless otherwise noted.

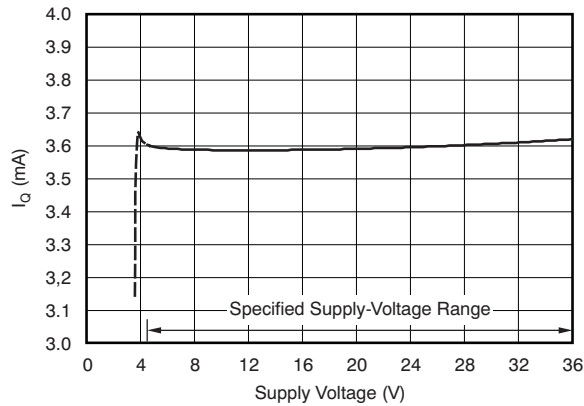

Figure 25. Quiescent Current vs Supply Voltage

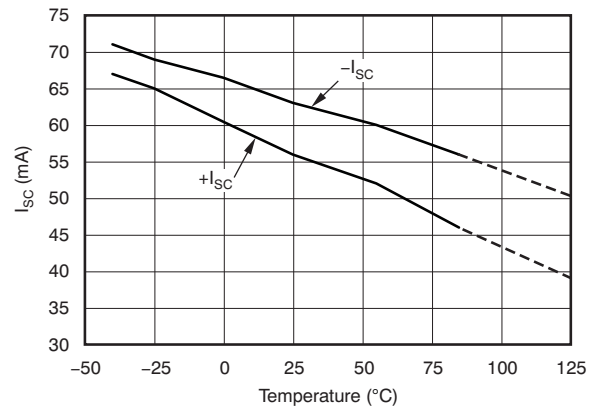

Figure 26. Short-Circuit Current vs Temperature

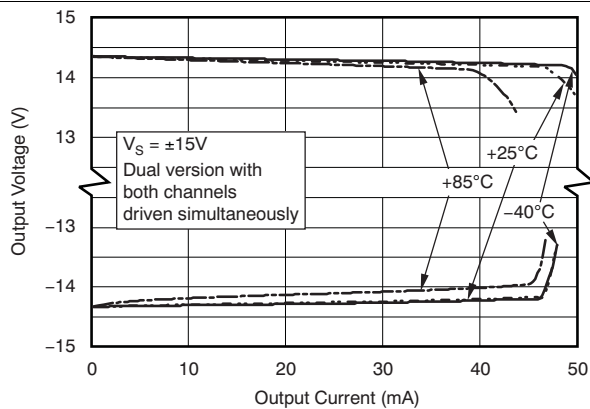

Figure 27. Output Voltage vs Output Current

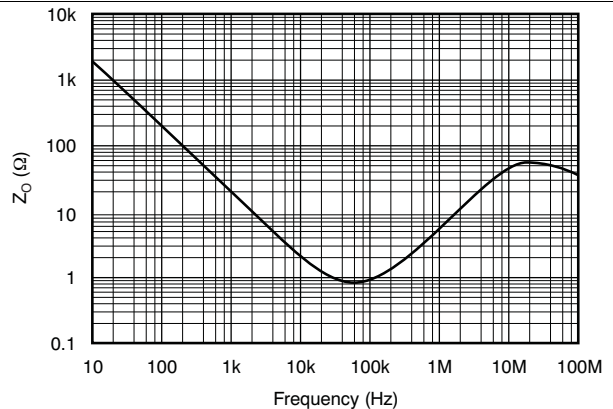

Figure 28. Open-Loop Output Impedance vs Frequency

7 Detailed Description

7.1 Overview

The OPA161x family of bipolar-input operational amplifiers achieve very low $1.1\text{-nV}/\sqrt{\text{Hz}}$ noise density with an ultralow distortion of 0.000015% at 1 kHz. The rail-to-rail output swing, within 600 mV with a 2-k Ω load, increases headroom and maximizes dynamic range. These devices also have a high output drive capability of ± 40 mA. The wide supply range of ± 2.25 V to ± 18 V, on only 3.6 mA of supply current per channel, makes them applicable to both 5V systems and 36V audio applications. The OPA1611 and OPA1612 op amps are unity-gain stable and provide excellent dynamic behavior over a wide range of load conditions.

7.2 Functional Block Diagram

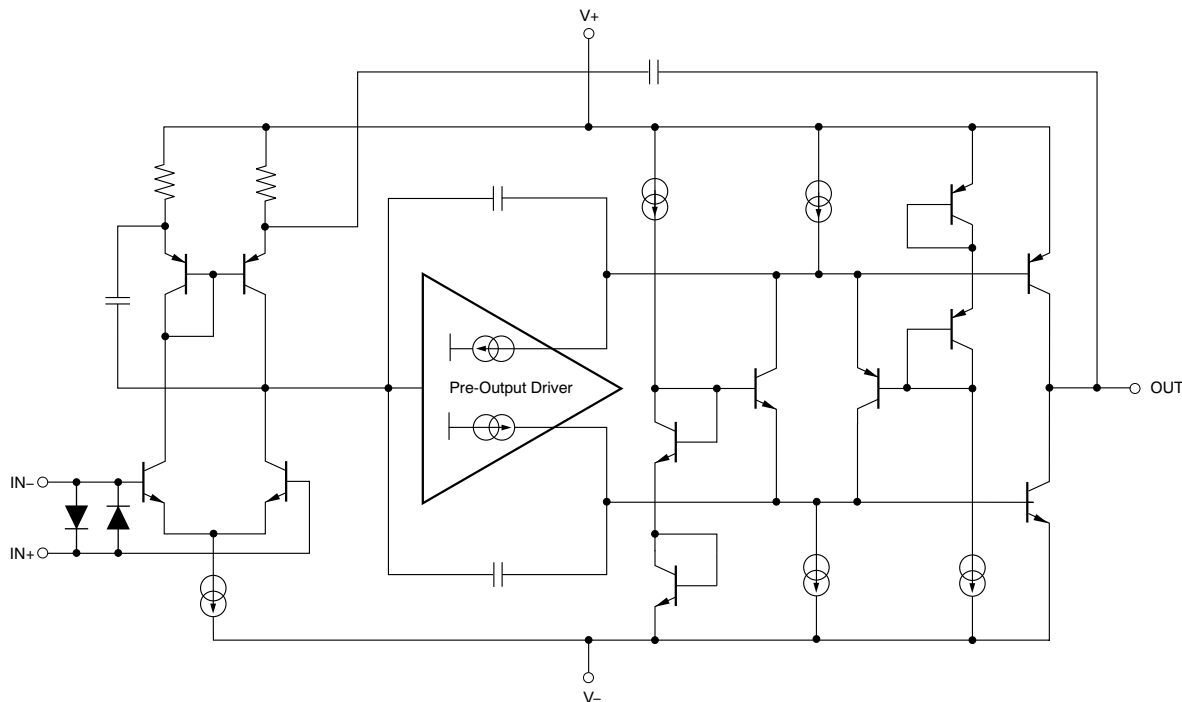

Figure 29. OPA1611 Simplified Schematic

7.3 Feature Description

7.3.1 Power Dissipation

The OPA1611 and OPA1612 series op amps are capable of driving 2-k Ω loads with a power-supply voltage up to ± 18 V. Internal power dissipation increases when operating at high supply voltages. Copper leadframe construction used in the OPA1611 and OPA1612 series op amps improves heat dissipation compared to conventional materials. Circuit board layout can also help minimize junction temperature rise. Wide copper traces help dissipate the heat by acting as an additional heat sink. Temperature rise can be further minimized by soldering the devices to the circuit board rather than using a socket.

7.3.2 Electrical Overstress

Designers often ask questions about the capability of an operational amplifier to withstand electrical overstress. These questions tend to focus on the device inputs, but may involve the supply voltage pins or even the output pin. Each of these different pin functions have electrical stress limits determined by the voltage breakdown characteristics of the particular semiconductor fabrication process and specific circuits connected to the pin. Additionally, internal electrostatic discharge (ESD) protection is built into these circuits to protect them from accidental ESD events both before and during product assembly.

Feature Description (continued)

Having a good understanding of this basic ESD circuitry and its relevance to an electrical overstress event is helpful. Figure 30 shows the ESD circuits contained in the OPA161x series (indicated by the dashed line area). The ESD protection circuitry involves several current-steering diodes connected from the input and output pins and routed back to the internal power-supply lines, where they meet at an absorption device internal to the operational amplifier. This protection circuitry is intended to remain inactive during normal circuit operation.

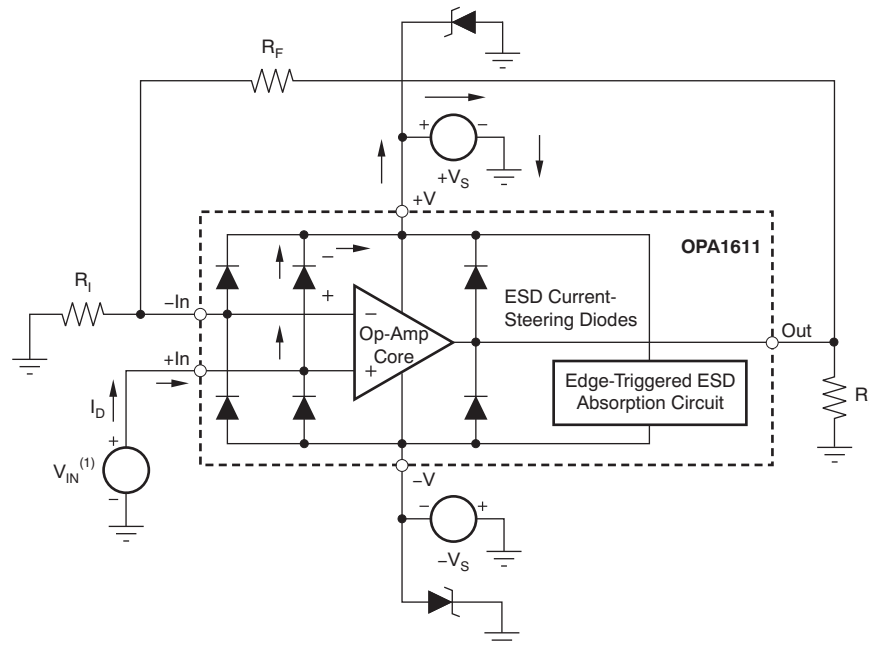

(1) $V_{IN} = +V_S + 500 \text{ mV}$.

Figure 30. Equivalent Internal ESD Circuitry and its Relation to a Typical Circuit Application

An ESD event produces a short duration, high-voltage pulse that is transformed into a short duration, high-current pulse when discharged through a semiconductor device. The ESD protection circuits are designed to provide a current path around the operational amplifier core to prevent damage to the core. The energy absorbed by the protection circuitry is then dissipated as heat.

When an ESD voltage develops across two or more of the amplifier device pins, current flows through one or more of the steering diodes. Depending on the path that the current takes, the absorption device may activate. The absorption device internal to the OPA1611 triggers when a fast ESD voltage pulse is impressed across the supply pins. Once triggered, the absorption device quickly activates and clamps the ESD pulse to a safe voltage level.

When the operational amplifier connects into a circuit such as the one Figure 30 shows, the ESD protection components are intended to remain inactive and not become involved in the application circuit operation. However, circumstances may arise where an applied voltage exceeds the operating voltage range of a given pin. If this condition occurs, some of the internal ESD protection circuits may possibly be biased on, and conduct current. Any such current flow occurs through steering diode paths and rarely involves the absorption device.

Figure 30 shows a specific example where the input voltage, V_{IN} , exceeds the positive supply voltage ($+V_S$) by 500 mV or more. Much of what happens in the circuit depends on the supply characteristics. If $+V_S$ can sink the current, one of the upper input steering diodes conducts and directs current to $+V_S$. Excessively high current levels can flow with increasingly higher V_{IN} . As a result, the datasheet specifications recommend that applications limit the input current to 10 mA.

Feature Description (continued)

If the supply is not capable of sinking the current, V_{IN} may begin sourcing current to the operational amplifier, and then take over as the source of positive supply voltage. The danger in this case is that the voltage can rise to levels that exceed the operational amplifier absolute maximum ratings. In extreme but rare cases, the absorption device triggers on while $+V_S$ and $-V_S$ are applied. If this event happens, a direct current path is established between the $+V_S$ and $-V_S$ supplies. The power dissipation of the absorption device is quickly exceeded, and the extreme internal heating destroys the operational amplifier.

Another common question involves what happens to the amplifier if an input signal is applied to the input while the power supplies $+V_S$ or $-V_S$ are at 0 V. Again, the result depends on the supply characteristic while at 0 V, or at a level below the input signal amplitude. If the supplies appear as high impedance, then the operational amplifier supply current may be supplied by the input source via the current steering diodes. This state is not a normal bias condition; the amplifier most likely does not operate normally. If the supplies are low impedance, then the current through the steering diodes can become quite high. The current level depends on the ability of the input source to deliver current, and any resistance in the input path.

If there is an uncertainty about the ability of the supply to absorb this current, external zener diodes may be added to the supply pins; see [Figure 30](#). The zener voltage must be selected such that the diode does not turn on during normal operation. However, the zener diode voltage must be low enough so that the zener diode conducts if the supply pin begins to rise above the safe operating supply voltage level.

7.3.3 Operating Voltage

The OPA161x series op amps operate from ± 2.25 -V to ± 18 -V supplies while maintaining excellent performance. The OPA161x series can operate with as little as +4.5 V between the supplies and with up to +36 V between the supplies. However, some applications do not require equal positive and negative output voltage swing. With the OPA161x series, power-supply voltages do not need to be equal. For example, the positive supply could be set to +25 V with the negative supply at -5 V.

In all cases, the common-mode voltage must be maintained within the specified range. In addition, key parameters are assured over the specified temperature range of $T_A = -40^\circ\text{C}$ to $+85^\circ\text{C}$. Parameters that vary with operating voltage or temperature are shown in the [Typical Characteristics](#).

7.3.4 Input Protection

The input terminals of the OPA1611 and the OPA1612 are protected from excessive differential voltage with back-to-back diodes, as [Figure 31](#) shows. In most circuit applications, the input protection circuitry has no consequence. However, in low-gain or $G = +1$ circuits, fast ramping input signals can forward bias these diodes because the output of the amplifier cannot respond rapidly enough to the input ramp. This effect is illustrated in [Figure 17](#) of the Typical Characteristics. If the input signal is fast enough to create this forward bias condition, the input signal current must be limited to 10 mA or less. If the input signal current is not inherently limited, an input series resistor (R_I) or a feedback resistor (R_F) can be used to limit the signal input current. This input series resistor degrades the low-noise performance of the OPA1611 and is examined in the [Noise Performance](#) section. [Figure 31](#) shows an example configuration when both current-limiting input and feedback resistors are used.

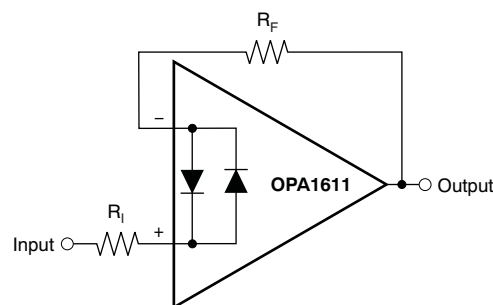

Figure 31. Pulsed Operation

8 Application and Implementation

8.1 Application Information

The OPA1611 and OPA1612 are unity-gain stable, precision op amps with very low noise; these devices are also free from output phase reversal. Applications with noisy or high-impedance power supplies require decoupling capacitors close to the device power-supply pins. In most cases, 0.1- μ F capacitors are adequate.

8.2 Noise Performance

Figure 32 shows the total circuit noise for varying source impedances with the op amp in a unity-gain configuration (no feedback resistor network, and therefore no additional noise contributions).

The OPA1611 (GBW = 40 MHz, G = +1) is shown with total circuit noise calculated. The op amp itself contributes both a voltage noise component and a current noise component. The voltage noise is commonly modeled as a time-varying component of the offset voltage. The current noise is modeled as the time-varying component of the input bias current and reacts with the source resistance to create a voltage component of noise. Therefore, the lowest noise op amp for a given application depends on the source impedance. For low source impedance, current noise is negligible, and voltage noise generally dominates. The low voltage noise of the OPA161x series op amps makes them a good choice for use in applications where the source impedance is less than 1 k Ω .

8.2.1 Detailed Design Procedure

The equation in Figure 32 shows the calculation of the total circuit noise, with these parameters:

- e_n = voltage noise
- I_n = current noise
- R_S = source impedance
- k = Boltzmann's constant = 1.38×10^{-23} J/K
- T = temperature in degrees Kelvin (K)

8.2.2 Application Curve

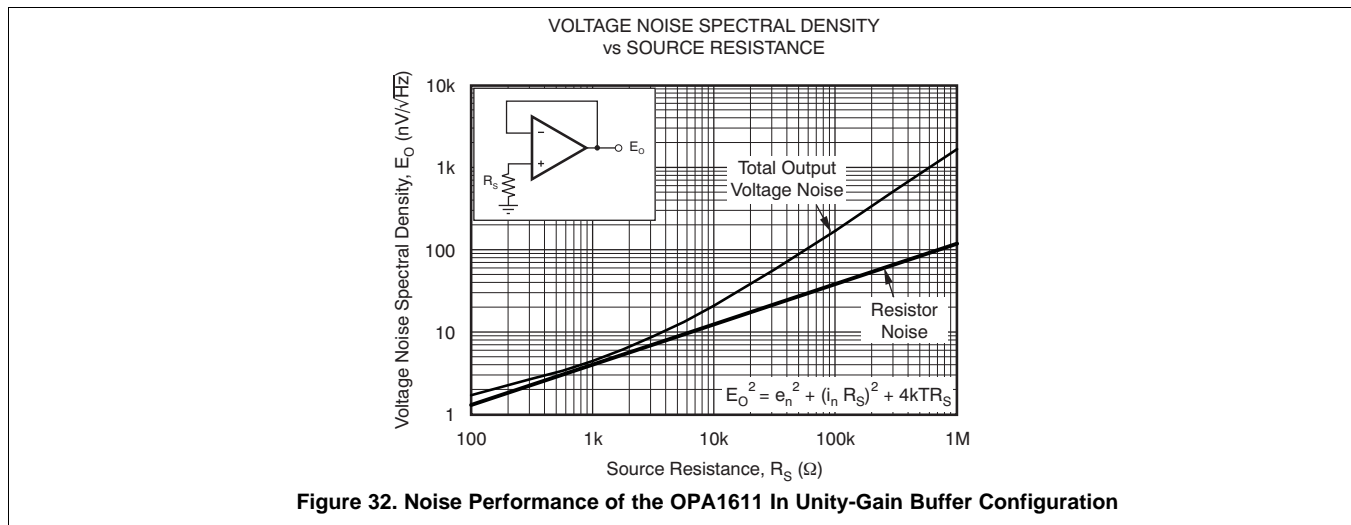

8.2.3 Basic Noise Calculations

Design of low-noise op amp circuits requires careful consideration of a variety of possible noise contributors: noise from the signal source, noise generated in the op amp, and noise from the feedback network resistors. The total noise of the circuit is the root-sum-square combination of all noise components.

The resistive portion of the source impedance produces thermal noise proportional to the square root of the resistance. Figure 32 plots this function. The source impedance is usually fixed; consequently, select the op amp and the feedback resistors to minimize the respective contributions to the total noise.

Noise Performance (continued)

Figure 33 shows both inverting and noninverting op amp circuit configurations with gain. In circuit configurations with gain, the feedback network resistors also contribute noise.

The current noise of the op amp reacts with the feedback resistors to create additional noise components. The feedback resistor values can generally be chosen to make these noise sources negligible. The equations for total noise are shown for both configurations.

Noise in Noninverting Gain Configuration

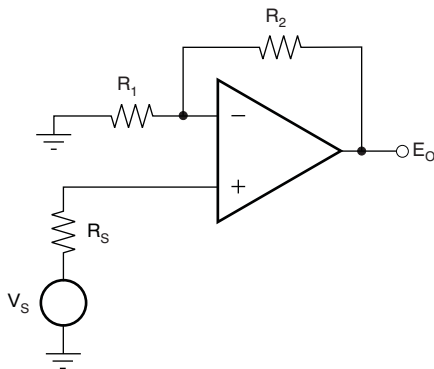

Noise at the output:

$$E_O^2 = \left[1 + \frac{R_2}{R_1} \right]^2 e_n^2 + e_1^2 + e_2^2 + (i_n R_2)^2 + e_S^2 + (i_n R_S)^2 \left[1 + \frac{R_2}{R_1} \right]^2$$

Where $e_S = \sqrt{4kTR_S} \times \left[1 + \frac{R_2}{R_1} \right]$ = thermal noise of R_S

$e_1 = \sqrt{4kTR_1} \times \left[\frac{R_2}{R_1} \right]$ = thermal noise of R_1

$e_2 = \sqrt{4kTR_2}$ = thermal noise of R_2

Noise in Inverting Gain Configuration

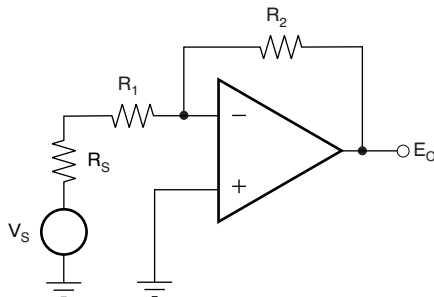

Noise at the output:

$$E_O^2 = \left[1 + \frac{R_2}{R_1 + R_S} \right]^2 e_n^2 + e_1^2 + e_2^2 + (i_n R_2)^2 + e_S^2$$

Where $e_S = \sqrt{4kTR_S} \times \left[\frac{R_2}{R_1 + R_S} \right]$ = thermal noise of R_S

$e_1 = \sqrt{4kTR_1} \times \left[\frac{R_2}{R_1 + R_S} \right]$ = thermal noise of R_1

$e_2 = \sqrt{4kTR_2}$ = thermal noise of R_2

For the OPA161x series op amps at 1 kHz, $e_n = 1.1 \text{ nV}/\sqrt{\text{Hz}}$ and $i_n = 1.7 \text{ pA}/\sqrt{\text{Hz}}$.

Figure 33. Noise Calculation in Gain Configurations

8.3 Total Harmonic Distortion Measurements

The OPA161x series op amps have excellent distortion characteristics. THD + noise is below 0.00008% ($G = +1$, $V_O = 3 V_{RMS}$, $BW = 80$ kHz) throughout the audio frequency range, 20 Hz to 20 kHz, with a 2-k Ω load (see [Figure 7](#) for characteristic performance).

The distortion produced by OPA1611 series op amps is below the measurement limit of many commercially available distortion analyzers. However, a special test circuit (such as [Figure 34](#) shows) can be used to extend the measurement capabilities.

Op amp distortion can be considered an internal error source that can be referred to the input. [Figure 34](#) shows a circuit that causes the op amp distortion to be 101 times (or approximately 40 dB) greater than that normally produced by the op amp. The addition of R_3 to the otherwise standard noninverting amplifier configuration alters the feedback factor or noise gain of the circuit. The closed-loop gain is unchanged, but the feedback available for error correction is reduced by a factor of 101, thus extending the resolution by 101. Note that the input signal and load applied to the op amp are the same as with conventional feedback without R_3 . Keep the value of R_3 small to minimize its effect on the distortion measurements.

Validity of this technique can be verified by duplicating measurements at high gain and/or high frequency where the distortion is within the measurement capability of the test equipment. Measurements for this data sheet were made with an audio precision system two distortion and noise analyzer, which greatly simplifies such repetitive measurements. The measurement technique can, however, be performed with manual distortion measurement instruments.

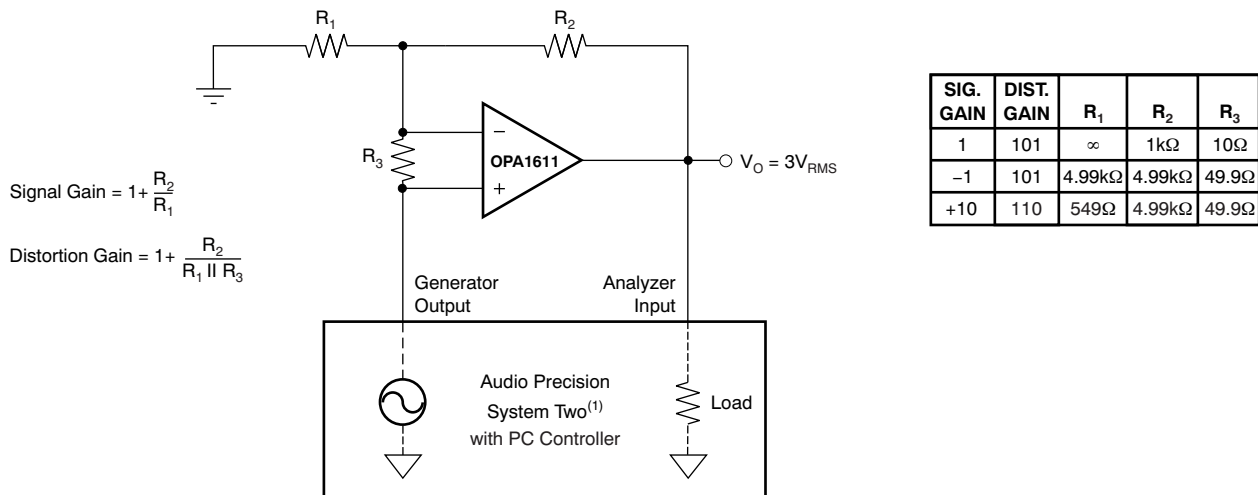

(1) For measurement bandwidth, see [Figure 7](#) through [Figure 12](#).

Figure 34. Distortion Test Circuit

8.4 Capacitive Loads

The dynamic characteristics of the OPA1611 and OPA1612 have been optimized for commonly encountered gains, loads, and operating conditions. The combination of low closed-loop gain and high capacitive loads decreases the phase margin of the amplifier and can lead to gain peaking or oscillations. As a result, heavier capacitive loads must be isolated from the output. The simplest way to achieve this isolation is to add a small resistor (R_S equal to 50 Ω , for example) in series with the output.

This small series resistor also prevents excess power dissipation if the output of the device becomes shorted. [Figure 19](#) and [Figure 20](#) illustrate graphs of *Small-Signal Overshoot vs Capacitive Load* for several values of R_S . Also, refer to [Applications Bulletin AB-028, Feedback Plots Define Op Amp AC Performance \(SBOA015\)](#), available for download from the TI web site, for details of analysis techniques and application circuits.

8.5 Application Circuit

Figure 35 shows how to use the OPA1611 as an amplifier for professional audio headphones. The circuit shows the left side stereo channel. An identical circuit is used to drive the right side stereo channel.

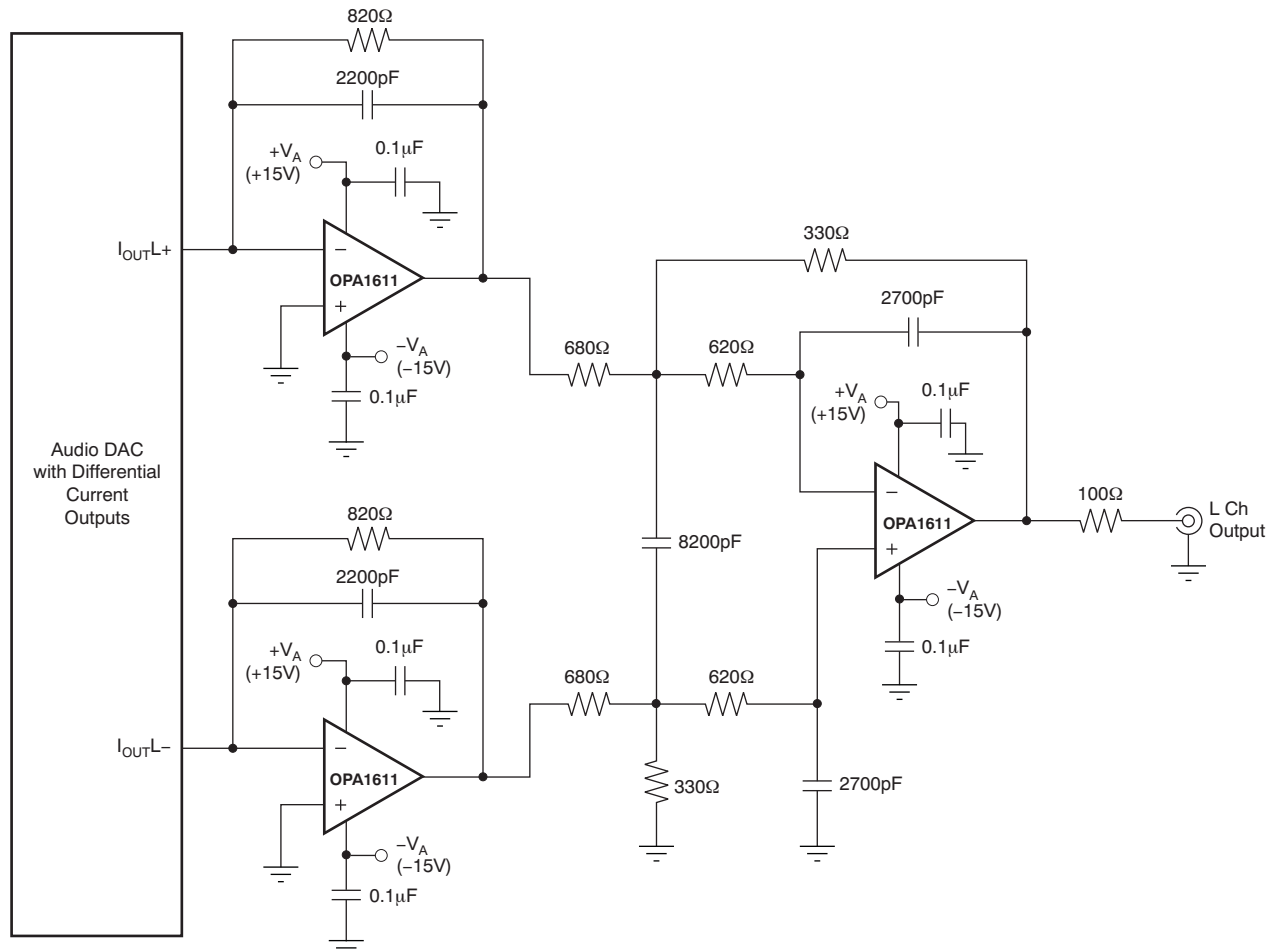

Figure 35. Audio DAC Post Filter (I/V Converter and Low-Pass Filter)

9 Power-Supply Recommendations

The OPA161x is specified for operation from 4.5 V to 36 V (± 2.25 V to ± 18 V); many specifications apply from -40°C to $+85^{\circ}\text{C}$. Parameters that can exhibit significant variance with regard to operating voltage or temperature are presented in the [Typical Characteristics](#) section.

CAUTION

Supply voltages larger than 40 V can permanently damage the device; see the [Absolute Maximum Ratings](#).

Place 0.1- μF bypass capacitors close to the power-supply pins to reduce errors coupling in from noisy or high-impedance power supplies. For more detailed information on bypass capacitor placement, refer to the [Typical Characteristics](#) section.

10 Layout

10.1 Layout Guidelines

For best operational performance of the device, use good printed circuit board (PCB) layout practices, including:

- Noise can propagate into analog circuitry through the power pins of the circuit as a whole and the op amp itself. Bypass capacitors are used to reduce the coupled noise by providing low-impedance power sources local to the analog circuitry.
 - Connect low-ESR, 0.1- μ F ceramic bypass capacitors between each supply pin and ground, placed as close to the device as possible. A single bypass capacitor from V+ to ground is applicable for single-supply applications.
- Separate grounding for analog and digital portions of the circuitry is one of the simplest and most-effective methods of noise suppression. One or more layers on multilayer PCBs are usually devoted to ground planes. A ground plane helps distribute heat and reduces EMI noise pickup. Make sure to physically separate digital and analog grounds while paying attention to the flow of the ground current. For more detailed information, refer to the application report [Circuit Board Layout Techniques \(SLOA089\)](#).
- In order to reduce parasitic coupling, run the input traces as far away from the supply or output traces as possible. If these traces cannot be kept separate, crossing the sensitive trace perpendicular as opposed to in parallel with the noisy trace is the preferred method.
- Place the external components as close to the device as possible. As shown in [Figure 36](#), keeping RF and RG close to the inverting input minimizes parasitic capacitance.
- Keep the length of input traces as short as possible. Always remember that the input traces are the most sensitive part of the circuit.
- Consider a driven, low-impedance guard ring around the critical traces. A guard ring can significantly reduce leakage currents from nearby traces that are at different potentials.

10.2 Layout Example

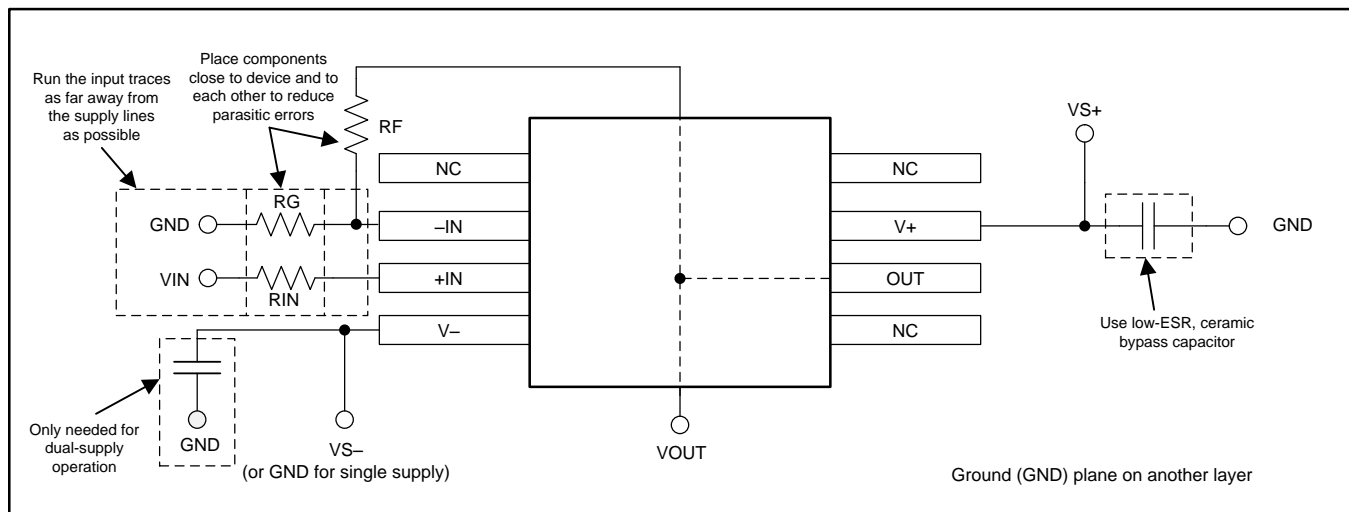
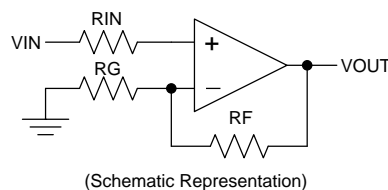

Figure 36. Operational Amplifier Board Layout for a Noninverting Configuration

11 Device and Documentation Support

11.1 Documentation Support

11.1.1 Related Documentation

For related documentation see the following:

- *Feedback Plots Define Op Amp AC Performance* , [SBOA015](#)
- *Circuit Board Layout Techniques*, [SLOA089](#)

11.2 Related Links

The table below lists quick access links. Categories include technical documents, support and community resources, tools and software, and quick access to sample or buy.

Table 1. Related Links

PARTS	PRODUCT FOLDER	SAMPLE & BUY	TECHNICAL DOCUMENTS	TOOLS & SOFTWARE	SUPPORT & COMMUNITY
OPA1611	Click here	Click here	Click here	Click here	Click here
OPA1612	Click here	Click here	Click here	Click here	Click here

11.3 Trademarks

SoundPlus is a trademark of Texas Instruments, Inc.
All other trademarks are the property of their respective owners.

11.4 Electrostatic Discharge Caution



These devices have limited built-in ESD protection. The leads should be shorted together or the device placed in conductive foam during storage or handling to prevent electrostatic damage to the MOS gates.

11.5 Glossary

[SLYZ022](#) — *TI Glossary*.

This glossary lists and explains terms, acronyms, and definitions.

12 Mechanical, Packaging, and Orderable Information

The following pages include mechanical, packaging, and orderable information. This information is the most current data available for the designated devices. This data is subject to change without notice and revision of this document. For browser-based versions of this data sheet, refer to the left-hand navigation.

PACKAGING INFORMATION

Orderable Device	Status (1)	Package Type	Package Drawing	Pins	Package Qty	Eco Plan (2)	Lead finish/ Ball material (6)	MSL Peak Temp (3)	Op Temp (°C)	Device Marking (4/5)	Samples
OPA1611AID	ACTIVE	SOIC	D	8	75	RoHS & Green	NIPDAU	Level-2-260C-1 YEAR	-40 to 85	OPA 1611A	Samples
OPA1611AIDR	ACTIVE	SOIC	D	8	2500	RoHS & Green	NIPDAU	Level-2-260C-1 YEAR	-40 to 85	OPA 1611A	Samples
OPA1612AID	ACTIVE	SOIC	D	8	75	RoHS & Green	NIPDAU	Level-2-260C-1 YEAR	-40 to 85	OPA 1612A	Samples
OPA1612AIDR	ACTIVE	SOIC	D	8	2500	RoHS & Green	NIPDAU	Level-2-260C-1 YEAR	-40 to 85	OPA 1612A	Samples
OPA1612AIDRGR	ACTIVE	SON	DRG	8	3000	RoHS & Green	NIPDAU	Level-2-260C-1 YEAR	-40 to 85	OVII	Samples
OPA1612AIDRGT	ACTIVE	SON	DRG	8	250	RoHS & Green	NIPDAU	Level-2-260C-1 YEAR	-40 to 85	OVII	Samples

(1) The marketing status values are defined as follows:

ACTIVE: Product device recommended for new designs.

LIFEBUY: TI has announced that the device will be discontinued, and a lifetime-buy period is in effect.

NRND: Not recommended for new designs. Device is in production to support existing customers, but TI does not recommend using this part in a new design.

PREVIEW: Device has been announced but is not in production. Samples may or may not be available.

OBSOLETE: TI has discontinued the production of the device.

(2) **RoHS:** TI defines "RoHS" to mean semiconductor products that are compliant with the current EU RoHS requirements for all 10 RoHS substances, including the requirement that RoHS substance do not exceed 0.1% by weight in homogeneous materials. Where designed to be soldered at high temperatures, "RoHS" products are suitable for use in specified lead-free processes. TI may reference these types of products as "Pb-Free".

RoHS Exempt: TI defines "RoHS Exempt" to mean products that contain lead but are compliant with EU RoHS pursuant to a specific EU RoHS exemption.

Green: TI defines "Green" to mean the content of Chlorine (Cl) and Bromine (Br) based flame retardants meet JS709B low halogen requirements of <=1000ppm threshold. Antimony trioxide based flame retardants must also meet the <=1000ppm threshold requirement.

(3) MSL, Peak Temp. - The Moisture Sensitivity Level rating according to the JEDEC industry standard classifications, and peak solder temperature.

(4) There may be additional marking, which relates to the logo, the lot trace code information, or the environmental category on the device.

(5) Multiple Device Markings will be inside parentheses. Only one Device Marking contained in parentheses and separated by a "~" will appear on a device. If a line is indented then it is a continuation of the previous line and the two combined represent the entire Device Marking for that device.

⁽⁶⁾ Lead finish/Ball material - Orderable Devices may have multiple material finish options. Finish options are separated by a vertical ruled line. Lead finish/Ball material values may wrap to two lines if the finish value exceeds the maximum column width.

Important Information and Disclaimer:The information provided on this page represents TI's knowledge and belief as of the date that it is provided. TI bases its knowledge and belief on information provided by third parties, and makes no representation or warranty as to the accuracy of such information. Efforts are underway to better integrate information from third parties. TI has taken and continues to take reasonable steps to provide representative and accurate information but may not have conducted destructive testing or chemical analysis on incoming materials and chemicals. TI and TI suppliers consider certain information to be proprietary, and thus CAS numbers and other limited information may not be available for release.

In no event shall TI's liability arising out of such information exceed the total purchase price of the TI part(s) at issue in this document sold by TI to Customer on an annual basis.

OTHER QUALIFIED VERSIONS OF OPA1612 :

- Automotive: [OPA1612-Q1](#)

NOTE: Qualified Version Definitions:

- Automotive - Q100 devices qualified for high-reliability automotive applications targeting zero defects

TAPE AND REEL INFORMATION

QUADRANT ASSIGNMENTS FOR PIN 1 ORIENTATION IN TAPE

*All dimensions are nominal

Device	Package Type	Package Drawing	Pins	SPQ	Reel Diameter (mm)	Reel Width W1 (mm)	A0 (mm)	B0 (mm)	K0 (mm)	P1 (mm)	W (mm)	Pin1 Quadrant
OPA1611AIDR	SOIC	D	8	2500	330.0	12.4	6.4	5.2	2.1	8.0	12.0	Q1
OPA1612AIDR	SOIC	D	8	2500	330.0	12.4	6.4	5.2	2.1	8.0	12.0	Q1
OPA1612AIDRGR	SON	DRG	8	3000	330.0	12.4	3.3	3.3	1.1	8.0	12.0	Q2
OPA1612AIDRGT	SON	DRG	8	250	180.0	12.4	3.3	3.3	1.1	8.0	12.0	Q2

TAPE AND REEL BOX DIMENSIONS



*All dimensions are nominal

Device	Package Type	Package Drawing	Pins	SPQ	Length (mm)	Width (mm)	Height (mm)
OPA1611AIDR	SOIC	D	8	2500	356.0	356.0	35.0
OPA1612AIDR	SOIC	D	8	2500	356.0	356.0	35.0
OPA1612AIDRGR	SON	DRG	8	3000	356.0	356.0	35.0
OPA1612AIDRGT	SON	DRG	8	250	210.0	185.0	35.0

TUBE

*All dimensions are nominal

Device	Package Name	Package Type	Pins	SPQ	L (mm)	W (mm)	T (μm)	B (mm)
OPA1611AID	D	SOIC	8	75	506.6	8	3940	4.32
OPA1612AID	D	SOIC	8	75	506.6	8	3940	4.32



D0008A

PACKAGE OUTLINE

SOIC - 1.75 mm max height

SMALL OUTLINE INTEGRATED CIRCUIT



4214825/C 02/2019

NOTES:

1. Linear dimensions are in inches [millimeters]. Dimensions in parenthesis are for reference only. Controlling dimensions are in inches. Dimensioning and tolerancing per ASME Y14.5M.
2. This drawing is subject to change without notice.
3. This dimension does not include mold flash, protrusions, or gate burrs. Mold flash, protrusions, or gate burrs shall not exceed $.006$ [0.15] per side.
4. This dimension does not include interlead flash.
5. Reference JEDEC registration MS-012, variation AA.

EXAMPLE BOARD LAYOUT

D0008A

SOIC - 1.75 mm max height

SMALL OUTLINE INTEGRATED CIRCUIT



LAND PATTERN EXAMPLE
EXPOSED METAL SHOWN
SCALE:8X



SOLDER MASK DETAILS

4214825/C 02/2019

NOTES: (continued)

6. Publication IPC-7351 may have alternate designs.

7. Solder mask tolerances between and around signal pads can vary based on board fabrication site.

EXAMPLE STENCIL DESIGN

D0008A

SOIC - 1.75 mm max height

SMALL OUTLINE INTEGRATED CIRCUIT



SOLDER PASTE EXAMPLE
BASED ON .005 INCH [0.125 MM] THICK STENCIL
SCALE:8X

4214825/C 02/2019

NOTES: (continued)

8. Laser cutting apertures with trapezoidal walls and rounded corners may offer better paste release. IPC-7525 may have alternate design recommendations.
9. Board assembly site may have different recommendations for stencil design.

DRG (S-PWSON-N8)

PLASTIC SMALL OUTLINE NO-LEAD

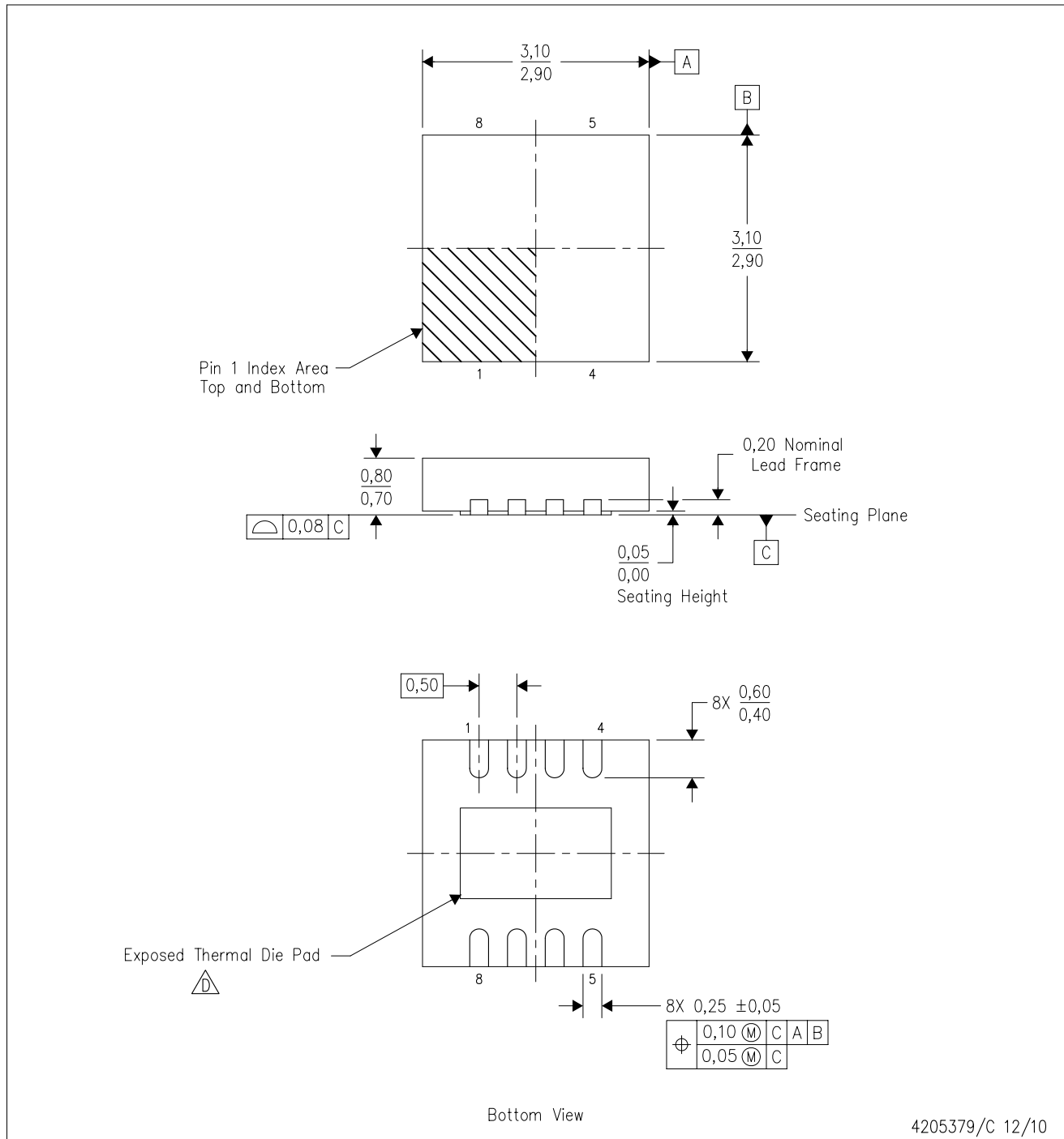

- NOTES:
- A. All linear dimensions are in millimeters. Dimensioning and tolerancing per ASME Y14.5M-1994.
 - B. This drawing is subject to change without notice.
 - C. SON (Small Outline No-Lead) package configuration.
 - D. The package thermal pad must be soldered to the board for thermal and mechanical performance. See the Product Data Sheet for details regarding the exposed thermal pad dimensions.
 - E. JEDEC MO-229 package registration pending.

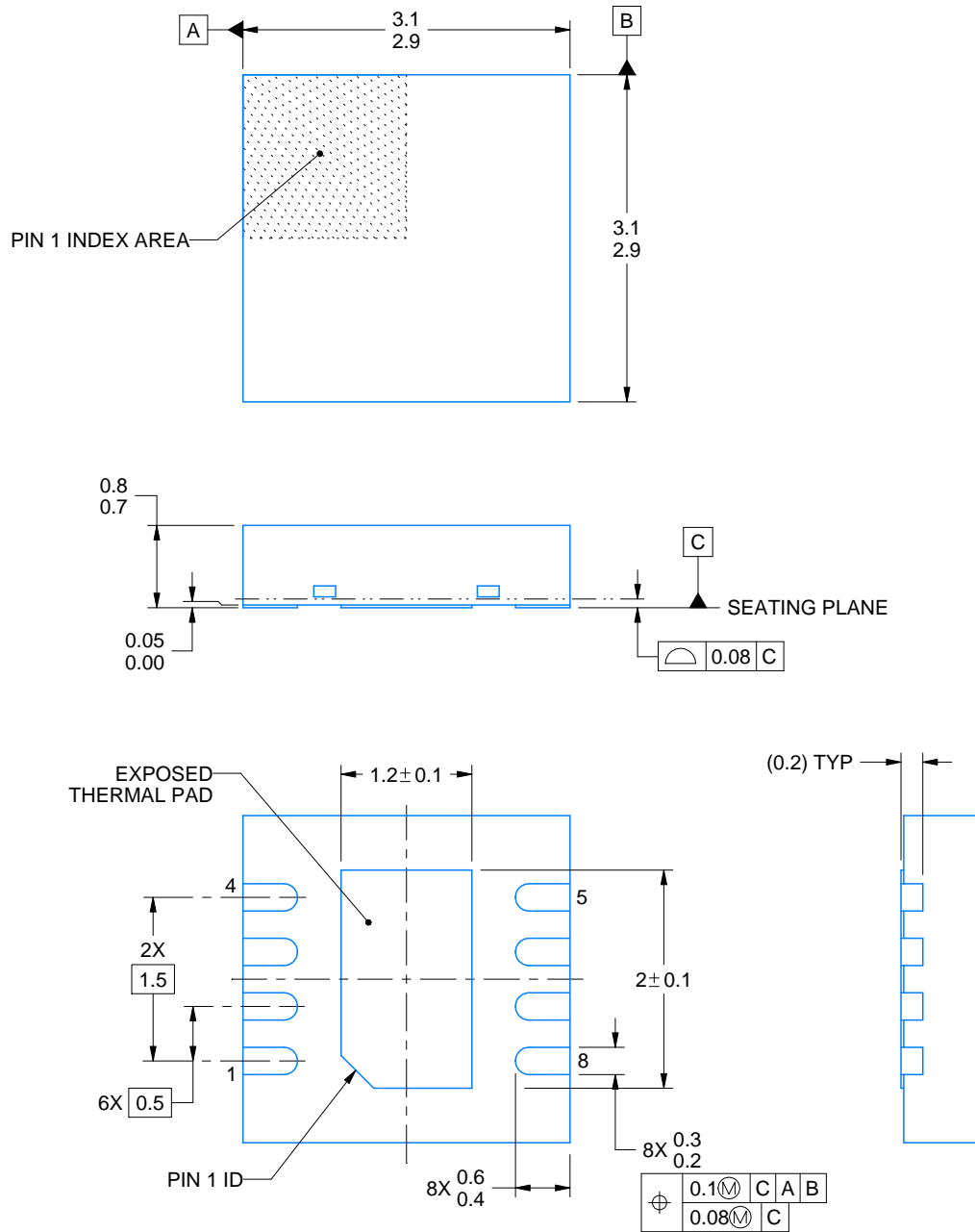
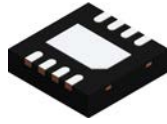

4218885/A 03/2020

NOTES:

1. All linear dimensions are in millimeters. Any dimensions in parenthesis are for reference only. Dimensioning and tolerancing per ASME Y14.5M.
2. This drawing is subject to change without notice.
3. The package thermal pad must be soldered to the printed circuit board for thermal and mechanical performance.

EXAMPLE BOARD LAYOUT

DRG0008A

WSON - 0.8 mm max height

PLASTIC SMALL OUTLINE - NO LEAD

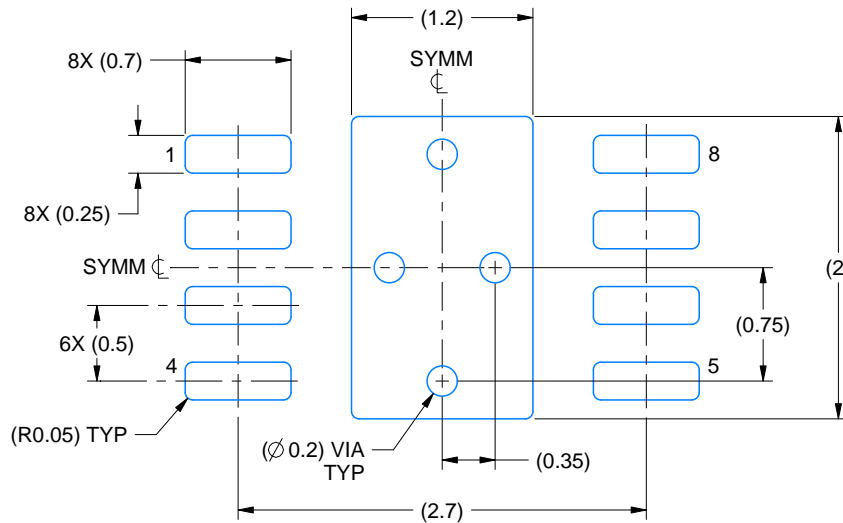

LAND PATTERN EXAMPLE
EXPOSED METAL SHOWN
SCALE:20X

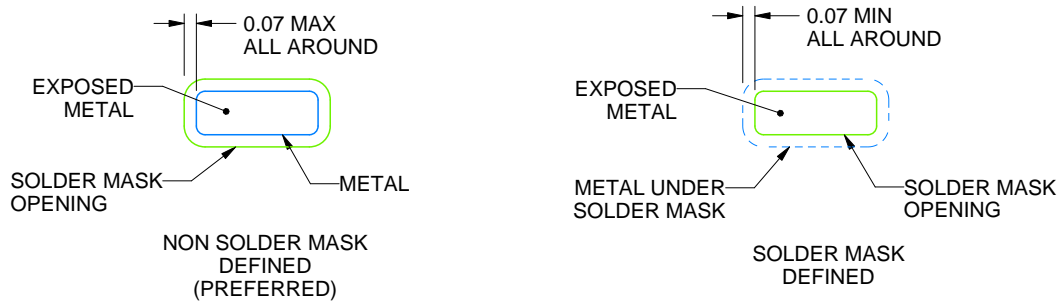

SOLDER MASK DETAILS

4218885/A 03/2020

NOTES: (continued)

4. This package is designed to be soldered to a thermal pad on the board. For more information, see Texas Instruments literature number SLUA271 (www.ti.com/lit/slua271).
5. Vias are optional depending on application, refer to device data sheet. If any vias are implemented, refer to their locations shown on this view. It is recommended that vias under paste be filled, plugged or tented.

EXAMPLE STENCIL DESIGN

DRG0008A

WSO - 0.8 mm max height

PLASTIC SMALL OUTLINE - NO LEAD

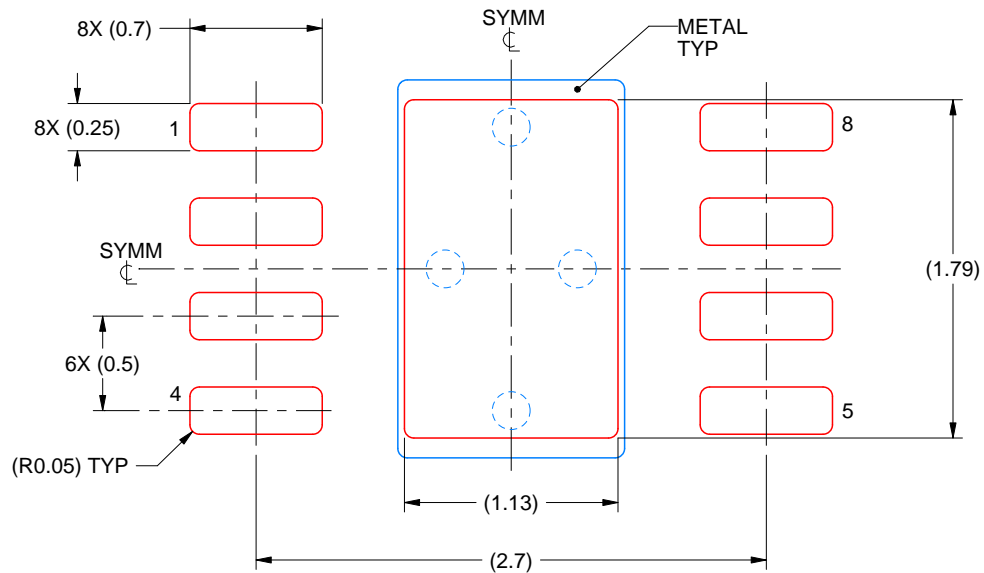

SOLDER PASTE EXAMPLE
BASED ON 0.125 mm THICK STENCIL

EXPOSED PAD
84% PRINTED SOLDER COVERAGE BY AREA
SCALE:25X

4218885/A 03/2020

NOTES: (continued)

6. Laser cutting apertures with trapezoidal walls and rounded corners may offer better paste release. IPC-7525 may have alternate design recommendations.

IMPORTANT NOTICE AND DISCLAIMER

TI PROVIDES TECHNICAL AND RELIABILITY DATA (INCLUDING DATA SHEETS), DESIGN RESOURCES (INCLUDING REFERENCE DESIGNS), APPLICATION OR OTHER DESIGN ADVICE, WEB TOOLS, SAFETY INFORMATION, AND OTHER RESOURCES "AS IS" AND WITH ALL FAULTS, AND DISCLAIMS ALL WARRANTIES, EXPRESS AND IMPLIED, INCLUDING WITHOUT LIMITATION ANY IMPLIED WARRANTIES OF MERCHANTABILITY, FITNESS FOR A PARTICULAR PURPOSE OR NON-INFRINGEMENT OF THIRD PARTY INTELLECTUAL PROPERTY RIGHTS.

These resources are intended for skilled developers designing with TI products. You are solely responsible for (1) selecting the appropriate TI products for your application, (2) designing, validating and testing your application, and (3) ensuring your application meets applicable standards, and any other safety, security, regulatory or other requirements.

These resources are subject to change without notice. TI grants you permission to use these resources only for development of an application that uses the TI products described in the resource. Other reproduction and display of these resources is prohibited. No license is granted to any other TI intellectual property right or to any third party intellectual property right. TI disclaims responsibility for, and you will fully indemnify TI and its representatives against, any claims, damages, costs, losses, and liabilities arising out of your use of these resources.

TI's products are provided subject to [TI's Terms of Sale](#) or other applicable terms available either on ti.com or provided in conjunction with such TI products. TI's provision of these resources does not expand or otherwise alter TI's applicable warranties or warranty disclaimers for TI products.

TI objects to and rejects any additional or different terms you may have proposed.

Mailing Address: Texas Instruments, Post Office Box 655303, Dallas, Texas 75265
Copyright © 2022, Texas Instruments Incorporated

Looking for pricing, stock, or lifecycle information?

Click below to explore more details on WIN SOURCE:

 [View OPA1611AIDR on WIN SOURCE](#)

 [Texas Instruments](#) Information

Optimize Your Supply Chain with WIN SOURCE Solutions

-  Global Sourcing Solution
-  Obsolete Management
-  Cost Control Management
-  Shortage Management
-  Alternative Solution
-  Excess Inventory Management