



# THE DATASHEET OF OPA2228P





## OPAx22x High Precision, Low Noise Operational Amplifiers

### 1 Features

- Low Noise:  $3\text{nV}/\sqrt{\text{Hz}}$
- Wide Bandwidth:
  - OPA227: 8 MHz, 2.3 V/ $\mu\text{s}$
  - OPA228: 33 MHz, 10 V/ $\mu\text{s}$
- Settling Time: 5  $\mu\text{s}$   
(Significant Improvement Over OP-27)
- High CMRR: 138 dB
- High Open-loop Gain: 160 dB
- Low Input Bias Current: 10 nA Maximum
- Low Offset Voltage: 75  $\mu\text{V}$  Maximum
- Wide Supply Range:  $\pm 2.5\text{ V}$  to  $\pm 18\text{ V}$
- OPA227 Replaces OP-27, LT1007, MAX427
- OPA228 Replaces OP-37, LT1037, MAX437
- Single, Dual, and Quad Versions

### 2 Applications

- Data Acquisition
- Telecom Equipment
- Geophysical Analysis
- Vibration Analysis
- Spectral Analysis
- Professional Audio Equipment
- Active Filters
- Power Supply Controls

### 3 Description

The OPAx22x series operational amplifiers combine low noise and wide bandwidth with high precision to make them the ideal choice for applications requiring both AC and precision DC performance.

The OPAx227 is unity-gain stable and features high slew rate (2.3V/ $\mu\text{s}$ ) and wide bandwidth (8MHz). The OPAx228 is optimized for closed-loop gains of 5 or greater, and offers higher speed with a slew rate of 10V/ $\mu\text{s}$  and a bandwidth of 33MHz.

The OPAx227 and OPAx228 series operational amplifiers are ideal for professional audio equipment. In addition, low quiescent current and low cost make them ideal for portable applications requiring high precision.

The OPAx227 and OPAx228 series operational amplifiers are pin-for-pin replacements for the industry standard OP-27 and OP-37 with substantial improvements across the board. The dual and quad versions are available for space savings and per channel cost reduction.

The OPAx227, OPAx228, are available in DIP-8 and SO-8 packages. The OPA4227 and OPA4228 are available in DIP-14 and SO-14 packages with standard pin configurations. Operation is specified from  $-40^{\circ}\text{C}$  to  $85^{\circ}\text{C}$ .

#### Device Information<sup>(1)</sup>

PART NUMBER	PACKAGE	BODY SIZE (NOM)
OPA227	PDIP (8)	9.81 mm x 6.35 mm
OPA228	SOIC (8)	4.90 mm x 3.91 mm
OPA2227	PDIP (8)	9.81 mm x 6.35 mm
OPA2228	SOIC (8)	4.90 mm x 3.91 mm
OPA4227	PDIP (14)	19.30 mm x 6.35 mm
OPA4228	SOIC (14)	8.65 mm x 3.91 mm

(1) For all available packages, see the orderable addendum at the end of the data sheet.

#### Input Referred Noise

INPUT VOLTAGE AND CURRENT NOISE  
SPECTRAL DENSITY vs FREQUENCY

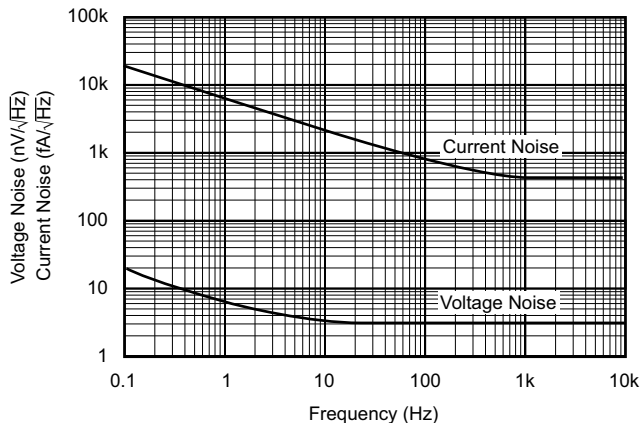

## Table of Contents

<b>1 Features</b> .....	<b>1</b>	7.2 Functional Block Diagram .....	<b>16</b>
<b>2 Applications</b> .....	<b>1</b>	7.3 Feature Description .....	<b>16</b>
<b>3 Description</b> .....	<b>1</b>	7.4 Device Functional Modes .....	<b>23</b>
<b>4 Revision History</b> .....	<b>2</b>	<b>8 Application and Implementation</b> .....	<b>24</b>
<b>5 Pin Configuration and Functions</b> .....	<b>3</b>	8.1 Application Information .....	<b>24</b>
<b>6 Specifications</b> .....	<b>5</b>	8.2 Typical Application .....	<b>26</b>
6.1 Absolute Maximum Ratings .....	<b>5</b>	<b>9 Power Supply Recommendations</b> .....	<b>29</b>
6.2 ESD Ratings .....	<b>5</b>	<b>10 Layout</b> .....	<b>29</b>
6.3 Recommended Operating Conditions .....	<b>5</b>	10.1 Layout Guidelines .....	<b>29</b>
6.4 Thermal Information: OPA227U/UA and OPA228U/UA .....	<b>5</b>	10.2 Layout Example .....	<b>30</b>
6.5 Thermal Information: OPA227P/PA and OPA228P/PA .....	<b>6</b>	<b>11 Device and Documentation Support</b> .....	<b>31</b>
6.6 Electrical Characteristics: OPAx227 Series ( $V_S = \pm 5$ V to $\pm 15$ V) .....	<b>7</b>	11.1 Device Support .....	<b>31</b>
6.7 Electrical Characteristics: OPAx228 Series ( $V_S = \pm 5$ V to $\pm 15$ V) .....	<b>8</b>	11.2 Documentation Support .....	<b>31</b>
6.8 Typical Characteristics .....	<b>10</b>	11.3 Related Links .....	<b>31</b>
<b>7 Detailed Description</b> .....	<b>16</b>	11.4 Trademarks .....	<b>31</b>
7.1 Overview .....	<b>16</b>	11.5 Electrostatic Discharge Caution .....	<b>32</b>
		11.6 Glossary .....	<b>32</b>
		<b>12 Mechanical, Packaging, and Orderable Information</b> .....	<b>32</b>

## 4 Revision History

NOTE: Page numbers for previous revisions may differ from page numbers in the current version.

Changes from Revision A (January 2005) to Revision B	Page
<ul style="list-style-type: none"> <li>Added <i>ESD Ratings</i> table, <i>Feature Description</i> section, <i>Device Functional Modes</i>, <i>Application and Implementation</i> section, <i>Power Supply Recommendations</i> section, <i>Layout</i> section, <i>Device and Documentation Support</i> section, and <i>Mechanical, Packaging, and Orderable Information</i> section .....</li> </ul>	<b>1</b>

## 5 Pin Configuration and Functions

**OPA227, OPA228: P or D Package  
8-Pin PDIP or 8-Pin SOIC  
Top View**

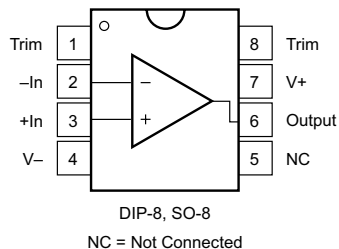

**OPA2227, OPA2228: P or D Package  
8-Pin PDIP or 8-Pin SOIC  
Top View**

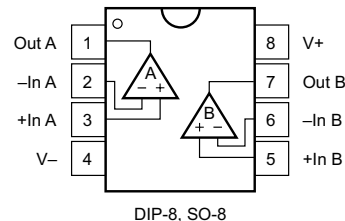

**OPA4227, OPA4228: N or D Package  
14-Pin PDIP or 14-Pin-SOIC  
Top View**

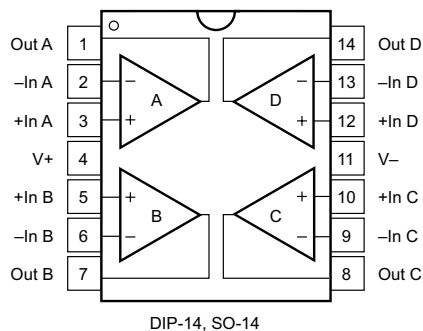

### Pin Functions: OPA227 and OPA228

PIN		I/O	DESCRIPTION
NAME	PDIP, SOIC		
Offset Trim	1	I	Input offset voltage trim (leave floating if not used)
-In	2	I	Inverting input
+In	3	I	Noninverting input
V-	4	—	Negative (lowest) power supply
NC	5	—	No internal connection (can be left floating)
Output	6	O	Output
V+	7	—	Positive (highest) power supply
Offset Trim	8	—	Input offset voltage trim (leave floating if not used)

### Pin Functions: OPA2227 and OPA2228

PIN		I/O	DESCRIPTION
NAME	PDIP, SOIC		
Out A	1	O	Output channel A
-In A	2	I	Inverting input channel A
+In A	3	I	Noninverting input channel A
V-	4	—	Negative (lowest) power supply
+In B	5	I	Noninverting input channel B
-In B	6	I	Inverting input channel B
Out B	7	O	Output channel B
V+	8	—	Positive (highest) power supply

**Pin Functions: OPA4227 and OPA4228**

PIN		I/O	DESCRIPTION
NAME	PDIP, SOIC		
Out A	1	O	Output channel A
-In A	2	I	Inverting input channel A
+In A	3	I	Noninverting input channel A
V+	4	—	Positive (highest) power supply
+In B	5	I	Noninverting input channel B
-In B	6	I	Inverting input channel B
Out B	7	O	Output channel B
Out C	8	O	Output channel C
-In C	9	I	Inverting input channel C
+In C	10	I	Noninverting input channel C
V-	11	—	Negative (lowest) power supply
+In D	12	I	Noninverting input channel D
-In D	13	I	Inverting input channel D
Out D	14	O	Output channel D

## 6 Specifications

### 6.1 Absolute Maximum Ratings

over operating free-air temperature range (unless otherwise noted) <sup>(1)</sup>

		MIN	MAX	UNIT
Supply voltage, $V_s = (V+) - (V-)$		36		V
Signal input terminals	Voltage	(V-) – 0.7	(V+) +0.7	V
	Current	20		mA
Output short-circuit <sup>(2)</sup>		Continuous		
Operating temperature		–55	125	°C
Junction temperature		150		°C
$T_{stg}$	Storage temperature	–65	150	°C

- (1) Stresses beyond those listed under *Absolute Maximum Ratings* may cause permanent damage to the device. These are stress ratings only, which do not imply functional operation of the device at these or any other conditions beyond those indicated under *Recommended Operating Conditions*. Exposure to absolute-maximum-rated conditions for extended periods may affect device reliability.
- (2) Short-circuit to ground, one amplifier per package

### 6.2 ESD Ratings

		VALUE	UNIT	
$V_{(ESD)}$	Electrostatic discharge	Human-body model (HBM), per ANSI/ESDA/JEDEC JS-001 <sup>(1)</sup>	±2000	V

- (1) JEDEC document JEP155 states that 500-V HBM allows safe manufacturing with a standard ESD control process.

### 6.3 Recommended Operating Conditions

over operating free-air temperature range (unless otherwise noted)

		MIN	NOM	MAX	UNIT
Supply voltage, $V_s = (V+) - (V-)$		±2.5	±15	±18	V
Specified temperature		–40		85	°C

### 6.4 Thermal Information: OPA227U/UA and OPA228U/UA

THERMAL METRIC <sup>(1)</sup>		OPA227U/UA OPA228U/UA	OPA2227U/UA OPA2228U/UA	OPA4227UA OPA4228UA	UNIT
		D (SOIC)	D (SOIC)	D (SOIC)	
		8 PINS	8 PINS	14 PINS	
$R_{\theta JA}$	Junction-to-ambient thermal resistance	110.1	101.9	65	°C/W
$R_{\theta JC(top)}$	Junction-to-case (top) thermal resistance	52.2	46.3	23.1	°C/W
$R_{\theta JB}$	Junction-to-board thermal resistance	52.3	45.5	20.3	°C/W
$\psi_{JT}$	Junction-to-top characterization parameter	10.4	6.6	1.8	°C/W
$\psi_{JB}$	Junction-to-board characterization parameter	51.5	42.8	19.9	°C/W
$R_{\theta JC(bot)}$	Junction-to-case (bottom) thermal resistance	N/A	N/A	N/A	°C/W

- (1) For more information about traditional and new thermal metrics, see the *Semiconductor and IC Package Thermal Metrics* application report, [SPRA953](#).

## 6.5 Thermal Information: OPA227P/PA and OPA228P/PA

THERMAL METRIC <sup>(1)</sup>		OPA227P/PA OPA228P/PA			UNIT
		P (PDIP)	D (SOIC)	N (PDIP)	
		8 PINS	8 PINS	14 PINS	
$R_{\theta JA}$	Junction-to-ambient thermal resistance	48.9	110.1	65.5	°C/W
$R_{\theta JC(top)}$	Junction-to-case (top) thermal resistance	37.7	52.2	20	°C/W
$R_{\theta JB}$	Junction-to-board thermal resistance	26.1	52.3	25.9	°C/W
$\Psi_{JT}$	Junction-to-top characterization parameter	15.1	10.4	1.9	°C/W
$\Psi_{JB}$	Junction-to-board characterization parameter	26	51.5	25.3	°C/W
$R_{\theta JC(bot)}$	Junction-to-case (bottom) thermal resistance	N/A	N/A	N/A	°C/W

(1) For more information about traditional and new thermal metrics, see the *Semiconductor and IC Package Thermal Metrics* application report, [SPRA953](#).

## 6.6 Electrical Characteristics: OPAX227 Series ( $V_S = \pm 5\text{ V}$ to $\pm 15\text{ V}$ )

At  $T_A = 25^\circ\text{C}$ , and  $R_L = 10\text{ k}\Omega$ , unless otherwise noted.

PARAMETER		TEST CONDITIONS	OPA227P, U OPA2227P, U			OPA227PA, UA OPA2227PA, UA OPA4227PA, UA			UNIT
			MIN	TYP	MAX	MIN	TYP	MAX	
<b>OFFSET VOLTAGE</b>									
$V_{OS}$	Input Offset Voltage			$\pm 5$	$\pm 75$		$\pm 10$	$\pm 200$	$\mu\text{V}$
		$T_A = -40^\circ\text{C}$ to $85^\circ\text{C}$			$\pm 100$			$\pm 200$	$\mu\text{V}$
$dV_{OS}/dT$	vs Temperature	$T_A = -40^\circ\text{C}$ to $85^\circ\text{C}$		$\pm 0.1$	$\pm 0.6$		$\pm 0.3$	$\pm 2$	$\mu\text{V}/^\circ\text{C}$
PSRR	vs Power Supply	$V_S = \pm 2.5\text{ V}$ to $\pm 18\text{ V}$		$\pm 0.5$	$\pm 2$		$\pm 0.5$	$\pm 2$	$\mu\text{V}/\text{V}$
		$T_A = -40^\circ\text{C}$ to $85^\circ\text{C}$			$\pm 2$			$\pm 2$	$\mu\text{V}/\text{V}$
	vs Time			0.2			0.2		$\mu\text{V}/\text{mo}$
	Channel Separation (dual, quad)	DC		0.2			0.2		$\mu\text{V}/\text{V}$
		$f = 1\text{ kHz}$ , $R_L = 5\text{ k}\Omega$		110			110		dB
<b>INPUT BIAS CURRENT</b>									
$I_B$	Input Bias Current			$\pm 2.5$	$\pm 10$		$\pm 2.5$	$\pm 10$	nA
		$T_A = -40^\circ\text{C}$ to $85^\circ\text{C}$			$\pm 10$			$\pm 10$	nA
$I_{OS}$	Input Offset Current			$\pm 2.5$	$\pm 10$		$\pm 2.5$	$\pm 10$	nA
		$T_A = -40^\circ\text{C}$ to $85^\circ\text{C}$			$\pm 10$			$\pm 10$	nA
<b>NOISE</b>									
	Input Voltage Noise, $f = 0.1\text{ Hz}$ to $10\text{ Hz}$			90			90		nVp-p
				15			15		nVrms
$e_n$	Input Voltage Noise Density	$f = 10\text{ Hz}$		3.5			3.5		$\text{nV}/\sqrt{\text{Hz}}$
		$f = 100\text{ Hz}$		3			3		$\text{nV}/\sqrt{\text{Hz}}$
		$f = 1\text{ kHz}$		3			3		$\text{nV}/\sqrt{\text{Hz}}$
$i_n$	Current Noise Density	$f = 1\text{ kHz}$		0.4			0.4		$\text{pA}/\sqrt{\text{Hz}}$
<b>INPUT VOLTAGE RANGE</b>									
$V_{CM}$	Common-Mode Voltage Range			$(V_-)+2$	$(V_+)-2$		$(V_-)+2$	$(V_+)-2$	V
CMRR	Common-Mode Rejection	$V_{CM} = (V_-)+2\text{ V}$ to $(V_+)-2\text{ V}$		120	138		120	138	dB
		$T_A = -40^\circ\text{C}$ to $85^\circ\text{C}$		120			120		dB
<b>INPUT IMPEDANCE</b>									
	Differential			$10^7 \parallel 12$			$10^7 \parallel 12$		$\Omega \parallel \text{pF}$
	Common-Mode	$V_{CM} = (V_-)+2\text{ V}$ to $(V_+)-2\text{ V}$		$10^9 \parallel 3$			$10^9 \parallel 3$		$\Omega \parallel \text{pF}$
<b>OPEN-LOOP GAIN</b>									
$A_{OL}$	Open-Loop Voltage Gain	$V_O = (V_-)+2\text{ V}$ to $(V_+)-2\text{ V}$ , $R_L = 10\text{ k}\Omega$		132	160		132	160	dB
		$T_A = -40^\circ\text{C}$ to $85^\circ\text{C}$		132			132		dB
		$V_O = (V_-)+3.5\text{ V}$ to $(V_+)-3.5\text{ V}$ , $R_L = 600\ \Omega$		132	160		132	160	dB
		$T_A = -40^\circ\text{C}$ to $85^\circ\text{C}$		132			132		dB
<b>FREQUENCY RESPONSE</b>									
GBW	Gain Bandwidth Product			8			8		MHz
SR	Slew Rate			2.3			2.3		V/ $\mu\text{s}$
	Settling Time	0.1%	$G = 1$ , $10\text{ V}$ Step, $C_L = 100\text{ pF}$		5		5		$\mu\text{s}$
		0.01%	$G = 1$ , $10\text{ V}$ Step, $C_L = 100\text{ pF}$		5.6		5.6		$\mu\text{s}$
	Overload Recovery Time	$V_{IN} \times G = V_S$		1.3			1.3		$\mu\text{s}$
THD+N	Total Harmonic Distortion + Noise	$f = 1\text{ kHz}$ , $G = 1$ , $V_O = 3.5\text{ Vrms}$		0.00005%			0.00005%		
<b>OUTPUT</b>									
	Voltage Output	$R_L = 10\text{ k}\Omega$		$(V_-)+2$	$(V_+)-2$		$(V_-)+2$	$(V_+)-2$	V
		$R_L = 10\text{ k}\Omega$		$(V_-)+2$	$(V_+)-2$		$(V_-)+2$	$(V_+)-2$	V
		$T_A = -40^\circ\text{C}$ to $85^\circ\text{C}$							
		$R_L = 600\ \Omega$		$(V_-)+3.5$	$(V_+)-3.5$		$(V_-)+3.5$	$(V_+)-3.5$	V
		$R_L = 600\ \Omega$		$(V_-)+3.5$	$(V_+)-3.5$		$(V_-)+3.5$	$(V_+)-3.5$	V
		$T_A = -40^\circ\text{C}$ to $85^\circ\text{C}$							
$I_{SC}$	Short-Circuit Current			$\pm 45$			$\pm 45$		mA
$C_{LOAD}$	Capacitive Load Drive			See <a href="#">Typical Characteristics</a>			See <a href="#">Typical Characteristics</a>		
$Z_O$	Open-loop output impedance	$f = 1\text{ MHz}$		27			27		$\Omega$

### Electrical Characteristics: OPAx227 Series ( $V_S = \pm 5\text{ V to } \pm 15\text{ V}$ ) (continued)

At  $T_A = 25^\circ\text{C}$ , and  $R_L = 10\text{ k}\Omega$ , unless otherwise noted.

PARAMETER	TEST CONDITIONS	OPA227P, U OPA2227P, U			OPA227PA, UA OPA2227PA, UA OPA4227PA, UA			UNIT	
		MIN	TYP	MAX	MIN	TYP	MAX		
<b>POWER SUPPLY</b>									
$V_S$	Specified Voltage Range		$\pm 5$	$\pm 15$		$\pm 5$	$\pm 15$	V	
	Operating Voltage Range		$\pm 2.5$	$\pm 18$		$\pm 2.5$	$\pm 18$	V	
$I_Q$	Quiescent Current (per amplifier)	$I_O = 0$		$\pm 3.7$	$\pm 3.8$		$\pm 3.7$	$\pm 3.8$	mA
		$I_O = 0$			$\pm 4.2$			$\pm 4.2$	mA
		$T_A = -40^\circ\text{C to } 85^\circ\text{C}$							
<b>TEMPERATURE RANGE</b>									
	Specified Range		-40	85		-40	85	$^\circ\text{C}$	
	Operating Range		-55	125		-55	125	$^\circ\text{C}$	
	Storage Range		-65	150		-65	150	$^\circ\text{C}$	
$\theta_{JA}$	Thermal Resistance								
	SO-8 Surface Mount			150			150	$^\circ\text{C/W}$	
	DIP-8			100			100	$^\circ\text{C/W}$	
	DIP-14			80			80	$^\circ\text{C/W}$	
	SO-14 Surface Mount			100			100	$^\circ\text{C/W}$	

### 6.7 Electrical Characteristics: OPAx228 Series ( $V_S = \pm 5\text{ V to } \pm 15\text{ V}$ )

At  $T_A = 25^\circ\text{C}$ , and  $R_L = 10\text{ k}\Omega$ , unless otherwise noted.

PARAMETER	TEST CONDITIONS	OPA228P, U OPA2228P, U			OPA228PA, UA OPA2228PA, UA OPA4228PA, UA			UNIT
		MIN	TYP	MAX	MIN	TYP	MAX	
<b>OFFSET VOLTAGE</b>								
$V_{OS}$	Input Offset Voltage		$\pm 5$	$\pm 75$		$\pm 10$	$\pm 200$	$\mu\text{V}$
		$T_A = -40^\circ\text{C to } 85^\circ\text{C}$		$\pm 100$			$\pm 200$	$\mu\text{V}$
$dV_{OS}/dT$	vs Temperature	$T_A = -40^\circ\text{C to } 85^\circ\text{C}$	$\pm 0.1$	$\pm 0.6$		$\pm 0.3$	$\pm 2$	$\mu\text{V}/^\circ\text{C}$
PSRR	vs Power Supply	$V_S = \pm 2.5\text{ V to } \pm 18\text{ V}$	$\pm 0.5$	$\pm 2$		$\pm 0.5$	$\pm 2$	$\mu\text{V/V}$
		$T_A = -40^\circ\text{C to } 85^\circ\text{C}$		$\pm 2$			$\pm 2$	$\mu\text{V/V}$
	vs Time		0.2			0.2		$\mu\text{V/mo}$
	Channel Separation (dual, quad)	DC	0.2			0.2		$\mu\text{V/V}$
		$f = 1\text{ kHz}, R_L = 5\text{ k}\Omega$	110			110		dB
<b>INPUT BIAS CURRENT</b>								
$I_B$	Input Bias Current		$\pm 2.5$	$\pm 10$		$\pm 2.5$	$\pm 10$	nA
		$T_A = -40^\circ\text{C to } 85^\circ\text{C}$		$\pm 10$			$\pm 10$	nA
$I_{OS}$	Input Offset Current		$\pm 2.5$	$\pm 10$		$\pm 2.5$	$\pm 10$	nA
		$T_A = -40^\circ\text{C to } 85^\circ\text{C}$		$\pm 10$			$\pm 10$	nA
<b>NOISE</b>								
	Input Voltage Noise, $f = 0.1\text{ Hz to } 10\text{ Hz}$		90			90		nVp-p
			15			15		nVrms
$e_n$	Input Voltage Noise Density	$f = 10\text{ Hz}$	3.5			3.5		$\text{nV}/\sqrt{\text{Hz}}$
		$f = 100\text{ Hz}$	3			3		$\text{nV}/\sqrt{\text{Hz}}$
		$f = 1\text{ kHz}$	3			3		$\text{nV}/\sqrt{\text{Hz}}$
$i_n$	Current Noise Density	$f = 1\text{ kHz}$	0.4			0.4		$\text{pA}/\sqrt{\text{Hz}}$
<b>INPUT VOLTAGE RANGE</b>								
$V_{CM}$	Common-Mode Voltage Range		(V-)+2	(V+)-2		(V-)+2	(V+)-2	V
CMRR	Common-Mode Rejection	$V_{CM} = (V-)+2\text{ V to } (V+)-2\text{ V}$	120	138		120	138	dB
		$T_A = -40^\circ\text{C to } 85^\circ\text{C}$	120			120		dB
<b>INPUT IMPEDANCE</b>								
	Differential		$10^7 \parallel 12$			$10^7 \parallel 12$		$\Omega \parallel \text{pF}$
	Common-Mode	$V_{CM} = (V-)+2\text{ V to } (V+)-2\text{ V}$	$10^9 \parallel 3$			$10^9 \parallel 3$		$\Omega \parallel \text{pF}$

**Electrical Characteristics: OPAx228 Series ( $V_S = \pm 5\text{ V}$  to  $\pm 15\text{ V}$ ) (continued)**

At  $T_A = 25^\circ\text{C}$ , and  $R_L = 10\text{ k}\Omega$ , unless otherwise noted.

PARAMETER		TEST CONDITIONS	OPA228P, U OPA2228P, U			OPA228PA, UA OPA2228PA, UA OPA4228PA, UA			UNIT
			MIN	TYP	MAX	MIN	TYP	MAX	
<b>OPEN-LOOP GAIN</b>									
$A_{OL}$	Open-Loop Voltage Gain	$V_O = (V_-)+2\text{ V}$ to $(V_+)-2\text{ V}$ , $R_L = 10\text{ k}\Omega$	132	160		132	160		dB
		$T_A = -40^\circ\text{C}$ to $85^\circ\text{C}$	132			132			dB
		$V_O = (V_-)+3.5\text{ V}$ to $(V_+)-3.5\text{ V}$ , $R_L = 600\ \Omega$	132	160		132	160		dB
		$T_A = -40^\circ\text{C}$ to $85^\circ\text{C}$	132			132			dB
<b>FREQUENCY RESPONSE</b>									
	Minimum Closed-Loop Gain			5		5			V/V
GBW	Gain Bandwidth Product			33		33			MHz
SR	Slew Rate			11		11			V/ $\mu\text{s}$
	Settling Time	0.1%	$G = 5, 10\text{ V Step}, C_L = 100\text{ pF}, C_F = 12\text{ pF}$		1.5		1.5		$\mu\text{s}$
		0.01%	$G = 5, 10\text{ V Step}, C_L = 100\text{ pF}, C_F = 12\text{ pF}$		2		2		$\mu\text{s}$
	Overload Recovery Time	$V_{IN} \times G = V_S$	0.6		0.6		0.6		$\mu\text{s}$
THD+N	Total Harmonic Distortion + Noise	$f = 1\text{ kHz}, G = 5, V_O = 3.5\text{ Vrms}$	0.00005%		0.00005%		0.00005%		
<b>OUTPUT</b>									
	Voltage Output	$R_L = 10\text{ k}\Omega$	$(V_-)+2$	$(V_+)-2$	$(V_-)+2$	$(V_+)-2$	$(V_-)+2$	$(V_+)-2$	V
		$R_L = 10\text{ k}\Omega$	$(V_-)+2$	$(V_+)-2$	$(V_-)+2$	$(V_+)-2$	$(V_-)+2$	$(V_+)-2$	V
		$T_A = -40^\circ\text{C}$ to $85^\circ\text{C}$							
		$R_L = 600\ \Omega$	$(V_-)+3.5$	$(V_+)-3.5$	$(V_-)+3.5$	$(V_+)-3.5$	$(V_-)+3.5$	$(V_+)-3.5$	V
		$R_L = 600\ \Omega$	$(V_-)+3.5$	$(V_+)-3.5$	$(V_-)+3.5$	$(V_+)-3.5$	$(V_-)+3.5$	$(V_+)-3.5$	V
		$T_A = -40^\circ\text{C}$ to $85^\circ\text{C}$							
$I_{SC}$	Short-Circuit Current		$\pm 45$		$\pm 45$		$\pm 45$		mA
$C_{LOAD}$	Capacitive Load Drive		See <i>Typical Characteristics</i>		See <i>Typical Characteristics</i>		See <i>Typical Characteristics</i>		
$Z_O$	Open-loop output impedance	$f = 1\text{ MHz}$	27		27		27		$\Omega$
<b>POWER SUPPLY</b>									
$V_S$	Specified Voltage Range		$\pm 5$	$\pm 15$	$\pm 5$	$\pm 15$	$\pm 5$	$\pm 15$	V
	Operating Voltage Range		$\pm 2.5$	$\pm 18$	$\pm 2.5$	$\pm 18$	$\pm 2.5$	$\pm 18$	V
$I_Q$	Quiescent Current (per amplifier)	$I_O = 0$	$\pm 3.7$		$\pm 3.8$		$\pm 3.7$		mA
		$I_O = 0$	$\pm 4.2$		$\pm 4.2$		$\pm 4.2$		mA
		$T_A = -40^\circ\text{C}$ to $85^\circ\text{C}$							
<b>TEMPERATURE RANGE</b>									
	Specified Range		-40	85	-40	85	-40	85	$^\circ\text{C}$
	Operating Range		-55	125	-55	125	-55	125	$^\circ\text{C}$
	Storage Range		-65	150	-65	150	-65	150	$^\circ\text{C}$
$\theta_{JA}$	Thermal Resistance								
	SO-8 Surface Mount		150		150		150		$^\circ\text{C/W}$
	DIP-8		100		100		100		$^\circ\text{C/W}$
	DIP-14		80		80		80		$^\circ\text{C/W}$
	SO-14 Surface Mount		100		100		100		$^\circ\text{C/W}$

## 6.8 Typical Characteristics

At  $T_A = 25^\circ\text{C}$ ,  $R_L = 10\text{ k}\Omega$ , and  $V_S = \pm 15\text{ V}$ , unless otherwise noted.

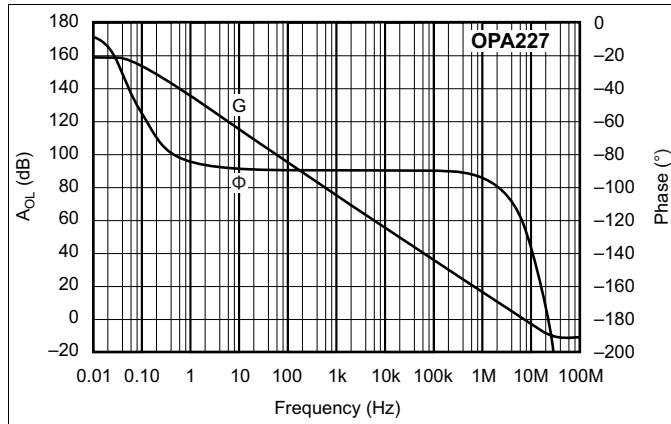

Figure 1. Open-Loop Gain and Phase vs Frequency

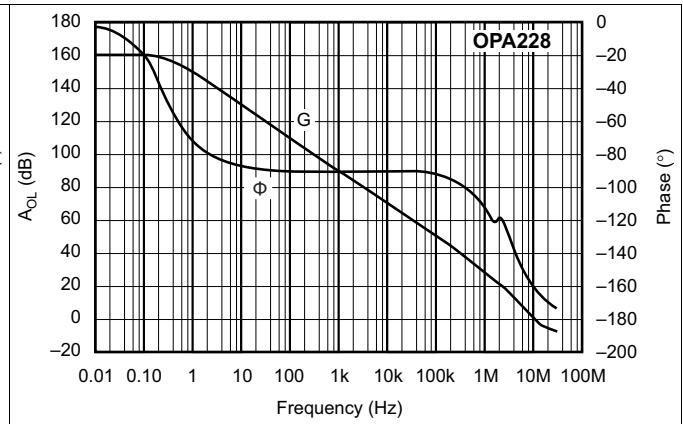

Figure 2. Open-Loop Gain and Phase vs Frequency

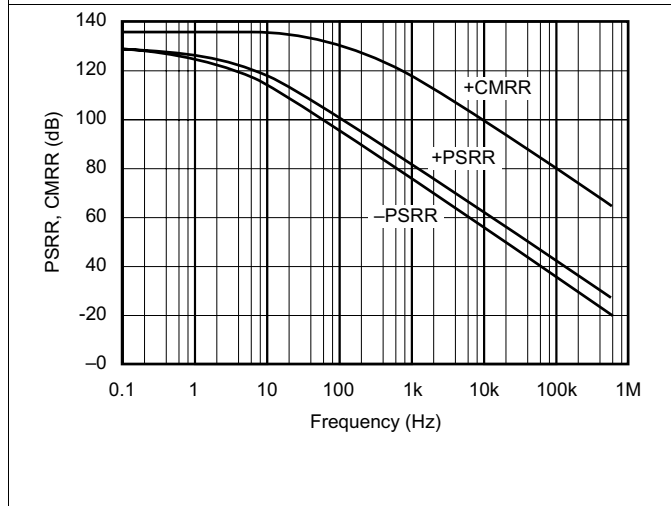

Figure 3. Power Supply and Common-Mode Rejection Ratio vs Frequency

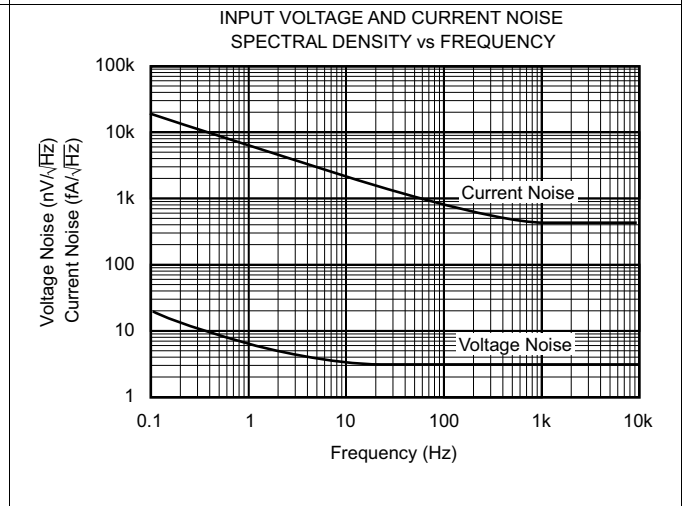

Figure 4. Input Voltage and Current Noise Spectral Density vs Frequency

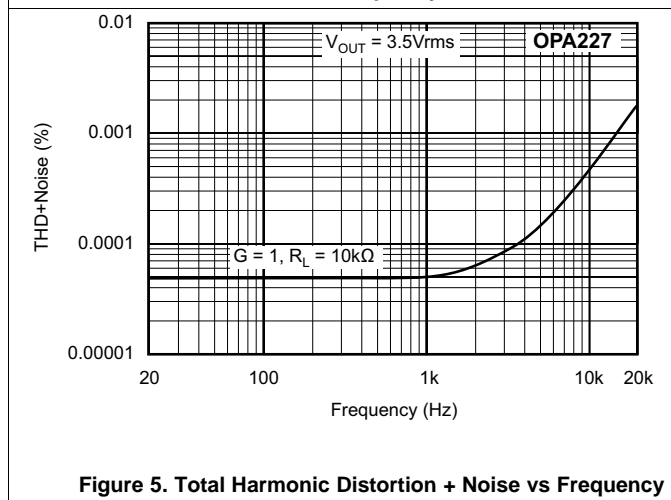

Figure 5. Total Harmonic Distortion + Noise vs Frequency

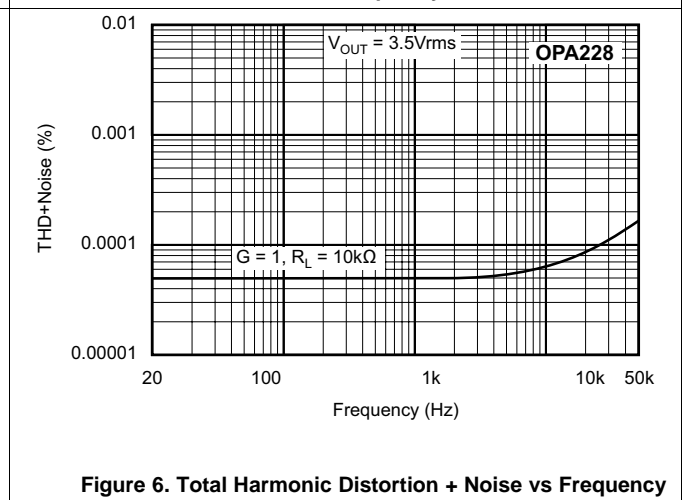
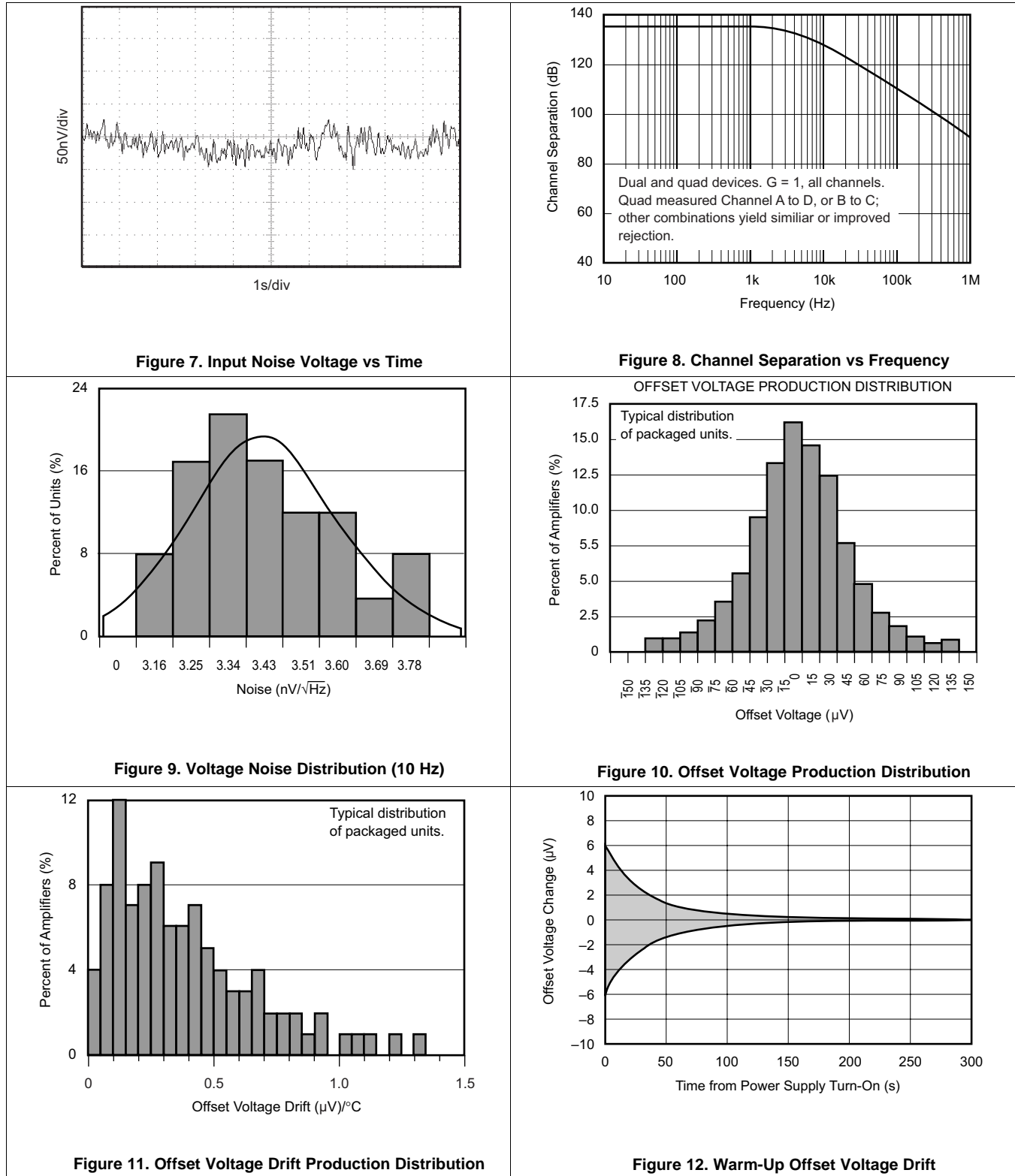

Figure 6. Total Harmonic Distortion + Noise vs Frequency

### Typical Characteristics (continued)

At  $T_A = 25^\circ\text{C}$ ,  $R_L = 10\text{ k}\Omega$ , and  $V_S = \pm 15\text{ V}$ , unless otherwise noted.



## Typical Characteristics (continued)

At  $T_A = 25^\circ\text{C}$ ,  $R_L = 10\text{ k}\Omega$ , and  $V_S = \pm 15\text{ V}$ , unless otherwise noted.

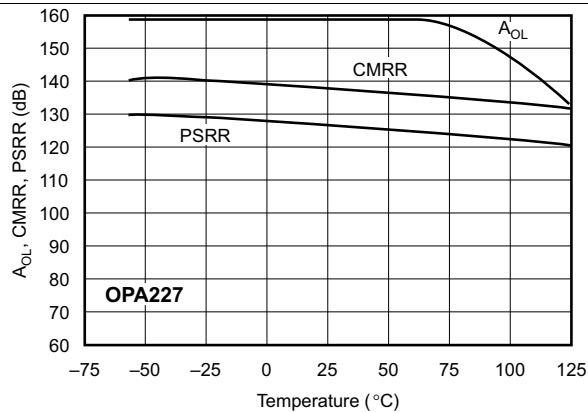

Figure 13.  $A_{OL}$ , CMRR, PSRR vs Temperature

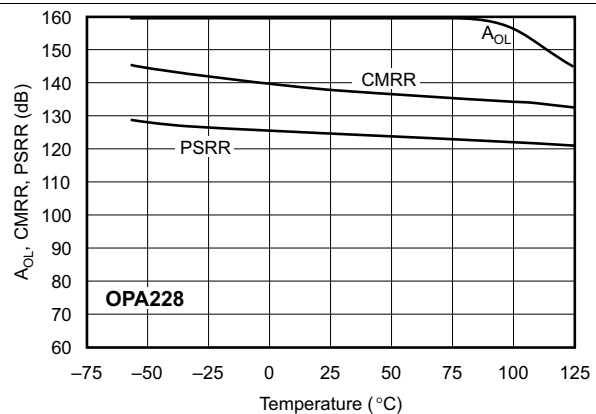

Figure 14.  $A_{OL}$ , CMRR, PSRR vs Temperature

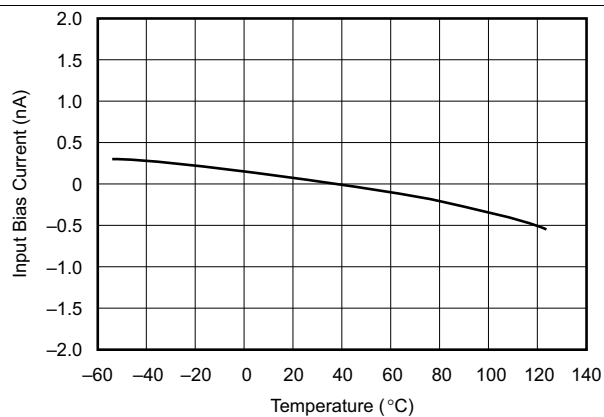

Figure 15. Input Bias Current vs Temperature

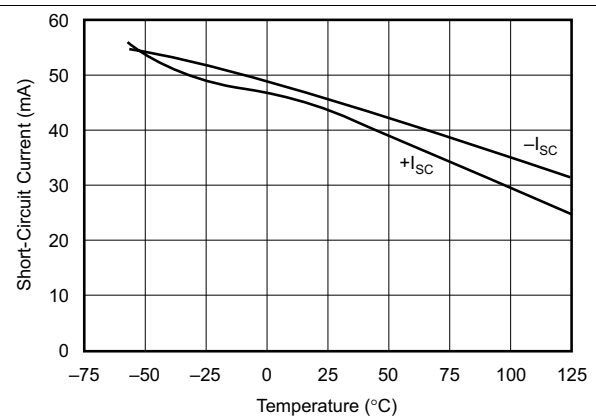

Figure 16. Short-Circuit Current vs Temperature

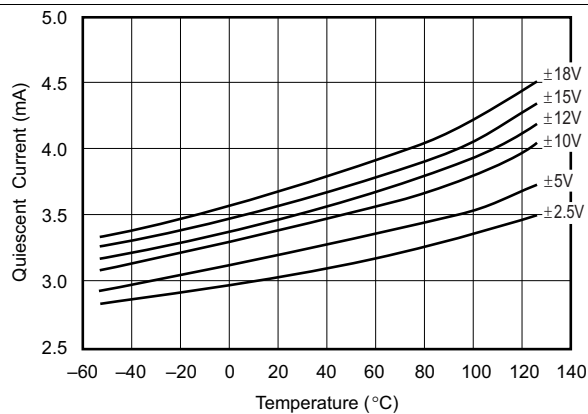

Figure 17. Quiescent Current vs Temperature

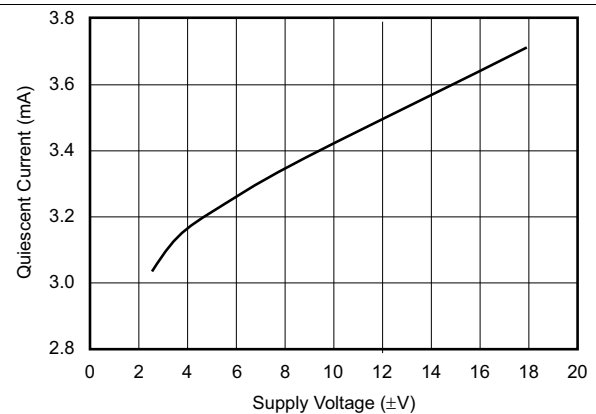

Figure 18. Quiescent Current vs Supply Voltage

Typical Characteristics (continued)

At  $T_A = 25^\circ\text{C}$ ,  $R_L = 10\text{ k}\Omega$ , and  $V_S = \pm 15\text{ V}$ , unless otherwise noted.

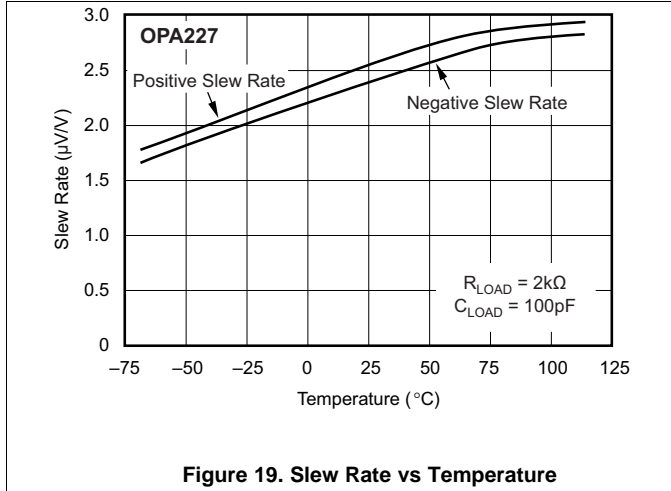

Figure 19. Slew Rate vs Temperature

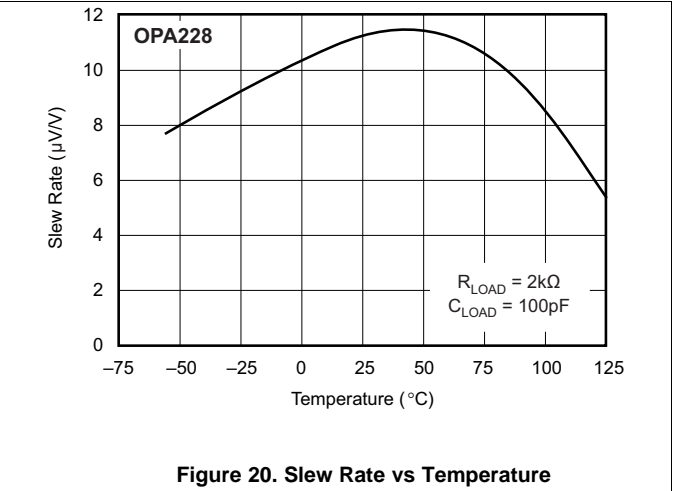

Figure 20. Slew Rate vs Temperature

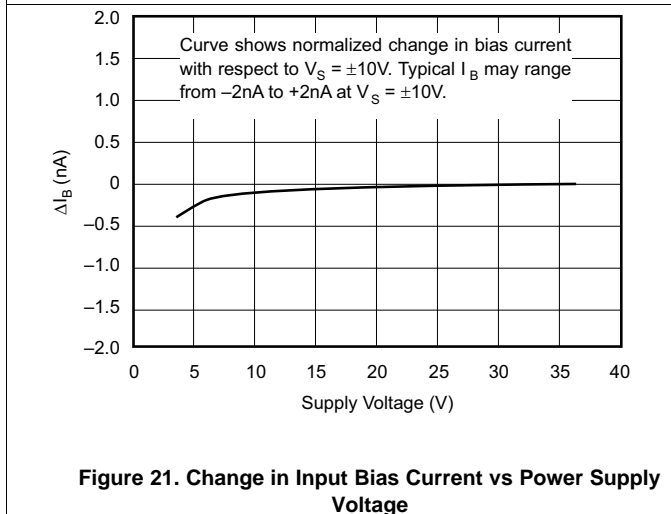

Figure 21. Change in Input Bias Current vs Power Supply Voltage

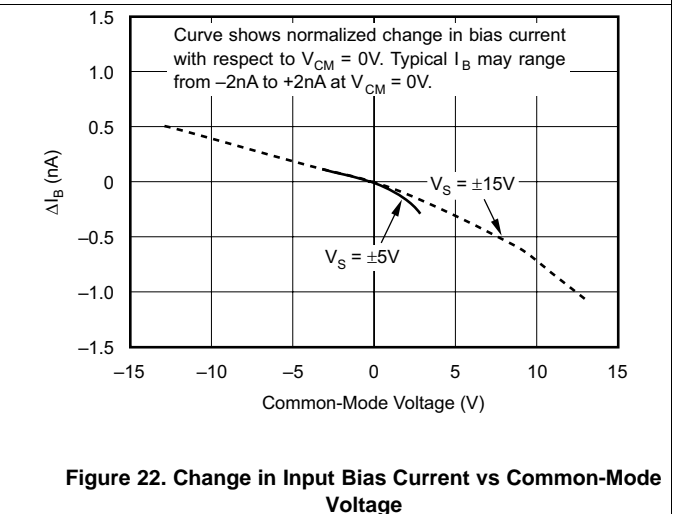

Figure 22. Change in Input Bias Current vs Common-Mode Voltage

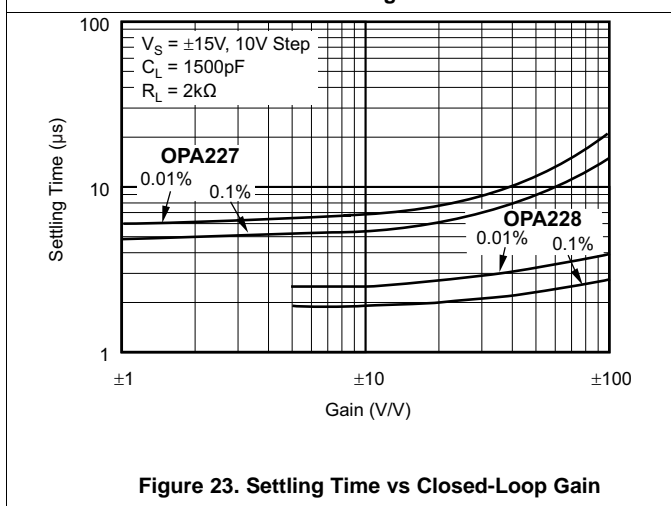

Figure 23. Settling Time vs Closed-Loop Gain

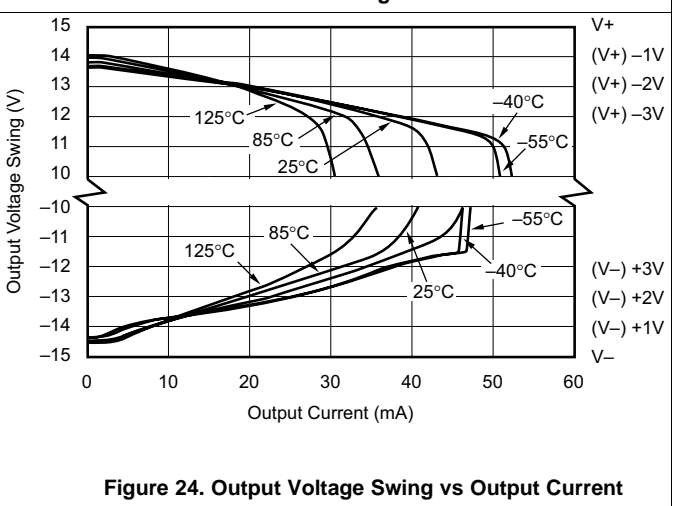

Figure 24. Output Voltage Swing vs Output Current

## Typical Characteristics (continued)

At  $T_A = 25^\circ\text{C}$ ,  $R_L = 10\text{ k}\Omega$ , and  $V_S = \pm 15\text{ V}$ , unless otherwise noted.



Figure 25. Maximum Output Voltage vs Frequency



Figure 26. Small-Signal Overshoot vs Load Capacitance

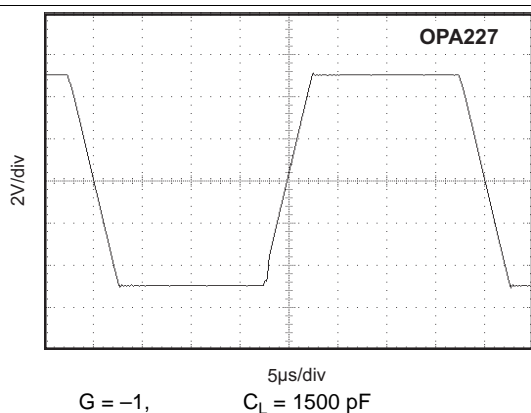

Figure 27. Large-Signal Step Response

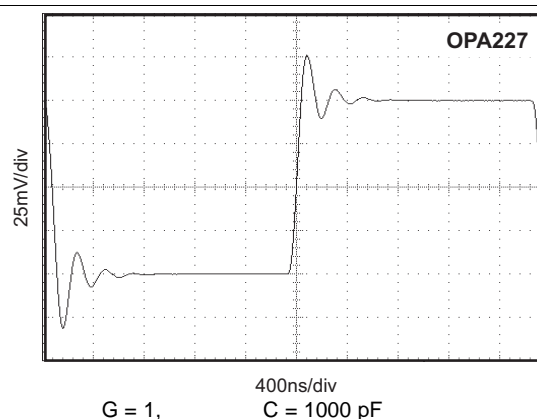

Figure 28. Small-Signal Step Response

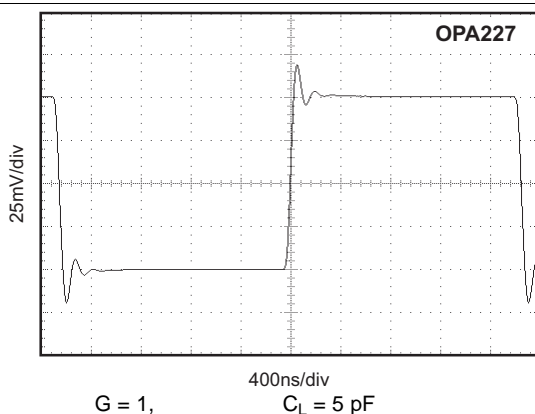

Figure 29. Small-Signal Step Response

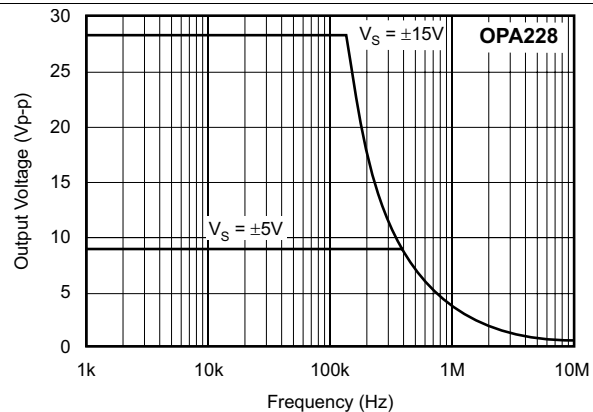

Figure 30. Maximum Output Voltage vs Frequency

Typical Characteristics (continued)

At  $T_A = 25^\circ\text{C}$ ,  $R_L = 10\text{ k}\Omega$ , and  $V_S = \pm 15\text{ V}$ , unless otherwise noted.



Figure 31. Small-Signal Overshoot vs Load Capacitance

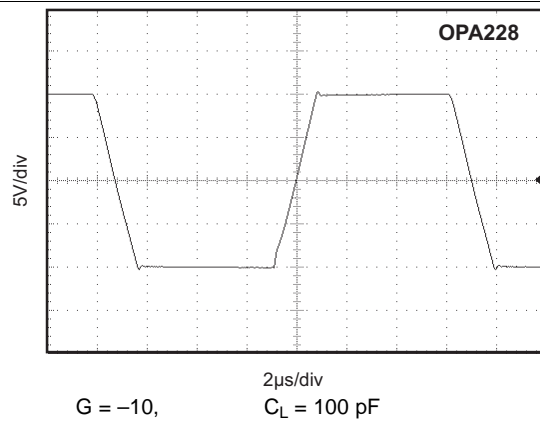

Figure 32. Large-Signal Step Response

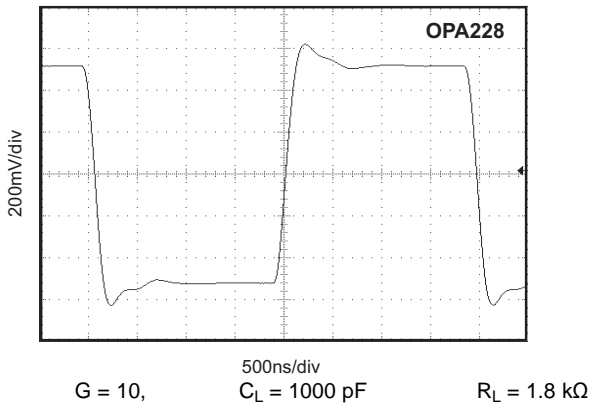

Figure 33. Small-Signal Step Response

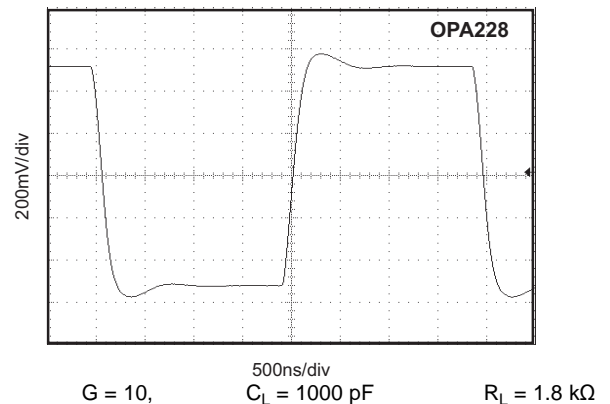

Figure 34. Small-Signal Step Response

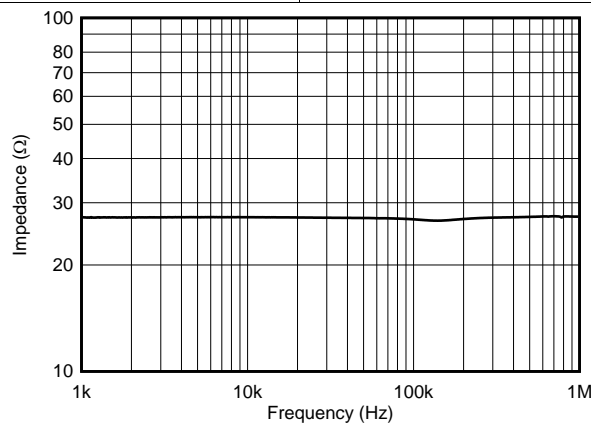

Figure 35. Open-loop Output Impedance

## 7 Detailed Description

### 7.1 Overview

The OPAX22x series operational amplifiers combine low noise and wide bandwidth with high precision to make them the ideal choice for applications requiring both AC and precision DC performance. The OPAX227 is unity-gain stable and features high slew rate (2.3 V/ $\mu$ s) and wide bandwidth (8 MHz). The OPAX228 is optimized for closed-loop gains of 5 or greater, and offers higher speed with a slew rate of 10 V/ $\mu$ s and a bandwidth of 33 MHz.

### 7.2 Functional Block Diagram

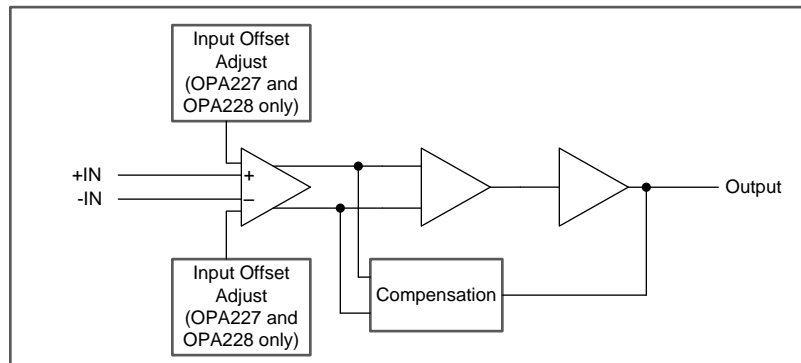

### 7.3 Feature Description

The OPAX22x series are unity-gain stable and free from unexpected output phase reversal, making it easy to use in a wide range of applications. Applications with noisy or high-impedance power supplies may require decoupling capacitors close to the device pins. In most cases 0.1- $\mu$ F capacitors are adequate.

#### 7.3.1 Offset Voltage and Drift

The OPAX22x series have very low offset voltage and drift. To achieve highest DC precision, circuit layout and mechanical conditions should be optimized. Connections of dissimilar metals can generate thermal potentials at the operational amplifier inputs, which can degrade the offset voltage and drift. These thermocouple effects can exceed the inherent drift of the amplifier and ultimately degrade its performance. The thermal potentials can be made to cancel by assuring that they are equal at both input terminals. In addition:

- Keep thermal mass of the connections made to the two input terminals similar.
- Locate heat sources as far as possible from the critical input circuitry.
- Shield operational amplifier and input circuitry from air currents such as those created by cooling fans.

#### 7.3.2 Operating Voltage

The OPAX22x series of operational amplifiers operate from  $\pm 2.5$  V to  $\pm 18$  V supplies with excellent performance. Unlike most operational amplifiers that are specified at only one supply voltage, the OPA227 series is specified for real-world applications; a single set of specifications applies over the  $\pm 5$ -V to  $\pm 15$ -V supply range. Specifications are assured for applications from  $\pm 5$ -V to  $\pm 15$ -V power supplies. Some applications do not require equal positive and negative output voltage swing. Power supply voltages do not need to be equal. The OPAX22x series can operate with as little as 5 V between the supplies and with up to 36 V between the supplies. For example, the positive supply could be set to 25 V with the negative supply at  $-5$  V or vice-versa. In addition, key parameters are assured over the specified temperature range,  $-40^{\circ}\text{C}$  to  $85^{\circ}\text{C}$ . Parameters which vary significantly with operating voltage or temperature are shown in the [Typical Characteristics](#).

## Feature Description (continued)

### 7.3.3 Offset Voltage Adjustment

The OPAx22x series are laser-trimmed for very low offset and drift so most applications will not require external adjustment. However, the OPA227 and OPA228 (single versions) provide offset voltage trim connections on pins 1 and 8. Offset voltage can be adjusted by connecting a potentiometer as shown in Figure 36. This adjustment should be used only to null the offset of the operational amplifier. This adjustment should not be used to compensate for offsets created elsewhere in the system because this can introduce additional temperature drift.

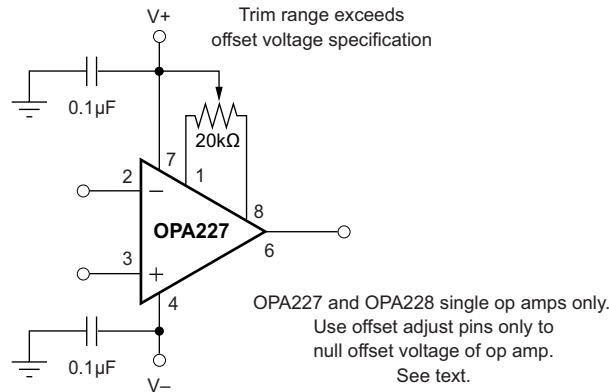

Figure 36. OPA227 Offset Voltage Trim Circuit

### 7.3.4 Input Protection

Back-to-back diodes (see Figure 37) are used for input protection on the OPAx22x. Exceeding the turnon threshold of these diodes, as in a pulse condition, can cause current to flow through the input protection diodes due to the amplifier's finite slew rate. Without external current limiting resistors, the input devices can be destroyed. Sources of high-input current can cause subtle damage to the amplifier. Although the unit may still be functional, important parameters such as input offset voltage, drift, and noise may shift.



Figure 37. Pulsed Operation

When using the OPA227 as a unity-gain buffer (follower), the input current should be limited to 20 mA. This can be accomplished by inserting a feedback resistor or a resistor in series with the source. Use Equation 1 to calculate sufficient resistor size.

$$R_X = V_S / 20\text{mA} - R_{\text{SOURCE}}$$

where

- $R_X$  is either in series with the source or inserted in the feedback path. (1)

For example, for a 10-V pulse ( $V_S = 10\text{ V}$ ), total loop resistance must be 500  $\Omega$ . If the source impedance is large enough to sufficiently limit the current on its own, no additional resistors are needed. The size of any external resistors must be carefully chosen because they will increase noise. See the [Noise Performance](#) section of this data sheet for further information on noise calculation. Figure 37 shows an example implementing a current limiting feedback resistor.

## Feature Description (continued)

### 7.3.5 Input Bias Current Cancellation

The input bias current of the OPAx22x series is internally compensated with an equal and opposite cancellation current. The resulting input bias current is the difference between with input bias current and the cancellation current. The residual input bias current can be positive or negative.

When the bias current is cancelled in this manner, the input bias current and input offset current are approximately equal. A resistor added to cancel the effect of the input bias current (as shown in Figure 38) may actually increase offset and noise and is therefore not recommended.

#### Conventional Op Amp Configuration

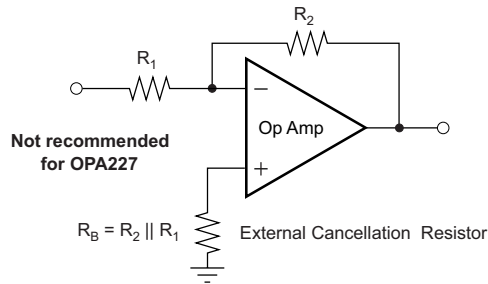

#### Recommended OPA227 Configuration

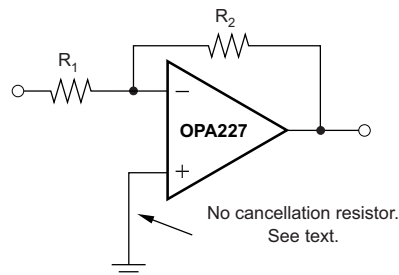
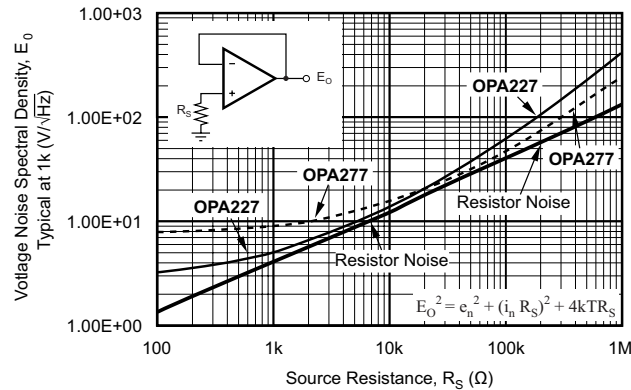

Figure 38. Input Bias Current Cancellation

### 7.3.6 Noise Performance

Figure 39 shows total circuit noise for varying source impedances with the operational amplifier in a unity-gain configuration (no feedback resistor network, therefore no additional noise contributions). Two different operational amplifiers are shown with total circuit noise calculated. The OPA227 has very low voltage noise, making it ideal for low source impedances (less than 20 kΩ). A similar precision operational amplifier, the OPA277, has somewhat higher voltage noise but lower current noise. It provides excellent noise performance at moderate source impedance (10 kΩ to 100 kΩ). Above 100 kΩ, a FET-input operational amplifier such as the OPA132 (very low current noise) may provide improved performance. Use the equation in Figure 39 for calculating the total circuit noise.  $e_n$  = voltage noise,  $i_n$  = current noise,  $R_S$  = source impedance,  $k$  = Boltzmann's constant =  $1.38 \times 10^{-23}$  J/K and  $T$  is temperature in K. For more details on calculating noise, see [Basic Noise Calculations](#).

## Feature Description (continued)



**Figure 39. Noise Performance of the OPA227 in Unity-Gain Buffer Configuration**

### 7.3.7 Basic Noise Calculations

Design of low noise operational amplifier circuits requires careful consideration of a variety of possible noise contributors: noise from the signal source, noise generated in the operational amplifier, and noise from the feedback network resistors. The total noise of the circuit is the root-sum-square combination of all noise components.

The resistive portion of the source impedance produces thermal noise proportional to the square root of the resistance. This function is shown plotted in [Figure 39](#). Because the source impedance is usually fixed, select the operational amplifier and the feedback resistors to minimize their contribution to the total noise.

[Figure 39](#) shows total noise for varying source impedances with the operational amplifier in a unity-gain configuration (no feedback resistor network and therefore no additional noise contributions). The operational amplifier itself contributes both a voltage noise component and a current noise component. The voltage noise is commonly modeled as a time-varying component of the offset voltage. The current noise is modeled as the time-varying component of the input bias current and reacts with the source resistance to create a voltage component of noise. Consequently, the lowest noise operational amplifier for a given application depends on the source impedance. For low source impedance, current noise is negligible and voltage noise generally dominates. For high source impedance, current noise may dominate.

[Figure 40](#) shows both inverting and noninverting operational amplifier circuit configurations with gain. In circuit configurations with gain, the feedback network resistors also contribute noise. The current noise of the operational amplifier reacts with the feedback resistors to create additional noise components. The feedback resistor values can generally be chosen to make these noise sources negligible. The equations for total noise are shown in the following images for both configurations.

## Feature Description (continued)

### Noise in Noninverting Gain Configuration

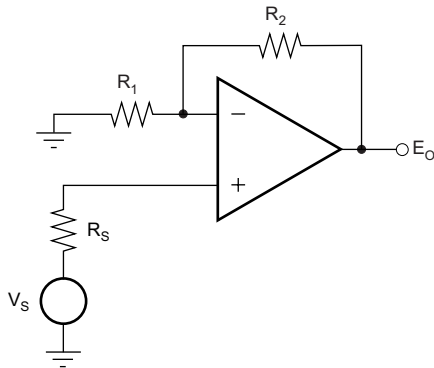

Noise at the output:

$$E_O^2 = \left(1 + \frac{R_2}{R_1}\right)^2 e_n^2 + e_1^2 + e_2^2 + (i_n R_2)^2 + e_s^2 + (i_n R_s)^2 \left(1 + \frac{R_2}{R_1}\right)^2$$

Where  $e_s = \sqrt{4kTR_s} \cdot \left(1 + \frac{R_2}{R_1}\right)$  = thermal noise of  $R_s$

$$e_1 = \sqrt{4kTR_1} \cdot \left(\frac{R_2}{R_1}\right) = \text{thermal noise of } R_1$$

$$e_2 = \sqrt{4kTR_2} = \text{thermal noise of } R_2$$

### Noise in Inverting Gain Configuration

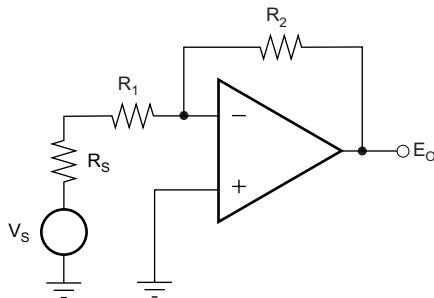

Noise at the output:

$$E_O^2 = \left(1 + \frac{R_2}{R_1 + R_s}\right)^2 e_n^2 + e_1^2 + e_2^2 + (i_n R_2)^2 + e_s^2$$

Where  $e_s = \sqrt{4kTR_s} \cdot \left(\frac{R_2}{R_1 + R_s}\right)$  = thermal noise of  $R_s$

$$e_1 = \sqrt{4kTR_1} \cdot \left(\frac{R_2}{R_1 + R_s}\right) = \text{thermal noise of } R_1$$

$$e_2 = \sqrt{4kTR_2} = \text{thermal noise of } R_2$$

For the OPA227 and OPA228 series op amps at 1kHz,  $e_n = 3\text{nV}/\sqrt{\text{Hz}}$  and  $i_n = 0.4\text{pA}/\sqrt{\text{Hz}}$ .

**Figure 40. Noise Calculation in Gain Configurations**

## Feature Description (continued)



**Figure 41. 0.1 Hz to 10 Hz Bandpass Filter Used to Test Wideband Noise of the OPAx22x Series**

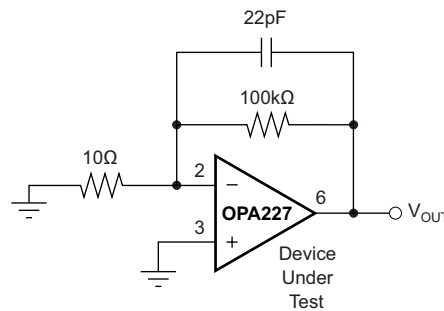

**Figure 42. Noise Test Circuit**

Figure 41 shows the 0.1 Hz 10 Hz bandpass filter used to test the noise of the OPA227 and OPA228. The filter circuit was designed using Texas Instruments' FilterPro software (available at [www.ti.com](http://www.ti.com)). Figure 42 shows the configuration of the OPA227 and OPA228 for noise testing.

### 7.3.8 EMI Rejection Ratio (EMIRR)

The electromagnetic interference (EMI) rejection ratio, or EMIRR, describes the EMI immunity of operational amplifiers. An adverse effect that is common to many operational amplifiers is a change in the offset voltage as a result of RF signal rectification. An operational amplifier that is more efficient at rejecting this change in offset as a result of EMI has a higher EMIRR and is quantified by a decibel value. Measuring EMIRR can be performed in many ways, but this section provides the EMIRR IN+, which specifically describes the EMIRR performance when the RF signal is applied to the noninverting input pin of the operational amplifier. In general, only the noninverting input is tested for EMIRR for the following three reasons:

1. Operational amplifier input pins are known to be the most sensitive to EMI, and typically rectify RF signals better than the supply or output pins.
2. The noninverting and inverting operational amplifier inputs have symmetrical physical layouts and exhibit nearly matching EMIRR performance.
3. EMIRR is easier to measure on noninverting pins than on other pins because the noninverting input terminal can be isolated on a printed-circuit-board (PCB). This isolation allows the RF signal to be applied directly to the noninverting input terminal with no complex interactions from other components or connecting PCB traces.

## Feature Description (continued)

A more formal discussion of the EMIRR IN+ definition and test method is provided in application report [SBOA128](#), EMI Rejection Ratio of Operational Amplifiers, available for download at [www.ti.com](http://www.ti.com). The EMIRR IN+ of the OPA227 is plotted versus frequency as shown in [Figure 43](#).

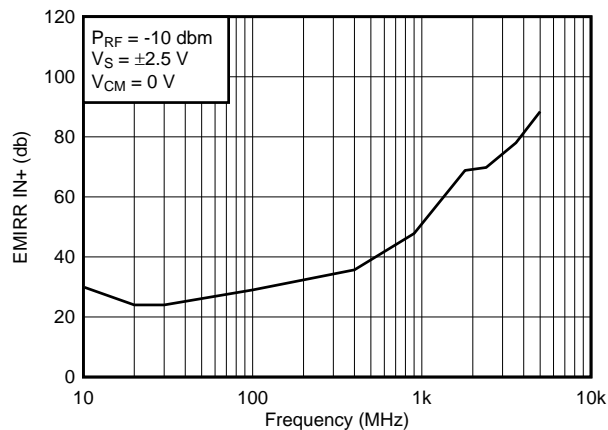

**Figure 43. OPA227 EMIRR IN+ vs Frequency**

If available, any dual and quad operational amplifier device versions have nearly similar EMIRR IN+ performance. The OPAx227 unity-gain bandwidth is 8 MHz. EMIRR performance below this frequency denotes interfering signals that fall within the operational amplifier bandwidth.

[Table 1](#) shows the EMIRR IN+ values for the OPA227 at particular frequencies commonly encountered in real-world applications. Applications listed in [Table 1](#) may be centered on or operated near the particular frequency shown. This information may be of special interest to designers working with these types of applications, or working in other fields likely to encounter RF interference from broad sources, such as the industrial, scientific, and medical (ISM) radio band.

**Table 1. OPAx227 EMIRR IN+ for Frequencies of Interest**

FREQUENCY	APPLICATION/ALLOCATION	EMIRR IN+
400 MHz	Mobile radio, mobile satellite/space operation, weather, radar, UHF	35.7 dB
900 MHz	GSM, radio com/nav./GPS (to 1.6 GHz), ISM, aeronautical mobile, UHF	47.8 dB
1.8 GHz	GSM, mobile personal comm. broadband, satellite, L-band	68.8 dB
2.4 GHz	802.11b/g/n, Bluetooth™, mobile personal comm., ISM, amateur radio/satellite, S-band	69.8 dB
3.6 GHz	Radiolocation, aero comm./nav., satellite, mobile, S-band	78 dB
5 GHz	802.11a/n, aero comm./nav., mobile comm., space/satellite operation, C-band	88.4 dB

### 7.3.8.1 EMIRR IN+ Test Configuration

[Figure 44](#) shows the circuit configuration for testing the EMIRR IN+. An RF source is connected to the operational amplifier noninverting input terminal using a transmission line. The operational amplifier is configured in a unity gain buffer topology with the output connected to a low-pass filter (LPF) and a digital multimeter (DMM). A large impedance mismatch at the operational amplifier input causes a voltage reflection; however, this effect is characterized and accounted for when determining the EMIRR IN+. The resulting DC offset voltage is sampled and measured by the multimeter. The LPF isolates the multimeter from residual RF signals that may interfere with multimeter accuracy. Refer to [SBOA128](#) for more details.

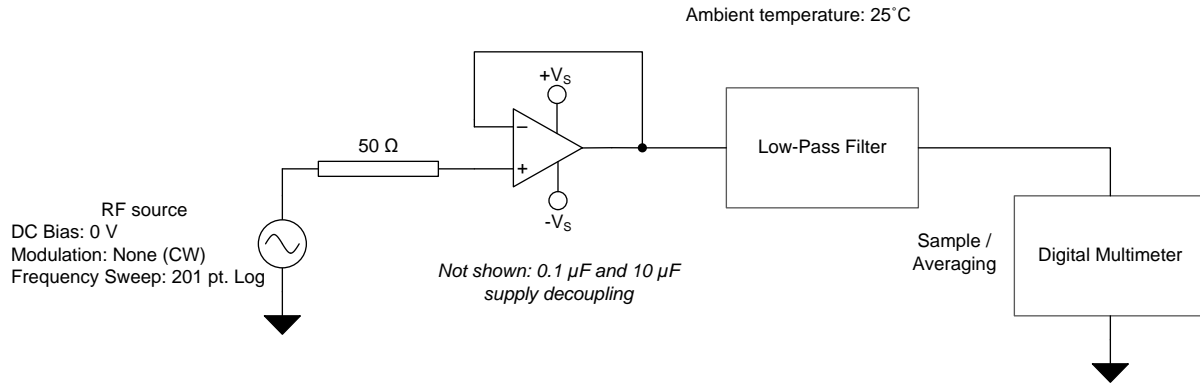

**Figure 44. EMIRR IN+ Test Configuration Schematic**

## 7.4 Device Functional Modes

The OPAx22x has a single functional mode and are operational when the power-supply voltage is greater than 5 V ( $\pm 2.5$  V). The maximum power supply voltage for the OPAx22x is 36 V ( $\pm 18$  V).

## 8 Application and Implementation

### NOTE

Information in the following applications sections is not part of the TI component specification, and TI does not warrant its accuracy or completeness. TI's customers are responsible for determining suitability of components for their purposes. Customers should validate and test their design implementation to confirm system functionality.

### 8.1 Application Information

The OPAx22x series are precision operational amplifiers with very low noise. The OPAx227 series is unity-gain stable with a slew rate of 2.3 V/ $\mu$ s and 8 MHz bandwidth. The OPAx228 series is optimized for higher-speed applications with gains of 5 or greater, featuring a slew rate of 10 V/ $\mu$ s and 33-MHz bandwidth. Applications with noisy or high impedance power supplies may require decoupling capacitors close to the device pins. In most cases, 0.1- $\mu$ F capacitors are adequate.

#### 8.1.1 Three-Pole, 20 kHz Low Pass, 0.5-dB Chebyshev Filter

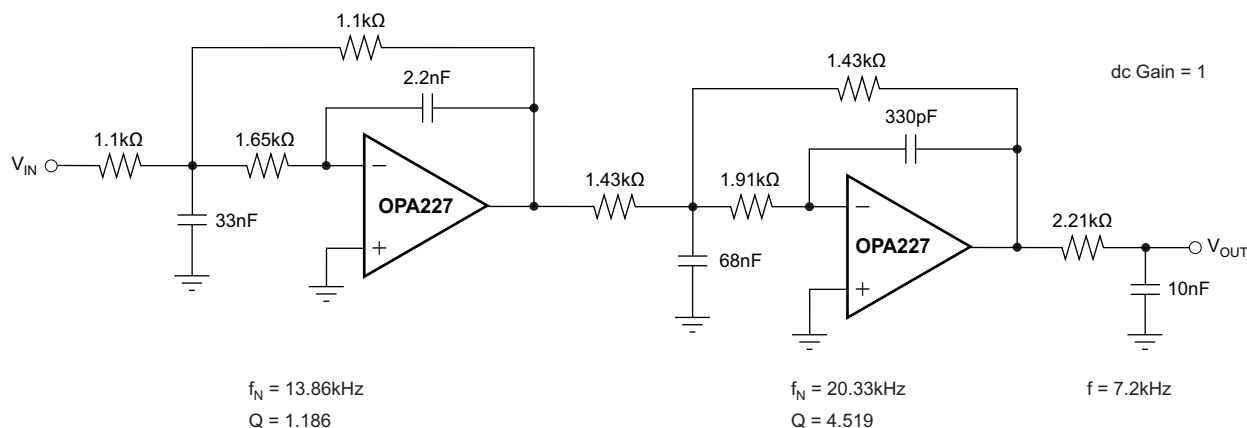

Figure 45. Three-Pole, 20 kHz Low Pass, 0.5-dB Chebyshev Filter

#### 8.1.2 Long-Wavelength Infrared Detector Amplifier

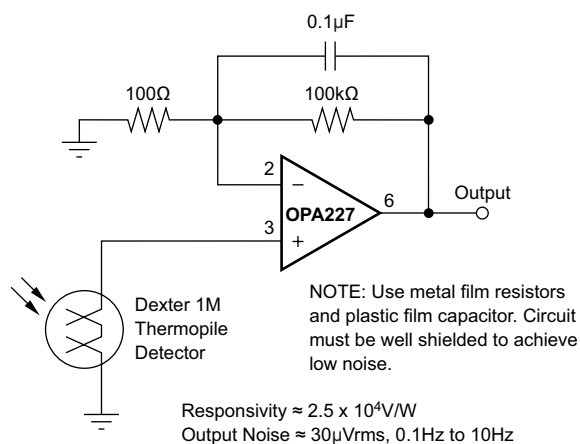

Figure 46. Long-Wavelength Infrared Detector Amplifier

## Application Information (continued)

### 8.1.3 High Performance Synchronous Demodulator

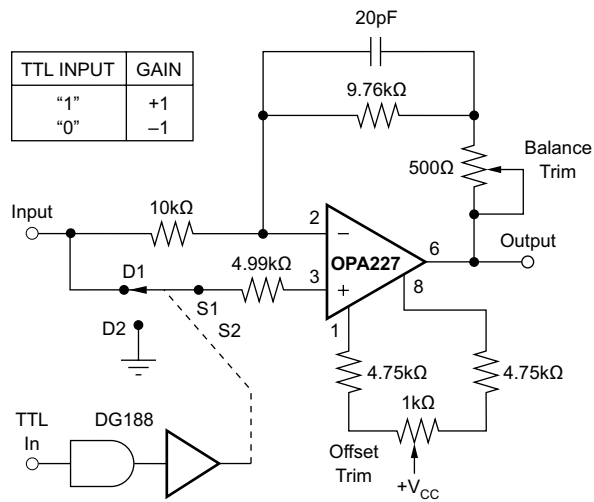

Figure 47. High Performance Synchronous Demodulator

### 8.1.4 Headphone Amplifier

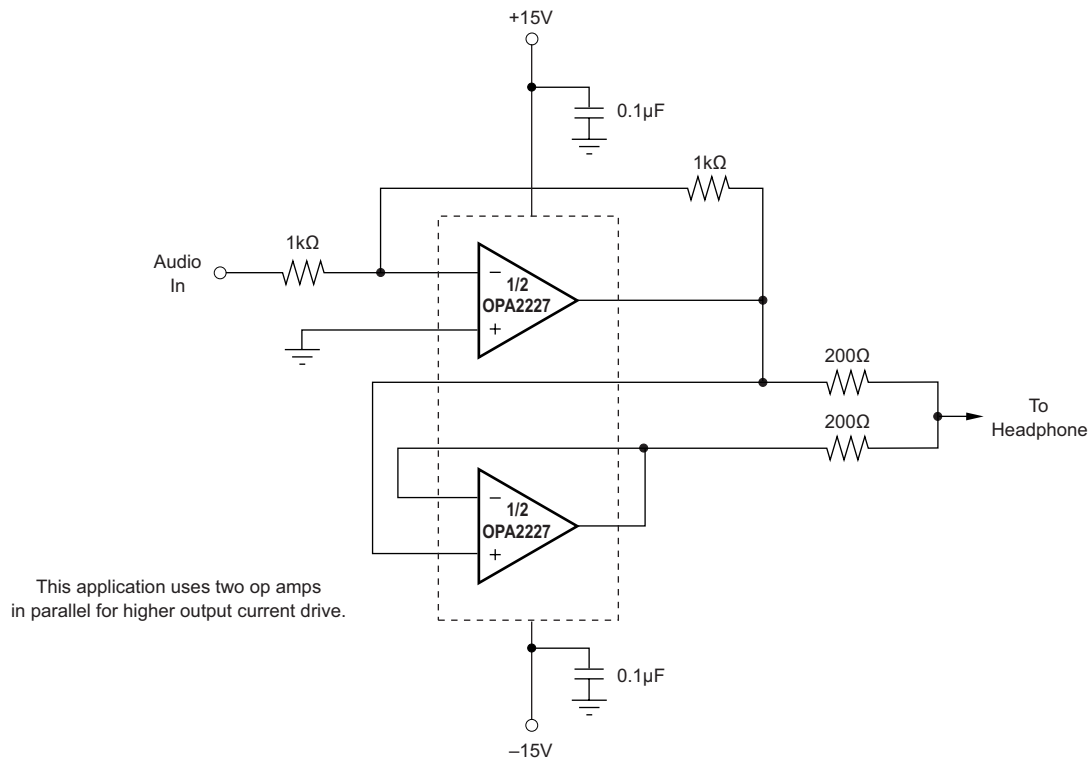

Figure 48. Headphone Amplifier

## Application Information (continued)

### 8.1.5 Three-Band Active Tone Control (Bass, Midrange, and Treble)

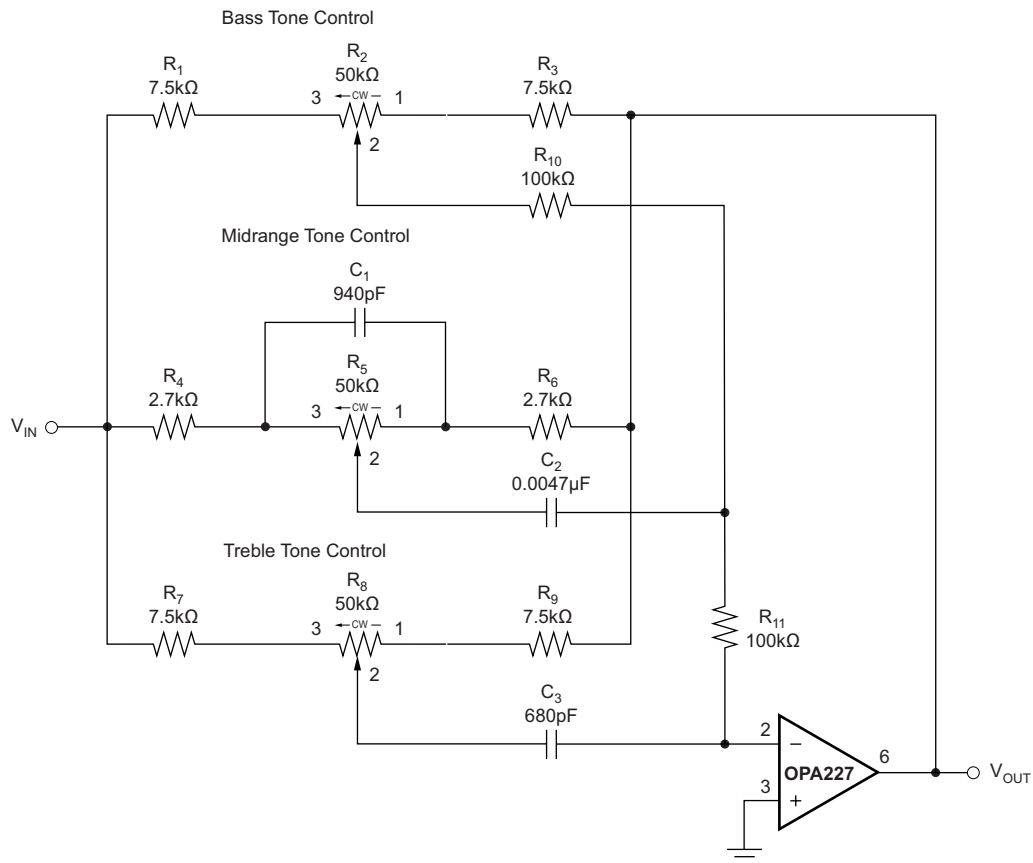

Figure 49. Three-Band Active Tone Control (Bass, Midrange, and Treble)

## 8.2 Typical Application

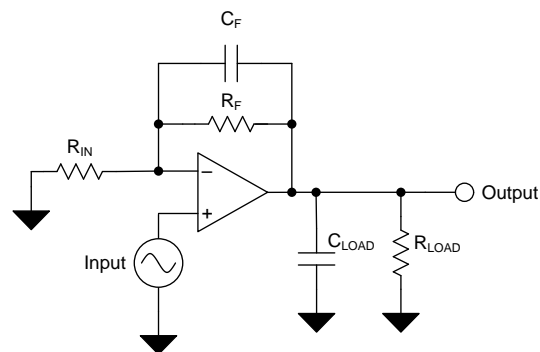

Figure 50. Typical Application Schematic

### 8.2.1 Design Requirements

1. Operate OPAx228 gain is less than 5 V/V
2. Stable operation with capacitive load

## Typical Application (continued)

### 8.2.2 Detailed Design Procedure

#### 8.2.2.1 Using the OPAx228 in Low Gains

The OPAx228 family is intended for applications with signal gains of 5 or greater, but it is possible to take advantage of their high-speed in lower gains. Without external compensation, the OPA228 has sufficient phase margin to maintain stability in unity gain with purely resistive loads. However, the addition of load capacitance can reduce the phase margin and destabilize the operational amplifier.

A variety of compensation techniques have been evaluated specifically for use with the OPA228. The recommended configuration consists of an additional capacitor ( $C_F$ ) in parallel with the feedback resistance, as shown in Figure 51 and Figure 52. This feedback capacitor serves two purposes in compensating the circuit. The operational amplifier's input capacitance and the feedback resistors interact to cause phase shift that can result in instability.  $C_F$  compensates the input capacitance, minimizing peaking. Additionally, at high frequencies, the closed-loop gain of the amplifier is strongly influenced by the ratio of the input capacitance and the feedback capacitor. Thus,  $C_F$  can be selected to yield good stability while maintaining high-speed.

Without external compensation, the noise specification of the OPA228 is the same as that for the OPA227 in gains of 5 or greater. With the additional external compensation, the output noise of the of the OPA228 will be higher. The amount of noise increase is directly related to the increase in high-frequency closed-loop gain established by the  $C_{IN}/C_F$  ratio.

Figure 51 and Figure 52 show the recommended circuit for gains of 2 and  $-2$ , respectively. The figures suggest approximate values for  $C_F$ . Because compensation is highly dependent on circuit design, board layout, and load conditions,  $C_F$  should be optimized experimentally for best results. Figure 53 and Figure 55 show the large- and small-signal step responses for the  $G = 2$  configuration with 100-pF load capacitance. Figure 54 and Figure 56 show the large- and small-signal step responses for the  $G = -2$  configuration with 100-pF load capacitance.



Figure 51. Compensation of the OPA228 for  $G = 2$

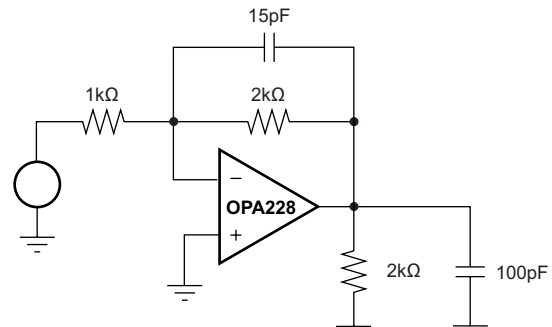

Figure 52. Compensation for OPA228 for  $G = -2$

### 8.2.3 Application Curves

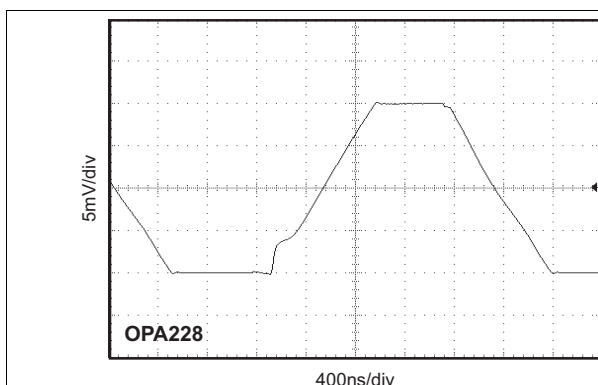

Figure 53. Large-Signal Step Response,  $G = 2$ ,  $C_{LOAD} = 100$  pF, Input Signal = 5 Vp-p

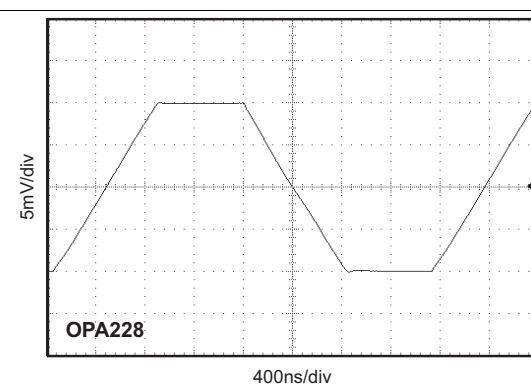
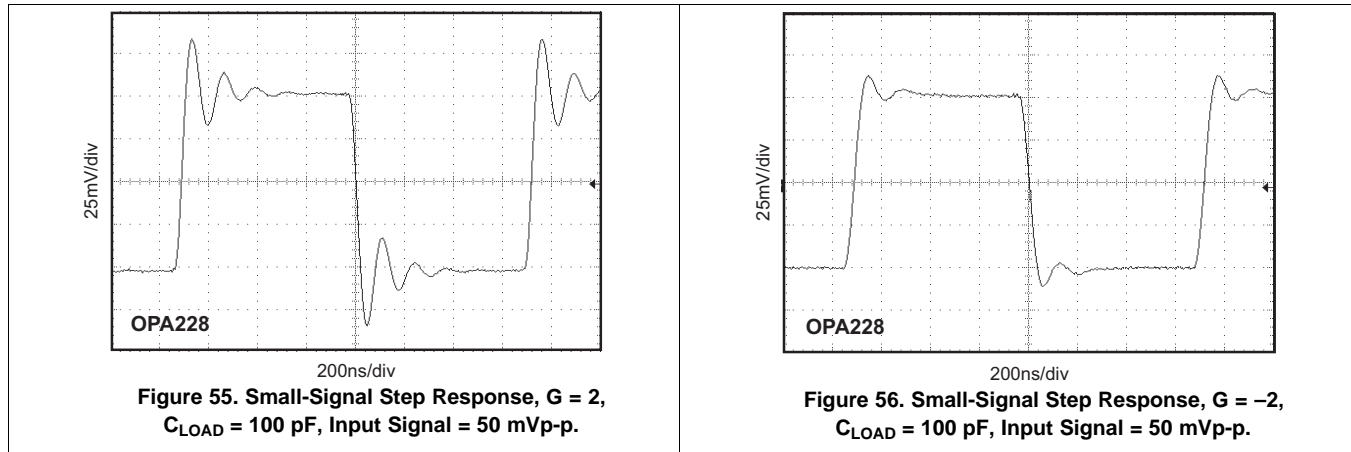

Figure 54. Large-Signal Step Response,  $G = -2$ ,  $C_{LOAD} = 100$  pF, Input Signal = 5 Vp-p

## Typical Application (continued)



## 9 Power Supply Recommendations

The OPAx22x series are specified for operation from 5 V to 36 V ( $\pm 2.5$  V to  $\pm 18$  V); many specifications apply from  $-40^{\circ}\text{C}$  to  $85^{\circ}\text{C}$ . Parameters that can exhibit significant variance with regard to operating voltage or temperature are presented in the [Electrical Characteristics: OPAx227 Series \( \$V\_S = \pm 5\$  V to  \$\pm 15\$  V\)](#).

### CAUTION

Supply voltages larger than 36 V can permanently damage the device; see the [Absolute Maximum Ratings](#).

Place 0.1- $\mu\text{F}$  bypass capacitors close to the power-supply pins to reduce errors coupling in from noisy or high-impedance power supplies. For more detailed information on bypass capacitor placement, refer to the [Layout Guidelines](#).

## 10 Layout

### 10.1 Layout Guidelines

For best operational performance of the device, use good PCB layout practices, including:

- Noise can propagate into analog circuitry through the power pins of the circuit as a whole and operational amplifier itself. Bypass capacitors are used to reduce the coupled noise by providing low-impedance power sources local to the analog circuitry.
  - Connect low-ESR, 0.1- $\mu\text{F}$  ceramic bypass capacitors between each supply pin and ground, placed as close to the device as possible. A single bypass capacitor from V+ to ground is applicable for single-supply applications.
- Separate grounding for analog and digital portions of circuitry is one of the simplest and most-effective methods of noise suppression. One or more layers on multilayer PCBs are usually devoted to ground planes. A ground plane helps distribute heat and reduces EMI noise pickup. Make sure to physically separate digital and analog grounds paying attention to the flow of the ground current. For more detailed information refer to [Circuit Board Layout Techniques \(SLOA089\)](#).
- To reduce parasitic coupling, run the input traces as far away from the supply or output traces as possible. If these traces cannot be kept separate, crossing the sensitive trace perpendicular is much better as opposed to in parallel with the noisy trace.
- Place the external components as close to the device as possible. As shown in [Layout Example](#), keeping RF and RG close to the inverting input minimizes parasitic capacitance.
- Keep the length of input traces as short as possible. Always remember that the input traces are the most sensitive part of the circuit.
- Consider a driven, low-impedance guard ring around the critical traces. A guard ring can significantly reduce leakage currents from nearby traces that are at different potentials.
- Cleaning the PCB following board assembly is recommended for best performance.
- Any precision integrated circuit may experience performance shifts due to moisture ingress into the plastic package. Following any aqueous PCB cleaning process, baking the PCB assembly is recommended to remove moisture introduced into the device packaging during the cleaning process. A low temperature, post cleaning bake at  $85^{\circ}\text{C}$  for 30 minutes is sufficient for most circumstances.

## 10.2 Layout Example

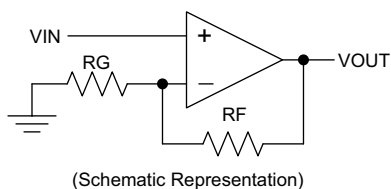

Figure 57. OPAx227 Layout Example

## 11 Device and Documentation Support

### 11.1 Device Support

#### 11.1.1 Development Support

##### 11.1.1.1 TINA-TI™ (Free Software Download)

TINA™ is a simple, powerful, and easy-to-use circuit simulation program based on a SPICE engine. TINA-TI is a free, fully-functional version of the TINA software, preloaded with a library of macro models in addition to a range of both passive and active models. TINA-TI provides all the conventional DC, transient, and frequency domain analysis of SPICE, as well as additional design capabilities.

Available as a [free download](#) from the Analog eLab Design Center, TINA-TI offers extensive post-processing capability that allows users to format results in a variety of ways. Virtual instruments offer the ability to select input waveforms and probe circuit nodes, voltages, and waveforms, creating a dynamic quick-start tool.

#### NOTE

These files require that either the TINA software (from DesignSoft™) or TINA-TI software be installed. Download the free TINA-TI software from the [TINA-TI folder](#).

##### 11.1.1.2 TI Precision Designs

The OPAx22x are featured in several TI Precision Designs, available online at <http://www.ti.com/ww/en/analog/precision-designs/>. TI Precision Designs are analog solutions created by TI's precision analog applications experts and offer the theory of operation, component selection, simulation, complete PCB schematic and layout, bill of materials, and measured performance of many useful circuits.

### 11.2 Documentation Support

#### 11.2.1 Related Documentation

*Circuit Board Layout Techniques*, [SLOA089](#)

*EMI Rejection Ratio of Operational Amplifiers*, [SBOA128](#)

#### 11.3 Related Links

The table below lists quick access links. Categories include technical documents, support and community resources, tools and software, and quick access to sample or buy.

**Table 2. Related Links**

PARTS	PRODUCT FOLDER	SAMPLE & BUY	TECHNICAL DOCUMENTS	TOOLS & SOFTWARE	SUPPORT & COMMUNITY
OPA227	<a href="#">Click here</a>	<a href="#">Click here</a>	<a href="#">Click here</a>	<a href="#">Click here</a>	<a href="#">Click here</a>
OPA2227	<a href="#">Click here</a>	<a href="#">Click here</a>	<a href="#">Click here</a>	<a href="#">Click here</a>	<a href="#">Click here</a>
OPA4227	<a href="#">Click here</a>	<a href="#">Click here</a>	<a href="#">Click here</a>	<a href="#">Click here</a>	<a href="#">Click here</a>
OPA228	<a href="#">Click here</a>	<a href="#">Click here</a>	<a href="#">Click here</a>	<a href="#">Click here</a>	<a href="#">Click here</a>
OPA2228	<a href="#">Click here</a>	<a href="#">Click here</a>	<a href="#">Click here</a>	<a href="#">Click here</a>	<a href="#">Click here</a>
OPA4228	<a href="#">Click here</a>	<a href="#">Click here</a>	<a href="#">Click here</a>	<a href="#">Click here</a>	<a href="#">Click here</a>

#### 11.4 Trademarks

TINA-TI is a trademark of Texas Instruments, Inc.  
 TINA, DesignSoft are trademarks of DesignSoft, Inc.  
 All other trademarks are the property of their respective owners.

## 11.5 Electrostatic Discharge Caution



These devices have limited built-in ESD protection. The leads should be shorted together or the device placed in conductive foam during storage or handling to prevent electrostatic damage to the MOS gates.

## 11.6 Glossary

[SLYZ022](#) — *TI Glossary*.

This glossary lists and explains terms, acronyms, and definitions.

## 12 Mechanical, Packaging, and Orderable Information

The following pages include mechanical, packaging, and orderable information. This information is the most current data available for the designated devices. This data is subject to change without notice and revision of this document. For browser-based versions of this data sheet, refer to the left-hand navigation.

**PACKAGING INFORMATION**

Orderable Device	Status (1)	Package Type	Package Drawing	Pins	Package Qty	Eco Plan (2)	Lead/Ball Finish (6)	MSL Peak Temp (3)	Op Temp (°C)	Device Marking (4/5)	Samples
OPA2227P	ACTIVE	PDIP	P	8	50	Green (RoHS & no Sb/Br)	CU NIPDAU   Call TI	N / A for Pkg Type	-40 to 85	OPA2227P	<a href="#">Samples</a>
OPA2227PA	ACTIVE	PDIP	P	8	50	Green (RoHS & no Sb/Br)	CU NIPDAU   Call TI	N / A for Pkg Type	-40 to 85	OPA2227P A	<a href="#">Samples</a>
OPA2227U	ACTIVE	SOIC	D	8	75	Green (RoHS & no Sb/Br)	CU NIPDAU	Level-3-260C-168 HR	-40 to 85	OPA 2227U	<a href="#">Samples</a>
OPA2227U/2K5	ACTIVE	SOIC	D	8	2500	Green (RoHS & no Sb/Br)	CU NIPDAU	Level-3-260C-168 HR	-40 to 85	OPA 2227U	<a href="#">Samples</a>
OPA2227U/2K5G4	ACTIVE	SOIC	D	8	2500	Green (RoHS & no Sb/Br)	CU NIPDAU	Level-3-260C-168 HR	-40 to 85	OPA 2227U	<a href="#">Samples</a>
OPA2227UA	ACTIVE	SOIC	D	8	75	Green (RoHS & no Sb/Br)	CU NIPDAU	Level-3-260C-168 HR	-40 to 85	OPA 2227U A	<a href="#">Samples</a>
OPA2227UA/2K5	ACTIVE	SOIC	D	8	2500	Green (RoHS & no Sb/Br)	CU NIPDAU	Level-3-260C-168 HR	-40 to 85	OPA 2227U A	<a href="#">Samples</a>
OPA2227UA/2K5E4	ACTIVE	SOIC	D	8	2500	Green (RoHS & no Sb/Br)	CU NIPDAU	Level-3-260C-168 HR	-40 to 85	OPA 2227U A	<a href="#">Samples</a>
OPA2227UAE4	ACTIVE	SOIC	D	8	75	Green (RoHS & no Sb/Br)	CU NIPDAU	Level-3-260C-168 HR	-40 to 85	OPA 2227U A	<a href="#">Samples</a>
OPA2227UAG4	ACTIVE	SOIC	D	8	75	Green (RoHS & no Sb/Br)	CU NIPDAU	Level-3-260C-168 HR	-40 to 85	OPA 2227U A	<a href="#">Samples</a>
OPA2227UE4	ACTIVE	SOIC	D	8	75	Green (RoHS & no Sb/Br)	CU NIPDAU	Level-3-260C-168 HR	-40 to 85	OPA 2227U	<a href="#">Samples</a>
OPA2227UG4	ACTIVE	SOIC	D	8	75	Green (RoHS & no Sb/Br)	CU NIPDAU	Level-3-260C-168 HR	-40 to 85	OPA 2227U	<a href="#">Samples</a>
OPA2228P	ACTIVE	PDIP	P	8	50	Green (RoHS & no Sb/Br)	CU NIPDAU   Call TI	N / A for Pkg Type	-40 to 85	OPA2228P	<a href="#">Samples</a>
OPA2228PA	ACTIVE	PDIP	P	8	50	Green (RoHS & no Sb/Br)	CU NIPDAU   Call TI	N / A for Pkg Type	-40 to 85	OPA2228P A	<a href="#">Samples</a>
OPA2228PAG4	ACTIVE	PDIP	P	8	50	Green (RoHS & no Sb/Br)	Call TI	N / A for Pkg Type	-40 to 85	OPA2228P A	<a href="#">Samples</a>

Orderable Device	Status (1)	Package Type	Package Drawing	Pins	Package Qty	Eco Plan (2)	Lead/Ball Finish (6)	MSL Peak Temp (3)	Op Temp (°C)	Device Marking (4/5)	Samples
OPA2228PG4	ACTIVE	PDIP	P	8	50	Green (RoHS & no Sb/Br)	Call TI	N / A for Pkg Type	-40 to 85	OPA2228P	<a href="#">Samples</a>
OPA2228U	ACTIVE	SOIC	D	8	75	Green (RoHS & no Sb/Br)	CU NIPDAU	Level-3-260C-168 HR	-40 to 85	OPA 2228U	<a href="#">Samples</a>
OPA2228U/2K5	ACTIVE	SOIC	D	8	2500	Green (RoHS & no Sb/Br)	CU NIPDAU	Level-3-260C-168 HR	-40 to 85	OPA 2228U	<a href="#">Samples</a>
OPA2228UA	ACTIVE	SOIC	D	8	75	Green (RoHS & no Sb/Br)	CU NIPDAU	Level-3-260C-168 HR	-40 to 85	OPA 2228U A	<a href="#">Samples</a>
OPA2228UA/2K5	ACTIVE	SOIC	D	8	2500	Green (RoHS & no Sb/Br)	CU NIPDAU	Level-3-260C-168 HR	-40 to 85	OPA 2228U A	<a href="#">Samples</a>
OPA2228UA/2K5E4	ACTIVE	SOIC	D	8	2500	Green (RoHS & no Sb/Br)	CU NIPDAU	Level-3-260C-168 HR	-40 to 85	OPA 2228U A	<a href="#">Samples</a>
OPA2228UE4	ACTIVE	SOIC	D	8	75	Green (RoHS & no Sb/Br)	CU NIPDAU	Level-3-260C-168 HR	-40 to 85	OPA 2228U	<a href="#">Samples</a>
OPA227P	ACTIVE	PDIP	P	8	50	Green (RoHS & no Sb/Br)	CU NIPDAU   Call TI	N / A for Pkg Type	-40 to 85	OPA227P	<a href="#">Samples</a>
OPA227PA	ACTIVE	PDIP	P	8	50	Green (RoHS & no Sb/Br)	CU NIPDAU   Call TI	N / A for Pkg Type	-40 to 85	OPA227P A	<a href="#">Samples</a>
OPA227PAG4	ACTIVE	PDIP	P	8	50	Green (RoHS & no Sb/Br)	Call TI	N / A for Pkg Type	-40 to 85	OPA227P A	<a href="#">Samples</a>
OPA227PG4	ACTIVE	PDIP	P	8	50	Green (RoHS & no Sb/Br)	Call TI	N / A for Pkg Type	-40 to 85	OPA227P	<a href="#">Samples</a>
OPA227U	ACTIVE	SOIC	D	8	75	Green (RoHS & no Sb/Br)	CU NIPDAU	Level-3-260C-168 HR	-40 to 85	OPA 227U	<a href="#">Samples</a>
OPA227U/2K5	ACTIVE	SOIC	D	8	2500	Green (RoHS & no Sb/Br)	CU NIPDAU	Level-3-260C-168 HR	-40 to 85	OPA 227U	<a href="#">Samples</a>
OPA227U/2K5E4	ACTIVE	SOIC	D	8	2500	Green (RoHS & no Sb/Br)	CU NIPDAU	Level-3-260C-168 HR	-40 to 85	OPA 227U	<a href="#">Samples</a>
OPA227UA	ACTIVE	SOIC	D	8	75	Green (RoHS & no Sb/Br)	CU NIPDAU	Level-3-260C-168 HR	-40 to 85	OPA 227U A	<a href="#">Samples</a>
OPA227UA/2K5	ACTIVE	SOIC	D	8	2500	Green (RoHS & no Sb/Br)	CU NIPDAU	Level-3-260C-168 HR	-40 to 85	OPA 227U A	<a href="#">Samples</a>

Orderable Device	Status (1)	Package Type	Package Drawing	Pins	Package Qty	Eco Plan (2)	Lead/Ball Finish (6)	MSL Peak Temp (3)	Op Temp (°C)	Device Marking (4/5)	Samples
OPA227UA/2K5G4	ACTIVE	SOIC	D	8	2500	Green (RoHS & no Sb/Br)	CU NIPDAU	Level-3-260C-168 HR	-40 to 85	OPA 227U A	<a href="#">Samples</a>
OPA228P	ACTIVE	PDIP	P	8	50	Green (RoHS & no Sb/Br)	CU NIPDAU   Call TI	N / A for Pkg Type	-55 to 125	OPA228P	<a href="#">Samples</a>
OPA228PA	ACTIVE	PDIP	P	8	50	Green (RoHS & no Sb/Br)	CU NIPDAU   Call TI	N / A for Pkg Type	-55 to 125	OPA228P A	<a href="#">Samples</a>
OPA228PAG4	ACTIVE	PDIP	P	8	50	Green (RoHS & no Sb/Br)	Call TI	N / A for Pkg Type	-55 to 125	OPA228P A	<a href="#">Samples</a>
OPA228U	ACTIVE	SOIC	D	8	75	Green (RoHS & no Sb/Br)	CU NIPDAU	Level-3-260C-168 HR	-55 to 125	OPA 228U	<a href="#">Samples</a>
OPA228UA	ACTIVE	SOIC	D	8	75	Green (RoHS & no Sb/Br)	CU NIPDAU	Level-3-260C-168 HR	-55 to 125	OPA 228U A	<a href="#">Samples</a>
OPA228UA/2K5	ACTIVE	SOIC	D	8	2500	Green (RoHS & no Sb/Br)	CU NIPDAU	Level-3-260C-168 HR	-55 to 125	OPA 228U A	<a href="#">Samples</a>
OPA228UAG4	ACTIVE	SOIC	D	8	75	Green (RoHS & no Sb/Br)	CU NIPDAU	Level-3-260C-168 HR	-55 to 125	OPA 228U A	<a href="#">Samples</a>
OPA228UG4	ACTIVE	SOIC	D	8	75	Green (RoHS & no Sb/Br)	CU NIPDAU	Level-3-260C-168 HR	-55 to 125	OPA 228U	<a href="#">Samples</a>
OPA4227PA	ACTIVE	PDIP	N	14	25	Green (RoHS & no Sb/Br)	CU NIPDAU	N / A for Pkg Type	-40 to 85	OPA4227PA	<a href="#">Samples</a>
OPA4227PAG4	ACTIVE	PDIP	N	14	25	Green (RoHS & no Sb/Br)	CU NIPDAU	N / A for Pkg Type	-40 to 85	OPA4227PA	<a href="#">Samples</a>
OPA4227UA	ACTIVE	SOIC	D	14	50	Green (RoHS & no Sb/Br)	CU NIPDAU-DCC	Level-3-260C-168 HR	-40 to 85	OPA4227UA	<a href="#">Samples</a>
OPA4227UA/2K5	ACTIVE	SOIC	D	14	2500	Green (RoHS & no Sb/Br)	CU NIPDAU-DCC	Level-3-260C-168 HR	-40 to 85	OPA4227UA	<a href="#">Samples</a>
OPA4227UA/2K5G4	ACTIVE	SOIC	D	14	2500	Green (RoHS & no Sb/Br)	CU NIPDAU-DCC	Level-3-260C-168 HR	-40 to 85	OPA4227UA	<a href="#">Samples</a>
OPA4227UAG4	ACTIVE	SOIC	D	14	50	Green (RoHS & no Sb/Br)	CU NIPDAU-DCC	Level-3-260C-168 HR	-40 to 85	OPA4227UA	<a href="#">Samples</a>
OPA4228PA	ACTIVE	PDIP	N	14	25	Green (RoHS & no Sb/Br)	CU NIPDAU	N / A for Pkg Type	-55 to 125	OPA4228PA	<a href="#">Samples</a>

Orderable Device	Status (1)	Package Type	Package Drawing	Pins	Package Qty	Eco Plan (2)	Lead/Ball Finish (6)	MSL Peak Temp (3)	Op Temp (°C)	Device Marking (4/5)	Samples
OPA4228PAG4	ACTIVE	PDIP	N	14	25	Green (RoHS & no Sb/Br)	CU NIPDAU	N / A for Pkg Type	-55 to 125	OPA4228PA	<a href="#">Samples</a>
OPA4228UA	ACTIVE	SOIC	D	14	50	Green (RoHS & no Sb/Br)	CU NIPDAU-DCC	Level-3-260C-168 HR	-55 to 125	OPA4228UA	<a href="#">Samples</a>
OPA4228UA/2K5	ACTIVE	SOIC	D	14	2500	Green (RoHS & no Sb/Br)	CU NIPDAU-DCC	Level-3-260C-168 HR	-55 to 125	OPA4228UA	<a href="#">Samples</a>
OPA4228UA/2K5G4	ACTIVE	SOIC	D	14	2500	Green (RoHS & no Sb/Br)	CU NIPDAU-DCC	Level-3-260C-168 HR	-55 to 125	OPA4228UA	<a href="#">Samples</a>

(1) The marketing status values are defined as follows:

**ACTIVE:** Product device recommended for new designs.

**LIFEBUY:** TI has announced that the device will be discontinued, and a lifetime-buy period is in effect.

**NRND:** Not recommended for new designs. Device is in production to support existing customers, but TI does not recommend using this part in a new design.

**PREVIEW:** Device has been announced but is not in production. Samples may or may not be available.

**OBsolete:** TI has discontinued the production of the device.

(2) **RoHS:** TI defines "RoHS" to mean semiconductor products that are compliant with the current EU RoHS requirements for all 10 RoHS substances, including the requirement that RoHS substance do not exceed 0.1% by weight in homogeneous materials. Where designed to be soldered at high temperatures, "RoHS" products are suitable for use in specified lead-free processes. TI may reference these types of products as "Pb-Free".

**RoHS Exempt:** TI defines "RoHS Exempt" to mean products that contain lead but are compliant with EU RoHS pursuant to a specific EU RoHS exemption.

**Green:** TI defines "Green" to mean the content of Chlorine (Cl) and Bromine (Br) based flame retardants meet JS709B low halogen requirements of <=1000ppm threshold. Antimony trioxide based flame retardants must also meet the <=1000ppm threshold requirement.

(3) MSL, Peak Temp. - The Moisture Sensitivity Level rating according to the JEDEC industry standard classifications, and peak solder temperature.

(4) There may be additional marking, which relates to the logo, the lot trace code information, or the environmental category on the device.

(5) Multiple Device Markings will be inside parentheses. Only one Device Marking contained in parentheses and separated by a "~" will appear on a device. If a line is indented then it is a continuation of the previous line and the two combined represent the entire Device Marking for that device.

(6) Lead/Ball Finish - Orderable Devices may have multiple material finish options. Finish options are separated by a vertical ruled line. Lead/Ball Finish values may wrap to two lines if the finish value exceeds the maximum column width.

**Important Information and Disclaimer:**The information provided on this page represents TI's knowledge and belief as of the date that it is provided. TI bases its knowledge and belief on information provided by third parties, and makes no representation or warranty as to the accuracy of such information. Efforts are underway to better integrate information from third parties. TI has taken and continues to take reasonable steps to provide representative and accurate information but may not have conducted destructive testing or chemical analysis on incoming materials and chemicals. TI and TI suppliers consider certain information to be proprietary, and thus CAS numbers and other limited information may not be available for release.

In no event shall TI's liability arising out of such information exceed the total purchase price of the TI part(s) at issue in this document sold by TI to Customer on an annual basis.

**OTHER QUALIFIED VERSIONS OF OPA2227 :**

- Enhanced Product: [OPA2227-EP](#)

**NOTE: Qualified Version Definitions:**

- Enhanced Product - Supports Defense, Aerospace and Medical Applications

**TAPE AND REEL INFORMATION**

**QUADRANT ASSIGNMENTS FOR PIN 1 ORIENTATION IN TAPE**

\*All dimensions are nominal

Device	Package Type	Package Drawing	Pins	SPQ	Reel Diameter (mm)	Reel Width W1 (mm)	A0 (mm)	B0 (mm)	K0 (mm)	P1 (mm)	W (mm)	Pin1 Quadrant
OPA2227U/2K5	SOIC	D	8	2500	330.0	12.4	6.4	5.2	2.1	8.0	12.0	Q1
OPA2227UA/2K5	SOIC	D	8	2500	330.0	12.4	6.4	5.2	2.1	8.0	12.0	Q1
OPA2228U/2K5	SOIC	D	8	2500	330.0	12.4	6.4	5.2	2.1	8.0	12.0	Q1
OPA2228UA/2K5	SOIC	D	8	2500	330.0	12.4	6.4	5.2	2.1	8.0	12.0	Q1
OPA227U/2K5	SOIC	D	8	2500	330.0	12.4	6.4	5.2	2.1	8.0	12.0	Q1
OPA227UA/2K5	SOIC	D	8	2500	330.0	12.4	6.4	5.2	2.1	8.0	12.0	Q1
OPA228UA/2K5	SOIC	D	8	2500	330.0	12.4	6.4	5.2	2.1	8.0	12.0	Q1
OPA4227UA/2K5	SOIC	D	14	2500	330.0	16.4	6.5	9.0	2.1	8.0	16.0	Q1
OPA4228UA/2K5	SOIC	D	14	2500	330.0	16.4	6.5	9.0	2.1	8.0	16.0	Q1

**TAPE AND REEL BOX DIMENSIONS**



\*All dimensions are nominal

Device	Package Type	Package Drawing	Pins	SPQ	Length (mm)	Width (mm)	Height (mm)
OPA2227U/2K5	SOIC	D	8	2500	367.0	367.0	35.0
OPA2227UA/2K5	SOIC	D	8	2500	367.0	367.0	35.0
OPA2228U/2K5	SOIC	D	8	2500	367.0	367.0	35.0
OPA2228UA/2K5	SOIC	D	8	2500	367.0	367.0	35.0
OPA227U/2K5	SOIC	D	8	2500	367.0	367.0	35.0
OPA227UA/2K5	SOIC	D	8	2500	367.0	367.0	35.0
OPA228UA/2K5	SOIC	D	8	2500	367.0	367.0	35.0
OPA4227UA/2K5	SOIC	D	14	2500	367.0	367.0	38.0
OPA4228UA/2K5	SOIC	D	14	2500	367.0	367.0	38.0

D (R-PDSO-G14)

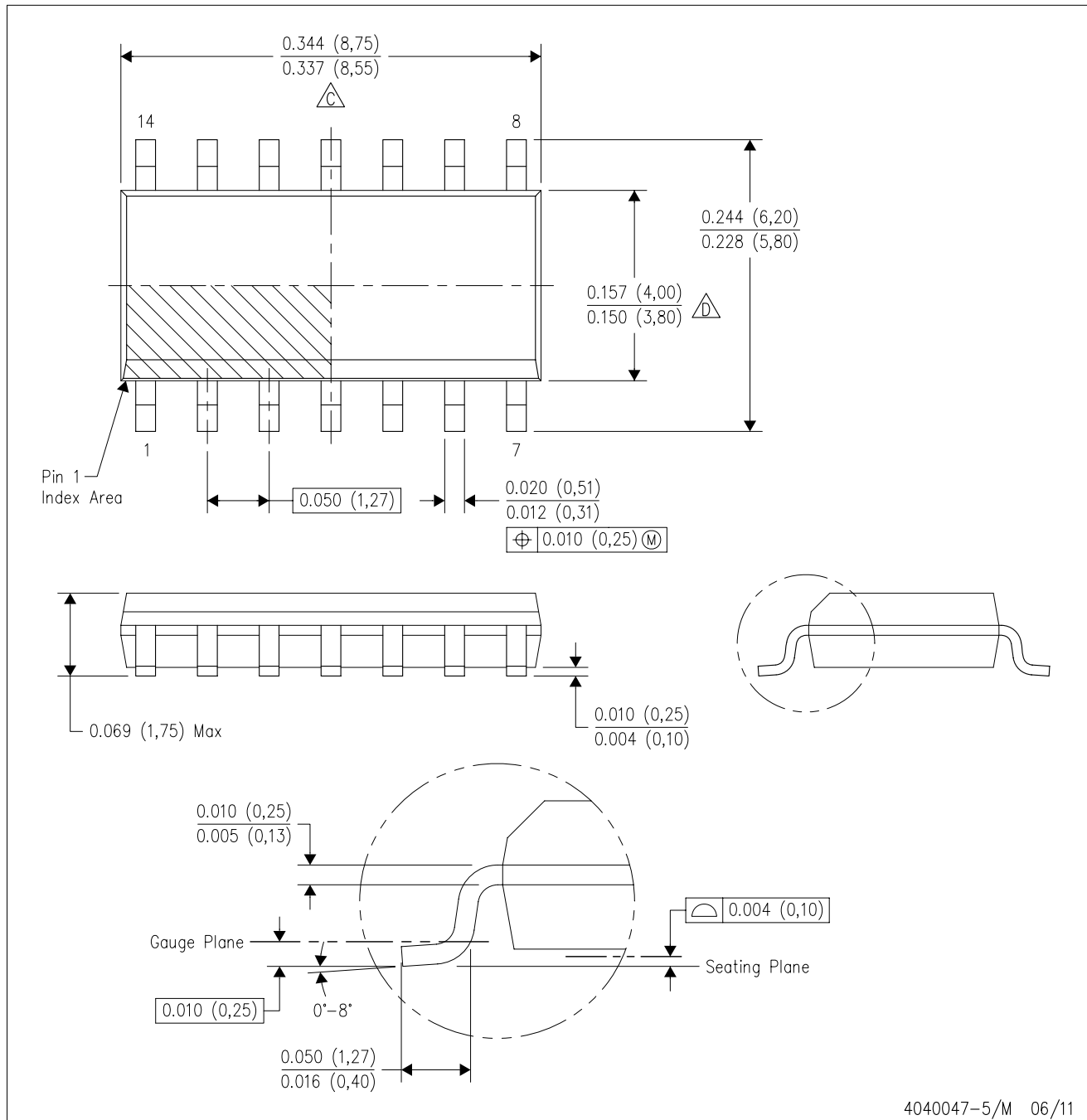
PLASTIC SMALL OUTLINE



- NOTES:
- A. All linear dimensions are in inches (millimeters).
  - B. This drawing is subject to change without notice.
  -  Body length does not include mold flash, protrusions, or gate burrs. Mold flash, protrusions, or gate burrs shall not exceed 0.006 (0,15) each side.
  -  Body width does not include interlead flash. Interlead flash shall not exceed 0.017 (0,43) each side.
  - E. Reference JEDEC MS-012 variation AB.

D (R-PDSO-G14)

PLASTIC SMALL OUTLINE

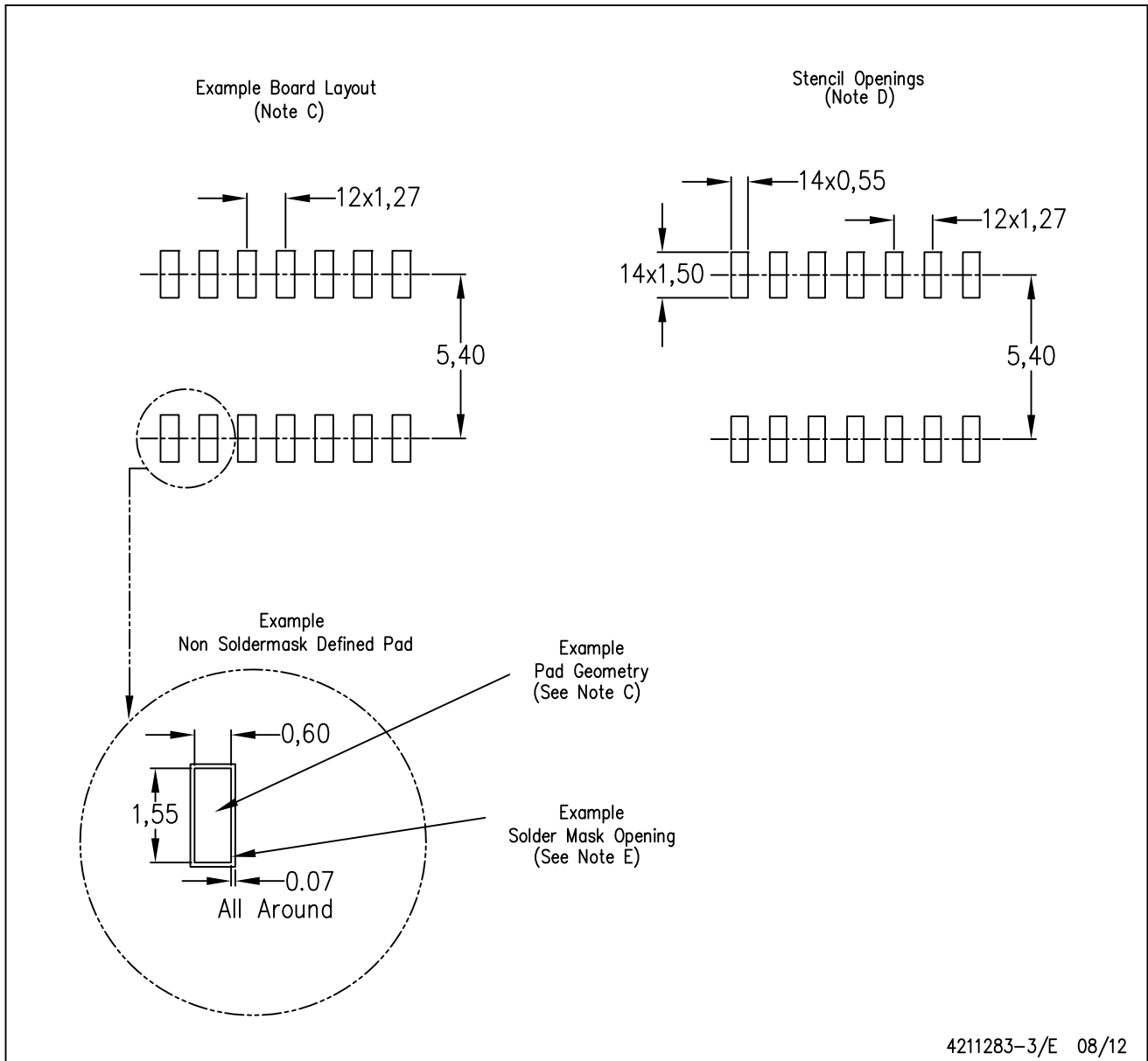

4211283-3/E 08/12

- NOTES:
- All linear dimensions are in millimeters.
  - This drawing is subject to change without notice.
  - Publication IPC-7351 is recommended for alternate designs.
  - Laser cutting apertures with trapezoidal walls and also rounding corners will offer better paste release. Customers should contact their board assembly site for stencil design recommendations. Refer to IPC-7525 for other stencil recommendations.
  - Customers should contact their board fabrication site for solder mask tolerances between and around signal pads.



# EXAMPLE BOARD LAYOUT

D0008A

SOIC - 1.75 mm max height

SMALL OUTLINE INTEGRATED CIRCUIT



LAND PATTERN EXAMPLE  
 EXPOSED METAL SHOWN  
 SCALE:8X



SOLDER MASK DETAILS

4214825/C 02/2019

NOTES: (continued)

- 6. Publication IPC-7351 may have alternate designs.
- 7. Solder mask tolerances between and around signal pads can vary based on board fabrication site.

# EXAMPLE STENCIL DESIGN

D0008A

SOIC - 1.75 mm max height

SMALL OUTLINE INTEGRATED CIRCUIT



SOLDER PASTE EXAMPLE  
BASED ON .005 INCH [0.125 MM] THICK STENCIL  
SCALE:8X

4214825/C 02/2019

NOTES: (continued)

8. Laser cutting apertures with trapezoidal walls and rounded corners may offer better paste release. IPC-7525 may have alternate design recommendations.
9. Board assembly site may have different recommendations for stencil design.

P (R-PDIP-T8)

PLASTIC DUAL-IN-LINE PACKAGE

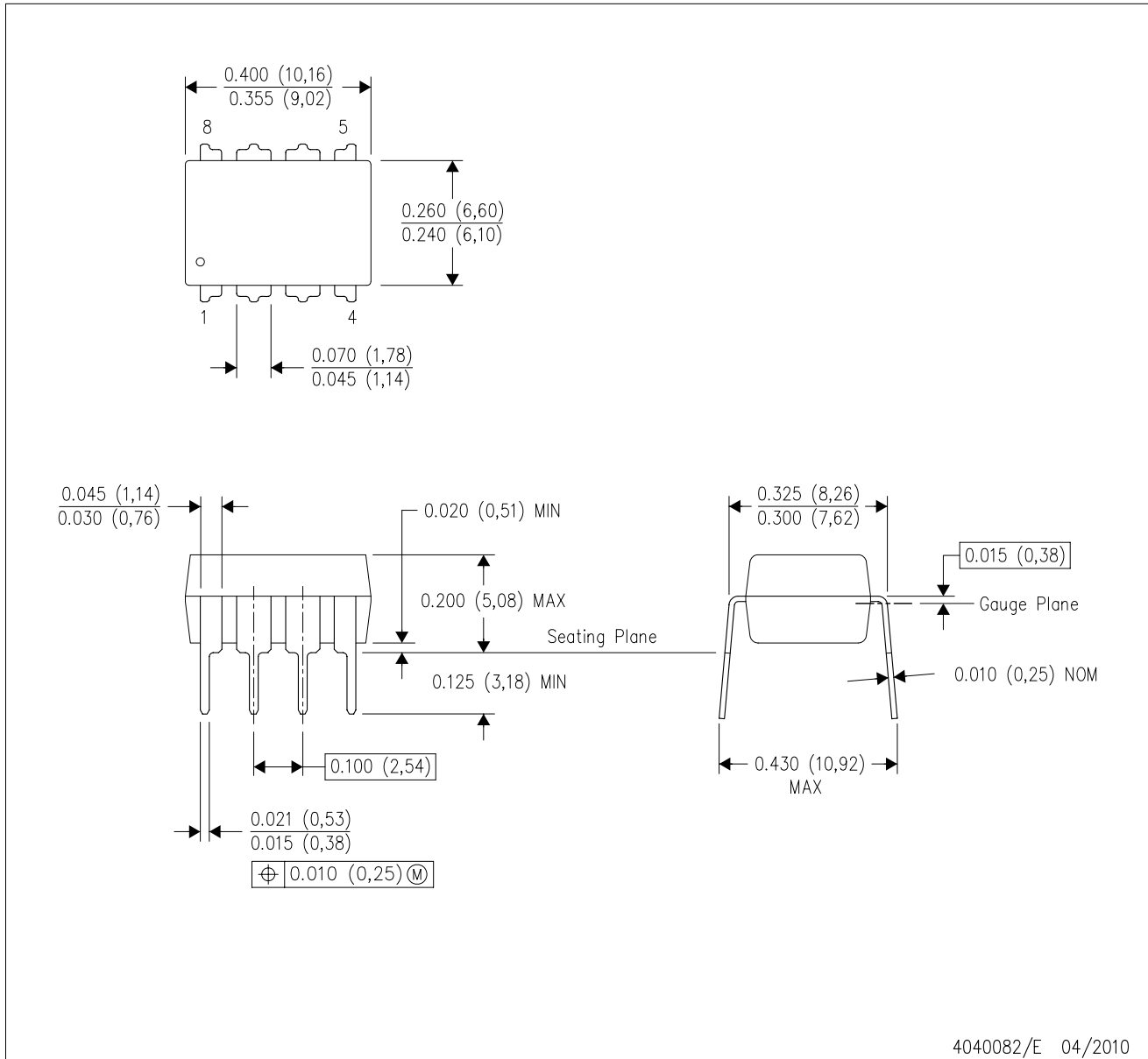

- NOTES:
- A. All linear dimensions are in inches (millimeters).
  - B. This drawing is subject to change without notice.
  - C. Falls within JEDEC MS-001 variation BA.

N (R-PDIP-T\*\*)

PLASTIC DUAL-IN-LINE PACKAGE

16 PINS SHOWN



- NOTES:
- A. All linear dimensions are in inches (millimeters).
  - B. This drawing is subject to change without notice.
  - C Falls within JEDEC MS-001, except 18 and 20 pin minimum body length (Dim A).
  - D The 20 pin end lead shoulder width is a vendor option, either half or full width.

4040049/E 12/2002

## IMPORTANT NOTICE AND DISCLAIMER

TI PROVIDES TECHNICAL AND RELIABILITY DATA (INCLUDING DATASHEETS), DESIGN RESOURCES (INCLUDING REFERENCE DESIGNS), APPLICATION OR OTHER DESIGN ADVICE, WEB TOOLS, SAFETY INFORMATION, AND OTHER RESOURCES "AS IS" AND WITH ALL FAULTS, AND DISCLAIMS ALL WARRANTIES, EXPRESS AND IMPLIED, INCLUDING WITHOUT LIMITATION ANY IMPLIED WARRANTIES OF MERCHANTABILITY, FITNESS FOR A PARTICULAR PURPOSE OR NON-INFRINGEMENT OF THIRD PARTY INTELLECTUAL PROPERTY RIGHTS.

These resources are intended for skilled developers designing with TI products. You are solely responsible for (1) selecting the appropriate TI products for your application, (2) designing, validating and testing your application, and (3) ensuring your application meets applicable standards, and any other safety, security, or other requirements. These resources are subject to change without notice. TI grants you permission to use these resources only for development of an application that uses the TI products described in the resource. Other reproduction and display of these resources is prohibited. No license is granted to any other TI intellectual property right or to any third party intellectual property right. TI disclaims responsibility for, and you will fully indemnify TI and its representatives against, any claims, damages, costs, losses, and liabilities arising out of your use of these resources.

TI's products are provided subject to TI's Terms of Sale ([www.ti.com/legal/termsofsale.html](http://www.ti.com/legal/termsofsale.html)) or other applicable terms available either on [ti.com](http://ti.com) or provided in conjunction with such TI products. TI's provision of these resources does not expand or otherwise alter TI's applicable warranties or warranty disclaimers for TI products.

Mailing Address: Texas Instruments, Post Office Box 655303, Dallas, Texas 75265  
Copyright © 2019, Texas Instruments Incorporated

## Looking for pricing, stock, or lifecycle information?

Click below to explore more details on WIN SOURCE:

 [View OPA2228P](#) on WIN SOURCE

 [Texas Instruments](#) Information

## Optimize Your Supply Chain with WIN SOURCE Solutions

-  Global Sourcing Solution
-  Obsolete Management
-  Cost Control Management
-  Shortage Management
-  Alternative Solution
-  Excess Inventory Management