



THE DATASHEET OF OPA365AIDBVT



OPAx365 50-MHz, Zero-Crossover, Low-Distortion, High CMRR, RRI/O, Single-Supply Operational Amplifier

1 Features

- Gain Bandwidth: 50 MHz
- Zero-Crossover Distortion Topology:
 - Excellent THD+N: 0.0004%
 - CMRR: 100 dB (Minimum)
 - Rail-to-Rail Input and Output
 - Input 100 mV Beyond Supply Rail
- Low Noise: 4.5 nV/ $\sqrt{\text{Hz}}$ at 100 kHz
- Slew Rate: 25 V/ μs
- Fast Settling: 0.3 μs to 0.01%
- Precision:
 - Low Offset: 100 μV
 - Low Input Bias Current: 0.2 pA
- 2.2-V to 5.5-V Operation

2 Applications

- Signal Conditioning
- Data Acquisition
- Process Control
- Active Filters
- Test Equipment
- Audio
- Wideband Amplifiers

3 Description

The OPAx365 zero-crossover series, rail-to-rail, high-performance, CMOS operational amplifiers are optimized for very low voltage, single-supply applications. Rail-to-rail input or output, low-noise (4.5 nV/ $\sqrt{\text{Hz}}$) and high-speed operation (50-MHz Gain Bandwidth) make these devices ideal for driving sampling analog-to-digital converters (ADCs). Applications include audio, signal conditioning, and sensor amplification. The OPA365 family of op amps are also well-suited for cell phone power amplifier control loops.

Special features include an excellent common-mode rejection ratio (CMRR), no input stage crossover distortion, high input impedance, and rail-to-rail input and output swing. The input common-mode range includes both the negative and positive supplies. The output voltage swing is within 10 mV of the rails.

The OPA365 (single version) is available in the micro-size SOT23-5 (SOT-5) and SOIC-8 packages. The OPA2365 (dual version) is offered in the SOIC-8 package. All versions are specified for operation from -40°C to $+125^{\circ}\text{C}$. Single and dual versions have identical specifications for maximum design flexibility.

Device Information⁽¹⁾

PART NUMBER	PACKAGE	BODY SIZE (NOM)
OPA365, OPA2365	SOIC (8)	4.90 mm x 3.91 mm
	SOT-23 (5)	2.90 mm x 1.60 mm

(1) For all available packages, see the orderable addendum at the end of the data sheet.

Fast Settling Peak Detector

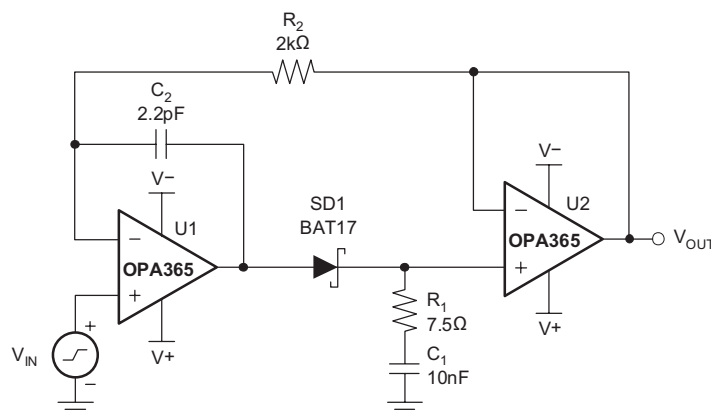

Copyright © 2016, Texas Instruments Incorporated



Table of Contents

1 Features	1	8 Application and Implementation	16
2 Applications	1	8.1 Application Information.....	16
3 Description	1	8.2 Typical Application	17
4 Revision History	2	8.3 System Examples	18
5 Pin Configuration and Functions	3	9 Power Supply Recommendations	21
6 Specifications	4	10 Layout	21
6.1 Absolute Maximum Ratings	4	10.1 Layout Guidelines	21
6.2 ESD Ratings.....	4	10.2 Layout Example	22
6.3 Recommended Operating Conditions.....	4	11 Device and Documentation Support	23
6.4 Thermal Information: OP365.....	4	11.1 Device Support	23
6.5 Thermal Information: OPA2365	5	11.2 Documentation Support	24
6.6 Electrical Characteristics.....	5	11.3 Related Links	24
6.7 Typical Characteristics	7	11.4 Community Resources.....	24
7 Detailed Description	11	11.5 Trademarks	24
7.1 Overview	11	11.6 Electrostatic Discharge Caution.....	24
7.2 Functional Block Diagram	11	11.7 Glossary	24
7.3 Feature Description.....	12	12 Mechanical, Packaging, and Orderable	
7.4 Device Functional Modes.....	15	Information	24

4 Revision History

Changes from Revision D (June 2009) to Revision E

Page

- Added *ESD Ratings* table, *Feature Description* section, *Device Functional Modes*, *Application and Implementation* section, *Power Supply Recommendations* section, *Layout* section, *Device and Documentation Support* section, and *Mechanical, Packaging, and Orderable Information* section. **1**
- Added current package designators to last paragraph of *Description* section

5 Pin Configuration and Functions

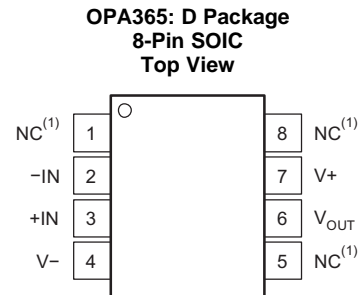
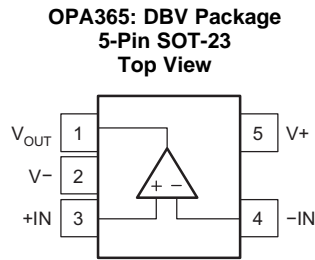

(1) NC denotes no internal connection.

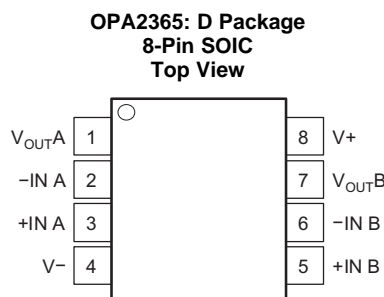

Pin Functions: OPA365

NAME	PIN		I/O	DESCRIPTION
	SOIC	SOT		
-IN	2	4	I	Negative (inverting) input
+IN	3	3	I	Positive (noninverting) input
V-	4	2	—	Negative (lowest) power supply
V+	7	5	—	Positive (highest) power supply
V _{OUT}	6	1	O	Output
NC	1, 5, 8	—	—	No internal connection (can be left floating)

Pin Functions: OPA2365

NAME	PIN		I/O	DESCRIPTION
	SOIC			
-IN A	2		I	Negative (inverting) input signal, channel A
+IN A	3		I	Positive (noninverting) input signal, channel A
-IN B	6		I	Negative (inverting) input signal, channel B
+IN B	5		I	Positive (noninverting) input signal, channel B
V-	4		—	Negative (lowest) power supply
V+	8		—	Positive (highest) power supply
V _{OUTA}	1		O	Output, channel A
V _{OUTB}	7		O	Output, channel B

6 Specifications

6.1 Absolute Maximum Ratings

over operating free-air temperature range (unless otherwise noted)⁽¹⁾

		MIN	MAX	UNIT
Voltage	Supply voltage		5.5	V
	Signal input terminals, voltage ⁽²⁾	-0.5	0.5	V
Current	Signal input terminals, current ⁽²⁾	-10	10	mA
	Output short-circuit ⁽³⁾	Continuous		
Temperature	Operating, T _A	-40	150	°C
	Junction, T _J		150	°C
	Storage, T _{stg}	-65	150	°C

- Stresses beyond those listed under *Absolute Maximum Ratings* may cause permanent damage to the device. These are stress ratings only, which do not imply functional operation of the device at these or any other conditions beyond those indicated under *Recommended Operating Conditions*. Exposure to absolute-maximum-rated conditions for extended periods may affect device reliability.
- Input terminals are diode-clamped to the power-supply rails. Input signals that can swing more than 0.5 V beyond the supply rails should be current limited to 10 mA or less.
- Short-circuit to ground, one amplifier per package.

6.2 ESD Ratings

		VALUE	UNIT
V _(ESD) Electrostatic discharge	Human-body model (HBM), per ANSI/ESDA/JEDEC JS-001 ⁽¹⁾	±4000	V
	Charged-device model (CDM), per JEDEC specification JESD22-C101 ⁽²⁾	±1000	
	Machine model	±400	

- JEDEC document JEP155 states that 500-V HBM allows safe manufacturing with a standard ESD control process.
- JEDEC document JEP157 states that 250-V CDM allows safe manufacturing with a standard ESD control process.

6.3 Recommended Operating Conditions

over operating free-air temperature range (unless otherwise noted)

	MIN	NOM	MAX	UNIT
Power supply voltage, (V+) – (V-)	2.2		5.5	V
Specified temperature	-40		+125	°C
Operating temperature	-40		+150	°C

6.4 Thermal Information: OP365

THERMAL METRIC ⁽¹⁾		OPA365		UNIT
		DBV (SOT-23)	D (SOIC)	
		5 PINS	8 PINS	
R _{θJA}	Junction-to-ambient thermal resistance	206.9	140.1	°C/W
R _{θJC(top)}	Junction-to-case (top) thermal resistance	69.4	89.8	°C/W
R _{θJB}	Junction-to-board thermal resistance	34.2	80.6	°C/W
ψ _{JT}	Junction-to-top characterization parameter	1.8	28.7	°C/W
ψ _{JB}	Junction-to-board characterization parameter	33.9	80.1	°C/W
R _{θJC(bot)}	Junction-to-case (bottom) thermal resistance	n/a	n/a	°C/W

- For more information about traditional and new thermal metrics, see the [Semiconductor and IC Package Thermal Metrics](#) application report.

6.5 Thermal Information: OPA2365

THERMAL METRIC ⁽¹⁾		OPA2365	
		D (SOIC)	
		8 PINS	
			UNIT
$R_{\theta JA}$	Junction-to-ambient thermal resistance	115.5	°C/W
$R_{\theta JC(top)}$	Junction-to-case (top) thermal resistance	60.1	°C/W
$R_{\theta JB}$	Junction-to-board thermal resistance	56.9	°C/W
ψ_{JT}	Junction-to-top characterization parameter	9.5	°C/W
ψ_{JB}	Junction-to-board characterization parameter	56.3	°C/W
$R_{\theta JC(bot)}$	Junction-to-case (bottom) thermal resistance	n/a	°C/W

(1) For more information about traditional and new thermal metrics, see the [Semiconductor and IC Package Thermal Metrics](#) application report.

6.6 Electrical Characteristics

At $T_A = 25^\circ\text{C}$, $R_L = 10\text{ k}\Omega$ connected to $V_S/2$, $V_{CM} = V_S/2$, and $V_{OUT} = V_S/2$, unless otherwise noted.

PARAMETER		TEST CONDITIONS	MIN	TYP	MAX	UNIT
OFFSET VOLTAGE						
V_{OS}	Input offset voltage			100	200	μV
dV_{OS}/dT	Input offset voltage versus drift	At $T_A = -40^\circ\text{C}$ to $+125^\circ\text{C}$		1		$\mu\text{V}/^\circ\text{C}$
PSRR	Input offset voltage versus power supply	$V_S = 2.2\text{ V}$ to 5.5 V , at $T_A = -40^\circ\text{C}$ to $+125^\circ\text{C}$		10		$\mu\text{V}/\text{V}$
	Channel separation, DC			0.2		$\mu\text{V}/\text{V}$
INPUT BIAS CURRENT						
I_B	Input bias current			± 0.2	± 10	μA
	Over temperature	At $T_A = -40^\circ\text{C}$ to $+125^\circ\text{C}$	See Typical Characteristics			
I_{OS}	Input offset current			± 0.2	± 10	μA
NOISE						
e_n	Input voltage noise	$f = 0.1\text{ Hz}$ to 10 Hz		5		μV_{PP}
e_n	Input voltage noise density	$f = 100\text{ kHz}$		4.5		$\text{nV}/\sqrt{\text{Hz}}$
i_n	Input current noise density	$f = 10\text{ kHz}$		4		$\text{fA}/\sqrt{\text{Hz}}$
INPUT VOLTAGE RANGE						
V_{CM}	Common-mode voltage range		$(V_-) - 0.1$		$(V_+) + 0.1$	V
CMRR	Common-mode rejection ratio	$(V_-) - 0.1\text{ V} \leq V_{CM} \leq (V_+) + 0.1\text{ V}$, at $T_A = -40^\circ\text{C}$ to $+125^\circ\text{C}$	100	120		dB
INPUT CAPACITANCE						
	Differential			6		pF
	Common-mode			2		pF
OPEN-LOOP GAIN						
A_{OL}	Open-loop voltage gain	$R_L = 10\text{ k}\Omega$, $100\text{ mV} < V_O < (V_+) - 100\text{ mV}$, at $T_A = -40^\circ\text{C}$ to $+125^\circ\text{C}$	100	120		dB
		$R_L = 600\ \Omega$, $200\text{ mV} < V_O < (V_+) - 200\text{ mV}$	100	120		dB
		$R_L = 600\ \Omega$, $200\text{ mV} < V_O < (V_+) - 200\text{ mV}$, at $T_A = -40^\circ\text{C}$ to $+125^\circ\text{C}$	94			dB
FREQUENCY RESPONSE						
GBW	Gain-bandwidth product	$V_S = 5\text{ V}$		50		MHz
SR	Slew rate	$V_S = 5\text{ V}$, $G = 1$		25		$\text{V}/\mu\text{s}$
t_S	Settling time	0.1%	$V_S = 5\text{ V}$, 4-V step, $G = +1$	200		ns
		0.01%	$V_S = 5\text{ V}$, 4-V step, $G = +1$	300		ns

Electrical Characteristics (continued)

 At $T_A = 25^\circ\text{C}$, $R_L = 10\text{ k}\Omega$ connected to $V_S/2$, $V_{CM} = V_S/2$, and $V_{OUT} = V_S/2$, unless otherwise noted.

PARAMETER		TEST CONDITIONS	MIN	TYP	MAX	UNIT
Overload recovery time		$V_S = 5\text{ V}$, $V_{IN} \times \text{Gain} > V_S$		< 0.1		μs
THD+N	Total harmonic distortion + noise ⁽¹⁾	$V_S = 5\text{ V}$, $R_L = 600\ \Omega$, $V_O = 4\text{ V}_{PP}$, $G = 1$, $f = 1\text{ kHz}$		0.0004%		
OUTPUT						
Voltage output swing from rail		$R_L = 10\text{ k}\Omega$, $V_S = 5.5\text{ V}$, at $T_A = -40^\circ\text{C}$ to $+125^\circ\text{C}$		10	20	mV
I_{SC}	Short-circuit current			± 65		mA
C_L	Capacitive load drive			See Typical Characteristics		
Open-loop output impedance		$f = 1\text{ MHz}$, $I_O = 0\text{ mA}$		30		Ω
POWER SUPPLY						
V_S	Specified voltage range		2.2		5.5	V
I_Q	Quiescent current per amplifier			4.6	5	mA
		Over temperature	At $T_A = -40^\circ\text{C}$ to $+125^\circ\text{C}$		5	

 (1) 3rd-order filter; bandwidth 80 kHz at -3 dB .

6.7 Typical Characteristics

At $T_A = 25^\circ\text{C}$, $V_S = 5\text{ V}$, and $C_L = 0\text{ pF}$, unless otherwise noted.

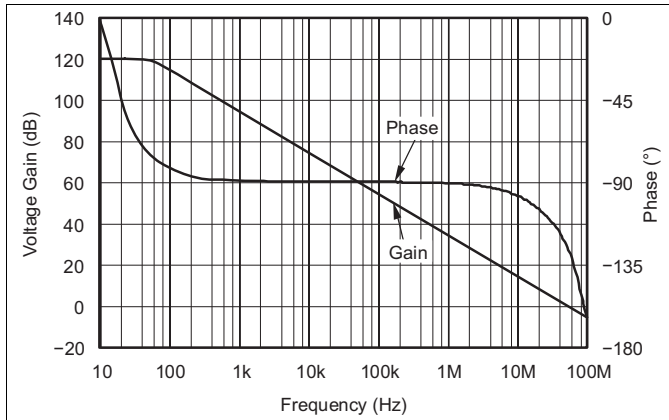

Figure 1. Open-Loop Gain and Phase vs Frequency

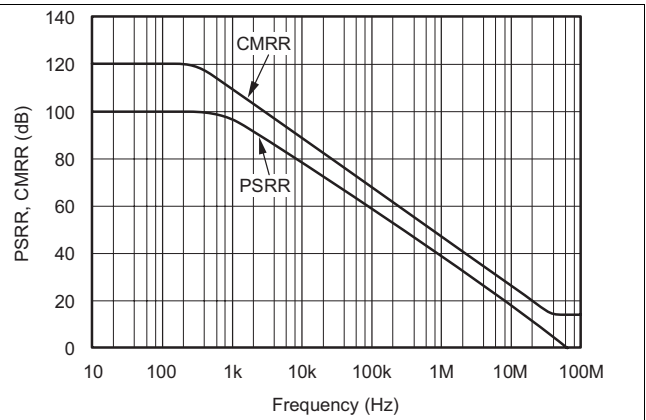

Figure 2. Power-Supply and Common-Mode Rejection Ratio vs Frequency

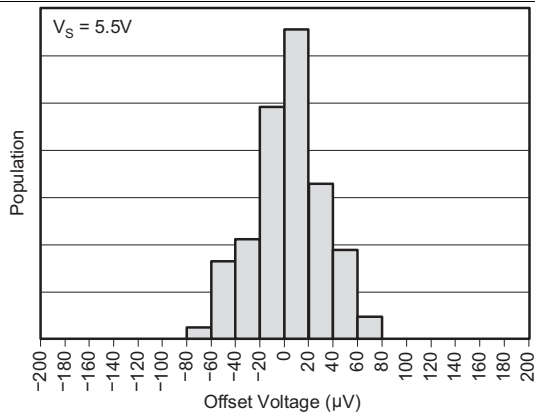

Figure 3. Offset Voltage Production Distribution

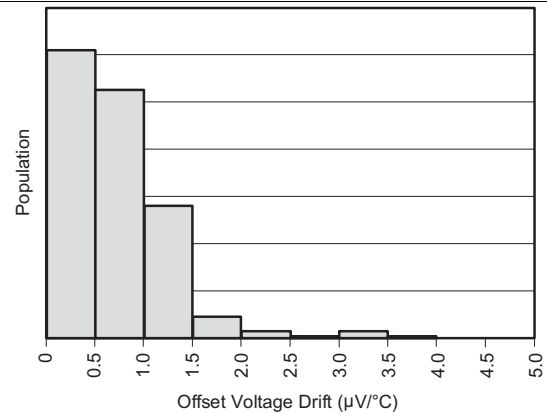

Figure 4. Offset Voltage Drift Production Distribution

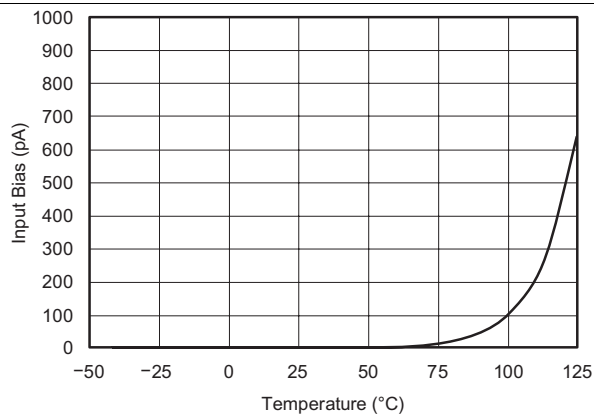

Figure 5. Input Bias Current vs Temperature

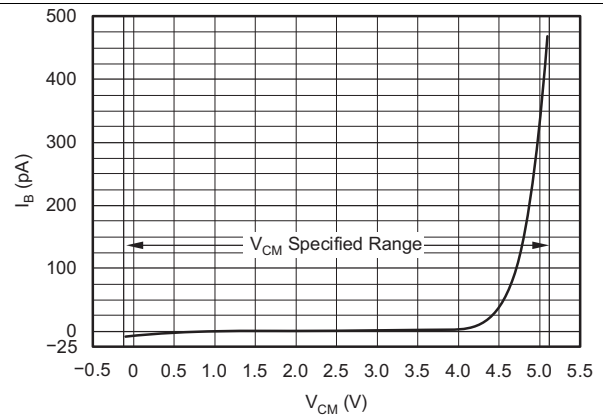

Figure 6. Input Bias Current vs Common-Mode Voltage

Typical Characteristics (continued)

At $T_A = 25^\circ\text{C}$, $V_S = 5\text{ V}$, and $C_L = 0\text{ pF}$, unless otherwise noted.

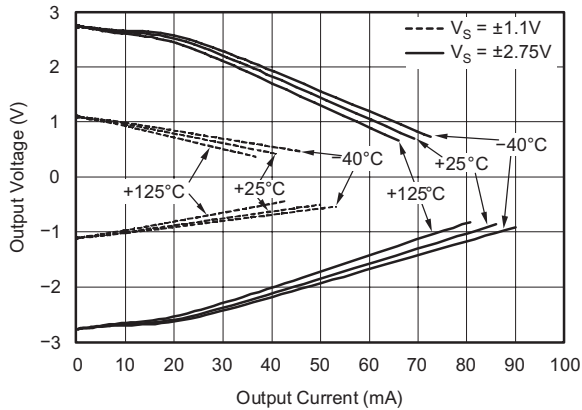

Figure 7. OPA365 Output Voltage vs Output Current

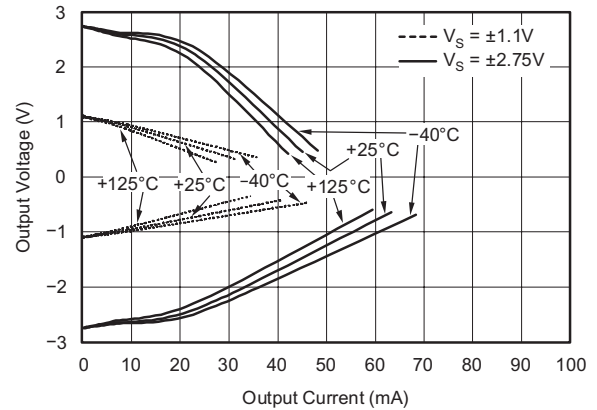

Figure 8. OPA2365 Output Voltage vs Output Current

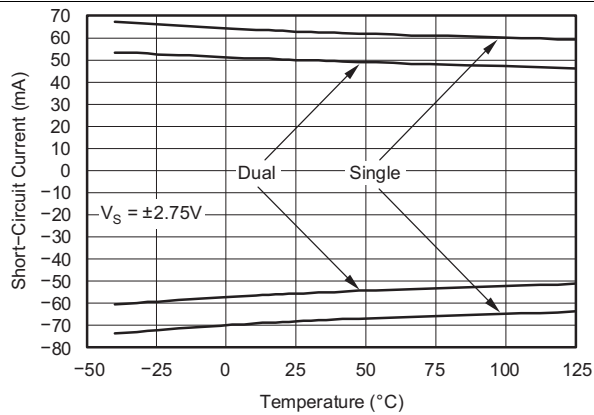

Figure 9. Short-Circuit Current vs Temperature

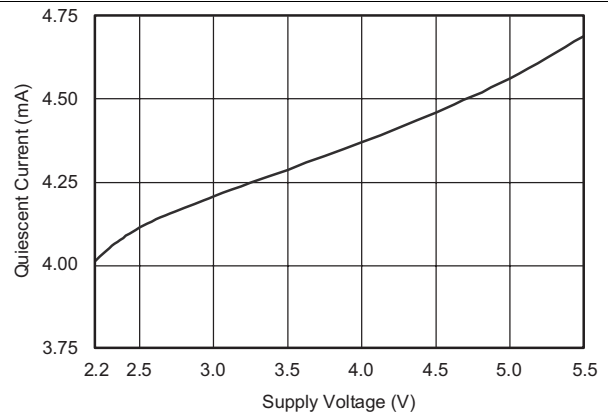

Figure 10. Quiescent Current vs Supply Voltage

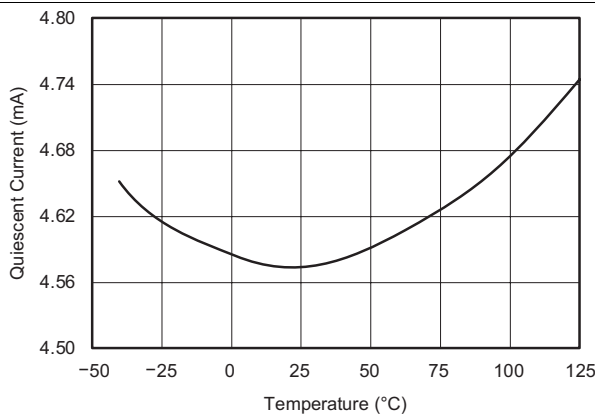

Figure 11. Quiescent Current vs Temperature

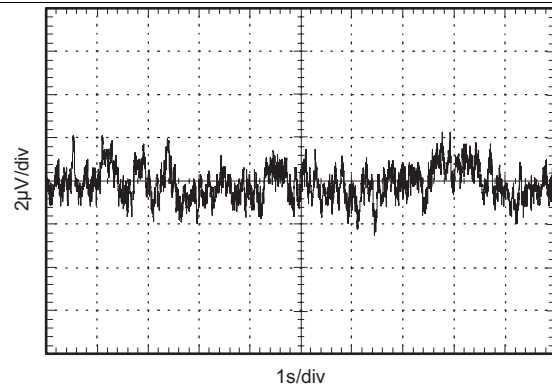

Figure 12. 0.1-Hz to 10-Hz Input Voltage Noise

Typical Characteristics (continued)

At $T_A = 25^\circ\text{C}$, $V_S = 5\text{ V}$, and $C_L = 0\text{ pF}$, unless otherwise noted.

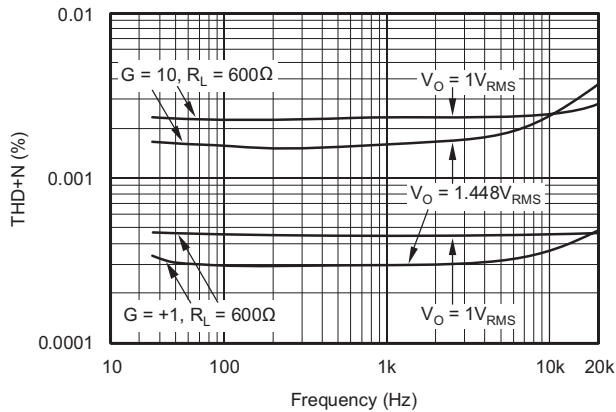

Figure 13. Total Harmonic Distortion + Noise vs Frequency

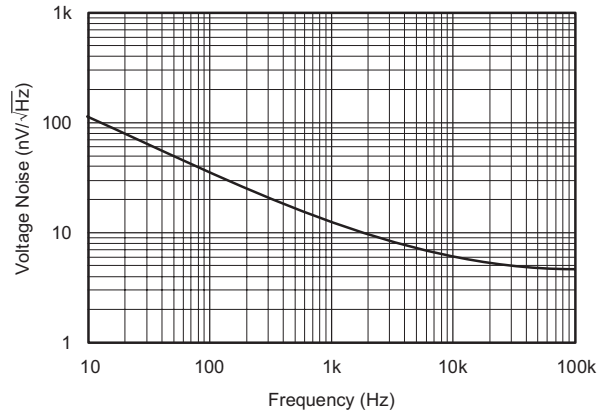

Figure 14. Input Voltage Noise Spectral Density

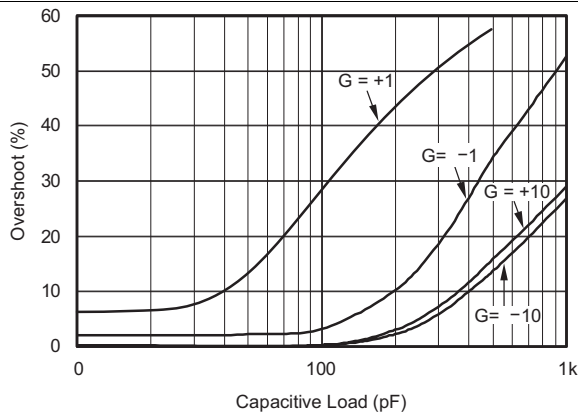

Figure 15. Overshoot vs Capacitive Load

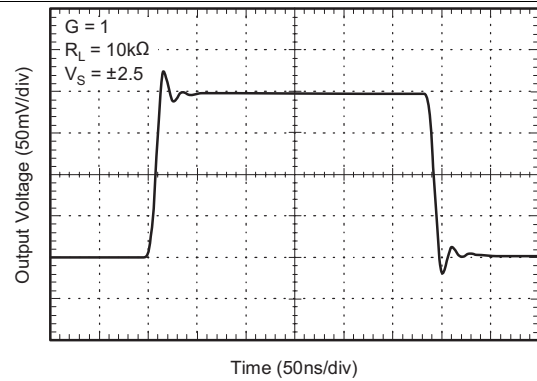

Figure 16. Small-Signal Step Response

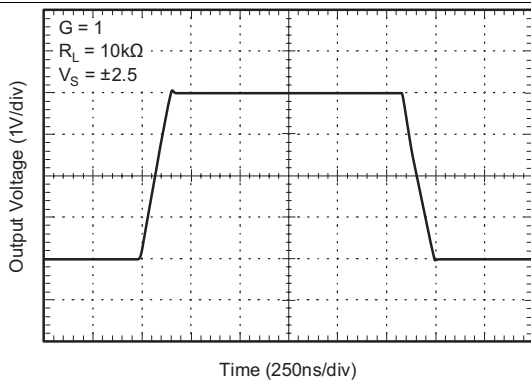

Figure 17. Large-Signal Step Response

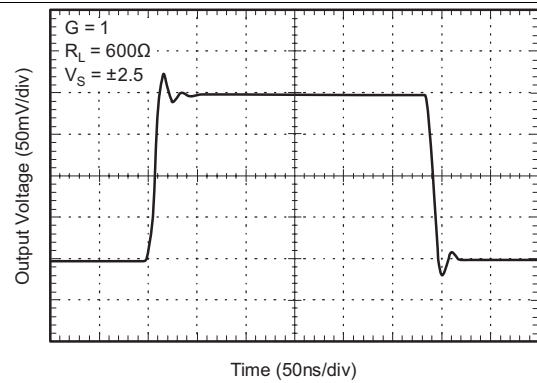
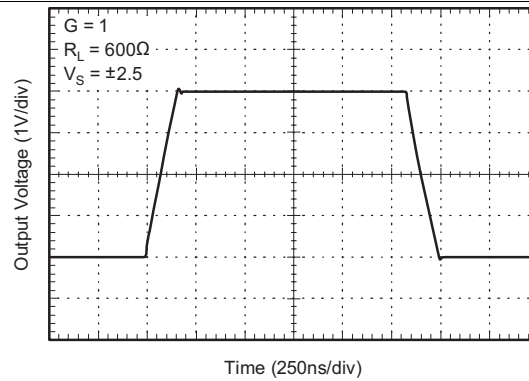

Figure 18. Small-Signal Step Response

Typical Characteristics (continued)

 At $T_A = 25^\circ\text{C}$, $V_S = 5\text{ V}$, and $C_L = 0\text{ pF}$, unless otherwise noted.

Figure 19. Large-Signal Step Response

7 Detailed Description

7.1 Overview

The OPAx365 series of operational amplifiers feature rail-to-rail, high performance that make these devices an excellent choice for driving ADCs. Other typical applications include signal conditioning, cell phone power amplifier control loops, audio, and sensor amplification. The OPAx365 is a wideband amplifier that may be operated with either a single supply or dual supplies.

Furthermore, the OPA365 amplifier parameters are fully specified from 2.2 V to 5.5 V. Many of the specifications apply from -40°C to $+125^{\circ}\text{C}$. Parameters that can exhibit significant variance with regard to operating voltage or temperature are presented in the *Typical Characteristics*.

7.2 Functional Block Diagram

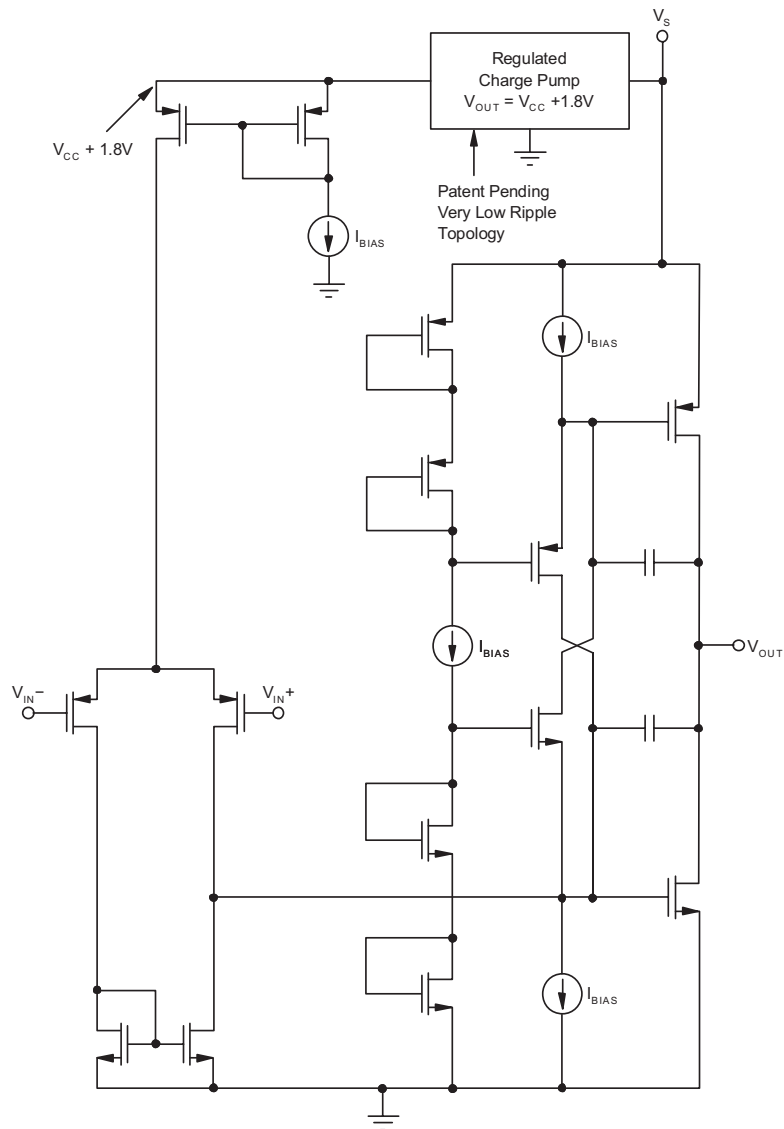

Copyright © 2016, Texas Instruments Incorporated

7.3 Feature Description

7.3.1 Rail-to-Rail Input

The OPA365 product family features true rail-to-rail input operation, with supply voltages as low as ± 1.1 V (2.2 V). A unique zero-crossover input topology eliminates the input offset transition region typical of many rail-to-rail, complementary stage operational amplifiers. This topology also allows the OPA365 to provide superior common-mode performance over the entire input range, which extends 100 mV beyond both power-supply rails, as shown in Figure 20. When driving ADCs, the highly linear V_{CM} range of the OPA365 assures that the op amp or ADC system linearity performance is not compromised.

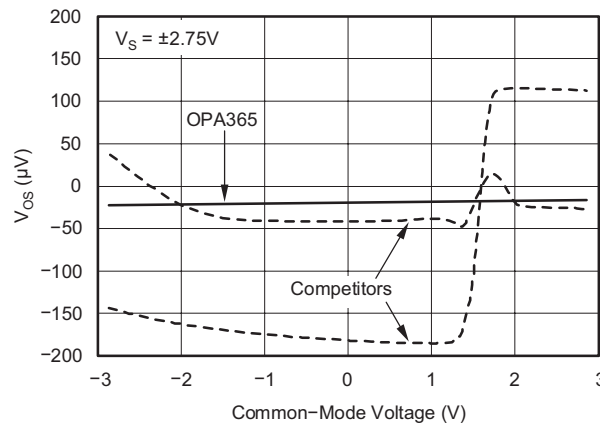
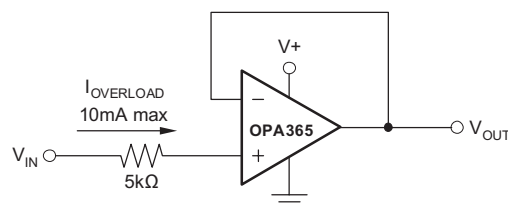

Figure 20. OPA365 Linear Offset Over the Entire Common-Mode Range

A simplified schematic illustrating the rail-to-rail input circuitry is shown in the [Functional Block Diagram](#).

7.3.2 Input and ESD Protection

The OPA365 incorporates internal electrostatic discharge (ESD) protection circuits on all pins. In the case of input and output pins, this protection primarily consists of current steering diodes connected between the input and power-supply pins. These ESD protection diodes also provide in-circuit, input overdrive protection, provided that the current is limited to 10 mA as stated in the [Absolute Maximum Ratings](#). Figure 21 shows how a series input resistor may be added to the driven input to limit the input current. The added resistor contributes thermal noise at the amplifier input and its value must be kept to the minimum in noise-sensitive applications.



Copyright © 2016, Texas Instruments Incorporated

Figure 21. Input Current Protection

7.3.3 Capacitive Loads

The OPA365 may be used in applications where driving a capacitive load is required. As with all op amps, there may be specific instances where the OPA365 can become unstable, leading to oscillation. The particular op amp circuit configuration, layout, gain, and output loading are some of the factors to consider when establishing whether an amplifier will be stable in operation. An op amp in the unity-gain ($+1 - V/V$) buffer configuration and driving a capacitive load exhibits a greater tendency to be unstable than an amplifier operated at a higher noise gain. The capacitive load, in conjunction with the op amp output resistance, creates a pole within the feedback loop that degrades the phase margin. The degradation of the phase margin increases as the capacitive loading increases.

Feature Description (continued)

When operating in the unity-gain configuration, the OPA365 remains stable with a pure capacitive load up to approximately 1 nF. The equivalent series resistance (ESR) of some very large capacitors ($C_L > 1 \mu\text{F}$) is sufficient to alter the phase characteristics in the feedback loop such that the amplifier remains stable. Increasing the amplifier closed-loop gain allows the amplifier to drive increasingly larger capacitance. This increased capability is evident when observing the overshoot response of the amplifier at higher voltage gains. See [Figure 15](#).

One technique for increasing the capacitive load drive capability of the amplifier operating in unity gain is to insert a small resistor, typically 10Ω to 20Ω , in series with the output; see [Figure 22](#). This resistor significantly reduces the overshoot and ringing associated with large capacitive loads. A possible problem with this technique is that a voltage divider is created with the added series resistor and any resistor connected in parallel with the capacitive load. The voltage divider introduces a gain error at the output that reduces the output swing. The error contributed by the voltage divider may be insignificant. For instance, with a load resistance, $R_L = 10 \text{ k}\Omega$, and $R_S = 20 \Omega$, the gain error is only about 0.2%. However, when R_L is decreased to 600Ω , which the OPA365 is able to drive, the error increases to 7.5%.

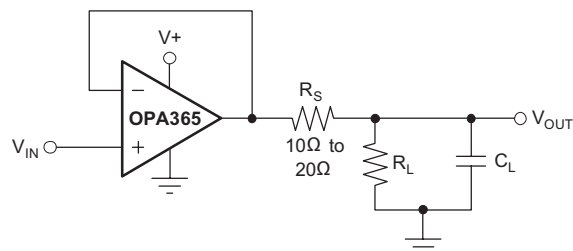

Copyright © 2016, Texas Instruments Incorporated

Figure 22. Improving Capacitive Load Drive

7.3.4 Achieving an Output Level of Zero Volts (0 V)

Certain single-supply applications require the op amp output to swing from 0 V to a positive full-scale voltage and have high accuracy. An example is an op amp employed to drive a single-supply ADC having an input range from 0 V to 5 V. Rail-to-rail output amplifiers with very light output loading may achieve an output level within millivolts of 0 V (or $+V_S$ at the high end), but not 0 V. Furthermore, the deviation from 0 V only becomes greater as the load current required increases. This increased deviation is a result of limitations of the CMOS output stage.

When a pull-down resistor is connected from the amplifier output to a negative voltage source, the OPA365 can achieve an output level of 0 V, and even a few millivolts below 0 V. Below this limit, nonlinearity and limiting conditions become evident. [Figure 23](#) illustrates a circuit using this technique.

A pull-down current of approximately $500 \mu\text{A}$ is required when OPA365 is connected as a unity-gain buffer. A practical termination voltage (V_{NEG}) is -5 V , but other convenient negative voltages also may be used. The pull-down resistor R_L is calculated from $R_L = [(V_O - V_{\text{NEG}}) / (500 \mu\text{A})]$.

Using a minimum output voltage (V_O) of 0 V, $R_L = [0 \text{ V} - (-5 \text{ V})] / (500 \mu\text{A}) = 10 \text{ k}\Omega$. Keep in mind that lower termination voltages result in smaller pull-down resistors that load the output during positive output voltage excursions.

NOTE

This technique does not work with all op amps and should only be applied to op amps such as the OPA365 that have been specifically designed to operate in this manner. Also, operating the OPA365 output at 0 V changes the output stage operating conditions, resulting in somewhat lower open-loop gain and bandwidth.

Keep these precautions in mind when driving a capacitive load because these conditions can affect circuit transient response and stability.

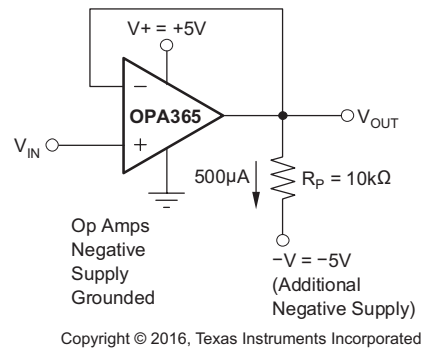
Feature Description (continued)

Figure 23. Swing-to-Ground
7.3.5 Active Filtering

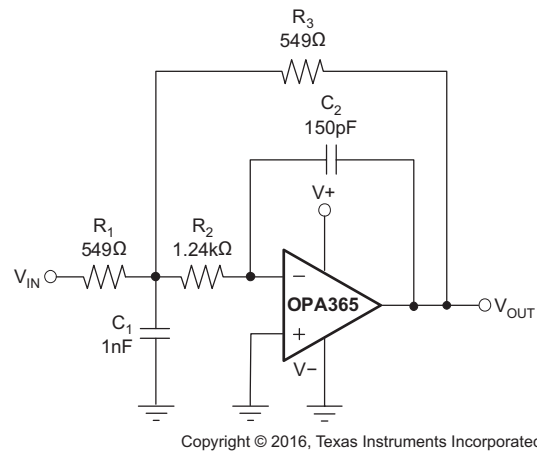
The OPA365 is well-suited for active filter applications requiring a wide bandwidth, fast slew rate, low-noise, single-supply operational amplifier. [Figure 24](#) shows a 500-kHz, second-order, low-pass filter utilizing the multiple-feedback (MFB) topology. The components have been selected to provide a maximally-flat Butterworth response. Beyond the cutoff frequency, roll-off is -40 dB/dec. The Butterworth response is ideal for applications requiring predictable gain characteristics such as the anti-aliasing filter used ahead of an ADC.

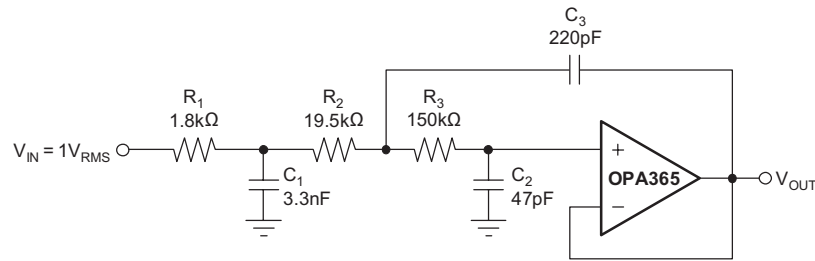

Figure 24. Second-Order Butterworth, 500-kHz Low-Pass Filter

One point to observe when considering the MFB filter is that the output is inverted, relative to the input. If this inversion is not required, or not desired, a noninverting output can be achieved through one of these options:

- adding an inverting amplifier;
- adding an additional second-order MFB stage; or
- using a noninverting filter topology such as the Sallen-Key.

The Sallen-Key topology is shown in [Figure 25](#).

Feature Description (continued)



Copyright © 2016, Texas Instruments Incorporated

Figure 25. Configured as a Three-Pole, 20-kHz, Sallen-Key Filter

7.4 Device Functional Modes

The OPA365 family has a single functional mode and are operational when the power-supply voltage is greater than 2.2 V (± 1.1 V). The maximum power supply voltage for the OPA365 family is 5.5 V (± 2.75 V).

8 Application and Implementation

NOTE

Information in the following applications sections is not part of the TI component specification, and TI does not warrant its accuracy or completeness. TI's customers are responsible for determining suitability of components for their purposes. Customers should validate and test their design implementation to confirm system functionality.

8.1 Application Information

8.1.1 Basic Amplifier Configurations

As with other single-supply op amps, the OPA365 may be operated with either a single supply or dual supplies. A typical dual-supply connection is shown in Figure 26, which is accompanied by a single-supply connection. The OPA365 is configured as a basic inverting amplifier with a gain of -10 V/V. The dual-supply connection has an output voltage centered on zero, while the single-supply connection has an output centered on the common-mode voltage V_{CM} . For the circuit shown, this voltage is 1.5 V, but may be any value within the common-mode input voltage range. The OPA365 V_{CM} range extends 100 mV beyond the power-supply rails.

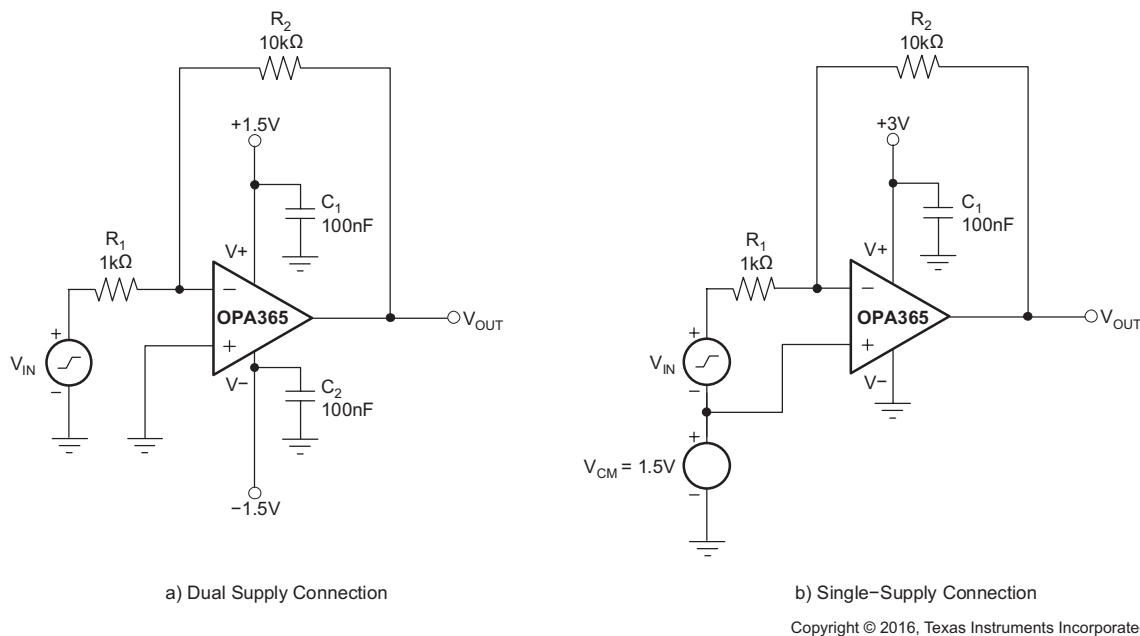
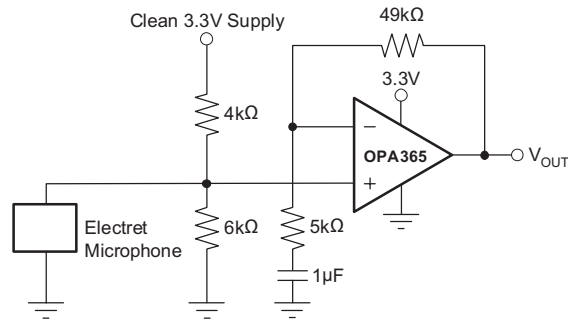

Figure 26. Basic Circuit Connections

Figure 27 shows a single-supply, electret microphone application where V_{CM} is provided by a resistive divider. The divider also provides the bias voltage for the electret element.

Application Information (continued)



Copyright © 2016, Texas Instruments Incorporated

Figure 27. Microphone Preampfier

8.2 Typical Application

Low-pass filters are commonly employed in signal processing applications to reduce noise and prevent aliasing. The OPA365 is ideally suited to construct high-speed, high-precision active filters. Figure 28 illustrates a second-order low-pass filter commonly encountered in signal processing applications.

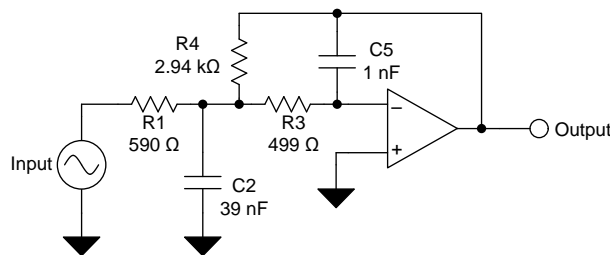

Copyright © 2016, Texas Instruments Incorporated

Figure 28. Second-Order Low-Pass Filter

8.2.1 Design Requirements

Use the following parameters for this design example:

- Gain = 5 V/V (inverting gain)
- Low-pass cutoff frequency = 25 kHz
- Second-order Chebyshev filter response with 3-dB gain peaking in the passband

8.2.2 Detailed Design Procedure

The infinite-gain multiple-feedback circuit for a low-pass network function is shown in Figure 28. Use Equation 1 to calculate the voltage transfer function.

$$\frac{\text{Output}}{\text{Input}}(s) = \frac{-1/R_1 R_3 C_2 C_5}{s^2 + (s/C_2)(1/R_1 + 1/R_3 + 1/R_4) + 1/R_3 R_4 C_2 C_5} \quad (1)$$

This circuit produces a signal inversion. For this circuit the gain at DC and the low-pass cutoff frequency can be calculated using Equation 2.

$$\text{Gain} = \frac{R_4}{R_1}$$

$$f_c = \frac{1}{2\pi} \sqrt{1/R_3 R_4 C_2 C_5} \quad (2)$$

Typical Application (continued)

Software tools are readily available to simplify filter design. [WEBENCH® Filter Designer](#) is a simple, powerful, and easy-to-use active filter design program. The WEBENCH® Filter Designer lets you create optimized filter designs using a selection of TI operational amplifiers and passive components from TI's vendor partners. Available as a web based tool from the WEBENCH Design Center, WEBENCH Filter Designer allows you to design, optimize, and simulate complete multi-stage active filter solutions within minutes.

8.2.3 Application Curve

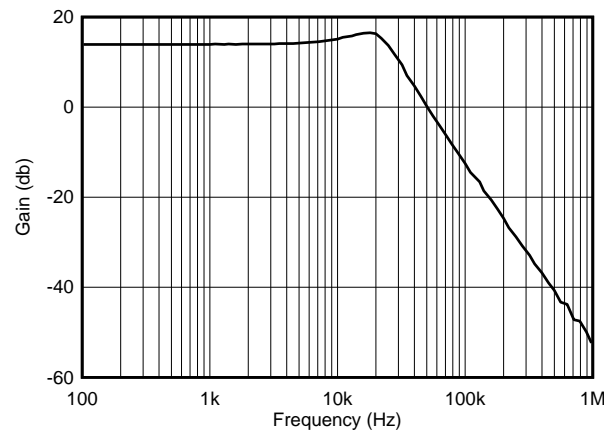

Figure 29. OPA365 Second-Order 25 kHz, Chebyshev, Low-Pass Filter

8.3 System Examples

8.3.1 Driving an Analog-to-Digital Converter

Very wide common-mode input range, rail-to-rail input and output voltage capability, and high speed make the OPA365 an ideal driver for modern ADCs. Also, because it is free of the input offset transition characteristics inherent to some rail-to-rail CMOS op amps, the OPA365 provides low THD and excellent linearity throughout the input voltage swing range.

[Figure 30](#) shows the OPA365 driving an ADS8326, 16-bit, 250-kSPS converter. The amplifier is connected as a unity-gain, noninverting buffer and has an output swing to 0 V, making it directly compatible with the ADC minus full-scale input level. The 0-V level is achieved by powering the OPA365 V- pin with a small negative voltage established by the diode forward voltage drop. A small, signal-switching diode or Schottky diode provides a suitable negative supply voltage of -0.3 V to -0.7 V. The supply rail-to-rail is equal to V+, plus the small negative voltage.

System Examples (continued)

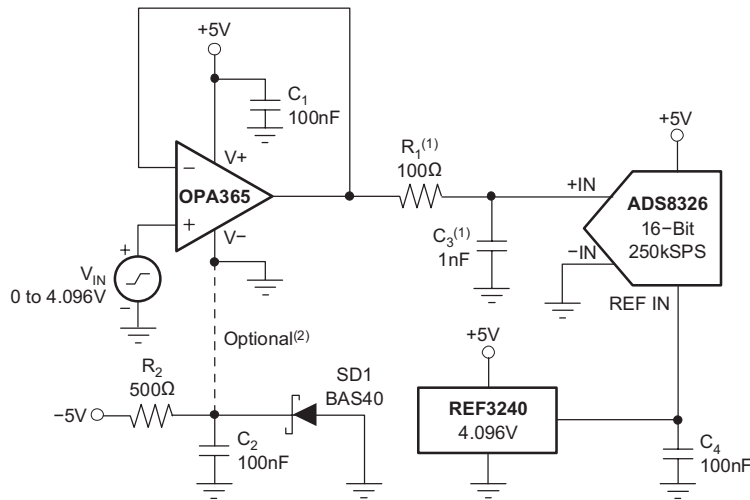

Copyright © 2016, Texas Instruments Incorporated

- (1) Suggested value; may require adjustment based on specific application.
- (2) Single-supply applications lose a small number of ADC codes near ground due to op amp output swing limitation. If a negative power supply is available, this simple circuit creates a -0.3-V supply to allow output swing to true ground potential.

Figure 30. Driving the ADS8326

One method for driving an ADC that negates the need for an output swing down to 0 V uses a slightly compressed ADC full-scale input range (FSR). For example, the 16-bit ADS8361 (shown in Figure 31) has a maximum FSR of 0 V to 5 V, when powered by a 5-V supply and V_{REF} of 2.5 V. The idea is to match the ADC input range with the op amp full linear output swing range; for example, an output range of 0.1 V to 4.9 V. The reference output from the ADS8361 ADC is divided down from 2.5 V to 2.4 V using a resistive divider. The ADC FSR then becomes 4.8 V_{PP} centered on a common-mode voltage of 2.5 V. Current from the ADS8361 reference pin is limited to approximately $\pm 10\ \mu\text{A}$. Here, 5 μA was used to bias the divider. The resistors must be precise to maintain the ADC gain accuracy. An additional benefit of this method is the elimination of the negative supply voltage; it requires no additional power-supply current.

An RC network, consisting of R_1 and C_1 , is included between the op amp and the ADS8361. It not only provides a high-frequency filter function, but more importantly serves as a charge reservoir used for charging the converter internal hold capacitance. This capability assures that the op amp output linearity is maintained as the ADC input characteristics change throughout the conversion cycle. Depending on the particular application and ADC, some optimization of the R_1 and C_1 values may be required for best transient performance.

System Examples (continued)

Figure 31. Driving the ADS8361

Figure 32 illustrates the OPA2365 dual op amp providing signal conditioning within an ADS1258 bridge sensor circuit. It follows the ADS1258 16:1 multiplexer and is connected as a differential in or differential out amplifier. The voltage gain for this stage is approximately 10 V/V. Driving the ADS1258 internal ADC in differential mode, rather than in a single-ended, exploits the full linearity performance capability of the converter. For best common-mode rejection, the two R_2 resistors should be closely matched.

Note that in **Figure 32**, the amplifiers, bridges, ADS1258, and internal reference are powered by the same single 5-V supply. This ratiometric connection helps cancel excitation voltage drift effects and noise. For best performance, the 5-V supply must be as free as possible of noise and transients.

When the ADS1258 data rate is set to maximum and the chop feature enabled, this circuit yields 12 bits of noise-free resolution with a 50-mV full-scale input.

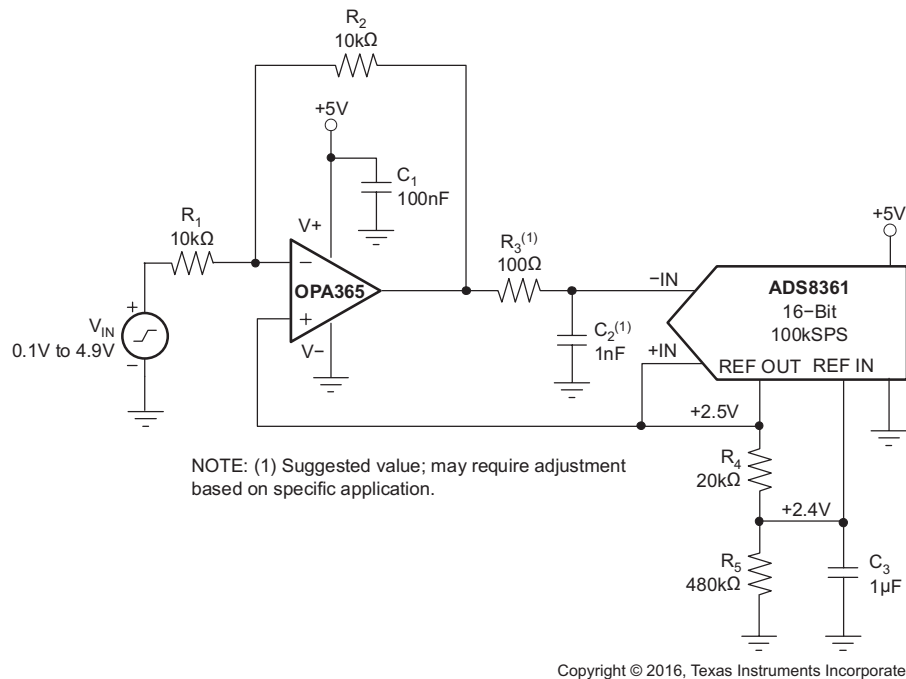
The chop feature is used to reduce the ADS1258 offset and offset drift to very low levels. A 2.2-nF capacitor is required across the ADC inputs to bypass the sampling currents. The 47-Ω resistors provide isolation for the OPA2365 outputs from the relatively large, 2.2-nF capacitive load. For more information regarding the ADS1258, see the [product data sheet available for download](http://www.ti.com) at www.ti.com.

System Examples (continued)

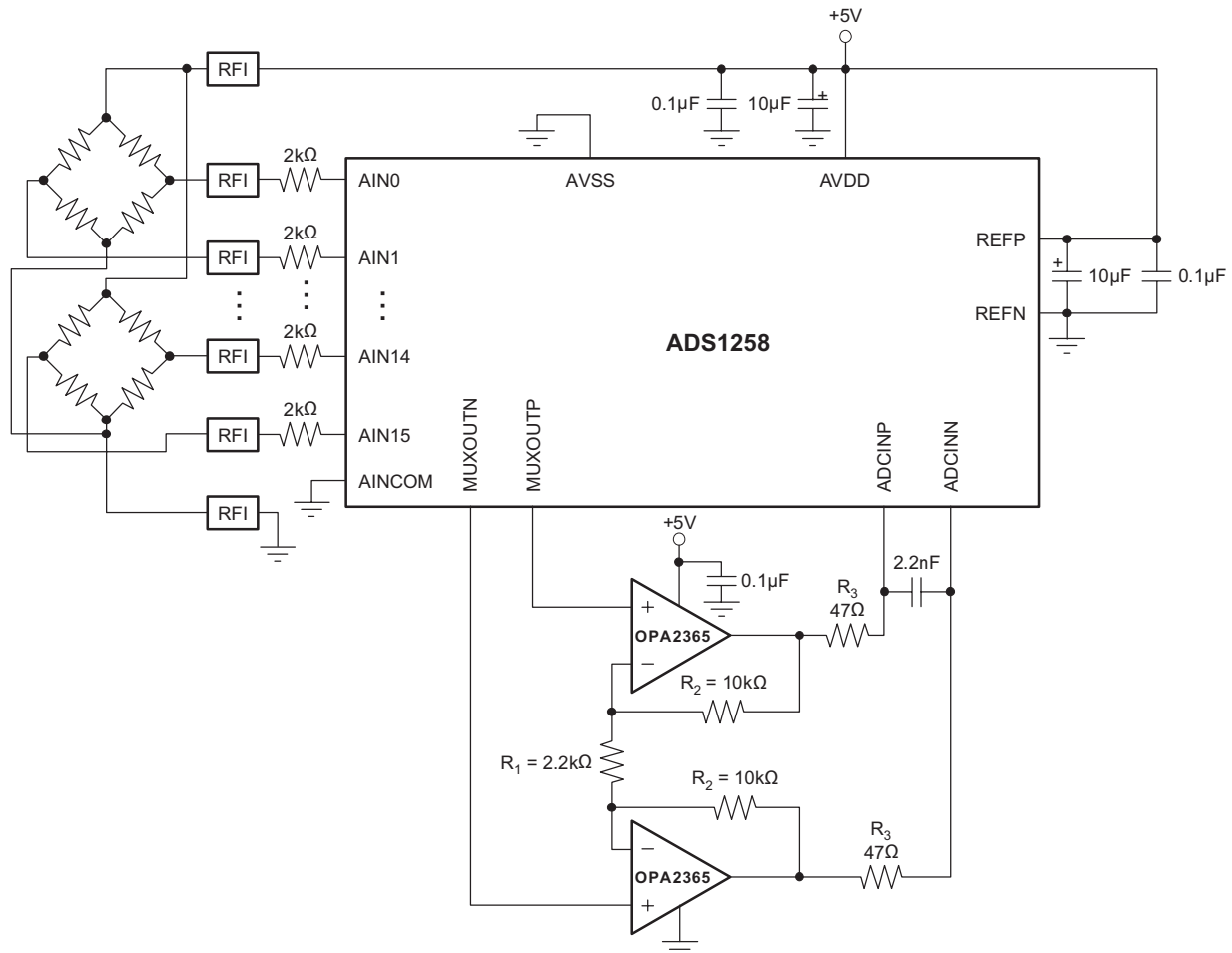

NOTE: $G = 1 + 2R_2/R_1$. Match R_2 resistors for optimum CMRR.

Copyright © 2016, Texas Instruments Incorporated

Figure 32. Conditioning Input Signals to the ADS1258 on a Single Supply

9 Power Supply Recommendations

The OPA365 family is specified for operation from 2.2 V to 5.5 V (± 1.1 V to ± 2.75 V); many specifications apply from -40°C to 125°C . Parameters that can exhibit significant variance with regard to operating voltage or temperature are presented in the *Typical Characteristics*.

10 Layout

10.1 Layout Guidelines

For best operational performance of the device, use good PCB layout practices, including:

- Noise can propagate into analog circuitry through the power pins of the circuit as a whole and operational amplifier itself. Bypass capacitors are used to reduce the coupled noise by providing low-impedance power sources local to the analog circuitry.
 - Connect low-ESR, 0.1- μF ceramic bypass capacitors between each supply pin and ground, placed as close to the device as possible. A single bypass capacitor from V+ to ground is applicable for single-supply applications.
 - The OPA365 is capable of high-output current (in excess of 65 mA). Applications with low impedance

Layout Guidelines (continued)

loads or capacitive loads with fast transient signals demand large currents from the power supplies. Larger bypass capacitors such as 1- μ F solid tantalum capacitors may improve dynamic performance in these applications.

- Separate grounding for analog and digital portions of circuitry is one of the simplest and most-effective methods of noise suppression. One or more layers on multilayer PCBs are usually devoted to ground planes. A ground plane helps distribute heat and reduces EMI noise pickup. Make sure to physically separate digital and analog grounds paying attention to the flow of the ground current. For more detailed information refer to [Circuit Board Layout Techniques](#) (SLOA089).
- To reduce parasitic coupling, run the input traces as far away from the supply or output traces as possible. If these traces cannot be kept separate, crossing the sensitive trace perpendicular is much better as opposed to in parallel with the noisy trace.
- Place the external components as close to the device as possible. As shown in [Figure 33](#), keeping RF and RG close to the inverting input minimizes parasitic capacitance.
- Keep the length of input traces as short as possible. Always remember that the input traces are the most sensitive part of the circuit.
- Consider a driven, low-impedance guard ring around the critical traces. A guard ring can significantly reduce leakage currents from nearby traces that are at different potentials.
- Cleaning the PCB following board assembly is recommended for best performance.
- Any precision integrated circuit may experience performance shifts due to moisture ingress into the plastic package. Following any aqueous PCB cleaning process, baking the PCB assembly is recommended to remove moisture introduced into the device packaging during the cleaning process. A low temperature, post cleaning bake at 85°C for 30 minutes is sufficient for most circumstances.

10.2 Layout Example

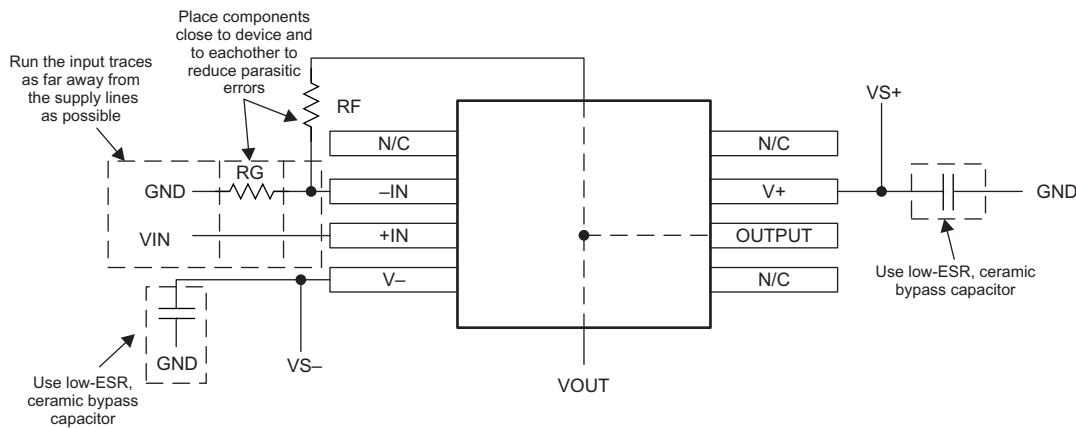

Copyright © 2016, Texas Instruments Incorporated

Figure 33. Layout Recommendation

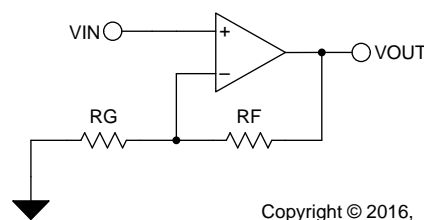

Copyright © 2016, Texas Instruments Incorporated

Figure 34. Schematic Representation

11 Device and Documentation Support

11.1 Device Support

11.1.1 Development Support

11.1.1.1 TINA-TI™ (Free Software Download)

TINA™ is a simple, powerful, and easy-to-use circuit simulation program based on a SPICE engine. TINA-TI™ is a free, fully-functional version of the TINA software, preloaded with a library of macro models in addition to a range of both passive and active models. TINA-TI provides all the conventional dc, transient, and frequency domain analysis of SPICE, as well as additional design capabilities.

Available as a [free download](#) from the Analog eLab Design Center, TINA-TI offers extensive post-processing capability that allows users to format results in a variety of ways. Virtual instruments offer the ability to select input waveforms and probe circuit nodes, voltages, and waveforms, creating a dynamic quick-start tool.

NOTE

These files require that either the TINA software (from DesignSoft™) or TINA-TI software be installed. Download the free TINA-TI software from the [TINA-TI folder](#).

11.1.1.2 DIP Adapter EVM

The [DIP Adapter EVM](#) tool provides an easy, low-cost way to prototype small surface mount ICs. The evaluation tool these TI packages: D or U (SOIC-8), PW (TSSOP-8), DGK (MSOP-8), DBV (SOT23-6, SOT23-5 and SOT23-3), DCK (SC70-6 and SC70-5), and DRL (SOT563-6). The DIP Adapter EVM may also be used with terminal strips or may be wired directly to existing circuits.

11.1.1.3 Universal Op Amp EVM

The [Universal Op Amp EVM](#) is a series of general-purpose, blank circuit boards that simplify prototyping circuits for a variety of IC package types. The evaluation module board design allows many different circuits to be constructed easily and quickly. Five models are offered, with each model intended for a specific package type. PDIP, SOIC, MSOP, TSSOP and SOT23 packages are all supported.

NOTE

These boards are unpopulated, so users must provide their own ICs. TI recommends requesting several op amp device samples when ordering the Universal Op Amp EVM.

11.1.1.4 TI Precision Designs

TI Precision Designs are analog solutions created by TI's precision analog applications experts and offer the theory of operation, component selection, simulation, complete PCB schematic and layout, bill of materials, and measured performance of many useful circuits. TI Precision Designs are available online at <http://www.ti.com/ww/en/analog/precision-designs/>.

11.1.1.5 WEBENCH® Filter Designer

[WEBENCH® Filter Designer](#) is a simple, powerful, and easy-to-use active filter design program. The WEBENCH Filter Designer lets you create optimized filter designs using a selection of TI operational amplifiers and passive components from TI's vendor partners.

Available as a web-based tool from the WEBENCH® Design Center, [WEBENCH® Filter Designer](#) allows you to design, optimize, and simulate complete multistage active filter solutions within minutes.

11.2 Documentation Support

11.2.1 Related Documentation

The following documents are relevant to using the OPAx365, and recommended for reference. All are available for download at www.ti.com unless otherwise noted.

- User guide: *FilterPro™ MFB and Sallen-Key Low-Pass Filter Design Program User Guide* (SBFA001)
- Application report: *Low Power Input and Reference Driver Circuit for ADS8318 and ADS8319* (SBOA118)
- Application bulletin AB-045: *Op Amp Performance Analysis* (SBOA054)
- Application bulletin AB-067: *Single-Supply Operation of Operational Amplifiers* (SBOA059)
- Application bulletin AB-105: *Tuning in Amplifiers* (SBOA067)
- Reference book: *The Best of Baker's Best – Amplifiers eBook* (SLYC124)

11.3 Related Links

Table 1 lists quick access links. Categories include technical documents, support and community resources, tools and software, and quick access to sample or buy.

Table 1. Related Links

PARTS	PRODUCT FOLDER	SAMPLE & BUY	TECHNICAL DOCUMENTS	TOOLS & SOFTWARE	SUPPORT & COMMUNITY
OPA365	Click here	Click here	Click here	Click here	Click here
OPA2365	Click here	Click here	Click here	Click here	Click here

11.4 Community Resources

The following links connect to TI community resources. Linked contents are provided "AS IS" by the respective contributors. They do not constitute TI specifications and do not necessarily reflect TI's views; see TI's [Terms of Use](#).

TI E2E™ Online Community *TI's Engineer-to-Engineer (E2E) Community*. Created to foster collaboration among engineers. At e2e.ti.com, you can ask questions, share knowledge, explore ideas and help solve problems with fellow engineers.

Design Support *TI's Design Support* Quickly find helpful E2E forums along with design support tools and contact information for technical support.

11.5 Trademarks

TINA-TI, E2E are trademarks of Texas Instruments.
 WEBENCH is a registered trademark of Texas Instruments.
 TINA, DesignSoft are trademarks of DesignSoft, Inc.
 All other trademarks are the property of their respective owners.

11.6 Electrostatic Discharge Caution



These devices have limited built-in ESD protection. The leads should be shorted together or the device placed in conductive foam during storage or handling to prevent electrostatic damage to the MOS gates.

11.7 Glossary

SLYZ022 — *TI Glossary*.

This glossary lists and explains terms, acronyms, and definitions.

12 Mechanical, Packaging, and Orderable Information

The following pages include mechanical, packaging, and orderable information. This information is the most current data available for the designated devices. This data is subject to change without notice and revision of this document. For browser-based versions of this data sheet, refer to the left-hand navigation.

PACKAGING INFORMATION

Orderable Device	Status (1)	Package Type	Package Drawing	Pins	Package Qty	Eco Plan (2)	Lead/Ball Finish (6)	MSL Peak Temp (3)	Op Temp (°C)	Device Marking (4/5)	Samples
OPA2365AID	ACTIVE	SOIC	D	8	75	Green (RoHS & no Sb/Br)	CU NIPDAU	Level-1-260C-UNLIM	-40 to 125	O2365A	Samples
OPA2365AIDG4	ACTIVE	SOIC	D	8	75	Green (RoHS & no Sb/Br)	CU NIPDAU	Level-1-260C-UNLIM	-40 to 125	O2365A	Samples
OPA2365AIDR	ACTIVE	SOIC	D	8	2500	Green (RoHS & no Sb/Br)	CU NIPDAU	Level-1-260C-UNLIM	-40 to 125	O2365A	Samples
OPA2365AIDRG4	ACTIVE	SOIC	D	8	2500	Green (RoHS & no Sb/Br)	CU NIPDAU	Level-1-260C-UNLIM	-40 to 125	O2365A	Samples
OPA365AID	ACTIVE	SOIC	D	8	75	Green (RoHS & no Sb/Br)	CU NIPDAU	Level-1-260C-UNLIM	-40 to 125	O365A	Samples
OPA365AIDBVR	ACTIVE	SOT-23	DBV	5	3000	Green (RoHS & no Sb/Br)	CU NIPDAU	Level-1-260C-UNLIM	-40 to 125	OAVQ	Samples
OPA365AIDBVRG4	ACTIVE	SOT-23	DBV	5	3000	Green (RoHS & no Sb/Br)	CU NIPDAU	Level-1-260C-UNLIM	-40 to 125	OAVQ	Samples
OPA365AIDBVT	ACTIVE	SOT-23	DBV	5	250	Green (RoHS & no Sb/Br)	CU NIPDAU	Level-1-260C-UNLIM	-40 to 125	OAVQ	Samples
OPA365AIDBVTG4	ACTIVE	SOT-23	DBV	5	250	Green (RoHS & no Sb/Br)	CU NIPDAU	Level-1-260C-UNLIM	-40 to 125	OAVQ	Samples
OPA365AIDG4	ACTIVE	SOIC	D	8	75	Green (RoHS & no Sb/Br)	CU NIPDAU	Level-1-260C-UNLIM	-40 to 125	O365A	Samples
OPA365AIDR	ACTIVE	SOIC	D	8	2500	Green (RoHS & no Sb/Br)	CU NIPDAU	Level-1-260C-UNLIM	-40 to 125	O365A	Samples
OPA365AIDRG4	ACTIVE	SOIC	D	8	2500	Green (RoHS & no Sb/Br)	CU NIPDAU	Level-1-260C-UNLIM	-40 to 125	O365A	Samples

(1) The marketing status values are defined as follows:

ACTIVE: Product device recommended for new designs.

LIFEBUY: TI has announced that the device will be discontinued, and a lifetime-buy period is in effect.

NRND: Not recommended for new designs. Device is in production to support existing customers, but TI does not recommend using this part in a new design.

PREVIEW: Device has been announced but is not in production. Samples may or may not be available.

OBSELETE: TI has discontinued the production of the device.

(2) Eco Plan - The planned eco-friendly classification: Pb-Free (RoHS), Pb-Free (RoHS Exempt), or Green (RoHS & no Sb/Br) - please check <http://www.ti.com/productcontent> for the latest availability information and additional product content details.

TBD: The Pb-Free/Green conversion plan has not been defined.

Pb-Free (RoHS): TI's terms "Lead-Free" or "Pb-Free" mean semiconductor products that are compatible with the current RoHS requirements for all 6 substances, including the requirement that lead not exceed 0.1% by weight in homogeneous materials. Where designed to be soldered at high temperatures, TI Pb-Free products are suitable for use in specified lead-free processes.

Pb-Free (RoHS Exempt): This component has a RoHS exemption for either 1) lead-based flip-chip solder bumps used between the die and package, or 2) lead-based die adhesive used between the die and leadframe. The component is otherwise considered Pb-Free (RoHS compatible) as defined above.

Green (RoHS & no Sb/Br): TI defines "Green" to mean Pb-Free (RoHS compatible), and free of Bromine (Br) and Antimony (Sb) based flame retardants (Br or Sb do not exceed 0.1% by weight in homogeneous material)

⁽³⁾ MSL, Peak Temp. - The Moisture Sensitivity Level rating according to the JEDEC industry standard classifications, and peak solder temperature.

⁽⁴⁾ There may be additional marking, which relates to the logo, the lot trace code information, or the environmental category on the device.

⁽⁵⁾ Multiple Device Markings will be inside parentheses. Only one Device Marking contained in parentheses and separated by a "~" will appear on a device. If a line is indented then it is a continuation of the previous line and the two combined represent the entire Device Marking for that device.

⁽⁶⁾ Lead/Ball Finish - Orderable Devices may have multiple material finish options. Finish options are separated by a vertical ruled line. Lead/Ball Finish values may wrap to two lines if the finish value exceeds the maximum column width.

Important Information and Disclaimer: The information provided on this page represents TI's knowledge and belief as of the date that it is provided. TI bases its knowledge and belief on information provided by third parties, and makes no representation or warranty as to the accuracy of such information. Efforts are underway to better integrate information from third parties. TI has taken and continues to take reasonable steps to provide representative and accurate information but may not have conducted destructive testing or chemical analysis on incoming materials and chemicals. TI and TI suppliers consider certain information to be proprietary, and thus CAS numbers and other limited information may not be available for release.

In no event shall TI's liability arising out of such information exceed the total purchase price of the TI part(s) at issue in this document sold by TI to Customer on an annual basis.

OTHER QUALIFIED VERSIONS OF OPA2365, OPA365 :

● Automotive: [OPA2365-Q1](#), [OPA365-Q1](#)

● Enhanced Product: [OPA365-EP](#)

NOTE: Qualified Version Definitions:

- Automotive - Q100 devices qualified for high-reliability automotive applications targeting zero defects
- Enhanced Product - Supports Defense, Aerospace and Medical Applications

TAPE AND REEL INFORMATION

QUADRANT ASSIGNMENTS FOR PIN 1 ORIENTATION IN TAPE

*All dimensions are nominal

Device	Package Type	Package Drawing	Pins	SPQ	Reel Diameter (mm)	Reel Width W1 (mm)	A0 (mm)	B0 (mm)	K0 (mm)	P1 (mm)	W (mm)	Pin1 Quadrant
OPA2365AIDR	SOIC	D	8	2500	330.0	12.4	6.4	5.2	2.1	8.0	12.0	Q1
OPA365AIDBVR	SOT-23	DBV	5	3000	178.0	9.0	3.3	3.2	1.4	4.0	8.0	Q3
OPA365AIDBVT	SOT-23	DBV	5	250	178.0	9.0	3.3	3.2	1.4	4.0	8.0	Q3
OPA365AIDR	SOIC	D	8	2500	330.0	12.4	6.4	5.2	2.1	8.0	12.0	Q1

TAPE AND REEL BOX DIMENSIONS



*All dimensions are nominal

Device	Package Type	Package Drawing	Pins	SPQ	Length (mm)	Width (mm)	Height (mm)
OPA2365AIDR	SOIC	D	8	2500	367.0	367.0	35.0
OPA365AIDBVR	SOT-23	DBV	5	3000	180.0	180.0	18.0
OPA365AIDBVT	SOT-23	DBV	5	250	180.0	180.0	18.0
OPA365AIDR	SOIC	D	8	2500	367.0	367.0	35.0

EXAMPLE BOARD LAYOUT

D0008A

SOIC - 1.75 mm max height

SMALL OUTLINE INTEGRATED CIRCUIT

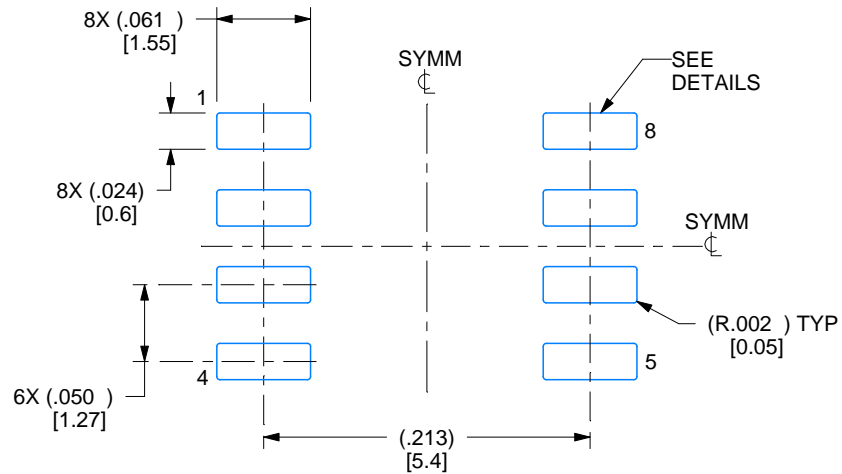

LAND PATTERN EXAMPLE
EXPOSED METAL SHOWN
SCALE:8X



SOLDER MASK DETAILS

4214825/C 02/2019

NOTES: (continued)

6. Publication IPC-7351 may have alternate designs.

7. Solder mask tolerances between and around signal pads can vary based on board fabrication site.

EXAMPLE STENCIL DESIGN

D0008A

SOIC - 1.75 mm max height

SMALL OUTLINE INTEGRATED CIRCUIT



SOLDER PASTE EXAMPLE
BASED ON .005 INCH [0.125 MM] THICK STENCIL
SCALE:8X

4214825/C 02/2019

NOTES: (continued)

8. Laser cutting apertures with trapezoidal walls and rounded corners may offer better paste release. IPC-7525 may have alternate design recommendations.
9. Board assembly site may have different recommendations for stencil design.

DBV0005A



PACKAGE OUTLINE

SOT-23 - 1.45 mm max height

SMALL OUTLINE TRANSISTOR



4214839/D 11/2018

NOTES:

1. All linear dimensions are in millimeters. Any dimensions in parenthesis are for reference only. Dimensioning and tolerancing per ASME Y14.5M.
2. This drawing is subject to change without notice.
3. Reference JEDEC MO-178.
4. Body dimensions do not include mold flash, protrusions, or gate burrs. Mold flash, protrusions, or gate burrs shall not exceed 0.15 mm per side.

EXAMPLE BOARD LAYOUT

DBV0005A

SOT-23 - 1.45 mm max height

SMALL OUTLINE TRANSISTOR



LAND PATTERN EXAMPLE
EXPOSED METAL SHOWN
SCALE:15X



SOLDER MASK DETAILS

4214839/D 11/2018

NOTES: (continued)

- 5. Publication IPC-7351 may have alternate designs.
- 6. Solder mask tolerances between and around signal pads can vary based on board fabrication site.

EXAMPLE STENCIL DESIGN

DBV0005A

SOT-23 - 1.45 mm max height

SMALL OUTLINE TRANSISTOR



SOLDER PASTE EXAMPLE
BASED ON 0.125 mm THICK STENCIL
SCALE:15X

4214839/D 11/2018

NOTES: (continued)

7. Laser cutting apertures with trapezoidal walls and rounded corners may offer better paste release. IPC-7525 may have alternate design recommendations.
8. Board assembly site may have different recommendations for stencil design.

IMPORTANT NOTICE AND DISCLAIMER

TI PROVIDES TECHNICAL AND RELIABILITY DATA (INCLUDING DATASHEETS), DESIGN RESOURCES (INCLUDING REFERENCE DESIGNS), APPLICATION OR OTHER DESIGN ADVICE, WEB TOOLS, SAFETY INFORMATION, AND OTHER RESOURCES "AS IS" AND WITH ALL FAULTS, AND DISCLAIMS ALL WARRANTIES, EXPRESS AND IMPLIED, INCLUDING WITHOUT LIMITATION ANY IMPLIED WARRANTIES OF MERCHANTABILITY, FITNESS FOR A PARTICULAR PURPOSE OR NON-INFRINGEMENT OF THIRD PARTY INTELLECTUAL PROPERTY RIGHTS.

These resources are intended for skilled developers designing with TI products. You are solely responsible for (1) selecting the appropriate TI products for your application, (2) designing, validating and testing your application, and (3) ensuring your application meets applicable standards, and any other safety, security, or other requirements. These resources are subject to change without notice. TI grants you permission to use these resources only for development of an application that uses the TI products described in the resource. Other reproduction and display of these resources is prohibited. No license is granted to any other TI intellectual property right or to any third party intellectual property right. TI disclaims responsibility for, and you will fully indemnify TI and its representatives against, any claims, damages, costs, losses, and liabilities arising out of your use of these resources.

TI's products are provided subject to TI's Terms of Sale (www.ti.com/legal/termsofsale.html) or other applicable terms available either on ti.com or provided in conjunction with such TI products. TI's provision of these resources does not expand or otherwise alter TI's applicable warranties or warranty disclaimers for TI products.

Mailing Address: Texas Instruments, Post Office Box 655303, Dallas, Texas 75265
Copyright © 2019, Texas Instruments Incorporated

Looking for pricing, stock, or lifecycle information?

Click below to explore more details on WIN SOURCE:

 [View OPA365AIDBVT on WIN SOURCE](#)

 [Texas Instruments](#) Information

Optimize Your Supply Chain with WIN SOURCE Solutions

-  Global Sourcing Solution
-  Obsolete Management
-  Cost Control Management
-  Shortage Management
-  Alternative Solution
-  Excess Inventory Management