



THE DATASHEET OF OPA690IDBVRG4



OPA690 Wideband, Voltage-Feedback Operational Amplifier With Disable

1 Features

- Flexible Supply Range:
 - 5-V to 12-V Single Supply
 - ± 2.5 -V to ± 5 -V Dual Supply
- Unity-Gain Stable: 500 MHz ($G = 1$)
- High Output Current: 190 mA
- Output Voltage Swing: ± 4 V
- High Slew Rate: 1800 V/ μ s
- Low Supply Current: 5.5 mA
- Low Disable Current: 100 μ A
- Wideband 5-V Operation: 220 MHz ($G = 2$)

2 Applications

- Video Line Drivers
- xDSL Line Drivers and Receivers
- High-Speed Imaging Channels
- ADC Buffers
- Portable Instruments
- Transimpedance Amplifiers
- Active Filters

3 Description

The OPA690 device represents a major step forward in unity-gain stable, voltage-feedback op amps. A new internal architecture provides slew rate and full-power bandwidth previously found only in wideband, current-feedback op amps. A new output stage architecture delivers high currents with a minimal headroom requirement. These combine to give exceptional single-supply operation. Using a single 5-V supply, the OPA690 can deliver a 1-V to 4-V output swing with over 150 mA drive current and 150 MHz bandwidth. This combination of features makes the OPA690 an ideal RGB line driver or single-supply Analog-to-Digital Converter (ADC) input driver.

The low 5.5-mA supply current of the OPA690 is precisely trimmed at 25°C. This trim, along with low temperature drift, gives lower maximum supply current than competing products. System power may be reduced further using the optional disable control pin. Leaving this disable pin open, or holding it HIGH, operates the OPA690 normally. If pulled LOW, the OPA690 supply current drops to less than 100 μ A while the output goes to a high-impedance state. This feature may be used for power savings.

Device Information⁽¹⁾

PART NUMBER	PACKAGE	BODY SIZE (NOM)
OPA690	SOIC (8)	4.90 mm \times 3.90 mm
	SOT-23 (6)	2.90 mm \times 1.60 mm

(1) For all available packages, see the orderable addendum at the end of the data sheet.

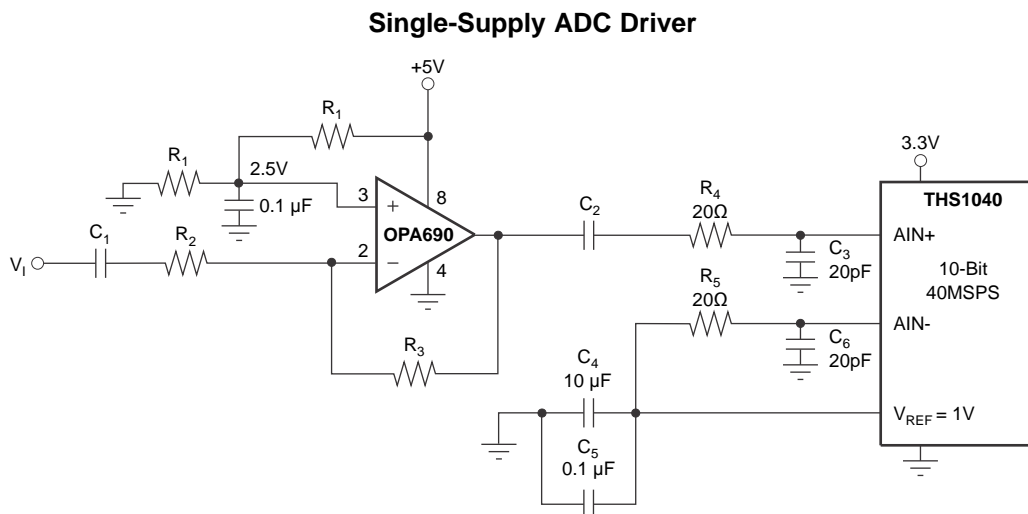

Copyright © 2016, Texas Instruments Incorporated



Table of Contents

1 Features	1	8.3 Feature Description	17
2 Applications	1	8.4 Device Functional Modes	24
3 Description	1	9 Application and Implementation	26
4 Revision History	2	9.1 Application Information	26
5 Device Comparison Table	3	9.2 Typical Applications	27
6 Pin Configuration and Functions	3	10 Power Supply Recommendations	31
7 Specifications	4	11 Layout	31
7.1 Absolute Maximum Ratings	4	11.1 Layout Guidelines	31
7.2 ESD Ratings	4	11.2 Layout Example	33
7.3 Recommended Operating Conditions	4	12 Device and Documentation Support	34
7.4 Thermal Information	4	12.1 Device Support	34
7.5 Electrical Characteristics: $V_S = \pm 5\text{ V}$	5	12.2 Receiving Notification of Documentation Updates	34
7.6 Electrical Characteristics: $V_S = 5\text{ V}$	8	12.3 Community Resources	34
7.7 Typical Characteristics	11	12.4 Trademarks	34
8 Detailed Description	17	12.5 Electrostatic Discharge Caution	34
8.1 Overview	17	12.6 Glossary	34
8.2 Functional Block Diagram	17	13 Mechanical, Packaging, and Orderable Information	35

4 Revision History

NOTE: Page numbers for previous revisions may differ from page numbers in the current version.

Changes from Revision F (February 2010) to Revision G	Page
• Added <i>ESD Ratings</i> table, <i>Feature Description</i> section, <i>Device Functional Modes</i> , <i>Application and Implementation</i> section, <i>Power Supply Recommendations</i> section, <i>Layout</i> section, <i>Device and Documentation Support</i> section, and <i>Mechanical, Packaging, and Orderable Information</i> section	1
• Deleted <i>Ordering Information</i> table, see POA at the end of the data sheet	3
• Added <i>Thermal Information</i> table	4

Changes from Revision E (November 2008) to Revision F	Page
• Changed data sheet format to current standards	1
• Deleted <i>Lead Temperature</i> specification from Absolute Maximum Ratings table	4
• Added Figure 25 , Noninverting Overdrive Recovery plot	14

Changes from Revision D (August 2008) to Revision E	Page
• Deleted obsolete OPA680 from Related Products table	3

5 Device Comparison Table

	SINGLES	DUALS	TRIPLES
Voltage-feedback	—	OPA2690	OPA3690
Current-feedback	OPA691	OPA2691	OPA3691
Fixed gain	OPA692	—	OPA3692

6 Pin Configuration and Functions

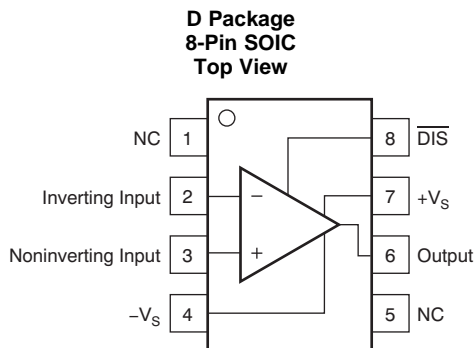

NOTE: NC = not connected.

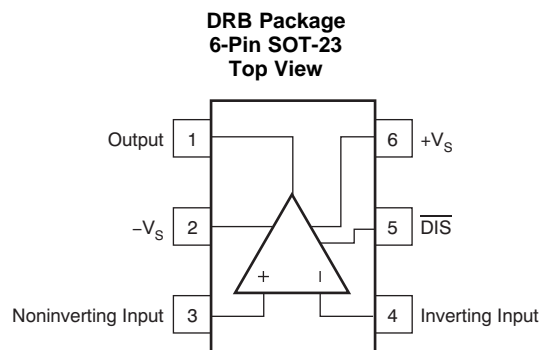

Pin Orientation/Package Marking

Pin Functions

NAME	PIN		TYPE ⁽¹⁾	DESCRIPTION
	SOIC	SOT-23		
DIS	8	5	I	Disable the op amp (low = disable, high = enable)
IN-	2	4	I	Inverting input
IN+	3	3	I	Noninverting input
NC	1, 5	—	—	No connection
Output	6	1	O	Output of amplifier
-Vs	4	2	P	Negative power supply
+Vs	7	6	P	Positive power supply

(1) I = Input, O = Output, P = Power

7 Specifications

7.1 Absolute Maximum Ratings

over operating free-air temperature range (unless otherwise noted)⁽¹⁾

	MIN	MAX	UNIT
Power supply		±6.5	V _{DC}
Internal power dissipation	See Thermal Analysis		
Differential input voltage		±1.2	V
Input voltage		±V _S	V
Junction temperature, T _J		175	°C
Storage temperature, T _{stg}	–65	125	°C

- (1) Stresses beyond those listed under *Absolute Maximum Ratings* may cause permanent damage to the device. These are stress ratings only, which do not imply functional operation of the device at these or any other conditions beyond those indicated under *Recommended Operating Conditions*. Exposure to absolute-maximum-rated conditions for extended periods may affect device reliability.

7.2 ESD Ratings

		VALUE	UNIT
V _(ESD) Electrostatic discharge	Human-body model (HBM), per ANSI/ESDA/JEDEC JS-001 ⁽¹⁾	±2000	V
	Charged-device model (CDM), per JEDEC specification JESD22-C101 ⁽²⁾	±1500	
	Machine-model (MM)	±200	

- (1) JEDEC document JEP155 states that 500-V HBM allows safe manufacturing with a standard ESD control process.
 (2) JEDEC document JEP157 states that 250-V CDM allows safe manufacturing with a standard ESD control process.

7.3 Recommended Operating Conditions

over operating free-air temperature range (unless otherwise noted)

		MIN	NOM	MAX	UNIT
V _S	Total supply voltage	±2.5	±5	±6	V
T _A	Operating temperature	–40		85	°C

7.4 Thermal Information

THERMAL METRIC ⁽¹⁾	OPA690		UNIT	
	D (SOIC)	DRB (SOT-23)		
	8 PINS	6 PINS		
R _{θJA}	Junction-to-ambient thermal resistance	125	150	°C/W
R _{θJC(top)}	Junction-to-case (top) thermal resistance	70	131.8	°C/W
R _{θJB}	Junction-to-board thermal resistance	65.3	34.9	°C/W
ψ _{JT}	Junction-to-top characterization parameter	25.6	25.6	°C/W
ψ _{JB}	Junction-to-board characterization parameter	64.8	34.2	°C/W
R _{θJC(bot)}	Junction-to-case (bottom) thermal resistance	—	—	°C/W

- (1) For more information about traditional and new thermal metrics, see the [Semiconductor and IC Package Thermal Metrics](#) application report.

7.5 Electrical Characteristics: $V_S = \pm 5\text{ V}$

at $R_F = 402\ \Omega$, $R_L = 100\ \Omega$, $G = 2$, see [Figure 36](#) for ac performance only (unless otherwise noted)

PARAMETER	TEST CONDITIONS	MIN	TYP	MAX	UNIT	
AC PERFORMANCE (SEE Figure 36)						
Small-signal bandwidth	$G = 1$, $V_O = 0.5\text{ V}_{PP}$, $R_F = 25\ \Omega$		500 ⁽¹⁾		MHz	
	$G = 2$, $V_O = 0.5\text{ V}_{PP}$	$T_A = 25^\circ\text{C}$ ⁽²⁾	165	220		
		$T_A = 0^\circ\text{C to } 70^\circ\text{C}$ ⁽³⁾	160			
		$T_A = -40^\circ\text{C to } 85^\circ\text{C}$ ⁽³⁾	150			
	$G = 10$, $V_O = 0.5\text{ V}_{PP}$	$T_A = 25^\circ\text{C}$ ⁽²⁾	20	30		
		$T_A = 0^\circ\text{C to } 70^\circ\text{C}$ ⁽³⁾	19			
$T_A = -40^\circ\text{C to } 85^\circ\text{C}$ ⁽³⁾		18				
Gain bandwidth product	$G \geq 10$	$T_A = 25^\circ\text{C}$ ⁽²⁾	200	300	MHz	
		$T_A = 0^\circ\text{C to } 70^\circ\text{C}$ ⁽³⁾	190			
		$T_A = -40^\circ\text{C to } 85^\circ\text{C}$ ⁽³⁾	180			
Bandwidth for 0.1-dB gain flatness	$G = 2$, $V_O < 0.5\text{ V}_{PP}$		30 ⁽¹⁾		MHz	
Peaking at a gain of 1	$V_O < 0.5\text{ V}_{PP}$		4 ⁽¹⁾		dB	
Large-signal bandwidth	$G = 2$, $V_O < 0.5\text{ V}_{PP}$		200 ⁽¹⁾		MHz	
Slew rate	$G = 2$, 4-V step	$T_A = 25^\circ\text{C}$ ⁽²⁾	1400	1800	V/ μs	
		$T_A = 0^\circ\text{C to } 70^\circ\text{C}$ ⁽³⁾	1200			
		$T_A = -40^\circ\text{C to } 85^\circ\text{C}$ ⁽³⁾	900			
Rise-and-fall time	$G = 2$, $V_O = 0.5\text{-V step}$		1.4 ⁽¹⁾		ns	
	$G = 2$, $V_O = 5\text{-V step}$		2.8 ⁽¹⁾			
Settling time	0.02%, $G = 2$, $V_O = 2\text{-V step}$		12 ⁽¹⁾		ns	
	0.1%, $G = 2$, $V_O = 2\text{-V step}$		8 ⁽¹⁾			
Harmonic distortion	2nd-harmonic, $G = 2$, $f = 5\text{ MHz}$, $V_O = 2\text{ V}_{PP}$, $R_L = 100\ \Omega$	$T_A = 25^\circ\text{C}$ ⁽²⁾		-68	-64	dBc
		$T_A = 0^\circ\text{C to } 70^\circ\text{C}$ ⁽³⁾			-62	
		$T_A = -40^\circ\text{C to } 85^\circ\text{C}$ ⁽³⁾			-60	
	2nd-harmonic, $G = 2$, $f = 5\text{ MHz}$, $V_O = 2\text{ V}_{PP}$, $R_L \geq 500\ \Omega$	$T_A = 25^\circ\text{C}$ ⁽²⁾		-77	-70	dBc
		$T_A = 0^\circ\text{C to } 70^\circ\text{C}$ ⁽³⁾			-68	
		$T_A = -40^\circ\text{C to } 85^\circ\text{C}$ ⁽³⁾			-66	
	3rd-harmonic, $G = 2$, $f = 5\text{ MHz}$, $V_O = 2\text{ V}_{PP}$, $R_L = 100\ \Omega$	$T_A = 25^\circ\text{C}$ ⁽²⁾		-70	-68	dBc
		$T_A = 0^\circ\text{C to } 70^\circ\text{C}$ ⁽³⁾			-66	
		$T_A = -40^\circ\text{C to } 85^\circ\text{C}$ ⁽³⁾			-64	
	3rd-harmonic, $G = 2$, $f = 5\text{ MHz}$, $V_O = 2\text{ V}_{PP}$, $R_L \geq 500\ \Omega$	$T_A = 25^\circ\text{C}$ ⁽²⁾		-81	-78	dBc
		$T_A = 0^\circ\text{C to } 70^\circ\text{C}$ ⁽³⁾			-76	
		$T_A = -40^\circ\text{C to } 85^\circ\text{C}$ ⁽³⁾			-75	
Input voltage noise	$f > 1\text{ MHz}$		5.5 ⁽¹⁾		nV/ $\sqrt{\text{Hz}}$	
Input current noise	$f > 1\text{ MHz}$		3.1 ⁽¹⁾		pA/ $\sqrt{\text{Hz}}$	
Differential gain	$G = 2$, NTSC, $V_O = 1.4\text{ V}_P$, $R_L = 150\ \Omega$		0.06% ⁽¹⁾			
Differential phase	$G = 2$, NTSC, $V_O = 1.4\text{ V}_P$, $R_L = 150\ \Omega$		0.03 ⁽¹⁾		°	

(1) Typical value only for information.

(2) Junction temperature = ambient for 25°C specifications

(3) Junction temperature = ambient at low temperature limits; junction temperature = ambient 10°C at high temperature limit for over temperature specifications

Electrical Characteristics: $V_S = \pm 5\text{ V}$ (continued)

at $R_F = 402\ \Omega$, $R_L = 100\ \Omega$, $G = 2$, see [Figure 36](#) for ac performance only (unless otherwise noted)

PARAMETER		TEST CONDITIONS		MIN	TYP	MAX	UNIT	
DC PERFORMANCE⁽⁴⁾								
A_{OL}	Open-loop voltage gain	$V_O = 0\text{ V}$, $R_L = 100\ \Omega$	$T_A = 25^\circ\text{C}^{(2)}$	58	69		dB	
			$T_A = 0^\circ\text{C to } 70^\circ\text{C}^{(3)}$	56				
			$T_A = -40^\circ\text{C to } 85^\circ\text{C}^{(3)}$	54				
Input offset voltage	$V_{CM} = 0\text{ V}$		$T_A = 25^\circ\text{C}^{(2)}$		± 1	± 4	mV	
			$T_A = 0^\circ\text{C to } 70^\circ\text{C}^{(3)}$			± 4.5		
			$T_A = -40^\circ\text{C to } 85^\circ\text{C}^{(3)}$			± 4.7		
Average offset voltage drift	$V_{CM} = 0\text{ V}$		$T_A = 0^\circ\text{C to } 70^\circ\text{C}^{(3)}$			± 10	$\mu\text{V}/^\circ\text{C}$	
			$T_A = -40^\circ\text{C to } 85^\circ\text{C}^{(3)}$			± 10		
Input bias current	$V_{CM} = 0\text{ V}$		$T_A = 25^\circ\text{C}^{(2)}$		± 3	± 10	μA	
			$T_A = 0^\circ\text{C to } 70^\circ\text{C}^{(3)}$			± 11		
			$T_A = -40^\circ\text{C to } 85^\circ\text{C}^{(3)}$			± 12		
Average bias current drift (magnitude)	$V_{CM} = 0\text{ V}$		$T_A = 0^\circ\text{C to } 70^\circ\text{C}^{(3)}$			± 20	$\text{nA}/^\circ\text{C}$	
			$T_A = -40^\circ\text{C to } 85^\circ\text{C}^{(3)}$			± 40		
Input offset current	$V_{CM} = 0\text{ V}$		$T_A = 25^\circ\text{C}^{(2)}$		± 0.1	± 1	μA	
			$T_A = 0^\circ\text{C to } 70^\circ\text{C}^{(3)}$			± 1.4		
			$T_A = -40^\circ\text{C to } 85^\circ\text{C}^{(3)}$			± 1.6		
Average offset current drift	$V_{CM} = 0\text{ V}$		$T_A = 0^\circ\text{C to } 70^\circ\text{C}^{(3)}$			± 7	$\text{nA}/^\circ\text{C}$	
			$T_A = -40^\circ\text{C to } 85^\circ\text{C}^{(3)}$			± 9		
INPUT								
CMIR	Common-mode input voltage ⁽⁵⁾		$T_A = 25^\circ\text{C}^{(2)}$	± 3.4	± 3.5		V	
			$T_A = 0^\circ\text{C to } 70^\circ\text{C}^{(3)}$	± 3.3				
			$T_A = -40^\circ\text{C to } 85^\circ\text{C}^{(3)}$	± 3.2				
CMRR	Common-mode rejection ratio	$V_{CM} = \pm 1\text{ V}$	$T_A = 25^\circ\text{C}^{(2)}$	60	65		dB	
			$T_A = 0^\circ\text{C to } 70^\circ\text{C}^{(3)}$	57				
			$T_A = -40^\circ\text{C to } 85^\circ\text{C}^{(3)}$	56				
Input impedance		Differential mode, $V_{CM} = 0\text{ V}$			$190\ \Omega \parallel 0.6^{(1)}$		$\text{k}\Omega \parallel \text{pF}$	
		Common-mode, $V_{CM} = 0\text{ V}$			$3.2\ \Omega \parallel 0.9^{(1)}$		$\text{M}\Omega \parallel \text{pF}$	
OUTPUT								
Voltage output swing	No load		$T_A = 25^\circ\text{C}^{(2)}$	± 3.8	± 4		V	
			$T_A = 0^\circ\text{C to } 70^\circ\text{C}^{(3)}$	± 3.7				
			$T_A = -40^\circ\text{C to } 85^\circ\text{C}^{(3)}$	± 3.6				
	$R_L = 100\ \Omega$			$T_A = 25^\circ\text{C}^{(2)}$	± 3.7	± 3.9		V
				$T_A = 0^\circ\text{C to } 70^\circ\text{C}^{(3)}$	± 3.6			
				$T_A = -40^\circ\text{C to } 85^\circ\text{C}^{(3)}$	± 3.3			
Current output	Sourcing, $V_O = 0\text{ V}$		$T_A = 25^\circ\text{C}^{(2)}$	160	190		mA	
			$T_A = 0^\circ\text{C to } 70^\circ\text{C}^{(3)}$	140				
			$T_A = -40^\circ\text{C to } 85^\circ\text{C}^{(3)}$	100				
	Sinking, $V_O = 0\text{ V}$			$T_A = 25^\circ\text{C}^{(2)}$	-160	-190		mA
				$T_A = 0^\circ\text{C to } 70^\circ\text{C}^{(3)}$	-140			
				$T_A = -40^\circ\text{C to } 85^\circ\text{C}^{(3)}$	-100			
Short-circuit current limit	$V_O = 0\text{ V}$				$\pm 250^{(1)}$		mA	
Closed-loop output impedance	$G = 2$, $f = 100\text{ kHz}$				$0.04^{(1)}$		Ω	

(4) Current is considered positive out of node.

(5) Tested < 3 dB below minimum specified CMRR at $\pm\text{CMIR}$ limits.

Electrical Characteristics: $V_S = \pm 5\text{ V}$ (continued)

at $R_F = 402\ \Omega$, $R_L = 100\ \Omega$, $G = 2$, see [Figure 36](#) for ac performance only (unless otherwise noted)

PARAMETER		TEST CONDITIONS		MIN	TYP	MAX	UNIT	
DISABLE (DISABLED LOW)								
+ V_S	Power-down supply current	$V_{DIS} = 0\text{ V}$	$T_A = 25^\circ\text{C}^{(2)}$		-100	-200	μA	
			$T_A = 0^\circ\text{C to } 70^\circ\text{C}^{(3)}$			-240		
			$T_A = -40^\circ\text{C to } 85^\circ\text{C}^{(3)}$			-260		
	Disable time	$V_{IN} = 1\text{ V}_{DC}$			200 ⁽¹⁾		ns	
	Enable time	$V_{IN} = 1\text{ V}_{DC}$			25 ⁽¹⁾		ns	
	Off isolation	$G = 2$, $R_L = 150\ \Omega$, $V_{IN} = 0\text{ V}$			70 ⁽¹⁾		dB	
	Output capacitance in disable	$G = 2$, $R_L = 150\ \Omega$, $V_{IN} = 0\text{ V}$			4 ⁽¹⁾		pF	
	Turnon glitch				$\pm 50^{(1)}$		mV	
	Turnoff glitch				$\pm 20^{(1)}$		mV	
	Enable voltage	$T_A = 25^\circ\text{C}^{(2)}$ $T_A = 0^\circ\text{C to } 70^\circ\text{C}^{(3)}$ $T_A = -40^\circ\text{C to } 85^\circ\text{C}^{(3)}$		3.5	3.3		V	
			3.6					
			3.7					
	Disable voltage	$T_A = 25^\circ\text{C}^{(2)}$ $T_A = 0^\circ\text{C to } 70^\circ\text{C}^{(3)}$ $T_A = -40^\circ\text{C to } 85^\circ\text{C}^{(3)}$			1.8	1.7	V	
						1.6		
						1.5		
V_{DIS}	Control pin input bias current	$V_{DIS} = 0\text{ V}$	$T_A = 25^\circ\text{C}^{(2)}$		75	130	μA	
			$T_A = 0^\circ\text{C to } 70^\circ\text{C}^{(3)}$					150
			$T_A = -40^\circ\text{C to } 85^\circ\text{C}^{(3)}$					160
POWER SUPPLY								
	Specified operating voltage				$\pm 5^{(1)}$		V	
	Maximum operating voltage	$T_A = 25^\circ\text{C}^{(2)}$, $T_A = 0^\circ\text{C to } 70^\circ\text{C}^{(3)}$, and $T_A = -40^\circ\text{C to } 85^\circ\text{C}^{(3)}$				± 6	V	
	Maximum quiescent current	$V_S = \pm 5\text{ V}$	$T_A = 25^\circ\text{C}^{(2)}$		5.5	5.8	mA	
$T_A = 0^\circ\text{C to } 70^\circ\text{C}^{(3)}$						6.2		
$T_A = -40^\circ\text{C to } 85^\circ\text{C}^{(3)}$						6.6		
	Minimum quiescent current	$V_S = \pm 5\text{ V}$	$T_A = 25^\circ\text{C}^{(2)}$		5.3	5.5	mA	
$T_A = 0^\circ\text{C to } 70^\circ\text{C}^{(3)}$						4.6		
$T_A = -40^\circ\text{C to } 85^\circ\text{C}^{(3)}$						4.3		
+PSRR	Power-supply rejection ratio	Input-referred	$T_A = 25^\circ\text{C}^{(2)}$		68	75	dB	
			$T_A = 0^\circ\text{C to } 70^\circ\text{C}^{(3)}$					66
			$T_A = -40^\circ\text{C to } 85^\circ\text{C}^{(3)}$					64

7.6 Electrical Characteristics: $V_S = 5\text{ V}$

$R_F = 402\ \Omega$, $R_L = 100\ \Omega$, and $G = 2$; see [Figure 37](#) for ac performance only (unless otherwise noted)

PARAMETER	TEST CONDITIONS	MIN	TYP	MAX	UNIT	
AC PERFORMANCE (SEE Figure 37)						
Small-signal bandwidth	$G = 1$, $V_O = 0.5\ V_{PP}$, $R_F = \pm 25\ \Omega$			400 ⁽¹⁾	MHz	
		$G = 2$, $V_O < 0.5\ V_{PP}$	$T_A = 25^\circ\text{C}$ ⁽²⁾	150		190
			$T_A = 0^\circ\text{C to } 70^\circ\text{C}$ ⁽³⁾	145		
		$T_A = -40^\circ\text{C to } 85^\circ\text{C}$ ⁽³⁾	140			
	$G = 10$, $V_O < 0.5\ V_{PP}$	$T_A = 25^\circ\text{C}$ ⁽²⁾	18	25		
		$T_A = 0^\circ\text{C to } 70^\circ\text{C}$ ⁽³⁾	17			
$T_A = -40^\circ\text{C to } 85^\circ\text{C}$ ⁽³⁾		16				
Gain bandwidth product	$G \geq 10$	$T_A = 25^\circ\text{C}$ ⁽²⁾	180	250	MHz	
		$T_A = 0^\circ\text{C to } 70^\circ\text{C}$ ⁽³⁾	170			
		$T_A = -40^\circ\text{C to } 85^\circ\text{C}$ ⁽³⁾	160			
Bandwidth for 0.1-dB gain flatness	$G = 2$, $V_O < 0.5\ V_{PP}$			20 ⁽¹⁾	MHz	
Peaking at a gain of +1	$V_O < 0.5\ V_{PP}$			5 ⁽¹⁾	dB	
Large-signal bandwidth	$G = 2$, $V_O = 2\ V_{PP}$			220 ⁽¹⁾	MHz	
Slew rate	$G = 2$, 2-V step	$T_A = 25^\circ\text{C}$ ⁽²⁾	700	1000	V/ μ s	
		$T_A = 0^\circ\text{C to } 70^\circ\text{C}$ ⁽³⁾	670			
		$T_A = -40^\circ\text{C to } 85^\circ\text{C}$ ⁽³⁾	550			
Rise-and-fall time	$G = 2$, $V_O = 0.5\text{-V step}$			1.6 ⁽¹⁾	ns	
	$G = 2$, $V_O = 2\text{-V step}$			2 ⁽¹⁾		
Settling time	0.02%, $G = 2$, $V_O = 2\text{-V step}$			12 ⁽¹⁾	ns	
	0.1%, $G = 2$, $V_O = 2\text{-V step}$			8 ⁽¹⁾		
Harmonic distortion	2nd-harmonic, $G = 2$, $f = 5\ \text{MHz}$, $V_O = 2\ V_{PP}$, $R_L = 100\ \Omega\ \text{to}\ V_S/2$	$T_A = 25^\circ\text{C}$ ⁽²⁾	-65	-60	dBc	
		$T_A = 0^\circ\text{C to } 70^\circ\text{C}$ ⁽³⁾		-59		
		$T_A = -40^\circ\text{C to } 85^\circ\text{C}$ ⁽³⁾		-56		
	2nd-harmonic, $G = 2$, $f = 5\ \text{MHz}$, $V_O = 2\ V_{PP}$, $R_L \geq 500\ \Omega\ \text{to}\ V_S/2$	$T_A = 25^\circ\text{C}$ ⁽²⁾	-75	-70		
		$T_A = 0^\circ\text{C to } 70^\circ\text{C}$ ⁽³⁾		-68		
		$T_A = -40^\circ\text{C to } 85^\circ\text{C}$ ⁽³⁾		-66		
	3rd-harmonic, $G = 2$, $f = 5\ \text{MHz}$, $V_O = 2\ V_{PP}$, $R_L = 100\ \Omega\ \text{to}\ V_S/2$	$T_A = 25^\circ\text{C}$ ⁽²⁾	-68	-64		
		$T_A = 0^\circ\text{C to } 70^\circ\text{C}$ ⁽³⁾		-62		
		$T_A = -40^\circ\text{C to } 85^\circ\text{C}$ ⁽³⁾		-60		
	3rd-harmonic, $G = 2$, $f = 5\ \text{MHz}$, $V_O = 2\ V_{PP}$, $R_L \geq 500\ \Omega\ \text{to}\ V_S/2$	$T_A = 25^\circ\text{C}$ ⁽²⁾	-77	-73		
		$T_A = 0^\circ\text{C to } 70^\circ\text{C}$ ⁽³⁾		-71		
		$T_A = -40^\circ\text{C to } 85^\circ\text{C}$ ⁽³⁾		-70		
Input voltage noise	$f > 1\ \text{MHz}$			5.6 ⁽¹⁾	nV/ $\sqrt{\text{Hz}}$	
Input current noise	$f > 1\ \text{MHz}$			3.2 ⁽¹⁾	pA/ $\sqrt{\text{Hz}}$	
Differential gain	$G = 2$, NTSC, $V_O = 1.4\ V_P$, $R_L = 150\ \Omega\ \text{to}\ V_S/2$			0.06% ⁽¹⁾		
Differential phase	$G = 2$, NTSC, $V_O = 1.4\ V_P$, $R_L = 150\ \Omega\ \text{to}\ V_S/2$			0.02 ⁽¹⁾	°	

(1) Typical value only for information.

(2) Junction temperature = ambient for 25°C specifications.

(3) Junction temperature = ambient at low temperature limits; junction temperature = ambient 10°C at high temperature limit for over temperature specifications.

Electrical Characteristics: $V_S = 5\text{ V}$ (continued)
 $R_F = 402\ \Omega$, $R_L = 100\ \Omega$, and $G = 2$; see [Figure 37](#) for ac performance only (unless otherwise noted)

PARAMETER		TEST CONDITIONS		MIN	TYP	MAX	UNIT
DC PERFORMANCE⁽⁴⁾							
A_{OL}	Open-loop voltage gain	$V_O = 2.5\text{ V}$, $R_L = 100\ \Omega$ to $V_S/2$	$T_A = 25^\circ\text{C}^{(2)}$	56	63		dB
			$T_A = 0^\circ\text{C to } 70^\circ\text{C}^{(3)}$	54			
			$T_A = -40^\circ\text{C to } 85^\circ\text{C}^{(3)}$	52			
Input offset voltage	$V_{CM} = 2.5\text{ V}$		$T_A = 25^\circ\text{C}^{(2)}$		± 1	± 4	mV
			$T_A = 0^\circ\text{C to } 70^\circ\text{C}^{(3)}$			± 4.3	
			$T_A = -40^\circ\text{C to } 85^\circ\text{C}^{(3)}$			± 4.7	
Average offset voltage drift		$V_{CM} = 2.5\text{ V}$, $T_A = 0^\circ\text{C to } 70^\circ\text{C}^{(3)}$ and $T_A = -40^\circ\text{C to } 85^\circ\text{C}^{(3)}$				± 10	$\mu\text{V}/^\circ\text{C}$
Input bias current	$V_{CM} = 2.5\text{ V}$		$T_A = 25^\circ\text{C}^{(2)}$		± 3	± 10	μA
			$T_A = 0^\circ\text{C to } 70^\circ\text{C}^{(3)}$			± 11	
			$T_A = -40^\circ\text{C to } 85^\circ\text{C}^{(3)}$			± 12	
Average bias current drift (magnitude)	$V_{CM} = 2.5\text{ V}$		$T_A = 0^\circ\text{C to } 70^\circ\text{C}^{(3)}$			± 20	$\text{nA}/^\circ\text{C}$
			$T_A = -40^\circ\text{C to } 85^\circ\text{C}^{(3)}$			± 40	
Input offset current	$V_{CM} = 2.5\text{ V}$		$T_A = 25^\circ\text{C}^{(2)}$		± 0.3	± 1	μA
			$T_A = 0^\circ\text{C to } 70^\circ\text{C}^{(3)}$			± 1.4	
			$T_A = -40^\circ\text{C to } 85^\circ\text{C}^{(3)}$			± 1.6	
Average offset current drift	$V_{CM} = 2.5\text{ V}$		$T_A = 0^\circ\text{C to } 70^\circ\text{C}^{(3)}$			± 7	$\text{nA}/^\circ\text{C}$
			$T_A = -40^\circ\text{C to } 85^\circ\text{C}^{(3)}$			± 9	
INPUT							
Least positive input voltage ⁽⁵⁾			$T_A = 25^\circ\text{C}^{(2)}$	1.6	1.5		V
			$T_A = 0^\circ\text{C to } 70^\circ\text{C}^{(3)}$	1.7			
			$T_A = -40^\circ\text{C to } 85^\circ\text{C}^{(3)}$	1.8			
Most positive input voltage ⁽⁵⁾			$T_A = 25^\circ\text{C}^{(2)}$	3.4	3.5		V
			$T_A = 0^\circ\text{C to } 70^\circ\text{C}^{(3)}$	3.3			
			$T_A = -40^\circ\text{C to } 85^\circ\text{C}^{(3)}$	3.2			
CMRR	Common-mode rejection ratio	$V_{CM} = 2.5\text{ V} \pm 0.5\text{ V}$	$T_A = 25^\circ\text{C}^{(2)}$	58	63		dB
			$T_A = 0^\circ\text{C to } 70^\circ\text{C}^{(3)}$	56			
			$T_A = -40^\circ\text{C to } 85^\circ\text{C}^{(3)}$	54			
Input impedance			Differential mode, $V_{CM} = 2.5\text{ V}$	92 1.4 ⁽¹⁾			$\text{k}\Omega$ pF
			Common-mode, $V_{CM} = 2.5\text{ V}$	2.2 1.5 ⁽¹⁾			$\text{M}\Omega$ pF
OUTPUT							
Most positive output voltage	No load		$T_A = 25^\circ\text{C}^{(2)}$	3.8	4		V
			$T_A = 0^\circ\text{C to } 70^\circ\text{C}^{(3)}$	3.6			
			$T_A = -40^\circ\text{C to } 85^\circ\text{C}^{(3)}$	3.5			
	$R_L = 100\ \Omega$ to 2.5 V		$T_A = 25^\circ\text{C}^{(2)}$	3.7	3.9		
			$T_A = 0^\circ\text{C to } 70^\circ\text{C}^{(3)}$	3.5			
			$T_A = -40^\circ\text{C to } 85^\circ\text{C}^{(3)}$	3.4			
Least positive output voltage	No load		$T_A = 25^\circ\text{C}^{(2)}$	1.2	1		V
			$T_A = 0^\circ\text{C to } 70^\circ\text{C}^{(3)}$	1.4			
			$T_A = -40^\circ\text{C to } 85^\circ\text{C}^{(3)}$	1.5			
	$R_L = 100\ \Omega$ to 2.5 V		$T_A = 25^\circ\text{C}^{(2)}$		1.1	1.3	
			$T_A = 0^\circ\text{C to } 70^\circ\text{C}^{(3)}$			1.5	
			$T_A = -40^\circ\text{C to } 85^\circ\text{C}^{(3)}$			1.7	

(4) Current is considered positive out of node.

(5) Tested < 3 dB below minimum specified CMRR at $\pm\text{CMIR}$ limits.

Electrical Characteristics: $V_S = 5\text{ V}$ (continued)
 $R_F = 402\ \Omega$, $R_L = 100\ \Omega$, and $G = 2$; see [Figure 37](#) for ac performance only (unless otherwise noted)

PARAMETER		TEST CONDITIONS		MIN	TYP	MAX	UNIT
Current output	Sourcing	$T_A = 25^\circ\text{C}^{(2)}$			160	120	mA
		$T_A = 0^\circ\text{C to } 70^\circ\text{C}^{(3)}$				100	
		$T_A = -40^\circ\text{C to } 85^\circ\text{C}^{(3)}$				80	
	Sinking	$T_A = 25^\circ\text{C}^{(2)}$		-120	-160		
		$T_A = 0^\circ\text{C to } 70^\circ\text{C}^{(3)}$		-100			
		$T_A = -40^\circ\text{C to } 85^\circ\text{C}^{(3)}$		-80			
Short-circuit current				$\pm 250^{(1)}$		mA	
Closed-loop output impedance		$G = 2$, $f = 100\text{ kHz}$		$0.04^{(1)}$		Ω	
DISABLE (DISABLED LOW)							
$+V_S$	Power-down supply current	$V_{\overline{\text{DIS}}} = 0\text{ V}$	$T_A = 25^\circ\text{C}^{(2)}$		-100	-200	μA
			$T_A = 0^\circ\text{C to } 70^\circ\text{C}^{(3)}$			-240	
			$T_A = -40^\circ\text{C to } 85^\circ\text{C}^{(3)}$			-260	
Off isolation		$G = 2$, 5 MHz		$65^{(1)}$		dB	
Output capacitance in disable				$4^{(1)}$		pF	
Turnon glitch		$G = 2$, $R_L = 150\ \Omega$, $V_{\text{IN}} = V_S/2$		$\pm 50^{(1)}$		mV	
Turnoff glitch		$G = 2$, $R_L = 150\ \Omega$, $V_{\text{IN}} = V_S/2$		$\pm 20^{(1)}$		mV	
Enable voltage	$T_A = 25^\circ\text{C}^{(2)}$		3.5	3.3		V	
	$T_A = 0^\circ\text{C to } 70^\circ\text{C}^{(3)}$		3.6				
	$T_A = -40^\circ\text{C to } 85^\circ\text{C}^{(3)}$		3.7				
Disable voltage	$T_A = 25^\circ\text{C}^{(2)}$			1.8	1.7	V	
	$T_A = 0^\circ\text{C to } 70^\circ\text{C}^{(3)}$				1.6		
	$T_A = -40^\circ\text{C to } 85^\circ\text{C}^{(3)}$				1.5		
$V_{\overline{\text{DIS}}}$	Control pin input bias current	$V_{\overline{\text{DIS}}} = 0\text{ V}$	$T_A = 25^\circ\text{C}^{(2)}$		75	130	μA
			$T_A = 0^\circ\text{C to } 70^\circ\text{C}^{(3)}$			150	
			$T_A = -40^\circ\text{C to } 85^\circ\text{C}^{(3)}$			160	
POWER SUPPLY							
Specified single-supply operating voltage				$5^{(1)}$		V	
Maximum single-supply operating voltage		$T_A = 25^\circ\text{C}^{(2)}$, $T_A = 0^\circ\text{C to } 70^\circ\text{C}^{(3)}$, and $T_A = -40^\circ\text{C to } 85^\circ\text{C}^{(3)}$				12	V
Maximum quiescent current	$V_S = \pm 5\text{ V}$	$T_A = 25^\circ\text{C}^{(2)}$		4.9	5.44	mA	
		$T_A = 0^\circ\text{C to } 70^\circ\text{C}^{(3)}$			5.72		
		$T_A = -40^\circ\text{C to } 85^\circ\text{C}^{(3)}$			6.02		
Minimum quiescent current	$V_S = \pm 5\text{ V}$	$T_A = 25^\circ\text{C}^{(2)}$		4.48	4.9	mA	
		$T_A = 0^\circ\text{C to } 70^\circ\text{C}^{(3)}$		4			
		$T_A = -40^\circ\text{C to } 85^\circ\text{C}^{(3)}$		3.86			
$+PSRR$	Power-supply rejection ratio	Input-referred		$72^{(1)}$		dB	

7.7 Typical Characteristics

7.7.1 Typical Characteristics: $V_S = \pm 5\text{ V}$

$T_A = 25^\circ\text{C}$, $G = 2$, $R_F = 402\ \Omega$, and $R_L = 100\ \Omega$; see Figure 36 for AC performance only (unless otherwise noted)

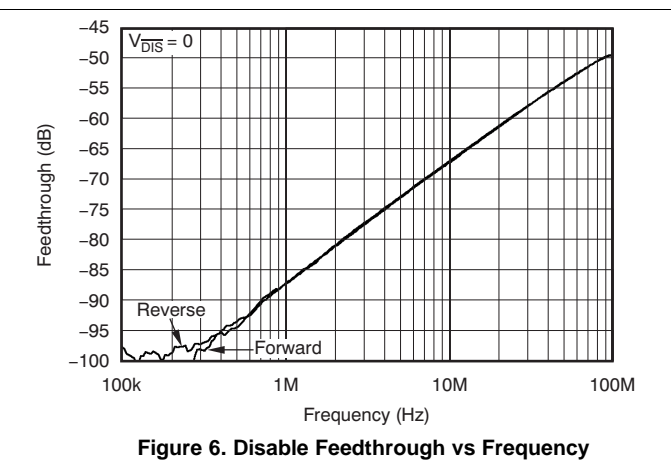
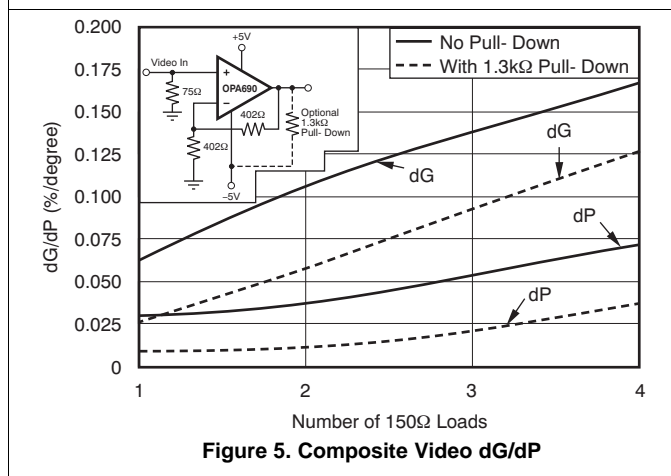
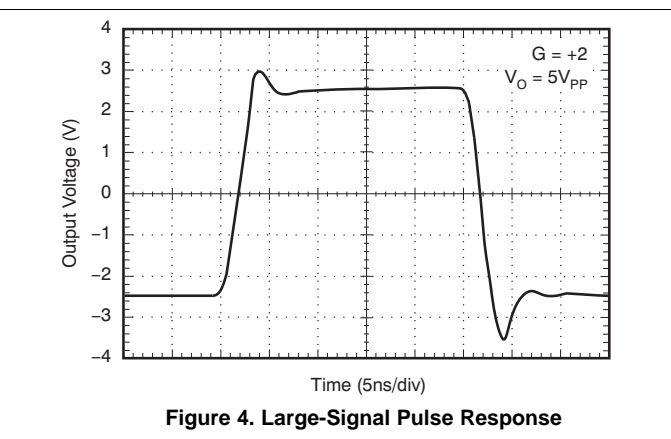
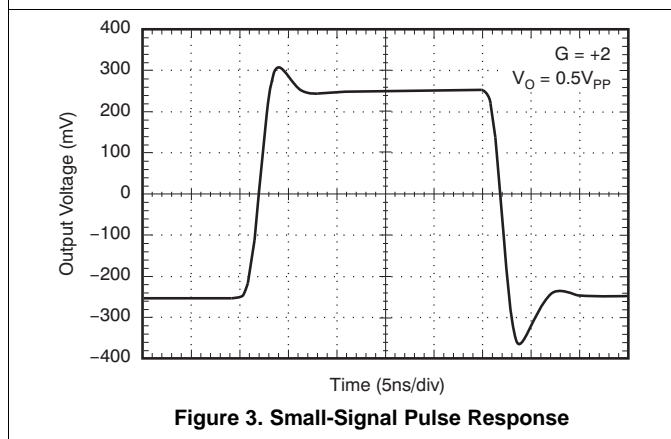
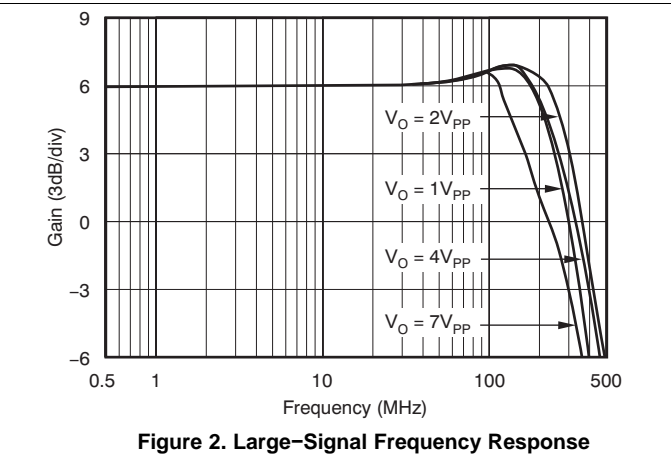
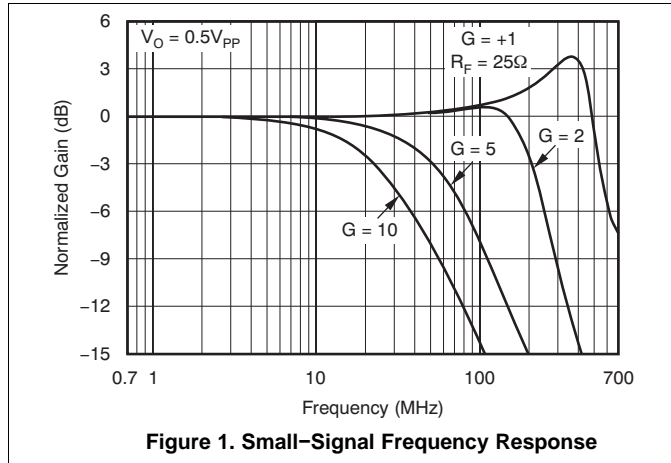

Typical Characteristics: $V_S = \pm 5\text{ V}$ (continued)

$T_A = 25^\circ\text{C}$, $G = 2$, $R_F = 402\ \Omega$, and $R_L = 100\ \Omega$; see [Figure 36](#) for AC performance only (unless otherwise noted)

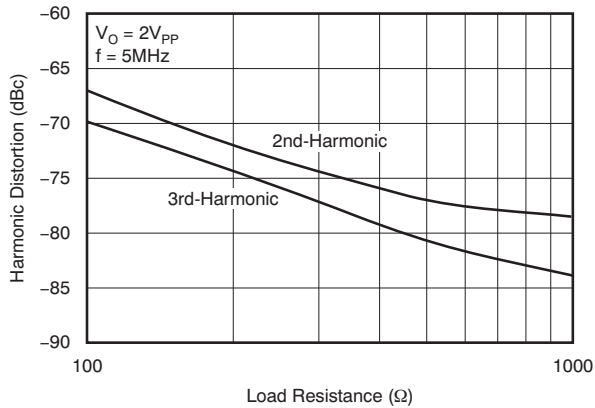

Figure 7. Harmonic Distortion vs Load Resistance

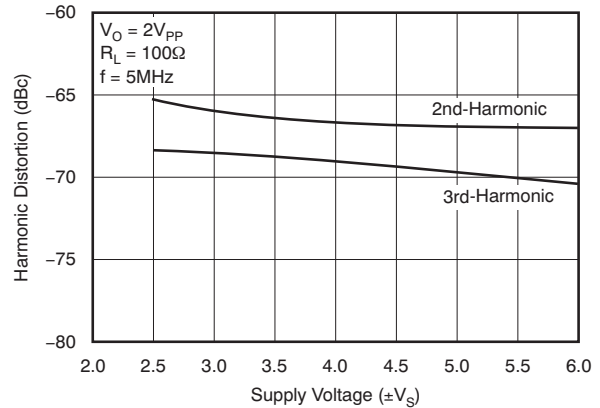

Figure 8. 5-MHz Harmonic Distortion vs Supply Voltage

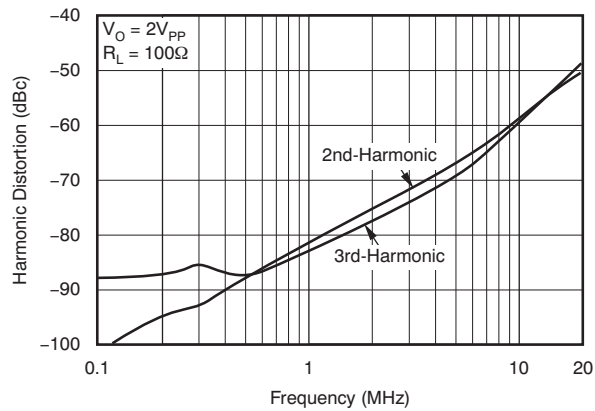

Figure 9. Harmonic Distortion vs Frequency

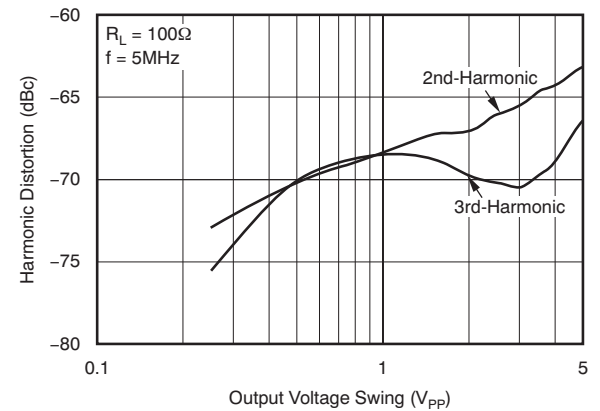

Figure 10. Harmonic Distortion vs Output Voltage

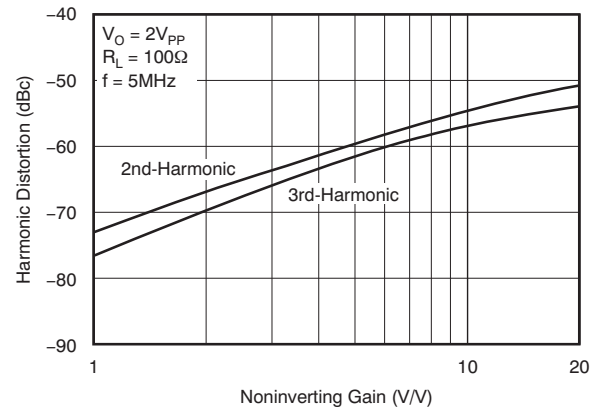

Figure 11. Harmonic Distortion vs Noninverting Gain

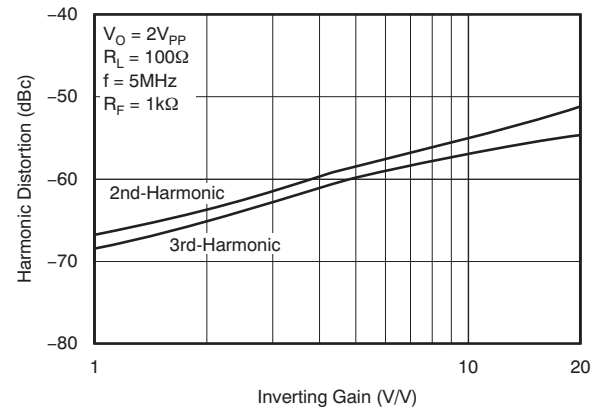

Figure 12. Harmonic Distortion vs Inverting Gain

Typical Characteristics: $V_S = \pm 5\text{ V}$ (continued)

$T_A = 25^\circ\text{C}$, $G = 2$, $R_F = 402\ \Omega$, and $R_L = 100\ \Omega$; see Figure 36 for AC performance only (unless otherwise noted)

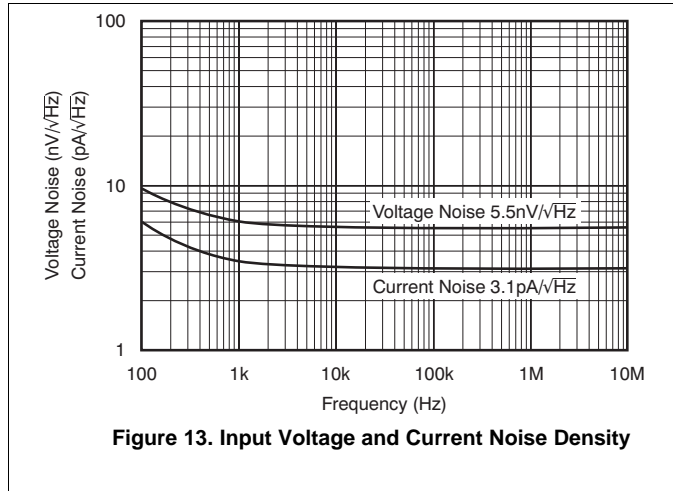

Figure 13. Input Voltage and Current Noise Density

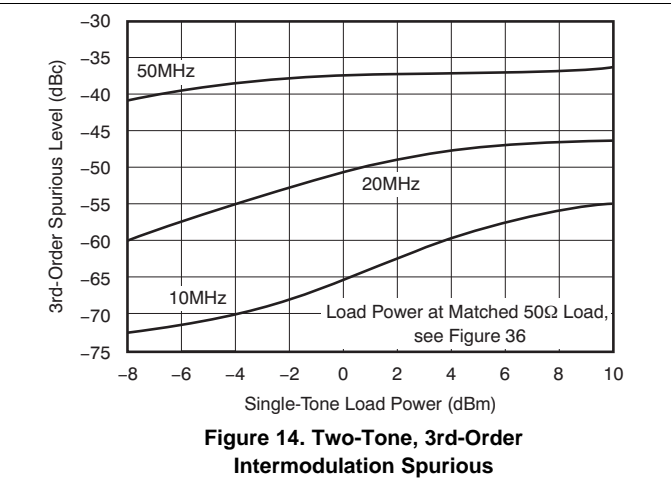

Figure 14. Two-Tone, 3rd-Order Intermodulation Spurious

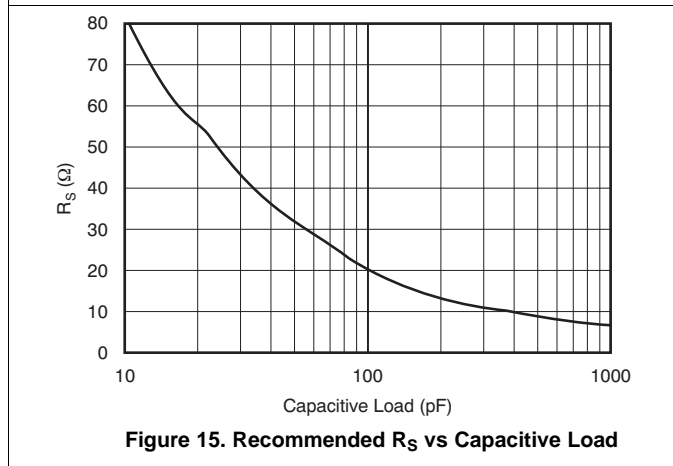

Figure 15. Recommended R_S vs Capacitive Load

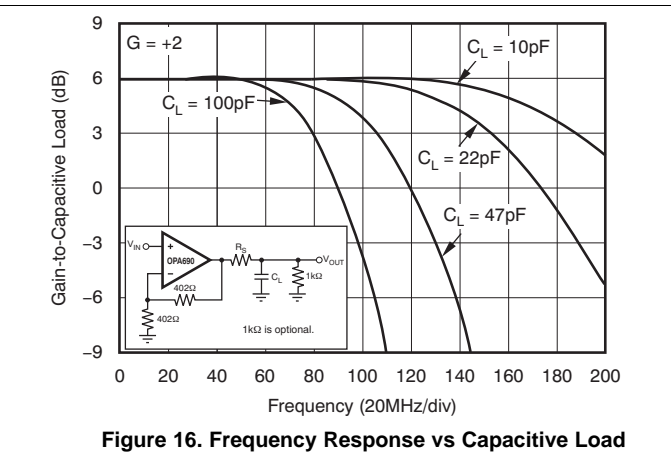

Figure 16. Frequency Response vs Capacitive Load

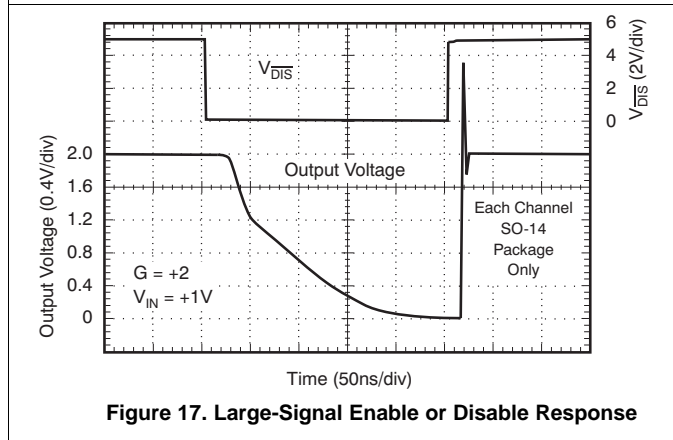

Figure 17. Large-Signal Enable or Disable Response

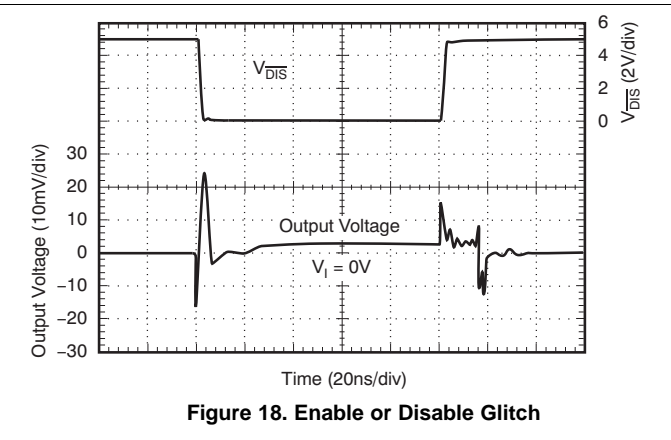

Figure 18. Enable or Disable Glitch

Typical Characteristics: $V_S = \pm 5\text{ V}$ (continued)

$T_A = 25^\circ\text{C}$, $G = 2$, $R_F = 402\ \Omega$, and $R_L = 100\ \Omega$; see Figure 36 for AC performance only (unless otherwise noted)

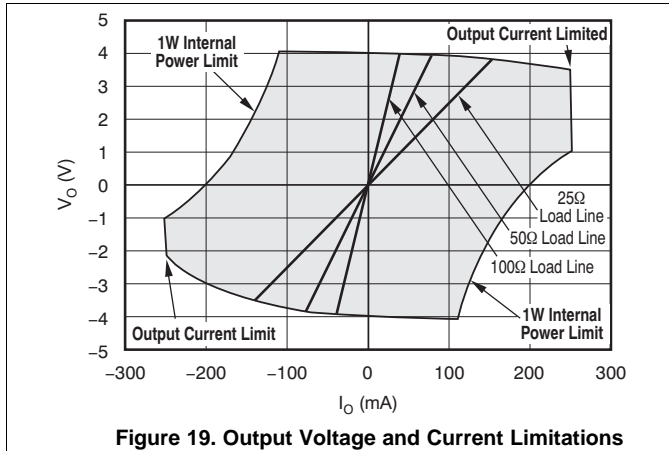

Figure 19. Output Voltage and Current Limitations

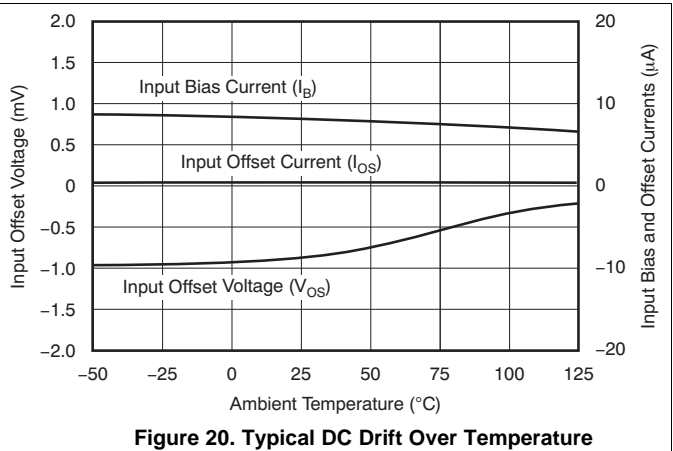

Figure 20. Typical DC Drift Over Temperature

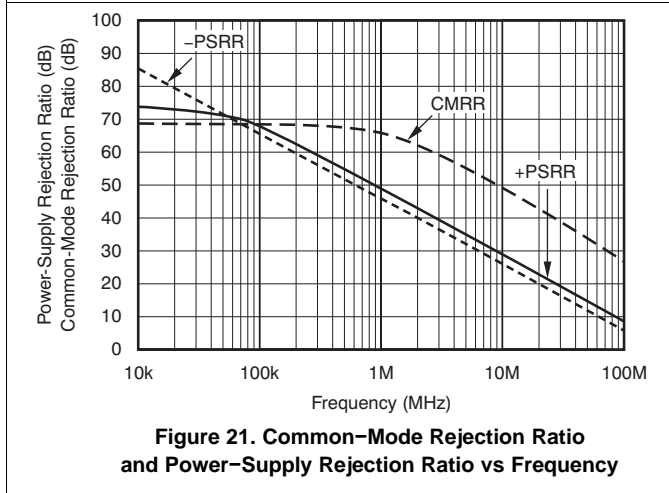

Figure 21. Common-Mode Rejection Ratio and Power-Supply Rejection Ratio vs Frequency

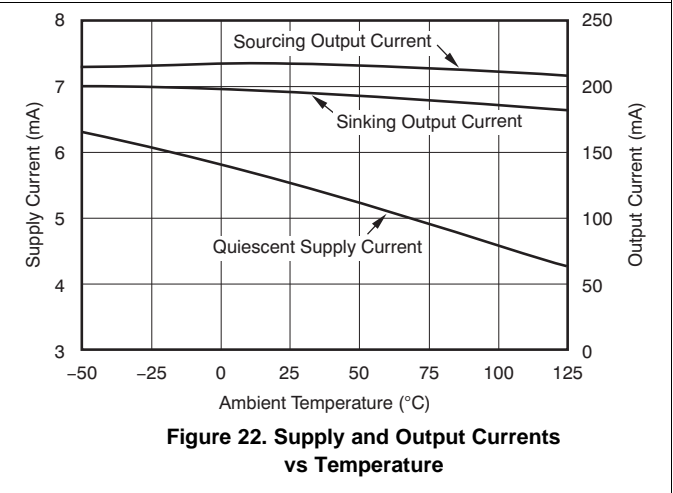

Figure 22. Supply and Output Currents vs Temperature

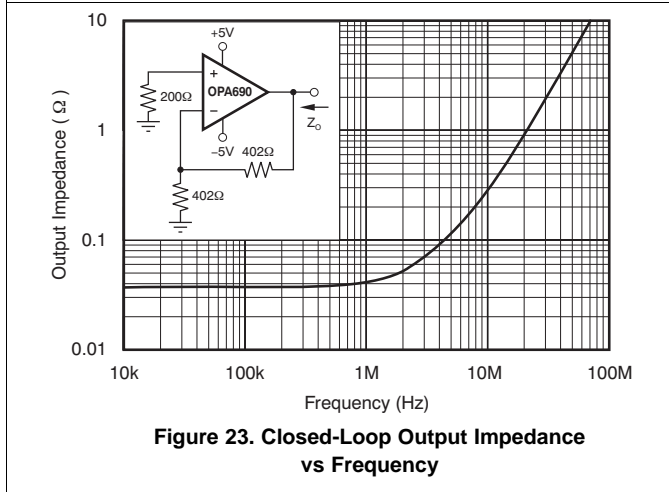

Figure 23. Closed-Loop Output Impedance vs Frequency

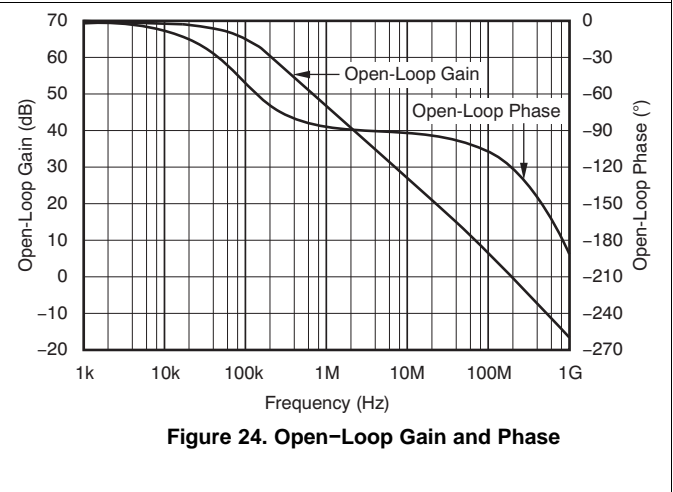
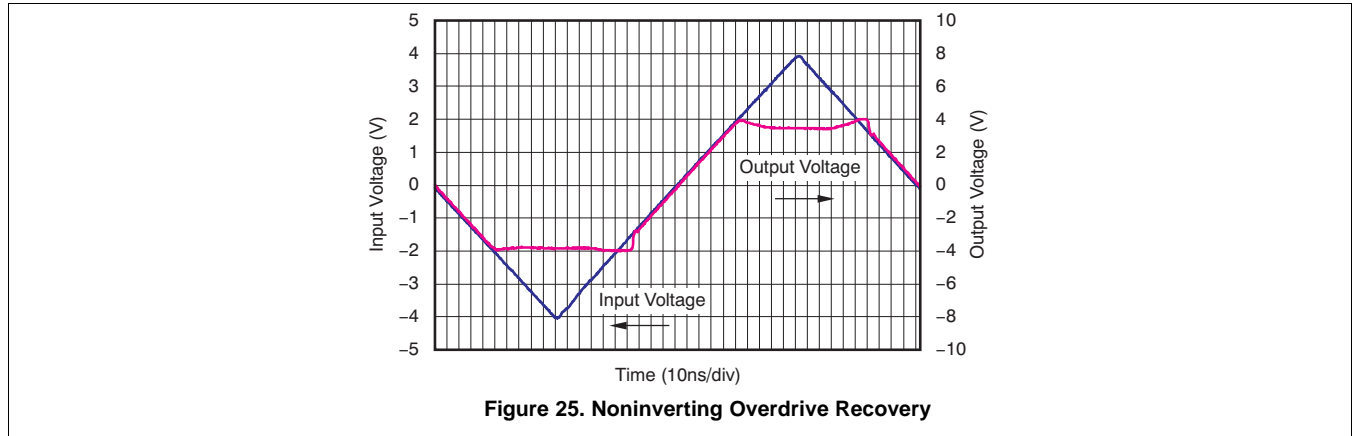

Figure 24. Open-Loop Gain and Phase

Typical Characteristics: $V_S = \pm 5\text{ V}$ (continued)

$T_A = 25^\circ\text{C}$, $G = 2$, $R_F = 402\ \Omega$, and $R_L = 100\ \Omega$; see Figure 36 for AC performance only (unless otherwise noted)



7.7.2 Typical Characteristics: 5 V

$T_A = 25^\circ\text{C}$, $G = 2$, $R_F = 402\ \Omega$, and $R_L = 100\ \Omega$; see Figure 37 for AC performance only (unless otherwise noted)

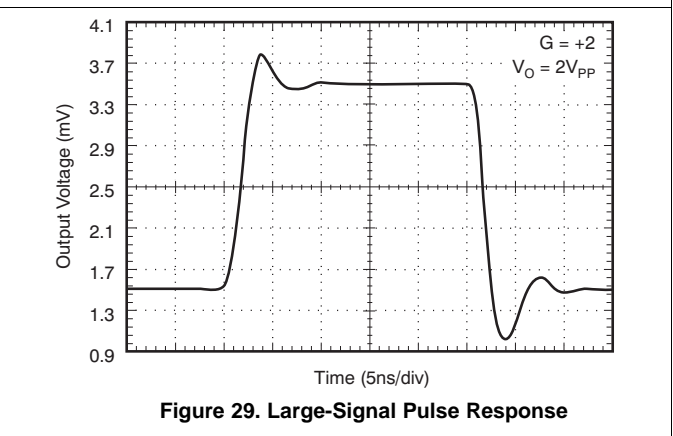
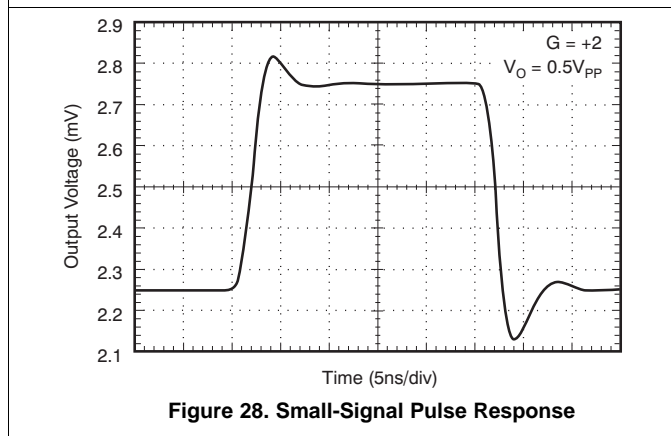
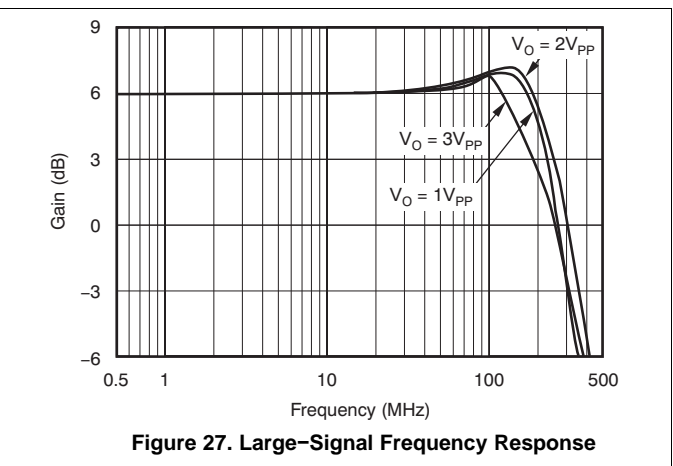
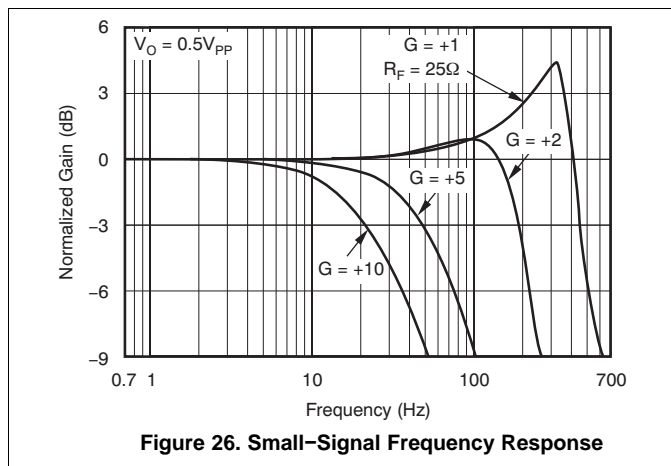

Typical Characteristics: 5 V (continued)

$T_A = 25^\circ\text{C}$, $G = 2$, $R_F = 402\ \Omega$, and $R_L = 100\ \Omega$; see Figure 37 for AC performance only (unless otherwise noted)

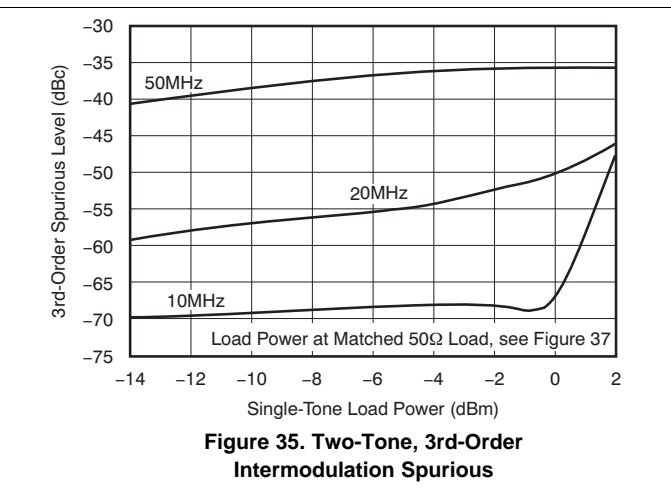
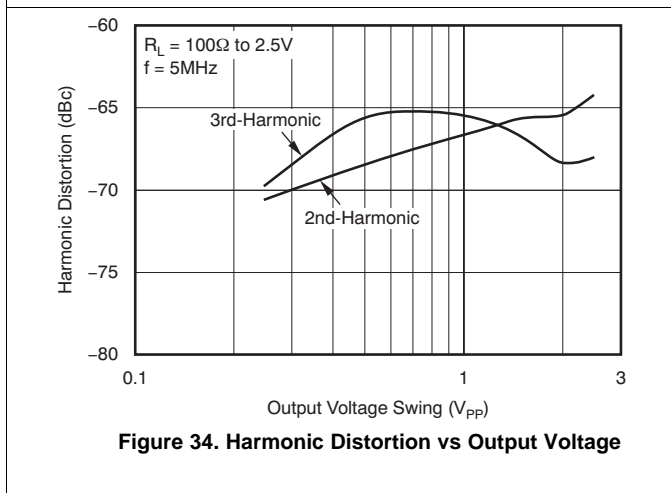
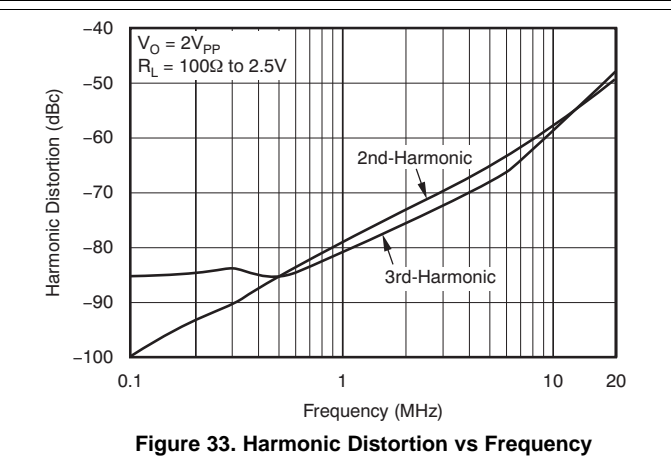
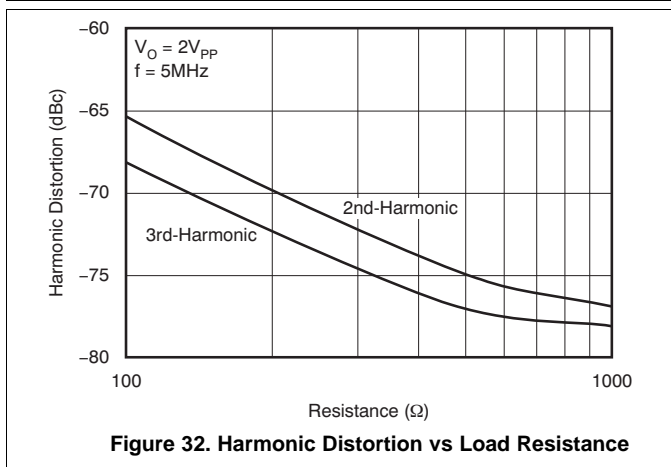
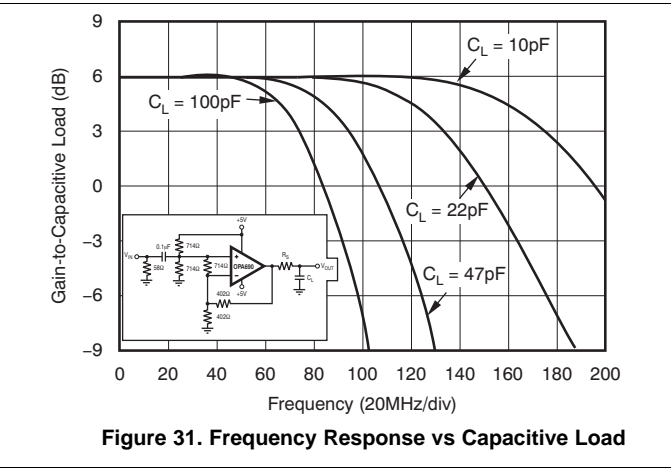
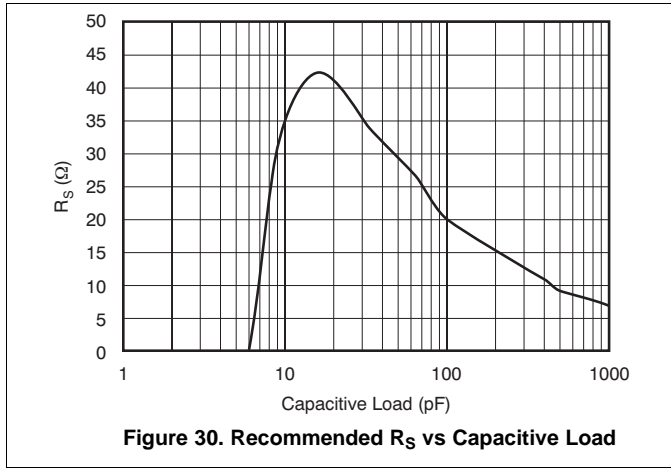

8 Detailed Description

8.1 Overview

The OPA690 provides an exceptional combination of high output power capability with a wideband, unity-gain stable voltage-feedback op amp using a new high slew rate input stage. The input stage provides a very high slew rate (1800 V/ μ s) while consuming relatively low quiescent current (5.5 mA). This exceptional full-power performance comes at the price of a slightly higher input noise voltage than alternative architectures. The 5.5-nV/ $\sqrt{\text{Hz}}$ input voltage noise for the OPA690 is exceptionally low for this type of input stage.

8.2 Functional Block Diagram

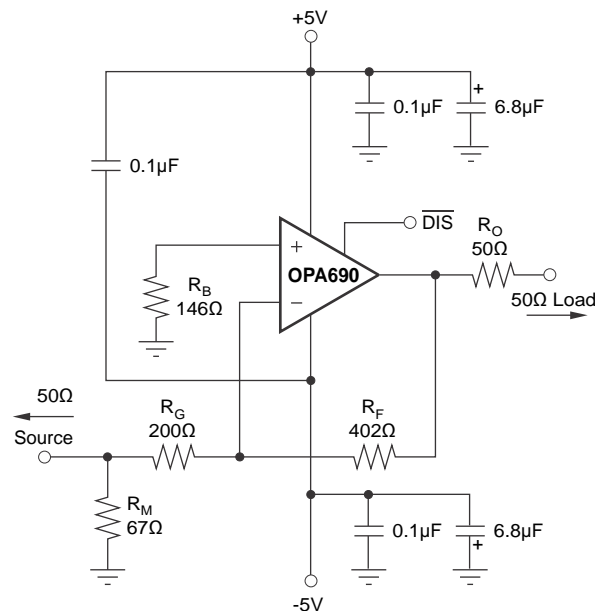

Copyright © 2016, Texas Instruments Incorporated

8.3 Feature Description

8.3.1 Wideband Voltage-Feedback Operation

Typical differential input stages used for voltage feedback op amps are designed to steer a fixed-bias current to the compensation capacitor, setting a limit to the achievable slew rate. The OPA690 uses a new input stage which places the transconductance element between two input buffers, using their output currents as the forward signal.

Figure 36 shows the DC-coupled, gain of 2, dual power supply circuit configuration used as the basis of the ± 5 V and *Typical Characteristics: $V_S = \pm 5$ V*. For test purposes, the input impedance is set to 50 Ω with a resistor to ground and the output impedance is set to 50 Ω with a series output resistor. Voltage swings reported in the specifications are taken directly at the input and output pins, while output powers (dBm) are at the matched 50- Ω load. For the circuit of Figure 36, the total effective load is 100 Ω || 804 Ω . The disable control line is typically left open to ensure normal amplifier operation. Two optional components are included in Figure 36. An additional resistor (175 Ω) is included in series with the noninverting input. Combined with the 25- Ω DC source resistance looking back towards the signal generator, this gives an input bias current cancelling resistance that matches the 200- Ω source resistance seen at the inverting input (see *DC Accuracy and Offset Control*). In addition to the usual power-supply decoupling capacitors to ground, a 0.1- μ F capacitor is included between the two power-supply pins. In practical printed-circuit board (PCB) layouts, this optional-added capacitor typically improves the 2nd-harmonic distortion performance by 3 dB to 6 dB.

Feature Description (continued)

Figure 37 shows the AC-coupled, gain of 2, single-supply circuit configuration which is the basis of the 5 V and *Typical Characteristics: 5 V*. Though not a rail-to-rail design, the OPA690 requires minimal input and output voltage headroom compared to other very wideband voltage-feedback op amps. It delivers a 3-V_{PP} output swing on a single 5-V supply with > 150-MHz bandwidth. The key requirement of broadband single-supply operation is to maintain input and output signal swings within the useable voltage ranges at both the input and the output. The circuit of Figure 37 establishes an input midpoint bias using a simple resistive divider from the 5-V supply (two 698-Ω resistors). The input signal is then AC-coupled into the midpoint voltage bias. The input voltage can swing to within 1.5 V of either supply pin, giving a 2-V_{PP} input signal range centered between the supply pins. The input impedance matching resistor (59 Ω) used for testing is adjusted to give a 50-Ω input load when the parallel combination of the biasing divider network is included.

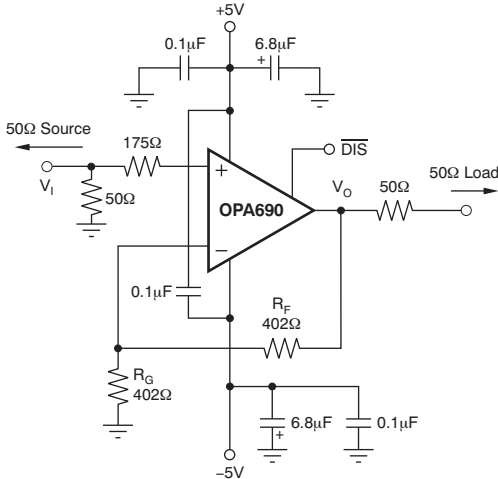

Figure 36. DC-Coupled, G = 2, Bipolar-Supply Specification and Test Circuit

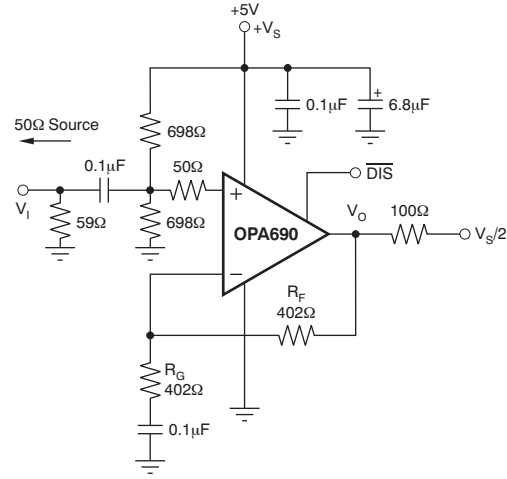

Figure 37. AC-Coupled, G = 2, Single-Supply Specification and Test Circuit

Again, an additional resistor (50 Ω in this case) is included directly in series with the noninverting input. This minimum recommended value provides part of the dc source resistance matching for the noninverting input bias current. It is also used to form a simple parasitic pole to roll off the frequency response at very high frequencies (> 500 MHz) using the input parasitic capacitance to form a bandlimiting pole. The gain resistor (R_G) is AC-coupled, giving the circuit a DC gain of 1, which puts the input DC bias voltage (2.5 V) at the output as well. The output voltage can swing to within 1 V of either supply pin while delivering > 100-mA output current. A demanding 100-Ω load to a midpoint bias is used in this characterization circuit. The new output stage circuit used in the OPA690 can deliver large bipolar output currents into this midpoint load with minimal crossover distortion, as shown in the 5-V supply, 3rd-harmonic distortion plots.

8.3.2 Bandwidth Versus Gain: Noninverting Operation

Voltage-feedback op amps exhibit decreasing closed-loop bandwidth as the signal gain is increased. In theory, this relationship is described by the gain bandwidth product (GBP) shown in the *Electrical Characteristics: V_S = ±5 V*. Ideally, dividing GBP by the noninverting signal gain (also called the Noise Gain, or NG) predicts the closed-loop bandwidth. In practice, this only holds true when the phase margin approaches 90°, as it does in high gain configurations. At low gains (increased feedback factors), most amplifiers exhibit a more complex response with lower phase margin. The OPA690 is compensated to give a slightly peaked response in a noninverting gain of 2 (see Figure 36). This results in a typical gain of 2 bandwidth of 220 MHz, far exceeding that predicted by dividing the 300 MHz GBP by 2. Increasing the gain causes the phase margin to approach 90° and the bandwidth to more closely approach the predicted value of (GBP/NG). At a gain of 10, the 30-MHz bandwidth shown in *Electrical Characteristics: V_S = ±5 V* agrees with that predicted using the simple formula and the typical GBP of 300 MHz.

Feature Description (continued)

The frequency response in a gain of 2 may be modified to achieve exceptional flatness simply by increasing the noise gain to 2.5. One way to do this, without affecting the 2 signal gain, is to add an 804- Ω resistor across the two inputs in the circuit of Figure 36. A similar technique may be used to reduce peaking in unity-gain (voltage follower) applications. For example, by using a 402- Ω feedback resistor along with a 402- Ω resistor across the two op amp inputs, the voltage follower response is similar to the gain of 2 response of Figure 37. Reducing the value of the resistor across the op amp inputs further limits the frequency response due to increased noise gain.

The OPA690 exhibits minimal bandwidth reduction going to single-supply (5 V) operation as compared with ± 5 V. This is because the internal bias control circuitry retains nearly constant quiescent current as the total supply voltage between the supply pins is changed.

8.3.3 Inverting Amplifier Operation

Because the OPA690 is a general-purpose, wideband voltage-feedback op amp, all of the familiar op amp application circuits are available to the designer. Inverting operation is one of the more common requirements and offers several performance benefits. Figure 38 shows a typical inverting configuration where the I/O impedances and signal gain from Figure 36 are retained in an inverting circuit configuration.

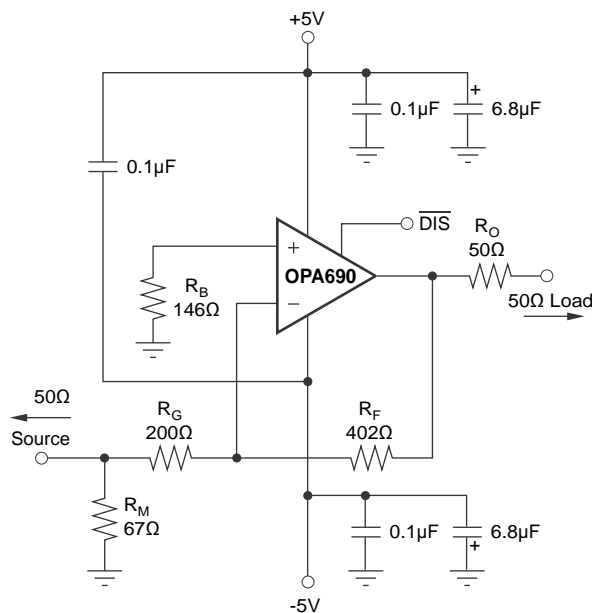

Copyright © 2016, Texas Instruments Incorporated

Figure 38. Gain of -2 Example Circuit

In the inverting configuration, three key design considerations must be noted. The first is that the gain resistor (R_G) becomes part of the signal channel input impedance. If input impedance matching is desired (which is beneficial whenever the signal is coupled through a cable, twisted-pair, long PCB trace, or other transmission line conductor), R_G may be set equal to the required termination value and R_F adjusted to give the desired gain. This is the simplest approach and results in optimum bandwidth and noise performance. However, at low inverting gains, the resultant feedback resistor value can present a significant load to the amplifier output. For an inverting gain of 2, setting R_G to 50 Ω for input matching eliminates the requirement for R_M but requires a 100- Ω feedback resistor. This has the interesting advantage that the noise gain becomes equal to 2 for a 50- Ω source impedance—the same as the noninverting circuits considered in the previous section. The amplifier output, however, now sees the 100- Ω feedback resistor in parallel with the external load. In general, the feedback resistor must be limited to the 200- Ω to 1.5-k Ω range. In this case, it is preferable to increase both the R_F and R_G values, as shown in Figure 38, and then achieve the input matching impedance with a third resistor (R_M) to ground. The total input impedance becomes the parallel combination of R_G and R_M .

Feature Description (continued)

The second major consideration, touched on in the previous paragraph, is that the signal source impedance becomes part of the noise gain equation and influences the bandwidth. For the example in [Figure 38](#), the R_M value combines in parallel with the external 50- Ω source impedance, yielding an effective driving impedance of $50\ \Omega \parallel 67\ \Omega = 28.6\ \Omega$. This impedance is added in series with R_G for calculating the noise gain (NG). The resultant NG is 2.8 for [Figure 38](#), as opposed to only 2 if R_M could be eliminated as discussed above. Therefore, the bandwidth is slightly lower for the gain of ± 2 circuit of [Figure 38](#) than for the gain of 2 circuit of [Figure 36](#).

The third important consideration in inverting amplifier design is setting the bias current cancellation resistor on the noninverting input (R_B). If this resistor is set equal to the total DC resistance looking out of the inverting node, the output DC error, due to the input bias currents, is reduced to (Input Offset Current) $\times R_F$. If the 50- Ω source impedance is DC-coupled in [Figure 38](#), the total resistance to ground on the inverting input is 228 Ω . Combining this in parallel with the feedback resistor gives the $R_B = 146\ \Omega$ used in this example. To reduce the additional high-frequency noise introduced by this resistor, it is sometimes bypassed with a capacitor. As long as $R_B < 350\ \Omega$, the capacitor is not required because the total noise contribution of all other terms is less than that of the op amp input noise voltage. As a minimum, the OPA690 requires an R_B value of 50 Ω to damp out parasitic-induced peaking which is a direct short to ground on the noninverting input runs the risk of a very high-frequency instability in the input stage.

8.3.4 Output Current and Voltage

The OPA690 provides output voltage and current capabilities that are unsurpassed in a low-cost monolithic op amp. Under no-load conditions at 25°C, the output voltage typically swings closer than 1 V to either supply rail; the specified swing limit is within 1.2 V of either rail. Into a 15- Ω load (the minimum tested load), it delivers more than ± 160 mA.

The specifications described previously, though familiar in the industry, consider voltage and current limits separately. In many applications, it is the voltage \times current, or V-I product, which is more relevant to circuit operation. Refer to [Figure 19](#), the Output Voltage and Current Limitations plot in *Typical Characteristics: $V_S = \pm 5$ V*. The X- and Y-axes of this graph show the zero-voltage output current limit and the zero-current output voltage limit, respectively. The four quadrants give a more detailed view of the OPA690 output drive capabilities, noting that the graph is bounded by a safe operating area of 1-W maximum internal power dissipation. Superimposing resistor load lines onto the plot shows that the OPA690 can drive ± 2.5 V into 25 Ω or ± 3.5 V into 50 Ω without exceeding the output capabilities or the 1-W dissipation limit. A 100- Ω load line (the standard test circuit load) shows the full ± 3.9 -V output swing capability, as shown in *Typical Characteristics: $V_S = \pm 5$ V*.

The minimum specified output voltage and current specifications over temperature are set by worst-case simulations at the cold temperature extreme. Only at cold startup will the output current and voltage decrease to the numbers shown in *Electrical Characteristics: $V_S = \pm 5$ V*. As the output transistors deliver power, their junction temperatures increase, decreasing their V_{BEs} (increasing the available output voltage swing) and increasing their current gains (increasing the available output current). In steady-state operation, the available output voltage and current is always greater than that shown in the overtemperature specifications because the output stage junction temperatures is higher than the minimum specified operating ambient.

To protect the output stage from accidental shorts to ground and the power supplies, output short-circuit protection is included in the OPA690. The circuit acts to limit the maximum source or sink current to approximately 250 mA.

8.3.5 Driving Capacitive Loads

One of the most demanding and yet very common load conditions for an op amp is capacitive loading. Often, the capacitive load is the input of an ADC—including additional external capacitance which may be recommended to improve ADC linearity. A high-speed, high open-loop gain amplifier like the OPA690 can be very susceptible to decreased stability and closed-loop response peaking when a capacitive load is placed directly on the output pin. When the amplifier's open-loop output resistance is considered, this capacitive load introduces an additional pole in the signal path that can decrease the phase margin. Several external solutions to this problem have been suggested. When the primary considerations are frequency response flatness, pulse response fidelity, and distortion, the simplest and most effective solution is to isolate the capacitive load from the feedback loop by inserting a series-isolation resistor between the amplifier output and the capacitive load. This does not eliminate the pole from the loop response, but rather shifts it and adds a zero at a higher frequency. The additional zero acts to cancel the phase lag from the capacitive load pole, thus increasing the phase margin and improving stability.

Feature Description (continued)

The typical characteristics show the recommended R_S versus capacitive load (Figure 15 for ± 5 V and Figure 30 for 5 V) and the resulting frequency response at the load. Parasitic capacitive loads greater than 2 pF can begin to degrade the performance of the OPA690. Long PCB traces, unmatched cables, and connections to multiple devices can easily exceed this value. Always consider this effect carefully, and add the recommended series resistor as close as possible to the OPA690 output pin (see *Layout Guidelines*).

The criterion for setting this R_S resistor is a maximum bandwidth, flat frequency response at the load. For the OPA690 operating in a gain of 2, the frequency response at the output pin is already slightly peaked without the capacitive load requiring relatively high values of R_S to flatten the response at the load. Increasing the noise gain reduces the peaking as described previously. The circuit of Figure 39 demonstrates this technique, allowing lower values of R_S to be used for a given capacitive load.

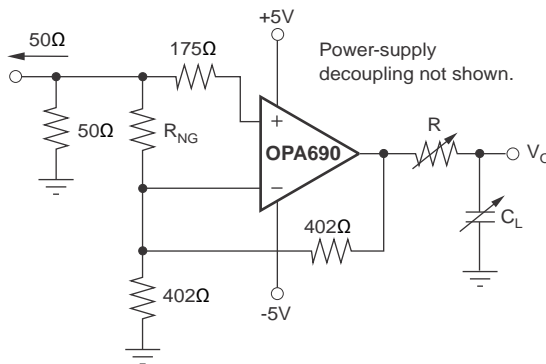

Copyright © 2016, Texas Instruments Incorporated

Figure 39. Capacitive Load Driving With Noise Gain Tuning

This gain of 2 circuit includes a noise gain tuning resistor across the two inputs to increase the noise gain, increasing the unloaded phase margin for the op amp. Although this technique reduces the required R_S resistor for a given capacitive load, it does increase the noise at the output. It also decreases the loop gain, slightly decreasing the distortion performance. If, however, the dominant distortion mechanism arises from a high R_S value, significant dynamic range improvement can be achieved using this technique. Figure 40 shows the required R_S versus C_{LOAD} parametric on noise gain using this technique. This is the circuit of Figure 39 with R_{NG} adjusted to increase the noise gain (increasing the phase margin) then sweeping C_{LOAD} and finding the required R_S to get a flat frequency response. This plot also gives the required R_S versus C_{LOAD} for the OPA690 operated at higher signal gains.

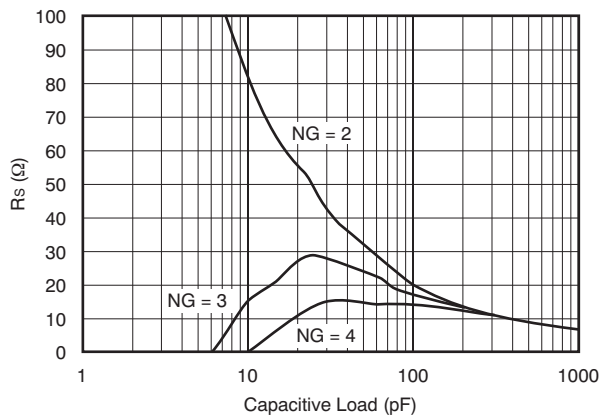

Figure 40. Required R_S vs Noise Gain

Feature Description (continued)

8.3.6 Distortion Performance

The OPA690 provides good distortion performance into a 100-Ω load on ±5-V supplies. Relative to alternative solutions, it provides exceptional performance into lighter loads and/or operating on a single 5-V supply. Generally, until the fundamental signal reaches very high frequency or power levels, the 2nd-harmonic dominates the distortion with a negligible 3rd-harmonic component. Focusing then on the 2nd-harmonic, increasing the load impedance improves distortion directly. Remember that the total load includes the feedback network; in the noninverting configuration (see Figure 36), this is sum of $R_F + R_G$, while in the inverting configuration it is just R_F . Also, providing an additional supply-decoupling capacitor (0.1 μF) between the supply pins (for bipolar operation) improves the 2nd-order distortion slightly (3 dB to 6 dB).

In most op amps, increasing the output voltage swing increases harmonic distortion directly. The new output stage used in the OPA690 actually holds the difference between fundamental power and the 2nd- and 3rd-harmonic powers relatively constant with increasing output power until very large output swings are required ($> 4 V_{PP}$). This also shows up in the 2-tone, 3rd-order intermodulation spurious (IM3) response curves. The 3rd-order spurious levels are moderately low at low output power levels. The output stage continues to hold them low even as the fundamental power reaches very high levels. As the *Typical Characteristics: $V_S = \pm 5 V$* show, the spurious intermodulation powers do not increase as predicted by a traditional intercept model. As the fundamental power level increases, the dynamic range does not decrease significantly. For two tones centered at 20 MHz, with 10 dBm/tone into a matched 50-Ω load (that is, 2 V_{PP} for each tone at the load, which requires 8 V_{PP} for the overall two-tone envelope at the output pin), Figure 14 shows 47-dBc difference between the test tone powers and the 3rd-order intermodulation spurious powers. This performance improves further when operating at lower frequencies.

8.3.7 Noise Performance

High slew rate, unity-gain stable, voltage-feedback op amps usually achieve their slew rate at the expense of a higher input noise voltage. The 5.5-nV/√Hz input voltage noise for the OPA690 is, however, much lower than comparable amplifiers. The input-referred voltage noise, and the two input-referred current noise terms, combine to give low output noise under a wide variety of operating conditions. Figure 41 shows the op amp noise analysis model with all the noise terms included. In this model, all noise terms are taken to be noise voltage or current density terms in either nV/√Hz or pA/√Hz.

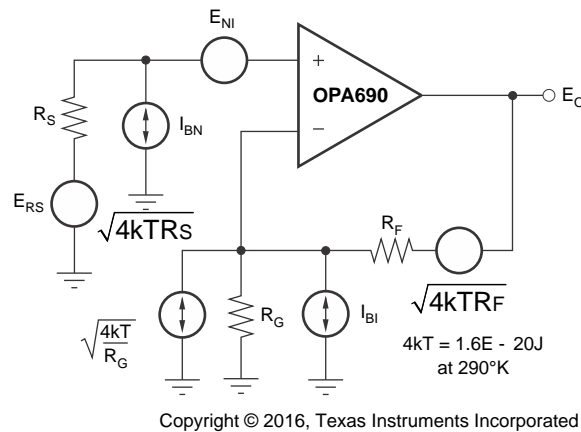

Figure 41. Op Amp Noise Analysis Model

The total output spot noise voltage can be computed as the square root of the sum of all squared output noise voltage contributors. Equation 1 shows the general form for the output noise voltage using the terms shown in Figure 41.

$$E_O = \sqrt{\left(E_{NI}^2 + (I_{BN}R_S)^2 + 4kTR_S \right) NG^2 + (I_{BI}R_F)^2 + 4kTR_F NG} \tag{1}$$

Dividing this expression by the noise gain [$NG = (1 + R_F/R_G)$] gives the equivalent input-referred spot noise voltage at the noninverting input, as shown in Equation 2.

Feature Description (continued)

$$E_N = \sqrt{E_{NI}^2 + (I_{BN}R_S)^2 + 4kTR_S + \left(\frac{I_{BI}R_F}{NG}\right)^2 + \frac{4kTR_F}{NG}} \quad (2)$$

Evaluating these two equations for the OPA690 circuit and component values (see [Figure 36](#)) gives a total output spot noise voltage of 12.3 nV/√Hz and a total equivalent input spot noise voltage of 6.1 nV/√Hz. This is including the noise added by the bias current cancellation resistor (175 Ω) on the noninverting input. This total input-referred spot noise voltage is only slightly higher than the 5.5-nV/√Hz specification for the op amp voltage noise alone. This is the case as long as the impedances appearing at each op amp input are limited to the previously recommend maximum value of 300 Ω. Keeping both (R_F || R_G) and the noninverting input source impedance less than 300 Ω satisfies both noise and frequency response flatness considerations. Because the resistor-induced noise is relatively negligible, additional capacitive decoupling across the bias current cancellation resistor (R_B) for the inverting op amp configuration of [Figure 38](#) is not required.

8.3.8 DC Accuracy and Offset Control

The balanced input stage of a wideband voltage-feedback op amp allows good output DC accuracy in a wide variety of applications. The power-supply current trim for the OPA690 gives even tighter control than comparable amplifiers. Although the high-speed input stage does require relatively high input bias current (typically ±8 μA at each input terminal), the close matching between them may be used to reduce the output DC error caused by this current. The total output offset voltage may be considerably reduced by matching the DC source resistances appearing at the two inputs. This reduces the output dc error due to the input bias currents to the offset current times the feedback resistor. Evaluating the configuration of [Figure 36](#), and using worst-case 25°C input offset voltage and current specifications, gives a worst-case output offset voltage equal to:

$$\begin{aligned} &-(NG = \text{noninverting signal gain}) \\ &\pm(NG \times V_{OS(\text{MAX})}) \pm (R_F \times I_{OS(\text{MAX})}) \\ &= \pm(2 \times 4 \text{ mV}) \pm (402 \Omega \times 1 \mu\text{A}) \\ &= \pm 8.4 \text{ mV} \end{aligned}$$

A fine-scale output offset null, or DC operating point adjustment, is often required. Numerous techniques are available for introducing DC offset control into an op amp circuit. Most of these techniques eventually reduce to adding a DC current through the feedback resistor. In selecting an offset trim method, one key consideration is the impact on the desired signal path frequency response. If the signal path is intended to be noninverting, the offset control is best applied as an inverting summing signal to avoid interaction with the signal source. If the signal path is intended to be inverting, applying the offset control to the noninverting input may be considered. However, the DC offset voltage on the summing junction sets up a DC current back into the source that must be considered. Applying an offset adjustment to the inverting op amp input can change the noise gain and frequency response flatness. For a DC-coupled inverting amplifier, see [Figure 42](#) for one example of an offset adjustment technique that has minimal impact on the signal frequency response. In this case, the DC offsetting current is brought into the inverting input node through resistor values that are much larger than the signal path resistors. This ensures that the adjustment circuit has minimal effect on the loop gain and hence, the frequency response.

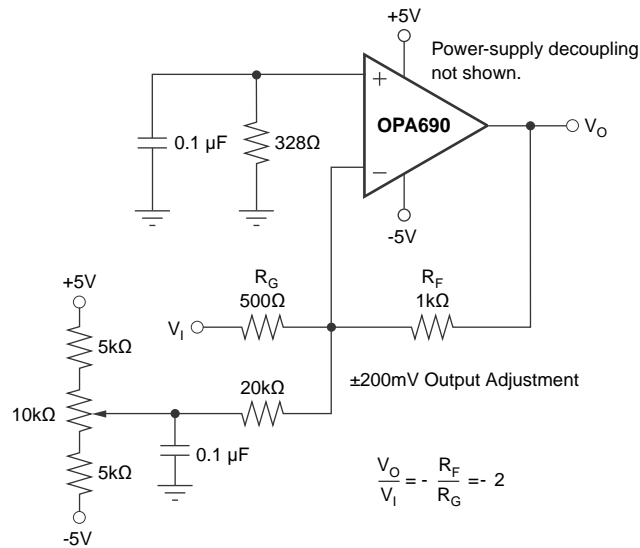
Feature Description (continued)

Copyright © 2016, Texas Instruments Incorporated

Figure 42. DC-Coupled, Inverting Gain of –2, With Offset Adjustment
8.4 Device Functional Modes
8.4.1 Disable Operation

The OPA690 provides an optional disable feature that may be used either to reduce system power or to implement a simple channel multiplexing operation. If the $\overline{\text{DIS}}$ control pin is left unconnected, the OPA690 operates normally. To disable, the control pin must be asserted LOW. Figure 43 shows a simplified internal circuit for the disable control feature.

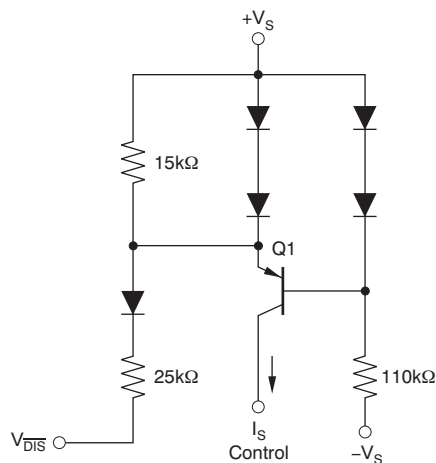
Figure 43. Simplified Disable Control Circuit

Device Functional Modes (continued)

In normal operation, base current to Q1 is provided through the 110-k Ω resistor, while the emitter current through the 15-k Ω resistor sets up a voltage drop that is inadequate to turn on the two diodes in Q1's emitter. As $\overline{V_{DIS}}$ is pulled LOW, additional current is pulled through the 15-k Ω resistor, eventually turning on those two diodes (approximately 75 μ A). At this point, any further current pulled out of $\overline{V_{DIS}}$ goes through those diodes holding the emitter-base voltage of Q1 at approximately 0 V. This shuts off the collector current out of Q1, turning the amplifier off. The supply current in the disable mode are only those required to operate the circuit of Figure 43. Additional circuitry ensures that turnon time occurs faster than turnoff time (make-before-break).

When disabled, the output and input nodes go to a high-impedance state. If the OPA690 is operating at a gain of 1, this shows a very high impedance at the output and exceptional signal isolation. If operating at a gain greater than 1, the total feedback network resistance ($R_F + R_G$) appears as the impedance looking back into the output, but the circuit still shows very high forward and reverse isolation. If configured as an inverting amplifier, the input and output is connected through the feedback network resistance ($R_F + R_G$) and the isolation is very poor as a result.

One key parameter in disable operation is the output glitch when switching in and out of the disabled mode. Figure 44 shows these glitches for the circuit of Figure 36 with the input signal at 0 V. The glitch waveform at the output pin is plotted along with the \overline{DIS} pin voltage.

The transition edge rate (dV/dt) of the \overline{DIS} control line influences this glitch. For the plot of Figure 44, the edge rate was reduced until no further reduction in glitch amplitude was observed. This approximately 1-V/ns maximum slew rate may be achieved by adding a simple RC filter into the \overline{DIS} pin from a higher speed logic line. If extremely fast transition logic is used, a 1-k Ω series resistor between the logic gate and the \overline{DIS} input pin provides adequate bandlimiting using just the parasitic input capacitance on the \overline{DIS} pin while still ensuring adequate logic level swing.

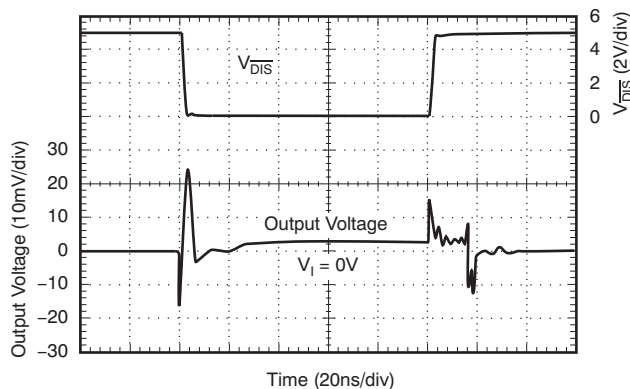

Figure 44. Disable or Enable Glitch

9 Application and Implementation

NOTE

Information in the following applications sections is not part of the TI component specification, and TI does not warrant its accuracy or completeness. TI's customers are responsible for determining suitability of components for their purposes. Customers should validate and test their design implementation to confirm system functionality.

9.1 Application Information

9.1.1 Optimizing Resistor Values

Because the OPA690 is a unity-gain stable, voltage-feedback op amp, a wide range of resistor values may be used for the feedback and gain setting resistors. The primary limits on these values are set by dynamic range (noise and distortion) and parasitic capacitance considerations. For a noninverting unity-gain follower application, the feedback connection must be made with a 25-Ω resistor, not a direct short. This isolates the inverting input capacitance from the output pin and improve the frequency response flatness. Usually, for $G > 1$ applications, the feedback resistor value must be between 200 Ω and 1.5 kΩ. Below 200 Ω, the feedback network presents additional output loading which can degrade the harmonic distortion performance of the OPA690. Above 1.5 kΩ, the typical parasitic capacitance (approximately 0.2 pF) across the feedback resistor may cause unintentional band-limiting in the amplifier response.

A good rule of thumb is to target the parallel combination of R_F and R_G (see [Figure 36](#)) to be less than approximately 300 Ω. The combined impedance $R_F \parallel R_G$ interacts with the inverting input capacitance, placing an additional pole in the feedback network and thus, a zero in the forward response. Assuming a 2-pF total parasitic on the inverting node, holding $R_F \parallel R_G < 300 \Omega$ keeps this pole above 250 MHz. By itself, this constraint implies that the feedback resistor R_F can increase to several kΩ at high gains. This is acceptable as long as the pole formed by R_F and any parasitic capacitance appearing in parallel is kept out of the frequency range of interest.

9.1.2 Thermal Analysis

Due to the high output power capability of the OPA690, heatsinking or forced airflow may be required under extreme operating conditions. Maximum desired junction temperature sets the maximum allowed internal power dissipation as described below. In no case must the maximum junction temperature be allowed to exceed 175°C.

Operating junction temperature (T_J) is given by $T_A + P_D \times R_{\theta JA}$. The total internal power dissipation (P_D) is the sum of quiescent power (P_{DQ}) and additional power dissipated in the output stage (P_{DL}) to deliver load power. Quiescent power is simply the specified no-load supply current times the total supply voltage across the part. P_{DL} depends on the required output signal and load but, for a grounded resistive load, be at a maximum when the output is fixed at a voltage equal to 1/2 of either supply voltage (for equal bipolar supplies) under the condition in [Equation 3](#).

$$P_{DL} = V_S^2 / (4 \times R_L)$$

where

- R_L includes feedback network loading (3)

NOTE

It is the power in the output stage and not into the load that determines internal power dissipation.

As a worst-case example, compute the maximum T_J using an OPA690-DBV (6-pin SOT-23 package) in the circuit of [Figure 36](#) operating at the maximum specified ambient temperature of 85°C and driving a grounded 20-Ω load.

$$P_D = 10 \text{ V} \times 6.2 \text{ mA} + 5^2 / (4 \times (20 \Omega \parallel 804 \Omega)) = 382 \text{ mW} \quad (4)$$

$$\text{Maximum } T_J = 85^\circ\text{C} + (0.38 \text{ W} \times 150^\circ\text{C/W}) = 142^\circ\text{C} \quad (5)$$

Application Information (continued)

Although this is still well below the specified maximum junction temperature, system reliability considerations may require lower tested junction temperatures. The highest possible internal dissipation occurs if the load requires current to be forced into the output for positive output voltages or sourced from the output for negative output voltages. This puts a high current through a large internal voltage drop in the output transistors. Figure 19, the output V-I plot shown in *Typical Characteristics: $V_S = \pm 5\text{ V}$* , include a boundary for 1-W maximum internal power dissipation under these conditions.

9.2 Typical Applications

9.2.1 Single-Supply ADC Interface

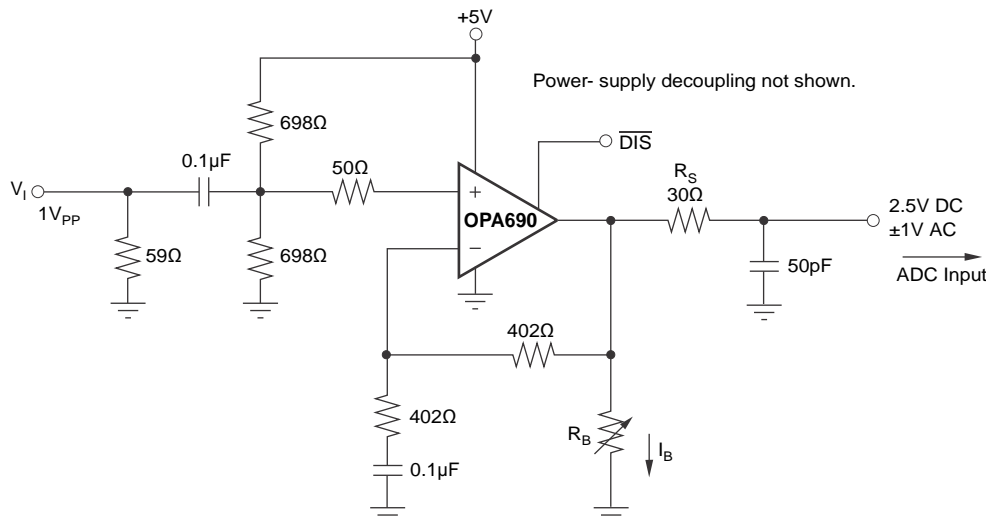

Copyright © 2016, Texas Instruments Incorporated

Figure 45. SFDR vs I_B Test Circuit

9.2.1.1 Design Requirements

Most modern, high performance ADCs (such as the TI ADS8xx and ADS9xx series) operate on a single 5-V (or lower) power supply. It is a considerable challenge for single-supply op amps to deliver a low distortion input signal at the ADC input for signal frequencies exceeding 5 MHz. The high slew rate, exceptional output swing, and high linearity of the OPA690 make it an ideal single-supply ADC driver.

9.2.1.2 Detailed Design Procedure

The *Single-Supply ADC Driver* shows one possible (inverting) interface. Figure 45 shows the test circuit of Figure 37 modified for a capacitive (ADC) load and with an optional output pulldown resistor (R_B).

The OPA690 in the circuit of Figure 45 provides > 200-MHz bandwidth for a 2- V_{PP} output swing. Minimal 3rd-harmonic distortion or two-tone, 3rd-order intermodulation distortion is observed due to the very low crossover distortion in the OPA690 output stage. The limit of output spurious-free dynamic range (SFDR) is set by the 2nd-harmonic distortion. Without R_B , the circuit of Figure 45 measured at 10 MHz shows an SFDR of 57 dBc. This may be improved by pulling additional DC bias current (I_B) out of the output stage through the optional R_B resistor to ground (the output midpoint is at 2.5 V for Figure 45). Adjusting I_B gives the improvement in SFDR shown in Figure 46. SFDR improvement is achieved for I_B values up to 5 mA, with worse performance for higher values.

Typical Applications (continued)

9.2.1.3 Application Curve

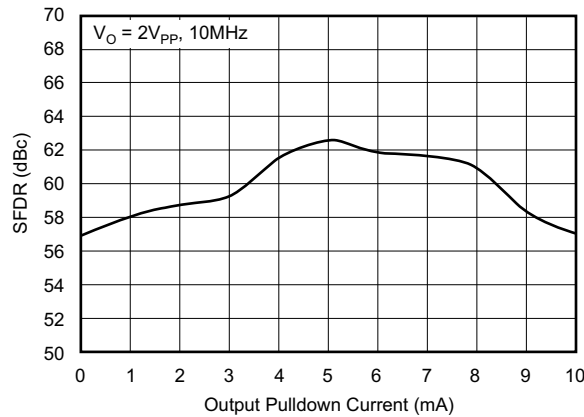
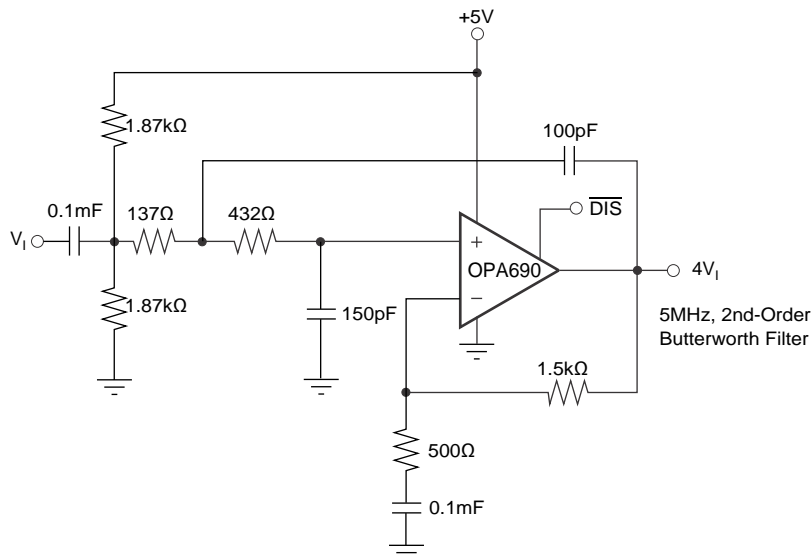

Figure 46. SFDR vs I_B

9.2.2 Single-Supply Active Filters



Copyright © 2016, Texas Instruments Incorporated

Figure 47. Single-Supply, High-Frequency Active Filter

9.2.2.1 Design Requirements

The high bandwidth provided by the OPA690, while operating on a single 5-V supply, lends itself well to high-frequency active filter designs. Again, the key additional requirement is to establish the DC operating point of the signal near the supply midpoint for highest dynamic range. See Figure 47 for an example design of a 5-MHz low-pass Butterworth filter using the Sallen-Key topology.

Both the input signal and the gain setting resistor are AC-coupled using 0.1-μF blocking capacitors (actually giving band-pass response with the low-frequency pole set to 32 kHz for the component values shown). As discussed for Figure 37, this allows the midpoint bias formed by the two 1.87-kΩ resistors to appear at both the input and output pins. The midband signal gain is set to 4 (12 dB) in this case. The capacitor to ground on the noninverting input is intentionally set larger to dominate input parasitic terms. At a gain of 4, the OPA690 on a single supply shows approximately 80-MHz small- and large-signal bandwidth. The resistor values have been slightly adjusted to account for this limited bandwidth in the amplifier stage. Tests of this circuit show a precise 5-MHz, -3-dB point with a maximally flat pass band (above the 32-kHz AC-coupling corner), and a maximum stop band attenuation of 36 dB at the -3-dB bandwidth of 80 MHz of the amplifier.

Typical Applications (continued)

9.2.2.2 Application Curve

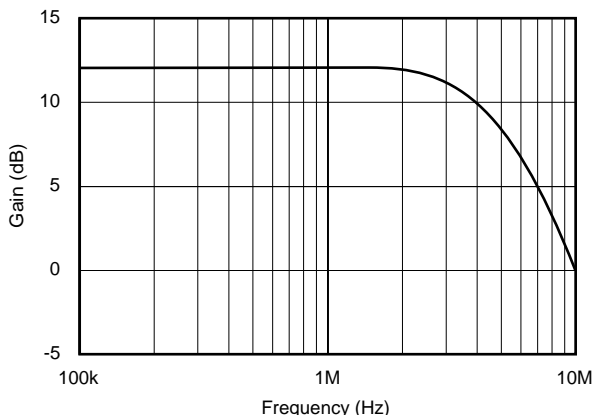
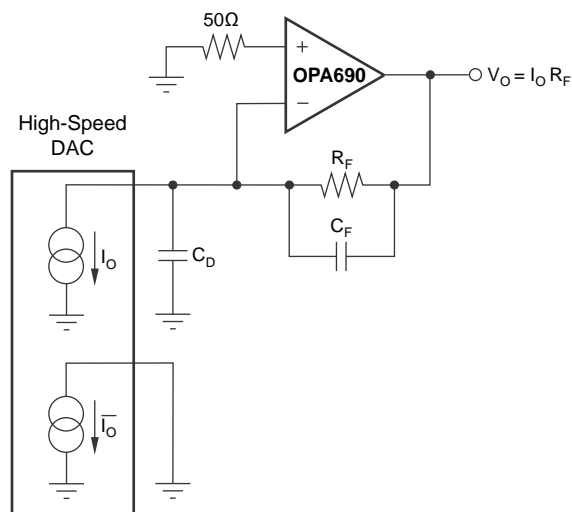

Figure 48. 5-MHz, 2nd-Order Butterworth Filter Response

9.2.3 High-Performance DAC Transimpedance Amplifier



Copyright © 2016, Texas Instruments Incorporated

Figure 49. DAC Transimpedance Amplifier

9.2.3.1 Design Requirements

High-frequency, direct digital synthesis (DDS) Digital-to-Analog Converters (DACs) require a low-distortion output amplifier to retain their SFDR performance into real-world loads. See [Figure 49](#) for a single-ended output drive implementation.

9.2.3.2 Detailed Design Procedure

In this circuit, only one side of the complementary output drive signal is used. [Figure 49](#) shows the signal output current connected into the virtual ground summing junction of the OPA690, which is set up as a transimpedance stage or *I-V converter*. The unused current output of the DAC is connected to ground. If the DAC requires that its outputs terminate to a compliance voltage other than ground for operation, the appropriate voltage level may be applied to the noninverting input of the OPA690. The DC gain for this circuit is equal to R_F . At high frequencies, the DAC output capacitance produces a zero in the noise gain for the OPA690 that may cause peaking in the closed-loop frequency response. C_F is added across R_F to compensate for this noise gain peaking. To achieve a flat transimpedance frequency response, the pole in the feedback network must be set to [Equation 6](#).

Typical Applications (continued)

$$\frac{1}{2\pi R_F C_F} = \sqrt{\frac{\text{GBP}}{4\pi R_F C_D}} \quad (6)$$

Equation 6 gives a closed-loop transimpedance bandwidth, $f_{-3\text{dB}}$, of approximately Equation 7.

$$f_{-3\text{dB}} = \sqrt{\frac{\text{GBP}}{2\pi R_F C_D}}$$

where

- GBP = gain bandwidth product (Hz) for the OPA690 (7)

9.2.4 High-Power Line Driver

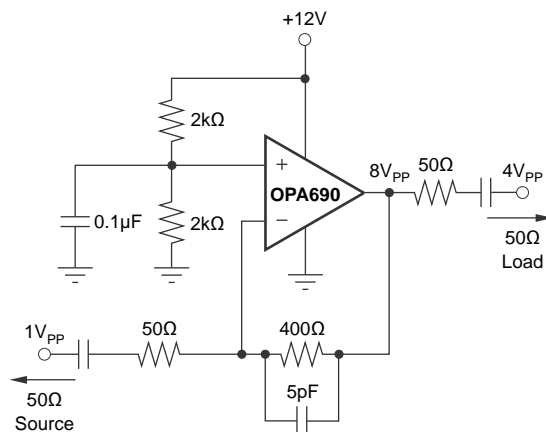

Copyright © 2016, Texas Instruments Incorporated

Figure 50. High-Power Coax Line Driver

9.2.4.1 Design Requirements

The large output swing capability of the OPA690 and its high current capability allow it to drive a 50-Ω line with a peak-to-peak signal up to 4 V_{PP} at the load, or 8 V_{PP} at the output of the amplifier using a single 12-V supply. Figure 50 shows such a circuit set for a gain of 8 to the output or 4 to the load.

The 5-pF capacitor in the feedback loop provides added bandwidth control for the signal path.

10 Power Supply Recommendations

The OPA690 is principally intended to work in a supply range of ± 2.5 V to ± 6 V. Good power-supply bypassing is required. Minimize the distance (< 0.1 inch) from the power-supply pins to high frequency, $0.1\text{-}\mu\text{F}$ decoupling capacitors. Often a larger capacitor ($2.2\ \mu\text{F}$ is typical) is used along with a high-frequency, $0.1\text{-}\mu\text{F}$ supply decoupling capacitor at the device supply pins.

For single-supply operation, only the positive supply has these capacitors. When a split supply is used, use these capacitors for each supply to ground. If necessary, place the larger capacitors somewhat farther from the device and share these capacitors among several devices in the same area of the PCB.

Avoid narrow power and ground traces to minimize inductance between the pins and the decoupling capacitors. An optional supply decoupling capacitor across the two power supplies (for bipolar operation) improves second harmonic distortion performance.

11 Layout

11.1 Layout Guidelines

Achieving optimum performance with a high-frequency amplifier like the OPA690 requires careful attention to board layout parasitics and external component types. Recommendations that optimize performance include:

1. Minimize parasitic capacitance to any AC ground for all of the signal I/O pins. Parasitic capacitance on the output and inverting input pins can cause instability: on the noninverting input, it can react with the source impedance to cause unintentional bandlimiting. To reduce unwanted capacitance, a window around the signal I/O pins must be opened in all of the ground and power planes around those pins. Otherwise, ground and power planes must be unbroken elsewhere on the board.
2. Minimize the distance (< 0.25 ") from the power-supply pins to high-frequency $0.1\text{-}\mu\text{F}$ decoupling capacitors. At the device pins, the ground and power-plane layout must not be in close proximity to the signal I/O pins. Avoid narrow power and ground traces to minimize inductance between the pins and the decoupling capacitors. The power-supply connections must always be decoupled with these capacitors. An optional supply decoupling capacitor ($0.1\text{-}\mu\text{F}$) across the two power supplies (for bipolar operation) improve 2nd-harmonic distortion performance. Larger ($2.2\text{-}\mu\text{F}$ to $6.8\text{-}\mu\text{F}$) decoupling capacitors, effective at lower frequencies, must also be used on the main supply pins. These may be placed somewhat farther from the device and may be shared among several devices in the same area of the PCB.
3. Careful selection and placement of external components preserve the high-frequency performance of the OPA690. Resistors must be a very low reactance type. Surface-mount resistors work best and allow a tighter overall layout. Metal film or carbon composition axially-leaded resistors can also provide good high-frequency performance. Again, keep their leads and PCB traces as short as possible. Never use wirewound type resistors in a high-frequency application. Because the output pin and inverting input pin are the most sensitive to parasitic capacitance, always position the feedback and series output resistor, if any, as close as possible to the output pin. Other network components, such as noninverting input termination resistors, must also be placed close to the package. Where double-side component mounting is allowed, place the feedback resistor directly under the package on the other side of the board between the output and inverting input pins. Even with a low parasitic capacitance shunting the external resistors, excessively high resistor values can create significant time constants that can degrade performance. Good axial metal film or surface-mount resistors have approximately $0.2\ \text{pF}$ in shunt with the resistor. For resistor values $> 1.5\ \text{k}\Omega$, this parasitic capacitance can add a pole or zero below $500\ \text{MHz}$ that can affect circuit operation. Keep resistor values as low as possible consistent with load driving considerations. The $402\text{-}\Omega$ feedback is a good starting point for design. A $25\text{-}\Omega$ feedback resistor, rather than a direct short, is suggested for the unity-gain follower application. This effectively isolates the inverting input capacitance from the output pin that would otherwise cause an additional peaking in the gain of 1 frequency response.
4. Connections to other wideband devices on the board may be made with short, direct traces or through onboard transmission lines. For short connections, consider the trace and the input to the next device as a lumped capacitive load. Relatively wide traces (50 mils or $1.27\ \text{mm}$ to 100 mils or $2.54\ \text{mm}$) must be used, preferably with ground and power planes opened up around them. Estimate the total capacitive load and set R_S from the plot of Recommended R_S vs Capacitive Load ([Figure 15](#) for ± 5 V and [Figure 30](#) for 5 V). Low parasitic capacitive loads ($< 5\ \text{pF}$) may not require an R_S because the OPA690 is nominally compensated to operate with a 2-pF parasitic load. Higher parasitic capacitive loads without an R_S are allowed as the signal gain increases (increasing the unloaded phase margin). If a long trace is required, and the 6-dB signal loss

Layout Guidelines (continued)

intrinsic to a doubly-terminated transmission line is acceptable, implement a matched impedance transmission line using microstrip or stripline techniques (consult an ECL design handbook for microstrip and stripline layout techniques). A 50-Ω environment is normally not necessary on board, and in fact, a higher impedance environment improves distortion as shown in the distortion versus load plots. With a characteristic board trace impedance defined (based on board material and trace dimensions), a matching series resistor into the trace from the output of the OPA690 is used as well as a terminating shunt resistor at the input of the destination device. Remember also that the terminating impedance is the parallel combination of the shunt resistor and the input impedance of the destination device; this total effective impedance must be set to match the trace impedance. The high output voltage and current capability of the OPA690 allows multiple destination devices to be handled as separate transmission lines, each with their own series and shunt terminations. If the 6-dB attenuation of a doubly-terminated transmission line is unacceptable, a long trace can be series-terminated at the source end only. Treat the trace as a capacitive load in this case and set the series resistor value as shown in the plot of Recommended R_S vs Capacitive Load (Figure 15 for ± 5 V and Figure 30 for 5 V). This does not preserve signal integrity as well as a doubly-terminated line. If the input impedance of the destination device is low, there is some signal attenuation due to the voltage divider formed by the series output into the terminating impedance.

5. Socketing a high-speed part like the OPA690 is not recommended. The additional lead length and pin-to-pin capacitance introduced by the socket can create an extremely troublesome parasitic network which can make it almost impossible to achieve a smooth, stable frequency response. Best results are obtained by soldering the OPA690 onto the board.

11.1.1 Input and ESD Protection

The OPA690 is built using a very high-speed complementary bipolar process. The internal junction breakdown voltages are relatively low for these very small geometry devices. These breakdowns are reflected in the *Absolute Maximum Ratings*. All device pins are protected with internal ESD protection diodes to the power supplies, as shown in Figure 51.

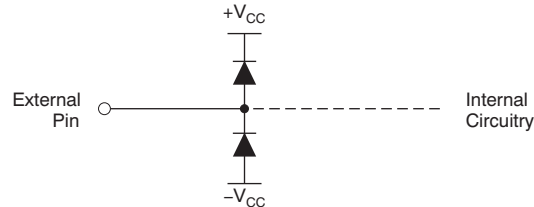

Figure 51. Internal ESD Protection

These diodes provide moderate protection to input overdrive voltages above the supplies as well. The protection diodes can typically support 30-mA continuous current. Where higher currents are possible (for example, in systems with ± 15 -V supply parts driving into the OPA690), current-limiting series resistors must be added into the two inputs. Keep these resistor values as low as possible, because high values degrade both noise performance and frequency response.

11.2 Layout Example

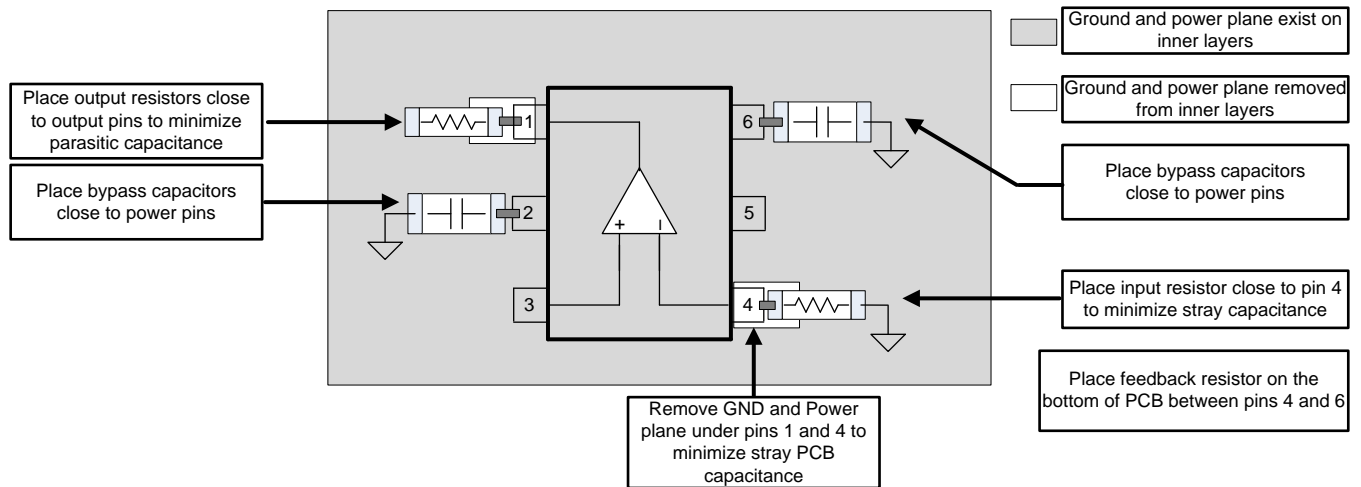

Figure 52. OPA690 Layout

12 Device and Documentation Support

12.1 Device Support

12.1.1 Macromodels and Applications Support

Computer simulation of circuit performance using SPICE is often useful when analyzing the performance of analog circuits and systems. This is particularly true for video and RF amplifier circuits where parasitic capacitance and inductance can have a major effect on circuit performance. A SPICE model for the OPA690 is available through the [OPA690](#) product folder under *Simulation Models*. These models do a good job of predicting small-signal ac and transient performance under a wide variety of operating conditions. They do not do as well in predicting the harmonic distortion or dG/dP characteristics. These models do not attempt to distinguish between the package types in their small-signal ac performance.

12.1.2 Demonstration Fixtures

Two printed-circuit boards (PCBs) are available to assist in the initial evaluation of circuit performance using the OPA690 in its two package options. Both of these are offered free of charge as unpopulated PCBs, delivered with a user's guide. The summary information for these fixtures is shown in [Table 1](#).

Table 1. Demonstration Fixtures by Package

PRODUCT	PACKAGE	ORDERING NUMBER	LITERATURE NUMBER
OPA690ID	8-pin SOIC	DEM-OPA-SO-1A	SBOU009
OPA690IDBV	6-pin SOT-23	DEM-OPA-SOT-1A	SBOU010

The demonstration fixtures can be requested at the Texas Instruments web site (www.ti.com) through the [OPA690](#) product folder.

12.2 Receiving Notification of Documentation Updates

To receive notification of documentation updates, navigate to the device product folder on ti.com. In the upper right corner, click on *Alert me* to register and receive a weekly digest of any product information that has changed. For change details, review the revision history included in any revised document.

12.3 Community Resources

The following links connect to TI community resources. Linked contents are provided "AS IS" by the respective contributors. They do not constitute TI specifications and do not necessarily reflect TI's views; see TI's [Terms of Use](#).

TI E2E™ Online Community *TI's Engineer-to-Engineer (E2E) Community*. Created to foster collaboration among engineers. At e2e.ti.com, you can ask questions, share knowledge, explore ideas and help solve problems with fellow engineers.

Design Support *TI's Design Support* Quickly find helpful E2E forums along with design support tools and contact information for technical support.

12.4 Trademarks

E2E is a trademark of Texas Instruments.
All other trademarks are the property of their respective owners.

12.5 Electrostatic Discharge Caution



These devices have limited built-in ESD protection. The leads should be shorted together or the device placed in conductive foam during storage or handling to prevent electrostatic damage to the MOS gates.

12.6 Glossary

[SLYZ022](#) — *TI Glossary*.

This glossary lists and explains terms, acronyms, and definitions.

13 Mechanical, Packaging, and Orderable Information

The following pages include mechanical, packaging, and orderable information. This information is the most current data available for the designated devices. This data is subject to change without notice and revision of this document. For browser-based versions of this data sheet, refer to the left-hand navigation.

PACKAGING INFORMATION

Orderable Device	Status (1)	Package Type	Package Drawing	Pins	Package Qty	Eco Plan (2)	Lead/Ball Finish (6)	MSL Peak Temp (3)	Op Temp (°C)	Device Marking (4/5)	Samples
OPA690ID	ACTIVE	SOIC	D	8	75	Green (RoHS & no Sb/Br)	CU NIPDAU	Level-2-260C-1 YEAR	-40 to 85	OPA 690	Samples
OPA690IDBVR	ACTIVE	SOT-23	DBV	6	3000	Green (RoHS & no Sb/Br)	CU NIPDAU	Level-2-260C-1 YEAR	-40 to 85	OAEI	Samples
OPA690IDBVRG4	ACTIVE	SOT-23	DBV	6	3000	Green (RoHS & no Sb/Br)	CU NIPDAU	Level-2-260C-1 YEAR	-40 to 85	OAEI	Samples
OPA690IDBVT	ACTIVE	SOT-23	DBV	6	250	Green (RoHS & no Sb/Br)	CU NIPDAU	Level-2-260C-1 YEAR	-40 to 85	OAEI	Samples
OPA690IDBVTG4	ACTIVE	SOT-23	DBV	6	250	Green (RoHS & no Sb/Br)	CU NIPDAU	Level-2-260C-1 YEAR	-40 to 85	OAEI	Samples
OPA690IDG4	ACTIVE	SOIC	D	8	75	Green (RoHS & no Sb/Br)	CU NIPDAU	Level-2-260C-1 YEAR	-40 to 85	OPA 690	Samples
OPA690IDR	ACTIVE	SOIC	D	8	2500	Green (RoHS & no Sb/Br)	CU NIPDAU	Level-2-260C-1 YEAR	-40 to 85	OPA 690	Samples
OPA690IDRG4	ACTIVE	SOIC	D	8	2500	Green (RoHS & no Sb/Br)	CU NIPDAU	Level-2-260C-1 YEAR	-40 to 85	OPA 690	Samples

(1) The marketing status values are defined as follows:

ACTIVE: Product device recommended for new designs.

LIFEBUY: TI has announced that the device will be discontinued, and a lifetime-buy period is in effect.

NRND: Not recommended for new designs. Device is in production to support existing customers, but TI does not recommend using this part in a new design.

PREVIEW: Device has been announced but is not in production. Samples may or may not be available.

OBSOLETE: TI has discontinued the production of the device.

(2) Eco Plan - The planned eco-friendly classification: Pb-Free (RoHS), Pb-Free (RoHS Exempt), or Green (RoHS & no Sb/Br) - please check <http://www.ti.com/productcontent> for the latest availability information and additional product content details.

TBD: The Pb-Free/Green conversion plan has not been defined.

Pb-Free (RoHS): TI's terms "Lead-Free" or "Pb-Free" mean semiconductor products that are compatible with the current RoHS requirements for all 6 substances, including the requirement that lead not exceed 0.1% by weight in homogeneous materials. Where designed to be soldered at high temperatures, TI Pb-Free products are suitable for use in specified lead-free processes.

Pb-Free (RoHS Exempt): This component has a RoHS exemption for either 1) lead-based flip-chip solder bumps used between the die and package, or 2) lead-based die adhesive used between the die and leadframe. The component is otherwise considered Pb-Free (RoHS compatible) as defined above.

Green (RoHS & no Sb/Br): TI defines "Green" to mean Pb-Free (RoHS compatible), and free of Bromine (Br) and Antimony (Sb) based flame retardants (Br or Sb do not exceed 0.1% by weight in homogeneous material)

(3) MSL, Peak Temp. - The Moisture Sensitivity Level rating according to the JEDEC industry standard classifications, and peak solder temperature.

(4) There may be additional marking, which relates to the logo, the lot trace code information, or the environmental category on the device.

(5) Multiple Device Markings will be inside parentheses. Only one Device Marking contained in parentheses and separated by a "~" will appear on a device. If a line is indented then it is a continuation of the previous line and the two combined represent the entire Device Marking for that device.

(6) Lead/Ball Finish - Orderable Devices may have multiple material finish options. Finish options are separated by a vertical ruled line. Lead/Ball Finish values may wrap to two lines if the finish value exceeds the maximum column width.

Important Information and Disclaimer:The information provided on this page represents TI's knowledge and belief as of the date that it is provided. TI bases its knowledge and belief on information provided by third parties, and makes no representation or warranty as to the accuracy of such information. Efforts are underway to better integrate information from third parties. TI has taken and continues to take reasonable steps to provide representative and accurate information but may not have conducted destructive testing or chemical analysis on incoming materials and chemicals. TI and TI suppliers consider certain information to be proprietary, and thus CAS numbers and other limited information may not be available for release.

In no event shall TI's liability arising out of such information exceed the total purchase price of the TI part(s) at issue in this document sold by TI to Customer on an annual basis.

TAPE AND REEL INFORMATION



QUADRANT ASSIGNMENTS FOR PIN 1 ORIENTATION IN TAPE



*All dimensions are nominal

Device	Package Type	Package Drawing	Pins	SPQ	Reel Diameter (mm)	Reel Width W1 (mm)	A0 (mm)	B0 (mm)	K0 (mm)	P1 (mm)	W (mm)	Pin1 Quadrant
OPA690IDR	SOIC	D	8	2500	330.0	12.4	6.4	5.2	2.1	8.0	12.0	Q1

TAPE AND REEL BOX DIMENSIONS



*All dimensions are nominal

Device	Package Type	Package Drawing	Pins	SPQ	Length (mm)	Width (mm)	Height (mm)
OPA690IDR	SOIC	D	8	2500	367.0	367.0	35.0

DBV0006A



PACKAGE OUTLINE

SOT-23 - 1.45 mm max height

SMALL OUTLINE TRANSISTOR

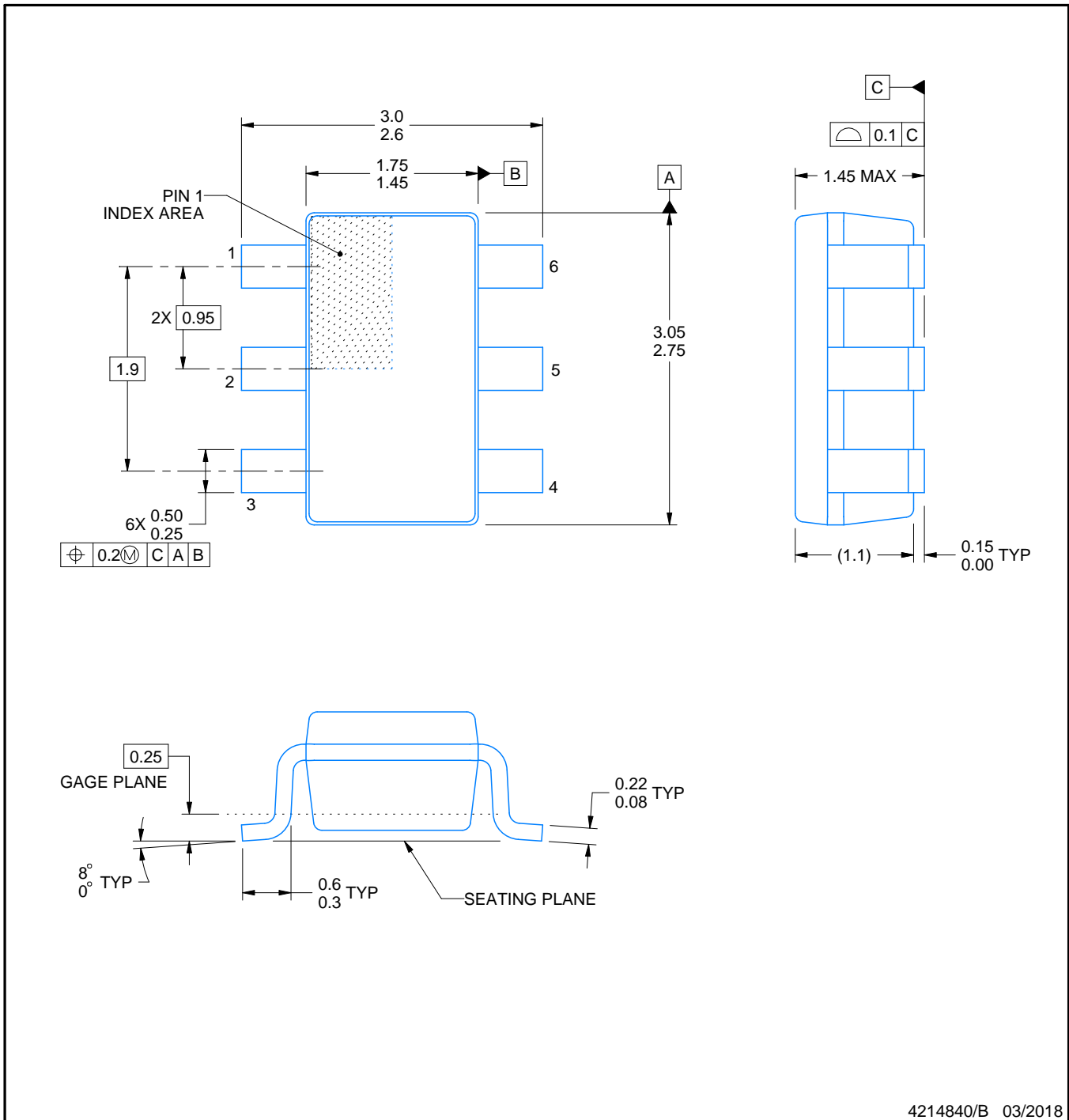

4214840/B 03/2018

NOTES:

1. All linear dimensions are in millimeters. Any dimensions in parenthesis are for reference only. Dimensioning and tolerancing per ASME Y14.5M.
2. This drawing is subject to change without notice.
3. Body dimensions do not include mold flash or protrusion. Mold flash and protrusion shall not exceed 0.15 per side.
4. Leads 1,2,3 may be wider than leads 4,5,6 for package orientation.
5. Reference JEDEC MO-178.

EXAMPLE BOARD LAYOUT

DBV0006A

SOT-23 - 1.45 mm max height

SMALL OUTLINE TRANSISTOR

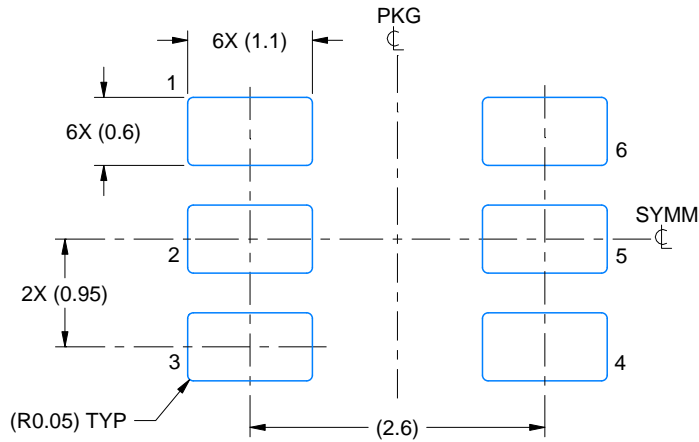

LAND PATTERN EXAMPLE
EXPOSED METAL SHOWN
SCALE:15X

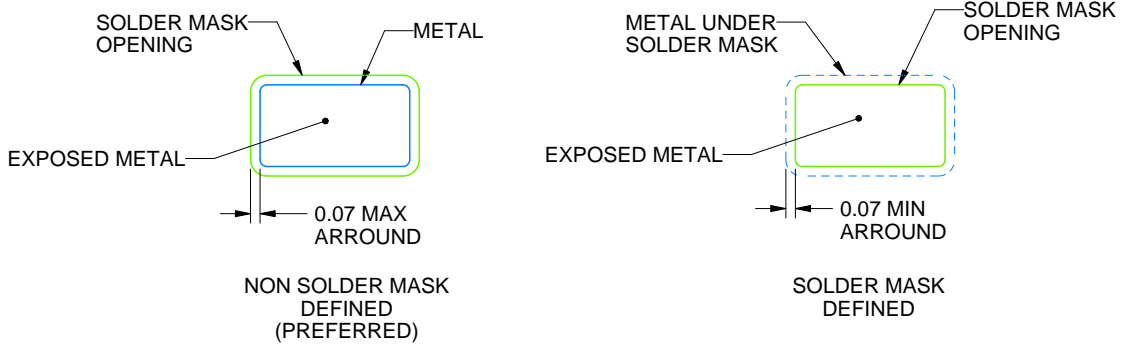

SOLDER MASK DETAILS

4214840/B 03/2018

NOTES: (continued)

6. Publication IPC-7351 may have alternate designs.

7. Solder mask tolerances between and around signal pads can vary based on board fabrication site.

EXAMPLE STENCIL DESIGN

DBV0006A

SOT-23 - 1.45 mm max height

SMALL OUTLINE TRANSISTOR

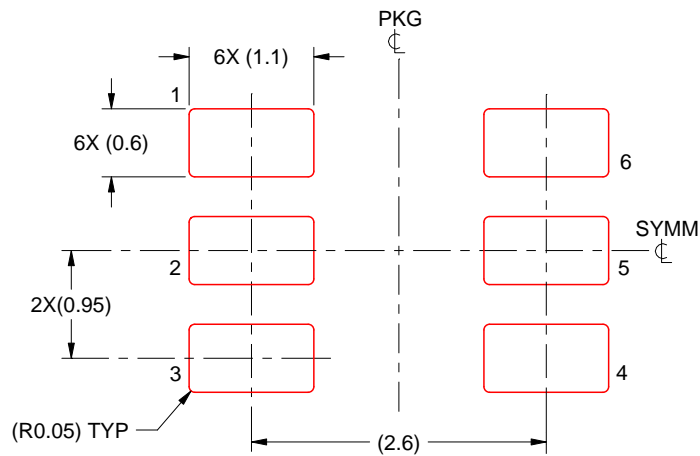

SOLDER PASTE EXAMPLE
BASED ON 0.125 mm THICK STENCIL
SCALE:15X

4214840/B 03/2018

NOTES: (continued)

8. Laser cutting apertures with trapezoidal walls and rounded corners may offer better paste release. IPC-7525 may have alternate design recommendations.
9. Board assembly site may have different recommendations for stencil design.



D0008A

PACKAGE OUTLINE

SOIC - 1.75 mm max height

SMALL OUTLINE INTEGRATED CIRCUIT



4214825/C 02/2019

NOTES:

1. Linear dimensions are in inches [millimeters]. Dimensions in parenthesis are for reference only. Controlling dimensions are in inches. Dimensioning and tolerancing per ASME Y14.5M.
2. This drawing is subject to change without notice.
3. This dimension does not include mold flash, protrusions, or gate burrs. Mold flash, protrusions, or gate burrs shall not exceed $.006$ [0.15] per side.
4. This dimension does not include interlead flash.
5. Reference JEDEC registration MS-012, variation AA.

EXAMPLE BOARD LAYOUT

D0008A

SOIC - 1.75 mm max height

SMALL OUTLINE INTEGRATED CIRCUIT



LAND PATTERN EXAMPLE
 EXPOSED METAL SHOWN
 SCALE:8X



SOLDER MASK DETAILS

4214825/C 02/2019

NOTES: (continued)

- 6. Publication IPC-7351 may have alternate designs.
- 7. Solder mask tolerances between and around signal pads can vary based on board fabrication site.

EXAMPLE STENCIL DESIGN

D0008A

SOIC - 1.75 mm max height

SMALL OUTLINE INTEGRATED CIRCUIT



SOLDER PASTE EXAMPLE
BASED ON .005 INCH [0.125 MM] THICK STENCIL
SCALE:8X

4214825/C 02/2019

NOTES: (continued)

8. Laser cutting apertures with trapezoidal walls and rounded corners may offer better paste release. IPC-7525 may have alternate design recommendations.
9. Board assembly site may have different recommendations for stencil design.

IMPORTANT NOTICE AND DISCLAIMER

TI PROVIDES TECHNICAL AND RELIABILITY DATA (INCLUDING DATASHEETS), DESIGN RESOURCES (INCLUDING REFERENCE DESIGNS), APPLICATION OR OTHER DESIGN ADVICE, WEB TOOLS, SAFETY INFORMATION, AND OTHER RESOURCES "AS IS" AND WITH ALL FAULTS, AND DISCLAIMS ALL WARRANTIES, EXPRESS AND IMPLIED, INCLUDING WITHOUT LIMITATION ANY IMPLIED WARRANTIES OF MERCHANTABILITY, FITNESS FOR A PARTICULAR PURPOSE OR NON-INFRINGEMENT OF THIRD PARTY INTELLECTUAL PROPERTY RIGHTS.

These resources are intended for skilled developers designing with TI products. You are solely responsible for (1) selecting the appropriate TI products for your application, (2) designing, validating and testing your application, and (3) ensuring your application meets applicable standards, and any other safety, security, or other requirements. These resources are subject to change without notice. TI grants you permission to use these resources only for development of an application that uses the TI products described in the resource. Other reproduction and display of these resources is prohibited. No license is granted to any other TI intellectual property right or to any third party intellectual property right. TI disclaims responsibility for, and you will fully indemnify TI and its representatives against, any claims, damages, costs, losses, and liabilities arising out of your use of these resources.

TI's products are provided subject to TI's Terms of Sale (www.ti.com/legal/termsofsale.html) or other applicable terms available either on ti.com or provided in conjunction with such TI products. TI's provision of these resources does not expand or otherwise alter TI's applicable warranties or warranty disclaimers for TI products.

Mailing Address: Texas Instruments, Post Office Box 655303, Dallas, Texas 75265
Copyright © 2019, Texas Instruments Incorporated

Looking for pricing, stock, or lifecycle information?

Click below to explore more details on WIN SOURCE:

 [View OPA690IDBVRG4 on WIN SOURCE](#)

 [Texas Instruments](#) Information

Optimize Your Supply Chain with WIN SOURCE Solutions

-  Global Sourcing Solution
-  Obsolete Management
-  Cost Control Management
-  Shortage Management
-  Alternative Solution
-  Excess Inventory Management