

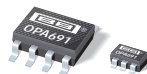

THE DATASHEET OF OPA691IDBVT





Wideband, Current Feedback OPERATIONAL AMPLIFIER With Disable

FEATURES

- FLEXIBLE SUPPLY RANGE:
 - +5V to +12V Single-Supply
 - ±2.5V to ±6V Dual-Supply
- UNITY-GAIN STABLE: 280MHz (G = 1)
- HIGH OUTPUT CURRENT: 190mA
- OUTPUT VOLTAGE SWING: ±4.0V
- HIGH SLEW RATE: 2100V/μs
- LOW dG/dφ: 0.07%/0.02°
- LOW SUPPLY CURRENT: 5.1mA
- LOW DISABLED CURRENT: 150μA
- WIDEBAND +5V OPERATION: 190MHz (G = +2)

DESCRIPTION

The OPA691 sets a new level of performance for broadband current feedback op amps. Operating on a very low 5.1mA supply current, the OPA691 offers a slew rate and output power normally associated with a much higher supply current. A new output stage architecture delivers a high output current with minimal voltage headroom and crossover distortion. This gives exceptional single-supply operation. Using a single +5V supply, the OPA691 can deliver a 1V to 4V output swing with over 150mA drive current and 190MHz bandwidth. This combination of features makes the OPA691 an ideal RGB line driver or single-supply Analog-to-Digital Converter (ADC) input driver.

The OPA691's low 5.1mA supply current is precisely trimmed at 25°C. This trim, along with low drift over-temperature,

APPLICATIONS

- xDSL LINE DRIVER
- BROADBAND VIDEO BUFFERS
- HIGH-SPEED IMAGING CHANNELS
- PORTABLE INSTRUMENTS
- ADC BUFFERS
- ACTIVE FILTERS
- WIDEBAND INVERTING SUMMING
- HIGH SFDR IF AMPLIFIER

ensures lower maximum supply current than competing products. System power may be further reduced by using the optional disable control pin. Leaving this disable pin open, or holding it HIGH, gives normal operation. If pulled LOW, the OPA691 supply current drops to less than 150μA while the output goes into a high impedance state. This feature may be used for power savings.

OPA691 RELATED PRODUCTS

	SINGLES	DUALS	TRIPLES
Voltage Feedback	OPA690	OPA2690	OPA3690
Current Feedback	OPA681	OPA2691	OPA3691
Fixed Gain	OPA692		OPA3692

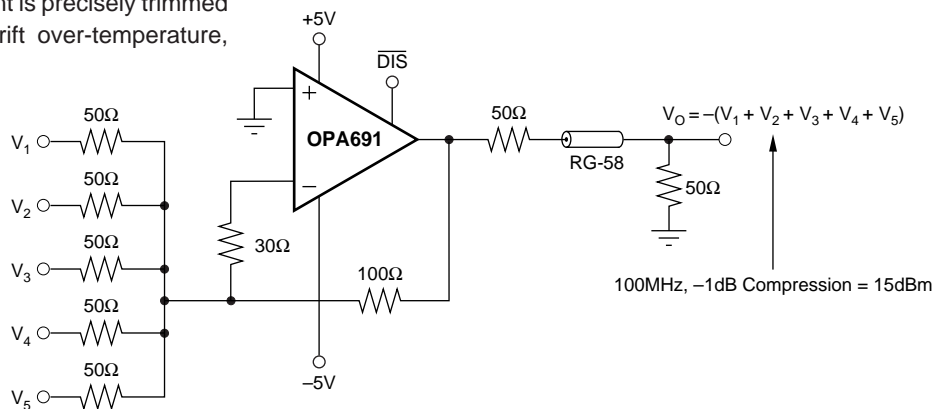

200MHz RF Summing Amplifier



Please be aware that an important notice concerning availability, standard warranty, and use in critical applications of Texas Instruments semiconductor products and disclaimers thereto appears at the end of this data sheet.

All trademarks are the property of their respective owners.

PRODUCTION DATA information is current as of publication date. Products conform to specifications per the terms of Texas Instruments standard warranty. Production processing does not necessarily include testing of all parameters.

ABSOLUTE MAXIMUM RATINGS⁽¹⁾

Power Supply	±6.5VDC
Internal Power Dissipation ⁽²⁾	See Thermal Information
Differential Input Voltage	±1.2V
Input Voltage Range	±V _S
Storage Temperature Range: ID, IDBV	-65°C to +125°C
Lead Temperature (soldering, 10s)	+300°C
Junction Temperature (T _J)	+175°C
ESD Performance:	
HBM	2000V
CDM	1500V

NOTES: (1) Stresses above these ratings may cause permanent damage. Exposure to absolute maximum conditions for extended periods may degrade device reliability. (2) Packages must be derated based on specified θ_{JA} . Maximum T_J must be observed.



ELECTROSTATIC DISCHARGE SENSITIVITY

This integrated circuit can be damaged by ESD. Texas Instruments recommends that all integrated circuits be handled with appropriate precautions. Failure to observe proper handling and installation procedures can cause damage.

ESD damage can range from subtle performance degradation to complete device failure. Precision integrated circuits may be more susceptible to damage because very small parametric changes could cause the device not to meet its published specifications.

PACKAGE/ORDERING INFORMATION⁽¹⁾

PRODUCT	PACKAGE-LEAD	PACKAGE DESIGNATOR	SPECIFIED TEMPERATURE RANGE	PACKAGE MARKING	ORDERING NUMBER	TRANSPORT MEDIA, QUANTITY
OPA691ID	SO-8	D	-40°C to +85°C	OPA691	OPA691ID	Rails, 100
"	"	"	"	"	OPA691IDR	Tape and Reel, 2500
OPA691IDBV	SOT23-6	DBV	-40°C to +85°C	OAFI	OPA691IDBVT	Tape and Reel, 250
"	"	"	"	"	OPA691IDBVR	Tape and Reel, 3000

NOTE: (1) For the most current package and ordering information, see the Package Option Addendum located at the end of this document, or see the TI website at www.ti.com.

PIN CONFIGURATION

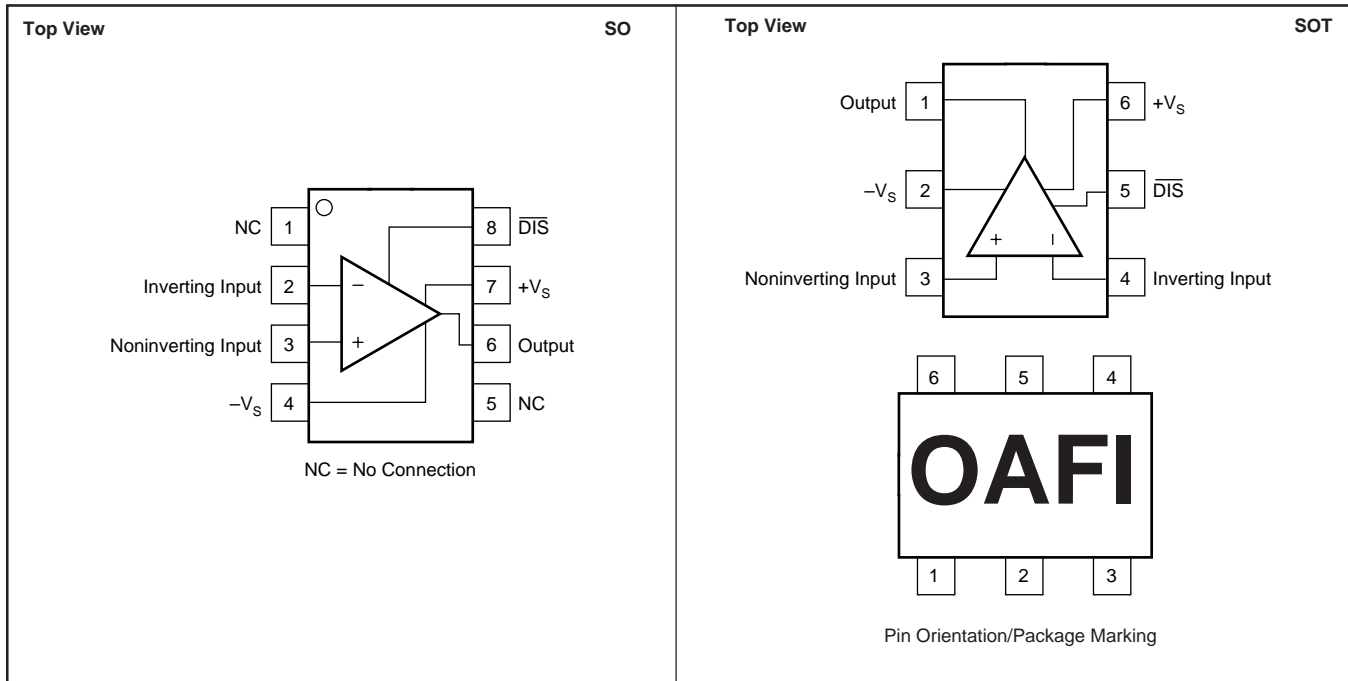

ELECTRICAL CHARACTERISTICS: $V_S = \pm 5V$

Boldface limits are tested at +25°C.

$R_F = 402\Omega$, $R_L = 100\Omega$, and $G = +2$, (see Figure 1 for AC performance only), unless otherwise noted.

PARAMETER	CONDITIONS	OPA691ID, IDBV					TEST LEVEL ⁽³⁾	
		TYP	MIN/MAX OVER-TEMPERATURE					
		+25°C	+25°C ⁽¹⁾	0°C to 70°C ⁽²⁾	-40°C to +85°C ⁽²⁾	UNITS		MIN/MAX
AC PERFORMANCE (see Figure 1)								
Small-Signal Bandwidth ($V_O = 0.5V_{PP}$)	$G = +1$, $R_F = 453\Omega$	280				MHz	typ	C
	$G = +2$, $R_F = 402\Omega$	225	200	190	180	MHz	min	B
	$G = +5$, $R_F = 261\Omega$	210				MHz	typ	C
	$G = +10$, $R_F = 180\Omega$	200				MHz	typ	C
Bandwidth for 0.1dB Gain Flatness	$G = +2$, $V_O = 0.5V_{PP}$	90	40	35	20	MHz	min	B
Peaking at a Gain of +1	$R_F = 453$, $V_O = 0.5V_{PP}$	0.2	1	1.5	2	dB	max	B
Large-Signal Bandwidth	$G = +2$, $V_O = 5V_{PP}$	200				MHz	typ	C
Slew Rate	$G = +2$, 4V Step	2100	1400	1375	1350	V/ μ s	min	B
Rise-and-Fall Time	$G = +2$, $V_O = 0.5V$ Step	1.6				ns	typ	C
	$G = +2$, 5V Step	1.9				ns	typ	C
Settling Time to 0.02%	$G = +2$, $V_O = 2V$ Step	12				ns	typ	C
0.1%	$G = +2$, $V_O = 2V$ Step	8				ns	typ	C
Harmonic Distortion	$G = +2$, $f = 5MHz$, $V_O = 2V_{PP}$							
2nd-Harmonic	$R_L = 100\Omega$	-70	-63	-60	-58	dBc	max	B
	$R_L \geq 500\Omega$	-79	-70	-67	-65	dBc	max	B
3rd-Harmonic	$R_L = 100\Omega$	-74	-72	-70	-68	dBc	max	B
	$R_L \geq 500\Omega$	-93	-87	-82	-78	dBc	max	B
Input Voltage Noise	$f > 1MHz$	1.7	2.5	2.9	3.1	nV/ \sqrt{Hz}	max	B
Noninverting Input Current Noise	$f > 1MHz$	12	14	15	15	pA/ \sqrt{Hz}	max	B
Inverting Input Current Noise	$f > 1MHz$	15	17	18	19	pA/ \sqrt{Hz}	max	B
Differential Gain	$G = +2$, NTSC, $V_O = 1.4V_p$, $R_L = 150\Omega$	0.07				%	typ	C
	$R_L = 37.5\Omega$	0.17				%	typ	C
Differential Phase	$G = +2$, NTSC, $V_O = 1.4V_p$, $R_L = 150\Omega$	0.02				deg	typ	C
	$R_L = 37.5\Omega$	0.07				deg	typ	C
DC PERFORMANCE⁽⁴⁾								
Open-Loop Transimpedance Gain (Z_{OL})	$V_O = 0V$, $R_L = 100\Omega$	225	125	110	100	k Ω	min	A
Input Offset Voltage	$V_{CM} = 0V$	± 0.5	± 2.5	± 3.2	± 3.9	mV	max	A
Average Offset Voltage Drift	$V_{CM} = 0V$			± 12	± 20	$\mu V/^\circ C$	max	B
Noninverting Input Bias Current	$V_{CM} = 0V$	+15	+35	+43	+45	μA	max	A
Average Noninverting Input Bias Current Drift	$V_{CM} = 0V$			-300	-300	nA/ $^\circ C$	max	B
Inverting Input Bias Current	$V_{CM} = 0V$	± 5	± 25	± 30	± 40	μA	max	A
Average Inverting Input Bias Current Drift	$V_{CM} = 0V$			± 90	± 200	nA/ $^\circ C$	max	B
INPUT								
Common-Mode Input Range ⁽⁵⁾		± 3.5	± 3.4	± 3.3	± 3.2	V	min	A
Common-Mode Rejection	$V_{CM} = 0V$	56	52	51	50	dB	min	A
Noninverting Input Impedance		100 2				k Ω pF	typ	C
Inverting Input Resistance (R_I)	Open-Loop	35				Ω	typ	C
OUTPUT								
Voltage Output Swing	No Load	± 4.0	± 3.8	± 3.7	± 3.6	V	min	A
	100 Ω Load	± 3.9	± 3.7	± 3.6	± 3.3	V	min	A
Current Output, Sourcing	$V_O = 0$	+190	+160	+140	+100	mA	min	A
Current Output, Sinking	$V_O = 0$	-190	-160	-140	-100	mA	min	A
Short-Circuit Current	$V_O = 0$	± 250				mA	typ	C
Closed-Loop Output Impedance	$G = +2$, $f = 100kHz$	0.03				Ω	typ	C
DISABLE (Disabled LOW)								
Power-Down Supply Current ($+V_S$)	$V_{DIS} = 0$	-150	-300	-350	-400	μA	max	A
Disable Time	$V_{IN} = 1V$	400				ns	typ	C
Enable Time	$V_{IN} = 1V$	25				ns	typ	C
Off Isolation	$G = +2$, 5MHz	70				dB	typ	C
Output Capacitance in Disable		4				pF	typ	C
Turn On Glitch	$G = +2$, $R_L = 150\Omega$, $V_{IN} = 0$	± 50				mV	typ	C
Turn Off Glitch	$G = +2$, $R_L = 150\Omega$, $V_{IN} = 0$	± 20				mV	typ	C
Enable Voltage		3.3	3.5	3.6	3.7	V	min	A
Disable Voltage		1.8	1.7	1.6	1.5	V	min	A
Control Pin Input Bias Current (\overline{DIS})	$V_{DIS} = 0$	75	130	150	160	μA	max	A
POWER SUPPLY								
Specified Operating Voltage		± 5				V	typ	C
Maximum Operating Voltage Range			± 6	± 6	± 6	V	max	A
Minimum Operating Voltage Range		± 2				V	min	C
Max Quiescent Current	$V_S = \pm 5V$	5.1	5.3	5.5	5.7	mA	max	A
Min Quiescent Current	$V_S = \pm 5V$	5.1	4.9	4.7	4.5	mA	min	A
Power-Supply Rejection Ratio (-PSRR)	Input Referred	58	52	50	49	dB	min	A
TEMPERATURE RANGE								
Specification: D, DBV		-40 to +85				$^\circ C$	typ	C
Thermal Resistance, θ_{JA}	Junction-to-Ambient					$^\circ C/W$	typ	C
D SO-8		125				$^\circ C/W$	typ	C
DBV SOT23-6		150				$^\circ C/W$	typ	C

NOTES: (1) Junction temperature = ambient for 25°C specifications. (2) Junction temperature = ambient at low temperature limit; junction temperature = ambient +10°C at high temperature limit for over-temperature specifications. (3) Test levels: (A) 100% tested at 25°C. Over-temperature limits by characterization and simulation. (B) Limits set by characterization and simulation. (C) Typical value only for information. (4) Current is considered positive out-of-node. V_{CM} is the input common-mode voltage. (5) Tested < 3dB below minimum specified CMRR at \pm CMIR limits.

ELECTRICAL CHARACTERISTICS: $V_S = +5V$

Bolace limits are tested at $+25^\circ C$.

$R_F = 453\Omega$, $R_L = 100\Omega$ to $V_S/2$, and $G = +2$, (see Figure 2 for AC performance only), unless otherwise noted.

PARAMETER	CONDITIONS	OPA691ID, IDBV						TEST LEVEL ⁽³⁾
		TYP	MIN/MAX OVER-TEMPERATURE					
		+25°C	+25°C ⁽¹⁾	0°C to 70°C ⁽²⁾	-40°C to +85°C ⁽²⁾	UNITS	MIN/MAX	
AC PERFORMANCE (see Figure 2)								
Small-Signal Bandwidth ($V_O = 0.5V_{PP}$)	$G = +1$, $R_F = 499\Omega$	210				MHz	typ	C
	$G = +2$, $R_F = 453\Omega$	190	168	160	140	MHz	min	B
	$G = +5$, $R_F = 340\Omega$	180				MHz	typ	C
	$G = +10$, $R_F = 180\Omega$	155				MHz	typ	C
Bandwidth for 0.1dB Gain Flatness	$G = +2$, $V_O < 0.5V_{PP}$	90	40	30	25	MHz	min	B
Peaking at a Gain of +1	$R_F = 649\Omega$, $V_O < 0.5V_{PP}$	0.2	1	2.5	3.0	dB	max	B
Large-Signal Bandwidth	$G = +2$, $V_O = 2V_{PP}$	210				MHz	typ	C
Slew Rate	$G = +2$, 2V Step	850	600	575	550	V/ μ s	min	B
Rise-and-Fall Time	$G = +2$, $V_O = 0.5V$ Step	2.0				ns	typ	C
	$G = +2$, $V_O = 2V$ Step	2.3				ns	typ	C
Settling Time to 0.02%	$G = +2$, $V_O = 2V$ Step	14				ns	typ	C
0.1%	$G = +2$, $V_O = 2V$ Step	10				ns	typ	C
Harmonic Distortion								
2nd-Harmonic	$G = +2$, $f = 5MHz$, $V_O = 2V_{PP}$							
	$R_L = 100\Omega$ to $V_S/2$	-66	-58	-57	-56	dBc	max	B
	$R_L \geq 500\Omega$ to $V_S/2$	-73	-65	-63	-62	dBc	max	B
3rd-Harmonic	$R_L = 100\Omega$ to $V_S/2$	-71	-68	-67	-65	dBc	max	B
	$R_L \geq 500\Omega$ to $V_S/2$	-77	-72	-70	-69	dBc	max	B
Input Voltage Noise	$f > 1MHz$	1.7	2.5	2.9	3.1	nV/ \sqrt{Hz}	typ	B
Noninverting Input Current Noise	$f > 1MHz$	12	14	15	15	pA/ \sqrt{Hz}	typ	B
Inverting Input Current Noise	$f > 1MHz$	15	17	18	19	pA/ \sqrt{Hz}	typ	B
DC PERFORMANCE⁽⁴⁾								
Open-Loop Transimpedance Gain (Z_{OL})	$V_O = V_S/2$, $R_L = 100\Omega$ to $V_S/2$	200	100	90	80	k Ω	min	A
Input Offset Voltage	$V_{CM} = 2.5V$	± 0.5	± 3	± 3.6	± 4.3	mV	max	A
Average Offset Voltage Drift	$V_{CM} = 2.5V$			± 12	± 20	$\mu V/^\circ C$	max	B
Noninverting Input Bias Current	$V_{CM} = 2.5V$	+20	+40	+46	+56	μA	max	A
Average Noninverting Input Bias Current Drift	$V_{CM} = 2.5V$			-250	-250	nA/ $^\circ C$	max	B
Inverting Input Bias Current	$V_{CM} = 2.5V$	± 5	± 20	± 25	± 35	μA	max	A
Average Inverting Input Bias Current Drift	$V_{CM} = 2.5V$			± 112	± 250	nA/ $^\circ C$	max	B
INPUT								
Least Positive Input Voltage ⁽⁵⁾		1.5	1.6	1.7	1.8	V	max	A
Most Positive Input Voltage ⁽⁵⁾		3.5	3.4	3.3	3.2	V	min	A
Common-Mode Rejection Ratio (CMRR)	$V_{CM} = V_S/2$	54	50	49	48	dB	min	A
Noninverting Input Impedance		100 2				k Ω pF	typ	C
Inverting Input Resistance (R_I)	Open-Loop	38				Ω	typ	C
OUTPUT								
Most Positive Output Voltage	No Load	4	3.8	3.7	3.5	V	min	A
	$R_L = 100\Omega$ to $V_S/2$	3.9	3.7	3.6	3.4	V	min	A
Least Positive Output Voltage	No Load	1	1.2	1.3	1.5	V	max	A
	$R_L = 100\Omega$ to $V_S/2$	1.1	1.3	1.4	1.6	V	max	A
Current Output, Sourcing	$V_O = V_S/2$	+160	+120	+100	+80	mA	min	A
Current Output, Sinking	$V_O = V_S/2$	-160	-120	-100	-80	mA	min	A
Short-Circuit Current	$V_O = V_S/2$	250				mA	typ	C
Closed-Loop Output Impedance	$G = +2$, $f = 100kHz$	0.03				Ω	typ	C
DISABLE (Disabled LOW)								
Power-Down Supply Current (+ V_S)	$V_{DIS} = 0$	-150	-300	-350	-400	μA	max	A
Off Isolation	$G = +2$, 5MHz	65				dB	typ	C
Output Capacitance in Disable		4				pF	typ	C
Turn On Glitch	$G = +2$, $R_L = 150\Omega$, $V_{IN} = V_S/2$	± 50				mV	typ	C
Turn Off Glitch	$G = +2$, $R_L = 150\Omega$, $V_{IN} = V_S/2$	± 20				mV	typ	C
Enable Voltage		3.3	3.5	3.6	3.7	V	min	A
Disable Voltage		1.8	1.7	1.6	1.5	V	max	A
Control Pin Input Bias Current (\overline{DIS})	$V_{DIS} = 0$	75	130	150	160	μA	typ	C
POWER SUPPLY								
Specified Single-Supply Operating Voltage		5				V	typ	C
Max Single-Supply Operating Voltage			12	12	12	V	max	A
Min Single-Supply Operating Voltage		4				V	min	C
Max Quiescent Current	$V_S = +5V$	4.5	4.8	5.0	5.2	mA	max	A
Min Quiescent Current	$V_S = +5V$	4.5	4.1	4.0	3.8	mA	min	A
Power-Supply Rejection Ratio (-PSRR)	Input Referred	55				dB	typ	C
TEMPERATURE RANGE								
Specification: D, DBV						$^\circ C$	typ	C
Thermal Resistance, θ_{JA}	Junction-to-Ambient	-40 to +85						
D SO-8		125				$^\circ C/W$	typ	C
DBV SOT23-6		150				$^\circ C/W$	typ	C

NOTES: (3) Test levels: (A) 100% tested at 25°C. Over-temperature limits by characterization and simulation. (B) Limits set by characterization and simulation. (C) Typical value only for information. (1) Junction temperature = ambient for 25°C specifications. (2) Junction temperature = ambient at low temperature limit: junction temperature = ambient +10°C at high temperature limit for over-temperature specifications. (3) Test levels: (A) 100% tested at 25°C. Over-temperature limits by characterization and simulation. (B) Limits set by characterization and simulation. (C) Typical value only for information. (4) Current is considered positive out-of-node. V_{CM} is the input common-mode voltage. (5) Tested < 3dB below minimum specified CMRR at $\pm CMIR$ limits.

TYPICAL CHARACTERISTICS: $V_S = \pm 5V$

$G = +2$, $R_F = 402\Omega$, and $R_L = 100\Omega$, unless otherwise noted (see Figure 1).

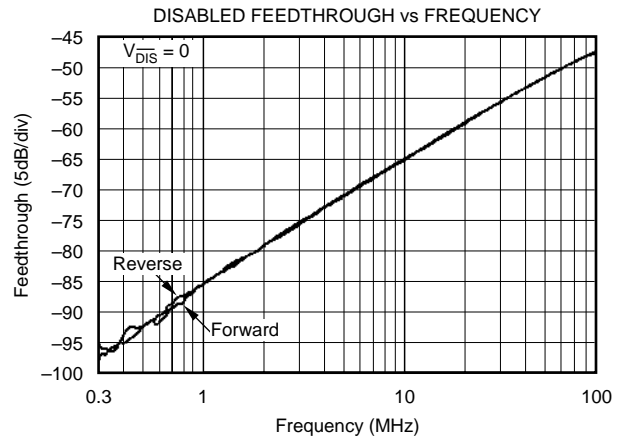
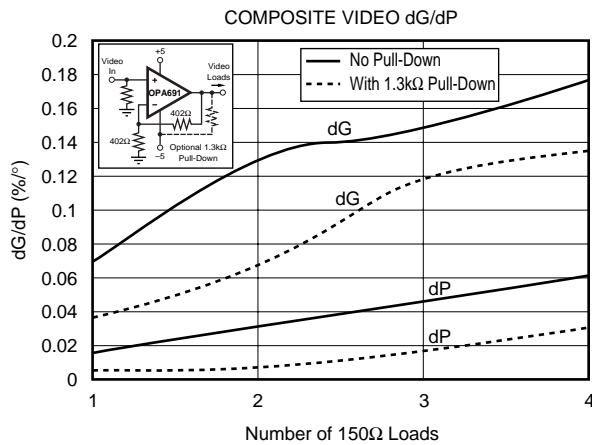
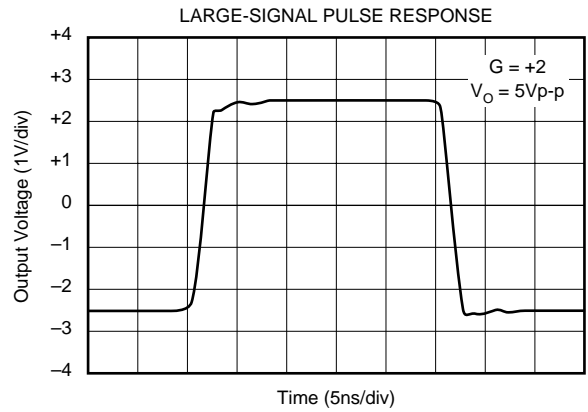
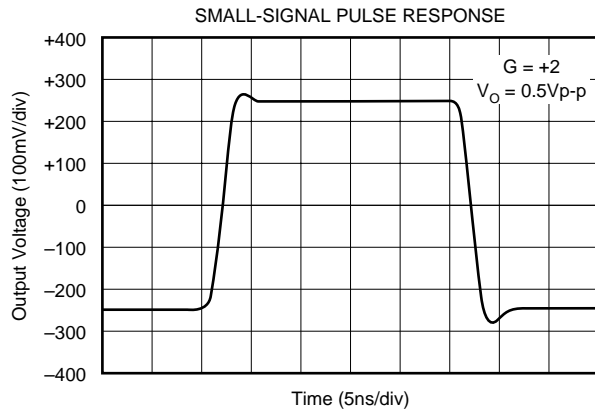
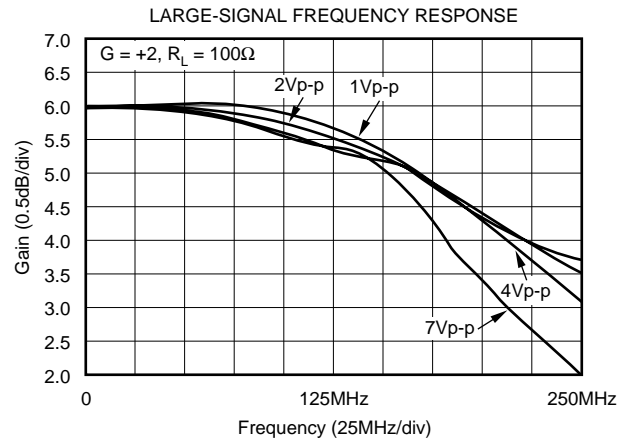
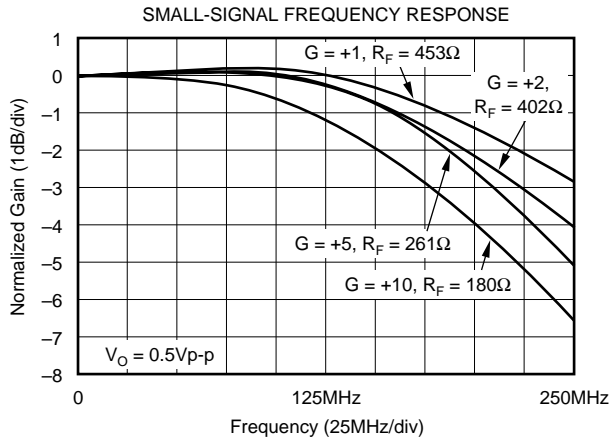

TYPICAL CHARACTERISTICS: $V_S = \pm 5V$ (Cont.)

$G = +2$, $R_F = 402\Omega$, and $R_L = 100\Omega$, unless otherwise noted (see Figure 1).

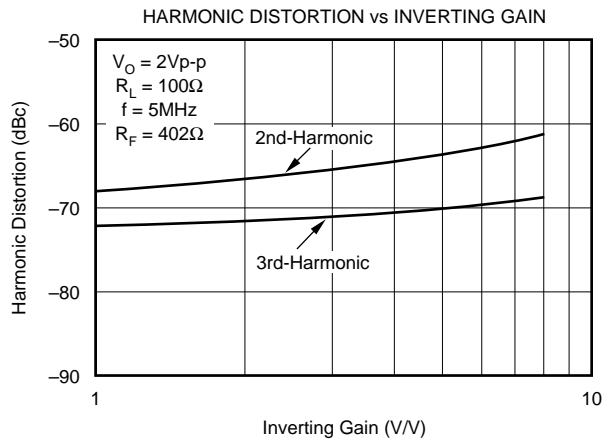
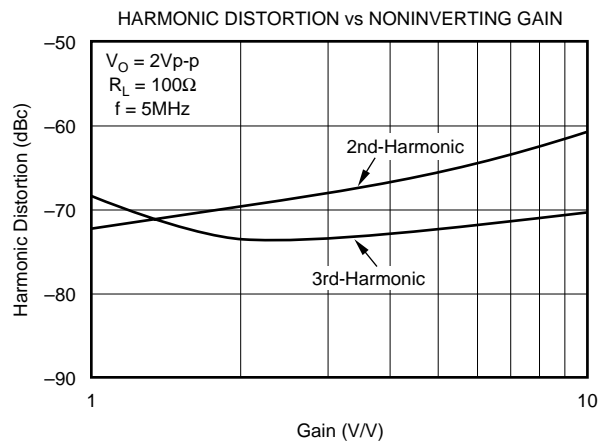
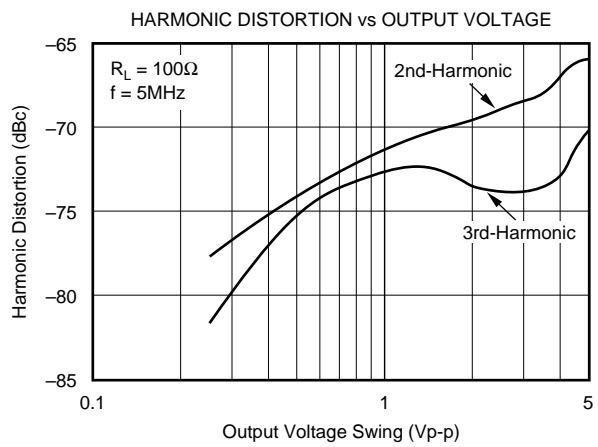
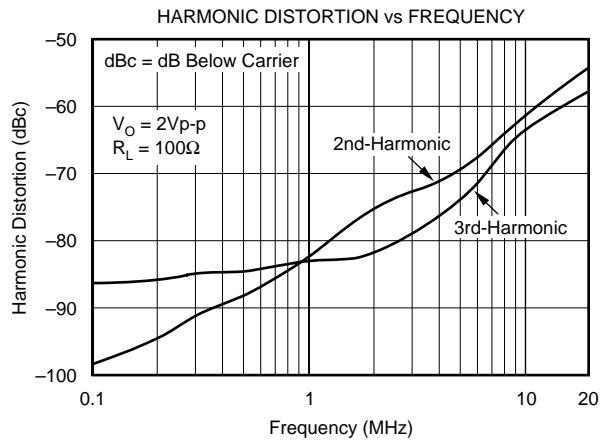
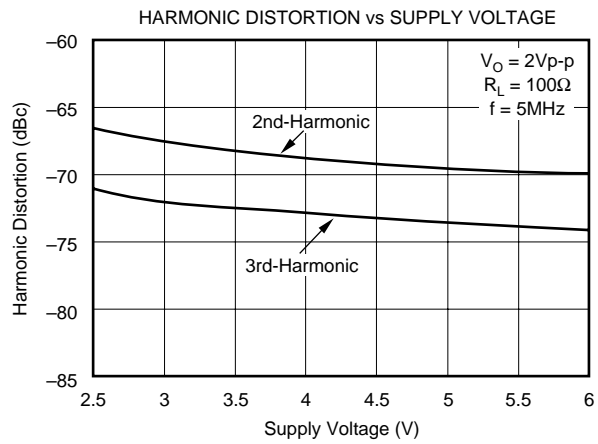
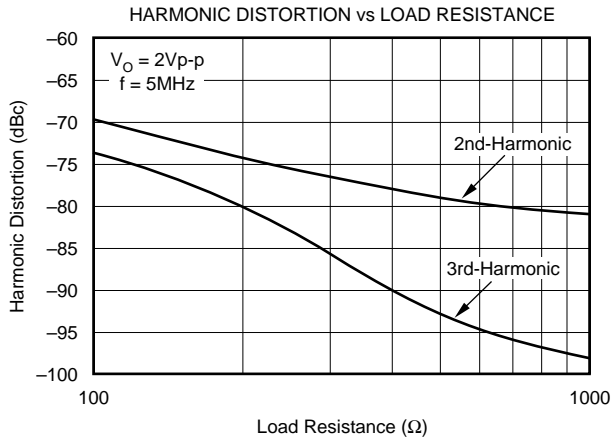

TYPICAL CHARACTERISTICS: $V_S = \pm 5V$ (Cont.)

$G = +2$, $R_F = 402\Omega$, and $R_L = 100\Omega$, unless otherwise noted (see Figure 1).

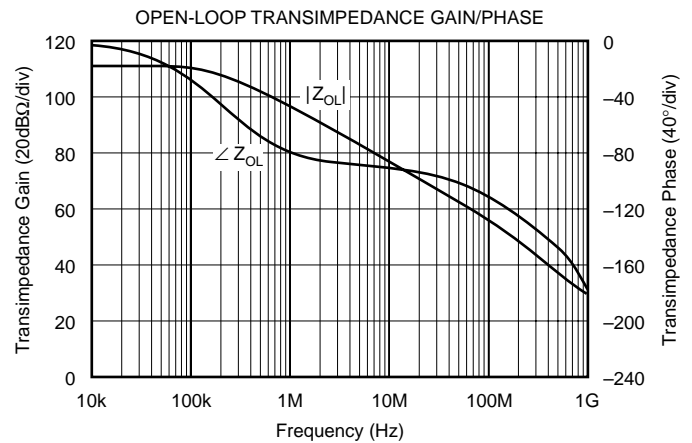
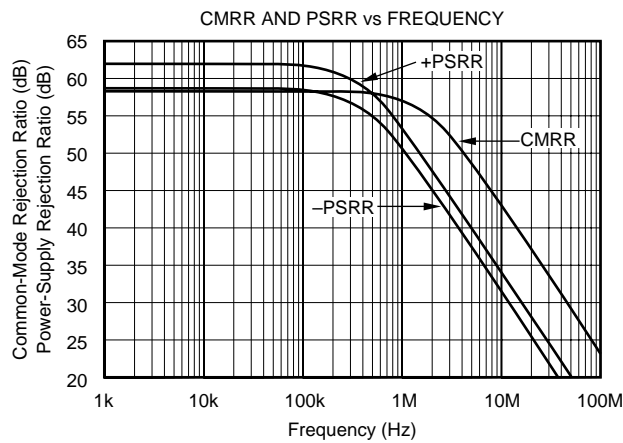
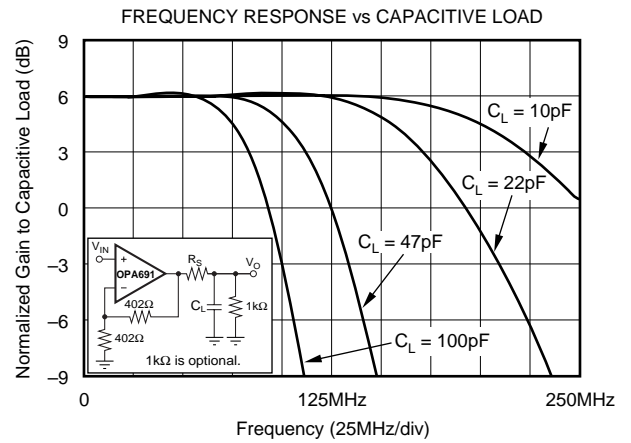
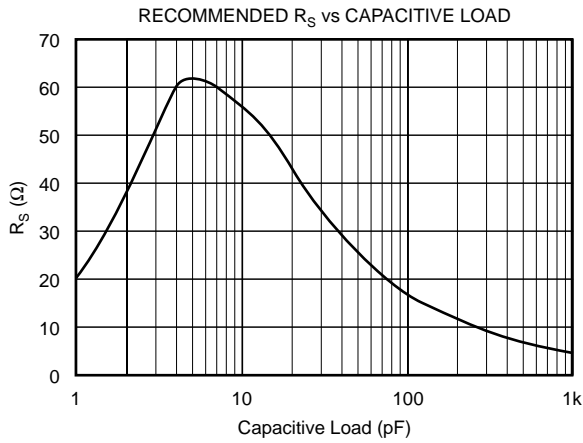
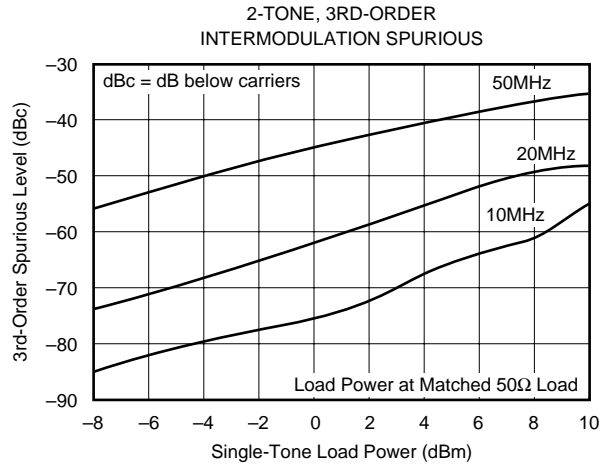
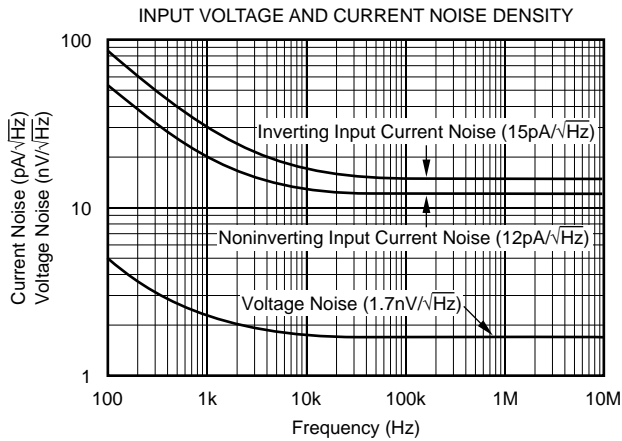

TYPICAL CHARACTERISTICS: $V_S = \pm 5V$ (Cont.)

$G = +2$, $R_F = 402\Omega$, and $R_L = 100\Omega$, unless otherwise noted (see Figure 1).

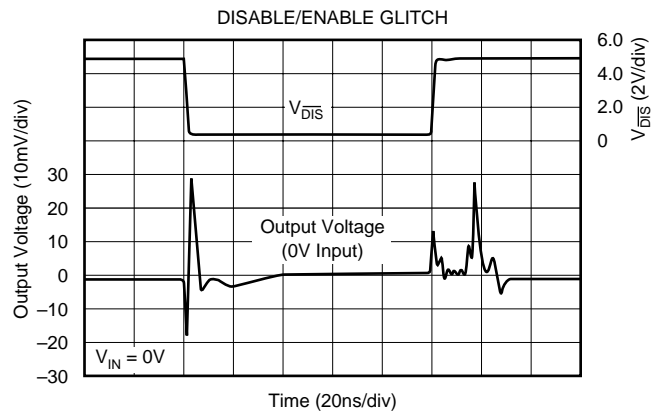
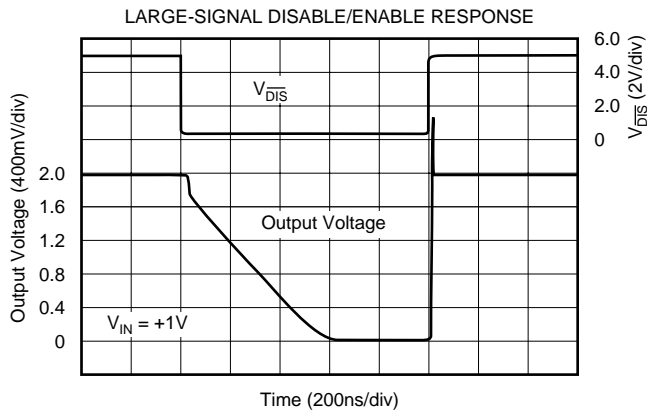
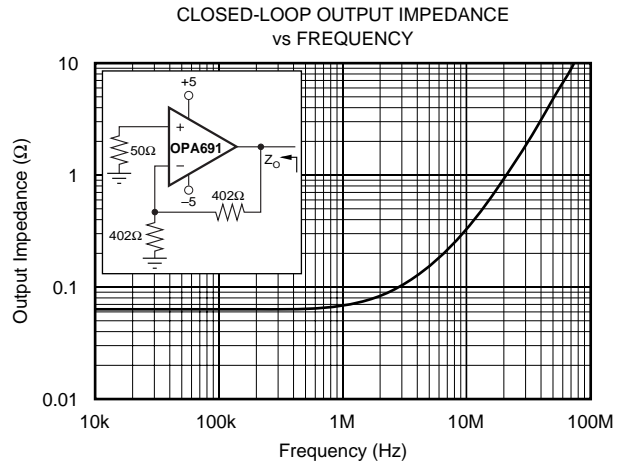
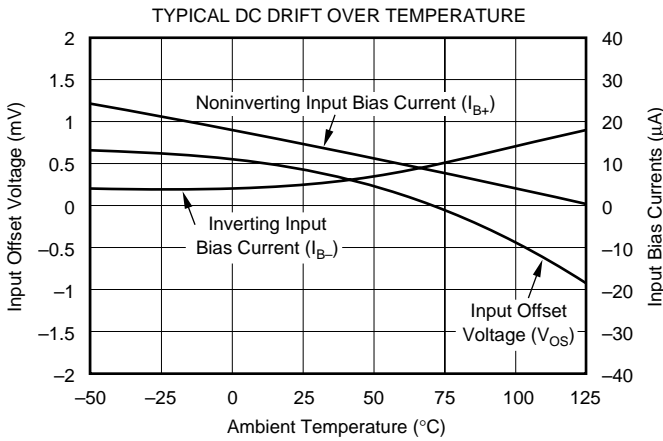
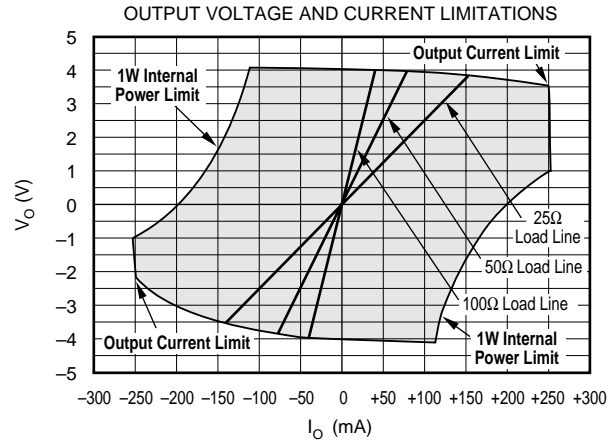
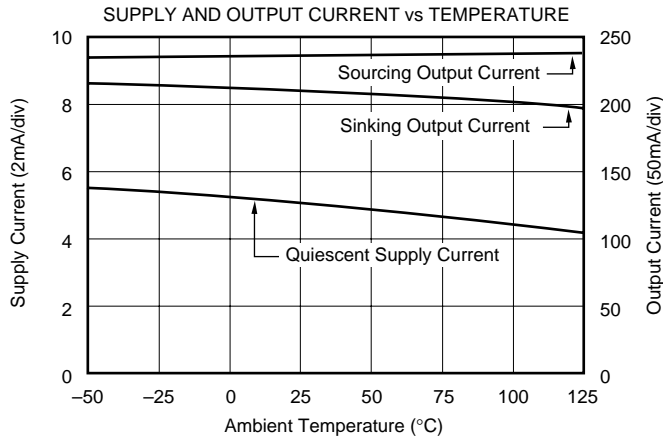

TYPICAL CHARACTERISTICS: $V_S = +5V$

$G = +2$, $R_F = 453\Omega$, and $R_L = 100\Omega$ to $+2.5V$, unless otherwise noted (see Figure 2).

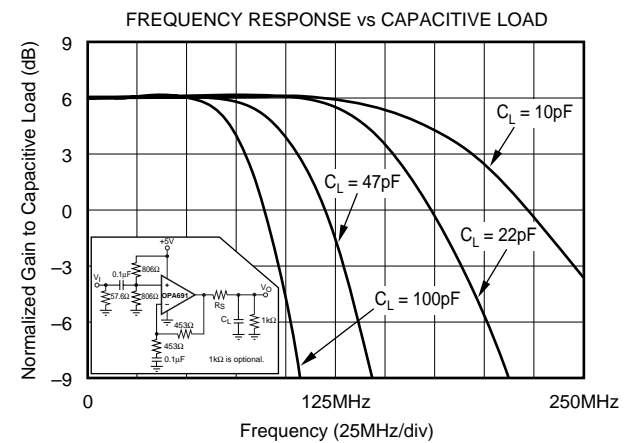
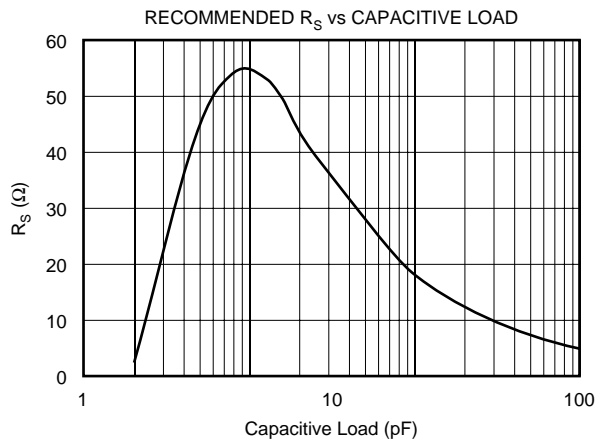
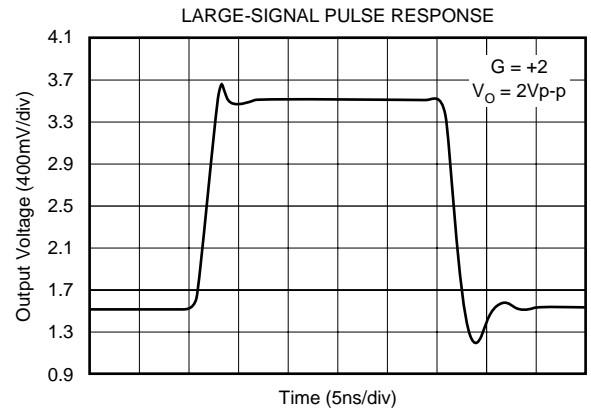
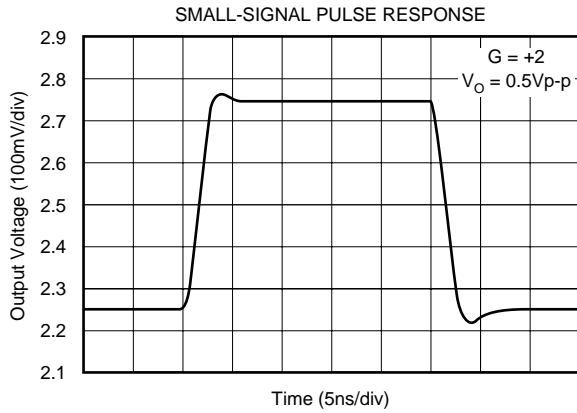
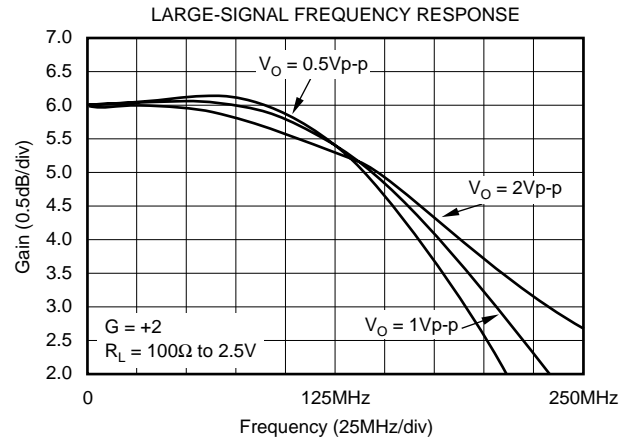
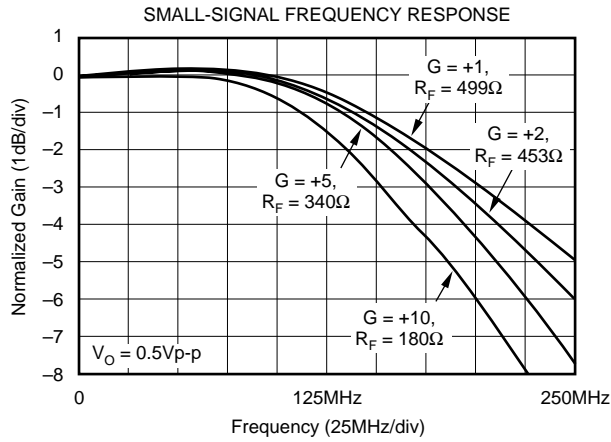

TYPICAL CHARACTERISTICS: $V_S = +5V$ (Cont.)

$G = +2$, $R_F = 453\Omega$, and $R_L = 100\Omega$ to $+2.5V$, unless otherwise noted (see Figure 2).

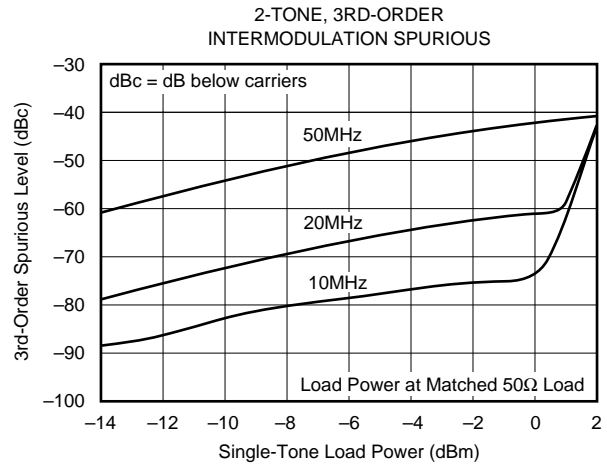
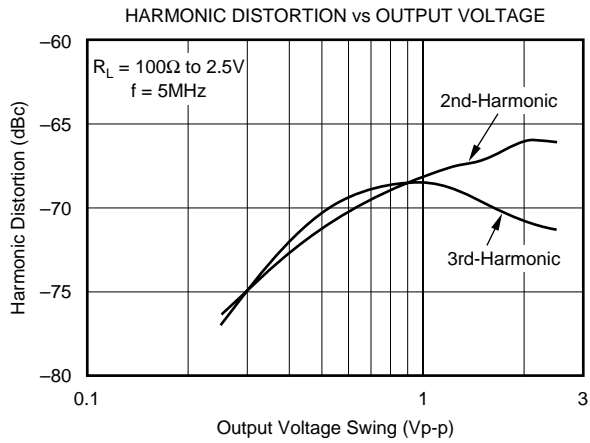
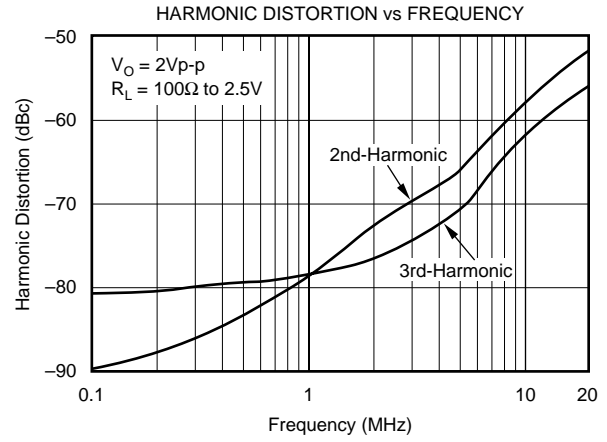
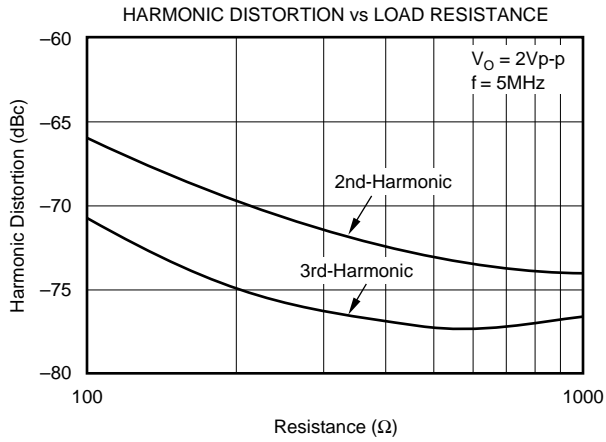

APPLICATIONS INFORMATION

WIDEBAND CURRENT FEEDBACK OPERATION

The OPA691 gives the exceptional AC performance of a wideband current feedback op amp with a highly linear, high power output stage. Requiring only 5.1mA quiescent current, the OPA691 will swing to within 1V of either supply rail and deliver in excess of 160mA at room temperature. This low output headroom requirement, along with supply voltage independent biasing, gives remarkable single (+5V) supply operation. The OPA691 will deliver greater than 200MHz bandwidth driving a 2V_{PP} output into 100Ω on a single +5V supply. Previous boosted output stage amplifiers have typically suffered from very poor crossover distortion as the output current goes through zero. The OPA691 achieves a comparable power gain with much better linearity. The primary advantage of a current feedback op amp over a voltage feedback op amp is that AC performance (bandwidth and distortion) is relatively independent of signal gain. For similar AC performance at low gains, with improved DC accuracy, consider the high slew rate, unity-gain stable, voltage feedback OPA690.

Figure 1 shows the DC-coupled, gain of +2, dual power-supply circuit configuration used as the basis of the ±5V Electrical Characteristic tables and Typical Characteristic curves. For test purposes, the input impedance is set to 50Ω with a resistor to ground and the output impedance is set to 50Ω with a series output resistor. Voltage swings reported in the specifications are taken directly at the input and output pins while load powers (dBm) are defined at a matched 50Ω load. For the circuit of Figure 1, the total effective load will be 100Ω || 804Ω = 89Ω. The disable control line ($\overline{\text{DIS}}$) is typically left open to ensure normal amplifier operation. One optional component is included in Figure 1. In addition to the usual power-supply de-coupling capacitors to ground, a 0.1μF capacitor is included between the two power-supply

pins. In practical PC board layouts, this optional added capacitor will typically improve the 2nd-harmonic distortion performance by 3dB to 6dB.

Figure 2 shows the AC-coupled, gain of +2, single-supply circuit configuration used as the basis of the +5V Electrical Characteristic tables and Typical Characteristic curves. Though not a “rail-to-rail” design, the OPA691 requires minimal input and output voltage headroom compared to other very wideband current feedback op amps. It will deliver a 3V_{PP} output swing on a single +5V supply with greater than 150MHz bandwidth. The key requirement of broadband single-supply operation is to maintain input and output signal swings within the usable voltage ranges at both the input and the output. The circuit of Figure 2 establishes an input midpoint bias using a simple resistive divider from the +5V supply (two 806Ω resistors). The input signal is then AC-coupled into this midpoint voltage bias. The input voltage can swing to within 1.5V of either supply pin, giving a 2V_{PP} input signal range centered between the supply pins. The input impedance matching resistor (57.6Ω) used for testing is adjusted to give a 50Ω input match when the parallel combination of the biasing divider network is included. The gain resistor (R_G) is AC-coupled, giving the circuit a DC gain of +1—which puts the input DC bias voltage (2.5V) on the output as well. The feedback resistor value has been adjusted from the bipolar supply condition to re-optimize for a flat frequency response in +5V, gain of +2, operation (see Setting Resistor Values to Optimize Bandwidth). Again, on a single +5V supply, the output voltage can swing to within 1V of either supply pin while delivering more than 120mA output current. A demanding 100Ω load to a mid-point bias is used in this characterization circuit. The new output stage used in the OPA691 can deliver large bipolar output currents into this mid-point load with minimal crossover distortion, as shown by the +5V supply, 3rd-harmonic distortion plots.

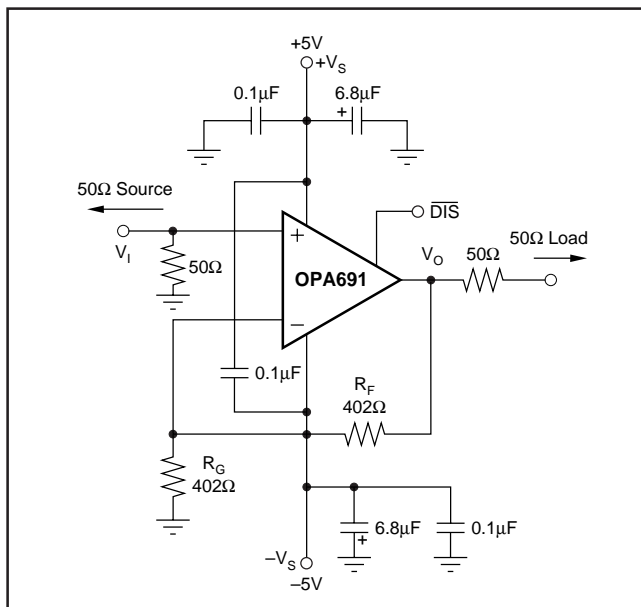

FIGURE 1. DC-Coupled, G = +2, Bipolar Supply, Specification and Test Circuit.

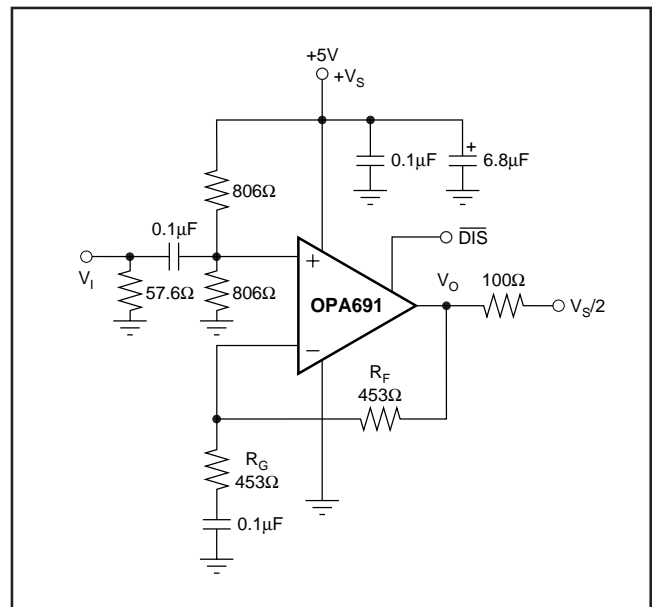

FIGURE 2. AC-Coupled, G = +2, Single-Supply Specification and Test Circuit.

SINGLE-SUPPLY ADC INTERFACE

Most modern, high performance ADCs (such as the Texas Instruments ADS8xx and ADS9xx series) operate on a single +5V (or lower) power supply. It has been a considerable challenge for single-supply op amps to deliver a low distortion input signal at the ADC input for signal frequencies exceeding 5MHz. The high slew rate, exceptional output swing, and high linearity of the OPA691 make it an ideal single-supply ADC driver. Figure 3 shows an example input interface to a very high performance, 10-bit, 60MSPS CMOS converter.

The OPA691 in the circuit of Figure 3 provides > 180MHz bandwidth operating at a signal gain of +4 with a 2V_{pp} output swing. One of the primary advantages of the current feedback internal architecture used in the OPA691 is that high bandwidth can be maintained as the signal gain is increased. The noninverting input bias voltage is referenced to the midpoint of the ADC signal range by dividing off the top and bottom of the internal ADC reference ladder. With the gain resistor (R_G) AC-coupled, this bias voltage has a gain of +1 to the output, centering the output voltage swing as well. Tested performance at a 20MHz analog input frequency and a 60MSPS clock rate on the converter gives > 58dBc SFDR.

WIDEBAND INVERTING SUMMING AMPLIFIER

Since the signal bandwidth for a current feedback op amp may be controlled independently of the noise gain (NG, which is normally the same as the noninverting signal gain), very broadband inverting summing stages may be implemented using the OPA691. The circuit on the front page of this data sheet shows an example inverting summing amplifier where the resistor values have been adjusted to maintain both maximum bandwidth and input impedance matching. If each RF signal is assumed to be driven from a 50Ω source, the NG for this circuit will be $(1 + 100\Omega / (100\Omega / 5)) = 6$. The total feedback impedance (from V_O to the inverting error current) is

the sum of R_F + (R_I • NG) where R_I is the impedance looking into the inverting input from the summing junction (see the Setting Resistor Values to Optimize Performance section). Using 100Ω feedback (to get a signal gain of -2 from each input to the output pin) requires an additional 30Ω in series with the inverting input to increase the feedback impedance. With this resistor added to the typical internal R_I = 35Ω, the total feedback impedance is 100Ω + (65Ω • 6) = 490Ω, which is equal to the required value to get a maximum bandwidth flat frequency response for NG = 6. Tested performance shows more than 200MHz small-signal bandwidth and a -1dBm compression of 15dBm at the matched 50Ω load through 100MHz.

WIDEBAND VIDEO MULTIPLEXING

One common application for video speed amplifiers which include a disable pin is to wire multiple amplifier outputs together, then select which one of several possible video inputs to source onto a single line. This simple “Wired-OR Video Multiplexer” can be easily implemented using the OPA691, see Figure 4.

Typically, channel switching is performed either on sync or retrace time in the video signal. The two inputs are approximately equal at this time. The “make-before-break” disable characteristic of the OPA691 ensures that there is always one amplifier controlling the line when using a wired-OR circuit like that presented in Figure 4. Since both inputs may be on for a short period during the transition between channels, the outputs are combined through the output impedance matching resistors (82.5Ω in this case). When one channel is disabled, its feedback network forms part of the output impedance and slightly attenuates the signal in getting out onto the cable. The gain and output matching resistor have been slightly increased to get a signal gain of +1 at the matched load and provide a 75Ω output impedance to the cable. The video multiplexer connection (see Figure 4)

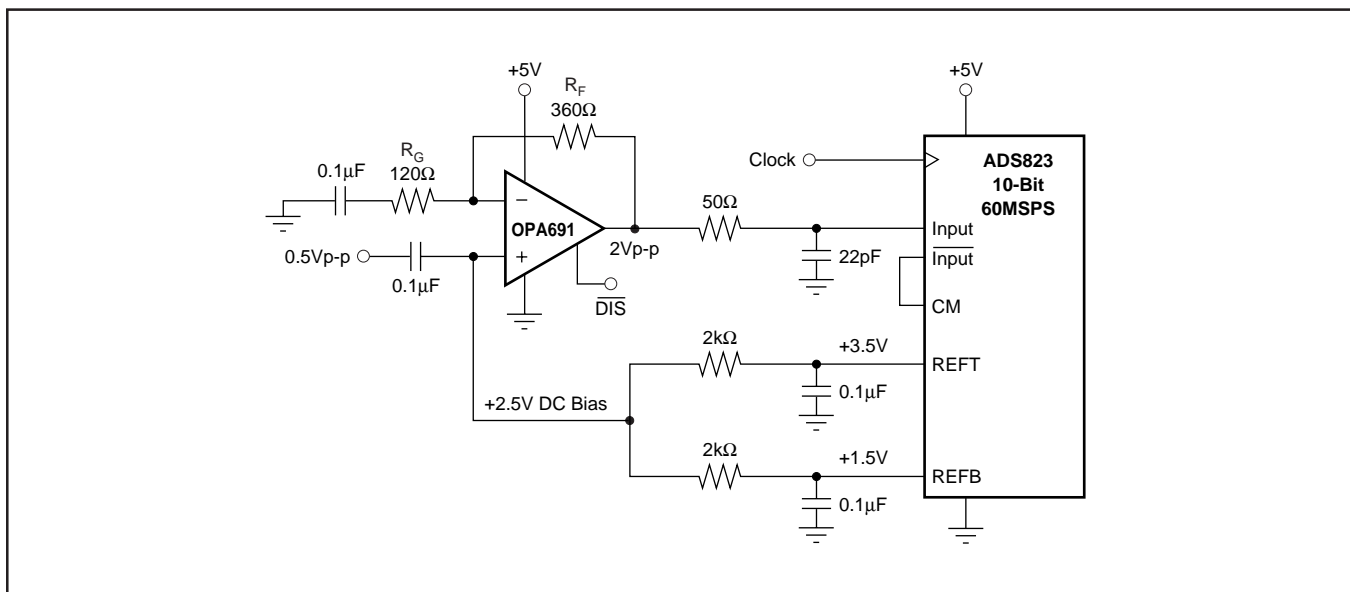

FIGURE 3. Wideband, AC-Coupled, Single-Supply ADC Driver.

also ensures that the maximum differential voltage across the inputs of the unselected channel do not exceed the rated $\pm 1.2V$ maximum for standard video signal levels.

The section on Disable Operation shows the turn-on and turn-off switching glitches using a grounded input for a single channel is typically less than $\pm 50mV$. Where two outputs are switched (see Figure 6), the output line is always under the

control of one amplifier or the other due to the “make-before-break” disable timing. In this case, the switching glitches for two 0V inputs drop to $< 20mV$.

4-CHANNEL FREQUENCY CHANNELIZER

The circuit of Figure 5 is a 4-channel multiplexer. In this circuit the OPA691 provides the drive for all 4 channels.

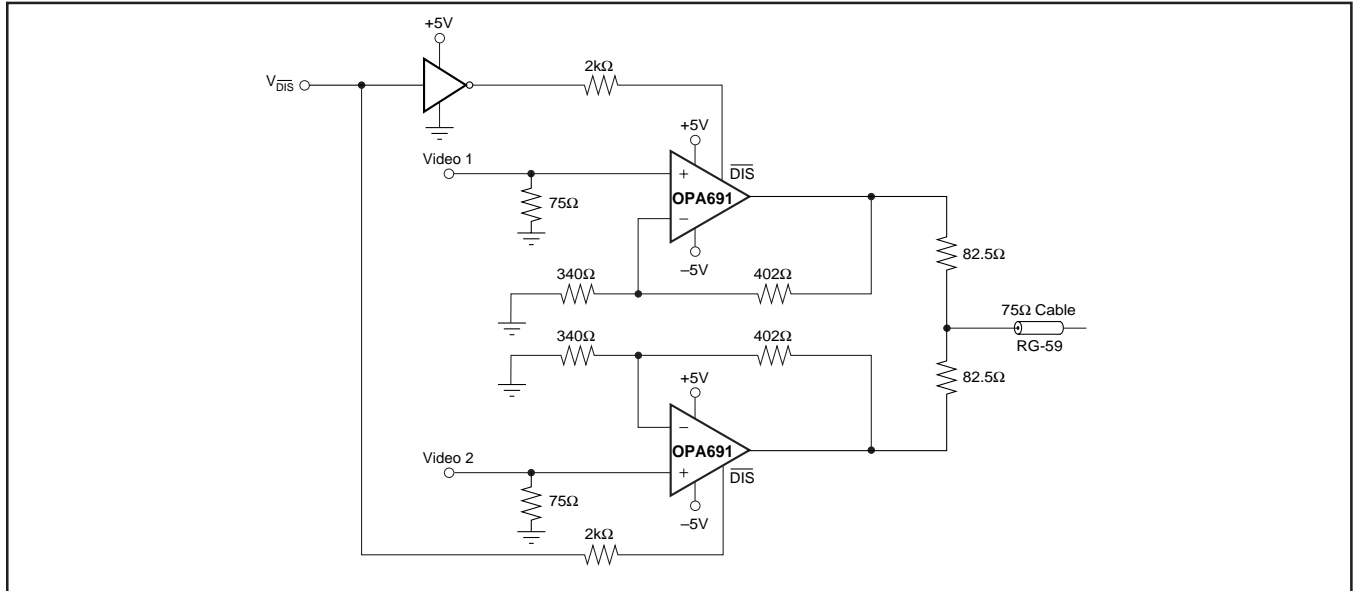

FIGURE 4. 2-Channel Video Multiplexer.

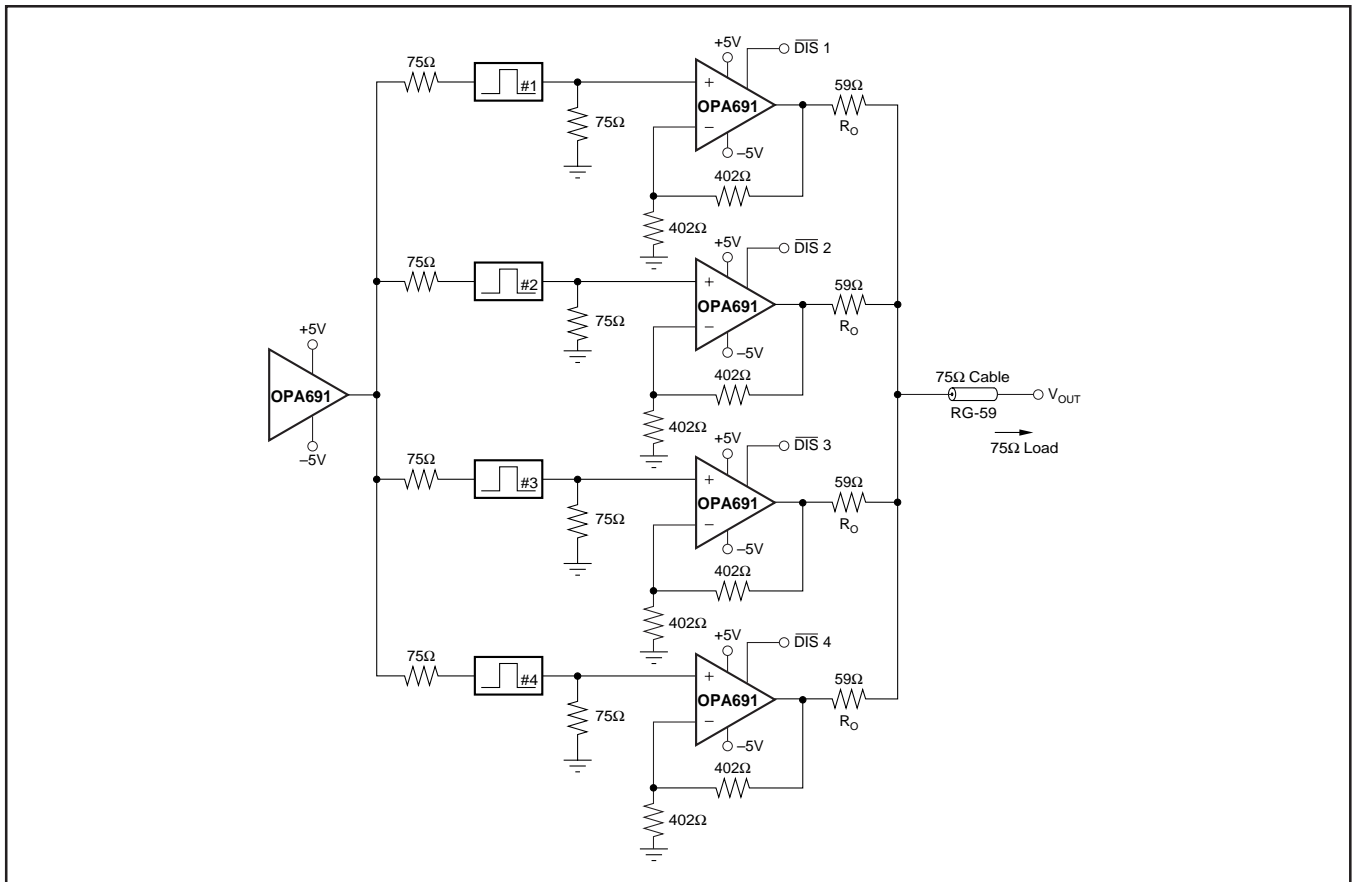

FIGURE 5. 4-Channel Frequency Channelizer.

Each channel includes a bandpass filter. Each bandpass filter is set for a different frequency band. This allows the channelizing part of this circuit. The role of the channelizers OPA691s is to provide impedance isolation. This is done through the use of four matching resistances (59Ω in this case). These matching resistors ensure that the signals will combine during the transition between channels. They have been used to get a gain of +1 at the load.

This circuit may be used with a different number of channels. Its limitation comes from the drive requirement for each channel as well as the minimum acceptable return loss.

The output resistor value (R_O) to keep a gain of +1 at the load depends on the number of channels. For the OPA691 with a gain of 2 using $R_F = 402\Omega$ and $R_G = 402\Omega$, Equation 1 is:

$$R_O = \frac{[75\Omega \cdot (n-1) + 804\Omega]}{2} \cdot \left(\sqrt{1 + \frac{241200\Omega}{[75\Omega \cdot (n-1) + 804\Omega]}} - 1 \right) \quad (1)$$

SINGLE-SUPPLY "IF" AMPLIFIER

The high bandwidth provided by the OPA691 while operating on a single +5V supply lends itself well to IF amplifier applications. One of the advantages of using an op amp like the OPA691 as an IF amplifier is that precise signal gain is achieved along with much lower 3rd-order intermodulation versus quiescent power dissipation. In addition, the OPA691 in the SOT23-6 package offers a very small package with a power shutdown feature for portable applications. One concern with using op amps for an IF amplifier is their relatively high noise figures. It is sometimes suggested that an optimum source resistance can be used to minimize op amp noise figures. Adding a resistor to reach this optimum value may improve the noise figure, but will actually decrease the signal-to-noise ratio. A more effective way to move towards an optimum source impedance is to bring the signal in through an input transformer. Figure 6 shows an example that is particularly useful for the OPA691.

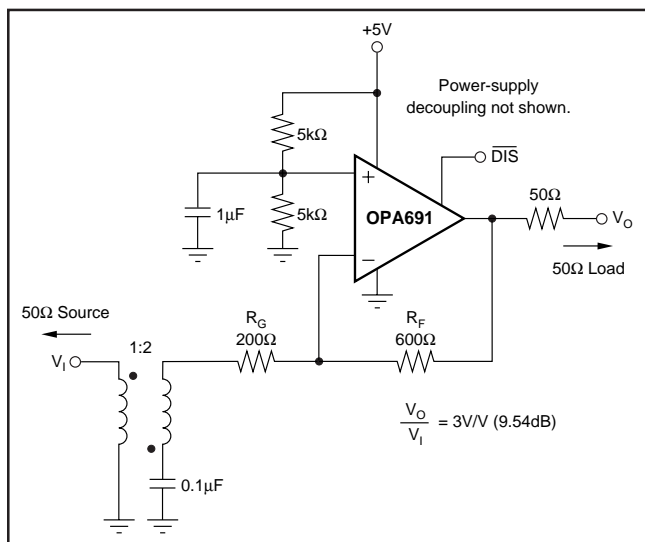

FIGURE 6. Low-Noise, Single-Supply IF Amplifier.

Bringing the signal in through a step-up transformer to the inverting input gain resistor has several advantages for the OPA691. First, the decoupling capacitor on the noninverting input eliminates the contribution of the noninverting input current noise to the output noise. Secondly, the noninverting input noise voltage of the op amp is actually attenuated if reflected to the input side of R_G . Using the 1:2 (turns ratio) step-up transformer reflects the 50Ω source impedance at the primary through to the secondary as a 200Ω source impedance (and the 200Ω R_G resistor is reflected through to the transformer primary as a 50Ω input matching impedance). The noise gain to the amplifier output is then $1 + 600/400 = 2.5V/V$. Taking the op amp's $2.2nV/\sqrt{Hz}$ input voltage noise times this noise gain to the output, then reflecting this noise term to the input side of the R_G resistor, divides it by 3. This gives a net gain of 0.833 for the noninverting input voltage noise when reflected to the input point for the op amp circuit. This is further reduced when referred back to the transformer primary.

The relatively low-gain IF amplifier circuit of Figure 6 gives a 12dB noise figure at the input of the transformer. Increasing the R_F resistor to 600Ω (once R_G is set to 200Ω for input impedance matching) will slightly reduce the bandwidth. Measured results show 150MHz small-signal bandwidth for the circuit of Figure 6 with exceptional flatness through 30MHz. Although the OPA691 does not show an intercept characteristic for the 2-tone, 3rd-order intermodulation distortion, it does hold a very high Spurious-Free Dynamic Range (SFDR) through high output powers and frequencies. The maximum single-tone power at the matched load for the single-supply circuit of Figure 6 is 1dBm (this requires a $2.8V_{PP}$ swing at the output pin of the OPA691 for the 2-tone envelope). Measured 2-tone SFDR at this maximum load power for the circuit of Figure 6 exceeds 55dBc for frequencies to 20MHz.

DESIGN-IN TOOLS

DEMONSTRATION FIXTURES

Two printed circuit boards (PCBs) are available to assist in the initial evaluation of circuit performance using the OPA691 in its two package options. Both of these are offered free of charge as unpopulated PCBs, delivered with a user's guide. The summary information for these fixtures is shown in the table below.

PRODUCT	PACKAGE	ORDERING NUMBER	LITERATURE NUMBER
OPA691ID	SO-8	DEM-OPA-SO-1A	SBOU009
OPA691IDBV	SOT23-6	DEM-OPA-SOT-1A	SBOU010

The demonstration fixtures can be requested at the Texas Instruments web site (www.ti.com) through the OPA691 product folder.

MACROMODELS AND APPLICATIONS SUPPORT

Computer simulation of circuit performance using SPICE is often useful when analyzing the performance of analog circuits and systems. This is particularly true for video and RF

amplifier circuits where parasitic capacitance and inductance can have a major effect on circuit performance. A SPICE model for the OPA691 is available through the TI web site (www.ti.com). These models do a good job of predicting small-signal AC and transient performance under a wide variety of operating conditions. They do not do as well in predicting the harmonic distortion or $dG/d\phi$ characteristics. These models do not attempt to distinguish between the package types in their small-signal AC performance.

OPERATING SUGGESTIONS

SETTING RESISTOR VALUES TO OPTIMIZE BANDWIDTH

A current feedback op amp like the OPA691 can hold an almost constant bandwidth over signal gain settings with the proper adjustment of the external resistor values. This is shown in the Typical Characteristic curves; the small-signal bandwidth decreases only slightly with increasing gain. Those curves also show that the feedback resistor has been changed for each gain setting. The resistor “values” on the inverting side of the circuit for a current feedback op amp can be treated as frequency response compensation elements while their “ratios” set the signal gain. Figure 7 shows the small-signal frequency response analysis circuit for the OPA691.

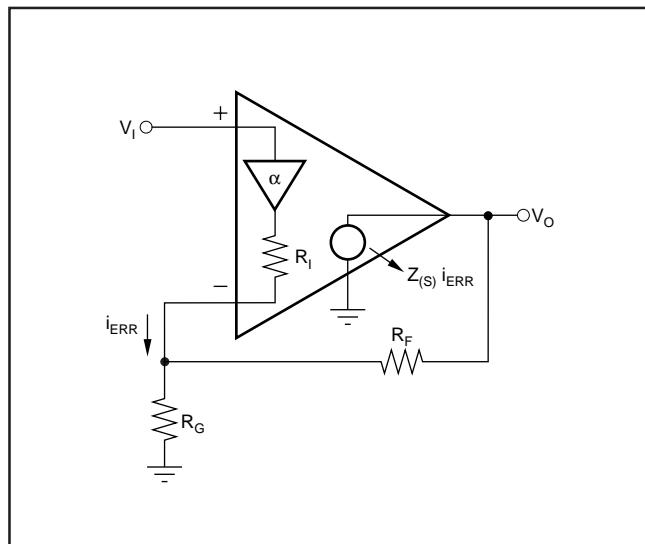

FIGURE 7. Recommended Feedback Resistor versus Noise Gain.

The key elements of this current feedback op amp model are:

α → Buffer gain from the noninverting input to the inverting input

R_I → Buffer output impedance

i_{ERR} → Feedback error current signal

$Z(s)$ → Frequency dependent open-loop transimpedance gain from i_{ERR} to V_O

The buffer gain is typically very close to 1.00 and is normally neglected from signal gain considerations. It will, however, set the CMRR for a single op amp differential amplifier configuration. For a buffer gain $\alpha < 1.0$, the CMRR = $-20 \cdot \log(1 - \alpha)$ dB.

R_I , the buffer output impedance, is a critical portion of the bandwidth control equation. The OPA691 is typically about 35Ω .

A current feedback op amp senses an error current in the inverting node (as opposed to a differential input error voltage for a voltage feedback op amp) and passes this on to the output through an internal frequency dependent transimpedance gain. The Typical Characteristics show this open-loop transimpedance response. This is analogous to the open-loop voltage gain curve for a voltage feedback op amp. Developing the transfer function for the circuit of Figure 7 gives Equation 1:

$$\frac{V_O}{V_I} = \frac{\alpha \left(1 + \frac{R_F}{R_G} \right)}{R_F + R_I \left(1 + \frac{R_F}{R_G} \right) + \frac{Z(s)}{1 + \frac{R_F}{R_G}}} = \frac{\alpha NG}{1 + \frac{R_F + R_I NG}{Z_S}} \quad (2)$$

$$\left[NG = \left(1 + \frac{R_F}{R_G} \right) \right]$$

This is written in a loop-gain analysis format where the errors arising from a non-infinite open-loop gain are shown in the denominator. If $Z(s)$ were infinite over all frequencies, the denominator of Equation 1 would reduce to 1 and the ideal desired signal gain shown in the numerator would be achieved. The fraction in the denominator of Equation 1 determines the frequency response. Equation 2 shows this as the loop-gain equation:

$$\frac{Z(s)}{R_F + R_I NG} = \text{Loop Gain} \quad (3)$$

If $20 \cdot \log(R_F + NG \cdot R_I)$ were drawn on top of the open-loop transimpedance plot, the difference between the two would be the loop gain at a given frequency. Eventually, $Z(s)$ rolls off to equal the denominator of Equation 2 at which point the loop gain has reduced to 1 (and the curves have intersected). This point of equality is where the amplifier's closed-loop frequency response given by Equation 1 will start to roll off, and is exactly analogous to the frequency at which the noise gain equals the open-loop voltage gain for a voltage feedback op amp. The difference here is that the total impedance in the denominator of Equation 2 may be controlled somewhat separately from the desired signal gain (or NG).

The OPA691 is internally compensated to give a maximally flat frequency response for $R_F = 402\Omega$ at $NG = 2$ on $\pm 5V$ supplies. Evaluating the denominator of Equation 2 (which is the feedback transimpedance) gives an optimal target of 472Ω . As the signal gain changes, the contribution of the $NG \cdot R_I$ term in the feedback transimpedance will change, but the total can be held constant by adjusting R_F . Equation 4 gives an approximate equation for optimum R_F over signal gain:

$$R_F = 472\Omega - NG R_I \quad (4)$$

As the desired signal gain increases, this equation will eventually predict a negative R_F . A somewhat subjective limit to this adjustment can also be set by holding R_G to a minimum value of 20Ω . Lower values will load both the buffer stage at the input and the output stage if R_F gets too low—actually decreasing the bandwidth. Figure 8 shows the recommended R_F versus NG for both $\pm 5V$ and a single $+5V$ operation. The values for R_F versus gain shown here are approximately equal to the values used to generate the Typical Characteristics. They differ in that the optimized values used in the Typical Characteristics are also correcting for board parasitics not considered in the simplified analysis leading to Equation 3. The values shown in Figure 8 give a good starting point for design where bandwidth optimization is desired.

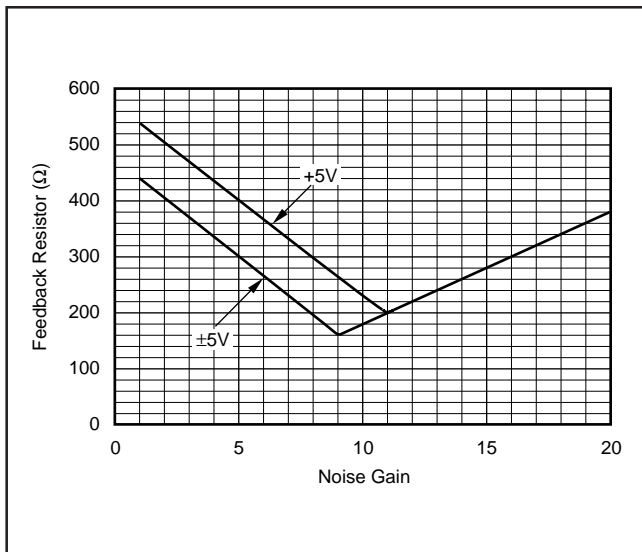

FIGURE 8. Feedback Resistor vs Noise Gain.

The total impedance going into the inverting input may be used to adjust the closed-loop signal bandwidth. Inserting a series resistor between the inverting input and the summing junction will increase the feedback impedance (denominator of Equation 2), decreasing the bandwidth. This approach to bandwidth control is used for the inverting summing circuit on the front page. The internal buffer output impedance for the OPA691 is slightly influenced by the source impedance looking out of the noninverting input terminal. High source resistors will have the effect of increasing R_i , decreasing the bandwidth. For those single-supply applications which develop a midpoint bias at the noninverting input through high valued resistors, the decoupling capacitor is essential for power-supply noise rejection, noninverting input noise current shunting, and to minimize the high frequency value for R_i in Figure 7.

INVERTING AMPLIFIER OPERATION

Since the OPA691 is a general-purpose, wideband current feedback op amp, most of the familiar op amp application circuits are available to the designer. Those applications that require considerable flexibility in the feedback element

(e.g., integrators, transimpedance, and some filters) should consider the unity-gain stable voltage feedback OPA680, since the feedback resistor is the compensation element for a current feedback op amp. Wideband inverting operation (and especially summing) is particularly suited to the OPA691. See Figure 9 for a typical inverting configuration where the I/O impedances and signal gain from Figure 1 are retained in an inverting circuit configuration.

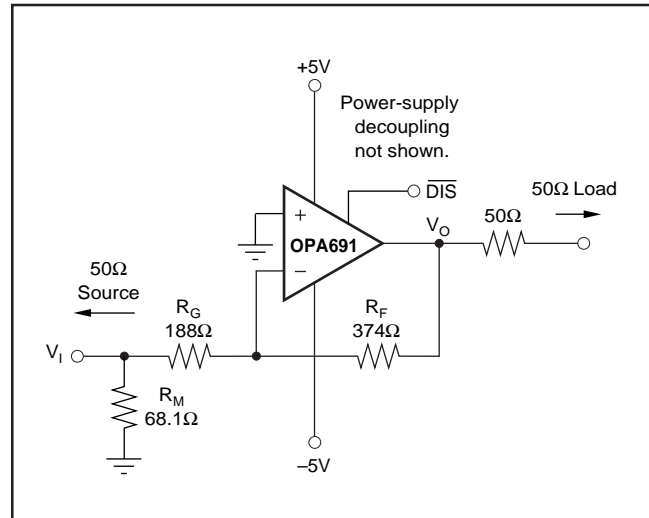

FIGURE 9. Inverting Gain of -2 with Impedance Matching.

In the inverting configuration, two key design considerations must be noted. The first is that the gain resistor (R_G) becomes part of the signal channel input impedance. If input impedance matching is desired (which is beneficial whenever the signal is coupled through a cable, twisted-pair, long PC board trace, or other transmission line conductor), it is normally necessary to add an additional matching resistor to ground. R_G by itself is normally not set to the required input impedance since its value, along with the desired gain, will determine an R_F which may be non-optimal from a frequency response standpoint. The total input impedance for the source becomes the parallel combination of R_G and R_M .

The second major consideration, touched on in the previous paragraph, is that the signal source impedance becomes part of the noise gain equation and will have slight effect on the bandwidth through Equation 1. The values shown in Figure 9 have accounted for this by slightly decreasing R_F (from Figure 1) to re-optimize the bandwidth for the noise gain of Figure 9 ($NG = 2.73$). In the example of Figure 9, the R_M value combines in parallel with the external 50Ω source impedance, yielding an effective driving impedance of $50\Omega \parallel 68\Omega = 28.8\Omega$. This impedance is added in series with R_G for calculating the noise gain—which gives $NG = 2.73$. This value, along with the R_F of Figure 9 and the inverting input impedance of 35Ω , are inserted into Equation 3 to get a feedback transimpedance nearly equal to the 472Ω optimum value.

Note that the noninverting input in this bipolar supply inverting application is connected directly to ground. It is often suggested that an additional resistor be connected to ground

on the noninverting input to achieve bias current error cancellation at the output. The input bias currents for a current feedback op amp are not generally matched in either magnitude or polarity. Connecting a resistor to ground on the noninverting input of the OPA691 in the circuit of Figure 9 will actually provide additional gain for that input's bias and noise currents, but will not decrease the output DC error since the input bias currents are not matched.

OUTPUT CURRENT AND VOLTAGE

The OPA691 provides output voltage and current capabilities that are unsurpassed in a low-cost monolithic op amp. Under no-load conditions at 25°C, the output voltage typically swings closer than 1V to either supply rail; the +25°C swing limit is within 1.2V of either rail. Into a 15Ω load (the minimum tested load), it is tested to deliver more than ±160mA.

The specifications described above, though familiar in the industry, consider voltage and current limits separately. In many applications, it is the voltage • current, or V-I product, which is more relevant to circuit operation. Refer to the “Output Voltage and Current Limitations” plot in the Typical Characteristics. The X- and Y-axes of this graph show the zero-voltage output current limit and the zero-current output voltage limit, respectively. The four quadrants give a more detailed view of the OPA691's output drive capabilities, noting that the graph is bounded by a “Safe Operating Area” of 1W maximum internal power dissipation. Superimposing resistor load lines onto the plot shows that the OPA691 can drive ±2.5V into 25Ω or ±3.5V into 50Ω without exceeding the output capabilities or the 1W dissipation limit. A 100Ω load line (the standard test circuit load) shows the full ±3.9V output swing capability, as shown in the Typical Specifications.

The minimum specified output voltage and current over-temperature are set by worst-case simulations at the cold temperature extreme. Only at cold startup will the output current and voltage decrease to the numbers shown in the Electrical Characteristic tables. As the output transistors deliver power, their junction temperatures will increase, decreasing their V_{BE} 's (increasing the available output voltage swing) and increasing their current gains (increasing the available output current). In steady-state operation, the available output voltage and current will always be greater than that shown in the over-temperature specifications since the output stage junction temperatures will be higher than the minimum specified operating ambient.

To protect the output stage from accidental shorts to ground and the power supplies, output short-circuit protection is included in the OPA691. The circuit acts to limit the maximum source or sink current to approximately 250mA.

DRIVING CAPACITIVE LOADS

One of the most demanding and yet very common load conditions for an op amp is capacitive loading. Often, the capacitive load is the input of an ADC—including additional external capacitance which may be recommended to im-

prove ADC linearity. A high-speed, high open-loop gain amplifier like the OPA691 can be very susceptible to decreased stability and closed-loop response peaking when a capacitive load is placed directly on the output pin. When the amplifier's open-loop output resistance is considered, this capacitive load introduces an additional pole in the signal path that can decrease the phase margin. Several external solutions to this problem have been suggested. When the primary considerations are frequency response flatness, pulse response fidelity, and/or distortion, the simplest and most effective solution is to isolate the capacitive load from the feedback loop by inserting a series isolation resistor between the amplifier output and the capacitive load. This does not eliminate the pole from the loop response, but rather shifts it and adds a zero at a higher frequency. The additional zero acts to cancel the phase lag from the capacitive load pole, thus increasing the phase margin and improving stability.

The Typical Characteristics show the recommended R_S versus Capacitive Load and the resulting frequency response at the load. Parasitic capacitive loads greater than 2pF can begin to degrade the performance of the OPA691. Long PC board traces, unmatched cables, and connections to multiple devices can easily cause this value to be exceeded. Always consider this effect carefully, and add the recommended series resistor as close as possible to the OPA691 output pin (see Board Layout Guidelines).

DISTORTION PERFORMANCE

The OPA691 provides good distortion performance into a 100Ω load on ±5V supplies. Relative to alternative solutions, it provides exceptional performance into lighter loads and/or operating on a single +5V supply. Generally, until the fundamental signal reaches very high frequency or power levels, the 2nd-harmonic will dominate the distortion with a negligible 3rd-harmonic component. Focusing then on the 2nd-harmonic, increasing the load impedance improves distortion directly. Remember that the total load includes the feedback network—in the noninverting configuration (see Figure 1) this is the sum of $R_F + R_G$, while in the inverting configuration it is just R_F . Also, providing an additional supply decoupling capacitor (0.1μF) between the supply pins (for bipolar operation) improves the 2nd-order distortion slightly (3dB to 6dB).

In most op amps, increasing the output voltage swing increases harmonic distortion directly. The Typical Characteristics show the 2nd-harmonic increasing at a little less than the expected 2x rate while the 3rd-harmonic increases at a little less than the expected 3x rate. Where the test power doubles, the 2nd-harmonic increases by less than the expected 6dB while the 3rd-harmonic increases by less than the expected 12dB. This also shows up in the 2-tone, 3rd-order intermodulation spurious (IM3) response curves. The 3rd-order spurious levels are extremely low at low output power levels. The output stage continues to hold them low even as the fundamental power reaches very high levels. As the Typical Characteristics show, the spurious intermodulation powers do not increase as predicted by a traditional intercept model. As the fundamental power level increases, the

dynamic range does not decrease significantly. For two tones centered at 20MHz, with 10dBm/tone into a matched 50Ω load (i.e., 2V_{pp} for each tone at the load, which requires 8V_{pp} for the overall 2-tone envelope at the output pin), the Typical Characteristics show 48dBc difference between the test-tone power and the 3rd-order intermodulation spurious levels. This exceptional performance improves further when operating at lower frequencies.

NOISE PERFORMANCE

Wideband current feedback op amps generally have a higher output noise than comparable voltage feedback op amps. The OPA691 offers an excellent balance between voltage and current noise terms to achieve low output noise. The inverting current noise (15pA/√Hz) is significantly lower than earlier solutions while the input voltage noise (1.7nV/√Hz) is lower than most unity-gain stable, wideband, voltage feedback op amps. This low input voltage noise was achieved at the price of higher noninverting input current noise (12pA/√Hz). As long as the AC source impedance looking out of the noninverting node is less than 100Ω, this current noise will not contribute significantly to the total output noise. The op amp input voltage noise and the two input current noise terms combine to give low output noise under a wide variety of operating conditions. Figure 10 shows the op amp noise analysis model with all the noise terms included. In this model, all noise terms are taken to be noise voltage or current density terms in either nV/√Hz or pA/√Hz.

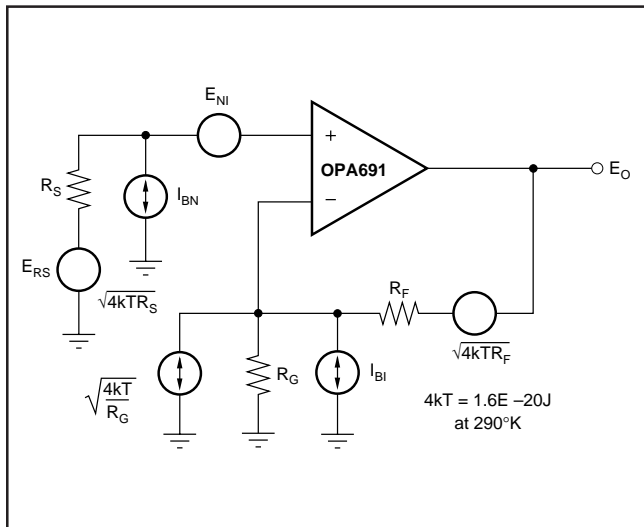

FIGURE 10. Op Amp Noise Analysis Model.

The total output spot noise voltage can be computed as the square root of the sum of all squared output noise voltage contributors. Equation 5 shows the general form for the output noise voltage using the terms shown in Figure 10.

(5)

$$E_O = \sqrt{\left(E_{NI}^2 + (I_{BN}R_S)^2 + 4kTR_S\right)NG^2 + (I_{BI}R_F)^2 + 4kTR_F}NG$$

Dividing this expression by the noise gain ($NG = (1 + R_F/R_G)$) will give the equivalent input-referred spot noise voltage at the noninverting input, as shown in Equation 6.

(6)

$$E_N = \sqrt{E_{NI}^2 + (I_{BN}R_S)^2 + 4kTR_S + \left(\frac{I_{BI}R_F}{NG}\right)^2 + \frac{4kTR_F}{NG}}$$

Evaluating these two equations for the OPA691 circuit and component values (see Figure 1) will give a total output spot noise voltage of 8.0nV/√Hz and a total equivalent input spot noise voltage of 4.0nV/√Hz. This total input-referred spot noise voltage is higher than the 1.7nV/√Hz specification for the op amp voltage noise alone. This reflects the noise added to the output by the inverting current noise times the feedback resistor. If the feedback resistor is reduced in high gain configurations (as suggested previously), the total input-referred voltage noise given by Equation 5 will approach just the 1.7nV/√Hz of the op amp itself. For example, going to a gain of +10 using $R_F = 180\Omega$ will give a total input-referred noise of 2.1nV/√Hz.

DC ACCURACY AND OFFSET CONTROL

A current feedback op amp like the OPA691 provides exceptional bandwidth in high gains, giving fast pulse settling but only moderate DC accuracy. The Typical Specifications show an input offset voltage comparable to high-speed voltage feedback amplifiers. However, the two input bias currents are somewhat higher and are unmatched. Whereas bias current cancellation techniques are very effective with most voltage feedback op amps, they do not generally reduce the output DC offset for wideband current feedback op amps. Since the two input bias currents are unrelated in both magnitude and polarity, matching the source impedance looking out of each input to reduce their error contribution to the output is ineffective. Evaluating the configuration of Figure 1, using worst-case +25°C input offset voltage and the two input bias currents, gives a worst-case output offset range equal to:

$$\begin{aligned} & \pm (NG \cdot V_{OS(MAX)}) + (I_{BN} \cdot R_S/2 \cdot NG) \pm (I_{BI} \cdot R_F) \\ & \text{where } NG = \text{noninverting signal gain} \\ & = \pm (2 \cdot 2.5\text{mV}) + (35\mu\text{A} \cdot 25\Omega \cdot 2) \pm (402\Omega \cdot 25\mu\text{A}) \\ & = \pm 5\text{mV} + 1.75\text{mV} \pm 10.05\text{mV} \\ & = -13.3\text{mV} \rightarrow +16.8\text{mV} \end{aligned}$$

A fine-scale, output offset null, or DC operating point adjustment, is sometimes required. Numerous techniques are available for introducing DC offset control into an op amp circuit. Most simple adjustment techniques do not correct for temperature drift. It is possible to combine a lower speed, precision op amp with the OPA691 to get the DC accuracy of the precision op amp along with the signal bandwidth of the OPA691. See Figure 11 for a noninverting $G = +10$ circuit that holds an output offset voltage less than $\pm 7.5\text{mV}$ over-temperature with $> 150\text{MHz}$ signal bandwidth.

This DC-coupled circuit provides very high signal bandwidth using the OPA691. At lower frequencies, the output voltage is attenuated by the signal gain and compared to the original

input voltage at the inputs of the OPA237 (this is a low-cost, precision voltage feedback op amp with 1.5MHz gain bandwidth product). If these two don't agree (due to DC offsets introduced by the OPA691), the OPA237 sums in a correction current through the 2.86kΩ inverting summing path. Several design considerations will allow this circuit to be optimized. First, the feedback to the OPA237's noninverting input must be precisely matched to the high-speed signal gain. Making the 2kΩ resistor to ground an adjustable resistor would allow the low and high frequency gains to be precisely matched. Secondly, the crossover frequency region where the OPA237 passes control to the OPA691 must occur with exceptional phase linearity. These two issues reduce to designing for pole/zero cancellation in the overall transfer function. Using the 2.86kΩ resistor will nominally satisfy this requirement for the circuit in Figure 11. Perfect cancellation over process and temperature is not possible. This initial resistor setting and precise gain matching, however, will minimize long-term pulse settling tails.

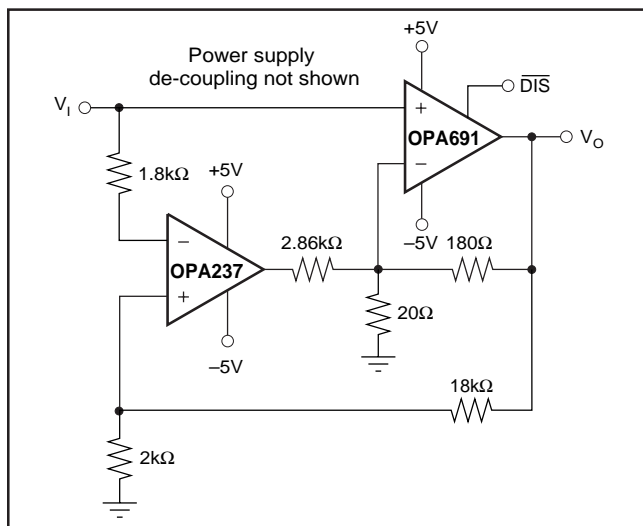

FIGURE 11. Wideband, DC Connected Composite Circuit.

DISABLE OPERATION

The OPA691 provides an optional disable feature that may be used to reduce system power. If the $\overline{\text{DIS}}$ control pin is left unconnected, the OPA691 will operate normally. To disable, the control pin must be asserted LOW. Figure 12 shows a simplified internal circuit for the disable control feature.

In normal operation, base current to Q1 is provided through the 110kΩ resistor while the emitter current through the 15kΩ resistor sets up a voltage drop that is inadequate to turn on the two diodes in Q1's emitter. As $V_{\overline{\text{DIS}}}$ is pulled LOW, additional current is pulled through the 15kΩ resistor eventually turning on these two diodes ($\approx 75\mu\text{A}$). At this point, any further current pulled out of $V_{\overline{\text{DIS}}}$ goes through those diodes holding the emitter-base voltage of Q1 at approximately 0V. This shuts off the collector current out of Q1, turning the amplifier off. The supply current in the disable mode are only those required to operate the circuit of Figure 12. Additional circuitry ensures that turn-on time occurs faster than turn-off time (make-before-break).

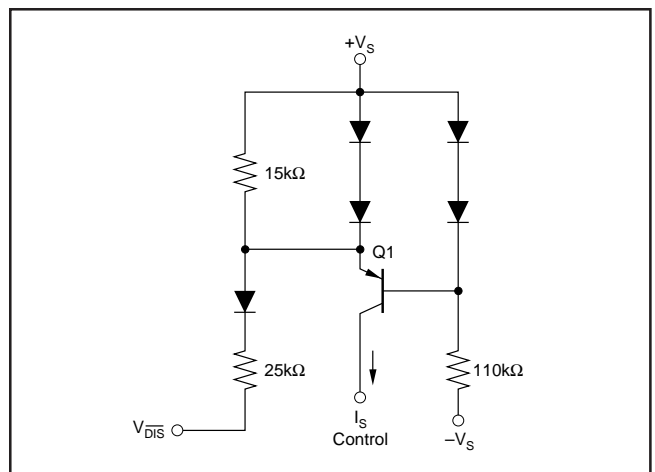

FIGURE 12. Simplified Disable Control Circuit.

When disabled, the output and input nodes go to a high impedance state. If the OPA691 is operating in a gain of +1, this will show a very high impedance ($4\text{pF} \parallel 1\text{M}\Omega$) at the output and exceptional signal isolation. If operating at a gain greater than +1, the total feedback network resistance ($R_F + R_G$) will appear as the impedance looking back into the output, but the circuit will still show very high forward and reverse isolation. If configured as an inverting amplifier, the input and output will be connected through the feedback network resistance ($R_F + R_G$) giving relatively poor input-to-output isolation.

One key parameter in disable operation is the output glitch when switching in and out of the disabled mode. Figure 13 shows these glitches for the circuit of Figure 1 with the input signal set to 0V. The glitch waveform at the output pin is plotted along with the $\overline{\text{DIS}}$ pin voltage.

The transition edge rate (dV/dT) of the $\overline{\text{DIS}}$ control line will influence this glitch. For the plot of Figure 12, the edge rate was reduced until no further reduction in glitch amplitude was observed. This approximately 1V/ns maximum slew rate may be achieved by adding a simple RC filter into the $V_{\overline{\text{DIS}}}$ pin from a higher speed logic line. If extremely fast transition logic is used, a 2kΩ series resistor between the logic gate and the $\overline{\text{DIS}}$ input pin will provide adequate bandlimiting using just the parasitic input capacitance on the $\overline{\text{DIS}}$ pin while still ensuring an adequate logic level swing.

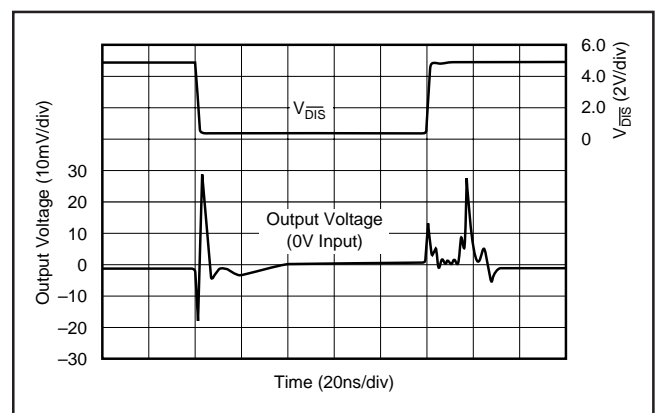

FIGURE 13. Disable/Enable Glitch.

THERMAL ANALYSIS

Due to the high output power capability of the OPA691, heatsinking or forced airflow may be required under extreme operating conditions. Maximum desired junction temperature will set the maximum allowed internal power dissipation, as described below. In no case should the maximum junction temperature be allowed to exceed 175°C.

Operating junction temperature (T_J) is given by $T_A + P_D \cdot \theta_{JA}$. The total internal power dissipation (P_D) is the sum of quiescent power (P_{DQ}) and additional power dissipated in the output stage (P_{DL}) to deliver load power. Quiescent power is simply the specified no-load supply current times the total supply voltage across the part. P_{DL} will depend on the required output signal and load but would, for a grounded resistive load, be at a maximum when the output is fixed at a voltage equal to 1/2 either supply voltage (for equal bipolar supplies). Under this condition $P_{DL} = V_S^2 / (4 \cdot R_L)$ where R_L includes feedback network loading.

Note that it is the power in the output stage and not in the load that determines internal power dissipation.

As a worst-case example, compute the maximum T_J using an OPA691IDBV (SOT23-6 package) in the circuit of Figure 1 operating at the maximum specified ambient temperature of +85°C and driving a grounded 20Ω load to +2.5V DC:

$$P_D = 10V \cdot 5.7mA + 5^2 / (4 \cdot (20\Omega \parallel 804\Omega)) = 377mW$$

$$\text{Maximum } T_J = +85^\circ\text{C} + (0.377W \cdot (150^\circ\text{C/W})) = 141.5^\circ\text{C}$$

Although this is still well below the specified maximum junction temperature, system reliability considerations may require lower junction temperatures. Remember, this is a worst-case internal power dissipation—use your actual signal and load to compute P_{DL} . The highest possible internal dissipation will occur if the load requires current to be forced into the output for positive output voltages or sourced from the output for negative output voltages. This puts a high current through a large internal voltage drop in the output transistors. The “Output Voltage and Current Limitations” plot shown in the Typical Characteristics includes a boundary for 1W maximum internal power dissipation under these conditions.

BOARD LAYOUT GUIDELINES

Achieving optimum performance with a high-frequency amplifier like the OPA691 requires careful attention to board layout parasitics and external component types. Recommendations that will optimize performance include:

a) Minimize parasitic capacitance to any AC ground for all of the signal I/O pins. Parasitic capacitance on the output and inverting input pins can cause instability: on the noninverting input, it can react with the source impedance to cause unintentional bandlimiting. To reduce unwanted capacitance, a window around the signal I/O pins should be opened in all of the ground and power planes around those pins. Otherwise, ground and power planes should be unbroken elsewhere on the board.

b) Minimize the distance (< 0.25") from the power-supply pins to high-frequency 0.1μF decoupling capacitors. At the device pins, the ground and power plane layout should not be in close proximity to the signal I/O pins. Avoid narrow power and ground traces to minimize inductance between the pins and the decoupling capacitors. The power-supply connections (on pins 4 and 7) should always be decoupled with these capacitors. An optional supply decoupling capacitor across the two power supplies (for bipolar operation) will improve 2nd-harmonic distortion performance. Larger (2.2μF to 6.8μF) decoupling capacitors, effective at lower frequencies, should also be used on the main supply pins. These may be placed somewhat farther from the device and may be shared among several devices in the same area of the PC board.

c) Careful selection and placement of external components will preserve the high-frequency performance of the OPA691. Resistors should be a very low reactance type. Surface-mount resistors work best and allow a tighter overall layout. Metal-film and carbon composition, axially-leaded resistors can also provide good high-frequency performance. Again, keep their leads and PC board trace length as short as possible. Never use wirewound type resistors in a high-frequency application. Since the output pin and inverting input pin are the most sensitive to parasitic capacitance, always position the feedback and series output resistor, if any, as close as possible to the output pin. Other network components, such as noninverting input termination resistors, should also be placed close to the package. Where double-side component mounting is allowed, place the feedback resistor directly under the package on the other side of the board between the output and inverting input pins. The frequency response is primarily determined by the feedback resistor value as described previously. Increasing its value will reduce the bandwidth, while decreasing it will give a more peaked frequency response. The 402Ω feedback resistor used in the Electrical Characteristic tables at a gain of +2 on ±5V supplies is a good starting point for design. Note that a 453Ω feedback resistor, rather than a direct short, is recommended for the unity-gain follower application. A current feedback op amp requires a feedback resistor even in the unity-gain follower configuration to control stability.

d) Connections to other wideband devices on the board may be made with short, direct traces or through onboard transmission lines. For short connections, consider the trace and the input to the next device as a lumped capacitive load. Relatively wide traces (50mils to 100mils) should be used, preferably with ground and power planes opened up around them. Estimate the total capacitive load and set R_S from the plot of recommended R_S versus Capacitive Load. Low parasitic capacitive loads (< 5pF) may not need an R_S since the OPA691 is nominally compensated to operate with a 2pF parasitic load. If a long trace is required, and the 6dB signal loss intrinsic to a doubly-terminated transmission line is acceptable, implement a matched impedance transmission line using microstrip or stripline techniques (consult an ECL

design handbook for microstrip and stripline layout techniques). A 50Ω environment is normally not necessary on board, and in fact, a higher impedance environment will improve distortion, as shown in the Distortion versus Load plots. With a characteristic board trace impedance defined based on board material and trace dimensions, a matching series resistor into the trace from the output of the OPA691 is used as well as a terminating shunt resistor at the input of the destination device. Remember also that the terminating impedance will be the parallel combination of the shunt resistor and the input impedance of the destination device: this total effective impedance should be set to match the trace impedance. The high output voltage and current capability of the OPA691 allows multiple destination devices to be handled as separate transmission lines, each with their own series and shunt terminations. If the 6dB attenuation of a doubly-terminated transmission line is unacceptable, a long trace can be series-terminated at the source end only. Treat the trace as a capacitive load in this case and set the series resistor value as shown in the plot of R_S versus Capacitive Load. This will not preserve signal integrity as well as a doubly-terminated line. If the input impedance of the destination device is low, there will be some signal attenuation due to the voltage divider formed by the series output into the terminating impedance.

e) Socketing a high-speed part like the OPA691 is not recommended. The additional lead length and pin-to-pin capacitance introduced by the socket can create an extremely troublesome parasitic network which can make it almost impossible to achieve a smooth, stable frequency response. Best results are obtained by soldering the OPA691 onto the board.

INPUT AND ESD PROTECTION

The OPA691 is built using a very high speed complementary bipolar process. The internal junction breakdown voltages are relatively low for these very small geometry devices. These breakdowns are reflected in the Absolute Maximum Ratings table. All device pins have limited ESD protection using internal diodes to the power supplies, as shown in Figure 14.

These diodes provide moderate protection to input overdrive voltages above the supplies as well. The protection diodes can typically support 30mA continuous current. Where higher currents are possible (e.g., in systems with $\pm 15V$ supply parts driving into the OPA691), current-limiting series resistors should be added into the two inputs. Keep these resistor values as low as possible since high values degrade both noise performance and frequency response.

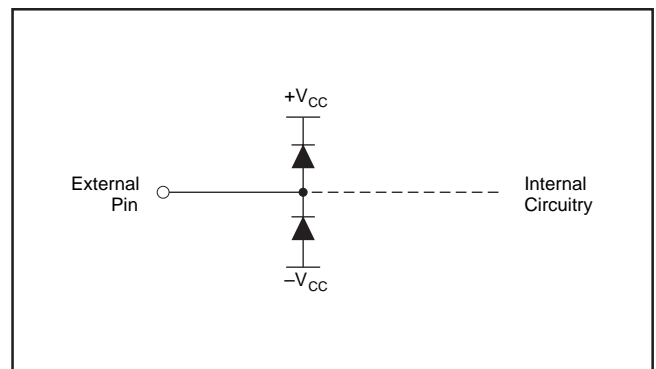

FIGURE 14. Internal ESD Protection.

Revision History

DATE	REVISION	PAGE	SECTION	DESCRIPTION
7/08	D	2	Abs Max Ratings	Changed Storage Temperature Range from -40°C to $+125^{\circ}\text{C}$ to -65°C to $+125^{\circ}\text{C}$.
		3, 4	Electrical Characteristics, Power Supply	Added minimum supply voltage.
2/07	C	8	Typical Characteristics	Changed <i>Closed-Loop Output Impedance vs Frequency</i> plot.

NOTE: Page numbers for previous revisions may differ from page numbers in the current version.

PACKAGING INFORMATION

Orderable Device	Status (1)	Package Type	Package Drawing	Pins	Package Qty	Eco Plan (2)	Lead/Ball Finish (6)	MSL Peak Temp (3)	Op Temp (°C)	Device Marking (4/5)	Samples
OPA691ID	ACTIVE	SOIC	D	8	75	Green (RoHS & no Sb/Br)	CU NIPDAU	Level-2-260C-1 YEAR	-40 to 85	OPA 691	Samples
OPA691IDBVR	ACTIVE	SOT-23	DBV	6	3000	Green (RoHS & no Sb/Br)	CU NIPDAU	Level-2-260C-1 YEAR	-40 to 85	OAFI	Samples
OPA691IDBVRG4	ACTIVE	SOT-23	DBV	6	3000	Green (RoHS & no Sb/Br)	CU NIPDAU	Level-2-260C-1 YEAR	-40 to 85	OAFI	Samples
OPA691IDBVT	ACTIVE	SOT-23	DBV	6	250	Green (RoHS & no Sb/Br)	CU NIPDAU	Level-2-260C-1 YEAR	-40 to 85	OAFI	Samples
OPA691IDBVTG4	ACTIVE	SOT-23	DBV	6	250	Green (RoHS & no Sb/Br)	CU NIPDAU	Level-2-260C-1 YEAR	-40 to 85	OAFI	Samples
OPA691IDG4	ACTIVE	SOIC	D	8	75	Green (RoHS & no Sb/Br)	CU NIPDAU	Level-2-260C-1 YEAR	-40 to 85	OPA 691	Samples
OPA691IDR	ACTIVE	SOIC	D	8	2500	Green (RoHS & no Sb/Br)	CU NIPDAU	Level-2-260C-1 YEAR	-40 to 85	OPA 691	Samples

(1) The marketing status values are defined as follows:

ACTIVE: Product device recommended for new designs.

LIFEBUY: TI has announced that the device will be discontinued, and a lifetime-buy period is in effect.

NRND: Not recommended for new designs. Device is in production to support existing customers, but TI does not recommend using this part in a new design.

PREVIEW: Device has been announced but is not in production. Samples may or may not be available.

OBSELETE: TI has discontinued the production of the device.

(2) **RoHS:** TI defines "RoHS" to mean semiconductor products that are compliant with the current EU RoHS requirements for all 10 RoHS substances, including the requirement that RoHS substance do not exceed 0.1% by weight in homogeneous materials. Where designed to be soldered at high temperatures, "RoHS" products are suitable for use in specified lead-free processes. TI may reference these types of products as "Pb-Free".

RoHS Exempt: TI defines "RoHS Exempt" to mean products that contain lead but are compliant with EU RoHS pursuant to a specific EU RoHS exemption.

Green: TI defines "Green" to mean the content of Chlorine (Cl) and Bromine (Br) based flame retardants meet JS709B low halogen requirements of <=100ppm threshold. Antimony trioxide based flame retardants must also meet the <=1000ppm threshold requirement.

(3) MSL, Peak Temp. - The Moisture Sensitivity Level rating according to the JEDEC industry standard classifications, and peak solder temperature.

(4) There may be additional marking, which relates to the logo, the lot trace code information, or the environmental category on the device.

(5) Multiple Device Markings will be inside parentheses. Only one Device Marking contained in parentheses and separated by a "-" will appear on a device. If a line is indented then it is a continuation of the previous line and the two combined represent the entire Device Marking for that device.

⁽⁶⁾ Lead/Ball Finish - Orderable Devices may have multiple material finish options. Finish options are separated by a vertical ruled line. Lead/Ball Finish values may wrap to two lines if the finish value exceeds the maximum column width.

Important Information and Disclaimer: The information provided on this page represents TI's knowledge and belief as of the date that it is provided. TI bases its knowledge and belief on information provided by third parties, and makes no representation or warranty as to the accuracy of such information. Efforts are underway to better integrate information from third parties. TI has taken and continues to take reasonable steps to provide representative and accurate information but may not have conducted destructive testing or chemical analysis on incoming materials and chemicals. TI and TI suppliers consider certain information to be proprietary, and thus CAS numbers and other limited information may not be available for release.

In no event shall TI's liability arising out of such information exceed the total purchase price of the TI part(s) at issue in this document sold by TI to Customer on an annual basis.

TAPE AND REEL INFORMATION



QUADRANT ASSIGNMENTS FOR PIN 1 ORIENTATION IN TAPE



*All dimensions are nominal

Device	Package Type	Package Drawing	Pins	SPQ	Reel Diameter (mm)	Reel Width W1 (mm)	A0 (mm)	B0 (mm)	K0 (mm)	P1 (mm)	W (mm)	Pin1 Quadrant
OPA691IDR	SOIC	D	8	2500	330.0	12.4	6.4	5.2	2.1	8.0	12.0	Q1

TAPE AND REEL BOX DIMENSIONS

*All dimensions are nominal

Device	Package Type	Package Drawing	Pins	SPQ	Length (mm)	Width (mm)	Height (mm)
OPA691IDR	SOIC	D	8	2500	367.0	367.0	35.0

DBV0006A



PACKAGE OUTLINE

SOT-23 - 1.45 mm max height

SMALL OUTLINE TRANSISTOR



4214840/B 03/2018

NOTES:

1. All linear dimensions are in millimeters. Any dimensions in parenthesis are for reference only. Dimensioning and tolerancing per ASME Y14.5M.
2. This drawing is subject to change without notice.
3. Body dimensions do not include mold flash or protrusion. Mold flash and protrusion shall not exceed 0.15 per side.
4. Leads 1,2,3 may be wider than leads 4,5,6 for package orientation.
5. Reference JEDEC MO-178.

EXAMPLE BOARD LAYOUT

DBV0006A

SOT-23 - 1.45 mm max height

SMALL OUTLINE TRANSISTOR



LAND PATTERN EXAMPLE
EXPOSED METAL SHOWN
SCALE:15X



SOLDER MASK DETAILS

4214840/B 03/2018

NOTES: (continued)

- 6. Publication IPC-7351 may have alternate designs.
- 7. Solder mask tolerances between and around signal pads can vary based on board fabrication site.

EXAMPLE STENCIL DESIGN

DBV0006A

SOT-23 - 1.45 mm max height

SMALL OUTLINE TRANSISTOR



SOLDER PASTE EXAMPLE
BASED ON 0.125 mm THICK STENCIL
SCALE:15X

4214840/B 03/2018

NOTES: (continued)

8. Laser cutting apertures with trapezoidal walls and rounded corners may offer better paste release. IPC-7525 may have alternate design recommendations.
9. Board assembly site may have different recommendations for stencil design.



D0008A

PACKAGE OUTLINE

SOIC - 1.75 mm max height

SMALL OUTLINE INTEGRATED CIRCUIT



4214825/C 02/2019

NOTES:

1. Linear dimensions are in inches [millimeters]. Dimensions in parenthesis are for reference only. Controlling dimensions are in inches. Dimensioning and tolerancing per ASME Y14.5M.
2. This drawing is subject to change without notice.
3. This dimension does not include mold flash, protrusions, or gate burrs. Mold flash, protrusions, or gate burrs shall not exceed $.006$ [0.15] per side.
4. This dimension does not include interlead flash.
5. Reference JEDEC registration MS-012, variation AA.

EXAMPLE BOARD LAYOUT

D0008A

SOIC - 1.75 mm max height

SMALL OUTLINE INTEGRATED CIRCUIT



LAND PATTERN EXAMPLE
EXPOSED METAL SHOWN
SCALE:8X



SOLDER MASK DETAILS

4214825/C 02/2019

NOTES: (continued)

- 6. Publication IPC-7351 may have alternate designs.
- 7. Solder mask tolerances between and around signal pads can vary based on board fabrication site.

EXAMPLE STENCIL DESIGN

D0008A

SOIC - 1.75 mm max height

SMALL OUTLINE INTEGRATED CIRCUIT



SOLDER PASTE EXAMPLE
BASED ON .005 INCH [0.125 MM] THICK STENCIL
SCALE:8X

4214825/C 02/2019

NOTES: (continued)

8. Laser cutting apertures with trapezoidal walls and rounded corners may offer better paste release. IPC-7525 may have alternate design recommendations.
9. Board assembly site may have different recommendations for stencil design.

IMPORTANT NOTICE AND DISCLAIMER

TI PROVIDES TECHNICAL AND RELIABILITY DATA (INCLUDING DATASHEETS), DESIGN RESOURCES (INCLUDING REFERENCE DESIGNS), APPLICATION OR OTHER DESIGN ADVICE, WEB TOOLS, SAFETY INFORMATION, AND OTHER RESOURCES "AS IS" AND WITH ALL FAULTS, AND DISCLAIMS ALL WARRANTIES, EXPRESS AND IMPLIED, INCLUDING WITHOUT LIMITATION ANY IMPLIED WARRANTIES OF MERCHANTABILITY, FITNESS FOR A PARTICULAR PURPOSE OR NON-INFRINGEMENT OF THIRD PARTY INTELLECTUAL PROPERTY RIGHTS.

These resources are intended for skilled developers designing with TI products. You are solely responsible for (1) selecting the appropriate TI products for your application, (2) designing, validating and testing your application, and (3) ensuring your application meets applicable standards, and any other safety, security, or other requirements. These resources are subject to change without notice. TI grants you permission to use these resources only for development of an application that uses the TI products described in the resource. Other reproduction and display of these resources is prohibited. No license is granted to any other TI intellectual property right or to any third party intellectual property right. TI disclaims responsibility for, and you will fully indemnify TI and its representatives against, any claims, damages, costs, losses, and liabilities arising out of your use of these resources.

TI's products are provided subject to TI's Terms of Sale (www.ti.com/legal/termsofsale.html) or other applicable terms available either on ti.com or provided in conjunction with such TI products. TI's provision of these resources does not expand or otherwise alter TI's applicable warranties or warranty disclaimers for TI products.

Mailing Address: Texas Instruments, Post Office Box 655303, Dallas, Texas 75265
Copyright © 2019, Texas Instruments Incorporated

Looking for pricing, stock, or lifecycle information?

Click below to explore more details on WIN SOURCE:

 [View OPA691IDBVT on WIN SOURCE](#)

 [Texas Instruments](#) Information

Optimize Your Supply Chain with WIN SOURCE Solutions

-  Global Sourcing Solution
-  Obsolete Management
-  Cost Control Management
-  Shortage Management
-  Alternative Solution
-  Excess Inventory Management