

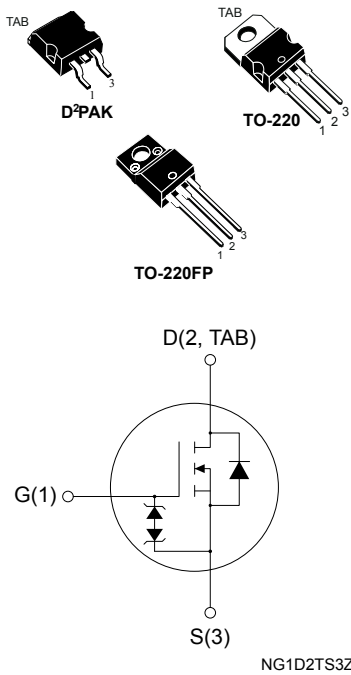

THE DATASHEET OF P11NK40ZFP



N-channel 400 V, 0.47 Ω typ., 9 A SuperMESH Power MOSFETs in a D²PAK, TO-220 and TO-220FP packages



Features

Order code	V_{DS}	$R_{DS(on)}$ max.	I_D	Package
STB11NK40ZT4	400 V	0.55 Ω	9 A	D ² PAK
STP11NK40Z				TO-220
STP11NK40ZFP				TO-220FP

- 100% avalanche tested
- Gate charge minimized
- Very low intrinsic capacitance
- Zener-protected

Applications

- Switching applications

Description

These high-voltage devices are Zener-protected N-channel Power MOSFETs developed using the SuperMESH™ technology by STMicroelectronics, an optimization of the well-established PowerMESH™. In addition to a significant reduction in on-resistance, these devices are designed to ensure a high level of dv/dt capability for the most demanding applications.

Product status link

[STB11NK40ZT4](#)
[STP11NK40Z](#)
[STP11NK40ZFP](#)

1 Electrical ratings

Table 1. Absolute maximum ratings

Symbol	Parameter	Value		Unit
		D ² PAK, TO-220	TO-220FP	
V _{DS}	Drain-source voltage	400		V
V _{GS}	Gate-source voltage	±30		V
I _D	Drain current (continuous) at T _C = 25 °C	9	9 ⁽¹⁾	A
I _D	Drain current (continuous) at T _C = 100 °C	5.67	5.67 ⁽¹⁾	A
I _{DM} ⁽²⁾	Drain current (pulsed)	36	36 ⁽¹⁾	A
P _{TOT}	Total dissipation at T _C = 25 °C	110	30	W
ESD	Gate-source human body model (C = 100 pF, R = 1.5 kΩ)	3.5		kV
dv/dt ⁽³⁾	Peak diode recovery voltage slope	4.5		V/ns
V _{ISO}	Insulation withstand voltage (RMS) from all three leads to external heat sink (t = 1 s; T _C = 25 °C)		2.5	kV
T _J	Operating junction temperature range	-55 to 150		°C
T _{stg}	Storage temperature range			

- Limited by maximum junction temperature.
- Pulse width limited by safe operating area.
- I_{SD} ≤ 9 A, di/dt ≤ 200 A/μs, V_{DD} = 80% V_{(BR)DSS}, T_J ≤ T_{JMAX}.

Table 2. Thermal data

Symbol	Parameter	Value			Unit
		D ² PAK	TO-220	TO-220FP	
R _{thj-case}	Thermal resistance junction-case	1.14		4.17	°C/W
R _{thj-amb}	Thermal resistance junction-ambient		62.5		°C/W
R _{thj-pcb} ⁽¹⁾	Thermal resistance junction-pcb	50			°C/W

- When mounted on 1inch² FR-4 board, 2 oz Cu.

Table 3. Avalanche characteristics

Symbol	Parameter	Value	Unit
I _{AR}	Avalanche current, repetitive or not-repetitive (pulse width limited by T _J Max)	9	A
E _{AS}	Single pulse avalanche energy (starting T _J = 25 °C, I _D = I _{AR} , V _{DD} = 50 V)	190	mJ

2 Electrical characteristics

($T_{CASE} = 25\text{ °C}$ unless otherwise specified)

Table 4. On/off states

Symbol	Parameter	Test condition	Min.	Typ.	Max.	Unit
$V_{(BR)DSS}$	Drain-source Breakdown voltage	$I_D = 1\text{ mA}$, $V_{GS} = 0\text{ V}$	400			V
I_{DSS}	Zero gate voltage drain current	$V_{GS} = 0\text{ V}$, $V_{DS} = 400\text{ V}$			1	μA
		$V_{GS} = 0\text{ V}$, $V_{DS} = 400\text{ V}$, $T_C = 125\text{ °C}^{(1)}$			50	μA
I_{GSS}	Gate body leakage current	$V_{DS} = 0\text{ V}$, $V_{GS} = \pm 20\text{ V}$			± 10	μA
$V_{GS(th)}$	Gate threshold voltage	$V_{DS} = V_{GS}$, $I_D = 100\text{ }\mu\text{A}$	3	3.75	4.5	V
$R_{DS(on)}$	Static drain-source on resistance	$V_{GS} = 10\text{ V}$, $I_D = 4.5\text{ A}$		0.47	0.55	Ω

1. Defined by design, not subject to production test.

Table 5. Dynamic

Symbol	Parameter	Test condition	Min.	Typ.	Max.	Unit
C_{iss}	Input capacitance	$V_{DS} = 25\text{ V}$, $f = 1\text{ MHz}$, $V_{GS} = 0\text{ V}$	-	930	-	μF
C_{oss}	Output capacitance			140		
C_{rss}	Reverse transfer capacitance			30		
$C_{oss\ eq.}^{(1)}$	Equivalent output capacitance	$V_{DS} = 0\text{ to }320\text{ V}$, $V_{GS} = 0\text{ V}$	-	78	-	μF
Q_g	Total gate charge	$V_{DD} = 320\text{ V}$, $I_D = 9\text{ A}$, $V_{GS} = 0\text{ to }10\text{ V}$ (see Figure 16. Test circuit for gate charge behavior)	-	32	-	nC
Q_{gs}	Gate-source charge			6		
Q_{gd}	Gate-drain charge			18.5		

1. $C_{oss\ eq.}$ is defined as a constant equivalent capacitance giving the same charging time as C_{oss} when V_{DS} increases from 0 to 80% V_{DSS} .

Table 6. Switching times

Symbol	Parameter	Test condition	Min.	Typ.	Max.	Unit
$t_{d(on)}$	Turn-on delay time	$V_{DD} = 200\text{ V}$, $I_D = 4.5\text{ A}$, $R_G = 4.7\text{ }\Omega$, $V_{GS} = 10\text{ V}$ (see Figure 15. Test circuit for resistive load switching times and Figure 20. Switching time waveform)	-	20	-	ns
t_r	Rise time			20		
$t_{d(off)}$	Turn-off delay time			40		
t_f	Fall time			18		
$t_{r(Voff)}$	Off-voltage rise time	$V_{DD} = 320\text{ V}$, $I_D = 9\text{ A}$, $R_G = 4.7\text{ }\Omega$, $V_{GS} = 10\text{ V}$ (see Figure 17. Test circuit for inductive load switching and diode recovery times)		15		
t_f	Fall time			17		
t_c	Cross-over time			30		

Table 7. Source drain diode

Symbol	Parameter	Test condition	Min.	Typ.	Max.	Unit
I_{SD}	Source-drain current		-		9	A
$I_{SDM}^{(1)}$	Source-drain current (pulsed)				36	
$V_{SD}^{(2)}$	Forward on voltage	$I_{SD} = 9\text{ A}, V_{GS} = 0\text{ V}$	-		1.6	V
t_{rr}	Reverse recovery time	$I_{SD} = 9\text{ A}, di/dt = 100\text{ A}/\mu\text{s}, V_{DD} = 45\text{ V}, T_j = 150\text{ }^\circ\text{C}$ (see Figure 17. Test circuit for inductive load switching and diode recovery times)	-	225		ns
Q_{rr}	Reverse recovery charge			1.6		μC
I_{RRM}	Reverse recovery current			14		A

1. Pulse width limited by safe operating area.
2. Pulsed: pulse duration = 300 μs , duty cycle 1.5%.

Table 8. Gate-source Zener diode

Symbol	Parameter	Test conditions	Min.	Typ.	Max.	Unit
$V_{(BR)GSO}$	Gate-source breakdown voltage	$I_{GS} = \pm 1\text{ mA}, I_D = 0\text{ A}$	± 30	-	-	V

The built-in back-to-back Zener diodes are specifically designed to enhance the ESD performance of the device. The Zener voltage facilitates efficient and cost-effective device integrity protection, thus eliminating the need for additional external componentry.

2.1 Electrical characteristics curves

Figure 1. Safe operating area for TO-220, D²PAK

Figure 2. Thermal impedance for TO-220, D²PAK

Figure 3. Safe operating area for TO-220FP

Figure 4. Thermal impedance for TO-220FP

Figure 5. Output characteristics

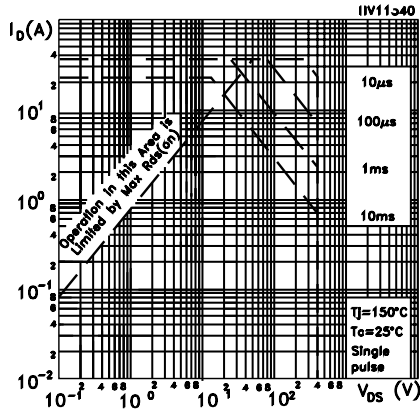
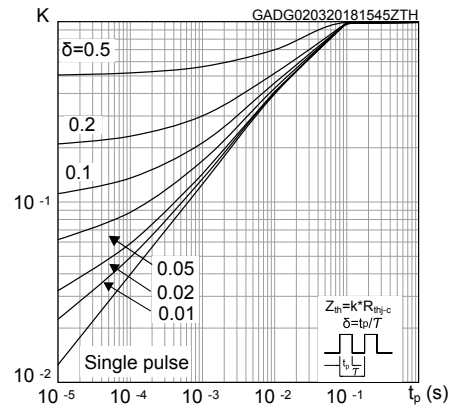
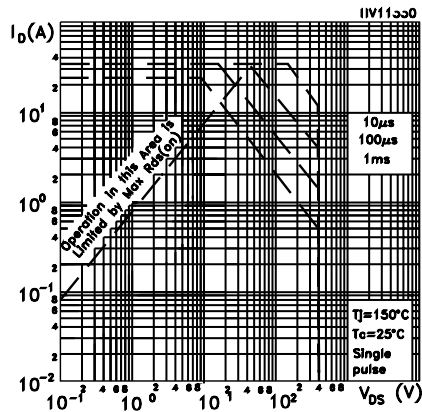
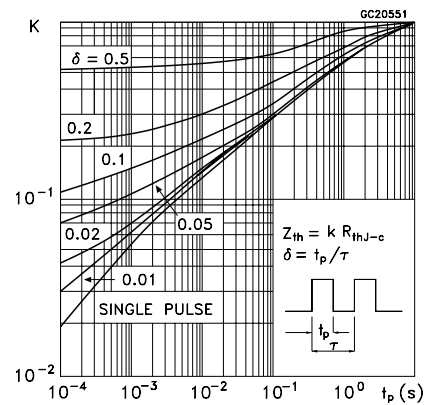
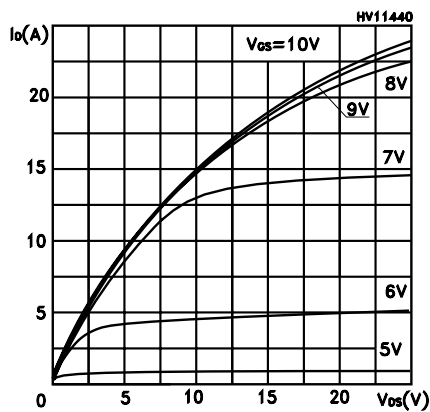
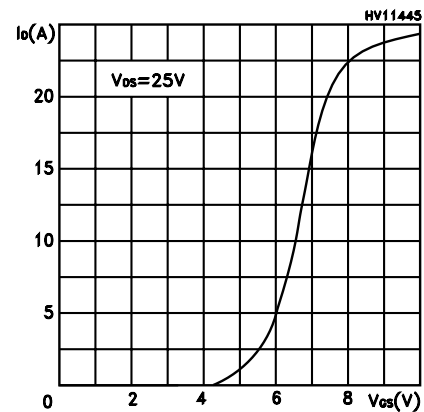
Figure 6. Transfer characteristics

Figure 7. Static drain-source on resistance

Figure 8. Gate charge vs gate-source voltage

Figure 9. Capacitance variations

Figure 10. Normalized gate threshold voltage vs temperature

Figure 11. Normalized on resistance vs temperature

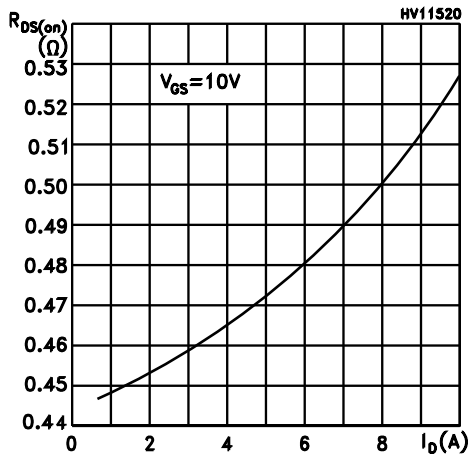
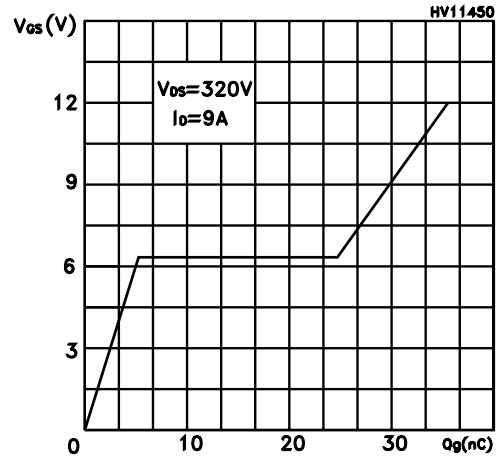
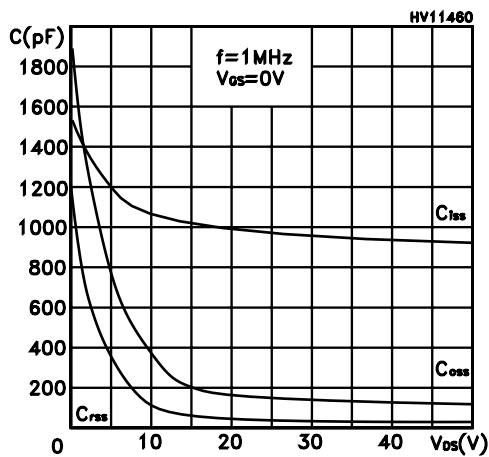
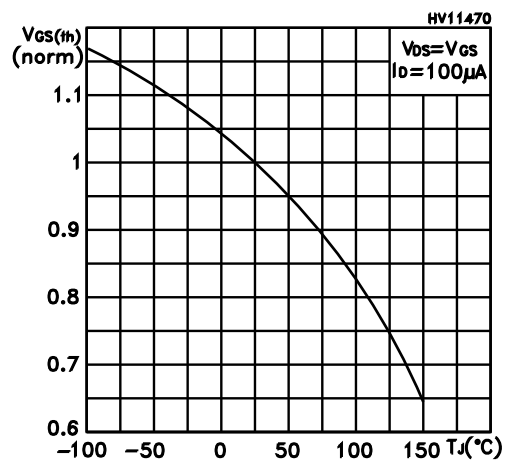
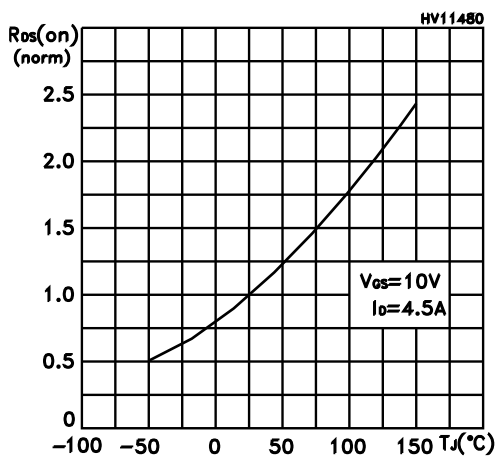
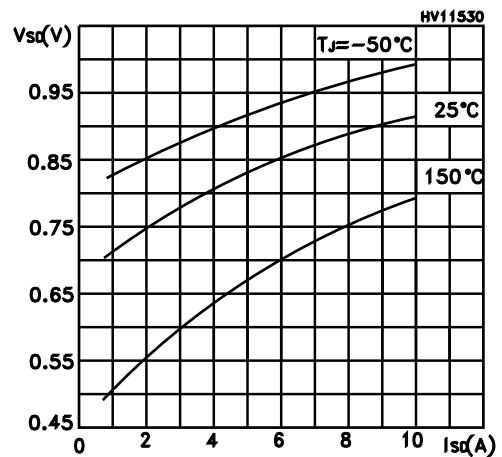
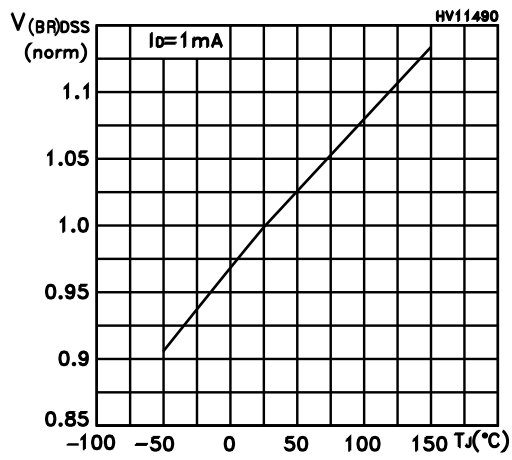
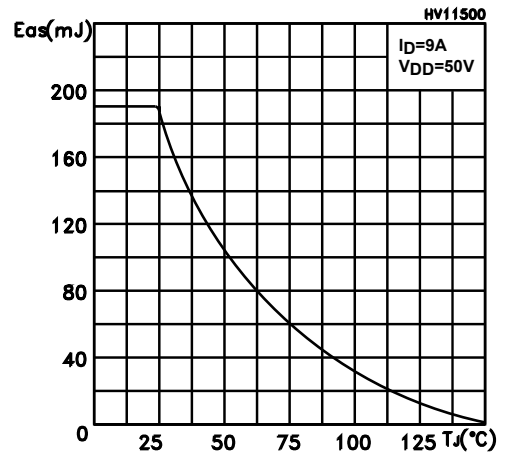
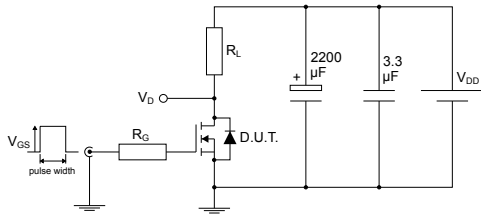
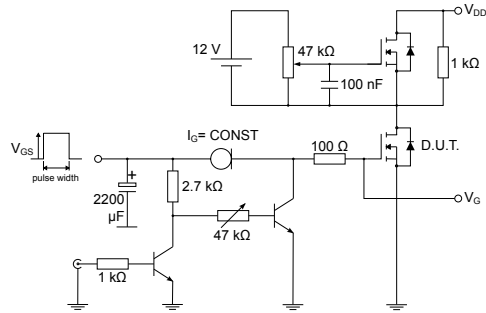
Figure 12. Source-drain diode forward characteristics

Figure 13. Normalized $V_{(BR)DSS}$ vs temperature

Figure 14. Maximum avalanche energy vs temperature

3 Test circuits

Figure 15. Test circuit for resistive load switching times

AM01468v1

Figure 16. Test circuit for gate charge behavior

AM01469v1

Figure 17. Test circuit for inductive load switching and diode recovery times



AM01470v1

Figure 18. Unclamped inductive load test circuit

AM01471v1

Figure 19. Unclamped inductive waveform

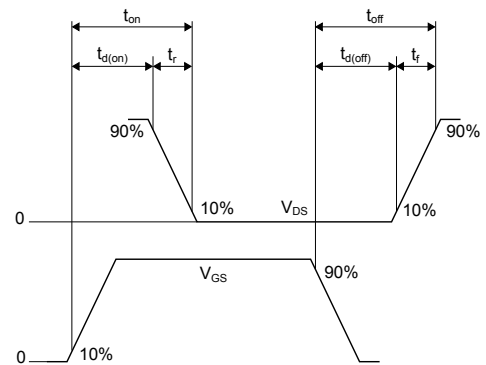
AM01472v1

Figure 20. Switching time waveform

AM01473v1

4 Package information

In order to meet environmental requirements, ST offers these devices in different grades of ECOPACK® packages, depending on their level of environmental compliance. ECOPACK® specifications, grade definitions and product status are available at: www.st.com. ECOPACK® is an ST trademark.

4.1 D²PAK (TO-263) type A package information

Figure 21. D²PAK (TO-263) type A package outline

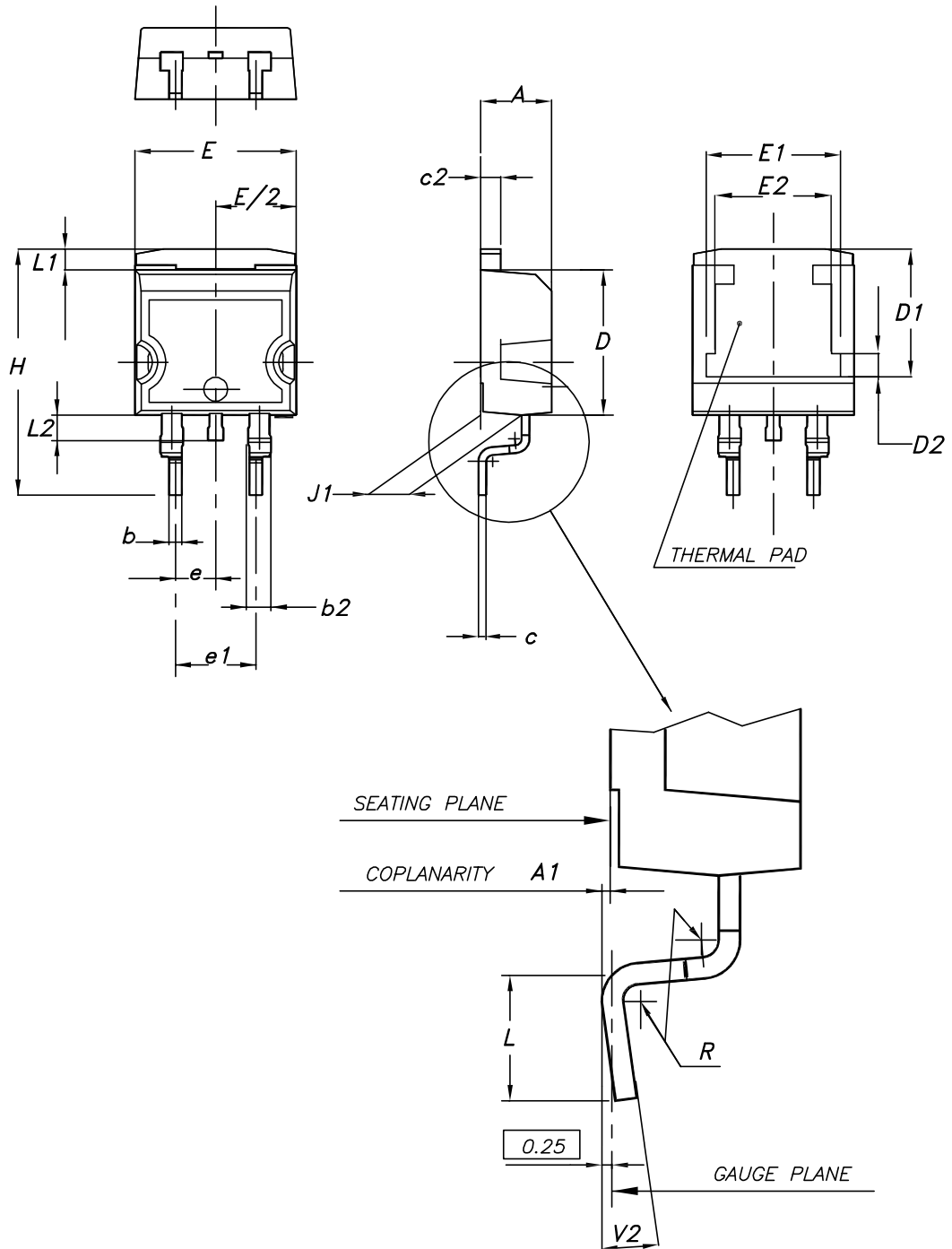

0079457_25

Table 9. D²PAK (TO-263) type A package mechanical data

Dim.	mm		
	Min.	Typ.	Max.
A	4.40		4.60
A1	0.03		0.23
b	0.70		0.93
b2	1.14		1.70
c	0.45		0.60
c2	1.23		1.36
D	8.95		9.35
D1	7.50	7.75	8.00
D2	1.10	1.30	1.50
E	10.00		10.40
E1	8.30	8.50	8.70
E2	6.85	7.05	7.25
e		2.54	
e1	4.88		5.28
H	15.00		15.85
J1	2.49		2.69
L	2.29		2.79
L1	1.27		1.40
L2	1.30		1.75
R		0.40	
V2	0°		8°

4.2 D²PAK (TO-263) type B package information

Figure 22. D²PAK (TO-263) type B package outline

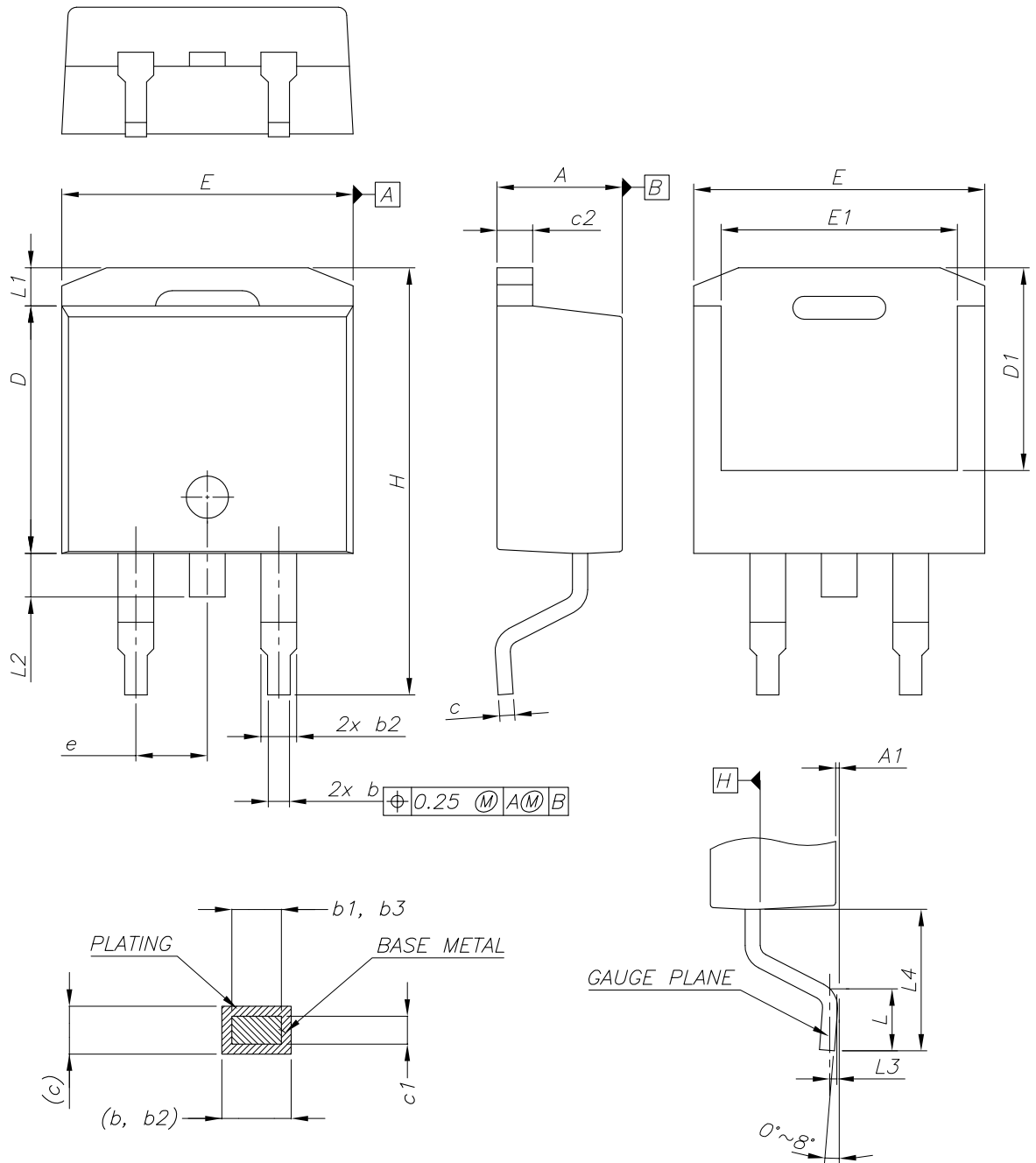

0079457_25_B

Table 10. D²PAK (TO-263) type B mechanical data

Dim.	mm		
	Min.	Typ.	Max.
A	4.36		4.56
A1	0		0.25
b	0.70		0.90
b1	0.51		0.89
b2	1.17		1.37
b3	1.36		1.46
c	0.38		0.694
c1	0.38		0.534
c2	1.19		1.34
D	8.60		9.00
D1	6.90		7.50
E	10.15		10.55
E1	8.10		8.70
e	2.54 BSC		
H	15.00		15.60
L	1.90		2.50
L1			1.65
L2			1.78
L3		0.25	
L4	4.78		5.28

Figure 23. D²PAK (TO-263) recommended footprint (dimensions are in mm)

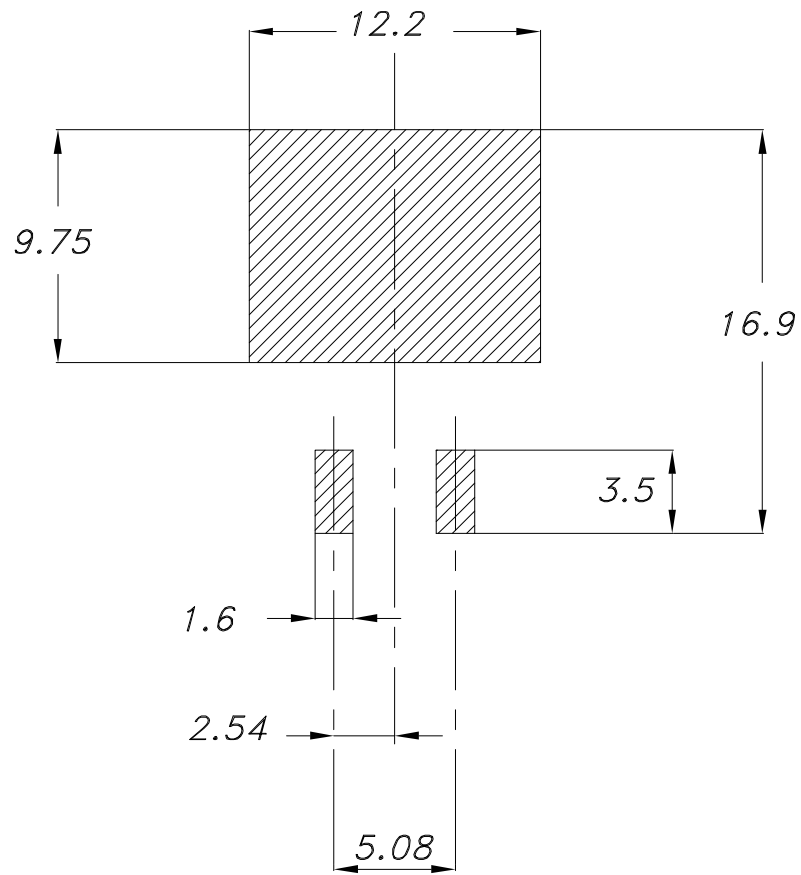

Footprint

4.3 D²PAK packing information

Figure 24. D²PAK tape outline

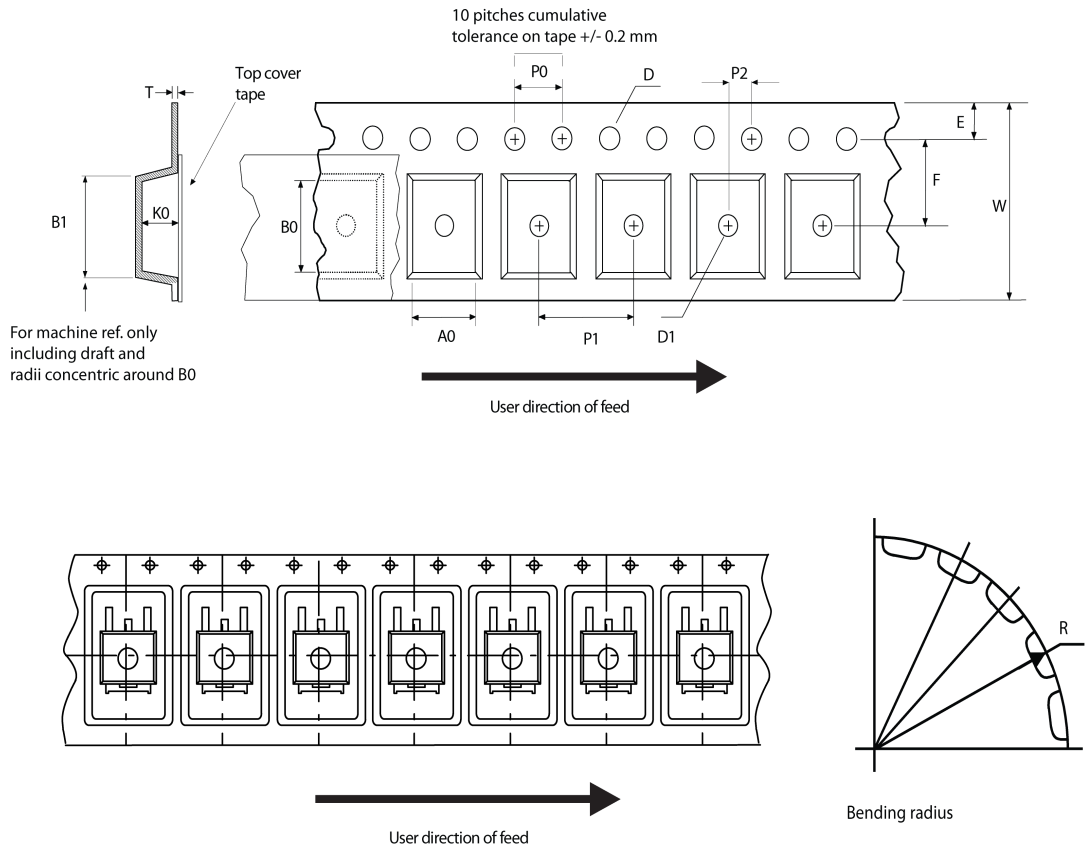

AM08852v1

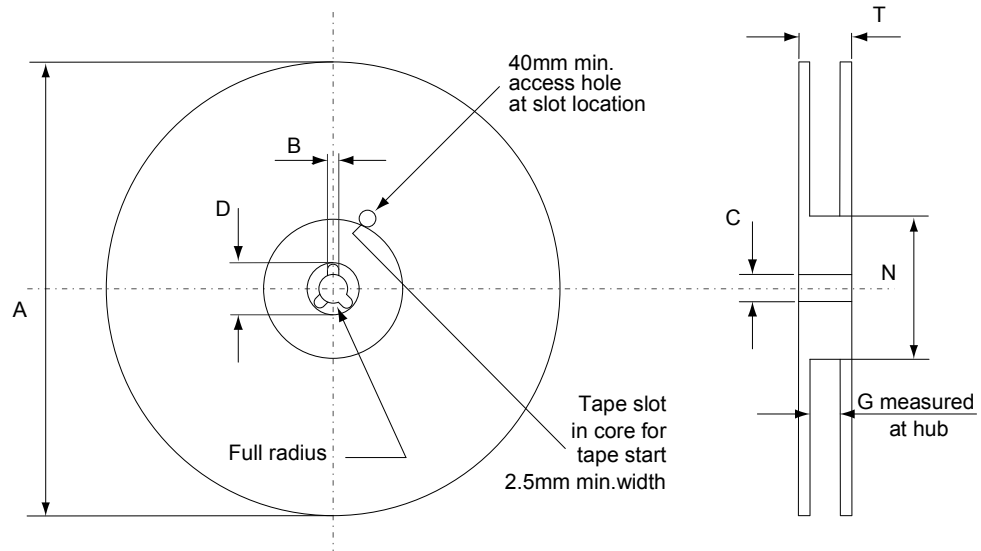
Figure 25. D²PAK reel outline

AM06038v1

Table 11. D²PAK tape and reel mechanical data

Tape			Reel		
Dim.	mm		Dim.	mm	
	Min.	Max.		Min.	Max.
A0	10.5	10.7	A		330
B0	15.7	15.9	B	1.5	
D	1.5	1.6	C	12.8	13.2
D1	1.59	1.61	D	20.2	
E	1.65	1.85	G	24.4	26.4
F	11.4	11.6	N	100	
K0	4.8	5.0	T		30.4
P0	3.9	4.1	Base quantity		
P1	11.9	12.1			
P2	1.9	2.1	Bulk quantity		
R	50				
T	0.25	0.35			
W	23.7	24.3			

4.4 D²PAK type B packing information

Figure 26. D²PAK type B tape outline

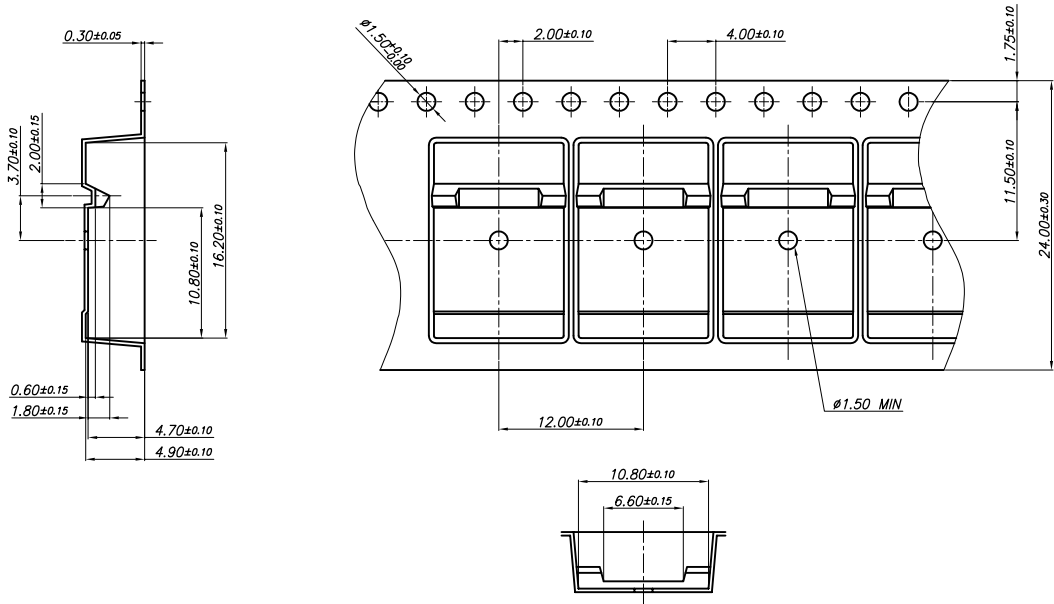
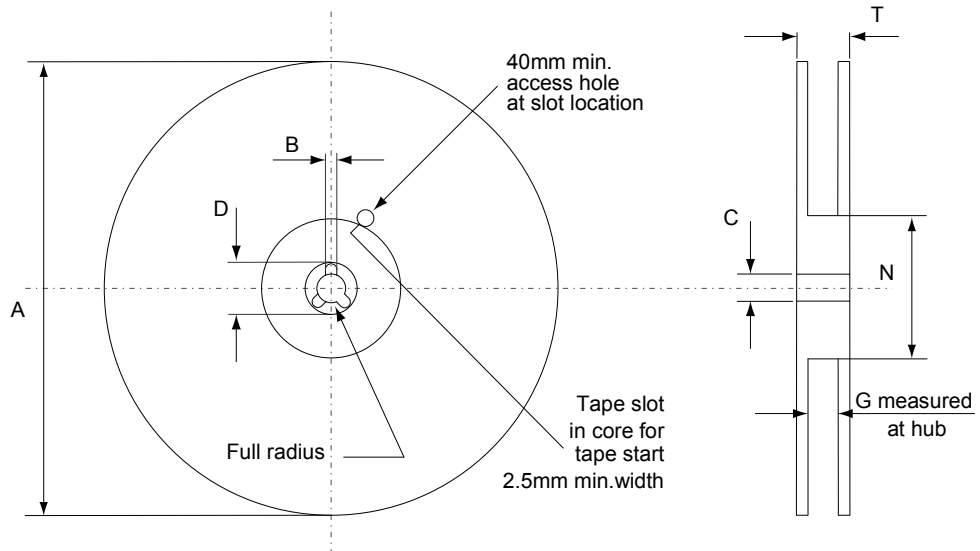

Figure 27. D²PAK type B reel outline



AM06038v1

Table 12. D²PAK type B reel mechanical data

Dim.	mm	
	Min.	Max.
A		330
B	1.5	
C	12.8	13.2
D	20.2	
G	24.4	26.4
N	100	
T		30.4

4.5 TO-220FP package information

Figure 28. TO-220FP package outline

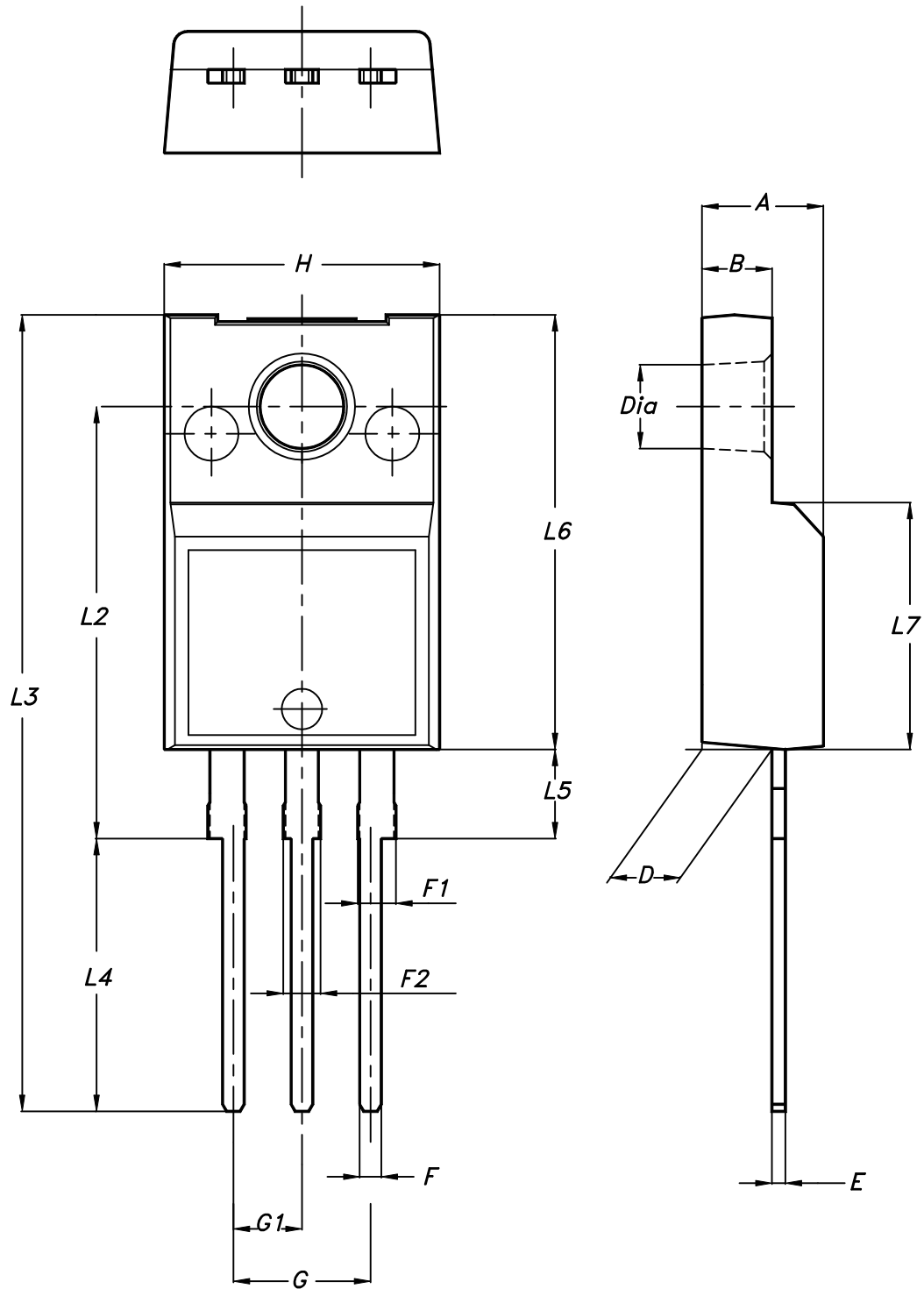

7012510_Rev_12_B

Table 13. TO-220FP package mechanical data

Dim.	mm		
	Min.	Typ.	Max.
A	4.4		4.6
B	2.5		2.7
D	2.5		2.75
E	0.45		0.7
F	0.75		1
F1	1.15		1.70
F2	1.15		1.70
G	4.95		5.2
G1	2.4		2.7
H	10		10.4
L2		16	
L3	28.6		30.6
L4	9.8		10.6
L5	2.9		3.6
L6	15.9		16.4
L7	9		9.3
Dia	3		3.2

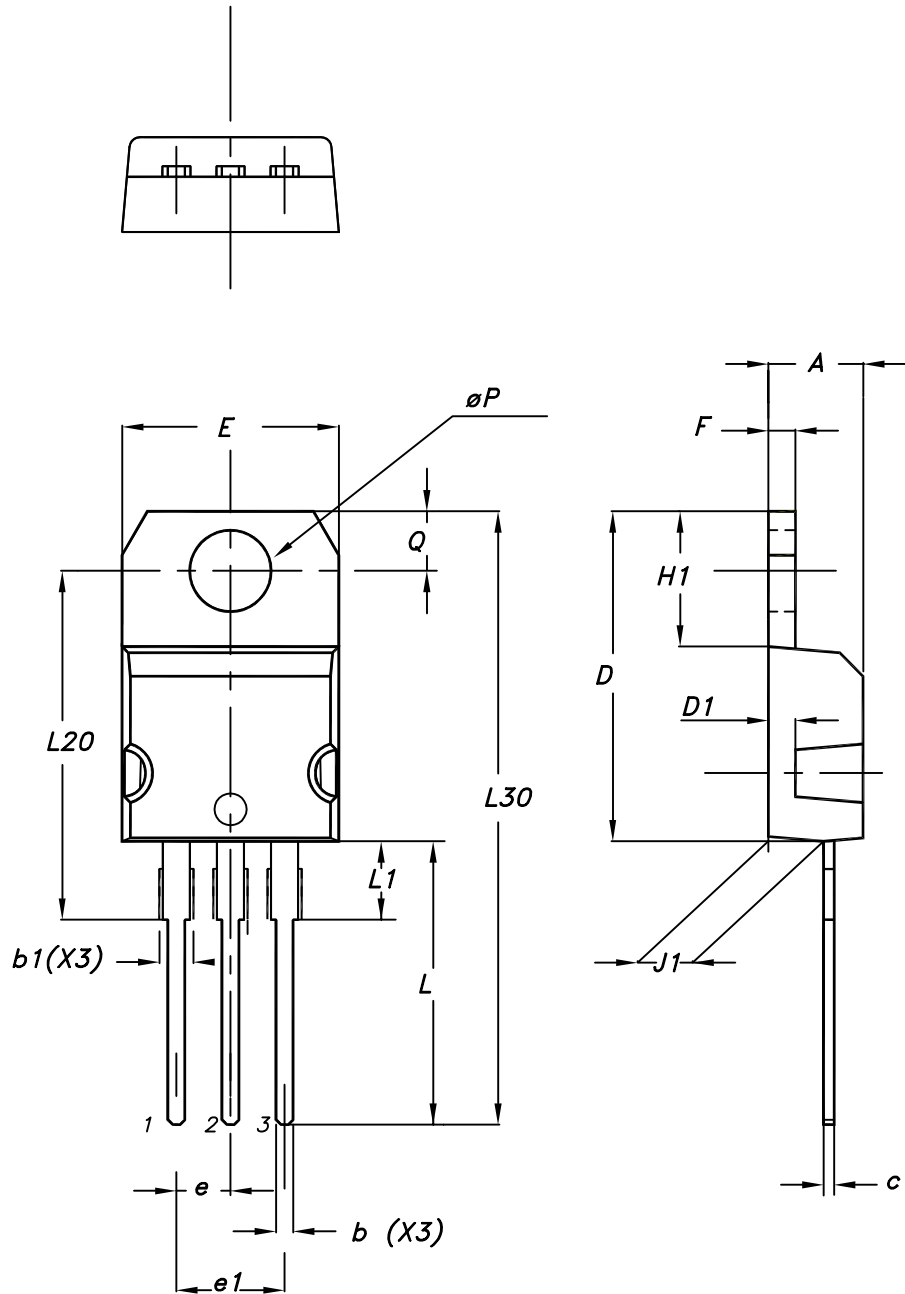
4.6 TO-220 type A package information
Figure 29. TO-220 type A package outline

0015988_typeA_Rev_21

Table 14. TO-220 type A package mechanical data

Dim.	mm		
	Min.	Typ.	Max.
A	4.40		4.60
b	0.61		0.88
b1	1.14		1.55
c	0.48		0.70
D	15.25		15.75
D1		1.27	
E	10.00		10.40
e	2.40		2.70
e1	4.95		5.15
F	1.23		1.32
H1	6.20		6.60
J1	2.40		2.72
L	13.00		14.00
L1	3.50		3.93
L20		16.40	
L30		28.90	
øP	3.75		3.85
Q	2.65		2.95

5 Ordering information

Table 15. Order codes

Order code	Marking	Package	Packing
STB11NK40ZT4	B11NK40Z	D ² PAK	Tape and reel
STP11NK40Z	P11NK40Z	TO-220	Tube
STP11NK40ZFP	P11NK40ZFP	TO-220FP	

Revision history

Table 16. Document revision history

Date	Version	Changes
23-Aug-2005	2	Preliminary version
28-Oct-2005	3	Complete version
26-Jul-2006	4	New template, no content change
22-Nov-2006	5	Corrected unit on <i>Table 5.: On/off states</i>
18-Jan-2007	6	Typo mistakes on page 1
20-Apr-2009	7	Updated mechanical data
02-Oct-2018	8	Updated Section 4 Package information . Minor text changes.

Contents

1	Electrical ratings	2
2	Electrical characteristics	3
2.1	Electrical characteristics curves	5
3	Test circuits	8
4	Package information	9
4.1	D ² PAK (TO-263) type A package information	9
4.2	D ² PAK (TO-263) type B package information	11
4.3	D ² PAK packing information	14
4.4	D ² PAK type B packing information	16
4.5	TO-220FP package information	18
4.6	TO-220 type A package information	20
5	Ordering information	23
	Revision history	24

IMPORTANT NOTICE – PLEASE READ CAREFULLY

STMicroelectronics NV and its subsidiaries (“ST”) reserve the right to make changes, corrections, enhancements, modifications, and improvements to ST products and/or to this document at any time without notice. Purchasers should obtain the latest relevant information on ST products before placing orders. ST products are sold pursuant to ST’s terms and conditions of sale in place at the time of order acknowledgement.

Purchasers are solely responsible for the choice, selection, and use of ST products and ST assumes no liability for application assistance or the design of Purchasers’ products.

No license, express or implied, to any intellectual property right is granted by ST herein.

Resale of ST products with provisions different from the information set forth herein shall void any warranty granted by ST for such product.

ST and the ST logo are trademarks of ST. All other product or service names are the property of their respective owners.

Information in this document supersedes and replaces information previously supplied in any prior versions of this document.

© 2018 STMicroelectronics – All rights reserved



Looking for pricing, stock, or lifecycle information?

Click below to explore more details on WIN SOURCE:

 [View P11NK40ZFP](#) on WIN SOURCE

 [STMicroelectronics](#) Information

Optimize Your Supply Chain with WIN SOURCE Solutions

-  Global Sourcing Solution
-  Obsolete Management
-  Cost Control Management
-  Shortage Management
-  Alternative Solution
-  Excess Inventory Management