



**THE DATASHEET OF
P1819BF-08SR**





Notebook LCD Panel EMI Reduction IC

Features

- FCC approved method of EMI attenuation.
- Provides up to 15dB EMI reduction.
- Generates a low EMI Spread Spectrum clock and a non-spread reference clock of the input frequency.
- Optimized for Frequency range from 20 to 40MHz.
- Internal loop filter minimizes external components and board space.
- Selectable spread options: Down and Center.
- Low Inherent Cycle-to-Cycle jitter.
- Two different deviation selections.
- ModRate is compliant with ATI M7x VGA spec.
- $3.3V \pm 0.3V$ Operating Voltage range.
- Low power CMOS design.
- Supports notebook VGA and other LCD timing controller applications.
- Power Down function for mobile application.
- Available in 8-pin SOIC Package.

Product Description

The P1819 is a Versatile Spread Spectrum Frequency Modulator designed specifically for input clock frequencies from 20 to 40MHz. (Refer to *Input Frequency and Modulation Rate Table*). The P1819 reduces electromagnetic interference (EMI) at the clock source, allowing system wide reduction of EMI of down stream

Block Diagram

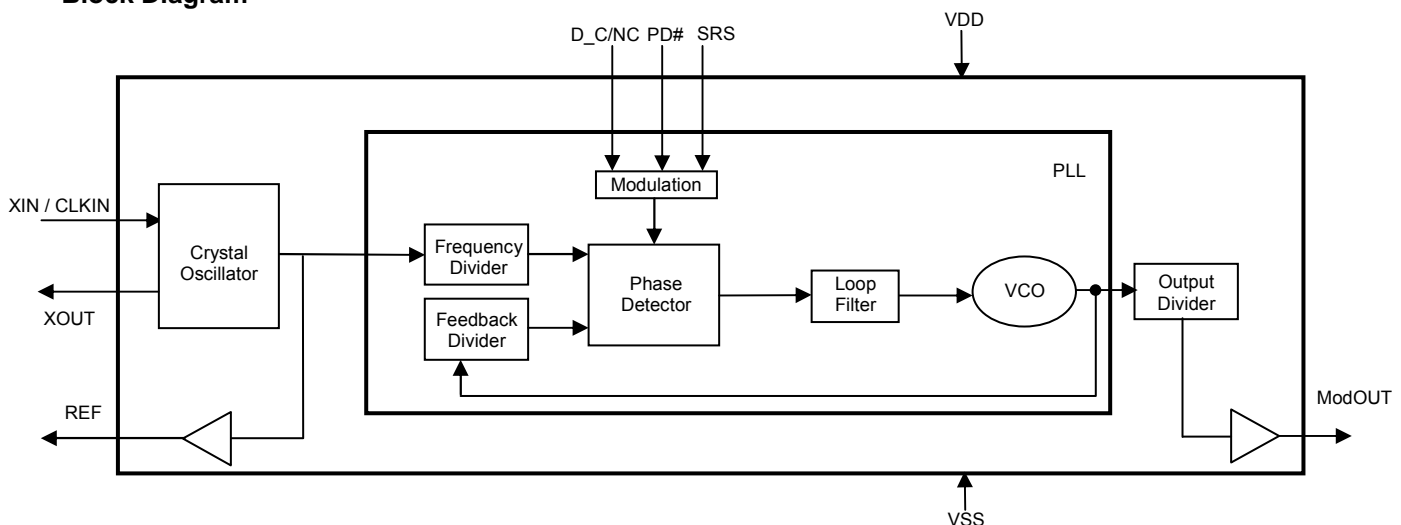

clock and data dependent signals. The P1819 allows significant system cost savings by reducing the number of circuit board layers, ferrite beads, shielding, and other passive components that are traditionally required to pass EMI regulations.

The P1819 modulates the output of a single PLL in order to “spread” the bandwidth of a synthesized clock, and more importantly, decreases the peak amplitudes of its harmonics. This result in significantly lower system EMI compared to the typical narrow band signal produced by oscillators and most frequency generators. Lowering EMI by increasing a signal’s bandwidth is called ‘Spread Spectrum Clock Generation’.

The P1819 is available in different spread deviation, refer to *Spread Deviation Selection Table*.

The P1819 uses the most efficient and optimized modulation profile approved by the FCC and is implemented in a proprietary all digital method.

Applications

The P1819 is targeted towards EMI management for memory and LVDS interfaces in mobile graphic chipsets and high-speed digital applications such as PC peripheral devices, consumer electronics, and embedded controller systems.

Pin Configuration

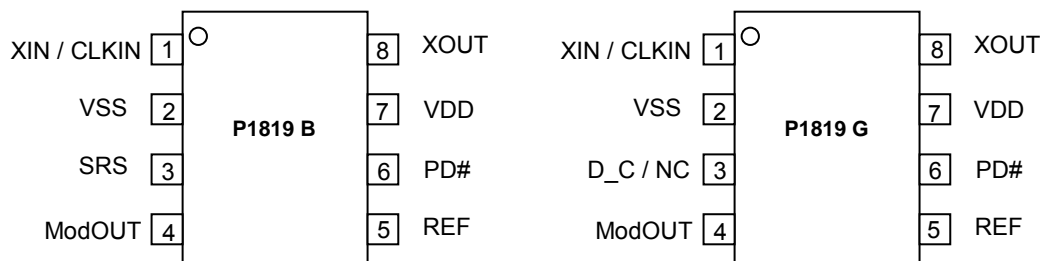

Pin Description

Pin#		Pin Name	Type	Description
P1819B	P1819G			
1	1	XIN / CLKIN	I	Crystal Connection or external frequency input. This pin has dual functions. It can be connected to either an external crystal or an external reference clock.
2	2	VSS	P	Ground Connection. Connect to system ground.
3		SRS	I	Spread range select. Digital logic input used to select frequency deviation (Refer to <i>Spread Deviation Selection Table</i>). This pin has an internal pull-up resistor.
3	3	D_C / NC	I	Digital logic input used to select Down (LOW) or Center (HIGH) spread options (Refer to <i>Spread Deviation Selection Table</i>). This pin has an internal pull-up resistor.
4	4	ModOUT	O	Spread spectrum clock output. (Refer to <i>Input Frequency and Modulation Rate Table and Spread Deviation Selection Table</i>).
5	5	REF	O	Non-modulated Reference clock output of the input frequency.
6	6	PD#	I	Power down control pin. Pull XIN/CLKIN and PD# LOW to enable Power-Down mode. This pin has an internal pull-up resistor.
7	7	VDD	P	Power Supply for the entire chip.
8	8	XOUT	O	Crystal Connection. Input connection for an external crystal. If using an external reference, this pin must be left unconnected.

Note: Pin 3 is NC in P1819Q.

Input Frequency and Modulation Rate

Part Number	Input Frequency Range	Output Frequency range	Modulation rate
P1819	20MHz to 40MHz	20MHz to 40MHz	Input Frequency / 896

Spread Deviation Selection

Part Number	SRS	D_C	Spread Deviation
P1819B	0	NA	-1.25% (DOWN)
	1		-1.75% (DOWN)
P1819G	NA	0	-1.75% (DOWN)
		1	±0.875% (CENTER)

Absolute Maximum Ratings

Symbol	Parameter	Rating	Unit
V_{DD}, V_{IN}	Voltage on any pin with respect to Ground	-0.5 to +4.6	V
T_{STG}	Storage temperature	-65 to +125	°C
T_s	Max. Soldering Temperature (10 sec)	260	°C
T_J	Junction Temperature	150	°C
T_{DV}	Static Discharge Voltage (As per JEDEC STD22- A114-B)	2	KV

Note: These are stress ratings only and are not implied for functional use. Exposure to absolute maximum ratings for prolonged periods of time may affect device reliability.

Operating Conditions

Symbol	Parameter	Min	Max	Unit
VDD	Supply Voltage	3.0	3.6	V
T_A	Operating temperature	-40	+85	°C
C_L	Load Capacitance		15	pF
C_{IN}	Input Capacitance		7	pF

DC Electrical Characteristics

Symbol	Parameter	Min	Typ	Max	Unit
V _{IL}	Input Low voltage	V _{SS} -0.3		0.8	V
V _{IH}	Input High voltage	2.0		V _{DD} +0.3	V
I _{IL}	Input Low current (inputs D_C, PD#, SRS)	-60.0		-20.0	μA
I _{IH}	Input High current			1.0	μA
I _{XOL}	X _{OUT} Output low current @ 0.4V, V _{DD} = 3.3V	2.0		12.0	mA
I _{XOH}	X _{OUT} Output high current @ 2.5V, V _{DD} = 3.3V			12.0	mA
V _{OL}	Output Low voltage V _{DD} = 3.3V, I _{OL} = 20mA			0.4	V
V _{OH}	Output High voltage V _{DD} = 3.3V, I _{OH} = 20mA	2.5		-	V
I _{CC}	Dynamic supply current normal mode 3.3V and 25pF probe loading	7.1 f _{IN} - min		26.9 f _{IN} - max	mA
I _{DD}	Static supply current standby mode		4.5		mA
V _{DD}	Operating Voltage	3.0	3.3	3.6	V
t _{ON}	Power up time (first locked clock cycle after power up)		0.18		mS
Z _{OUT}	Clock Output impedance		50		Ω

AC Electrical Characteristics

Symbol	Parameter	Min	Typ	Max	Unit
f _{IN}	Input Frequency	20		40	MHz
f _{OUT}	Output Frequency	20		40	MHz
t _{LH} ¹	Output Rise time (Measured from 0.8V to 2.0V)		0.66		nS
t _{HL} ¹	Output Fall time (Measured from 2.0V to 0.8V)		0.65		nS
t _{JC}	Jitter (cycle-to-cycle)	-200		200	pS
t _{LTJ}	Long Term Jitter, (1000 cycle) on Refout @ 27MHz		475		pS
t _D	Output Duty cycle	45	50	55	%

Note: 1. t_{LH} and t_{HL} are measured into a capacitive load of 15pF.

Package Information

8-Pin SOIC Package

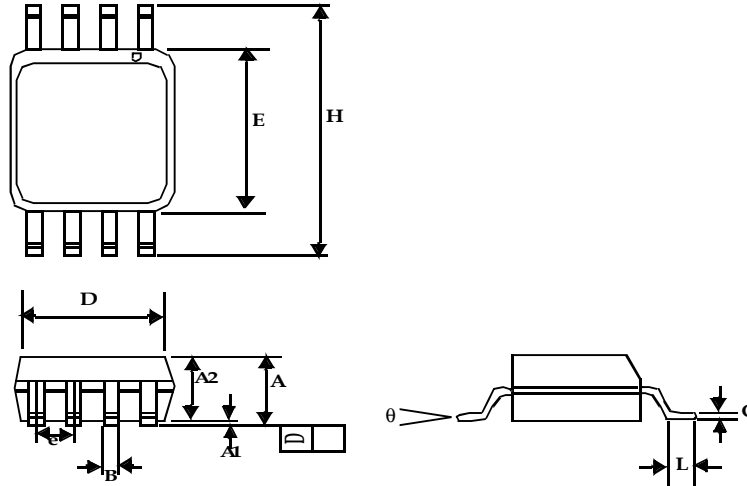

Symbol	Dimensions			
	Inches		Millimeters	
	Min	Max	Min	Max
A1	0.004	0.010	0.10	0.25
A	0.053	0.069	1.35	1.75
A2	0.049	0.059	1.25	1.50
B	0.012	0.020	0.31	0.51
C	0.007	0.010	0.18	0.25
D	0.193 BSC		4.90 BSC	
E	0.154 BSC		3.91 BSC	
e	0.050 BSC		1.27 BSC	
H	0.236 BSC		6.00 BSC	
L	0.016	0.050	0.41	1.27
θ	0°	8°	0°	8°

Note: Controlling dimensions are millimeters
 SOIC – 0.074 grams unit weight

Ordering Code

Part Number	Marking	Package Type	Temperature
P1819BF-08SR	ABY	8-pin SOIC, tape & reel, Pb Free	0°C to +70°C
P1819GF-08SR	ACA	8-pin SOIC, tape & reel, Pb Free	0°C to +70°C

A "microdot" placed at the end of last row of marking or just below the last row toward the center of package indicates Pb-free

ON Semiconductor and  are registered trademarks of Semiconductor Components Industries, LLC (SCILLC). SCILLC reserves the right to make changes without further notice to any products herein. SCILLC makes no warranty, representation or guarantee regarding the suitability of its products for any particular purpose, nor does SCILLC assume any liability arising out of the application or use of any product or circuit, and specifically disclaims any and all liability, including without limitation special, consequential or incidental damages. "Typical" parameters which may be provided in SCILLC data sheets and/or specifications can and do vary in different applications and actual performance may vary over time. All operating parameters, including "Typicals" must be validated for each customer application by customer's technical experts. SCILLC does not convey any license under its patent rights nor the rights of others. SCILLC products are not designed, intended, or authorized for use as components in systems intended for surgical implant into the body, or other applications intended to support or sustain life, or for any other application in which the failure of the SCILLC product could create a situation where personal injury or death may occur. Should Buyer purchase or use SCILLC products for any such unintended or unauthorized application, Buyer shall indemnify and hold SCILLC and its officers, employees, subsidiaries, affiliates, and distributors harmless against all claims, costs, damages, and expenses, and reasonable attorney fees arising out of, directly or indirectly, any claim of personal injury or death associated with such unintended or unauthorized use, even if such claim alleges that SCILLC was negligent regarding the design or manufacture of the part. SCILLC is an Equal Opportunity/Affirmative Action Employer. U.S Patent Pending; Timing-Safe and Active Bead are trademarks of PulseCore Semiconductor, a wholly owned subsidiary of ON Semiconductor. This literature is subject to all applicable copyright laws and is not for resale in any manner.

PUBLICATION ORDERING INFORMATION

LITERATURE FULFILLMENT:

Literature Distribution Center for ON Semiconductor
P.O. Box 5163, Denver, Colorado 80217 USA
Phone: 303-675-2175 or 800-344-3860 Toll Free USA/Canada
Fax: 303-675-2176 or 800-344-3867 Toll Free USA/Canada
Email: orderlit@onsemi.com

N. American Technical Support: 800-282-9855
Toll Free USA/Canada
Europe, Middle East and Africa Technical Support:
Phone: 421 33 790 2910
Japan Customer Focus Center
Phone: 81-3-5773-3850

ON Semiconductor Website:
www.onsemi.com

Order Literature: <http://www.onsemi.com/orderlit>

For additional information, please contact your local Sales Representative

Looking for pricing, stock, or lifecycle information?

Click below to explore more details on WIN SOURCE:

 [View P1819BF-08SR](#) on WIN SOURCE

 [ON Semiconductor](#) Information

Optimize Your Supply Chain with WIN SOURCE Solutions

-  Global Sourcing Solution
-  Obsolete Management
-  Cost Control Management
-  Shortage Management
-  Alternative Solution
-  Excess Inventory Management