



**THE DATASHEET OF  
P1P3800AG12CRTWG**



# P1P3800A

## Phase Synchronizing Clock Generator

### Product Description

P1P3800A is a Phase Synchronizing clock generator that generates four outputs from an input clock. Output frequency will be a divide by two of the input clock. The phase of the output clocks is selectable through four select signals S1, S2, S3 and S4. Refer to *Output Clock Selection Table*. The outputs will go 'low' when all the select signals are 'low'. The transition to a new state of the output will be 'glitch free' when the select inputs change state. A Power Down signal enables the device to be driven to a power save mode, when active. The device works over a supply voltage range of 3.8 V – 5.5 V. The device is available in a 12-Lead 3mmx3mm WQFN package and operates over -40°C to +85°C.

### Features

- Input Clock Frequency:  
120 Hz – 240 Hz (External Reference Clock)
- Output Clock Frequency:  
60 Hz – 120 Hz
- 4 Clock Outputs
- 4 Two Level Controls to Select Sets of Clock Outputs
- Output Buffer Drive Strength: 8 mA
- Supply Voltage: 3.8 V – 5.5 V
- Power Down for Power Save
- 12-Lead 3mmx3mm WQFN Package
- Operating Temperature Range: -40°C to +85°C
- These Devices are Pb-Free, Halogen Free/BFR Free and are RoHS Compliant

### Application

- P1P3800A can be used in applications where Phase Synchronization is needed.

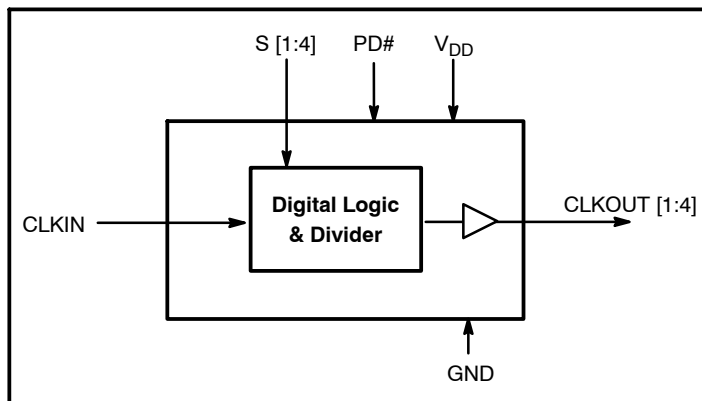
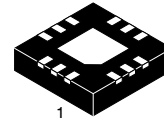

Figure 1. Block Diagram



ON Semiconductor®

<http://onsemi.com>



WQFN12  
CASE 510AH

### MARKING DIAGRAM

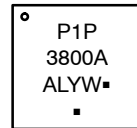

- A = Assembly Location
- L = Wafer Lot
- Y = Year
- W = Work Week
- = Pb-Free Package

(Note: Microdot may be in either location)

### PIN CONFIGURATION

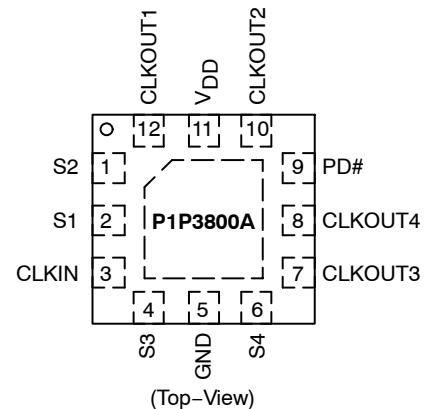

### ORDERING INFORMATION

See detailed ordering and shipping information in the package dimensions section on page 6 of this data sheet.

# P1P3800A

**Table 1. PIN DESCRIPTION**

Pin#	Pin Name	Type	Description
1	S2	I	Output clock select. Refer <i>Output Clock selection</i> table. Has NO default state
2	S1	I	Output clock select. Refer <i>Output Clock selection</i> table. Has NO default state.
3	CLKIN	I	External Reference Clock Input
4	S3	I	Output clock select. Refer <i>Output Clock selection</i> table. Has NO default state.
5	GND	P	Ground to entire chip
6	S4	I	Output clock select. Refer <i>Output Clock selection</i> table. Has NO default state.
7	CLKOUT3	O	Buffered clock output. Refer <i>CLKOUT Diagram</i>
8	CLKOUT4	O	Buffered clock output. Refer <i>CLKOUT Diagram</i>
9	PD#	I	Power Down. Powers down the entire chip when pulled LOW. CLKOUT [1:4] will be LOW when power down is enabled. Has NO default state.
10	CLKOUT2	O	Buffered clock output. Refer <i>CLKOUT Diagram</i>
11	V <sub>DD</sub>	P	Supply Voltage
12	CLKOUT1	O	Buffered clock output. Refer <i>CLKOUT Diagram</i>

**Table 2. OUTPUT CLOCK SELECTION TABLE**

S4	S3	S2	S1	CLKOUT4	CLKOUT3	CLKOUT2	CLKOUT1
0	0	0	0	Low	Low	Low	Low
0	0	0	1	CLK#	CLK#	CLK#	CLK
0	0	1	0	CLK#	CLK#	CLK	CLK#
0	0	1	1	CLK#	CLK#	CLK	CLK
0	1	0	0	CLK#	CLK	CLK#	CLK#
0	1	0	1	CLK#	CLK	CLK#	CLK
0	1	1	0	CLK#	CLK	CLK	CLK#
0	1	1	1	CLK#	CLK	CLK	CLK
1	0	0	0	CLK	CLK#	CLK#	CLK#
1	0	0	1	CLK	CLK#	CLK#	CLK
1	0	1	0	CLK	CLK#	CLK	CLK#
1	0	1	1	CLK	CLK#	CLK	CLK
1	1	0	0	CLK	CLK	CLK#	CLK#
1	1	0	1	CLK	CLK	CLK#	CLK
1	1	1	0	CLK	CLK	CLK	CLK#
1	1	1	1	CLK	CLK	CLK	CLK

# P1P3800A

## CLKOUT Diagram

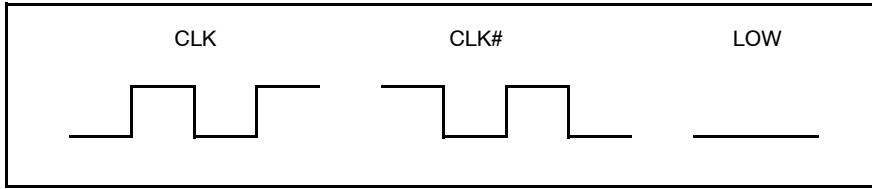

## TIMING Diagram For Glitch Free Operation (For Reference)

(Transition of outputs from any state to any other state)

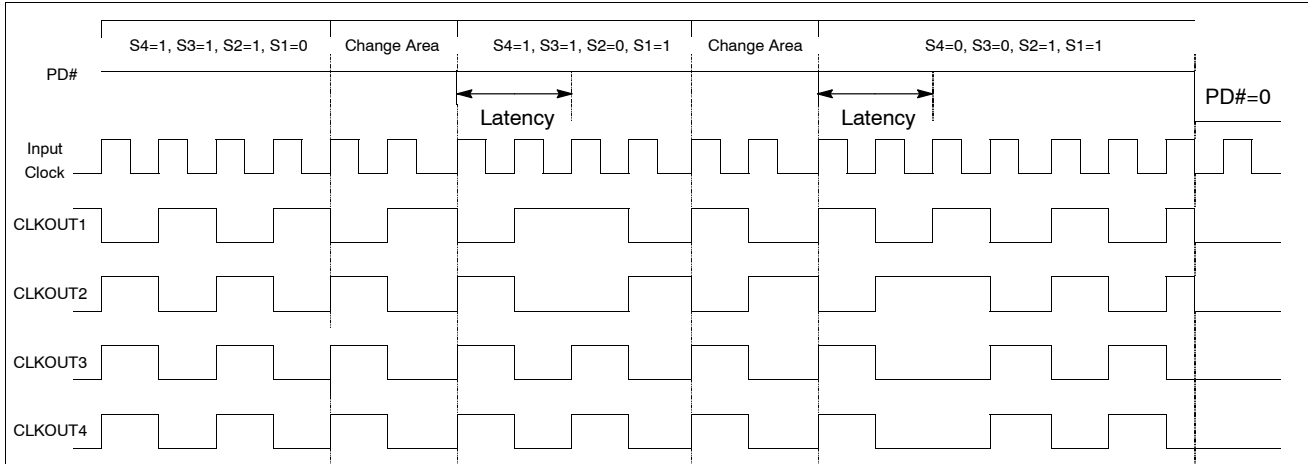

Note: Transition to new state will happen after a latency of one output clock cycle after completing the present output clock cycle  
 Transition to new state will happen after a latency of up to 3 input clock cycles excluding the input cycle where the transition has occurred.

## Power Up

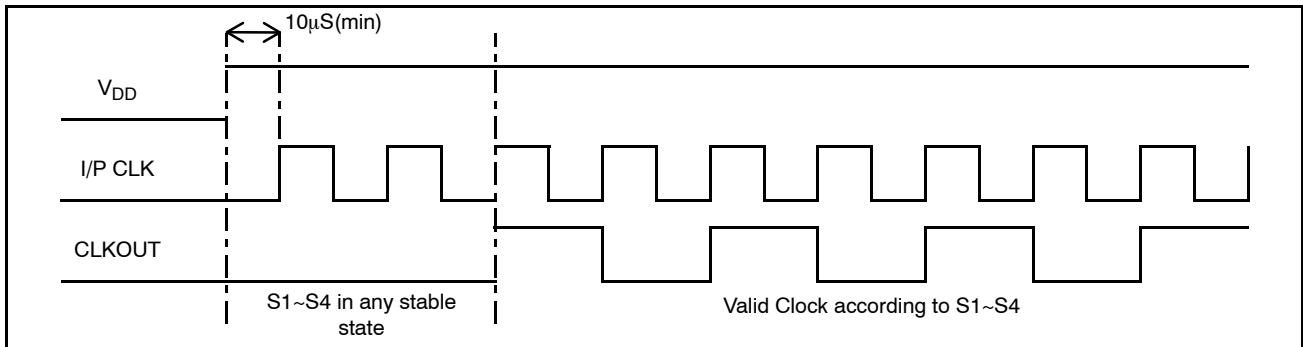

Note: Transition to new state will happen after a latency of up to 2 input clock cycles excluding the input cycle where the transition has occurred.

# P1P3800A

## PD# Operation

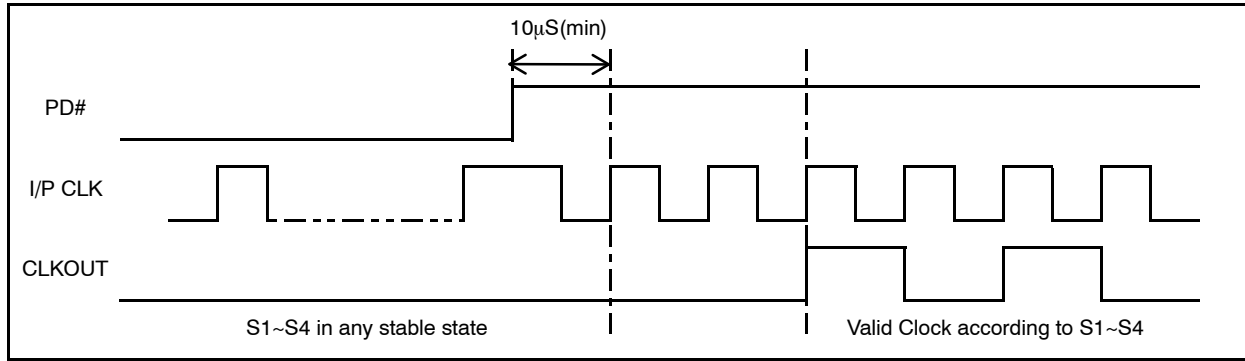

Note: Transition to new state will happen after a latency of up to 2 input clock cycles excluding the input cycle where the transition has occurred.

# P1P3800A

**Table 3. OPERATING CONDITIONS**

Symbol	Parameter	Min	Max	Unit
V <sub>DD</sub>	Supply Voltage	3.8	5.5	V
T <sub>A</sub>	Operating Temperature	-40	+85	°C
C <sub>L</sub>	Load Capacitance		15	pF
C <sub>IN</sub>	Input Capacitance		7.0	pF

**Table 4. ABSOLUTE MAXIMUM RATINGS**

Symbol	Parameter	Rating	Unit
V <sub>DD</sub>	Voltage on V <sub>DD</sub> pin with respect to Ground	-0.5 to +7.0	V
V <sub>IN</sub>	Voltage on any input pin with respect to Ground	-0.5 to +4.0	V
T <sub>STG</sub>	Storage Temperature	-65 to +125	°C
T <sub>s</sub>	Max. Soldering Temperature (10 sec)	260	°C
T <sub>J</sub>	Junction Temperature	150	°C
T <sub>DV</sub>	Static Discharge Voltage (As per JEDEC STD22-A114-B)	2.0	kV

Stresses exceeding Maximum Ratings may damage the device. Maximum Ratings are stress ratings only. Functional operation above the Recommended Operating Conditions is not implied. Extended exposure to stresses above the Recommended Operating Conditions may affect device reliability.

**Table 5. DC ELECTRICAL CHARACTERISTICS**

Symbol	Parameter	Min	Typ	Max	Unit
V <sub>DD</sub>	Operating Voltage	3.8	5.0	5.5	V
V <sub>IL</sub>	Input Low Voltage (Note 1)	GND - 0.3		0.8	V
V <sub>IH</sub>	Input High Voltage (Note 1)	1.6		3.0	V
I <sub>IL</sub>	Input Low Current			10	μA
I <sub>IH</sub>	Input High Current			10	μA
V <sub>OL</sub>	Output Low Voltage	I <sub>OL</sub> = 8 mA		0.4	V
V <sub>OH</sub>	Output High Voltage	I <sub>OH</sub> = -8 mA	V <sub>DD</sub> - 0.6*		V
I <sub>CC</sub>	Power Down Current (PD# pulled to GND)		1.0		μA
I <sub>DD</sub>	**Dynamic Supply Current, PD# = 5.5 V; S[1:4] = 5.5 V/GND; CLKIN Swing = 0 to 5.5 V; V <sub>DD</sub> = 5.5 V			1.8	mA
	Dynamic Supply Current, PD# = 3 V; S[1:4] = 3 V/GND; CLKIN Swing = 0 to 3.0 V			3.0	
	Dynamic Supply Current, PD# = 3 V; S[1:4] = 1.6 V; CLKIN Swing = 0 to 1.6 V			4.0	
	Dynamic Supply Current, PD# = S[1:4] = 1.6 V; CLKIN Swing = 0 to 1.6 V			5.0	

\*For V<sub>DD</sub> = 5 V, V<sub>OH</sub> = V<sub>DD</sub> - 0.4 V.

\*\*Indicative value, not a recommended operating condition.

1. Parameter is guaranteed by design and characterization. Not tested in production.

# P1P3800A

**Table 6. AC ELECTRICAL CHARACTERISTICS**

Symbol	Parameter	Min	Typ	Max	Unit
CLKIN	Input Clock Frequency	120		240	Hz
CLKOUT	Output Clock Frequency	60		120	Hz
$t_{LH}$ , $t_{HL}$	Output Rise / Fall time (Measured from 20% to 80%) (Notes 1, 2)			10	$\mu$ s
$t_{LH}$ , $t_{HL}$	Input Rise / Fall time (Measured from 20% to 80%)			50	$\mu$ s
$t_{DOUT}$	Output Duty Cycle (Measured at $V_{DD}/2$ ) (Notes 1, 2)	49	50	51	%
$t_{DIN}$	Input Duty Cycle	49	50	51	%
$t_{su}$	Set up time for control signals, S[1:4], PD# to input clock rising edge (Note 1)	60			$\mu$ s
$t_h$	Hold up time for control signals, S[1:4], PD# to input clock rising edge (Note 1)	60			$\mu$ s
$t_{skew}$	Output-Output Clock Skew (Note 1)			10	$\mu$ s

2. All parameters are specified with 15 pF loaded output.

## Typical $I_{DD}$ Vs PD# Input Voltage Plot

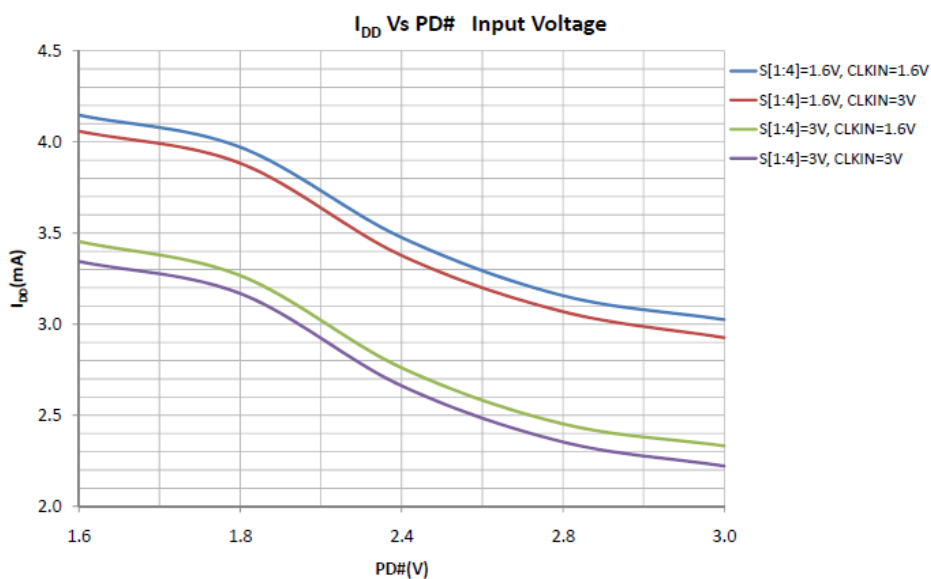

## ORDERING INFORMATION

Part Number	Package	Shipping <sup>†</sup>
P1P3800AG12CRTWG	12 pin (3 mm x 3 mm) WQFN	3000 / Tape & Reel

<sup>†</sup>For information on tape and reel specifications, including part orientation and tape sizes, please refer to our Tape and Reel Packaging Specifications Brochure, BRD8011/D.

# P1P3800A

## PACKAGE DIMENSIONS

WQFN12 3x3, 0.5P  
CASE 510AH  
ISSUE O

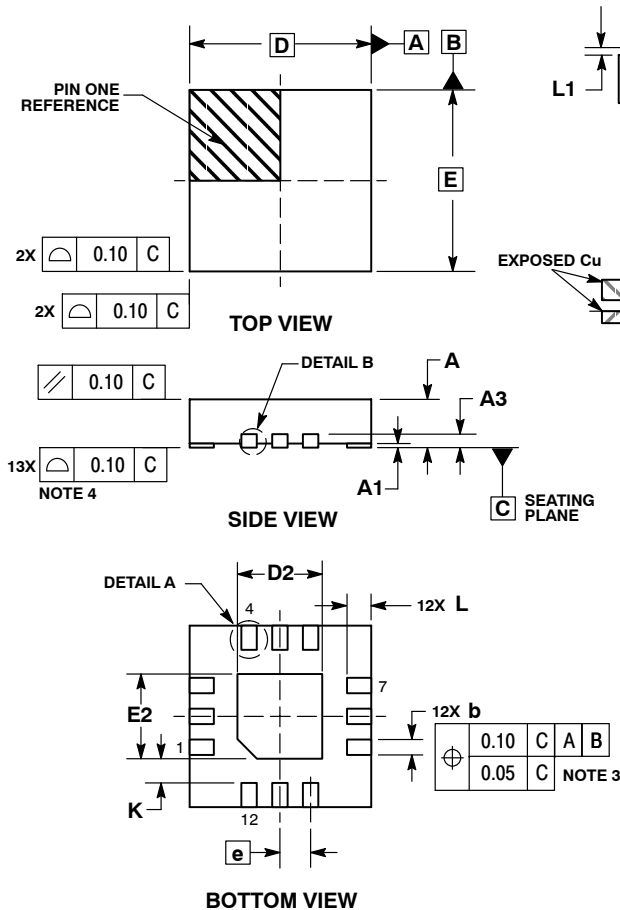

### NOTES:

1. DIMENSIONING AND TOLERANCING PER ASME Y14.5M, 1994.
2. CONTROLLING DIMENSION: MILLIMETERS.
3. DIMENSION b APPLIES TO PLATED TERMINAL AND IS MEASURED BETWEEN 0.15 AND 0.30 MM FROM TERMINAL TIP.
4. COPLANARITY APPLIES TO THE EXPOSED PAD AS WELL AS THE TERMINALS.

MILLIMETERS		
DIM	MIN	MAX
A	0.65	0.85
A1	0.00	0.05
A3	0.22 REF	
b	0.20	0.30
D	3.00 BSC	
E	3.00 BSC	
E2	1.30	1.50
e	0.50 BSC	
K	0.20	---
L	0.30	0.50
L1	0.00	0.15

### SOLDERING FOOTPRINT\*

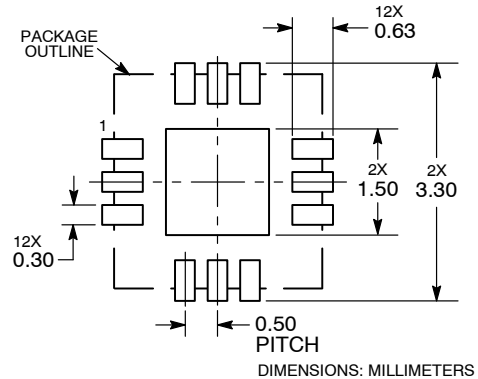

\*For additional information on our Pb-Free strategy and soldering details, please download the ON Semiconductor Soldering and Mounting Techniques Reference Manual, SOLDERRM/D.

ON Semiconductor and are registered trademarks of Semiconductor Components Industries, LLC (SCILLC). SCILLC reserves the right to make changes without further notice to any products herein. SCILLC makes no warranty, representation or guarantee regarding the suitability of its products for any particular purpose, nor does SCILLC assume any liability arising out of the application or use of any product or circuit, and specifically disclaims any and all liability, including without limitation special, consequential or incidental damages. "Typical" parameters which may be provided in SCILLC data sheets and/or specifications can and do vary in different applications and actual performance may vary over time. All operating parameters, including "Typicals" must be validated for each customer application by customer's technical experts. SCILLC does not convey any license under its patent rights nor the rights of others. SCILLC products are not designed, intended, or authorized for use as components in systems intended for surgical implant into the body, or other applications intended to support or sustain life, or for any other application in which the failure of the SCILLC product could create a situation where personal injury or death may occur. Should Buyer purchase or use SCILLC products for any such unintended or unauthorized application, Buyer shall indemnify and hold SCILLC and its officers, employees, subsidiaries, affiliates, and distributors harmless against all claims, costs, damages, and expenses, and reasonable attorney fees arising out of, directly or indirectly, any claim of personal injury or death associated with such unintended or unauthorized use, even if such claim alleges that SCILLC was negligent regarding the design or manufacture of the part. SCILLC is an Equal Opportunity/Affirmative Action Employer. This literature is subject to all applicable copyright laws and is not for resale in any manner.

### PUBLICATION ORDERING INFORMATION

**LITERATURE FULFILLMENT:**  
Literature Distribution Center for ON Semiconductor  
P.O. Box 5163, Denver, Colorado 80217 USA  
**Phone:** 303-675-2175 or 800-344-3860 Toll Free USA/Canada  
**Fax:** 303-675-2176 or 800-344-3867 Toll Free USA/Canada  
**Email:** orderlit@onsemi.com



**N. American Technical Support:** 800-282-9855 Toll Free  
USA/Canada  
**Europe, Middle East and Africa Technical Support:**  
Phone: 421 33 790 2910  
**Japan Customer Focus Center**  
Phone: 81-3-5817-1050

**ON Semiconductor Website:** [www.onsemi.com](http://www.onsemi.com)  
**Order Literature:** <http://www.onsemi.com/orderlit>

For additional information, please contact your local Sales Representative

## Looking for pricing, stock, or lifecycle information?

Click below to explore more details on WIN SOURCE:

-  [View P1P3800AG12CRTWG on WIN SOURCE](#)
-  [ON Semiconductor Information](#)

## Optimize Your Supply Chain with WIN SOURCE Solutions

-  Global Sourcing Solution
-  Obsolete Management
-  Cost Control Management
-  Shortage Management
-  Alternative Solution
-  Excess Inventory Management