



## P82B96 I<sup>2</sup>C Compatible Dual Bidirectional Bus Buffer

### 1 Features

- Operating Power-Supply Voltage Range of 2 V to 15 V
- Can Interface Between I<sup>2</sup>C Buses Operating at Different Logic Levels (2 V to 15 V)
- Longer Cables by allowing bus capacitance of 400 pF on Main Side (Sx/Sy) and 4000 pF on Transmission Side (Tx/Ty)
- Outputs on the Transmission Side (Tx/Ty) Have High Current Sink Capability for Driving Low-Impedance or High-Capacitive Buses
- Interface With Optoelectrical Isolators and Similar Devices That Need Unidirectional Input and Output Signal Paths by Splitting I<sup>2</sup>C Bus Signals Into Pairs of Forward (Tx/Ty) and Reverse (Rx/Ry) Signals
- 400-kHz Fast I<sup>2</sup>C Bus Operation Over at Least 20 Meters of Wire
- Latch-Up Performance Exceeds 100 mA Per JESD 78, Class II
- ESD Protection Exceeds JESD 22

### 2 Applications

- HDMI DDC
- Long I<sup>2</sup>C Communication
- Galvanic I<sup>2</sup>C Isolation
- Industrial Communications

### 3 Description

The P82B96 device is a bus buffer that supports bidirectional data transfer between an I<sup>2</sup>C bus and a range of other bus configurations with different voltage and current levels.

One of the advantages of the P82B96 is that it supports longer cables/traces and allows for more devices per I<sup>2</sup>C bus because it can isolate bus capacitance such that the total loading (devices and trace lengths) of the new bus or remote I<sup>2</sup>C nodes are not apparent to other I<sup>2</sup>C buses (or nodes). The restrictions on the number of I<sup>2</sup>C devices in a system due to capacitance, or the physical separation between them, are greatly improved.

The device is able to provide galvanic isolation (optocoupling) or use balanced transmission lines (twisted pairs), because separate directional Tx and Rx signals are provided. The Tx and Rx signals may be connected directly (without causing bus latching), to provide an bidirectional signal line with I<sup>2</sup>C properties (open-drain driver). Likewise, the Ty and Ry signals may also be connected together to provide an bidirectional signal line with I<sup>2</sup>C properties (open-drain driver). This allows for a simple communication design, saving design time and costs.

#### Device Information<sup>(1)</sup>

PART NUMBER	PACKAGE	BODY SIZE (NOM)
P82B96	SOIC (8)	4.90 mm × 3.91 mm
	VSSOP (8)	3.00 mm × 3.00 mm
	PDIP (8)	9.81 mm × 6.35 mm
	TSSOP (8)	3.00 mm × 4.40 mm

(1) For all available packages, see the orderable addendum at the end of the data sheet.

### Long-Distance I<sup>2</sup>C Communications

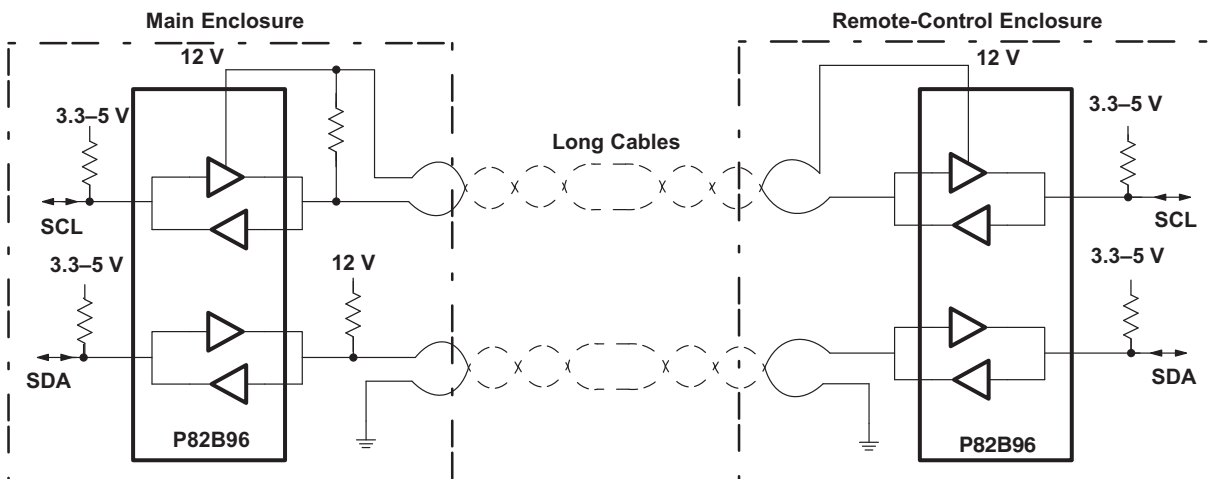

## Table of Contents

<b>1 Features</b> .....	<b>1</b>	<b>9 Detailed Description</b> .....	<b>13</b>
<b>2 Applications</b> .....	<b>1</b>	9.1 Overview .....	13
<b>3 Description</b> .....	<b>1</b>	9.2 Functional Block Diagram .....	13
<b>4 Revision History</b> .....	<b>2</b>	9.3 Feature Description .....	14
<b>5 Description (continued)</b> .....	<b>3</b>	9.4 Device Functional Modes .....	14
<b>6 Pin Configuration and Functions</b> .....	<b>4</b>	<b>10 Application and Implementation</b> .....	<b>15</b>
<b>7 Specifications</b> .....	<b>5</b>	10.1 Application Information .....	15
7.1 Absolute Maximum Ratings .....	5	10.2 Typical Applications .....	17
7.2 ESD Ratings .....	5	<b>11 Power Supply Recommendations</b> .....	<b>21</b>
7.3 Recommended Operating Conditions .....	5	<b>12 Layout</b> .....	<b>21</b>
7.4 Thermal Information .....	5	12.1 Layout Guidelines .....	21
7.5 Electrical Characteristics: $V_{CC} = 2.3\text{ V to }2.7\text{ V}$ .....	6	12.2 Layout Example .....	21
7.6 Electrical Characteristics: $V_{CC} = 3\text{ V to }3.6\text{ V}$ .....	7	<b>13 Device and Documentation Support</b> .....	<b>22</b>
7.7 Electrical Characteristics: $V_{CC} = 4.5\text{ V to }5.5\text{ V}$ .....	8	13.1 Community Resources .....	22
7.8 Electrical Characteristics: $V_{CC} = 15\text{ V}$ .....	9	13.2 Trademarks .....	22
7.9 Switching Characteristics .....	10	13.3 Electrostatic Discharge Caution .....	22
7.10 Typical Characteristics .....	11	13.4 Glossary .....	22
<b>8 Parameter Measurement Information</b> .....	<b>12</b>	<b>14 Mechanical, Packaging, and Orderable Information</b> .....	<b>22</b>

## 4 Revision History

### Changes from Revision B (July 2007) to Revision C

Page

- Added *Pin Configuration and Functions* section, *ESD Ratings* table, *Feature Description* section, *Device Functional Modes*, *Application and Implementation* section, *Power Supply Recommendations* section, *Layout* section, *Device and Documentation Support* section, and *Mechanical, Packaging, and Orderable Information* section ..... **1**
- Changed  $V_{CC}$  pins to VCC pins in pinout diagrams .....

## 5 Description (continued)

Two or more Sx or Sy I/Os must not be connected to each other on the same node. The P82B96 design does not support this configuration. Bidirectional I<sup>2</sup>C signals do not have a direction control pin so, instead, slightly different logic low-voltage levels are used at Sx/Sy to avoid latching of this buffer. A standard I<sup>2</sup>C low applied at the Rx/Ry of a P82B96 is propagated to Sx/Sy as a buffered low with a slightly higher voltage level. If this special buffered low is applied to the Sx/Sy of another P82B96, the second P82B96 does not recognize it as a standard I<sup>2</sup>C bus low and does not propagate it to its Tx/Ty output. The Sx/Sy side of P82B96 may not be connected to similar buffers that rely on special logic thresholds for their operation.

The Sx/Sy side of the P82B96 is intended for I<sup>2</sup>C logic voltage levels of I<sup>2</sup>C master and slave devices or Tx/Rx signals of a second P82B96, if required. If Rx and Tx are connected, Sx can function as either the SDA or SCL line. Similarly, if Ry and Ty are connected, Sy can function as either the SDA or SCL line. There are no restrictions on the interconnection of the Tx/Rx and Ty/Ry I/O pins to other P82B96s, for example in a star or multi-point configuration (multiple P82B96 devices share the same Tx/Rx and Ty/Ry nodes) with the Tx/Rx and Ty/Ry I/O pins on the common bus, and the Sx/Sy side connected to the line-card slave devices.

In any design, the Sx pins of different devices should never be linked, because the resulting system would be very susceptible to induced noise and would not support all I<sup>2</sup>C operating modes.

## 6 Pin Configuration and Functions

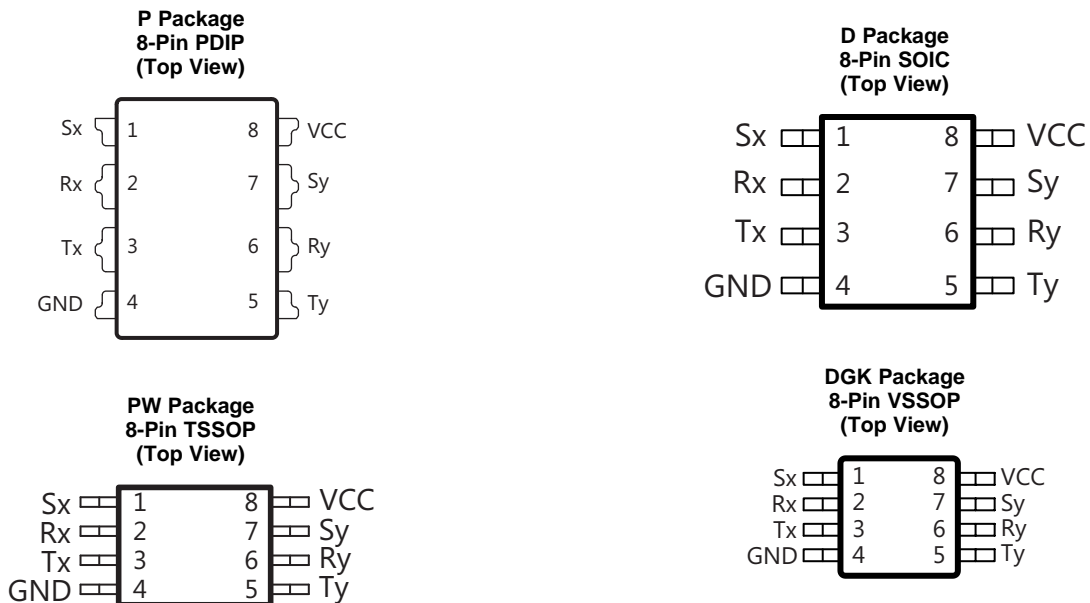

### Pin Functions

PIN		I/O	DESCRIPTION
NO.	NAME		
1	Sx	I/O	Serial data bus or SDA. Connect to $V_{CC}$ of I <sup>2</sup> C master through a pullup resistor.
2	Rx	I	Receive signal. Connect to $V_{CC}$ of P82B96 through a pullup resistor.
3	Tx	O	Transmit signal. Connect to $V_{CC}$ of P82B96 through a pullup resistor.
4	GND	—	Ground
5	Ty	O	Transmit signal. Connect to $V_{CC}$ of P82B96 through a pullup resistor.
6	Ry	I	Receive signal. Connect to $V_{CC}$ of P82B96 through a pullup resistor.
7	Sy	I/O	Serial clock bus or SCL. Connect to $V_{CC}$ of I <sup>2</sup> C master through a pullup resistor.
8	VCC	I	Supply voltage

## 7 Specifications

### 7.1 Absolute Maximum Ratings

over operating free-air temperature range (unless otherwise noted)<sup>(1)</sup>

		MIN	MAX	UNIT	
V <sub>CC</sub>	Supply voltage on VCC pin	-0.3	18	V	
V <sub>I</sub>	Voltage on buffered input	Sx or Sy (SDA or SCL)	-0.3	18	V
		Rx or Ry	-0.3	18	
V <sub>O</sub>	Voltage on buffered output	Sx or Sy (SDA or SCL)	-0.3	18	V
		Tx or Ty	-0.3	18	
I <sub>O</sub>	Continuous output current	Sx or Sy		250	mA
		Tx or Ty		250	
I <sub>CC</sub>	Continuous current through VCC or GND		250	mA	
T <sub>A</sub>	Operating free-air temperature	-40	85	°C	
T <sub>stg</sub>	Storage temperature	-55	125	°C	

(1) Stresses beyond those listed under *Absolute Maximum Ratings* may cause permanent damage to the device. These are stress ratings only, and functional operation of the device at these or any other conditions beyond those indicated under *Recommended Operating Conditions* is not implied. Exposure to absolute-maximum-rated conditions for extended periods may affect device reliability.

### 7.2 ESD Ratings

		VALUE	UNIT	
V <sub>(ESD)</sub>	Electrostatic discharge	Human Body Model (HBM), per ANSI/ESDA/JEDEC JS-001 <sup>(1)</sup>	±3500	V
		Charged-Device Model (CDM), per JEDEC specification JESD22-C101 <sup>(2)</sup>	±1000	
		Machine Model (MM), per JEDEC specification JESD22-A115-A	±200	

(1) JEDEC document JEP155 states that 500-V HBM allows safe manufacturing with a standard ESD control process.

(2) JEDEC document JEP157 states that 250-V CDM allows safe manufacturing with a standard ESD control process.

### 7.3 Recommended Operating Conditions

		MIN	MAX	UNIT	
V <sub>CC</sub>	Supply voltage	2	15	V	
I <sub>OL</sub>	Low-level output current	Sx, Sy	V <sub>Sx</sub> , V <sub>Sy</sub> = 1 V, V <sub>Rx</sub> , V <sub>Ry</sub> ≤ 0.42 V	3	mA
		Tx, Ty	V <sub>Sx</sub> , V <sub>Sy</sub> = 0.4 V, V <sub>Tx</sub> , V <sub>Ty</sub> = 0.4 V	30	
V <sub>IOmax</sub>	Maximum input/output voltage level	Sx, Sy	V <sub>Tx</sub> , V <sub>Ty</sub> = 0.4 V	15	V
		Tx, Ty	V <sub>Sx</sub> , V <sub>Sy</sub> = 0.4 V	15	
V <sub>ILdiff</sub>	Low-level input voltage difference		0.4	V	
T <sub>A</sub>	Operating free-air temperature	-40	85	°C	

### 7.4 Thermal Information

THERMAL METRIC <sup>(1)</sup>	P82B96				UNIT	
	D (SOIC)	DGK (VSSOP)	P (PDIP)	PW (TSSOP)		
	8 PINS	8 PINS	8 PINS	8 PINS		
R <sub>θJA</sub>	Junction-to-ambient thermal resistance	109.1	174.3	53.5	173.5	°C/W
R <sub>θJC(top)</sub>	Junction-to-case (top) thermal resistance	61.6	63	44.4	57.6	°C/W
R <sub>θJB</sub>	Junction-to-board thermal resistance	48.6	94.2	30.6	101.8	°C/W
ψ <sub>JT</sub>	Junction-to-top characterization parameter	19.6	8.1	22.9	5.3	°C/W
ψ <sub>JB</sub>	Junction-to-board characterization parameter	48.2	92.8	30.5	100.2	°C/W

(1) For more information about traditional and new thermal metrics, see the *Semiconductor and IC Package Thermal Metrics* application report, [SPRA953](#).

### 7.5 Electrical Characteristics: $V_{CC} = 2.3\text{ V to }2.7\text{ V}$

$V_{CC} = 2.3\text{ V to }2.7\text{ V}$ , voltages are specified with respect to GND (unless otherwise noted)

PARAMETER		TEST CONDITIONS	$T_A = 25^\circ\text{C}$			$T_A = -40^\circ\text{C to }85^\circ\text{C}$		UNIT		
			MIN	TYP <sup>(1)</sup>	MAX	MIN	MAX			
$\Delta V/\Delta T_{IN}$	Temperature coefficient of input thresholds	Sx, Sy	-2					mV/°C		
$V_{OL}$	Low-level output voltage	Sx, Sy	$I_{Sx}, I_{Sy} = 3\text{ mA}$	0.8	0.88	1	See <sup>(2)</sup>		V	
			$I_{Sx}, I_{Sy} = 0.2\text{ mA}$	0.67	0.73	0.79	See <sup>(2)</sup>			
$\Delta V/\Delta T_{OUT}$	Temperature coefficient of output low levels <sup>(3)</sup>	Sx, Sy	$I_{Sx}, I_{Sy} = 0.2\text{ mA}$			-1.8		mV/°C		
$I_{CC}$	Quiescent supply current		$Sx = Sy = V_{CC}$			0.9	1.8	2	mA	
$\Delta I_{CC}$	Additional supply current per pin low	Tx, Ty				1.7	2.75	3	mA	
$I_{IOS}$	Dynamic output sink capability on I <sup>2</sup> C bus	Sx, Sy	$V_{Sx}, V_{Sy} > 2\text{ V}, V_{Rx}, V_{Ry} = \text{low}$			7	18	5.5	mA	
	Leakage current on I <sup>2</sup> C bus		$V_{Sx}, V_{Sy} = 2.5\text{ V}, V_{Rx}, V_{Ry} = \text{high}$				0.1	1	1	µA
$I_{IOT}$	Dynamic output sink capability on buffered bus	Tx, Ty	$V_{Tx}, V_{Ty} > 1\text{ V}, V_{Sx}, V_{Sy} = \text{low on I}^2\text{C bus} = 0.4\text{ V}$			60	100	60	mA	
	Leakage current on buffered bus		$V_{Tx}, V_{Ty} = V_{CC} = 2.5\text{ V}, V_{Sx}, V_{Sy} = \text{high}$				0.1	1	1	µA
$I_I$	Input current from I <sup>2</sup> C bus	Sx, Sy	Bus low, $V_{Rx}, V_{Ry} = \text{high}$				-1	1	µA	
	Input current from buffered bus	Rx, Ry	Bus low, $V_{Rx}, V_{Ry} = 0.4\text{ V}$				-1	1		
	Leakage current on buffered bus input		$V_{Rx}, V_{Ry} = V_{CC}$				1	1.5		
$V_{IT}$	Input threshold	Sx, Sy	Input logic level high threshold <sup>(4)</sup> on normal I <sup>2</sup> C bus			0.65	0.7	See <sup>(2)</sup>		V
			Input logic level low threshold <sup>(4)</sup> on normal I <sup>2</sup> C bus			0.6	0.65	See <sup>(2)</sup>		
		Rx, Ry	Input logic level high			$0.58 \times V_{CC}$		$0.58 \times V_{CC}$		
			Input threshold			$0.5 \times V_{CC}$				
Input logic level low			$0.42 \times V_{CC}$		$0.42 \times V_{CC}$					
$V_{IOdiff}$	Input/output logic level difference <sup>(5)</sup>	Sx, Sy	$(V_{Sx} \text{ output low at } 3\text{ mA}) - (V_{Sx} \text{ input high max})$ for I <sup>2</sup> C applications			100	150	100	mV	
$V_{IOrel}$	$V_{CC}$ voltage at which all buses are released	Sx, Sy Tx, Ty	Sx, Sy are low, $V_{CC}$ ramping, voltage on Tx, Ty lowered until released			1		1	V	
$\Delta V/\Delta T_{REL}$	Temperature coefficient of release voltage					-4			mV/°C	
$C_{in}$	Input capacitance	Rx, Ry				2.5	4	4	pF	

- (1) Typical value is at  $V_{CC} = 2.5\text{ V}, T_A = 25^\circ\text{C}$
- (2) See the [Typical Characteristics](#) section of this data sheet.
- (3) The output logic low depends on the sink current.
- (4) The input logic threshold is independent of the supply voltage.
- (5) The minimum value requirement for pullup current, 200 µA, ensures that the minimum value for  $V_{Sx}$  output low always exceeds the minimum  $V_{Sx}$  input high level to eliminate any possibility of latching. The specified difference is specified by design within any device. While the tolerances on absolute levels allow a small probability that the low from one Sx output is recognized by an Sx input of another P82B96, this has no consequences for normal applications.

## 7.6 Electrical Characteristics: $V_{CC} = 3\text{ V to }3.6\text{ V}$

 $V_{CC} = 3\text{ V to }3.6\text{ V}$ , voltages are specified with respect to GND (unless otherwise noted)

PARAMETER		TEST CONDITIONS	$T_A = 25^\circ\text{C}$			$T_A = -40^\circ\text{C to }85^\circ\text{C}$		UNIT		
			MIN	TYP <sup>(1)</sup>	MAX	MIN	MAX			
$\Delta V/\Delta T_{IN}$	Temperature coefficient of input thresholds	Sx, Sy	–2					mV/°C		
$V_{OL}$	Low-level output voltage	Sx, Sy	$I_{Sx}, I_{Sy} = 3\text{ mA}$	0.8	0.88	1	See <sup>(2)</sup>		V	
			$I_{Sx}, I_{Sy} = 0.2\text{ mA}$	0.67	0.73	0.79	See <sup>(2)</sup>			
$\Delta V/\Delta T_{OUT}$	Temperature coefficient of output low levels <sup>(3)</sup>	Sx, Sy	$I_{Sx}, I_{Sy} = 0.2\text{ mA}$			–1.8		mV/°C		
$I_{CC}$	Quiescent supply current	$Sx = Sy = V_{CC}$		0.9	1.8		2	mA		
$\Delta I_{CC}$	Additional supply current per pin low	Tx, Ty	1.7			2.75		3	mA	
$I_{IOS}$	Dynamic output sink capability on I <sup>2</sup> C bus	Sx, Sy	$V_{Sx}, V_{Sy} > 2\text{ V}, V_{Rx}, V_{Ry} = \text{low}$			7		18	5.7	mA
	Leakage current on I <sup>2</sup> C bus		$V_{Sx}, V_{Sy} = 5\text{ V}, V_{Rx}, V_{Ry} = \text{high}$			0.1		1	1	µA
$I_{IOT}$	Dynamic output sink capability on buffered bus	Tx, Ty	$V_{Tx}, V_{Ty} > 1\text{ V}, V_{Sx}, V_{Sy} = \text{low on I}^2\text{C bus} = 0.4\text{ V}$			60		100	60	mA
	Leakage current on buffered bus		$V_{Tx}, V_{Ty} = V_{CC} = 3.3\text{ V}, V_{Sx}, V_{Sy} = \text{high}$			0.1		1	1	µA
$I_I$	Input current from I <sup>2</sup> C bus	Sx, Sy	Bus low, $V_{Rx}, V_{Ry} = \text{high}$			–1		1	µA	
	Input current from buffered bus	Rx, Ry	Bus low, $V_{Rx}, V_{Ry} = 0.4\text{ V}$			–1		1		
	Leakage current on buffered bus input		$V_{Rx}, V_{Ry} = V_{CC}$			1		1.5		
$V_{IT}$	Input threshold	Sx, Sy	Input logic-level high threshold <sup>(4)</sup> on normal I <sup>2</sup> C bus			0.65		0.7	See <sup>(2)</sup>	
			Input logic-level low threshold <sup>(4)</sup> on normal I <sup>2</sup> C bus			0.6		0.65	See <sup>(2)</sup>	
		Rx, Ry	Input logic level high			$0.58 \times V_{CC}$		$0.58 \times V_{CC}$		
			Input threshold			$0.5 \times V_{CC}$				
Input logic level low					$0.42 \times V_{CC}$		$0.42 \times V_{CC}$			
$V_{IOdiff}$	Input/output logic level difference <sup>(5)</sup>	Sx, Sy	$(V_{Sx} \text{ output low at } 3\text{ mA}) - (V_{Sx} \text{ input high max})$ for I <sup>2</sup> C applications			100		150	100	mV
$V_{IOrel}$	$V_{CC}$ voltage at which all buses are released	Sx, Sy Tx, Ty	Sx, Sy are low, $V_{CC}$ ramping, voltage on Tx, Ty lowered until released			1		1		V
$\Delta V/\Delta T_{REL}$	Temperature coefficient of release voltage				–4					mV/°C
$C_{in}$	Input capacitance	Rx, Ry				2.5		4	4	pF

(1) Typical value is at  $V_{CC} = 3.3\text{ V}, T_A = 25^\circ\text{C}$

(2) See the [Typical Characteristics](#) section of this data sheet.

(3) The output logic low depends on the sink current.

(4) The input logic threshold is independent of the supply voltage.

(5) The minimum value requirement for pullup current, 200 µA, ensures that the minimum value for  $V_{Sx}$  output low always exceeds the minimum  $V_{Sx}$  input high level to eliminate any possibility of latching. The specified difference is specified by design within any device. While the tolerances on absolute levels allow a small probability that the low from one Sx output is recognized by an Sx input of another P82B96, this has no consequences for normal applications.

### 7.7 Electrical Characteristics: $V_{CC} = 4.5\text{ V to }5.5\text{ V}$

$V_{CC} = 4.5\text{ V to }5.5\text{ V}$ , voltages are specified with respect to GND (unless otherwise noted)

PARAMETER		TEST CONDITIONS	$T_A = 25^\circ\text{C}$			$T_A = -40^\circ\text{C to }85^\circ\text{C}$		UNIT
			MIN	TYP <sup>(1)</sup>	MAX	MIN	MAX	
$\Delta V/\Delta T_{IN}$	Temperature coefficient of input thresholds	Sx, Sy		-2				mV/°C
$V_{OL}$	Low-level output voltage	Sx, Sy	$I_{Sx}, I_{Sy} = 3\text{ mA}$	0.8	0.88	1	See <sup>(2)</sup>	V
			$I_{Sx}, I_{Sy} = 0.2\text{ mA}$	0.67	0.73	0.79	See <sup>(2)</sup>	
$\Delta V/\Delta T_{OUT}$	Temperature coefficient of output low levels <sup>(3)</sup>	Sx, Sy	$I_{Sx}, I_{Sy} = 0.2\text{ mA}$		-1.8			mV/°C
$I_{CC}$	Quiescent supply current	$Sx = Sy = V_{CC}$		0.9	1.8		2	mA
$\Delta I_{CC}$	Additional supply current per pin low	Tx, Ty		1.7	2.75		3	mA
$I_{IOS}$	Dynamic output sink capability on I <sup>2</sup> C bus	Sx, Sy	$V_{Sx}, V_{Sy} > 2\text{ V}$ , $V_{Rx}, V_{Ry} = \text{low}$	7	18		6	mA
	Leakage current on I <sup>2</sup> C bus		$V_{Sx}, V_{Sy} = 5\text{ V}$ , $V_{Rx}, V_{Ry} = \text{high}$		0.1	1		1
$I_{IOT}$	Dynamic output sink capability on buffered bus	Tx, Ty	$V_{Tx}, V_{Ty} > 1\text{ V}$ , $V_{Sx}, V_{Sy} = \text{low on I}^2\text{C bus} = 0.4\text{ V}$	60	100		60	mA
	Leakage current on buffered bus		$V_{Tx}, V_{Ty} = V_{CC} = 5\text{ V}$ , $V_{Sx}, V_{Sy} = \text{high}$		0.1	1		1
$I_I$	Input current from I <sup>2</sup> C bus	Sx, Sy	Bus low, $V_{Rx}, V_{Ry} = \text{high}$		-1			1
	Input current from buffered bus	Rx, Ry	Bus low, $V_{Rx}, V_{Ry} = 0.4\text{ V}$		-1			1
	Leakage current on buffered bus input		$V_{Rx}, V_{Ry} = V_{CC}$			1		1.5
$V_{IT}$	Input threshold	Sx, Sy	Input logic-level high threshold <sup>(4)</sup> on normal I <sup>2</sup> C bus		0.65	0.7	See <sup>(2)</sup>	V
			Input logic-level low threshold <sup>(4)</sup> on normal I <sup>2</sup> C bus	0.6	0.65		See <sup>(2)</sup>	
		Rx, Ry	Input logic level high		$0.58 \times V_{CC}$		$0.58 \times V_{CC}$	
			Input logic level low			$0.42 \times V_{CC}$	$0.42 \times V_{CC}$	
$V_{IOdiff}$	Input/output logic level difference <sup>(5)</sup>	Sx, Sy	$(V_{Sx} \text{ output low at } 3\text{ mA}) - (V_{Sx} \text{ input high max})$ for I <sup>2</sup> C applications	100	150		100	mV
$V_{IOrel}$	$V_{CC}$ voltage at which all buses are released	Sx, Sy Tx, Ty	Sx, Sy are low, $V_{CC}$ ramping, voltage on Tx, Ty lowered until released		1		1	V

(1) Typical value is at  $V_{CC} = 5\text{ V}$ ,  $T_A = 25^\circ\text{C}$

(2) See the *Typical Characteristics* section of this data sheet.

(3) The output logic low depends on the sink current.

(4) The input logic threshold is independent of the supply voltage.

(5) The minimum value requirement for pullup current, 200 μA, ensures that the minimum value for  $V_{Sx}$  output low always exceeds the minimum  $V_{Sx}$  input high level to eliminate any possibility of latching. The specified difference is specified by design within any device. While the tolerances on absolute levels allow a small probability that the low from one Sx output is recognized by an Sx input of another P82B96, this has no consequences for normal applications.

**Electrical Characteristics:  $V_{CC} = 4.5\text{ V to }5.5\text{ V}$  (continued)**
 $V_{CC} = 4.5\text{ V to }5.5\text{ V}$ , voltages are specified with respect to GND (unless otherwise noted)

PARAMETER		TEST CONDITIONS	$T_A = 25^\circ\text{C}$			$T_A = -40^\circ\text{C to }85^\circ\text{C}$		UNIT
			MIN	TYP <sup>(1)</sup>	MAX	MIN	MAX	
$\Delta V/\Delta T_{REL}$	Temperature coefficient of release voltage			-4				mV/°C
$C_{in}$	Input capacitance	Rx, Ry		2.5	4		4	pF

**7.8 Electrical Characteristics:  $V_{CC} = 15\text{ V}$** 
 $V_{CC} = 15\text{ V}$ , voltages are specified with respect to GND (unless otherwise noted)

PARAMETER		TEST CONDITIONS	$T_A = 25^\circ\text{C}$			$T_A = -40^\circ\text{C to }85^\circ\text{C}$		UNIT
			MIN	TYP <sup>(1)</sup>	MAX	MIN	MAX	
$\Delta V/\Delta T_{IN}$	Temperature coefficient of input thresholds	Sx, Sy		-2				mV/°C
$V_{OL}$	Low-level output voltage	Sx, Sy	$I_{Sx}, I_{Sy} = 3\text{ mA}$	0.8	0.88	1	See <sup>(2)</sup>	V
			$I_{Sx}, I_{Sy} = 0.2\text{ mA}$	0.67	0.73	0.79	See <sup>(2)</sup>	
$\Delta V/\Delta T_{OUT}$	Temperature coefficient of output low levels <sup>(3)</sup>	Sx, Sy	$I_{Sx}, I_{Sy} = 0.2\text{ mA}$		-1.8			mV/°C
$I_{CC}$	Quiescent supply current		$Sx = Sy = V_{CC}$	0.9	1.8		2	mA
$\Delta I_{CC}$	Additional supply current per pin low	Tx, Ty		1.7	2.75		3	mA
$I_{IOS}$	Dynamic output sink capability on I <sup>2</sup> C bus	Sx, Sy	$V_{Sx}, V_{Sy} > 2\text{ V}$ , $V_{Rx}, V_{Ry} = \text{low}$	7	18		6.5	mA
	Leakage current on I <sup>2</sup> C bus		$V_{Sx}, V_{Sy} = 15\text{ V}$ , $V_{Rx}, V_{Ry} = \text{high}$		0.1	1		1
$I_{IOT}$	Dynamic output sink capability on buffered bus	Tx, Ty	$V_{Tx}, V_{Ty} > 1\text{ V}$ , $V_{Sx}, V_{Sy} = \text{low on I}^2\text{C bus}$ $= 0.4\text{ V}$	60	100		60	mA
	Leakage current on buffered bus		$V_{Tx}, V_{Ty} = V_{CC} = 15\text{ V}$ , $V_{Sx}, V_{Sy} = \text{high}$		0.1	1		1
$I_I$	Input current from I <sup>2</sup> C bus	Sx, Sy	Bus low, $V_{Rx}, V_{Ry} = \text{high}$		-1			1
	Input current from buffered bus	Rx, Ry	Bus low, $V_{Rx}, V_{Ry} = 0.4\text{ V}$		-1			1
	Leakage current on buffered bus input		$V_{Rx}, V_{Ry} = V_{CC}$			1		1.5
$V_{IT}$	Input threshold	Sx, Sy	Input logic-level high threshold <sup>(4)</sup> on normal I <sup>2</sup> C bus		0.65	0.7	See <sup>(2)</sup>	V
			Input logic-level high threshold <sup>(4)</sup> on normal I <sup>2</sup> C bus		0.6	0.65	See <sup>(2)</sup>	
		Rx, Ry	Input logic level high		$0.58 \times V_{CC}$		$0.58 \times V_{CC}$	
			Input threshold		$0.5 \times V_{CC}$			
	Input logic level low			$0.42 \times V_{CC}$		$0.42 \times V_{CC}$		

(1) Typical value is at  $V_{CC} = 15\text{ V}$ ,  $T_A = 25^\circ\text{C}$ 

(2) See the [Typical Characteristics](#) section of this data sheet.

(3) The output logic low depends on the sink current.

(4) The input logic threshold is independent of the supply voltage.

### Electrical Characteristics: $V_{CC} = 15\text{ V}$ (continued)

$V_{CC} = 15\text{ V}$ , voltages are specified with respect to GND (unless otherwise noted)

PARAMETER		TEST CONDITIONS	$T_A = 25^\circ\text{C}$			$T_A = -40^\circ\text{C to } 85^\circ\text{C}$		UNIT
			MIN	TYP <sup>(1)</sup>	MAX	MIN	MAX	
$V_{IOdiff}$	Input/output logic level difference <sup>(5)</sup>	Sx, Sy	( $V_{Sx}$ output low at 3 mA) – ( $V_{Sx}$ input high max) for I <sup>2</sup> C applications	100	150		100	mV
$V_{IOrel}$	$V_{CC}$ voltage at which all buses are released	Sx, Sy Tx, Ty	Sx, Sy are low, $V_{CC}$ ramping, voltage on Tx, Ty lowered until released	1			1	V
$\Delta V/\Delta T_{REL}$	Temperature coefficient of release voltage				–4			mV/°C
$C_{in}$	Input capacitance	Rx, Ry		2.5	4		4	pF

- (5) The minimum value requirement for pullup current, 200  $\mu\text{A}$ , ensures that the minimum value for  $V_{Sx}$  output low always exceeds the minimum  $V_{Sx}$  input high level to eliminate any possibility of latching. The specified difference is specified by design within any device. While the tolerances on absolute levels allow a small probability that the low from one Sx output is recognized by an Sx input of another P82B96, this has no consequences for normal applications.

### 7.9 Switching Characteristics

$V_{CC} = 5\text{ V}$ ,  $T_A = 25^\circ\text{C}$ , no capacitive loads, voltages are specified with respect to GND (unless otherwise noted)

PARAMETER	FROM (INPUT)	TO (OUTPUT)	TEST CONDITIONS	TYP	UNIT
$t_{pzi}$	Buffer delay time on falling input	$V_{Sx}$ (or $V_{Sy}$ ) = input switching threshold	$V_{Tx}$ (or $V_{Ty}$ ) output falling 50% of $V_{LOAD}$ <sup>(1)</sup>	70	ns
$t_{plz}$	Buffer delay time on rising input	$V_{Sx}$ (or $V_{Sy}$ ) = input switching threshold	$V_{Tx}$ (or $V_{Ty}$ ) output reaching 50% of $V_{LOAD}$ <sup>(2)</sup>	90	ns
$t_{pzi}$	Buffer delay time on falling input	$V_{Rx}$ (or $V_{Ry}$ ) = input switching threshold	$V_{Sx}$ (or $V_{Sy}$ ) output falling 50% of $V_{LOAD}$ <sup>(3)</sup>	250	ns
$t_{plz}$	Buffer delay time on rising input	$V_{Rx}$ (or $V_{Ry}$ ) = input switching threshold	$V_{Sx}$ (or $V_{Sy}$ ) output reaching 50% of $V_{LOAD}$ <sup>(4)</sup>	270	ns

- (1) The fall time of  $V_{Tx}$  from 5 V to 2.5 V in the test is approximately 15 ns.  
 (2) The rise time of  $V_{Tx}$  from 0 V to 2.5 V in the test is approximately 20 ns.  
 (3) The fall time of  $V_{Sx}$  from 5 V to 2.5 V in the test is approximately 50 ns.  
 (4) The rise time of  $V_{Sx}$  from 0.9 V to 2.5 V in the test is approximately 70 ns.

### 7.10 Typical Characteristics

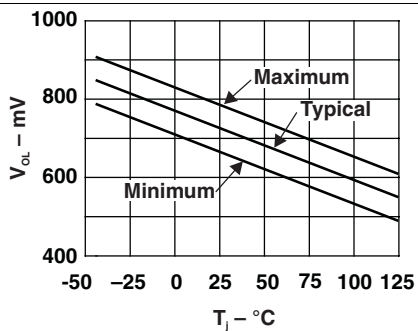

Figure 1.  $V_{OL}$  at Sx vs Junction Temperature,  $I_{OL} = 0.2$  mA

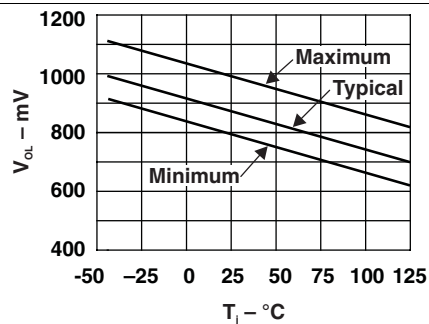

Figure 2.  $V_{OL}$  at Sx vs Junction Temperature,  $I_{OL} = 3$  mA

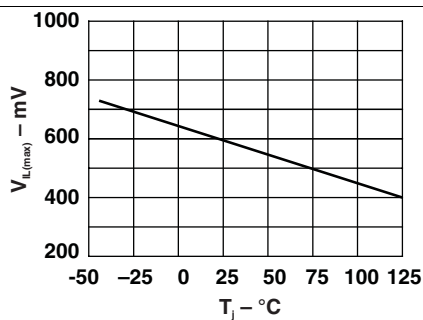

Figure 3.  $V_{IL(max)}$  at Sx vs Junction Temperature

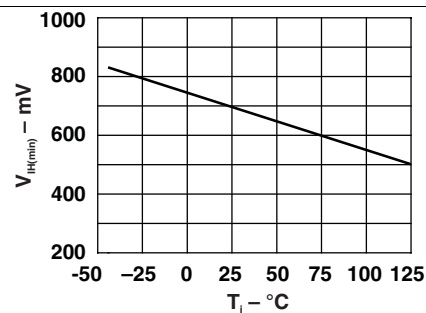

Figure 4.  $V_{IH(min)}$  at Sx vs Junction Temperature

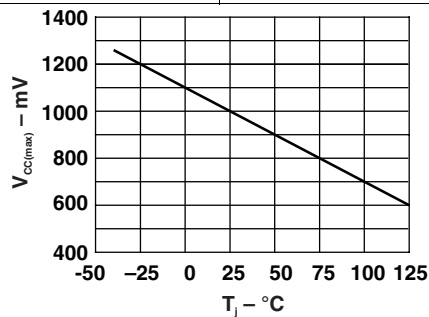
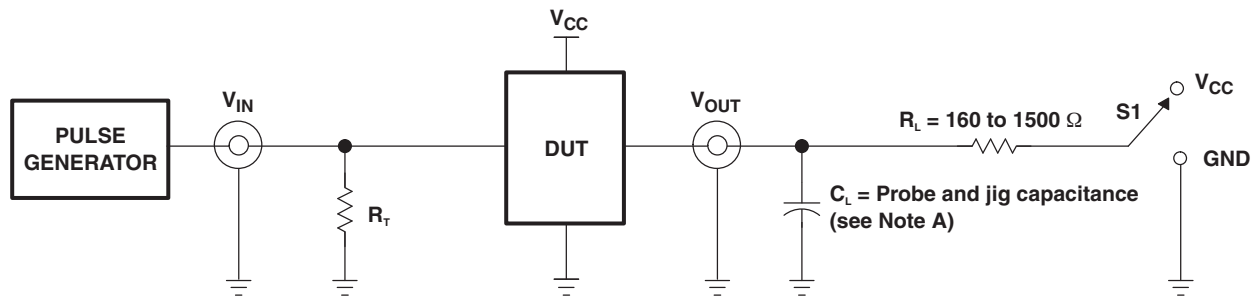

Figure 5.  $V_{CC(max)}$  vs Junction Temperature

## 8 Parameter Measurement Information



TEST	S1
$t_{PLZ}/t_{PZL}$	$V_{CC}$

TEST CIRCUIT FOR OPEN-DRAIN OUTPUT

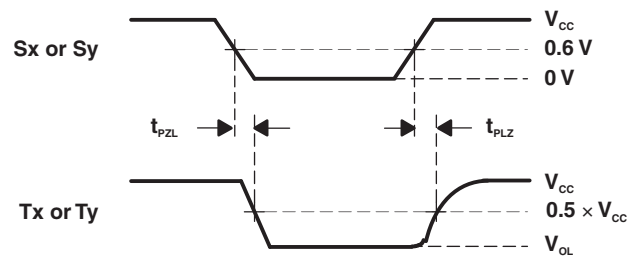

VOLTAGE WAVEFORMS  
PROPAGATION DELAY AND OUTPUT TRANSITION TIMES

- A.  $C_L$  includes probe and jig capacitance.
- B. All inputs are supplied by generators having the following characteristics:  $PRR \leq 10 \text{ MHz}$ ,  $Z_O = 50 \Omega$ ,  $t_r/t_f \leq 30 \text{ ns}$ .

Figure 6. Test Circuit and Voltage Waveforms

## 9 Detailed Description

### 9.1 Overview

The P82B96 is a bus buffer that supports bidirectional data transfer between an I<sup>2</sup>C bus and a range of other bus configurations with different voltage and current levels.

One of the advantages of the P82B96 is that it supports longer cables/traces and allows for more devices per I<sup>2</sup>C bus because it can isolate bus capacitance such that the total loading (devices and trace lengths) of the new bus or remote I<sup>2</sup>C nodes are not apparent to other I<sup>2</sup>C buses (or nodes). The restrictions on the number of I<sup>2</sup>C devices in a system due to capacitance, or the physical separation between them, are greatly improved.

The P82B96 is able to provide galvanic isolation (optocoupling) or use balanced transmission lines (twisted pairs), because separate directional Tx and Rx signals are provided. The Tx and Rx signals may be connected directly (without causing bus latching), to provide an bidirectional signal line with I<sup>2</sup>C properties (open-drain driver). Likewise, the Ty and Ry signals may also be connected together to provide an bidirectional signal line with I<sup>2</sup>C properties (open-drain driver). This allows for a simple communication design, saving design time and costs.

Two or more Sx or Sy I/Os must not be connected to each other on the same node. The P82B96 design does not support this configuration. Bidirectional I<sup>2</sup>C signals do not have a direction control pin so, instead, slightly different logic low-voltage levels are used at Sx/Sy to avoid latching of this buffer. A standard I<sup>2</sup>C low applied at the Rx/Ry of a P82B96 is propagated to Sx/Sy as a buffered low with a slightly higher voltage level. If this special buffered low is applied to the Sx/Sy of another P82B96, the second P82B96 does not recognize it as a standard I<sup>2</sup>C bus low and does not propagate it to its Tx/Ty output. The Sx/Sy side of P82B96 may not be connected to similar buffers that rely on special logic thresholds for their operation.

The Sx/Sy side of the P82B96 is intended for I<sup>2</sup>C logic voltage levels of I<sup>2</sup>C master and slave devices or Tx/Rx signals of a second P82B96, if required. If Rx and Tx are connected, Sx can function as either the SDA or SCL line. Similarly, if Ry and Ty are connected, Sy can function as either the SDA or SCL line. There are no restrictions on the interconnection of the Tx/Rx and Ty/Ry I/O pins to other P82B96s, for example in a star or multi-point configuration (multiple P82B96 devices share the same Tx/Rx and Ty/Ry nodes) with the Tx/Rx and Ty/Ry I/O pins on the common bus, and the Sx/Sy side connected to the line-card slave devices.

In any design, the Sx pins of different devices should never be linked, because the resulting system would be very susceptible to induced noise and would not support all I<sup>2</sup>C operating modes.

### 9.2 Functional Block Diagram

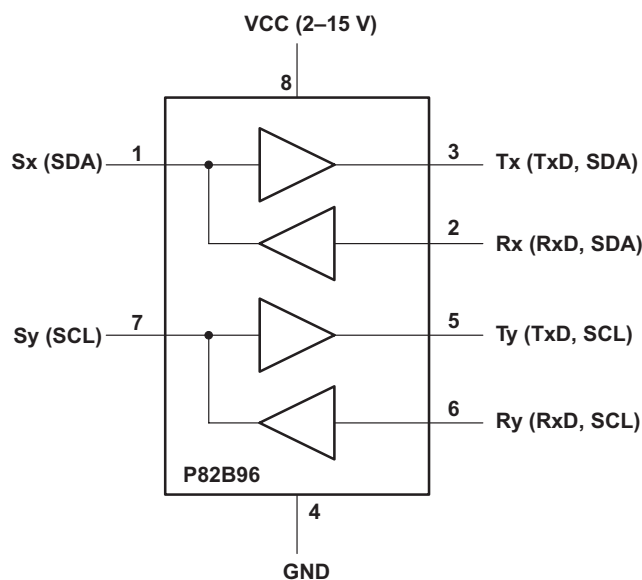

## 9.3 Feature Description

### 9.3.1 Sx and Sy

The I<sup>2</sup>C pins, Sx and Sy, are designed to interface directly with an I<sup>2</sup>C bus. The logic threshold-voltage levels on the I<sup>2</sup>C bus are independent of the supply V<sub>CC</sub>. The maximum I<sup>2</sup>C bus supply voltage is 15 V, and the specified static sink current is 3 mA.

Sx and Sy have two identical buffers. Each buffer is made up of two logic signal paths. The first one, named Tx or Ty, is a forward path from the I<sup>2</sup>C interface pin, which drives the buffered bus. The second one, named Rx or Ry, is a reverse signal path from the buffered bus input to drive the I<sup>2</sup>C bus interface.

There are two purposes for these paths: to sense the voltage state of the I<sup>2</sup>C pin (Sx or Sy) and transmit this state to Tx or Ty, respectively, and to detect the state of the Rx or Ry and pull the I<sup>2</sup>C pin low when Rx or Ry is low.

### 9.3.2 Tx and Ty

Tx and Ty are open-collector outputs without ESD protection diodes to V<sub>CC</sub>. Each pin may be connected through a pullup resistor to a supply voltage in excess of V<sub>CC</sub>, as long as the 15-V rating is not exceeded. Tx and Ty have a larger current-sinking capability than a standard I<sup>2</sup>C device and can sink a static current of greater than 30 mA. They also have dynamic pulldown capability of 100-mA, typically.

A logic low is transmitted to Tx or Ty only when the voltage at the I<sup>2</sup>C pin (Sx or Sy) is less than 0.6 V. A logic low at Rx or Ry causes the I<sup>2</sup>C bus (Sx or Sy) to be pulled to a logic low level in accordance with I<sup>2</sup>C requirements (maximum 1.5 V in 5-V applications), but not low enough to be looped back to the Tx or Ty output and cause the buffer to latch low.

The minimum low level that the P82B96 can achieve on the I<sup>2</sup>C bus by a low at Rx or Ry typically is 0.8 V.

If V<sub>CC</sub> fails, neither the I<sup>2</sup>C pins nor the Tx or Ty outputs are held low. Their open-collector configuration allows them to be pulled up to the rated maximum of 15 V without V<sub>CC</sub> present. The input configuration on Sx, Sy, Rx, and Ry also presents no loading of external signals when V<sub>CC</sub> is not present. This ensures that communication on the main I<sup>2</sup>C bus can continue if the P82B96 has no supply.

The effective input capacitance of any signal pin, measured by its effect on bus rise times, is less than 4 pF for all bus voltages and supply voltages, including V<sub>CC</sub> = 0 V.

### 9.3.3 Long Cable Length

The P82B96 supports 400 pF on the main I2C bus (Sx/Sy side) and up to 4000 pF on the transmission side (Tx/Ty). This allows for longer cables to be used due to the significant increase in capacitance allowed by the device.

## 9.4 Device Functional Modes

The P82B96 begins functioning once V<sub>CC</sub> reaches 2 V. When V<sub>CC</sub> is low, the P82B96 does not hold the Sx/Sy pins low, which ensures I<sup>2</sup>C communication can continue between other devices on the bus while the V<sub>CC</sub> is low.

## 10 Application and Implementation

### NOTE

Information in the following applications sections is not part of the TI component specification, and TI does not warrant its accuracy or completeness. TI's customers are responsible for determining suitability of components for their purposes. Customers should validate and test their design implementation to confirm system functionality.

### 10.1 Application Information

#### 10.1.1 Calculating System Delays and Bus-Clock Frequency for Fast Mode System

Figure 7 through Figure 9 show the P82B96 used to drive extended bus wiring, with relatively large capacitance (up to 4000 pF), linking two Fast mode I<sup>2</sup>C bus nodes. It includes simplified expressions for making the relevant timing calculations for 3.3-/5-V operation. It may be necessary to decrease the nominal SCL frequency below 400 kHz, because the buffers and the wiring introduce timing delays. In most cases, the actual bus frequency is lower than the nominal master timing, due to bit-wise stretching of the clock periods.

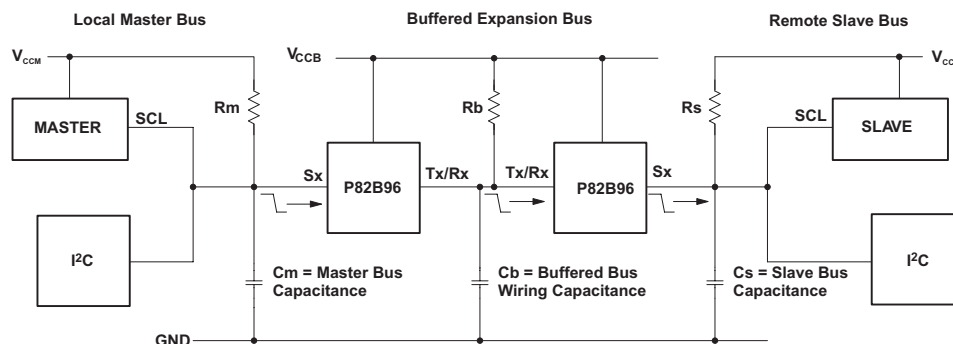

Falling edge of SCL at master is delayed by the buffers and bus fall times.  
Effective Delay of SCL at Slave =  $255 + 17 V_{CCM} + (2.5 + 4 \times 10^6 C_b) V_{CCB}$  (ns)  
C = F, V = Volts

Figure 7. Linking Two I<sup>2</sup>C Bus Nodes Over a Long Cable, Master to Slave

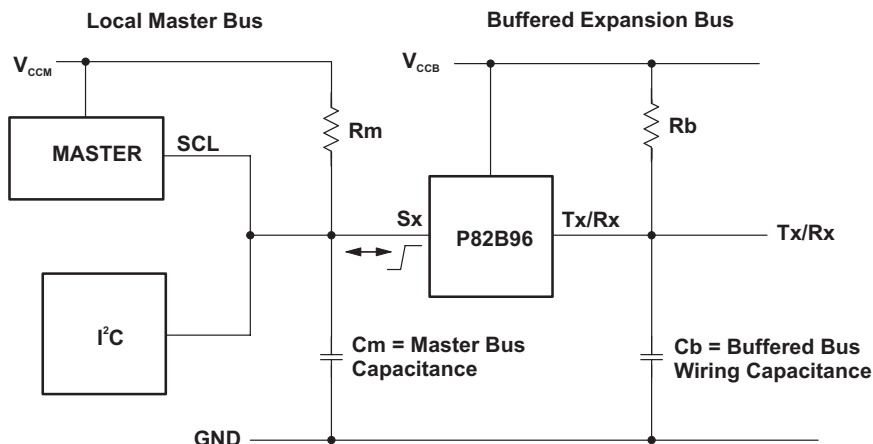

Rising edge of SCL at master is delayed (clock stretch) by buffer and bus rise times.  
Effective delay of SCL at master =  $270 + R_m C_m + 0.7 R_b C_b$  (ns)  
C = F, R = Ω

Figure 8. Master I<sup>2</sup>C Node Connection to P82B96

**Application Information (continued)**

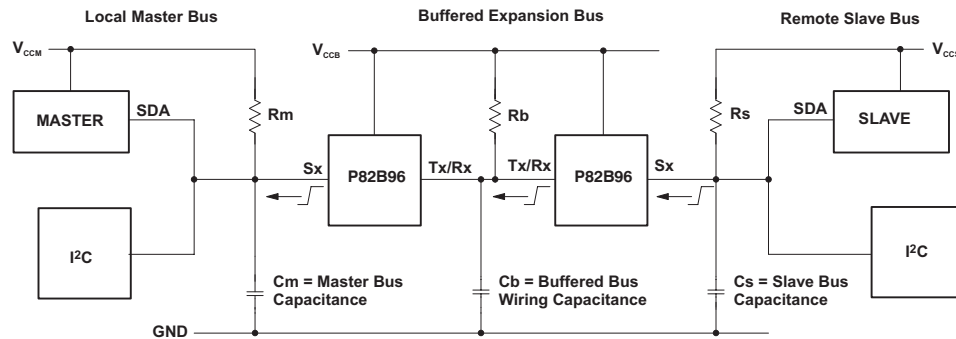

Rising edge of SDA at slave is delayed by the buffers and bus rise times.  
 Effective delay of SDA at master =  $270 + 0.2R_sC_s + 0.7(R_bC_b + R_mC_m)$  (ns)  
 $C = F, R = \Omega$

**Figure 9. Linking Two I<sup>2</sup>C Bus Nodes Over a Long Cable, Slave to Master**

The delay factors involved in calculation of the allowed bus speed are:

- The propagation delay of the master signal through the buffers and wiring to the slave. The important delay is that of the falling edge of SCL, because this edge requests the data or ACK from a slave.
- The effective stretching of the nominal low period of SCL at the master, caused by the buffer and bus rise times.
- The propagation delay of the slave response signal through the buffers and wiring back to the master. The important delay is that of a rising edge in the SDA signal. Rising edges always are slower and, therefore, are delayed by a longer time than falling edges. (The rising edges are limited by the passive pullup, while falling edges actively are driven.)

The timing requirement in any I<sup>2</sup>C system is that a slave's data response (which is provided in response to a falling edge of SCL) must be received at the master before the end of the corresponding low period of SCL as it appears on the bus wiring at the master. Because all slaves, as a minimum, satisfy the worst-case timing requirements of a 400-kHz part, they must provide their response within the minimum allowed clock low period of 1300 ns. Therefore, in systems that introduce additional delays, it is necessary only to extend that minimum clock low period by any effective delay of the slave response. The effective delay of the slave's response equals the total delays in SCL falling edge from the master reaching the slave (A) minus the effective delay (stretch) of the SCL rising edge (B) plus total delays in the slave response data, carried on SDA, and reaching the master (C).

The master microcontroller should be programmed to produce a nominal SCL low period of  $(1300 + A - B + C)$  ns and should be programmed to produce the nominal minimum SCL high period of 600 ns. Then, a check should be made to ensure the cycle time is not shorter than the minimum 2500 ns. If found to be necessary, increase either clock period.

Due to clock stretching, the SCL cycle time always is longer than  $(600 + 1300 + A + C)$  ns.

**10.1.1.1 Sample Calculations**

The master bus has an  $R_mC_m$  product of 100 ns and  $V_{CCM} = 5$  V.

The buffered bus has a capacitance of 1 nF and a pullup resistor of 160  $\Omega$  to 5 V, giving an  $R_bC_b$  product of 160 ns. The slave bus also has an  $R_sC_s$  product of 100 ns.

The master low period should be programmed to be  $\geq(1300 + 372.5 - 482 + 472)$  ns, which calculates to  $\geq 1662.5$  ns.

The master high period may be programmed to the minimum 600 ns. The nominal master clock period is  $\geq(1662.5 + 600)$  ns = 2262.5 ns, equivalent to a frequency of 442 kHz.

The actual bus-clock period, including the 482-ns clock stretch effect, is below (nominal + stretch) =  $(2262.5 + 482)$  ns or  $\geq 2745$  ns, equivalent to an allowable frequency of 364 kHz.

## 10.2 Typical Applications

### 10.2.1 Driving Ribbon or Flat Telephone Cables

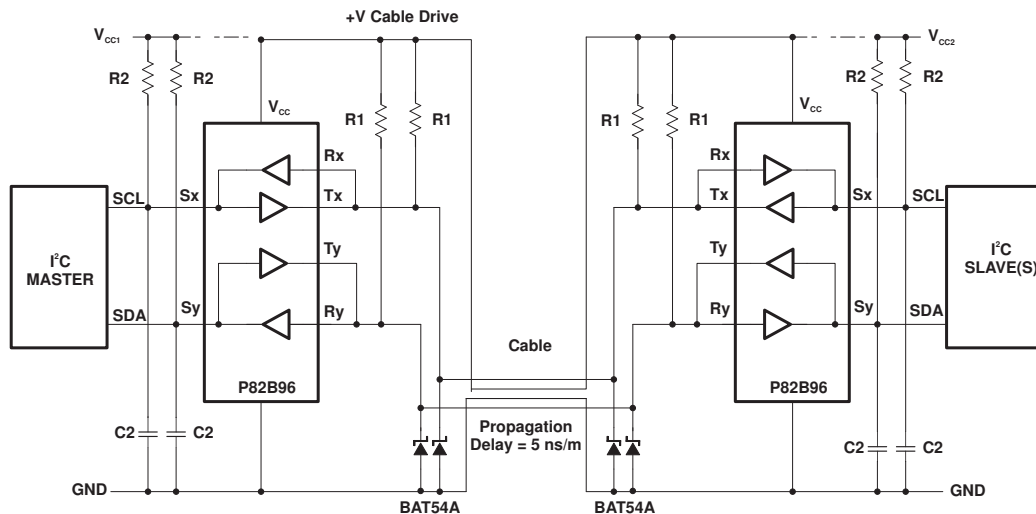

Figure 10. Driving Ribbon or Flat Telephone Cables

#### 10.2.1.1 Design Requirements

In this application, the P82B96 is used to drive a ribbon cable. The following are assumed to be true

- Sy/Sx side of I<sup>2</sup>C bus is at a known voltage from 3.3 V to 5 V
- Tx/Ty and Rx/Ry side of I<sup>2</sup>C bus is at a known voltage from 2 V to 15V
- SCL Clock Speed <= 400kHz

#### 10.2.1.2 Detailed Design Procedure

Table 1. Bus Capabilities

V <sub>CC1</sub> (V)	+V CABLE (V)	V <sub>CC2</sub> (V)	R1 (Ω)	R2 (kΩ)	C2 (pF)	CABLE LENGTH (m)	CABLE CAPACITANCE	CABLE DELAY (ns)	MASTER SCL PULSE DURATION (ns)		BUS CLOCK SPEED (kHz)	MAXIMUM SLAVE RESPONSE DELAY
									HIGH	LOW		
5	12	5	750	2.2	400	250	(1)	1250	600	4000	120	(2)
5	12	5	750	2.2	220	100	(1)	500	600	2600	185	(2)
3.3	5	3.3	330	1	220	25	1 nF	125	600	1500	390	(2)
3.3	5	3.3	330	1	100	3	120 pF	15	600	1000	500	600 ns

(1) Not applicable; calculations are delay based.

(2) Normal 400-kHz bus specification

When the master SCL high and low periods can be programmed separately, the timings can allow for bus delays. The low period should be programmed to achieve the minimum 1300 ns plus the net delay in the slave response data signal caused by bus and buffer delays. The longest data delay is the sum of the delay of the falling edge of SCL from master to slave and the delay of the rising edge of SDA from slave data to master. The actual SCL frequency is lower than calculated from the programmed clock periods because the buffer stretches the programmed SCL low period. In the example for the 25-m cable in Table 1, the clock is stretched 400 ns, the falling edge of SCL is delayed 490 ns, and the SDA rising edge is delayed 570 ns. The required additional low period is (490 + 570) = 1060 ns and the I<sup>2</sup>C bus specifications already include an allowance for a worst-case bus rise time (0% to 70%) of 425 ns. The bus rise time can be 300 ns (30% to 70%), which means it can be 425 ns (0% to 70%). The 25-m cable delay times include all rise and fall times. Therefore, the device only needs to be programmed with an additional (1060 – 400 – 425) = 235 ns, making a total programmed low period 1535 ns. The programmed low is stretched by 400 ns to yield an actual bus low time of 1935 ns, which, allowing the minimum high period of 600 ns, yields a cycle period of 2535 ns or 394 kHz.

Note in both the 100-m and 250-m examples, the capacitive loading on the I<sup>2</sup>C buses at each end is within the maximum allowed Standard mode loading of 400 pF, but exceeds the Fast mode limit. This is an example of a hybrid mode, because it relies on the response delays of Fast mode parts, but uses (allowable) Standard mode bus loadings with rise times that contribute significantly to the system delays. The cables cause large propagation delays. Therefore, these systems must operate well below the 400-kHz limit, but illustrate how they still can exceed the 100-kHz limit, provided all parts are capable of Fast mode operation. The fastest example illustrates how the 400-kHz limit can be exceeded, provided master and slave parts have delay specifications smaller than the maximum allowed. Many TI slaves have delays shorter than 600 ns, but none have that specified.

### 10.2.1.3 Application Curve

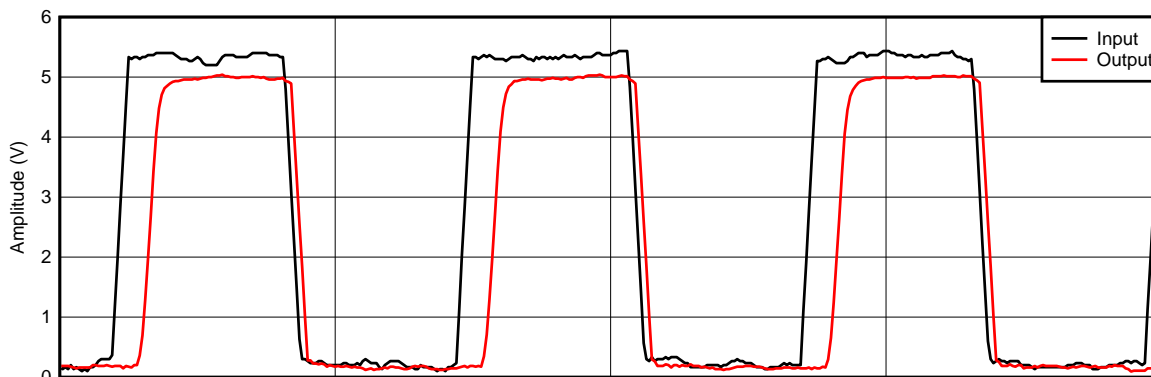

D001

**Figure 11. Propagation Delay Through P82B96 With 400-KHz Data**

### 10.2.2 Galvanic Isolation

Figure 12 shows how the P82B96 can be used to galvanically isolate an I<sup>2</sup>C bus. This is achieved with the use of optocouplers to provide the isolation, and wiring the Rx/Ry and Tx/Ty pins to the appropriate diodes to allow for bidirectional operation.

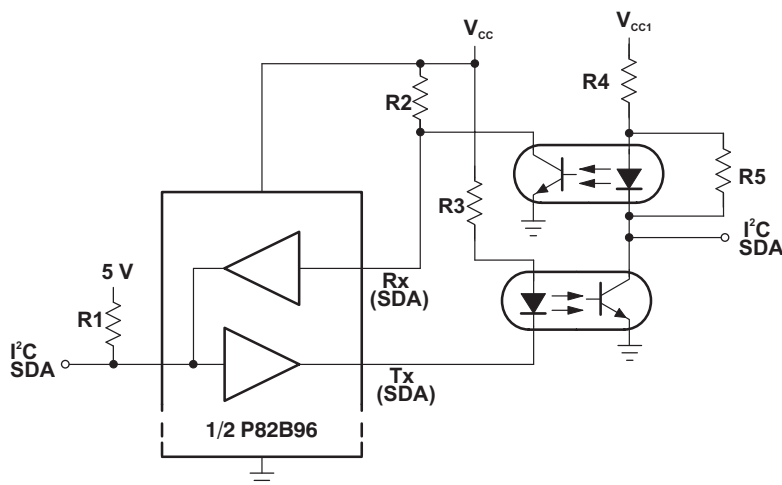

**Figure 12. Galvanic Isolation of I<sup>2</sup>C Nodes**

### 10.2.3 Long-Distance I<sup>2</sup>C

Figure 13 shows how the P82B96 can be used for long-distance I<sup>2</sup>C communications over a twisted pair. Tx and Rx share the same node and connect to one wire of a twisted pair, and Ty and Ry share the same node and connect to another twisted pair. One twisted pair should have 1 wire tied to V<sub>CC</sub> and the other twisted pair should have one of the wires tied to GND.

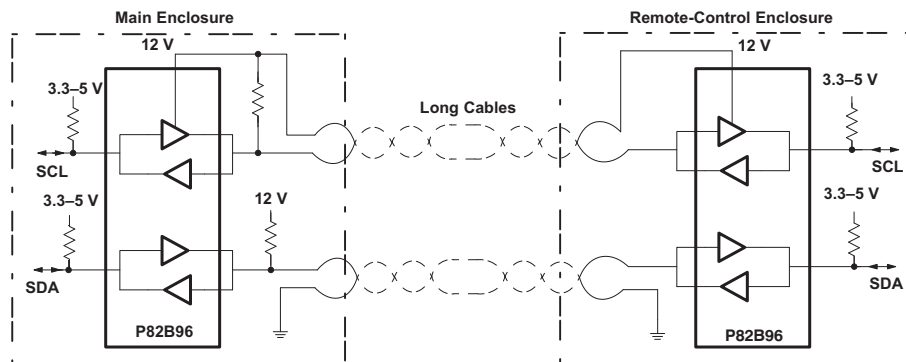

Figure 13. Long-Distance I<sup>2</sup>C Communications

### 10.2.4 Extend I<sup>2</sup>C/DDC Bus With Short-Circuit Protection

Figure 14 shows how a master I<sup>2</sup>C bus can be protected against short circuits or failures in applications that involve plug/socket connections and long cables that may become damaged. A simple circuit is added to monitor the SDA bus and, if its low time exceeds the design value, disconnect the master bus. P82B96 frees all of its I/Os if its supply is removed, so one option is to connect its V<sub>CC</sub> to the output of a logic gate from, for example, the LVC family. The SDA and SCL lines could be timed, and V<sub>CC</sub> disabled through the gate, if a line exceeds a design value of the low period. If the supply voltage of logic gates restricts the choice of V<sub>CC</sub> supply, the low-cost discrete circuit in Figure 14 can be used. If the SDA line is held low, the 100-nF capacitor charges, and Ry is pulled toward V<sub>CC</sub>. When it exceeds V<sub>CC</sub>/2, Ry sets Sy high, which effectively releases it.

In this example, the SCL line is made unidirectional by tying Rx to V<sub>CC</sub>. The state of the buffered SCL line cannot affect the master clock line, which is allowed when clock stretching is not required. It is simple to add an additional transistor or diode to control the Rx input in the same way as Ry, when necessary. The +V cable drive can be any voltage up to 15 V, and the bus may be run at a lower impedance by selecting pullup resistors for a static sink current up to 30 mA. V<sub>CC1</sub> and V<sub>CC2</sub> may be chosen to suit the connected devices. Because DDC uses relatively low speeds (<100 kHz), the cable length is not restricted to 20 m by the I<sup>2</sup>C signaling, but it may be limited by the video signaling.

Figure 10 and Table 1 show that P82B96 can achieve high clock rates over long cables. While calculating with lumped wiring capacitance yields reasonable approximations to actual timing; even 25 m of cable is better treated using transmission line theory. Flat ribbon cables connected as shown, with the bus signals on the outer edge, have a characteristic impedance in the range 100–200 Ω. For simplicity, they cannot be terminated in their characteristic impedance, but a practical compromise is to use the minimum pullup allowed for P82B96 and place half this termination at each end of the cable. When each pullup is less than 330 Ω, the rising-edge waveforms have their first voltage step level above the logic threshold at Rx, and cable timing calculations can be based on the fast rise/fall times of resistive loading, plus simple one-way propagation delays. When the pullup is larger, but less than 750 Ω, the threshold at Rx is crossed after one signal reflection. So, at the sending end, it is crossed after two times the one-way propagation delay and, at the receiving end, after three times that propagation delay. For flat cables with partial plastic dielectric insulation (by using outer cores) the one-way propagation delays are about 5 ns/m. The 10% to 90% rise and fall times on the cable are from 20 ns and 50 ns, so their delay contributions are small. There is ringing on falling edges that can be damped, if required, using Schottky diodes.

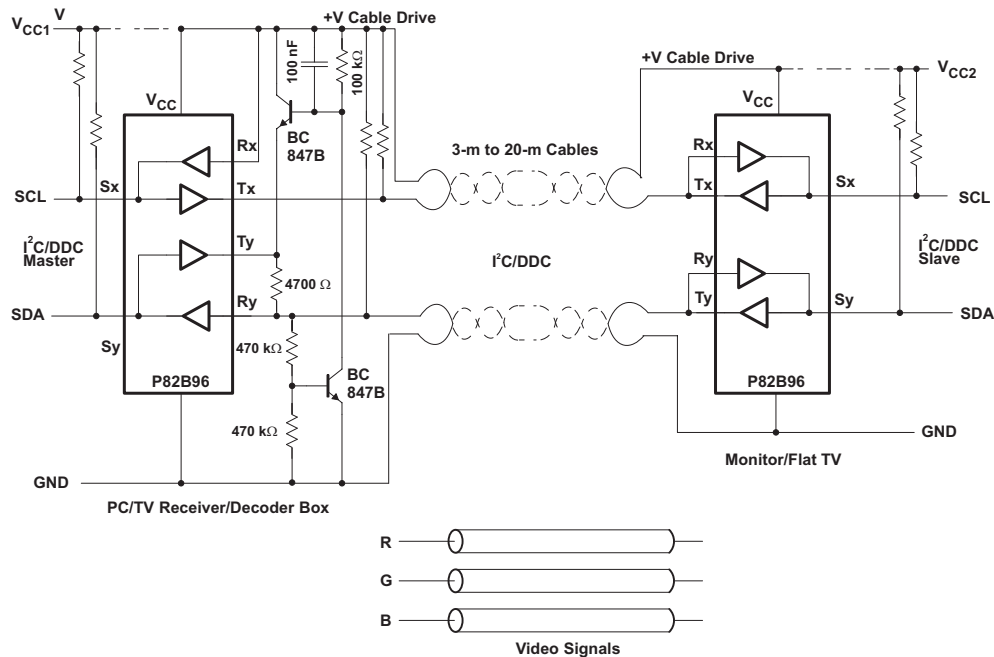

Figure 14. Extending DDC Bus

### 10.2.5 Voltage Translation

Figure 15 shows how the P82B96 can be used for I<sup>2</sup>C Voltage Translation.

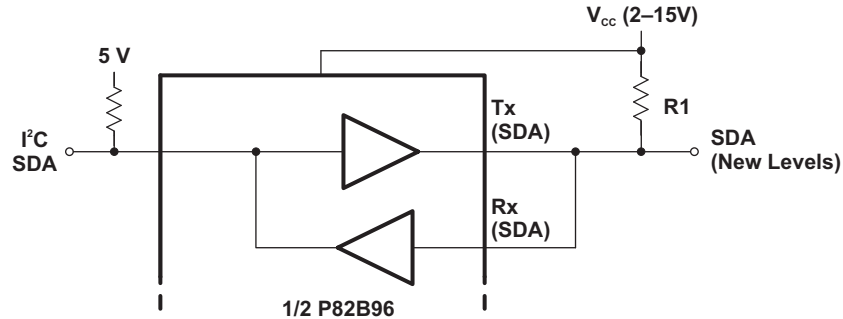

Figure 15. Interfacing I<sup>2</sup>C Bus With Different Logic Levels

## 11 Power Supply Recommendations

VCC accepts supply voltages from 2 V up to 15 V. The GND pin must be tied to ground. TI recommends that decoupling capacitor with a value of approximately 100 nF be placed near VCC.

## 12 Layout

### 12.1 Layout Guidelines

The recommended decoupling capacitors should be placed as close to the VCC pin of the P82B96 as possible.

### 12.2 Layout Example

Figure 16 is an example layout for the typical application seen in the *Long-Distance  $f_c$*  section, using the DGK package.

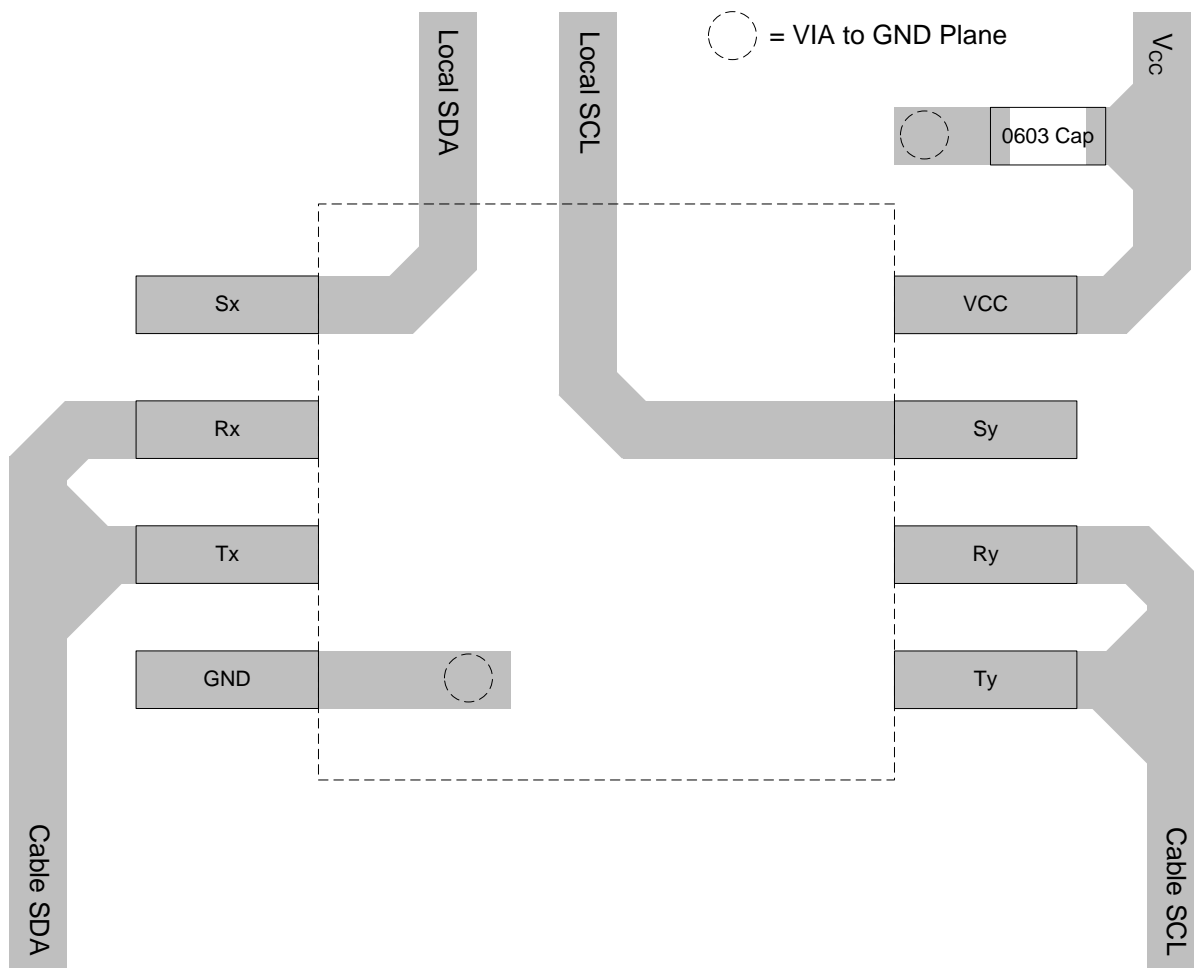

Figure 16. Layout Example

## 13 Device and Documentation Support

### 13.1 Community Resources

The following links connect to TI community resources. Linked contents are provided "AS IS" by the respective contributors. They do not constitute TI specifications and do not necessarily reflect TI's views; see TI's [Terms of Use](#).

**TI E2E™ Online Community** *TI's Engineer-to-Engineer (E2E) Community*. Created to foster collaboration among engineers. At [e2e.ti.com](http://e2e.ti.com), you can ask questions, share knowledge, explore ideas and help solve problems with fellow engineers.

**Design Support** *TI's Design Support* Quickly find helpful E2E forums along with design support tools and contact information for technical support.

### 13.2 Trademarks

E2E is a trademark of Texas Instruments.  
All other trademarks are the property of their respective owners.

### 13.3 Electrostatic Discharge Caution



These devices have limited built-in ESD protection. The leads should be shorted together or the device placed in conductive foam during storage or handling to prevent electrostatic damage to the MOS gates.

### 13.4 Glossary

[SLYZ022](#) — *TI Glossary*.

This glossary lists and explains terms, acronyms, and definitions.

## 14 Mechanical, Packaging, and Orderable Information

The following pages include mechanical, packaging, and orderable information. This information is the most current data available for the designated devices. This data is subject to change without notice and revision of this document. For browser-based versions of this data sheet, refer to the left-hand navigation.

**PACKAGING INFORMATION**

Orderable Device	Status (1)	Package Type	Package Drawing	Pins	Package Qty	Eco Plan (2)	Lead finish/ Ball material (6)	MSL Peak Temp (3)	Op Temp (°C)	Device Marking (4/5)	Samples
P82B96DGKR	ACTIVE	VSSOP	DGK	8	2500	RoHS & Green	NIPDAU	Level-1-260C-UNLIM	-40 to 85	7DS	<a href="#">Samples</a>
P82B96DGKRG4	ACTIVE	VSSOP	DGK	8	2500	RoHS & Green	NIPDAU	Level-1-260C-UNLIM	-40 to 85	7DS	<a href="#">Samples</a>
P82B96DR	ACTIVE	SOIC	D	8	2500	RoHS & Green	NIPDAU	Level-1-260C-UNLIM	-40 to 85	PG96	<a href="#">Samples</a>
P82B96DRG4	ACTIVE	SOIC	D	8	2500	RoHS & Green	NIPDAU	Level-1-260C-UNLIM	-40 to 85	PG96	<a href="#">Samples</a>
P82B96P	ACTIVE	PDIP	P	8	50	RoHS & Green	NIPDAU	N / A for Pkg Type	-40 to 85	P82B96P	<a href="#">Samples</a>
P82B96PWR	ACTIVE	TSSOP	PW	8	2000	RoHS & Green	NIPDAU	Level-1-260C-UNLIM	-40 to 85	PG96	<a href="#">Samples</a>
P82B96PWRG4	ACTIVE	TSSOP	PW	8	2000	RoHS & Green	NIPDAU	Level-1-260C-UNLIM	-40 to 85	PG96	<a href="#">Samples</a>

(1) The marketing status values are defined as follows:

**ACTIVE:** Product device recommended for new designs.

**LIFEBUY:** TI has announced that the device will be discontinued, and a lifetime-buy period is in effect.

**NRND:** Not recommended for new designs. Device is in production to support existing customers, but TI does not recommend using this part in a new design.

**PREVIEW:** Device has been announced but is not in production. Samples may or may not be available.

**OBSOLETE:** TI has discontinued the production of the device.

(2) **RoHS:** TI defines "RoHS" to mean semiconductor products that are compliant with the current EU RoHS requirements for all 10 RoHS substances, including the requirement that RoHS substance do not exceed 0.1% by weight in homogeneous materials. Where designed to be soldered at high temperatures, "RoHS" products are suitable for use in specified lead-free processes. TI may reference these types of products as "Pb-Free".

**RoHS Exempt:** TI defines "RoHS Exempt" to mean products that contain lead but are compliant with EU RoHS pursuant to a specific EU RoHS exemption.

**Green:** TI defines "Green" to mean the content of Chlorine (Cl) and Bromine (Br) based flame retardants meet JS709B low halogen requirements of <=1000ppm threshold. Antimony trioxide based flame retardants must also meet the <=1000ppm threshold requirement.

(3) MSL, Peak Temp. - The Moisture Sensitivity Level rating according to the JEDEC industry standard classifications, and peak solder temperature.

(4) There may be additional marking, which relates to the logo, the lot trace code information, or the environmental category on the device.

(5) Multiple Device Markings will be inside parentheses. Only one Device Marking contained in parentheses and separated by a "~" will appear on a device. If a line is indented then it is a continuation of the previous line and the two combined represent the entire Device Marking for that device.

<sup>(6)</sup> Lead finish/Ball material - Orderable Devices may have multiple material finish options. Finish options are separated by a vertical ruled line. Lead finish/Ball material values may wrap to two lines if the finish value exceeds the maximum column width.

**Important Information and Disclaimer:**The information provided on this page represents TI's knowledge and belief as of the date that it is provided. TI bases its knowledge and belief on information provided by third parties, and makes no representation or warranty as to the accuracy of such information. Efforts are underway to better integrate information from third parties. TI has taken and continues to take reasonable steps to provide representative and accurate information but may not have conducted destructive testing or chemical analysis on incoming materials and chemicals. TI and TI suppliers consider certain information to be proprietary, and thus CAS numbers and other limited information may not be available for release.

In no event shall TI's liability arising out of such information exceed the total purchase price of the TI part(s) at issue in this document sold by TI to Customer on an annual basis.

## TAPE AND REEL INFORMATION



### QUADRANT ASSIGNMENTS FOR PIN 1 ORIENTATION IN TAPE

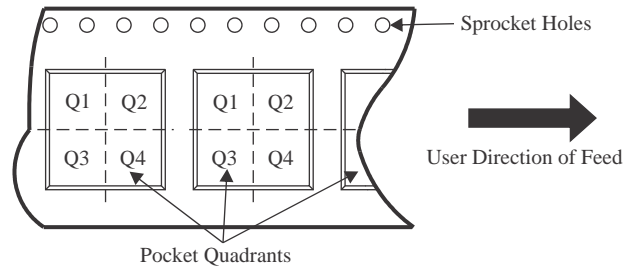

\*All dimensions are nominal

Device	Package Type	Package Drawing	Pins	SPQ	Reel Diameter (mm)	Reel Width W1 (mm)	A0 (mm)	B0 (mm)	K0 (mm)	P1 (mm)	W (mm)	Pin1 Quadrant
P82B96DGKR	VSSOP	DGK	8	2500	330.0	12.4	5.3	3.4	1.4	8.0	12.0	Q1
P82B96DR	SOIC	D	8	2500	330.0	12.4	6.4	5.2	2.1	8.0	12.0	Q1
P82B96PWR	TSSOP	PW	8	2000	330.0	12.4	7.0	3.6	1.6	8.0	12.0	Q1

**TAPE AND REEL BOX DIMENSIONS**

\*All dimensions are nominal

Device	Package Type	Package Drawing	Pins	SPQ	Length (mm)	Width (mm)	Height (mm)
P82B96DGKR	VSSOP	DGK	8	2500	358.0	335.0	35.0
P82B96DR	SOIC	D	8	2500	356.0	356.0	35.0
P82B96PWR	TSSOP	PW	8	2000	356.0	356.0	35.0

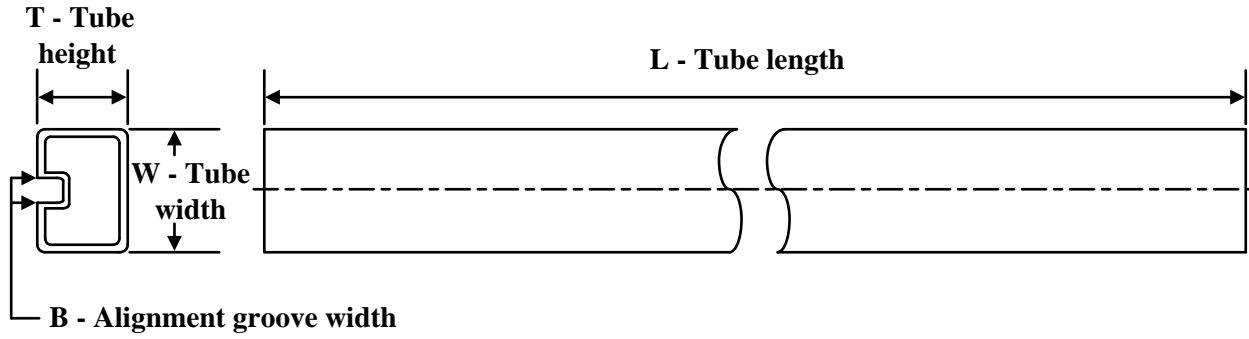
**TUBE**

\*All dimensions are nominal

Device	Package Name	Package Type	Pins	SPQ	L (mm)	W (mm)	T (μm)	B (mm)
P82B96P	P	PDIP	8	50	506	13.97	11230	4.32



D0008A

# PACKAGE OUTLINE

SOIC - 1.75 mm max height

SMALL OUTLINE INTEGRATED CIRCUIT



4214825/C 02/2019

NOTES:

- Linear dimensions are in inches [millimeters]. Dimensions in parenthesis are for reference only. Controlling dimensions are in inches. Dimensioning and tolerancing per ASME Y14.5M.
- This drawing is subject to change without notice.
- This dimension does not include mold flash, protrusions, or gate burrs. Mold flash, protrusions, or gate burrs shall not exceed .006 [0.15] per side.
- This dimension does not include interlead flash.
- Reference JEDEC registration MS-012, variation AA.

# EXAMPLE BOARD LAYOUT

D0008A

SOIC - 1.75 mm max height

SMALL OUTLINE INTEGRATED CIRCUIT



LAND PATTERN EXAMPLE  
EXPOSED METAL SHOWN  
SCALE:8X



SOLDER MASK DETAILS

4214825/C 02/2019

NOTES: (continued)

6. Publication IPC-7351 may have alternate designs.

7. Solder mask tolerances between and around signal pads can vary based on board fabrication site.

# EXAMPLE STENCIL DESIGN

D0008A

SOIC - 1.75 mm max height

SMALL OUTLINE INTEGRATED CIRCUIT



SOLDER PASTE EXAMPLE  
BASED ON .005 INCH [0.125 MM] THICK STENCIL  
SCALE:8X

4214825/C 02/2019

NOTES: (continued)

8. Laser cutting apertures with trapezoidal walls and rounded corners may offer better paste release. IPC-7525 may have alternate design recommendations.
9. Board assembly site may have different recommendations for stencil design.

P (R-PDIP-T8)

PLASTIC DUAL-IN-LINE PACKAGE



- NOTES:
- A. All linear dimensions are in inches (millimeters).
  - B. This drawing is subject to change without notice.
  - C. Falls within JEDEC MS-001 variation BA.

PW0008A



# PACKAGE OUTLINE

## TSSOP - 1.2 mm max height

SMALL OUTLINE PACKAGE

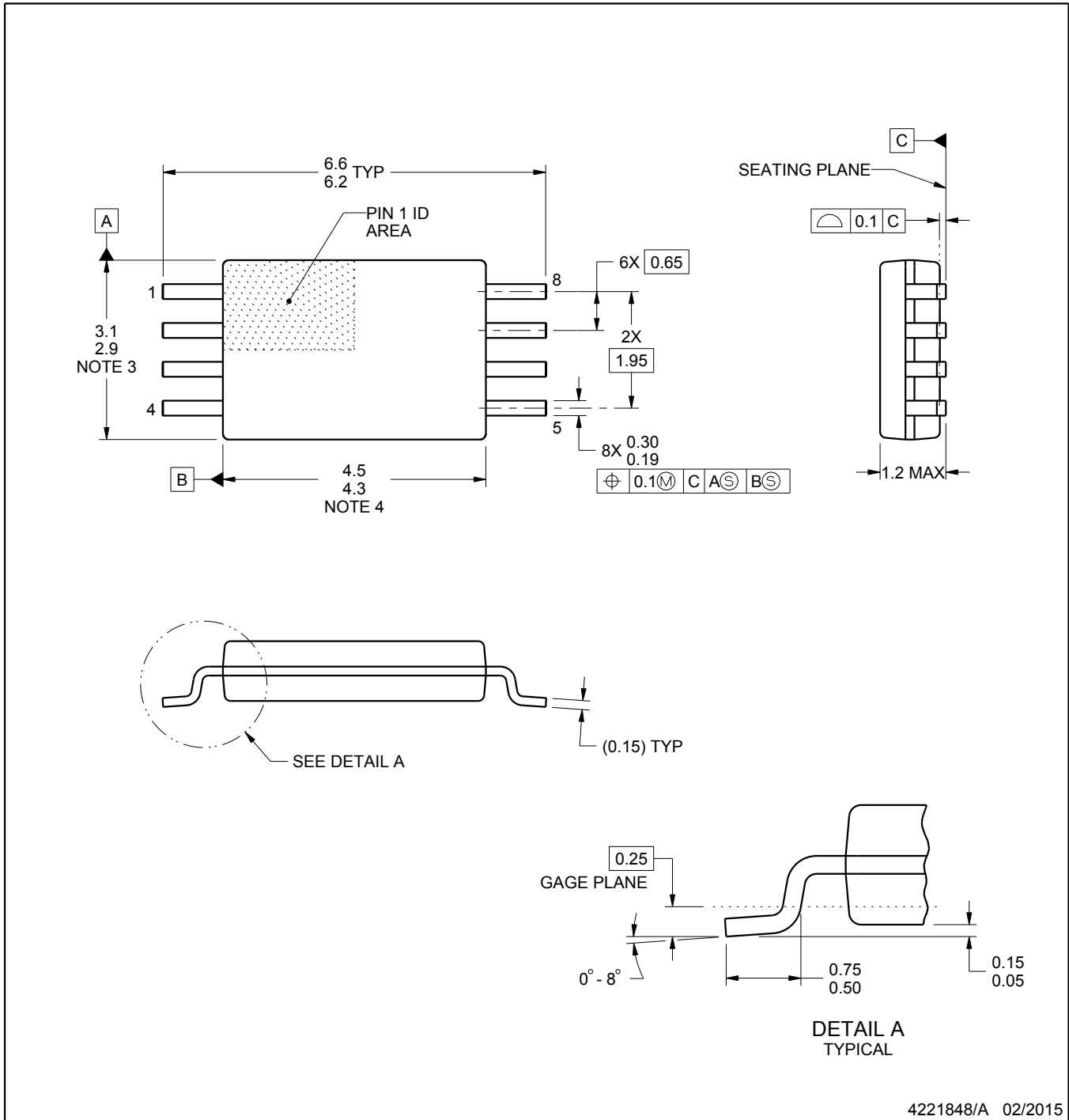

4221848/A 02/2015

NOTES:

1. All linear dimensions are in millimeters. Any dimensions in parenthesis are for reference only. Dimensioning and tolerancing per ASME Y14.5M.
2. This drawing is subject to change without notice.
3. This dimension does not include mold flash, protrusions, or gate burrs. Mold flash, protrusions, or gate burrs shall not exceed 0.15 mm per side.
4. This dimension does not include interlead flash. Interlead flash shall not exceed 0.25 mm per side.
5. Reference JEDEC registration MO-153, variation AA.

# EXAMPLE BOARD LAYOUT

PW0008A

TSSOP - 1.2 mm max height

SMALL OUTLINE PACKAGE



LAND PATTERN EXAMPLE  
SCALE:10X



SOLDER MASK DETAILS  
NOT TO SCALE

4221848/A 02/2015

NOTES: (continued)

- 6. Publication IPC-7351 may have alternate designs.
- 7. Solder mask tolerances between and around signal pads can vary based on board fabrication site.

# EXAMPLE STENCIL DESIGN

PW0008A

TSSOP - 1.2 mm max height

SMALL OUTLINE PACKAGE



SOLDER PASTE EXAMPLE  
BASED ON 0.125 mm THICK STENCIL  
SCALE:10X

4221848/A 02/2015

NOTES: (continued)

8. Laser cutting apertures with trapezoidal walls and rounded corners may offer better paste release. IPC-7525 may have alternate design recommendations.
9. Board assembly site may have different recommendations for stencil design.

# DGK0008A



# PACKAGE OUTLINE

VSSOP - 1.1 mm max height

SMALL OUTLINE PACKAGE



**NOTES:**

PowerPAD is a trademark of Texas Instruments.

1. All linear dimensions are in millimeters. Any dimensions in parenthesis are for reference only. Dimensioning and tolerancing per ASME Y14.5M.
2. This drawing is subject to change without notice.
3. This dimension does not include mold flash, protrusions, or gate burrs. Mold flash, protrusions, or gate burrs shall not exceed 0.15 mm per side.
4. This dimension does not include interlead flash. Interlead flash shall not exceed 0.25 mm per side.
5. Reference JEDEC registration MO-187.

# EXAMPLE BOARD LAYOUT

DGK0008A

™ VSSOP - 1.1 mm max height

SMALL OUTLINE PACKAGE



LAND PATTERN EXAMPLE  
EXPOSED METAL SHOWN  
SCALE: 15X



4214862/A 04/2023

NOTES: (continued)

6. Publication IPC-7351 may have alternate designs.
7. Solder mask tolerances between and around signal pads can vary based on board fabrication site.
8. Vias are optional depending on application, refer to device data sheet. If any vias are implemented, refer to their locations shown on this view. It is recommended that vias under paste be filled, plugged or tented.
9. Size of metal pad may vary due to creepage requirement.

# EXAMPLE STENCIL DESIGN

DGK0008A

<sup>TM</sup> VSSOP - 1.1 mm max height

SMALL OUTLINE PACKAGE



SOLDER PASTE EXAMPLE  
SCALE: 15X

4214862/A 04/2023

NOTES: (continued)

11. Laser cutting apertures with trapezoidal walls and rounded corners may offer better paste release. IPC-7525 may have alternate design recommendations.
12. Board assembly site may have different recommendations for stencil design.

## IMPORTANT NOTICE AND DISCLAIMER

TI PROVIDES TECHNICAL AND RELIABILITY DATA (INCLUDING DATA SHEETS), DESIGN RESOURCES (INCLUDING REFERENCE DESIGNS), APPLICATION OR OTHER DESIGN ADVICE, WEB TOOLS, SAFETY INFORMATION, AND OTHER RESOURCES "AS IS" AND WITH ALL FAULTS, AND DISCLAIMS ALL WARRANTIES, EXPRESS AND IMPLIED, INCLUDING WITHOUT LIMITATION ANY IMPLIED WARRANTIES OF MERCHANTABILITY, FITNESS FOR A PARTICULAR PURPOSE OR NON-INFRINGEMENT OF THIRD PARTY INTELLECTUAL PROPERTY RIGHTS.

These resources are intended for skilled developers designing with TI products. You are solely responsible for (1) selecting the appropriate TI products for your application, (2) designing, validating and testing your application, and (3) ensuring your application meets applicable standards, and any other safety, security, regulatory or other requirements.

These resources are subject to change without notice. TI grants you permission to use these resources only for development of an application that uses the TI products described in the resource. Other reproduction and display of these resources is prohibited. No license is granted to any other TI intellectual property right or to any third party intellectual property right. TI disclaims responsibility for, and you will fully indemnify TI and its representatives against, any claims, damages, costs, losses, and liabilities arising out of your use of these resources.

TI's products are provided subject to [TI's Terms of Sale](#) or other applicable terms available either on [ti.com](https://www.ti.com) or provided in conjunction with such TI products. TI's provision of these resources does not expand or otherwise alter TI's applicable warranties or warranty disclaimers for TI products.

TI objects to and rejects any additional or different terms you may have proposed.

Mailing Address: Texas Instruments, Post Office Box 655303, Dallas, Texas 75265  
Copyright © 2024, Texas Instruments Incorporated

## Looking for pricing, stock, or lifecycle information?

Click below to explore more details on WIN SOURCE:

 [View P82B96DR](#) on WIN SOURCE

 [Texas Instruments](#) Information

## Optimize Your Supply Chain with WIN SOURCE Solutions

-  Global Sourcing Solution
-  Obsolete Management
-  Cost Control Management
-  Shortage Management
-  Alternative Solution
-  Excess Inventory Management