



P89LPC920/921/922/9221

8-bit microcontrollers with two-clock 80C51 core
2 kB/4 kB/8 kB 3 V low-power Flash with 256-byte data RAM

Rev. 08 — 15 December 2004

Product data

1. General description

The P89LPC920/921/922/9221 are single-chip microcontrollers designed for applications demanding high-integration, low cost solutions over a wide range of performance requirements. The P89LPC920/921/922/9221 is based on a high performance processor architecture that executes instructions in two to four clocks, six times the rate of standard 80C51 devices. Many system-level functions have been incorporated into the P89LPC920/921/922/9221 in order to reduce component count, board space, and system cost.

2. Features

2.1 Principal features

- 2 kB/4 kB/8 kB Flash code memory with 1 kB erasable sectors, 64-byte erasable page size, and single byte erase.
- 256-byte RAM data memory.
- Two 16-bit counter/timers. Each timer may be configured to toggle a port output upon timer overflow or to become a PWM output.
- Real-Time clock that can also be used as a system timer.
- Two analog comparators with selectable inputs and reference source.
- Enhanced UART with fractional baud rate generator, break detect, framing error detection, automatic address detection and versatile interrupt capabilities.
- 400 kHz byte-wide I²C-bus communication port.
- Configurable on-chip oscillator with frequency range and RC oscillator options (selected by user programmed Flash configuration bits). The RC oscillator (factory calibrated to $\pm 1\%$) option allows operation without external oscillator components. Oscillator options support frequencies from 20 kHz to the maximum operating frequency of 18 MHz. The RC oscillator option is selectable and fine tunable.
- 2.4 V to 3.6 V V_{DD} operating range. I/O pins are 5 V tolerant (may be pulled up or driven to 5.5 V).
- High drive current (20 mA) on eight I/O pins on the P89LPC9221 (P0.3 to P0.7, P1.4, P1.6, P1.7).



PHILIPS

2.2 Additional features

- 15 I/O pins minimum. Up to 18 I/O pins while using on-chip oscillator and reset options.
- 20-pin TSSOP and DIP packages.
- A high performance 80C51 CPU provides instruction cycle times of 111 ns to 222 ns for all instructions except multiply and divide when executing at 18 MHz. This is six times the performance of the standard 80C51 running at the same clock frequency. A lower clock frequency for the same performance results in power savings and reduced EMI.
- In-Application Programming of the Flash code memory. This allows changing the code in a running application.
- Serial Flash programming allows simple in-circuit production coding. Flash security bits prevent reading of sensitive application programs.
- Watchdog timer with separate on-chip oscillator, requiring no external components. The watchdog prescaler is selectable from eight values.
- Low voltage reset (Brownout detect) allows a graceful system shutdown when power fails. May optionally be configured as an interrupt.
- Idle and two different Power-down reduced power modes. Improved wake-up from Power-down mode (a low interrupt input starts execution). Typical Power-down current is 1 μ A (total Power-down with voltage comparators disabled).
- Active-LOW reset. On-chip power-on reset allows operation without external reset components. A reset counter and reset glitch suppression circuitry prevent spurious and incomplete resets. A software reset function is also available.
- Oscillator Fail Detect. The watchdog timer has a separate fully on-chip oscillator allowing it to perform an oscillator fail detect function.
- Programmable port output configuration options:
 - ◆ quasi-bidirectional,
 - ◆ open drain,
 - ◆ push-pull,
 - ◆ input-only.
- Port 'input pattern match' detect. Port 0 may generate an interrupt when the value of the pins match or do not match a programmable pattern.
- LED drive capability (20 mA) on all port pins. A maximum limit is specified for the entire chip (160 mA for the P89LPC9221; 80 mA for the P89LPC920/921/922).
- Controlled slew rate port outputs to reduce EMI. Outputs have approximately 10 ns minimum ramp times.
- Only power and ground connections are required to operate the P89LPC920/921/922/9221 when internal reset option is selected.
- Four interrupt priority levels.
- Eight keypad interrupt inputs, plus two additional external interrupt inputs.
- Second data pointer.
- Schmitt trigger port inputs.
- Emulation support.

3. Ordering information

Table 1: Ordering information

Type number	Package		
	Name	Description	Version
P89LPC920FDH	TSSOP20	plastic thin shrink small outline package; 20 leads; body width 4.4 mm	SOT360-1
P89LPC921FDH	TSSOP20	plastic thin shrink small outline package; 20 leads; body width 4.4 mm	SOT360-1
P89LPC922FDH	TSSOP20	plastic thin shrink small outline package; 20 leads; body width 4.4 mm	SOT360-1
P89LPC922FN	DIP20	plastic dual in-line package; 20 leads (300 mil)	SOT146-1
P89LPC9221FN	DIP20	plastic dual in-line package; 20 leads (300 mil)	SOT146-1
P89LPC9221FDH	TSSOP20	plastic thin shrink small outline package; 20 leads; body width 4.4 mm	SOT360-1

3.1 Ordering options

Table 2: Part options

Type number	Flash memory	Temperature range	Frequency
P89LPC920FDH	2 kB	-40 °C to +85 °C	0 MHz to 18 MHz
P89LPC921FDH	4 kB	-40 °C to +85 °C	0 MHz to 18 MHz
P89LPC922FDH	8 kB	-40 °C to +85 °C	0 MHz to 18 MHz
P89LPC922FN	8 kB	-40 °C to +85 °C	0 MHz to 18 MHz
P89LPC9221FN	8 kB	-40 °C to +85 °C	0 MHz to 18 MHz
P89LPC9221FDH	8 kB	-40 °C to +85 °C	0 MHz to 18 MHz

4. Block diagram

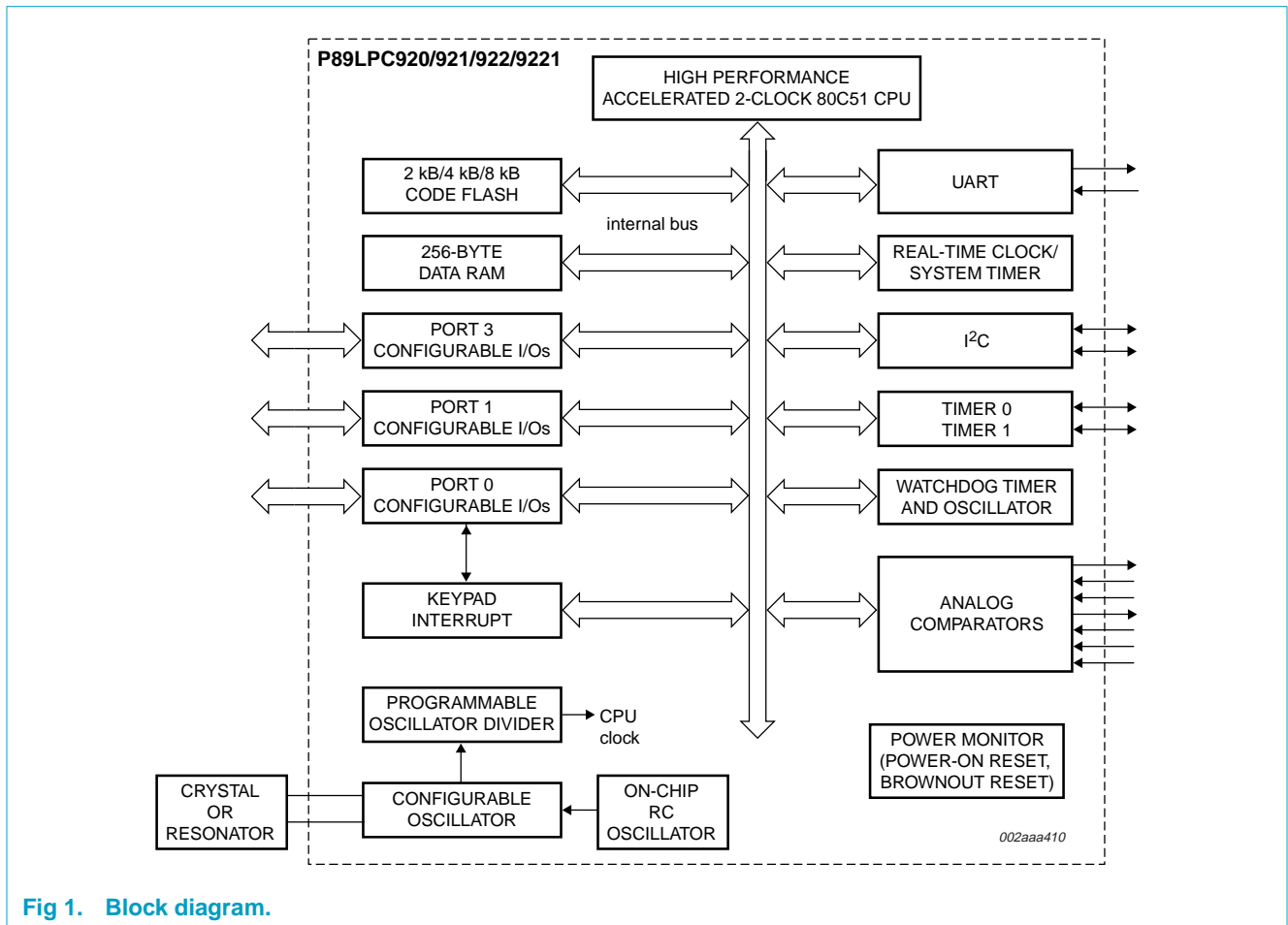
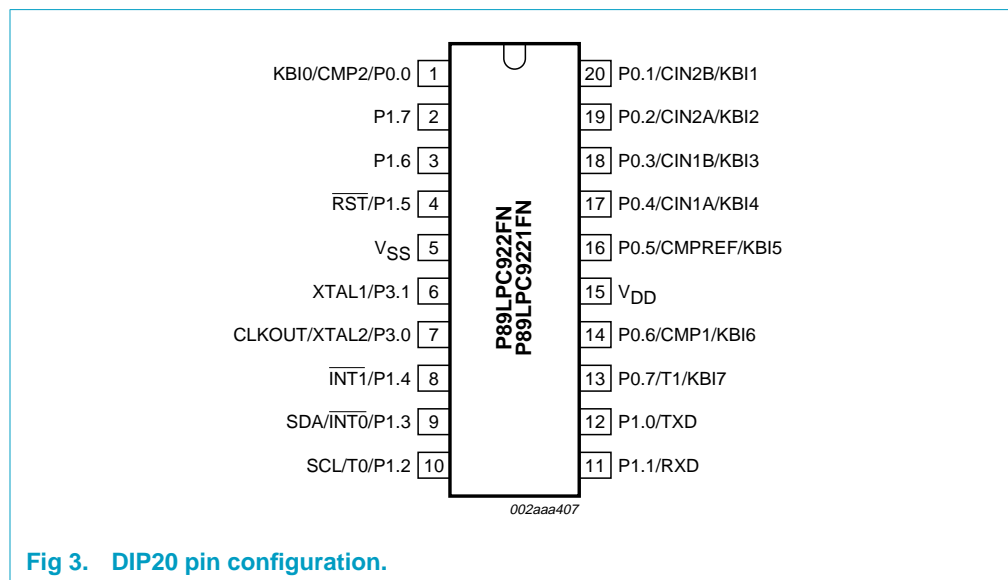
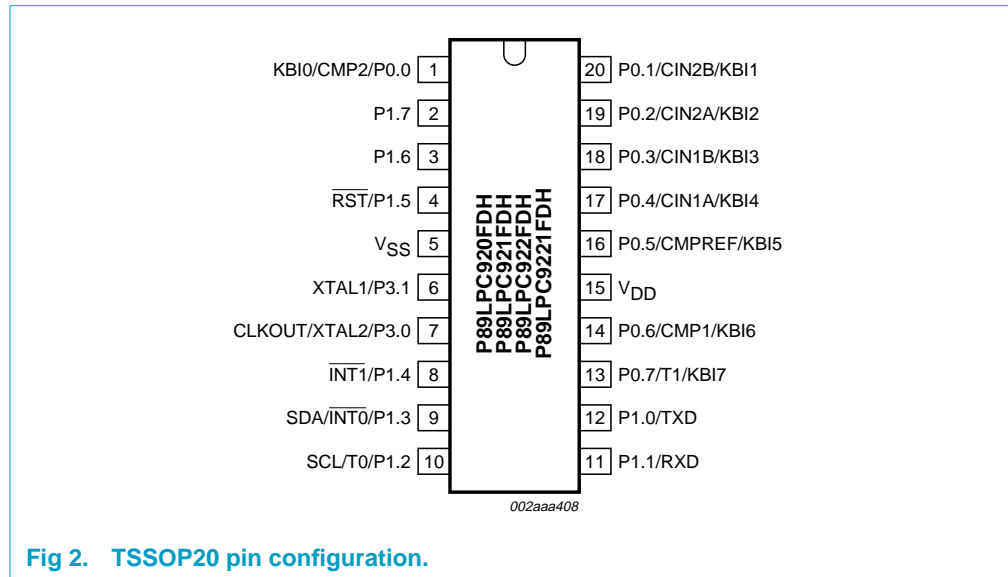

Fig 1. Block diagram.

5. Pinning information

5.1 Pinning



5.2 Pin description

Table 3: Pin description

Symbol	Pin	Type	Description
P0.0 to P0.7		I/O	<p>Port 0: Port 0 is an 8-bit I/O port with a user-configurable output type. During reset Port 0 latches are configured in the input only mode with the internal pull-up disabled. The operation of Port 0 pins as inputs and outputs depends upon the port configuration selected. Each port pin is configured independently. Refer to Section 8.12.1 “Port configurations” and Table 8 “DC electrical characteristics” for details.</p> <p>The Keypad Interrupt feature operates with Port 0 pins.</p> <p>All pins have Schmitt triggered inputs.</p> <p>Port 0 also provides various special functions as described below:</p>
	1	I/O	P0.0 — Port 0 bit 0.
		O	CMP2 — Comparator 2 output.
		I	KB10 — Keyboard input 0.
	20	I/O	P0.1 — Port 0 bit 1.
		I	CIN2B — Comparator 2 positive input B.
		I	KB11 — Keyboard input 1.
	19	I/O	P0.2 — Port 0 bit 2.
		I	CIN2A — Comparator 2 positive input A.
		I	KB12 — Keyboard input 2.
	18	I/O	P0.3 — Port 0 bit 3. High current source (P89LPC9221).
		I	CIN1B — Comparator 1 positive input B.
		I	KB13 — Keyboard input 3.
	17	I/O	P0.4 — Port 0 bit 4. High current source (P89LPC9221).
		I	CIN1A — Comparator 1 positive input A.
		I	KB14 — Keyboard input 4.
	16	I/O	P0.5 — Port 0 bit 5. High current source (P89LPC9221).
		I	CMPREF — Comparator reference (negative) input.
		I	KB15 — Keyboard input 5.
	14	I/O	P0.6 — Port 0 bit 6. High current source (P89LPC9221).
		O	CMP1 — Comparator 1 output.
		I	KB16 — Keyboard input 6.
	13	I/O	P0.7 — Port 0 bit 7. High current source (P89LPC9221).
		I/O	T1 — Timer/counter 1 external count input or overflow output.
		I	KB17 — Keyboard input 7.

Table 3: Pin description...continued

Symbol	Pin	Type	Description
P1.0 to P1.7		I/O, I ^[1]	<p>Port 1: Port 1 is an 8-bit I/O port with a user-configurable output type, except for three pins as noted below. During reset Port 1 latches are configured in the input only mode with the internal pull-up disabled. The operation of the configurable Port 1 pins as inputs and outputs depends upon the port configuration selected. Each of the configurable port pins are programmed independently. Refer to Section 8.12.1 "Port configurations" and Table 8 "DC electrical characteristics" for details. P1.2 - P1.3 are open drain when used as outputs. P1.5 is input only.</p> <p>All pins have Schmitt triggered inputs.</p> <p>Port 1 also provides various special functions as described below:</p>
	12	I/O	P1.0 — Port 1 bit 0.
		O	TXD — Transmitter output for the serial port.
	11	I/O	P1.1 — Port 1 bit 1.
		I	RXD — Receiver input for the serial port.
	10	I/O	P1.2 — Port 1 bit 2 (open-drain when used as output).
		I/O	T0 — Timer/counter 0 external count input or overflow output (open-drain when used as output).
		I/O	SCL — I ² C serial clock input/output.
	9	I/O	P1.3 — Port 1 bit 3 (open-drain when used as output).
		I	INT0 — External interrupt 0 input.
		I/O	SDA — I ² C serial data input/output.
	8	I/O	P1.4 — Port 1 bit 4. High current source (P89LPC9221).
		I	INT1 — External interrupt 1 input.
	4	I	P1.5 — Port 1 bit 5 (input only).
		I	RST — External Reset input (if selected via FLASH configuration). A LOW on this pin resets the microcontroller, causing I/O ports and peripherals to take on their default states, and the processor begins execution at address 0. When using an oscillator frequency above 12 MHz, the reset input function of P1.5 must be enabled. An external circuit is required to hold the device in reset at power-up until V_{DD} has reached its specified level. When system power is removed V_{DD} will fall below the minimum specified operating voltage. When using an oscillator frequency above 12 MHz, in some applications, an external brownout detect circuit may be required to hold the device in reset when V_{DD} falls below the minimum specified operating voltage.
	3	I/O	P1.6 — Port 1 bit 6. High current source (P89LPC9221).
	2	I/O	P1.7 — Port 1 bit 7. High current source (P89LPC9221).

Table 3: Pin description...continued

Symbol	Pin	Type	Description
P3.0 to P3.1		I/O	Port 3: Port 3 is an 2-bit I/O port with a user-configurable output type. During reset Port 3 latches are configured in the input only mode with the internal pull-up disabled. The operation of Port 3 pins as inputs and outputs depends upon the port configuration selected. Each port pin is configured independently. Refer to Section 8.12.1 "Port configurations" and Table 8 "DC electrical characteristics" for details. All pins have Schmitt triggered inputs. Port 3 also provides various special functions as described below:
	7	I/O	P3.0 — Port 3 bit 0.
		O	XTAL2 — Output from the oscillator amplifier (when a crystal oscillator option is selected via the FLASH configuration).
		O	CLKOUT — CPU clock divided by 2 when enabled via SFR bit (ENCLK - TRIM.6). It can be used if the CPU clock is the internal RC oscillator, watchdog oscillator or external clock input, except when XTAL1/XTAL2 are used to generate clock source for the real time clock/system timer.
	6	I/O	P3.1 — Port 3 bit 1.
		I	XTAL1 — Input to the oscillator circuit and internal clock generator circuits (when selected via the FLASH configuration). It can be a port pin if internal RC oscillator or watchdog oscillator is used as the CPU clock source, and if XTAL1/XTAL2 are not used to generate the clock for the real time clock/system timer.
V _{SS}	5	I	Ground: 0 V reference.
V _{DD}	15	I	Power Supply: This is the power supply voltage for normal operation as well as Idle and Power down modes.

[1] Input/Output for P1.0-P1.4, P1.6, P1.7. Input for P1.5.

6. Logic symbol

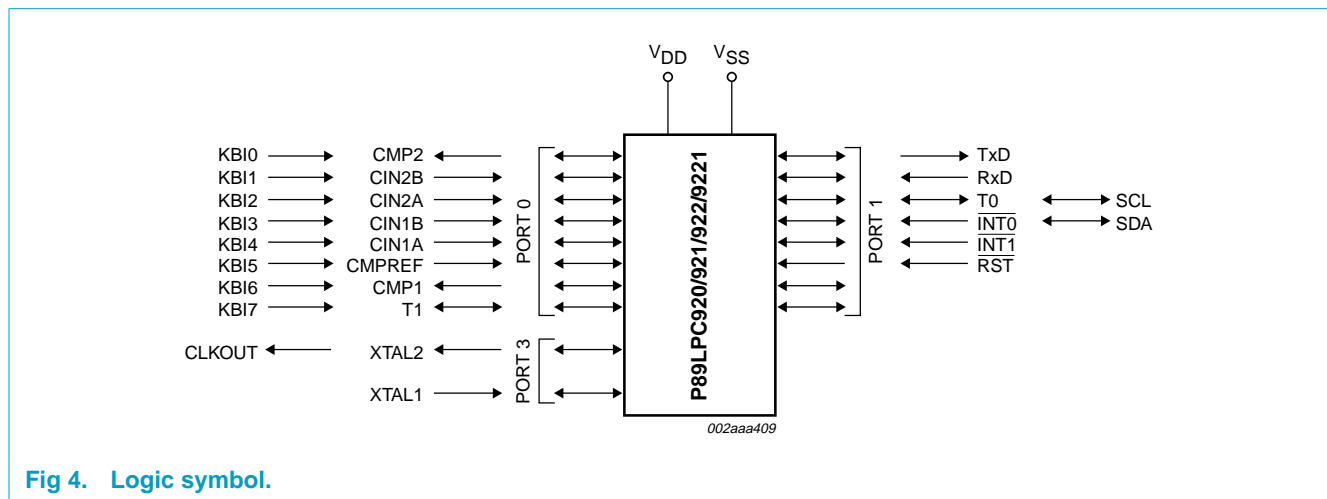

Fig 4. Logic symbol.

7. Special function registers

Remark: Special Function Registers (SFRs) accesses are restricted in the following ways:

- User must **not** attempt to access any SFR locations not defined.
- Accesses to any defined SFR locations must be strictly for the functions for the SFRs.
- SFR bits labeled '-', '0' or '1' can **only** be written and read as follows:
 - '-' Unless otherwise specified, **must** be written with '0', but can return any value when read (even if it was written with '0'). It is a reserved bit and may be used in future derivatives.
 - '0' **must** be written with '0', and will return a '0' when read.
 - '1' **must** be written with '1', and will return a '1' when read.

Table 4: Special function registers...continued
** indicates SFRs that are bit addressable.*

Name	Description	SFR addr.	Bit functions and addresses															
			MSB															
P1M2	Port 1 output mode 2	92H	(P1M2.7)	(P1M2.6)	-	(P1M2.4)	(P1M2.3)	(P1M2.2)	(P1M2.1)	(P1M2.0)							LSB	
P3M1	Port 3 output mode 1	B1H	-	-	-	-	-	-	(P3M1.1)	(P3M1.0)								
P3M2	Port 3 output mode 2	B2H	-	-	-	-	-	-	(P3M2.1)	(P3M2.0)								
PCON	Power control register	87H	SMOD1	SMOD0	BOPD	BOI	GF1	GF0	PMOD1	PMOD0								
PCONA	Power control register A	B5H	RTCPD	-	VCPD	-	I2PD	-	SPD	-								
			Bit address															
PSW*	Program status word	D0H	D7	D6	D5	D4	D3	D2	D1	D0								
PT0AD	Port 0 digital input disable	F6H	CY	AC	F0	RS1	RS0	OV	F1	P								
RSTSRC	Reset source register	DFH	-	-	BOF	POF	R_BK	R_WD	R_SF	R_EX								
RTCCON	Real-time clock control	D1H	RTCF	RTCS1	RTCS0	-	-	-	ERTC	RTCCN								
RTCH	Real-time clock register HIGH	D2H																
RTCL	Real-time clock register LOW	D3H																
SADDR	Serial port address register	A9H																
SADEN	Serial port address enable	B9H																
SBUF	Serial Port data buffer register	99H																
			Bit address															
SCON*	Serial port control	98H	9F	9E	9D	9C	9B	9A	99	98								
SSTAT	Serial port extended status register	BAH	SM0/FE	SM1	SM2	REN	TB8	RB8	TI	RI								
SP	Stack pointer	81H																
TAMOD	Timer 0 and 1 auxiliary mode	8FH	-	-	-	T1M2	-	-	-	T0M2								
			Bit address															
TCON*	Timer 0 and 1 control	88H	8F	8E	8D	8C	8B	8A	89	88								
TH0	Timer 0 HIGH	8CH	TF1	TR1	TF0	TR0	IE1	IT1	IE0	IT0								
TH1	Timer 1 HIGH	8DH																
TL0	Timer 0 LOW	8AH																
TL1	Timer 1 LOW	8BH																
TMOD	Timer 0 and 1 mode	89H	T1GATE	T1C/T	T1M1	T1M0	T0GATE	T0C/T	T0M1	T0M0								

Table 4: Special function registers...*continued*
** indicates SFRs that are bit addressable.*

Name	Description	SFR addr.	Bit functions and addresses									
			MSB									
TRIM	Internal oscillator trim register	96H	-	ENCLK	TRIM.5	TRIM.4	TRIM.3	TRIM.2	TRIM.1	TRIM.0		
WDCON	Watchdog control register	A7H	PRE2	PRE1	PRE0	-	-	WDRUN	WDTOF	WDCLK		
WDL	Watchdog load	C1H										
WFEED1	Watchdog feed 1	C2H										
WFEED2	Watchdog feed 2	C3H										

[1] All ports are in input only (high impedance) state after power-up.

[2] BRGR1 and BRGR0 must only be written if BRGEN in BRGCON SFR is '0'. If any are written while BRGEN = 1, the result is unpredictable.

[3] The RSTSRC register reflects the cause of the P89LPC920/921/922/9221 reset. Upon a power-up reset, all reset source flags are cleared except POF and reset value is xx110000.

[4] After reset, the value is 111001x1, i.e., PRE2-PRE0 are all '1', WDRUN = 1 and WDCLK = 1. WDTOF bit is '1' after watchdog reset and is '0' after power-on not affect WDTOF.

[5] On power-on reset, the TRIM SFR is initialized with a factory preprogrammed value. Other resets will not cause initialization of the TRIM register.

[6] The only reset source that affects these SFRs is power-on reset.

8. Functional description

Remark: Please refer to the *P89LPC920/921/922/9221 User's Manual* for a more detailed functional description.

8.1 Enhanced CPU

The P89LPC920/921/922/9221 uses an enhanced 80C51 CPU which runs at 6 times the speed of standard 80C51 devices. A machine cycle consists of two CPU clock cycles, and most instructions execute in one or two machine cycles.

8.2 Clocks

8.2.1 Clock definitions

The P89LPC920/921/922/9221 device has several internal clocks as defined below:

OSCCLK — Input to the DIVM clock divider. OSCCLK is selected from one of four clock sources (see [Figure 5](#)) and can also be optionally divided to a slower frequency (see [Section 8.7 “CPU Clock \(CCLK\) modification: DIVM register”](#)).

Note: f_{osc} is defined as the OSCCLK frequency.

CCLK — CPU clock; output of the clock divider. There are two CCLK cycles per machine cycle, and most instructions are executed in one to two machine cycles (two or four CCLK cycles).

RCCLK — The internal 7.373 MHz RC oscillator output.

PCLK — Clock for the various peripheral devices and is CCLK/2

8.2.2 CPU clock (OSCCLK)

The P89LPC920/921/922/9221 provides several user-selectable oscillator options in generating the CPU clock. This allows optimization for a range of needs from high precision to lowest possible cost. These options are configured when the FLASH is programmed and include an on-chip watchdog oscillator, an on-chip RC oscillator, an oscillator using an external crystal, or an external clock source. The crystal oscillator can be optimized for low, medium, or high frequency crystals covering a range from 20 kHz to 12 MHz.

8.2.3 Low speed oscillator option

This option supports an external crystal in the range of 20 kHz to 100 kHz. Ceramic resonators are also supported in this configuration.

8.2.4 Medium speed oscillator option

This option supports an external crystal in the range of 100 kHz to 4 MHz. Ceramic resonators are also supported in this configuration.

8.2.5 High speed oscillator option

This option supports an external crystal in the range of 4 MHz to 18 MHz. Ceramic resonators are also supported in this configuration. **When using an oscillator frequency above 12 MHz, the reset input function of P1.5 must be enabled. An external circuit is required to hold the device in reset at power-up until V_{DD} has reached its specified level. When system power is removed V_{DD} will fall below**

the minimum specified operating voltage. When using an oscillator frequency above 12 MHz, in some applications, an external brownout detect circuit may be required to hold the device in reset when V_{DD} falls below the minimum specified operating voltage.

8.2.6 Clock output

The P89LPC920/921/922/9221 supports a user-selectable clock output function on the XTAL2/CLKOUT pin when crystal oscillator is not being used. This condition occurs if another clock source has been selected (on-chip RC oscillator, watchdog oscillator, external clock input on X1) and if the Real-Time clock is not using the crystal oscillator as its clock source. This allows external devices to synchronize to the P89LPC920/921/922/9221. This output is enabled by the ENCLK bit in the TRIM register. The frequency of this clock output is $\frac{1}{2}$ that of the CCLK. If the clock output is not needed in Idle mode, it may be turned off prior to entering Idle, saving additional power.

8.3 On-chip RC oscillator option

The P89LPC920/921/922/9221 has a 6-bit TRIM register that can be used to tune the frequency of the RC oscillator. During reset, the TRIM value is initialized to a factory pre-programmed value to adjust the oscillator frequency to 7.373 MHz, $\pm 1\%$ at room temperature. End-user applications can write to the Trim register to adjust the on-chip RC oscillator to other frequencies.

8.4 Watchdog oscillator option

The watchdog has a separate oscillator which has a frequency of 400 kHz. This oscillator can be used to save power when a high clock frequency is not needed.

8.5 External clock input option

In this configuration, the processor clock is derived from an external source driving the XTAL1/P3.1 pin. The rate may be from 0 Hz up to 12 MHz. The XTAL2/P3.0 pin may be used as a standard port pin or a clock output. **When using an oscillator frequency above 12 MHz, the reset input function of P1.5 must be enabled. An external circuit is required to hold the device in reset at power-up until V_{DD} has reached its specified level. When system power is removed V_{DD} will fall below the minimum specified operating voltage. When using an oscillator frequency above 12 MHz, in some applications, an external brownout detect circuit may be required to hold the device in reset when V_{DD} falls below the minimum specified operating voltage.**

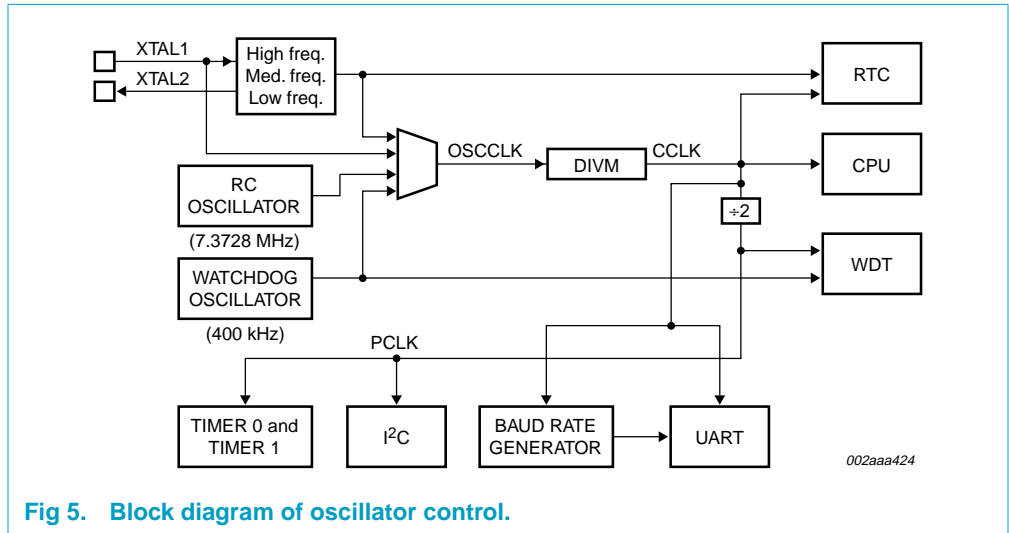

Fig 5. Block diagram of oscillator control.

8.6 CPU Clock (CCLK) wake-up delay

The P89LPC920/921/922/9221 has an internal wake-up timer that delays the clock until it stabilizes depending to the clock source used. If the clock source is any of the three crystal selections (low, medium and high frequencies) the delay is 992 OSCCLK cycles plus 60 to 100 μ s. If the clock source is either the internal RC oscillator, watchdog oscillator, or external clock, the delay is 224 OSCCLK cycles plus 60 to 100 μ s.

8.7 CPU Clock (CCLK) modification: DIVM register

The OSCCLK frequency can be divided down up to 510 times by configuring a dividing register, DIVM, to generate CCLK. This feature makes it possible to temporarily run the CPU at a lower rate, reducing power consumption. By dividing the clock, the CPU can retain the ability to respond to events that would not exit Idle mode by executing its normal program at a lower rate. This can also allow bypassing the oscillator start-up time in cases where Power-down mode would otherwise be used. The value of DIVM may be changed by the program at any time without interrupting code execution.

8.8 Low power select

The P89LPC920/921/922/9221 is designed to run at 18 MHz (CCLK) maximum. However, if CCLK is 8 MHz or slower, the CLKLP SFR bit (AUXR1.7) can be set to '1' to lower the power consumption further. On any reset, CLKLP is '0' allowing highest performance access. This bit can then be set in software if CCLK is running at 8 MHz or slower.

8.9 Memory organization

The various P89LPC920/921/922/9221 memory spaces are as follows:

- DATA
128 bytes of internal data memory space (00h:7Fh) accessed via direct or indirect addressing, using instruction other than MOVX and MOVC. All or part of the Stack may be in this area.
- IDATA
Indirect Data. 256 bytes of internal data memory space (00h:FFh) accessed via indirect addressing using instructions other than MOVX and MOVC. All or part of the Stack may be in this area. This area includes the DATA area and the 128 bytes immediately above it.
- SFR
Special Function Registers. Selected CPU registers and peripheral control and status registers, accessible only via direct addressing.
- CODE
64 kB of Code memory space, accessed as part of program execution and via the MOVC instruction. The P89LPC920/921/922/9221 has 2 kB/4 kB/8 kB of on-chip Code memory.

8.10 Data RAM arrangement

The 256 bytes of on-chip RAM are organized as shown in [Table 5](#).

Table 5: On-chip data memory usages

Type	Data RAM	Size (bytes)
DATA	Memory that can be addressed directly and indirectly	128
IDATA	Memory that can be addressed indirectly	256

8.11 Interrupts

The P89LPC920/921/922/9221 uses a four priority level interrupt structure. This allows great flexibility in controlling the handling of the many interrupt sources. The P89LPC920/921/922/9221 supports 12 interrupt sources: external interrupts 0 and 1, timers 0 and 1, serial port Tx, serial port Rx, combined serial port Rx/Tx, brownout detect, watchdog/real-time clock, I²C, keyboard, and comparators 1 and 2.

Each interrupt source can be individually enabled or disabled by setting or clearing a bit in the interrupt enable registers IEN0 or IEN1. The IEN0 register also contains a global disable bit, EA, which disables all interrupts.

Each interrupt source can be individually programmed to one of four priority levels by setting or clearing bits in the interrupt priority registers IP0, IP0H, IP1, and IP1H. An interrupt service routine in progress can be interrupted by a higher priority interrupt, but not by another interrupt of the same or lower priority. The highest priority interrupt service cannot be interrupted by any other interrupt source. If two requests of different priority levels are pending at the start of an instruction, the request of higher priority level is serviced.

If requests of the same priority level are pending at the start of an instruction, an internal polling sequence determines which request is serviced. This is called the arbitration ranking. Note that the arbitration ranking is only used to resolve pending requests of the same priority level.

8.11.1 External interrupt inputs

The P89LPC920/921/922/9221 has two external interrupt inputs as well as the Keypad Interrupt function. The two interrupt inputs are identical to those present on the standard 80C51 microcontrollers.

These external interrupts can be programmed to be level-triggered or edge-triggered by setting or clearing bit IT1 or IT0 in Register TCON.

In edge-triggered mode if successive samples of the $\overline{\text{INTn}}$ pin show a HIGH in one cycle and a LOW in the next cycle, the interrupt request flag IEN in TCON is set, causing an interrupt request.

If an external interrupt is enabled when the P89LPC920/921/922/9221 is put into Power-down or Idle mode, the interrupt will cause the processor to wake-up and resume operation. Refer to [Section 8.14 "Power reduction modes"](#) for details.

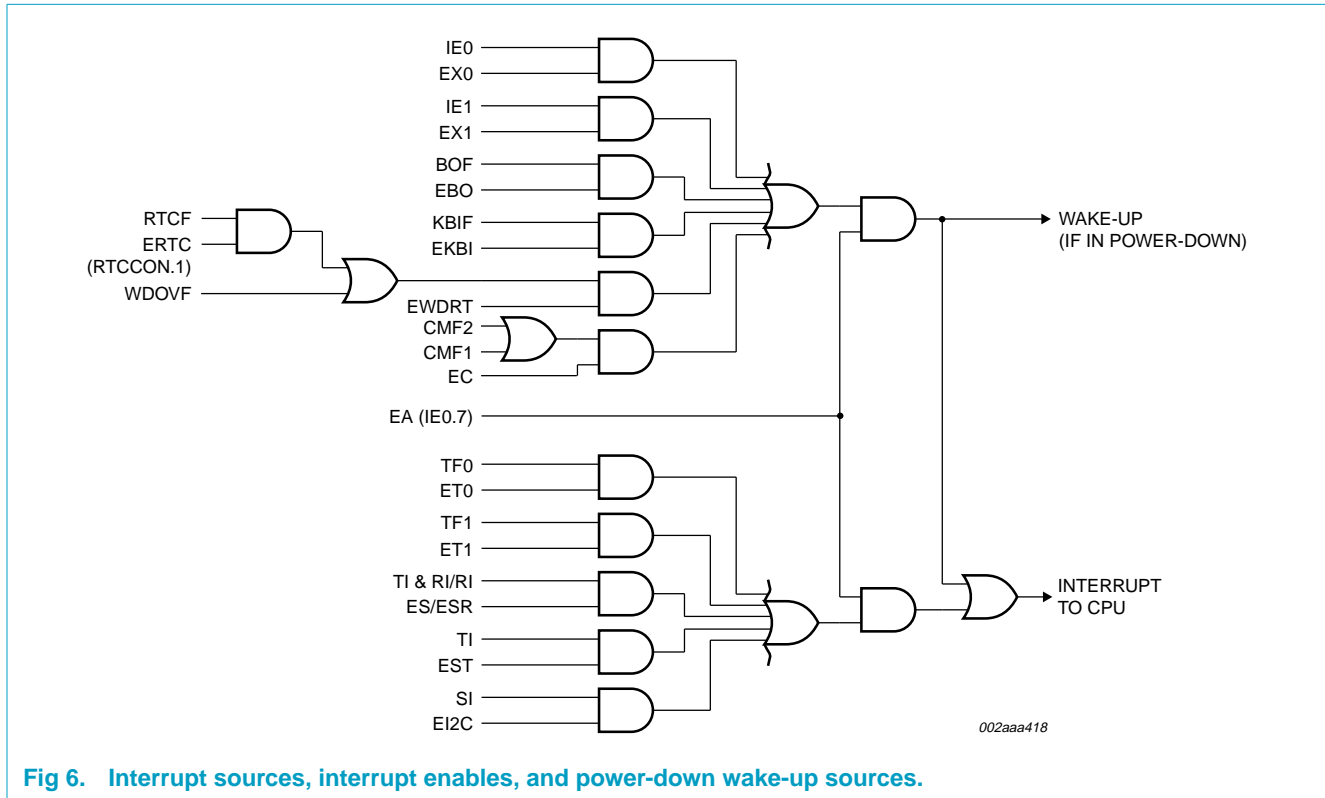

Fig 6. Interrupt sources, interrupt enables, and power-down wake-up sources.

8.12 I/O ports

The P89LPC920/921/922/9221 has three I/O ports: Port 0, Port 1, and Port 3. Ports 0 and 1 are 8-bit ports, and Port 3 is a 2-bit port. The exact number of I/O pins available depend upon the clock and reset options chosen, as shown in Table 6.

Table 6: Number of I/O pins available

Clock source	Reset option	Number of I/O pins (20-pin package)
On-chip oscillator or watchdog oscillator	No external reset (except during power-up)	18
	External $\overline{\text{RST}}$ pin supported ^[1]	17
External clock input	No external reset (except during power-up)	17
	External $\overline{\text{RST}}$ pin supported ^[1]	16
Low/medium/high speed oscillator (external crystal or resonator)	No external reset (except during power-up)	16
	External $\overline{\text{RST}}$ pin supported ^[1]	15

[1] Required for operation above 12 MHz.

8.12.1 Port configurations

All but three I/O port pins on the P89LPC920/921/922/9221 may be configured by software to one of four types on a bit-by-bit basis. These are: quasi-bidirectional (standard 80C51 port outputs), push-pull, open drain, and input-only. Two configuration registers for each port select the output type for each port pin.

P1.5 ($\overline{\text{RST}}$) can only be an input and cannot be configured.

P1.2 (SCL/T0) and P1.3 (SDA/ $\overline{\text{INT0}}$) may only be configured to be either input-only or open-drain.

8.12.2 Quasi-bidirectional output configuration

Quasi-bidirectional output type can be used as both an input and output without the need to reconfigure the port. This is possible because when the port outputs a logic HIGH, it is weakly driven, allowing an external device to pull the pin LOW. When the pin is driven LOW, it is driven strongly and able to sink a fairly large current. These features are somewhat similar to an open-drain output except that there are three pull-up transistors in the quasi-bidirectional output that serve different purposes.

The P89LPC920/921/922/9221 is a 3 V device, but the pins are 5 V-tolerant. In quasi-bidirectional mode, if a user applies 5 V on the pin, there will be a current flowing from the pin to V_{DD} , causing extra power consumption. Therefore, applying 5 V in quasi-bidirectional mode is discouraged.

A quasi-bidirectional port pin has a Schmitt-triggered input that also has a glitch suppression circuit.

8.12.3 Open-drain output configuration

The open-drain output configuration turns off all pull-ups and only drives the pull-down transistor of the port driver when the port latch contains a logic '0'. To be used as a logic output, a port configured in this manner must have an external pull-up, typically a resistor tied to V_{DD} .

An open-drain port pin has a Schmitt-triggered input that also has a glitch suppression circuit.

8.12.4 Input-only configuration

The input-only port configuration has no output drivers. It is a Schmitt-triggered input that also has a glitch suppression circuit.

8.12.5 Push-pull output configuration

The push-pull output configuration has the same pull-down structure as both the open-drain and the quasi-bidirectional output modes, but provides a continuous strong pull-up when the port latch contains a logic '1'. The push-pull mode may be used when more source current is needed from a port output. A push-pull port pin has a Schmitt-triggered input that also has a glitch suppression circuit. The P89LPC9221 device has high source current on eight pins in push-pull mode. See [Table 8 "DC electrical characteristics"](#).

8.12.6 Port 0 analog functions

The P89LPC920/921/922/9221 incorporates two Analog Comparators. In order to give the best analog function performance and to minimize power consumption, pins that are being used for analog functions must have the digital outputs and digital inputs disabled.

Digital outputs are disabled by putting the port output into the Input-Only (high impedance) mode as described in [Section 8.12.4](#).

Digital inputs on Port 0 may be disabled through the use of the PT0AD register, bits 1:5. On any reset, PT0AD1:5 defaults to '0's to enable digital functions.

8.12.7 Additional port features

After power-up, all pins are in Input-Only mode. **Please note that this is different from the LPC76x series of devices.**

- After power-up, all I/O pins except P1.5, may be configured by software.
- Pin P1.5 is input only. Pins P1.2 and P1.3 and are configurable for either input-only or open-drain.

Every output on the P89LPC920/921/922/9221 has been designed to sink typical LED drive current. However, there is a maximum total output current for all ports which must not be exceeded. Please refer to [Table 8 “DC electrical characteristics”](#) for detailed specifications.

All ports pins that can function as an output have slew rate controlled outputs to limit noise generated by quickly switching output signals. The slew rate is factory-set to approximately 10 ns rise and fall times.

8.13 Power monitoring functions

The P89LPC920/921/922/9221 incorporates power monitoring functions designed to prevent incorrect operation during initial power-up and power loss or reduction during operation. This is accomplished with two hardware functions: Power-on Detect and Brownout detect.

8.13.1 Brownout detection

The Brownout detect function determines if the power supply voltage drops below a certain level. The default operation is for a Brownout detection to cause a processor reset, however it may alternatively be configured to generate an interrupt.

Brownout detection may be enabled or disabled in software.

If Brownout detection is enabled, the brownout condition occurs when V_{DD} falls below the brownout trip voltage, V_{BO} (see [Table 8 “DC electrical characteristics”](#)), and is negated when V_{DD} rises above V_{BO} . If the P89LPC920/921/922/9221 device is to operate with a power supply that can be below 2.7 V, BOE should be left in the unprogrammed state so that the device can operate at 2.4 V, otherwise continuous brownout reset may prevent the device from operating.

For correct activation of Brownout detect, the V_{DD} rise and fall times must be observed. Please see [Table 8 “DC electrical characteristics”](#) for specifications.

8.13.2 Power-on detection

The Power-on Detect has a function similar to the Brownout detect, but is designed to work as power comes up initially, before the power supply voltage reaches a level where Brownout detect can work. The POF flag in the RSTSRC register is set to indicate an initial power-up condition. The POF flag will remain set until cleared by software.

8.14 Power reduction modes

The P89LPC920/921/922/9221 supports three different power reduction modes. These modes are Idle mode, Power-down mode, and total Power-down mode.

8.14.1 Idle mode

Idle mode leaves peripherals running in order to allow them to activate the processor when an interrupt is generated. Any enabled interrupt source or reset may terminate Idle mode.

8.14.2 Power-down mode

The Power-down mode stops the oscillator in order to minimize power consumption. The P89LPC920/921/922/9221 exits Power-down mode via any reset, or certain interrupts. In Power-down mode, the power supply voltage may be reduced to the RAM keep-alive voltage V_{RAM} . This retains the RAM contents at the point where Power-down mode was entered. SFR contents are not guaranteed after V_{DD} has been lowered to V_{RAM} , therefore it is highly recommended to wake up the processor via reset in this case. V_{DD} must be raised to within the operating range before the Power-down mode is exited.

Some chip functions continue to operate and draw power during Power-down mode, increasing the total power used during Power-down. These include: Brownout detect, Watchdog Timer, Comparators (note that Comparators can be powered-down separately), and Real-Time Clock (RTC)/System Timer. The internal RC oscillator is disabled unless both the RC oscillator has been selected as the system clock AND the RTC is enabled.

8.14.3 Total Power-down mode

This is the same as Power-down mode except that the brownout detection circuitry and the voltage comparators are also disabled to conserve additional power. The internal RC oscillator is disabled unless both the RC oscillator has been selected as the system clock **and** the RTC is enabled. If the internal RC oscillator is used to clock the RTC during Power-down, there will be high power consumption. Please use an external low frequency clock to achieve low power with the Real-Time Clock running during Power-down.

8.15 Reset

The P1.5/ \overline{RST} pin can function as either an active-LOW reset input or as a digital input, P1.5. The RPE (Reset Pin Enable) bit in UCFG1, when set to '1', enables the external reset input function on P1.5. When cleared, P1.5 may be used as an input pin.

Remark: During a power-up sequence, the RPE selection is overridden and this pin will always function as a reset input. **An external circuit connected to this pin should not hold this pin LOW during a power-on sequence as this will keep the device in reset.** After power-up this input will function either as an external reset input or as a digital input as defined by the RPE bit. Only a power-up reset will temporarily override the selection defined by RPE bit. Other sources of reset will not override the RPE bit.

Remark: During a power cycle, V_{DD} must fall below V_{POR} (see [Table 8 "DC electrical characteristics" on page 36](#)) before power is reapplied, in order to ensure a power-on reset.

Reset can be triggered from the following sources:

- External reset pin (during power-up or if user configured via UCFG1). This option must be used for an oscillator frequency above 12 MHz);
- Power-on detect;
- Brownout detect;
- Watchdog Timer;
- Software reset;
- UART break character detect reset.

For every reset source, there is a flag in the Reset Register, RSTSRC. The user can read this register to determine the most recent reset source. These flag bits can be cleared in software by writing a '0' to the corresponding bit. More than one flag bit may be set:

- During a power-on reset, both POF and BOF are set but the other flag bits are cleared.
- For any other reset, previously set flag bits that have not been cleared will remain set.

8.15.1 Reset vector

Following reset, the P89LPC920/921/922/9221 will fetch instructions from either address 0000h or the Boot address. The Boot address is formed by using the Boot Vector as the high byte of the address and the low byte of the address = 00h.

The Boot address will be used if a UART break reset occurs, or the non-volatile Boot Status bit (BOOTSTAT.0) = 1, or the device is forced into ISP mode during power-on (see *P89LPC920/921/922/9221 User's Manual*). Otherwise, instructions will be fetched from address 0000H.

8.16 Timers/counters 0 and 1

The P89LPC920/921/922/9221 has two general purpose counter/timers which are upward compatible with the standard 80C51 Timer 0 and Timer 1. Both can be configured to operate either as timers or event counter. An option to automatically toggle the T0 and/or T1 pins upon timer overflow has been added.

In the 'Timer' function, the register is incremented every machine cycle.

In the 'Counter' function, the register is incremented in response to a 1-to-0 transition at its corresponding external input pin, T0 or T1. In this function, the external input is sampled once during every machine cycle.

Timer 0 and Timer 1 have five operating modes (modes 0, 1, 2, 3 and 6). Modes 0, 1, 2 and 6 are the same for both Timers/Counters. Mode 3 is different.

8.16.1 Mode 0

Putting either Timer into Mode 0 makes it look like an 8048 Timer, which is an 8-bit Counter with a divide-by-32 prescaler. In this mode, the Timer register is configured as a 13-bit register. Mode 0 operation is the same for Timer 0 and Timer 1.

8.16.2 Mode 1

Mode 1 is the same as Mode 0, except that all 16 bits of the timer register are used.

8.16.3 Mode 2

Mode 2 configures the Timer register as an 8-bit Counter with automatic reload. Mode 2 operation is the same for Timer 0 and Timer 1.

8.16.4 Mode 3

When Timer 1 is in Mode 3 it is stopped. Timer 0 in Mode 3 forms two separate 8-bit counters and is provided for applications that require an extra 8-bit timer. When Timer 1 is in Mode 3 it can still be used by the serial port as a baud rate generator.

8.16.5 Mode 6

In this mode, the corresponding timer can be changed to a PWM with a full period of 256 timer clocks.

8.16.6 Timer overflow toggle output

Timers 0 and 1 can be configured to automatically toggle a port output whenever a timer overflow occurs. The same device pins that are used for the T0 and T1 count inputs are also used for the timer toggle outputs. The port outputs will be a logic 1 prior to the first timer overflow when this mode is turned on.

8.17 Real-Time clock/system timer

The P89LPC920/921/922/9221 has a simple Real-Time clock that allows a user to continue running an accurate timer while the rest of the device is powered-down. The Real-Time clock can be a wake-up or an interrupt source. The Real-Time clock is a 23-bit down counter comprised of a 7-bit prescaler and a 16-bit loadable down counter. When it reaches all '0's, the counter will be reloaded again and the RTCF flag will be set. The clock source for this counter can be either the CPU clock (CCLK) or the XTAL oscillator, provided that the XTAL oscillator is not being used as the CPU clock. If the XTAL oscillator is used as the CPU clock, then the RTC will use CCLK as its clock source. Only power-on reset will reset the Real-Time clock and its associated SFRs to the default state.

8.18 UART

The P89LPC920/921/922/9221 has an enhanced UART that is compatible with the conventional 80C51 UART except that Timer 2 overflow cannot be used as a baud rate source. The P89LPC920/921/922/9221 does include an independent Baud Rate Generator. The baud rate can be selected from the oscillator (divided by a constant), Timer 1 overflow, or the independent Baud Rate Generator. In addition to the baud rate generation, enhancements over the standard 80C51 UART include Framing Error detection, automatic address recognition, selectable double buffering and several interrupt options. The UART can be operated in 4 modes: shift register, 8-bit UART, 9-bit UART, and CPU clock/32 or CPU clock/16.

8.18.1 Mode 0

Serial data enters and exits through RxD. TxD outputs the shift clock. 8 bits are transmitted or received, LSB first. The baud rate is fixed at $\frac{1}{16}$ of the CPU clock frequency.

8.18.2 Mode 1

10 bits are transmitted (through TxD) or received (through RxD): a start bit (logical '0'), 8 data bits (LSB first), and a stop bit (logical '1'). When data is received, the stop bit is stored in RB8 in Special Function Register SCON. The baud rate is variable and is determined by the Timer 1 overflow rate or the Baud Rate Generator (described in [Section 8.18.5 "Baud rate generator and selection"](#)).

8.18.3 Mode 2

11 bits are transmitted (through TxD) or received (through RxD): start bit (logical '0'), 8 data bits (LSB first), a programmable 9th data bit, and a stop bit (logical '1'). When data is transmitted, the 9th data bit (TB8 in SCON) can be assigned the value of '0' or '1'. Or, for example, the parity bit (P, in the PSW) could be moved into TB8. When data is received, the 9th data bit goes into RB8 in Special Function Register SCON, while the stop bit is not saved. The baud rate is programmable to either $\frac{1}{16}$ or $\frac{1}{32}$ of the CPU clock frequency, as determined by the SMOD1 bit in PCON.

8.18.4 Mode 3

11 bits are transmitted (through TxD) or received (through RxD): a start bit (logical '0'), 8 data bits (LSB first), a programmable 9th data bit, and a stop bit (logical '1'). In fact, Mode 3 is the same as Mode 2 in all respects except baud rate. The baud rate in Mode 3 is variable and is determined by the Timer 1 overflow rate or the Baud Rate Generator (described in [Section 8.18.5 "Baud rate generator and selection"](#)).

8.18.5 Baud rate generator and selection

The P89LPC920/921/922/9221 enhanced UART has an independent Baud Rate Generator. The baud rate is determined by a baud-rate preprogrammed into the BRGR1 and BRGR0 SFRs which together form a 16-bit baud rate divisor value that works in a similar manner as Timer 1 but is much more accurate. If the baud rate generator is used, Timer 1 can be used for other timing functions.

The UART can use either Timer 1 or the baud rate generator output (see [Figure 7](#)). Note that Timer T1 is further divided by 2 if the SMOD1 bit (PCON.7) is set. The independent Baud Rate Generator uses OSCCLK.

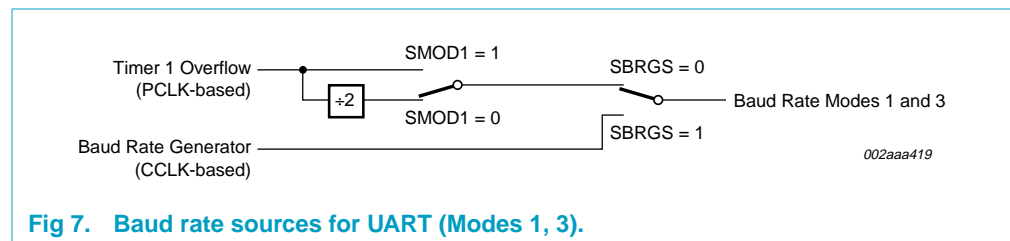

Fig 7. Baud rate sources for UART (Modes 1, 3).

8.18.6 Framing error

Framing error is reported in the status register (SSTAT). In addition, if SMOD0 (PCON.6) is '1', framing errors can be made available in SCON.7 respectively. If SMOD0 is '0', SCON.7 is SM0. It is recommended that SM0 and SM1 (SCON.7:6) are set up when SMOD0 is '0'.

8.18.7 Break detect

Break detect is reported in the status register (SSTAT). A break is detected when 11 consecutive bits are sensed LOW. The break detect can be used to reset the device and force the device into ISP mode.

8.18.8 Double buffering

The UART has a transmit double buffer that allows buffering of the next character to be written to SBUF while the first character is being transmitted. Double buffering allows transmission of a string of characters with only one stop bit between any two characters, as long as the next character is written between the start bit and the stop bit of the previous character.

Double buffering can be disabled. If disabled (DBMOD, i.e., SSTAT.7 = '0'), the UART is compatible with the conventional 80C51 UART. If enabled, the UART allows writing to SnBUF while the previous data is being shifted out. Double buffering is only allowed in Modes 1, 2 and 3. When operated in Mode 0, double buffering must be disabled (DBMOD = '0').

8.18.9 Transmit interrupts with double buffering enabled (Modes 1, 2 and 3)

Unlike the conventional UART, in double buffering mode, the Tx interrupt is generated when the double buffer is ready to receive new data.

8.18.10 The 9th bit (bit 8) in double buffering (Modes 1, 2 and 3)

If double buffering is disabled TB8 can be written before or after SBUF is written, as long as TB8 is updated some time before that bit is shifted out. TB8 must not be changed until the bit is shifted out, as indicated by the Tx interrupt.

If double buffering is enabled, TB8 **must** be updated before SBUF is written, as TB8 will be double-buffered together with SBUF data.

8.19 I²C-bus serial interface

I²C-bus uses two wires (SDA and SCL) to transfer information between devices connected to the bus, and it has the following features:

- Bidirectional data transfer between masters and slaves
- Multimaster bus (no central master)
- Arbitration between simultaneously transmitting masters without corruption of serial data on the bus
- Serial clock synchronization allows devices with different bit rates to communicate via one serial bus
- Serial clock synchronization can be used as a handshake mechanism to suspend and resume serial transfer
- The I²C-bus may be used for test and diagnostic purposes.

A typical I²C-bus configuration is shown in Figure 8. The P89LPC920/921/922/9221 device provides a byte-oriented I²C-bus interface that supports data transfers up to 400 kHz.

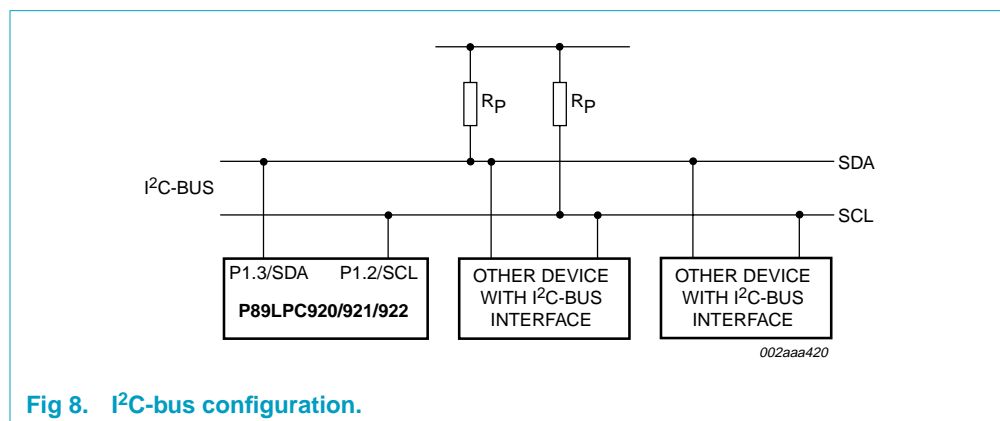

Fig 8. I²C-bus configuration.

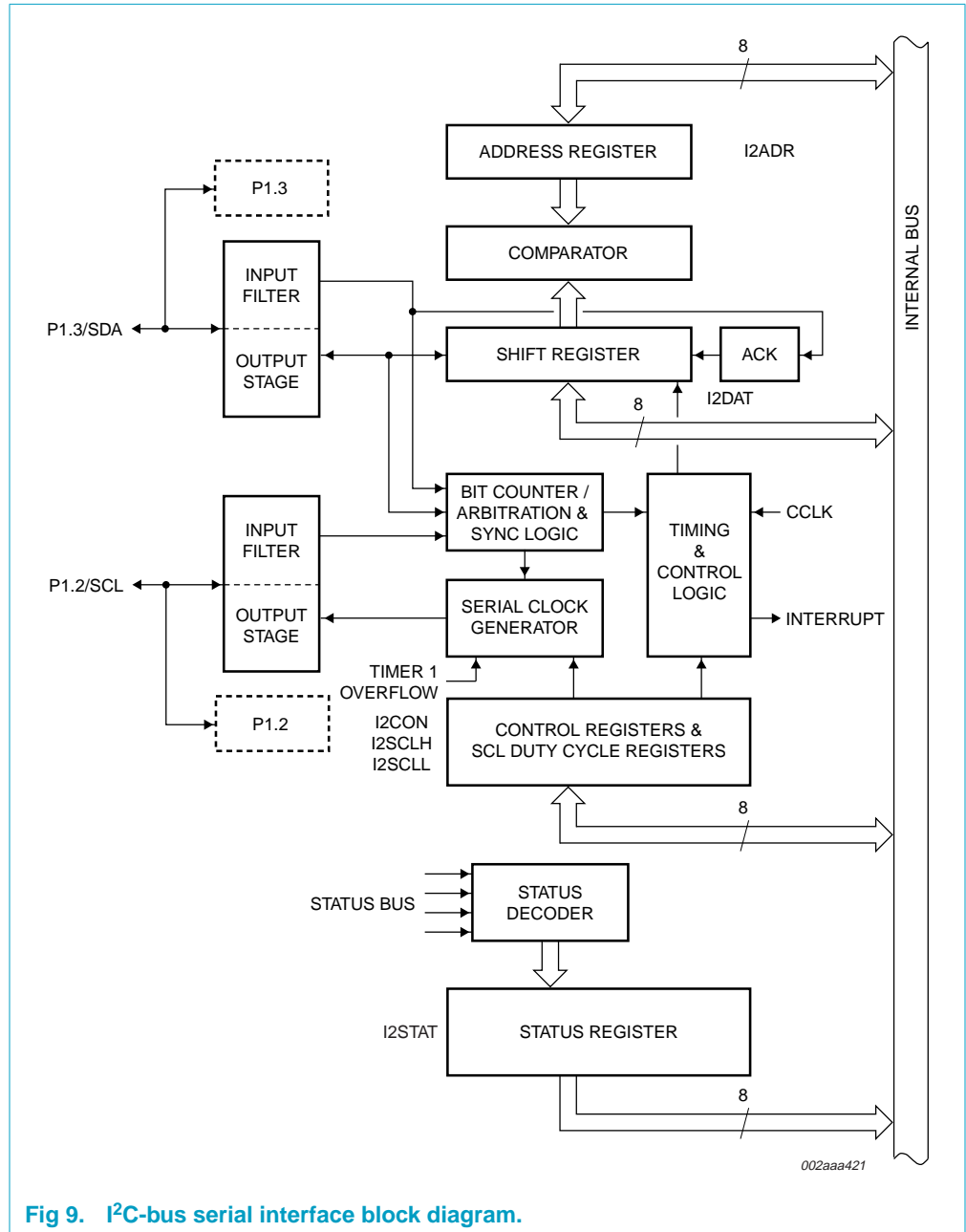

Fig 9. I²C-bus serial interface block diagram.

8.20 Analog comparators

Two analog comparators are provided on the P89LPC920/921/922/9221. Input and output options allow use of the comparators in a number of different configurations. Comparator operation is such that the output is a logical one (which may be read in a register and/or routed to a pin) when the positive input (one of two selectable pins) is greater than the negative input (selectable from a pin or an internal reference voltage). Otherwise the output is a zero. Each comparator may be configured to cause an interrupt when the output value changes.

The overall connections to both comparators are shown in Figure 10. The comparators function to $V_{DD} = 2.4$ V.

When each comparator is first enabled, the comparator output and interrupt flag are not guaranteed to be stable for 10 microseconds. The corresponding comparator interrupt should not be enabled during that time, and the comparator interrupt flag must be cleared before the interrupt is enabled in order to prevent an immediate interrupt service.

When a comparator is disabled the comparator's output, CO_x , goes HIGH. If the comparator output was LOW and then is disabled, the resulting transition of the comparator output from a LOW to HIGH state will set the comparator flag, CMF_x . This will cause an interrupt if the comparator interrupt is enabled. The user should therefore disable the comparator interrupt prior to disabling the comparator. Additionally, the user should clear the comparator flag, CMF_x , after disabling the comparator.

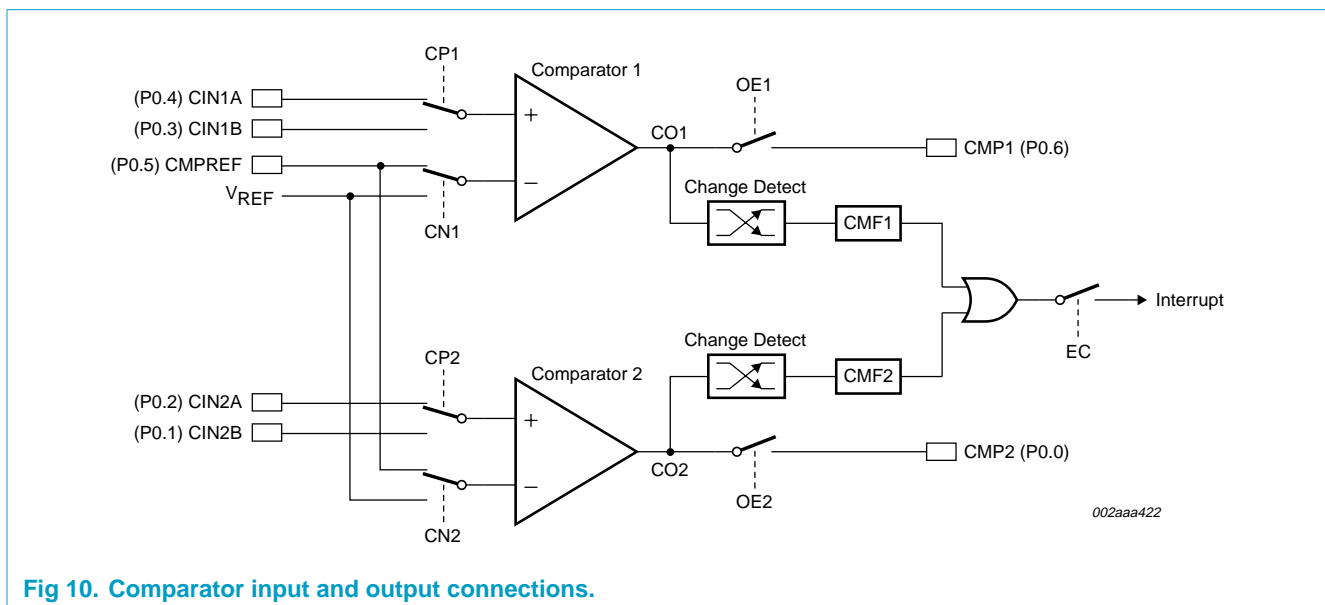

Fig 10. Comparator input and output connections.

8.20.1 Internal reference voltage

An internal reference voltage generator may supply a default reference when a single comparator input pin is used. The value of the internal reference voltage, referred to as V_{REF} , is 1.23 V $\pm 10\%$.

8.20.2 Comparator interrupt

Each comparator has an interrupt flag contained in its configuration register. This flag is set whenever the comparator output changes state. The flag may be polled by software or may be used to generate an interrupt. The two comparators use one common interrupt vector. If both comparators enable interrupts, after entering the interrupt service routine, the user needs to read the flags to determine which comparator caused the interrupt.

8.20.3 Comparators and power reduction modes

Either or both comparators may remain enabled when Power-down or Idle mode is activated, but both comparators are disabled automatically in Total Power-down mode. If a comparator interrupt is enabled (except in Total Power-down mode), a change of the comparator output state will generate an interrupt and wake up the processor. If the comparator output to a pin is enabled, the pin should be configured in the push-pull mode in order to obtain fast switching times while in Power-down mode. The reason is that with the oscillator stopped, the temporary strong pull-up that normally occurs during switching on a quasi-bidirectional port pin does not take place.

Comparators consume power in Power-down and Idle modes, as well as in the normal operating mode. This fact should be taken into account when system power consumption is an issue. To minimize power consumption, the user can disable the comparators via PCONA.5, or put the device in Total Power-down mode.

8.21 Keypad interrupt (KBI)

The Keypad Interrupt function is intended primarily to allow a single interrupt to be generated when Port 0 is equal to or not equal to a certain pattern. This function can be used for bus address recognition or keypad recognition. The user can configure the port via SFRs for different tasks.

The Keypad Interrupt Mask Register (KBMASK) is used to define which input pins connected to Port 0 can trigger the interrupt. The Keypad Pattern Register (KBPATN) is used to define a pattern that is compared to the value of Port 0. The Keypad Interrupt Flag (KBIF) in the Keypad Interrupt Control Register (KBCON) is set when the condition is matched while the Keypad Interrupt function is active. An interrupt will be generated if enabled. The PATN_SEL bit in the Keypad Interrupt Control Register (KBCON) is used to define equal or not-equal for the comparison.

In order to use the Keypad Interrupt as an original KBI function like in 87LPC76x series, the user needs to set KBPATN = 0FFH and PATN_SEL = 1 (not equal), then any key connected to Port 0 which is enabled by the KBMASK register will cause the hardware to set KBIF and generate an interrupt if it has been enabled. The interrupt may be used to wake up the CPU from Idle or Power-down modes. This feature is particularly useful in handheld, battery-powered systems that need to carefully manage power consumption yet also need to be convenient to use.

In order to set the flag and cause an interrupt, the pattern on Port 0 must be held longer than 6 CCLKs.

8.22 Watchdog timer

The Watchdog timer causes a system reset when it underflows as a result of a failure to feed the timer prior to the timer reaching its terminal count. It consists of a programmable 12-bit prescaler, and an 8-bit down counter. The down counter is decremented by a tap taken from the prescaler. The clock source for the prescaler is either the PCLK or the nominal 400 kHz Watchdog oscillator. The Watchdog timer can only be reset by a power-on reset. When the watchdog feature is disabled, it can be used as an interval timer and may generate an interrupt. Figure 11 shows the Watchdog timer in watchdog mode. Feeding the watchdog requires a two-byte sequence. If PCLK is selected as the watchdog clock and the CPU is powered-down, the watchdog is disabled. The Watchdog timer has a time-out period that ranges from a few μs to a few seconds. Please refer to the *P89LPC920/921/922/9221* User's Manual for more details.

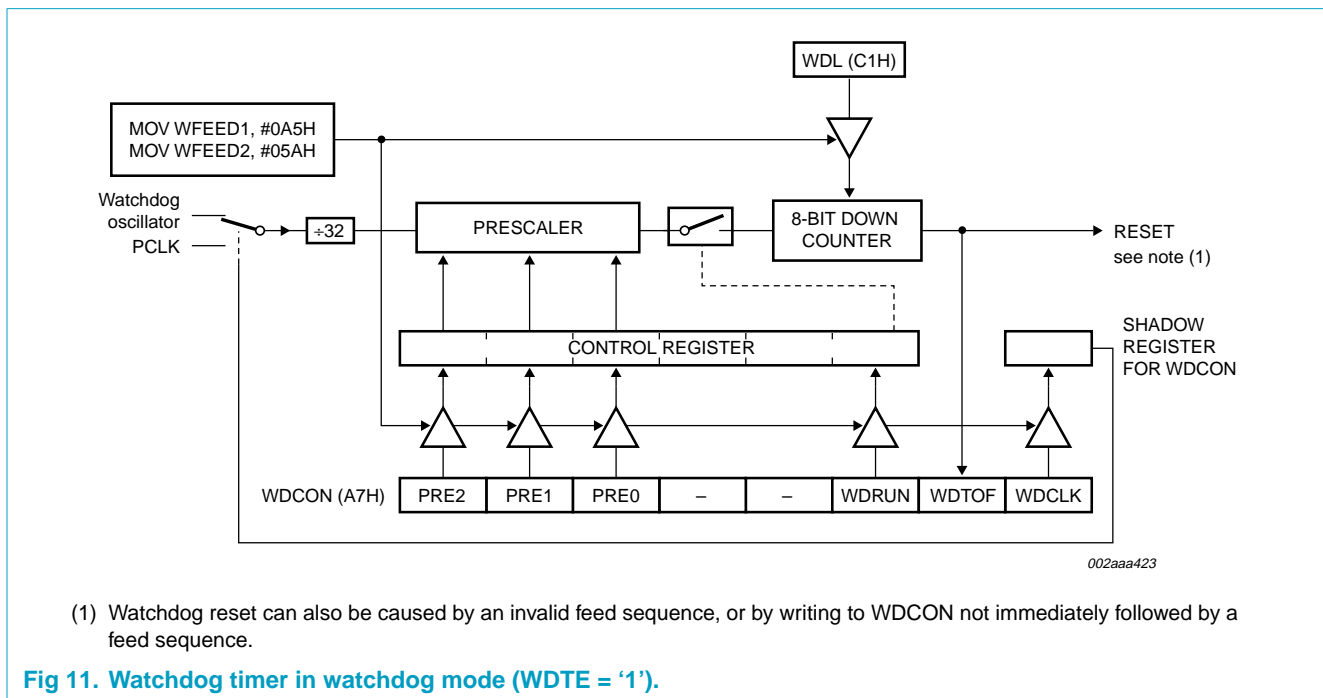

8.23 Additional features

8.23.1 Software reset

The SRST bit in AUXR1 gives software the opportunity to reset the processor completely, as if an external reset or watchdog reset had occurred. Care should be taken when writing to AUXR1 to avoid accidental software resets.

8.23.2 Dual data pointers

The dual Data Pointers (DPTR) provides two different Data Pointers to specify the address used with certain instructions. The DPS bit in the AUXR1 register selects one of the two Data Pointers. Bit 2 of AUXR1 is permanently wired as a logic '0' so that the DPS bit may be toggled (thereby switching Data Pointers) simply by incrementing the AUXR1 register, without the possibility of inadvertently altering other bits in the register.

8.24 Flash program memory

8.24.1 General description

The P89LPC920/921/922/9221 Flash memory provides in-circuit electrical erasure and programming. The Flash can be read, erased, or written as bytes. The Sector and Page Erase functions can erase any Flash sector (1 kB) or page (64 bytes). The Chip Erase operation will erase the entire program memory. In-System Programming and standard parallel programming are both available. On-chip erase and write timing generation contribute to a user-friendly programming interface. The P89LPC920/921/922/9221 Flash reliably stores memory contents even after 10,000 erase and program cycles. The cell is designed to optimize the erase and programming mechanisms. The P89LPC920/921/922/9221 uses V_{DD} as the supply voltage to perform the Program/Erase algorithms.

8.24.2 Features

- Parallel programming with industry-standard commercial programmers.
- In-Circuit serial Programming (ICP) with industry-standard commercial programmers.
- IAP-Lite allows individual and multiple bytes of code memory to be used for data storage and programmed under control of the end application.
- Internal fixed boot ROM, containing low-level In-Application Programming (IAP) routines that can be called from the end application (in addition to IAP-Lite).
- Default serial loader providing In-System Programming (ISP) via the serial port, located in upper end of user program memory.
- Boot vector allows user-provided Flash loader code to reside anywhere in the Flash memory space, providing flexibility to the user.
- Programming and erase over the full operating voltage range.
- Read/Programming/Erase using ISP/IAP/IAP-Lite.
- Any flash program or erase operation in 2 ms.
- Programmable security for the code in the Flash for each sector.
- >100,000 typical erase/program cycles for each byte.
- 10 year minimum data retention.

8.24.3 ISP and IAP capabilities of the P89LPC920/921/922/9221

Flash organization: The P89LPC920/921/922/9221 program memory consists of two/four/eight 1 kB sectors. Each sector can be further divided into 64-byte pages. In addition to sector erase, page erase, and byte erase, a 64-byte page register is included which allows from 1 to 64 bytes of a given page to be programmed at the same time, substantially reducing overall programming time. An In-Application Programming (IAP) interface is provided to allow the end user's application to erase and reprogram the user code memory. In addition, erasing and reprogramming of user-programmable bytes including UCFG1, the Boot Status Bit and the Boot Vector are supported. As shipped from the factory, the upper 512 bytes of user code space contains a serial In-System Programming (ISP) routine allowing for the device to be programmed in circuit through the serial port.

Flash programming and erasing: There are three methods of erasing or programming of the Flash memory that may be used. First, the Flash may be programmed or erased in the end-user application by calling low-level routines through a common entry point. Second, the on-chip ISP boot loader may be invoked. This ISP boot loader will, in turn, call low-level routines through the same common entry point that can be used by the end-user application. Third, the Flash may be programmed or erased using the parallel method by using a commercially available EPROM programmer which supports this device. This device does not provide for direct verification of code memory contents. Instead this device provides a 32-bit CRC result on either a sector or the entire 2 kB/4 kB/8 kB of user code space.

Boot ROM: When the microcontroller programs its own Flash memory, all of the low-level details are handled by code that is contained in a Boot ROM that is separate from the Flash memory. A user program simply calls the common entry point in the Boot ROM with appropriate parameters to accomplish the desired operation. The Boot ROM include operations such as erase sector, erase page, program page, CRC, program security bit, etc. The Boot ROM occupies the program memory space at the top of the address space from FF00H to FFFFH, thereby not conflicting with the user program memory space.

Power-on reset code execution: The P89LPC920/921/922/9221 contains two special Flash elements: the Boot Vector and the Boot Status Bit. Following reset, the P89LPC920/921/922/9221 examines the contents of the Boot Status Bit. If the Boot Status Bit is set to zero, power-up execution starts at location 0000H, which is the normal start address of the user's application code. When the Boot Status Bit is set to a one, the contents of the Boot Vector is used as the high byte of the execution address and the low byte is set to 00H. The factory default setting is 1FH for the P89LPC9221 and P89LPC922, and corresponds to the address 1F00H for the default ISP boot loader. The factory default setting is 0FH for the P89LPC921 and corresponds to the address 0F00H for the default ISP boot loader. The factory default setting for the LPC920 is 07H and corresponds to the address 0700H. This boot loader is pre-programmed at the factory into this address space and can be erased by the user. **Users who wish to use this loader should take precautions to avoid erasing the 1 kB sector from 1C00H to 1FFFH in the P89LPC922/9221 or the 1 kB sector from 0C00H to 0FFFH in the P89LPC921, or the 1 kB sector from 0400H to 07FFFH in the P89LPC920. Instead, the page erase function can be used to erase the eight 64-byte pages which comprise the lower 512 bytes of the sector.** A custom boot loader can be written with the Boot Vector set to the custom boot loader, if desired.

Hardware activation of the boot loader: The boot loader can also be executed by forcing the device into ISP mode during a power-on sequence (see the *P89LPC920/921/922/9221 User's Manual* for specific information). This has the same effect as having a non-zero Boot Status Bit. This allows an application to be built that will normally execute user code but can be manually forced into ISP operation. If the factory default setting for the Boot Vector is changed, it will no longer point to the factory pre-programmed ISP boot loader code. If this happens, the only way it is possible to change the contents of the Boot Vector is through the parallel programming method, provided that the end user application does not contain a customized loader that provides for erasing and reprogramming of the Boot Vector

and Boot Status Bit. After programming the Flash, the Boot Status Bit should be programmed to zero in order to allow execution of the user's application code beginning at address 0000H.

In-System Programming (ISP): In-System Programming is performed without removing the microcontroller from the system. The In-System Programming facility consists of a series of internal hardware resources coupled with internal firmware to facilitate remote programming of the P89LPC920/921/922/9221 through the serial port. This firmware is provided by Philips and embedded within each P89LPC920/921/922/9221 device. The Philips In-System Programming facility has made in-system programming in an embedded application possible with a minimum of additional expense in components and circuit board area. The ISP function uses five pins (V_{DD} , V_{SS} , TXD, RXD, and \overline{RST}). Only a small connector needs to be available to interface your application to an external circuit in order to use this feature. Please see the *P89LPC920/921/922/9221 User's Manual* for additional details.

In-Application Programming (IAP): Several In-Application Programming (IAP) calls are available for use by an application program to permit selective erasing and programming of Flash sectors, pages, security bits, configuration bytes, and device identification. All calls are made through a common interface, PGM_MTP. The programming functions are selected by setting up the microcontroller's registers before making a call to PGM_MTP at FF00H. Please see the *P89LPC920/921/922/9221 User's Manual* for additional details.

In-Circuit Programming (ICP): In-Circuit Programming is a method intended to allow commercial programmers to program and erase these devices without removing the microcontroller from the system. The In-Circuit Programming facility consists of a series of internal hardware resources to facilitate remote programming of the P89LPC920/921/922/9221 through a two-wire serial interface. Philips has made in-circuit programming in an embedded application possible with a minimum of additional expense in components and circuit board area. The ICP function uses five pins (V_{DD} , V_{SS} , P0.5, P0.4, and \overline{RST}). Only a small connector needs to be available to interface your application to an external programmer in order to use this feature.

8.25 User configuration bytes

A number of user-configurable features of the P89LPC920/921/922/9221 must be defined at power-up and therefore cannot be set by the program after start of execution. These features are configured through the use of the Flash byte UCFG1. Please see the *P89LPC920/921/922/9221 User's Manual* for additional details.

8.26 User sector security bytes

There are two/four/eight User Sector Security Bytes, each corresponding to one sector. Please see the *P89LPC920/921/922/9221 User's Manual* for additional details.

9. Limiting values

Table 7: Limiting values^[1]

In accordance with the Absolute Maximum Rating System (IEC 60134).

Symbol	Parameter	Conditions	Min	Max	Unit
$T_{amb(bias)}$	operating bias ambient temperature		-55	+125	°C
T_{stg}	storage temperature range		-65	+150	°C
V_{xtal}	voltage on XTAL1, XTAL2 pin to V_{SS}		-	$V_{DD} + 0.5$	V
V_n	voltage on any other pin to V_{SS}		-0.5	+5.5	V
$I_{OH(I/O)}$	HIGH-level output current per I/O pin, P89LPC9221	P0.3 to P0.7, P1.4, P1.6, P1.7	-	20	mA
		all other I/O pins	-	8	mA
	HIGH-level output current per I/O pin, P89LPC920/921/922	-	8	mA	
$I_{OL(I/O)}$	LOW-level output current per I/O pin		-	20	mA
$I_{I/O(tot)(max)}$	maximum total I/O current, P89LPC9221		-	160	mA
	maximum total I/O current, P89LPC920/921/922		-	80	mA
$P_{tot(pack)}$	total power dissipation per package	based on package heat transfer, not device power consumption	-	1.5	W

[1] The following applies to Limiting values:

- Stresses above those listed under [Table 7](#) may cause permanent damage to the device. This is a stress rating only and functional operation of the device at these or any conditions other than those described in [Table 8 "DC electrical characteristics"](#), [Table 9 "AC characteristics"](#) and [Table 10 "AC characteristics"](#) of this specification are not implied.
- This product includes circuitry specifically designed for the protection of its internal devices from the damaging effects of excessive static charge. Nonetheless, it is suggested that conventional precautions be taken to avoid applying greater than the rated maximum.
- Parameters are valid over operating temperature range unless otherwise specified. All voltages are with respect to V_{SS} unless otherwise noted.

10. Static characteristics

Table 8: DC electrical characteristics

$V_{DD} = 2.4\text{ V to }3.6\text{ V}$ unless otherwise specified.

$T_{amb} = -40\text{ °C to }+85\text{ °C}$ for industrial, unless otherwise specified.

Symbol	Parameter	Conditions	Min	Typ ^[1]	Max	Unit
$I_{DD(oper)}$	power supply current, operating	3.6 V; 12 MHz	[2] -	9	15	mA
		3.6 V; 18 MHz	[2] -	11.5	20	mA
$I_{DD(idle)}$	power supply current, Idle mode	3.6 V; 12 MHz	[2] -	3.25	5	mA
		3.6 V; 18 MHz	[2] -	5	7	mA
$I_{DD(PD)}$	power supply current, Power-down mode, voltage comparators powered-down	3.6 V	[2] -	55	80	μA
$I_{DD(TPD)}$	power supply current, Total Power-down mode	3.6 V	[2] -	1	5	μA
$(dV_{DD}/dt)_r$	V_{DD} rise rate		-	-	2	$\text{mV}/\mu\text{s}$
$(dV_{DD}/dt)_f$	V_{DD} fall rate		-	-	50	$\text{mV}/\mu\text{s}$
V_{POR}	Power-on reset detect voltage		-	-	0.2	V
V_{RAM}	RAM keep-alive voltage		1.5	-	-	V
$V_{th(HL)}$	negative-going threshold voltage	except SCL, SDA	$0.22V_{DD}$	$0.4V_{DD}$	-	V
V_{IL}	LOW-level input voltage	SCL, SDA only	-0.5	-	$0.3V_{DD}$	V
$V_{th(LH)}$	positive-going threshold voltage	except SCL, SDA	-	$0.6V_{DD}$	$0.7V_{DD}$	V
V_{IH}	HIGH-level input voltage	SCL, SDA only	$0.7V_{DD}$	-	5.5	V
V_{hys}	hysteresis voltage	Port 1	-	$0.2V_{DD}$	-	V
V_{OL}	LOW-level output voltage; all ports, all modes except Hi-Z ^[3]	$I_{OL} = 20\text{ mA}$	-	0.6	1.0	V
		$I_{OL} = 3.2\text{ mA}$	-	0.2	0.3	V
V_{OH}	HIGH-level output voltage	$I_{OH} = -20\text{ mA}$; push-pull mode P0.3 to P0.7, P1.4, P1.6, P1.7	$0.8V_{DD}$	-	-	V
		$I_{OH} = -3.2\text{ mA}$; push-pull mode, all other ports	$V_{DD} - 0.7$	$V_{DD} - 0.4$	-	V
		$I_{OH} = -20\text{ }\mu\text{A}$; quasi-bidirectional mode, all ports	$V_{DD} - 0.3$	$V_{DD} - 0.2$	-	V
C_{ig}	input/output pin capacitance		[4] -	-	15	pF
I_{IL}	logical 0 input current, all ports	$V_{IN} = 0.4\text{ V}$	[5] -	-	-80	μA
I_{LI}	input leakage current, all ports	$V_{IN} = V_{IL}$ or V_{IH}	[6] -	-	± 10	μA
I_{TL}	logical 1-to-0 transition current, all ports	$V_{IN} = 2.0\text{ V}$ at $V_{DD} = 3.6\text{ V}$	[7], [8] -30	-	-450	μA
R_{RST}	internal reset pull-up resistor		10	-	30	$\text{k}\Omega$

Table 8: DC electrical characteristics...continued $V_{DD} = 2.4\text{ V to }3.6\text{ V unless otherwise specified.}$ $T_{amb} = -40\text{ °C to }+85\text{ °C for industrial, unless otherwise specified.}$

Symbol	Parameter	Conditions	Min	Typ ^[1]	Max	Unit
V_{BO}	brownout trip voltage with BOV = '0', BOPD = '1'	$2.4\text{ V} < V_{DD} < 3.6\text{ V}$	2.40	-	2.70	V
V_{REF}	bandgap reference voltage		1.11	1.23	1.34	V
$TC_{(V_{REF})}$	bandgap temperature coefficient		-	10	20	ppm/°C

- [1] Typical ratings are not guaranteed. The values listed are at room temperature, 3 V.
- [2] The $I_{DD(oper)}$, $I_{DD(idle)}$, and $I_{DD(PD)}$ specifications are measured using an external clock with the following functions disabled: comparators, brownout detect, and Watchdog timer.
- [3] See [Table 7 "Limiting values^{\[1\]}" on page 35](#) for steady state (non-transient) limits on I_{OL} or I_{OH} . If I_{OL}/I_{OH} exceeds the test condition, V_{OL}/V_{OH} may exceed the related specification.
- [4] Pin capacitance is characterized but not tested.
- [5] Measured with port in quasi-bidirectional mode.
- [6] Measured with port in high-impedance mode.
- [7] Ports in quasi-bidirectional mode with weak pull-up (applies to all port pins with pull-ups). Does not apply to open-drain pins.
- [8] Port pins source a transition current when used in quasi-bidirectional mode and externally driven from '1' to '0'. This current is highest when V_{IN} is approximately 2 V.

11. Dynamic characteristics

Table 9: AC characteristics

$V_{DD} = 2.4\text{ V to }3.6\text{ V}$ unless otherwise specified.

$T_{amb} = -40\text{ °C to }+85\text{ °C}$ for industrial, unless otherwise specified.^[1]

Symbol	Parameter	Conditions	Variable clock		$f_{osc} = 12\text{ MHz}$		Unit
			Min	Max	Min	Max	
f_{RCOSC}	internal RC oscillator frequency (nominal $f = 7.3728\text{ MHz}$)	trimmed to $\pm 1\%$ at $T_{amb} = 25\text{ °C}$	7.189	7.557	7.189	7.557	MHz
f_{WDOSC}	internal Watchdog oscillator frequency (nominal $f = 400\text{ kHz}$)		320	520	320	520	kHz
f_{osc}	oscillator frequency		0	12	-	-	MHz
t_{CLCL}	clock cycle	see Figure 13	83	-	-	-	ns
f_{CLKP}	CLKLP active frequency		0	8	-	-	MHz

Glitch filter

	glitch rejection, P1.5/ \overline{RST} pin		-	50	-	50	ns
	signal acceptance, P1.5/ \overline{RST} pin		125	-	125	-	ns
	glitch rejection, any pin except P1.5/ \overline{RST}		-	15	-	15	ns
	signal acceptance, any pin except P1.5/ \overline{RST}		50	-	50	-	ns

External clock

t_{CHCX}	HIGH time	see Figure 13	33	$t_{CLCL} - t_{CLCX}$	33	-	ns
t_{CLCX}	LOW time	see Figure 13	33	$t_{CLCL} - t_{CHCX}$	33	-	ns
t_{CLCH}	rise time	see Figure 13	-	8	-	8	ns
t_{CHCL}	fall time	see Figure 13	-	8	-	8	ns

Shift register (UART mode 0)

t_{XLXL}	serial port clock cycle time		$16 t_{CLCL}$	-	1333	-	ns
t_{QVXH}	output data set-up to clock rising edge		$13 t_{CLCL}$	-	1083	-	ns
t_{XHQX}	output data hold after clock rising edge		-	$t_{CLCL} + 20$	-	103	ns
t_{XHDX}	input data hold after clock rising edge		-	0	-	0	ns
t_{DVXH}	input data valid to clock rising edge		150	-	150	-	ns

[1] Parameters are valid over operating temperature range unless otherwise specified. Parts are tested to 2 MHz, but are guaranteed to operate down to 0 Hz.

Table 10: AC characteristics $V_{DD} = 3.0\text{ V to }3.6\text{ V}$ unless otherwise specified. $T_{amb} = -40\text{ °C to }+85\text{ °C}$ for industrial, unless otherwise specified.^[1]

Symbol	Parameter	Conditions	Variable clock		$f_{osc} = 18\text{ MHz}$		Unit
			Min	Max	Min	Max	
f_{RCOSC}	internal RC oscillator frequency (nominal $f = 7.3728\text{ MHz}$)	trimmed to $\pm 1\%$ at $T_{amb} = 25\text{ °C}$	7.189	7.557	7.189	7.557	MHz
f_{WDOSC}	internal Watchdog oscillator frequency (nominal $f = 400\text{ kHz}$)		320	520	320	520	kHz
f_{osc}	oscillator frequency	[2]	0	18	-	-	MHz
t_{CLCL}	clock cycle	see Figure 13	55	-	-	-	ns
f_{CLKP}	CLKLP active frequency		0	8	-	-	MHz
Glitch filter							
	glitch rejection, P1.5/ \overline{RST} pin		-	50	-	50	ns
	signal acceptance, P1.5/ \overline{RST} pin		125	-	125	-	ns
	glitch rejection, any pin except P1.5/ \overline{RST}		-	15	-	15	ns
	signal acceptance, any pin except P1.5/ \overline{RST}		50	-	50	-	ns
External clock							
t_{CHCX}	HIGH time	see Figure 13	22	$t_{CLCL} - t_{CLCX}$	22	-	ns
t_{CLCX}	LOW time	see Figure 13	22	$t_{CLCL} - t_{CHCX}$	22	-	ns
t_{CLCH}	rise time	see Figure 13	-	5	-	5	ns
t_{CHCL}	fall time	see Figure 13	-	5	-	5	ns
Shift register (UART mode 0)							
t_{XLXL}	serial port clock cycle time		16 t_{CLCL}	-	888	-	ns
t_{QVXH}	output data set-up to clock rising edge		13 t_{CLCL}	-	722	-	ns
t_{XHQX}	output data hold after clock rising edge		-	$t_{CLCL} + 20$	-	75	ns
t_{XHDX}	input data hold after clock rising edge		-	0	-	0	ns
t_{DVXH}	input data valid to clock rising edge		150	-	150	-	ns

[1] Parameters are valid over operating temperature range unless otherwise specified. Parts are tested to 2 MHz, but are guaranteed to operate down to 0 Hz.

[2] When using an oscillator frequency above 12 MHz, the reset input function of P1.5 must be enabled. An external circuit is required to hold the device in reset at power-up until V_{DD} has reached its specified level. When system power is removed V_{DD} will fall below the minimum specified operating voltage. When using an oscillator frequency above 12 MHz, in some applications, an external brownout detect circuit may be required to hold the device in reset when V_{DD} falls below the minimum specified operating voltage.

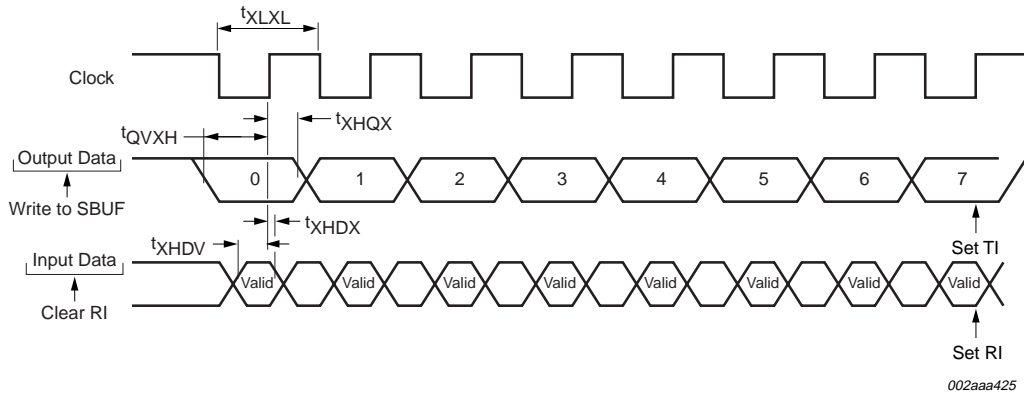

Fig 12. Shift register mode timing.

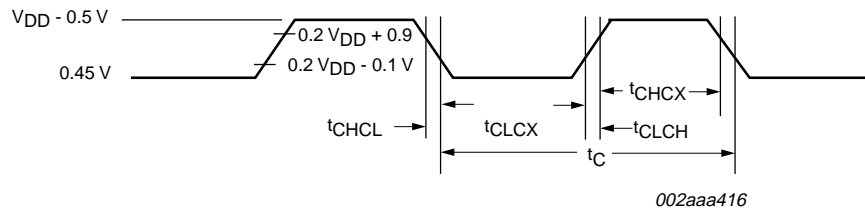

Fig 13. External clock timing.

Table 11: AC characteristics, ISP entry mode

$V_{DD} = 2.4V$ to $3.6V$, unless otherwise specified.

$T_{amb} = -40^{\circ}C$ to $+85^{\circ}C$ for industrial, unless otherwise specified.

Symbol	Parameter	Conditions	Min	Typ	Max	Unit
t_{VR}	\overline{RST} delay from V_{DD} active		50	-	-	μs
t_{RH}	\overline{RST} HIGH time		1	-	32	μs
t_{RL}	\overline{RST} LOW time		1	-	-	μs

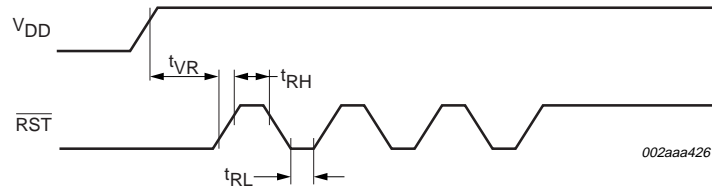

Fig 14. ISP entry waveform.

12. Comparator electrical characteristics

Table 12: Comparator electrical characteristics

$V_{DD} = 2.4\text{ V to }3.6\text{ V}$, unless otherwise specified.

$T_{amb} = -40\text{ }^{\circ}\text{C to }+85\text{ }^{\circ}\text{C}$ for industrial, unless otherwise specified.

Symbol	Parameter	Conditions	Min	Typ	Max	Unit
V_{IO}	offset voltage comparator inputs		-	-	± 20	mV
V_{CR}	common mode range comparator inputs		0	-	$V_{DD} - 0.3$	V
CMRR	common mode rejection ratio		[1] -	-	-50	dB
	response time		-	250	500	ns
	comparator enable to output valid		-	-	10	μs
I_{IL}	input leakage current, comparator	$0 < V_{IN} < V_{DD}$	-	-	± 10	μA

[1] This parameter is characterized, but not tested in production.

13. Package outline

TSSOP20: plastic thin shrink small outline package; 20 leads; body width 4.4 mm

SOT360-1

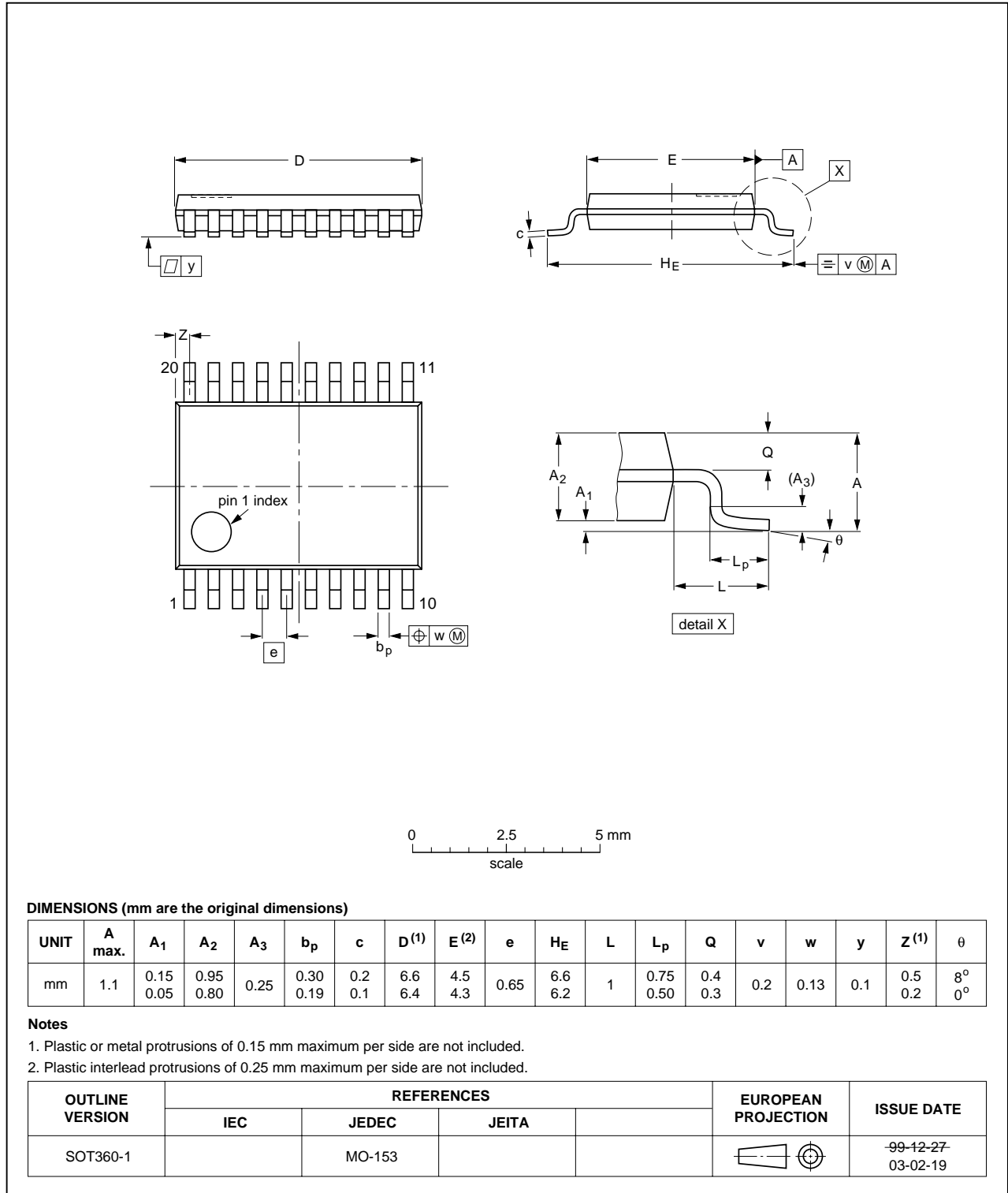

Fig 15. TSSOP20 (SOT360-1).

DIP20: plastic dual in-line package; 20 leads (300 mil)

SOT146-1

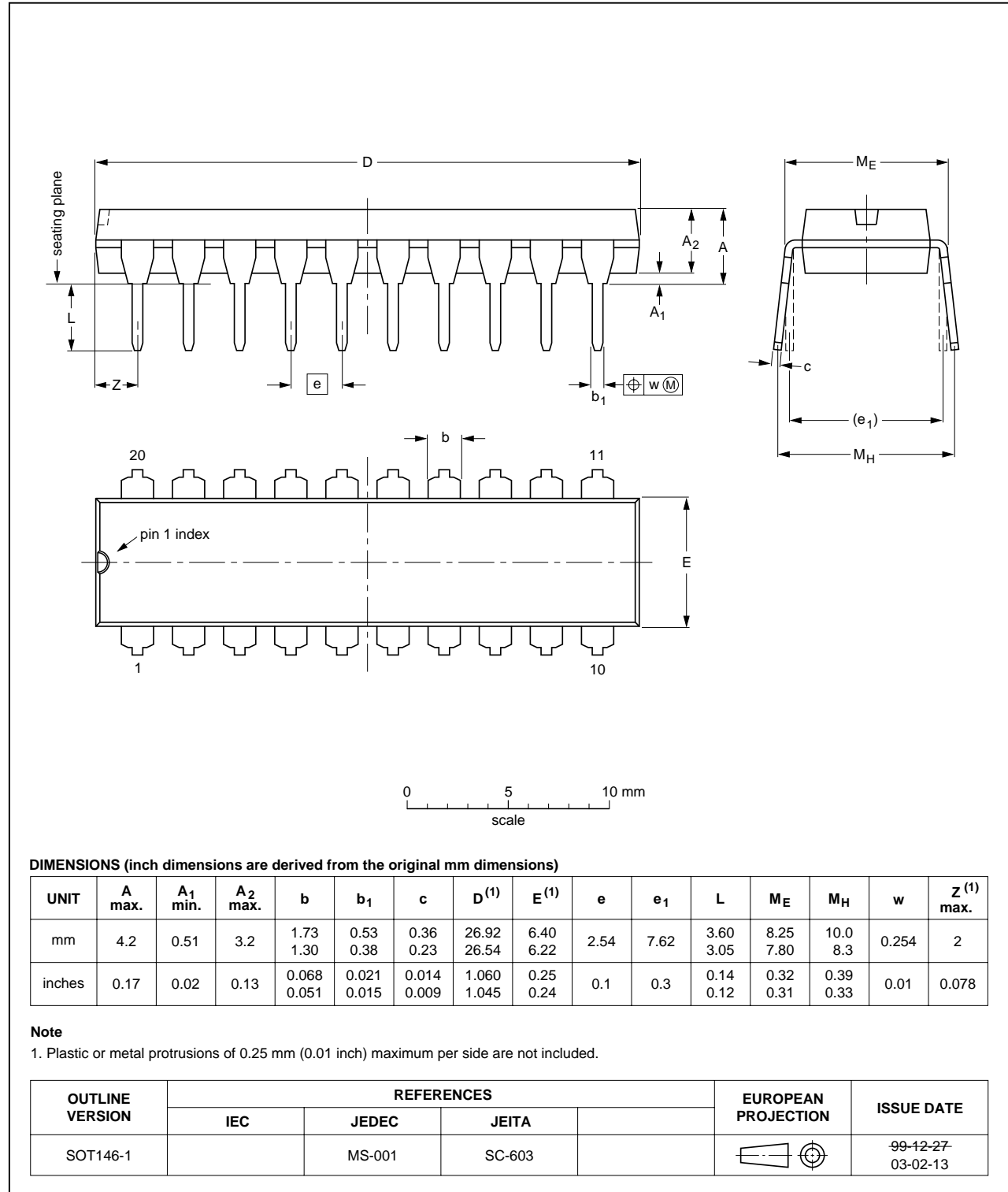

Fig 16. DIP20 (SOT146-1).

14. Revision history

Table 13: Revision history

Rev	Date	CPCN	Description
08	20041215	-	Product data (9397 750 14469) Modification: <ul style="list-style-type: none">• Added 18 MHz information.
07	20041203	-	Product data (9397 750 14251)
06	20031121	-	Product data (9397 750 12285); ECN 853-2403 01-A14557 of 18 November 2003
05	20031007	-	Product data (9397 750 12121); ECN 853-2403 30391 of 30 September 2003
04	20030909	-	Product data (9397 750 11945); ECN 853-2403 30305 of 5 September 2003
03	20030811	-	Preliminary data (9397 750 11786)
02	20030522	-	Objective data (9397 750 11532)
01	20030505	-	Preliminary data (9397 750 11387)

15. Data sheet status

Level	Data sheet status ^[1]	Product status ^{[2][3]}	Definition
I	Objective data	Development	This data sheet contains data from the objective specification for product development. Philips Semiconductors reserves the right to change the specification in any manner without notice.
II	Preliminary data	Qualification	This data sheet contains data from the preliminary specification. Supplementary data will be published at a later date. Philips Semiconductors reserves the right to change the specification without notice, in order to improve the design and supply the best possible product.
III	Product data	Production	This data sheet contains data from the product specification. Philips Semiconductors reserves the right to make changes at any time in order to improve the design, manufacturing and supply. Relevant changes will be communicated via a Customer Product/Process Change Notification (CPCN).

[1] Please consult the most recently issued data sheet before initiating or completing a design.

[2] The product status of the device(s) described in this data sheet may have changed since this data sheet was published. The latest information is available on the Internet at URL <http://www.semiconductors.philips.com>.

[3] For data sheets describing multiple type numbers, the highest-level product status determines the data sheet status.

16. Definitions

Short-form specification — The data in a short-form specification is extracted from a full data sheet with the same type number and title. For detailed information see the relevant data sheet or data handbook.

Limiting values definition — Limiting values given are in accordance with the Absolute Maximum Rating System (IEC 60134). Stress above one or more of the limiting values may cause permanent damage to the device. These are stress ratings only and operation of the device at these or at any other conditions above those given in the Characteristics sections of the specification is not implied. Exposure to limiting values for extended periods may affect device reliability.

Application information — Applications that are described herein for any of these products are for illustrative purposes only. Philips Semiconductors make no representation or warranty that such applications will be suitable for the specified use without further testing or modification.

customers using or selling these products for use in such applications do so at their own risk and agree to fully indemnify Philips Semiconductors for any damages resulting from such application.

Right to make changes — Philips Semiconductors reserves the right to make changes in the products - including circuits, standard cells, and/or software - described or contained herein in order to improve design and/or performance. When the product is in full production (status 'Production'), relevant changes will be communicated via a Customer Product/Process Change Notification (CPCN). Philips Semiconductors assumes no responsibility or liability for the use of any of these products, conveys no licence or title under any patent, copyright, or mask work right to these products, and makes no representations or warranties that these products are free from patent, copyright, or mask work right infringement, unless otherwise specified.

18. Licenses

Purchase of Philips I²C components



Purchase of Philips I²C components conveys a license under the Philips' I²C patent to use the components in the I²C system provided the system conforms to the I²C specification defined by Philips. This specification can be ordered using the code 9398 393 40011.

17. Disclaimers

Life support — These products are not designed for use in life support appliances, devices, or systems where malfunction of these products can reasonably be expected to result in personal injury. Philips Semiconductors

Contact information

For additional information, please visit <http://www.semiconductors.philips.com>.

For sales office addresses, send e-mail to: sales.addresses@www.semiconductors.philips.com.

Fax: +31 40 27 24825

Contents

1	General description	1	8.16.5	Mode 6	24
2	Features	1	8.16.6	Timer overflow toggle output	24
2.1	Principal features	1	8.17	Real-Time clock/system timer	24
2.2	Additional features	2	8.18	UART	24
3	Ordering information	3	8.18.1	Mode 0	24
3.1	Ordering options	3	8.18.2	Mode 1	25
4	Block diagram	4	8.18.3	Mode 2	25
5	Pinning information	5	8.18.4	Mode 3	25
5.1	Pinning	5	8.18.5	Baud rate generator and selection	25
5.2	Pin description	6	8.18.6	Framing error	25
6	Logic symbol	8	8.18.7	Break detect	26
7	Special function registers	9	8.18.8	Double buffering	26
8	Functional description	14	8.18.9	Transmit interrupts with double buffering enabled (Modes 1, 2 and 3)	26
8.1	Enhanced CPU	14	8.18.10	The 9 th bit (bit 8) in double buffering (Modes 1, 2 and 3)	26
8.2	Clocks	14	8.19	I ² C-bus serial interface	27
8.2.1	Clock definitions	14	8.20	Analog comparators	29
8.2.2	CPU clock (OSCCLK)	14	8.20.1	Internal reference voltage	29
8.2.3	Low speed oscillator option	14	8.20.2	Comparator interrupt	30
8.2.4	Medium speed oscillator option	14	8.20.3	Comparators and power reduction modes	30
8.2.5	High speed oscillator option	14	8.21	Keypad interrupt (KBI)	30
8.2.6	Clock output	15	8.22	Watchdog timer	31
8.3	On-chip RC oscillator option	15	8.23	Additional features	31
8.4	Watchdog oscillator option	15	8.23.1	Software reset	31
8.5	External clock input option	15	8.23.2	Dual data pointers	31
8.6	CPU Clock (CCLK) wake-up delay	17	8.24	Flash program memory	32
8.7	CPU Clock (CCLK) modification: DIVM register	17	8.24.1	General description	32
8.8	Low power select	17	8.24.2	Features	32
8.9	Memory organization	17	8.24.3	ISP and IAP capabilities of the P89LPC920/921/922/9221	32
8.10	Data RAM arrangement	18	8.25	User configuration bytes	34
8.11	Interrupts	18	8.26	User sector security bytes	34
8.11.1	External interrupt inputs	18	9	Limiting values	35
8.12	I/O ports	19	10	Static characteristics	36
8.12.1	Port configurations	19	11	Dynamic characteristics	38
8.12.2	Quasi-bidirectional output configuration	20	12	Comparator electrical characteristics	41
8.12.3	Open-drain output configuration	20	13	Package outline	42
8.12.4	Input-only configuration	20	14	Revision history	44
8.12.5	Push-pull output configuration	20	15	Data sheet status	45
8.12.6	Port 0 analog functions	20	16	Definitions	45
8.12.7	Additional port features	21	17	Disclaimers	45
8.13	Power monitoring functions	21	18	Licenses	45
8.13.1	Brownout detection	21			
8.13.2	Power-on detection	21			
8.14	Power reduction modes	21			
8.14.1	Idle mode	22			
8.14.2	Power-down mode	22			
8.14.3	Total Power-down mode	22			
8.15	Reset	22			
8.15.1	Reset vector	23			
8.16	Timers/counters 0 and 1	23			
8.16.1	Mode 0	23			
8.16.2	Mode 1	23			
8.16.3	Mode 2	24			
8.16.4	Mode 3	24			



PHILIPS

Let's make things better.

Looking for pricing, stock, or lifecycle information?

Click below to explore more details on WIN SOURCE:

 [View P89LPC921FDH on WIN SOURCE](#)

 [NXP / Nexperia Information](#)

Optimize Your Supply Chain with WIN SOURCE Solutions

-  Global Sourcing Solution
-  Obsolete Management
-  Cost Control Management
-  Shortage Management
-  Alternative Solution
-  Excess Inventory Management