



**THE DATASHEET OF  
PACSZ128402QR**



# PACSZ1284

## IEEE 1284 Parallel Port ESD/EMI/Termination Network

### Product Description

The PACSZ1284 combines EMI filtering, ESD protection, and signal termination in a single QSOP package for parallel port interfaces complying to the IEEE 1284 standard.

The PACSZ1284 provides a complete parallel port termination solution. It integrates the equivalent of 60 discrete components, making it ideal for space critical applications. The pins of the device which connect to the parallel port are protected to  $\pm 30$  kV contact discharge, well beyond Level 4 of the IEC 61000-4-2 specification. All other pins are ESD-protected for contact discharges up to  $\pm 8$  kV per IEC 61000-4-2.

There are two values available for pull-up resistor R1. For the PACSZ1284-02, R1 = 2.2 k $\Omega$ ; for the PACSZ1284-04, R1 = 4.7 k $\Omega$ .

The PACSZ1284 is housed in a 28-pin QSOP package and is available with RoHS compliant lead-free finishing.

### Features

- 17 EMI Filters
- 17 ESD Protectors Yielding Protection to 30 kV Contact Discharge, per IEC 61000-4-2 Specification
- 17 Terminators with Choice of Resistor Values
- 28-Pin QSOP Package
- These Devices are Pb-Free and are RoHS Compliant

### Applications

- Parallel Ports of PCs, Printers, Peripherals, and Set-Top Boxes



ON Semiconductor®

<http://onsemi.com>

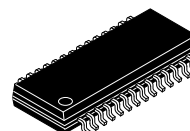

QSOP-28  
QR SUFFIX  
CASE 492AA

### MARKING DIAGRAM

PACSZ1284 02QR

PACSZ1284 02QR = Specific Device Code

PACSZ128404QR

PACSZ128404QR = Specific Device Code

### ORDERING INFORMATION

Device	Package	Shipping†
PACSZ1284-02QR	QSOP-28 (Pb-Free)	2500/Tape & Reel
PACSZ1284-04QR	QSOP-28 (Pb-Free)	2500/Tape & Reel

†For information on tape and reel specifications, including part orientation and tape sizes, please refer to our Tape and Reel Packaging Specification Brochure, BRD8011/D.

# PACSZ1284

## ELECTRICAL SCHEMATIC

PACSZ1284-02
R1 = 2.2 kΩ
R2 = 33 Ω
C = 150 pF

PACSZ1284-04
R1 = 4.7 kΩ
R2 = 33 Ω
C = 150 pF

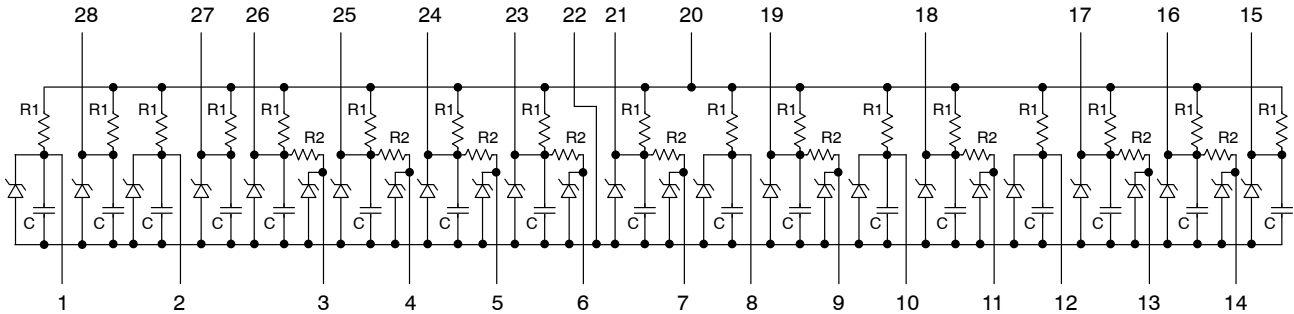

## PACKAGE / PINOUT DIAGRAMS

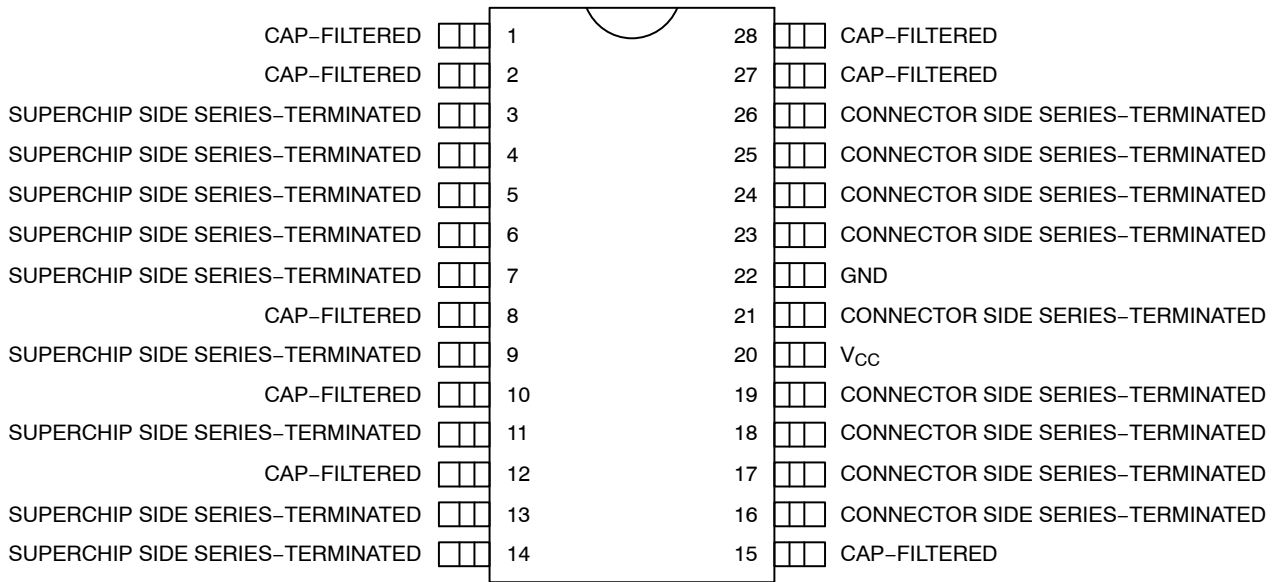

28-Pin QSOP

Table 1. PIN DESCRIPTIONS

Leads	Name	Description
1, 2, 8, 10, 12, 15, 27, 28	Capacitor-Filtered	IEEE 1284 Signals which Require No Series Termination
3-7, 9, 11, 13, 14	Super I/O Chip Side Series-Terminated	IEEE 1284 Signals on the Super I/O Chip Side which Require Series Termination
16-19, 21, 23-26	Parallel Port Connector Side Series-Terminated	IEEE 1284 Signals on the Parallel Port Connector Side which Require Series Termination
20	V <sub>CC</sub>	Supply Rail for the Device
22	GND	Ground Reference for the Device

# PACSZ1284

## SPECIFICATIONS

**Table 2. ABSOLUTE MAXIMUM RATINGS**

Parameter	Rating	Units
V <sub>CC</sub> Voltage	5.5	V
Input Voltage Range, No Clamping	-0.4 to 5.5	V
Storage Temperature Range	-40 to +150	°C
Power Dissipation per Resistor	0.1	W
Package Power Dissipation	1.0	W

Stresses exceeding Maximum Ratings may damage the device. Maximum Ratings are stress ratings only. Functional operation above the Recommended Operating Conditions is not implied. Extended exposure to stresses above the Recommended Operating Conditions may affect device reliability.

**Table 3. STANDARD OPERATING CONDITIONS**

Parameter	Rating	Units
V <sub>CC</sub> Voltage	5.0	V
Operating Temperature	-40 to +85	°C

**Table 4. ELECTRICAL OPERATING CHARACTERISTICS**

Symbol	Parameter	Conditions	Min	Typ	Max	Units
TOL <sub>R</sub>	Absolute Resistance Tolerance	Measured at T <sub>A</sub> = 25°C			±20	%
TOL <sub>C</sub>	Absolute Capacitance Tolerance	Measured at 1 MHz, 2.5 VDC, T <sub>A</sub> = 25°C			±20	%
I <sub>LEAK</sub>	Leakage Current to GND	Measured at 5.0 VDC, T <sub>A</sub> = 25°C		1	10	µA
V <sub>ESDi</sub>	ESD Protection, Input Pins	Pins 3, 4, 5, 6, 7, 9, 11, 13, & 14, per IEC 61000-4-2 Specification (Notes 1 and 2)	±8			kV
V <sub>ESD</sub>	ESD Protection, Connector Pins	Pins 1, 2, 8, 10, 12, 15, 16, 17, 18, 19, 21, 23, 24, 25, 26, 27, & 28, per IEC 61000-4-2 Specification (Notes 1 and 3)	±30			kV
V <sub>CLAMP</sub>	Clamping Voltage under ESD Discharge	ESD Applied to Connector Pin, Measured at Corresponding Input Pin; +8 kV Discharge, Human Body Model (Note 1)		8.3		V
		ESD Applied to Connector Pin, Measured at Corresponding Input Pin; -8 kV Discharge, Human Body Model (Note 1)		-2.7		V

- ESD voltage applied between Input/Connector pins and ground, one pin at a time.
- Pins 3-7, 9, 11, 13, and 14 typically connect to the I/O pins of a Super I/O chip.
- Pins 1, 2, 8, 10, 12, 15-19, 21, and 23-28 typically connect to the Parallel Port connector.

# PACSZ1284

## PERFORMANCE INFORMATION

### Filter Capacitors

The IEEE 1284 specification requires both termination and EMI filtering on a total of 17 lines. Basic filtering is provided through the presence of a capacitor on all signal lines. The filter capacitor is the junction capacitance of an ESD diode. The typical capacitance at a reverse voltage of 2.5 V is 150 pF. This diode capacitance is somewhat voltage dependent. See Figure 1.

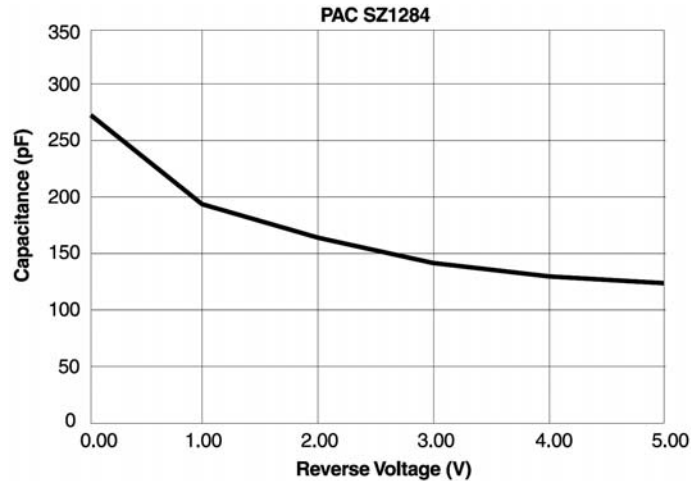

Figure 1. Diode Capacitance vs. Reverse Voltage

The higher speed Data and Strobe lines (9 in total) require an additional series resistor termination for proper operation, while the eight (8) Status lines do not. See Table 5.

### Filter Insertion Loss

Figure 2 shows the typical Insertion Loss graphs of the PACSZ1284 for Data and Strobe signals. The curves are dependent on the physical location of the filter elements with respect to the ground terminal of this device. These graphs are measured in a 50  $\Omega$  environment on a Hewlett Packard HP 8753C Analyzer. The signal source is introduced at the resistor input and the output is measured at the corresponding protection diode. The actual pins measured are labeled in the Figure 2 graph.

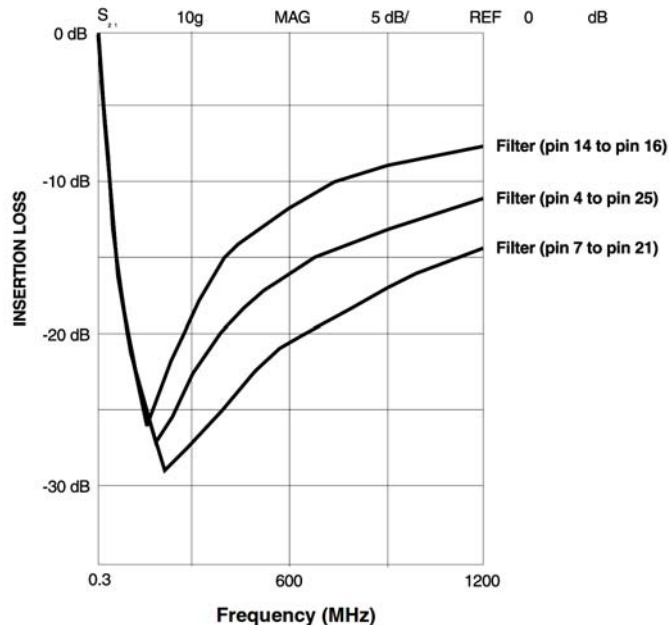

Figure 2. Typical Filter Insertion Loss

# PACSZ1284

## APPLICATION INFORMATION

### Termination Considerations

The IEEE 1284 specification requires both termination and EMI filtering on a total of 17 signal lines. Control and Status lines (8 in total) only require a pull-up resistor and a filter capacitor. The Data lines and Strobe also require a series termination resistor in addition to the pull-up resistors and filter capacitors. See Table 5, in conjunction with the schematic diagram on page 2.

**Table 5. IEEE 1284 TERMINATION REQUIREMENTS**

Signal Termination Requirements	
Signal Name	Series Termination
Data1 – Data8	Yes
Strobe	Yes
Init	Not Required
AutoFeedXT	Not Required
Selectin	Not Required
ACK	Not Required
Busy	Not Required
Paper Empty	Not Required
Select	Not Required
Fault	Not Required

### Interfacing to IEEE 1284 Connectors

IEEE 1284 defines three interface connectors:

- 1284 A is a 25-pin DB series connector which is the de facto PC standard for the host connection
- 1284 B is a 36-pin, 0.085 inch centerline connector used on the peripheral device
- 1284 C is a new 36-pin, 0.050 inch centerline connector which can be used for both host and peripheral

Figure 3A shows a possible hook-up between the 1284-A connector on a PC motherboard and the PACSZ1284, illustrating how the pin configuration of the PACSZ1284 allows for easy interconnect between the two. The dotted I/O signals of the PACSZ1284 will typically be connected to a Super I/O chip on the motherboard.

Figure 3B shows a possible hook-up between the 1284-B connector on a peripheral and the PACSZ1284

Figure 3C shows a possible hook-up between the 1284-C connector and the PACSZ1284.

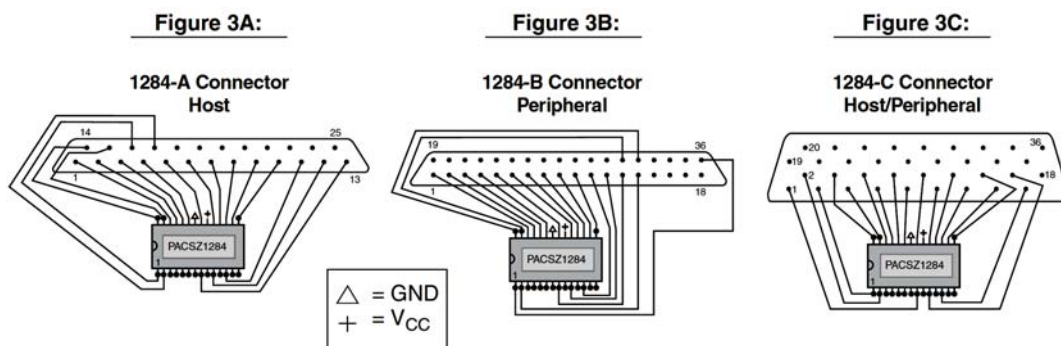

**Figure 3. Example Connections of IEEE 1284 Connectors with PACSZ1284**

Table 6 provides the IEEE 1284 signal assignments for the three connectors, and example PACSZ1284 pin connections.

When connecting a 1284-A host to a 1284-B peripheral, the “Peripheral Logic High” signal is not used. Similarly, when a 1284-A host is connected to a 1284-C peripheral, the “Peripheral Logic High” and “Host Logic High” are not used. These two signals are optionally used to detect a “Power Off” or “Cable Disconnect” state for host and peripheral, respectively.

# PACSZ1284

## APPLICATION INFORMATION (Cont'd)

**Table 6. IEEE 1284 CONNECTOR PINOUTS AND PACSZ1284 CONNECTION GUIDELINES**

PACSZ1284 Pin Type	1284-A 25-Pin DSUB		1284-B 36-Pin Champ		1284-C 36-Pin High Density	
	Signal	Pin	Signal	Pin	Signal	Pin
P-Port Conn. Side, Series-Terminated (16-19, 21, or 23-26)	STROBE	1	STROBE	1	STROBE	15
P-Port Conn. Side, Series-Terminated (16-19, 21, or 23-26)	Data 1	2	Data 1	2	Data 1	6
P-Port Conn. Side, Series-Terminated (16-19, 21, or 23-26)	Data 2	3	Data 2	3	Data 2	7
P-Port Conn. Side, Series-Terminated (16-19, 21, or 23-26)	Data 3	4	Data 3	4	Data 3	8
P-Port Conn. Side, Series-Terminated (16-19, 21, or 23-26)	Data 4	5	Data 4	5	Data 4	9
P-Port Conn. Side, Series-Terminated (16-19, 21, or 23-26)	Data 5	6	Data 5	6	Data 5	10
P-Port Conn. Side, Series-Terminated (16-19, 21, or 23-26)	Data 6	7	Data 6	7	Data 6	11
P-Port Conn. Side, Series-Terminated (16-19, 21, or 23-26)	Data 7	8	Data 7	8	Data 7	12
P-Port Conn. Side, Series-Terminated (16-19, 21, or 23-26)	Data 8	9	Data 8	9	Data 8	13
Capacitor-Filtered (1, 2, 8, 10, 12, 15, 27, or 28)	ACK	10	ACK	10	ACK	3
Capacitor-Filtered (1, 2, 8, 10, 12, 15, 27, or 28)	BUSY	11	BUSY	11	BUSY	1
Capacitor-Filtered (1, 2, 8, 10, 12, 15, 27, or 28)	PError	12	PError	12	PError	5
Capacitor-Filtered (1, 2, 8, 10, 12, 15, 27, or 28)	Select	13	Select	13	Select	2
Capacitor-Filtered (1, 2, 8, 10, 12, 15, 27, or 28)	AUTOFD	14	AUTOFD	14	AUTOFD	17
Capacitor-Filtered (1, 2, 8, 10, 12, 15, 27, or 28)	FAULT	15	FAULT	32	FAULT	4
Capacitor-Filtered (1, 2, 8, 10, 12, 15, 27, or 28)	INIT	16	INIT	31	INIT	14
Capacitor-Filtered (1, 2, 8, 10, 12, 15, 27, or 28)	Selectin	17	Selectin	36	Selectin	16
	Ground	18	Ground	19	Ground	19
	Ground	19	Ground	20	Ground	20
	Ground	20	Ground	21	Ground	21
	Ground	21	Ground	22	Ground	22
	Ground	22	Ground	23	Ground	23
	Ground	23	Ground	24	Ground	24
	Ground	24	Ground	25	Ground	25
	Ground	25	Ground	26	Ground	26
			Ground	27	Ground	27
			Ground	28	Ground	28
			Ground	29	Ground	29
			Ground	30	Ground	30
			Not Defined	33	Ground	31
			Not Defined	34	Ground	32
			Not Defined	35	Ground	33
			Not Defined	15	Ground	34
			Logic Ground	16	Ground	35
			Chassis GND	17	Not Required	36
		Peripheral Logic	18	Host Logic High	18	

# PACSZ1284

## PACKAGE DIMENSIONS

QSOP28 NB  
CASE 492AA-01  
ISSUE 0

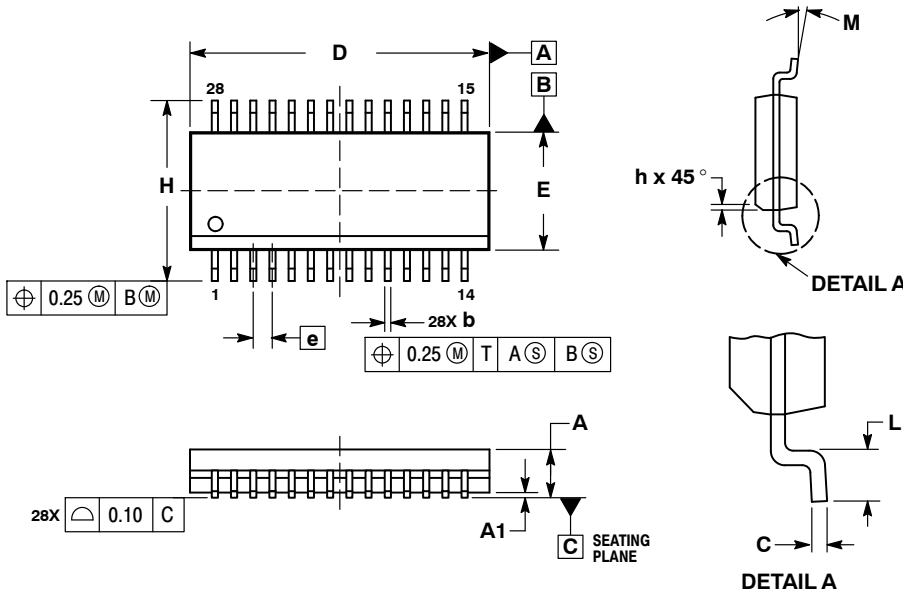

- NOTES:
1. DIMENSIONING AND TOLERANCING PER ASME Y14.5M, 1994.
  2. CONTROLLING DIMENSION: MILLIMETERS.
  3. DIMENSION b DOES NOT INCLUDE DAMBAR PROTRUSION.
  4. DIMENSIONS D AND E DO NOT INCLUDE MOLD PROTRUSIONS OR FLASH. END FLASH SHALL NOT EXCEED 0.25 PER SIDE.

MILLIMETERS		
DIM	MAX	MIN
A	1.35	1.75
A1	0.10	0.25
b	0.20	0.30
C	0.19	0.25
D	9.80	10.00
E	3.80	4.00
e	0.635 BSC	
H	5.79	6.20
h	0.22	0.50
L	0.40	1.27
M	0°	8°

### SOLDERING FOOTPRINT

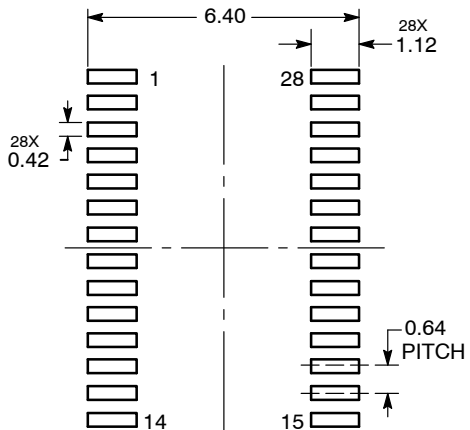

DIMENSIONS: MILLIMETERS

**ON Semiconductor** and are registered trademarks of Semiconductor Components Industries, LLC (SCILLC). SCILLC reserves the right to make changes without further notice to any products herein. SCILLC makes no warranty, representation or guarantee regarding the suitability of its products for any particular purpose, nor does SCILLC assume any liability arising out of the application or use of any product or circuit, and specifically disclaims any and all liability, including without limitation special, consequential or incidental damages. "Typical" parameters which may be provided in SCILLC data sheets and/or specifications can and do vary in different applications and actual performance may vary over time. All operating parameters, including "Typicals" must be validated for each customer application by customer's technical experts. SCILLC does not convey any license under its patent rights nor the rights of others. SCILLC products are not designed, intended, or authorized for use as components in systems intended for surgical implant into the body, or other applications intended to support or sustain life, or for any other application in which the failure of the SCILLC product could create a situation where personal injury or death may occur. Should Buyer purchase or use SCILLC products for any such unintended or unauthorized application, Buyer shall indemnify and hold SCILLC and its officers, employees, subsidiaries, affiliates, and distributors harmless against all claims, costs, damages, and expenses, and reasonable attorney fees arising out of, directly or indirectly, any claim of personal injury or death associated with such unintended or unauthorized use, even if such claim alleges that SCILLC was negligent regarding the design or manufacture of the part. SCILLC is an Equal Opportunity/Affirmative Action Employer. This literature is subject to all applicable copyright laws and is not for resale in any manner.

### PUBLICATION ORDERING INFORMATION

**LITERATURE FULFILLMENT:**  
Literature Distribution Center for ON Semiconductor  
P.O. Box 5163, Denver, Colorado 80217 USA  
**Phone:** 303-675-2175 or 800-344-3860 Toll Free USA/Canada  
**Fax:** 303-675-2176 or 800-344-3867 Toll Free USA/Canada  
**Email:** orderlit@onsemi.com

**N. American Technical Support:** 800-282-9855 Toll Free  
USA/Canada  
**Europe, Middle East and Africa Technical Support:**  
Phone: 421 33 790 2910  
**Japan Customer Focus Center**  
Phone: 81-3-5817-1050

**ON Semiconductor Website:** [www.onsemi.com](http://www.onsemi.com)  
**Order Literature:** <http://www.onsemi.com/orderlit>  
For additional information, please contact your local Sales Representative

## Looking for pricing, stock, or lifecycle information?

Click below to explore more details on WIN SOURCE:

- ⊖ [View PACSZ128402QR](#) on WIN SOURCE
- ⊖ [ON Semiconductor](#) Information

## Optimize Your Supply Chain with WIN SOURCE Solutions

- ✓ Global Sourcing Solution
- ✓ Obsolete Management
- ✓ Cost Control Management
- ✓ Shortage Management
- ✓ Alternative Solution
- ✓ Excess Inventory Management