



**THE DATASHEET OF
PAM3103AABADJ**



Description

The PAM3103 is a positive, adjustable linear regulator. It features low quiescent current (65µA typ.) and low dropout voltage, making it ideal for battery powered applications. The output voltage is adjustable from 1.2V through 5V. Its high PSRR makes it useful in applications that require AC noise suppression on the input power supply. Space-saving SOT23-5 and SOT353(SC70-5) packages are attractive for portable and handheld applications. It has both thermal shutdown and a current limit features to prevent device failure under extreme operating conditions. It is stable with an output capacitor of 2.2µF or greater.

Features

- Low Dropout Voltage: 180mV@ 300mA ($V_O = 3.3V$)
- Accuracy within ±2%
- Quiescent Current: 65µA Typ.
- High PSRR: 67dB@100Hz
- Excellent Line/Load Regulation
- Fast Response
- Current Limiting
- Short Circuit Protection
- Low Temperature Coefficient
- Shutdown Current: 0.5µA
- Thermal Shutdown
- Space Saving Packages SOT23-5 and SOT353(SC70-5)
- Pb-Free Package

Pin Assignments

Top View
SOT23-5

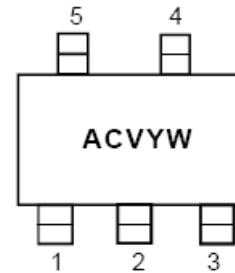

Top View
SOT353(SC70-5)

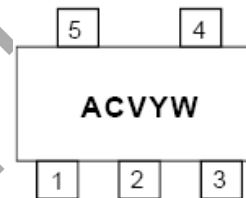

Applications

- Cordless Phone
- Cellular Phone
- Bluetooth Earphone
- Digital Camera
- Portable Electronics
- WLAN
- MP3 Player

Typical Applications Circuit

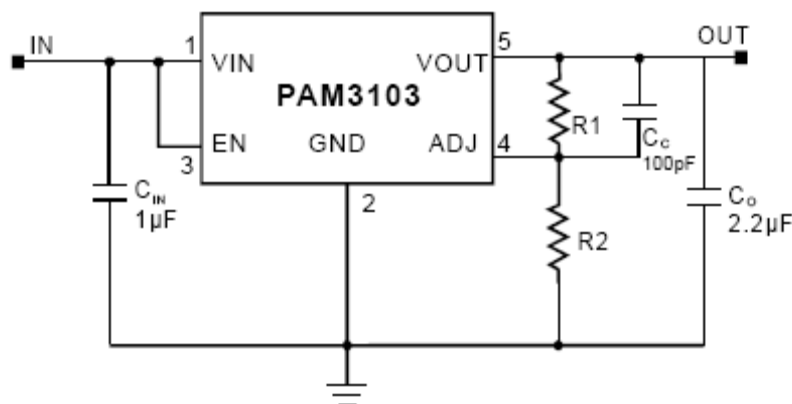

$$V_O = V_{REF} \cdot (R1+R2)/R2$$

Pin Descriptions

Pin Number	Pin Name	Function
1	VIN	Input
2	GND	Ground
3	EN	Chip Enable (Active High)
4	ADJ	Adjustable Pin
5	VOUT	Output

Functional Block Diagram

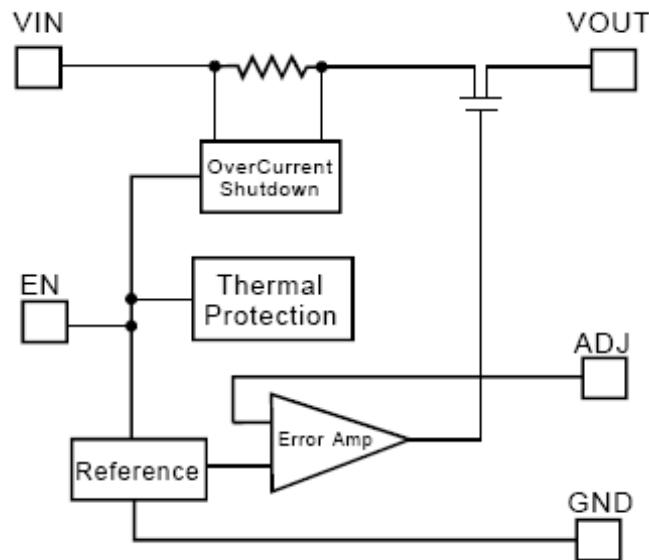

Absolute Maximum Ratings (@T_A = +25°C, unless otherwise specified.)

These are stress ratings only and functional operation is not implied. Exposure to absolute maximum ratings for prolonged time periods may affect device reliability. All voltages are with respect to ground.

Parameter	Rating	Unit
Input Voltage	6.0	V
Output Current	300	mA
Output Pin Voltage	GND -0.3 to V _{IN} +0.3V	V
Lead Soldering Temperature	300	°C
Storage Temperature	-65 to +150	°C

Recommended Operating Conditions (@T_A = +25°C, unless otherwise specified.)

Parameter	Rating	Unit
Supply Voltage Range	2.5 to 5.5	V
Junction Temperature	-40 to +125	°C
Operation Temperature	-40 to +85	

Thermal Information

Parameter	Symbol	Package	Max	Unit
Thermal Resistance Junction to Case)	θ_{JC}	SOT23-5	130	°C/W
		SOT353(SC70-5)	TBD	
Thermal Resistance (Junction to Ambient)	θ_{JA}	SOT23-5	250	
		SOT353(SC70-5)	300	
Internal Power Dissipation	P _D	SOT23-5	400	mW
		SOT353(SC70-5)	300	

Electrical Characteristics (@T_A = +25°C, V_{IN} = 4V, V_O = 3V, C_{IN} = 1μF, C_O = 2.2μF, unless otherwise specified.)

Parameter	Symbol	Test Conditions	Min	Typ	Max	Units	
Input Voltage	V _{IN}	—	Note 1	—	5.5	V	
Output Voltage	V _O	—	1.2	—	5	V	
Reference Voltage	V _{REF}	—	—	1.235	—	V	
Output Voltage Accuracy	V _O	I _O = 1mA	-2	—	2	%	
Output Current	I _O	—	300	—	Note 2	mA	
Short Circuit Current	I _{SC}	V _O = 0V	—	150	—	mA	
Dropout Voltage	V _{DROP}	I _O = 300mA	2.5V ≤ V _O < 3.3V	—	370	450	mV
			V _O ≥ 3.3V	—	180	230	
Ground Current	I _{GND}	I _O = 1mA to 300mA	—	70	90	μA	
Quiescent Current	I _Q	I _O = 0mA	—	65	90	μA	
Line Regulation	LNR	I _O = 1mA, V _{IN} = 3V to 5V	-0.4	0.2	0.4	%/V	
Load Regulation	LDR	I _O = 1mA to 300mA	-1	0.2	1	%	
Temperature Coefficient	T _C	—	—	40	—	ppm/°C	
Over Temperature Shutdown	OTS	I _O = 1mA	—	150	—	°C	
Over Temperature Hysteresis	OTH	I _O = 1mA	—	30	—	°C	
Power Supply Ripple Rejection	PSRR	I _O = 100mA, V _O = 1.2V	f = 100Hz	—	67	—	dB
			f = 1kHz	—	65	—	dB
			f = 10kHz	—	42	—	dB
Output Noise	V _N	f = 10Hz to 100kHz	—	50	—	μV _{RMS}	
EN Input High Threshold	V _{IH}	V _{IN} 2.5V to 5V	1.5	—	—	V	
EN Input Low Threshold	V _{IL}	V _{IN} 2.5V to 5V	—	—	0.3	V	
Shutdown Current	I _{SD}	V _{EN} = 0V	—	0.01	1	μA	

Notes: 1. The minimum input voltage (V_{IN(MIN)}) of the PAM3103 is determined by output voltage and dropout voltage. The minimum input voltage is defined as:

$$V_{IN(MIN)} = V_O + V_{DROP}$$

$$V_{IN(MIN)} = 2.5V$$

2. Output current is limited by P_D, maximum I_O = P_D / (V_{IN(MAX)} - V_O).

Typical Performance Characteristics (@ $T_A = +25^\circ\text{C}$, $V_O = 1.2\text{V}$, $C_{IN} = 1\mu\text{F}$, $C_O = 2.2\mu\text{F}$, unless otherwise specified.)

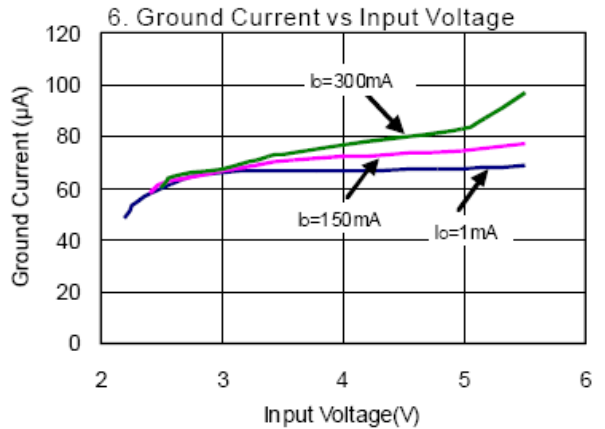
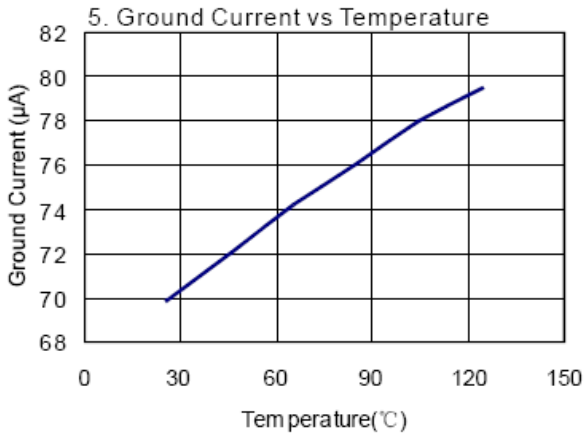
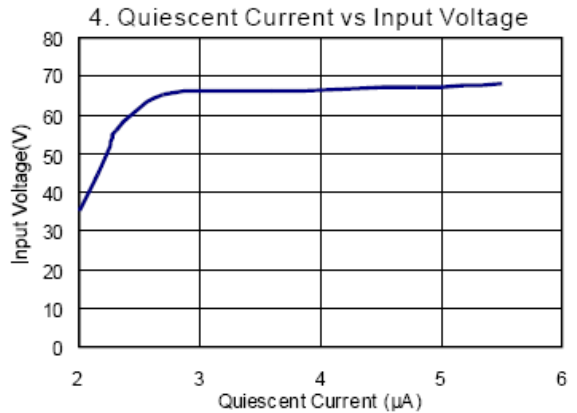
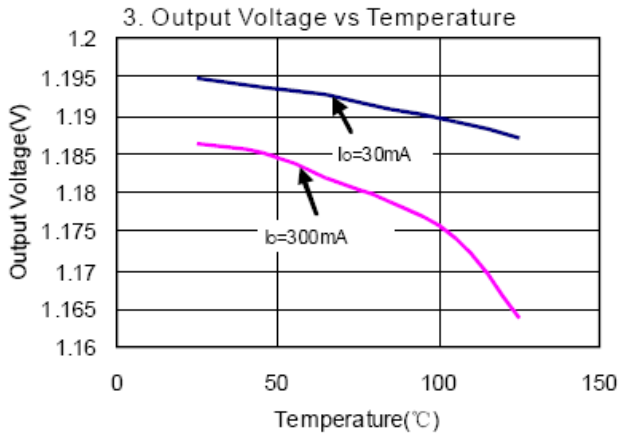
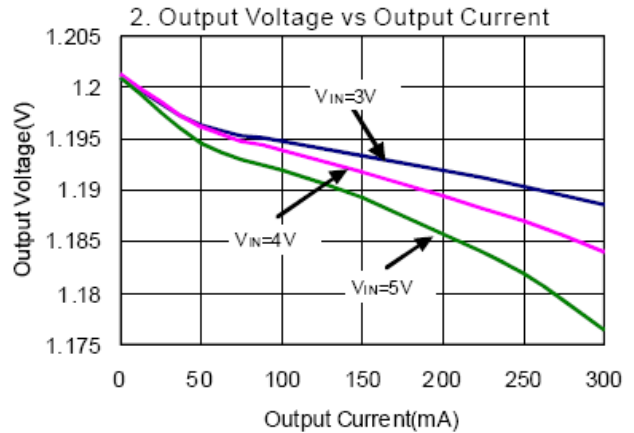
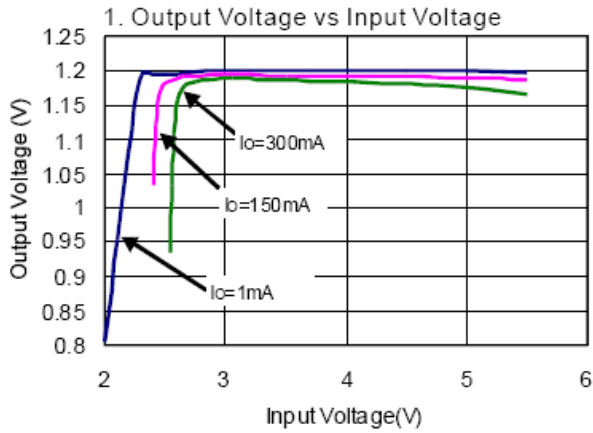

Typical Performance Characteristics (cont.)

7. Load Regulation Transient Response

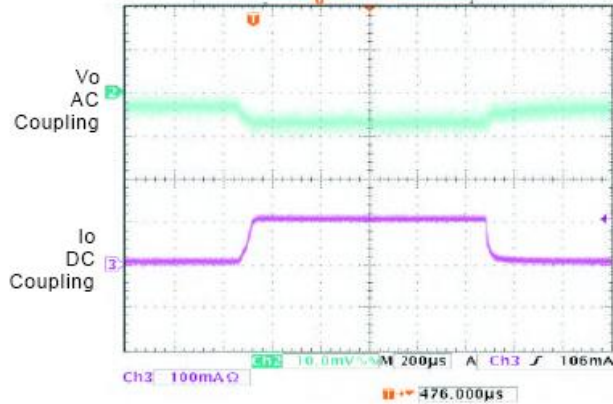

$I_o = 1\text{mA to } 100\text{mA}$

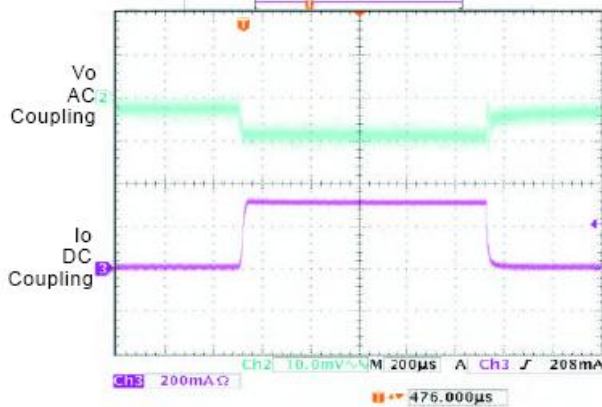

$I_o = 1\text{mA to } 300\text{mA}$

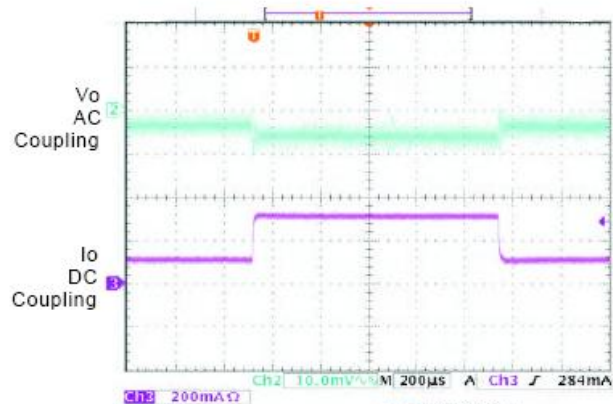

$I_o = 100\text{mA to } 300\text{mA}$

8. Line Regulation Transient Response

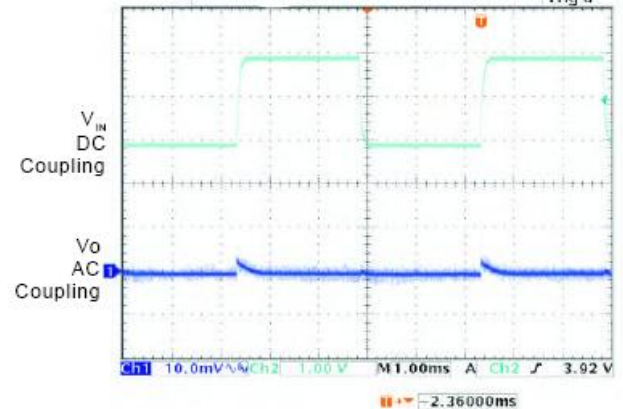

$I_o = 1\text{mA}, V_{IN} = 3\text{V to } 5\text{V}$

9. Power Supply Ripple Rejection

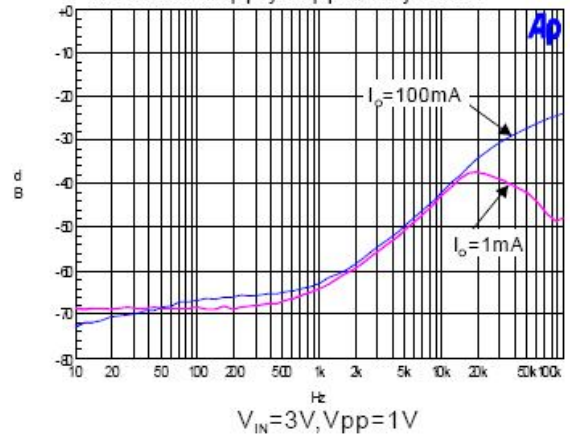

Application Information

Capacitor Selection and Regulator Stability

Similar to any low dropout regulator, the external capacitors used with the PAM3103 must be carefully selected for regulator stability and performance.

A capacitor C_{IN} of more than $1\mu\text{F}$ can be employed in the input pin, while there is no upper limit for the capacitance of C_{IN} . Please note that the distance between C_{IN} and the input pin of the PAM3103 should not exceed 0.5 inch. Ceramic capacitors are suitable for the PAM3103. Capacitors with larger values and lower ESR (equivalent series resistance) provide better PSRR and line-transient response.

The PAM3103 is designed specifically to work with low ESR ceramic output capacitors in order to save space and improve performance. Using an output ceramic capacitor whose value is $> 2.2\mu\text{F}$ with $\text{ESR} > 5\text{m}\Omega$ ensures stability.

ADJ Output Voltage Programming

The output voltage of the PAM3103 adjustable regulator is programmed by using an external resistor divider as shown in Figure 1. The output voltage is calculated as below:

$$V_O = V_{REF}(1 + R1/R2)$$

Resistor R1 and R2 should be chosen for approximately $7\mu\text{A}$ divider current. Lower value resistors can be used but offer no advantage and waste more power. Higher value should be avoided as leakage current at ADJ pin increase the output voltage error. CC is unnecessary when R1 or R2 $< 20\text{k}\Omega$. The recommended design procedure is to choose $R2 = 169\text{k}\Omega$ to set the divider current at $7\mu\text{A}$ and then calculate R1 as below:

$$R1 = (V_O / V_{REF} - 1)R2$$

Load Transient Considerations

Curve 7 of the PAM3103 load-transient response on page 5 shows two components of the output response: a DC shift from the output impedance due to the load current change and transient response. The DC shift is quite small due to excellent load regulation of the PAM3103. The transient spike, resulting from a step change in the load current from 1mA to 300mA , is 20mV . The ESR of the output capacitor is critical to the transient spike. A larger capacitance along with smaller ESR results in a smaller spike.

Shutdown Input Operation

The PAM3103 can be shut down by pulling the EN input low, and turned on by tying the EN input to V_{IN} or leaving the EN input floating.

Internal P-Channel Pass Transistor

The PAM3103 features a 0.75Ω device as a pass transistor. The PMOS pass transistor enables the PAM3103 to consume only $65\mu\text{A}$ of ground current during low dropout, light-load, or heavy-load operation. This feature increases the battery operation life time.

Input-Output (Dropout) Voltage

A regulator's minimum input-output voltage differential (or dropout voltage) determines the lowest usable supply voltage. The PAM3103 has a typical 300mV dropout voltage. In battery powered systems, this will determine the useful end-of-life battery voltage.

Current Limit and Short Circuit Protection

The PAM3103 features a current limit, which monitors and controls the gate voltage of the pass transistor. The output current can be limited to 400mA by regulating the gate voltage. The PAM3103 also has a built-in short circuit current limit.

Application Information (cont.)

Thermal Considerations

Thermal protection limits power dissipation in the PAM3103. When the junction temperature exceeds +150°C, the OTP (Over Temperature Protection) starts the thermal shutdown and turns the pass transistor off. The pass transistor resumes operation after the junction temperature drops below +120°C.

For continuous operation, the junction temperature should be maintained below +125°C. The power dissipation is defined as below:

$$P_D = (V_{IN} - V_{OUT}) * I_O + V_{IN} * I_{GND}$$

The maximum power dissipation depends on the thermal resistance of IC package, PCB layout, the rate of surrounding airflow and temperature difference between junction and ambient. The maximum power dissipation can be calculated by the following formula:

$$P_{D(MAX)} = (T_{J(MAX)} - T_A) / \theta_{JA}$$

Where $T_{J(MAX)}$ is the maximum allowable junction temperature +125°C, T_A is the ambient temperature and θ_{JA} is the thermal resistance from the junction to the ambient.

For example, as θ_{JA} is 250°C/W for the SOT-23 package based on the standard JEDEC 51-3 for a single-layer thermal test board, the maximum power dissipation at $T_A = +25^\circ\text{C}$ can be calculated by following formula:

$$P_{D(MAX)} = (125^\circ\text{C} - 25^\circ\text{C}) / 250 = 0.4\text{W}$$

It is also useful to calculate the junction temperature of the PAM3103 under a set of specific conditions. Suppose the input voltage $V_{IN} = 3.3\text{V}$, the output current $I_O = 300\text{mA}$ and the case temperature $T_A = +40^\circ\text{C}$ measured by a thermal couple during operation, the power dissipation is defined as:

$$P_D = (3.3\text{V} - 2.8\text{V}) * 300\text{mA} + 3.3\text{V} * 70\mu\text{A} \cong 150\text{mW}$$

And the junction temperature T_J can be calculated as follows:

$$T_J = T_A + P_D * \theta_{JA}$$

$$T_J = 40^\circ\text{C} + 0.15\text{W} * 250^\circ\text{C/W}$$

$$= 40^\circ\text{C} + 37.5^\circ\text{C}$$

$$= 77.5^\circ\text{C} < T_{J(MAX)} = +125^\circ\text{C}$$

For this application, T_J is lower than the absolute maximum operating junction temperature +125°C, so it is safe to use the PAM3103 in this configuration.

Ordering Information

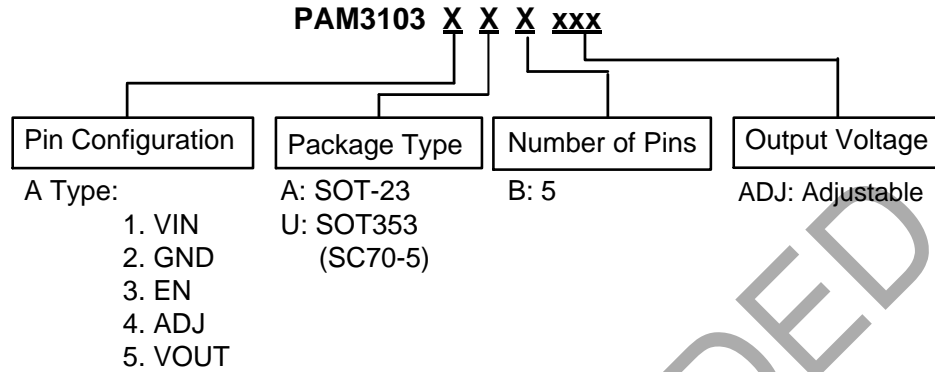

Part Number	Output Voltage	Part Marking	Package Type	Standard Package
PAM3103AABADJ	ADJ	ACAYW	SOT23-5	3000Units/Tape&Reel
PAM3103AUBADJ	ADJ	ACAYW	SOT353(SC70-5)	3000Units/Tape&Reel

Marking Information

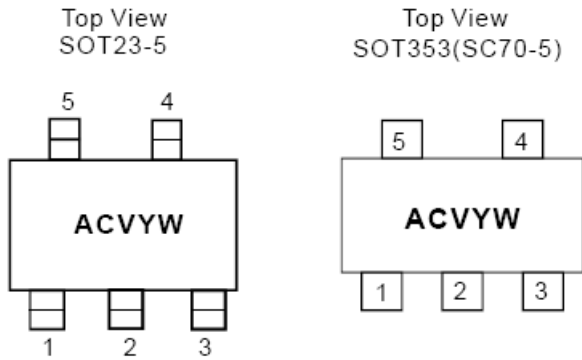

AC: Product Code of PAM3103
 V: Voltage Code
 Y: Year
 W: Week

NOT FOR

Package Outline Dimensions (All dimensions in mm.)

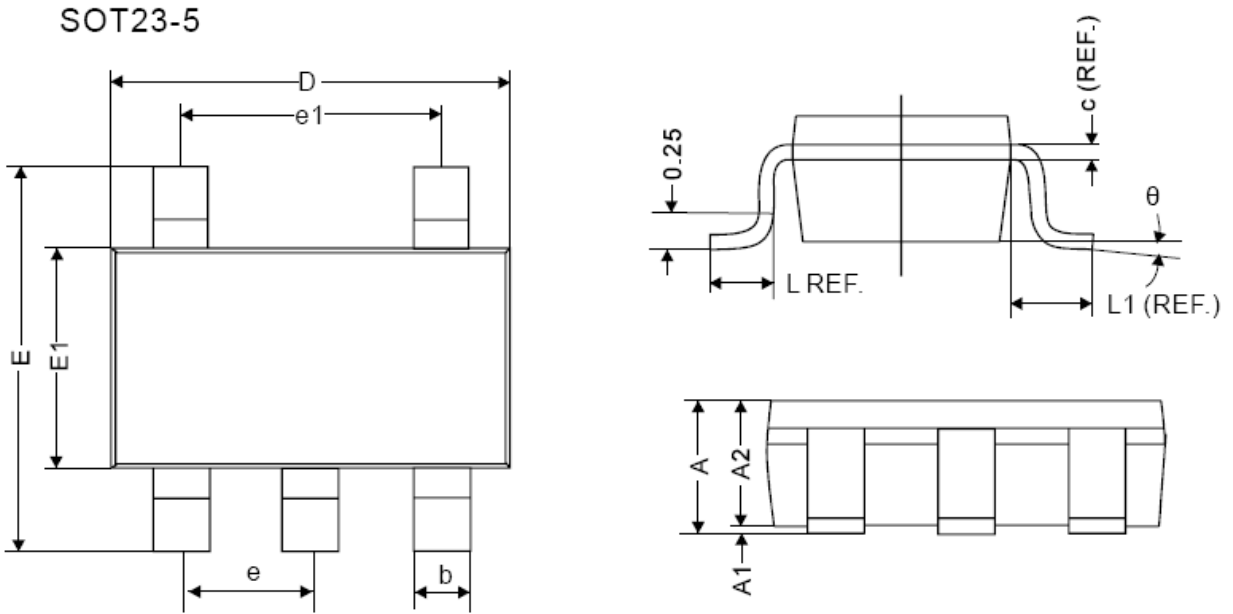

REF.	Millimeter	
	Min	Max
A	1.10 MAX	
A1	0	0.10
A2	0.70	1
c	0.12 REF.	
D	2.70	3.10
E	2.60	3.00
E1	1.40	1.80
L	0.45 REF.	
L1	0.60 REF.	
θ	0°	10°
b	0.30	0.50
e	0.95 REF.	
e1	1.90 REF.	

Package Outline Dimensions (cont.) (All dimensions in mm.)

SOT353(SC70-5)

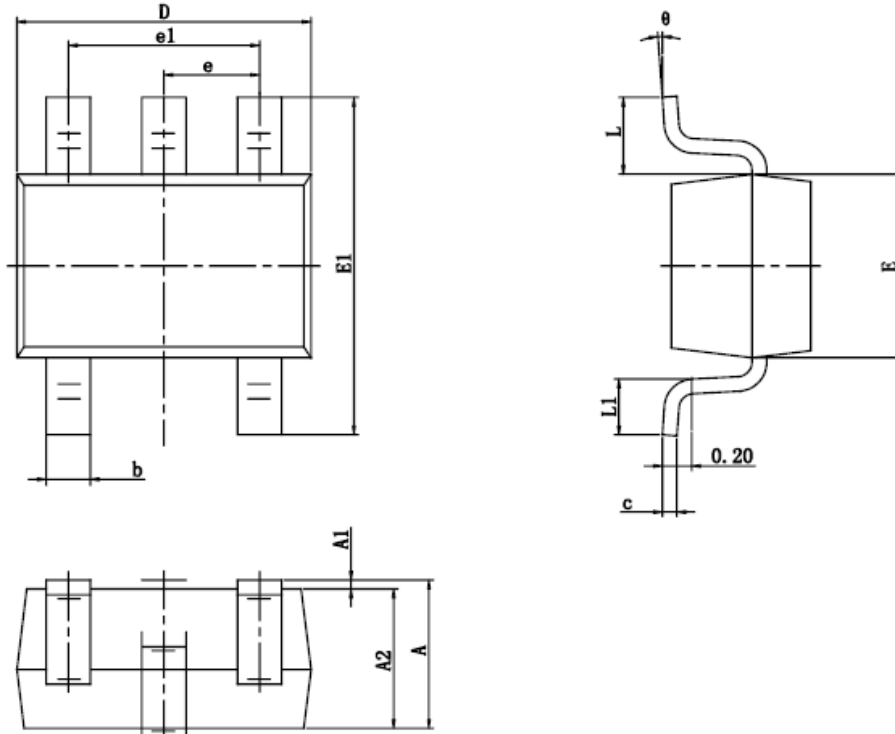

Symbol	Dimensions In Millimeters		Dimensions In Inches	
	Min	Max	Min	Max
A	0.900	1.100	0.035	0.043
A1	0.000	0.100	0.000	0.004
A2	0.900	1.000	0.035	0.039
b	0.150	0.350	0.006	0.014
c	0.080	0.150	0.003	0.006
D	2.000	2.200	0.079	0.087
E	1.150	1.350	0.045	0.053
E1	2.150	2.450	0.085	0.096
e	0.650 TYP		0.026 TYP	
e1	1.200	1.400	0.047	0.055
L	0.525 REF		0.021 REF	
L1	0.260	0.460	0.010	0.018
θ	0	8	0	8

IMPORTANT NOTICE

DIODES INCORPORATED MAKES NO WARRANTY OF ANY KIND, EXPRESS OR IMPLIED, WITH REGARDS TO THIS DOCUMENT, INCLUDING, BUT NOT LIMITED TO, THE IMPLIED WARRANTIES OF MERCHANTABILITY AND FITNESS FOR A PARTICULAR PURPOSE (AND THEIR EQUIVALENTS UNDER THE LAWS OF ANY JURISDICTION).

Diodes Incorporated and its subsidiaries reserve the right to make modifications, enhancements, improvements, corrections or other changes without further notice to this document and any product described herein. Diodes Incorporated does not assume any liability arising out of the application or use of this document or any product described herein; neither does Diodes Incorporated convey any license under its patent or trademark rights, nor the rights of others. Any Customer or user of this document or products described herein in such applications shall assume all risks of such use and will agree to hold Diodes Incorporated and all the companies whose products are represented on Diodes Incorporated website, harmless against all damages.

Diodes Incorporated does not warrant or accept any liability whatsoever in respect of any products purchased through unauthorized sales channel. Should Customers purchase or use Diodes Incorporated products for any unintended or unauthorized application, Customers shall indemnify and hold Diodes Incorporated and its representatives harmless against all claims, damages, expenses, and attorney fees arising out of, directly or indirectly, any claim of personal injury or death associated with such unintended or unauthorized application.

Products described herein may be covered by one or more United States, international or foreign patents pending. Product names and markings noted herein may also be covered by one or more United States, international or foreign trademarks.

This document is written in English but may be translated into multiple languages for reference. Only the English version of this document is the final and determinative format released by Diodes Incorporated.

LIFE SUPPORT

Diodes Incorporated products are specifically not authorized for use as critical components in life support devices or systems without the express written approval of the Chief Executive Officer of Diodes Incorporated. As used herein:

A. Life support devices or systems are devices or systems which:

1. are intended to implant into the body, or
2. support or sustain life and whose failure to perform when properly used in accordance with instructions for use provided in the labeling can be reasonably expected to result in significant injury to the user.

B. A critical component is any component in a life support device or system whose failure to perform can be reasonably expected to cause the failure of the life support device or to affect its safety or effectiveness.



Customers represent that they have all necessary expertise in the safety and regulatory ramifications of their life support devices or systems, and acknowledge and agree that they are solely responsible for all legal, regulatory and safety-related requirements concerning their products and any use of Diodes Incorporated products in such safety-critical, life support devices or systems, notwithstanding any devices- or systems-related information or support that may be provided by Diodes Incorporated. Further, Customers must fully indemnify Diodes Incorporated and its representatives against any damages arising out of the use of Diodes Incorporated products in such safety-critical, life support devices or systems.

Copyright © 2016, Diodes Incorporated

www.diodes.com

Looking for pricing, stock, or lifecycle information?

Click below to explore more details on WIN SOURCE:

-  [View PAM3103AABADJ on WIN SOURCE](#)
-  [Diodes Incorporated Information](#)

Optimize Your Supply Chain with WIN SOURCE Solutions

-  Global Sourcing Solution
-  Obsolete Management
-  Cost Control Management
-  Shortage Management
-  Alternative Solution
-  Excess Inventory Management