



**THE DATASHEET OF  
PAM3110ABA150R**



## Description

The PAM3110 is a 1.5A CMOS LDO regulator that features a low quiescent current and low dropout voltages, as well as over temperature shutdown. The fixed output voltage of the PAM3110 is set at the factory and trimmed to  $\pm 1.5\%$ . The PAM3110 is stable with a ceramic output capacitor of 4.7 $\mu$ F or higher.

This family of regulators can provide either a stand-alone power supply solution or act as a post regulator for switch mode power supplies. They are particularly suitable for applications requiring low input and output voltages.

PAM3110 is available in SOT-223, TO-252 and TO-263-2L package.

## Features

- DSP, FPGA and Microprocessor Power Supplies
- Output Voltages: 1.2V, 1.5V, 1.8V, 2.5V 3.3V and 5.0V
- Stable with a Ceramic Output Capacitor
- Dropout Voltage: 400mV @ 1.5A
- Low Quiescent Current
- Over Temperature Shutdown
- Short Circuit Protection
- Low Temperature Coefficient
- Pb-Free Packages

## Applications

- DSP, FPGA and Microprocessor Power Supplies
- SATA Power Supply
- LCD TV/Monitors
- Wireless Devices
- Communication Devices
- Portable Electronics
- Post Regulator for SMS

## Pin Assignments

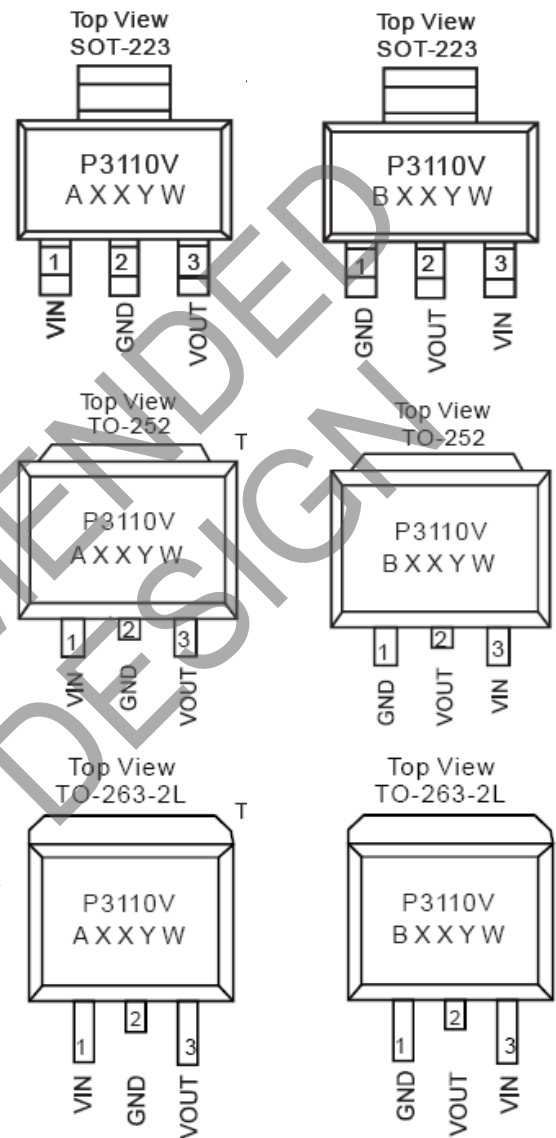

**Typical Applications Circuit**

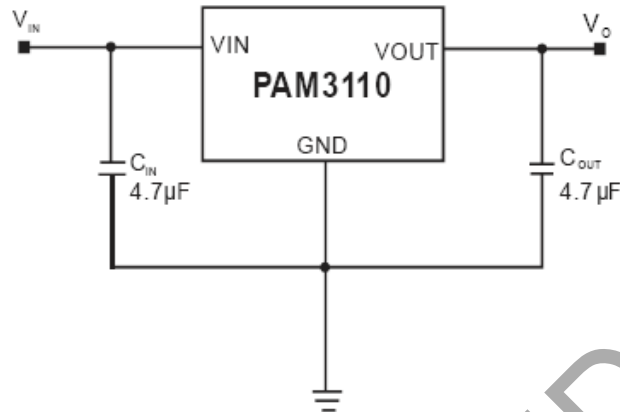

**Pin Configuration and Description**

Pin Name	Pin Number		Function
	SOP-8(EP)	W-DFN3x3-10	
VIN	3	7, 8, 9	Supply Input Voltage.
EN	2	6	Chip Enable (Active-High).
CTRL	4	10	Supply Voltage of Control Circuitry.
POK	1	5	Power Good Open Drain Output.
ADJ	7	4	Set the output voltage by the feedback resistors. $V_O = 0.8V \times (R1 + R2)/R2$ .
VOUT	6	1, 2, 3	Output Voltage.
NC	5	—	No Internal Connection.
GND	8, Exposed Pad (9)	Exposed Pad (11)	Ground. The exposed pad must be soldered to a large PCB and connected to GND for maximum power dissipation.

**Functional Block Diagram**

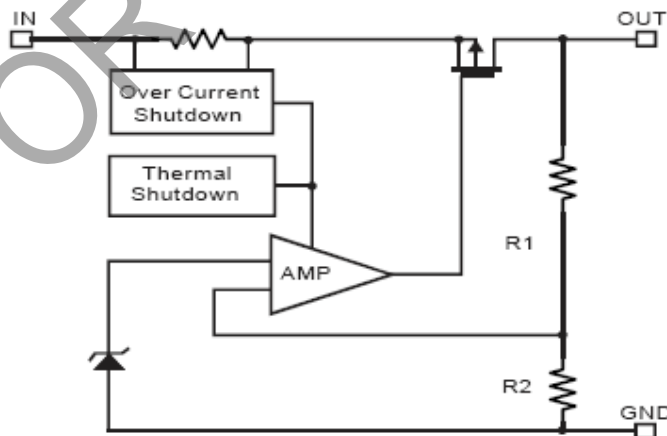

**Absolute Maximum Ratings** (@T<sub>A</sub> = +25°C, unless otherwise specified.)

These are stress ratings only and functional operation is not implied. Exposure to absolute maximum ratings for prolonged time periods may affect device reliability. All voltages are with respect to ground.

Parameter	Rating	Unit
Input Voltage	6	V
Storage Temperature	-65 to +150	°C
Maximum Junction Temperature	150	°C
Lead Soldering Temperature	300, (5sec)	°C

**Recommended Operating Conditions** (@T<sub>A</sub> = +25°C, unless otherwise specified.)

Parameter	Rating	Unit
Supply Voltage	2.5 to 5.5	V
Ambient Temperature Range	-40 to +85	°C
Junction Temperature Range	-40 to +125	

**Thermal Information**

Parameter	Symbol	Package	Max	Unit
Thermal Resistance Junction to Case)	$\theta_{JC}$	SOT-223	7	°C/W
		TO-252	7	
		TO-263	7	
Thermal Resistance (Junction to Ambient)	$\theta_{JA}$	SOT-223	160	
		TO-252	90	
		TO-263	60	
Internal Power Dissipation (@T <sub>A</sub> = 25°C)	P <sub>D</sub>	SOT-223	625	mW
		TO-252	1200	
		TO-263	2000	

NOT RECOMMENDED FOR NEW DESIGN

**Electrical Characteristics** (@ $T_A = +25^\circ\text{C}$ ,  $V_{IN} = V_O + 0.5\text{V}$ ,  $V_{CTRL} = V_{EN} = 5\text{V}$ ,  $C_{IN} = C_O = 10\mu\text{F}$ , unless otherwise specified.)

Parameter	Symbol	Test Conditions		Min	Typ	Max	Units
Input Voltage Range	$V_{IN}$			2.5		5.5	V
Output Voltage Accuracy	$V_O$	$I_O = 1\text{mA to } 1.5\text{A}$		-1.5		1.5	%
Dropout Voltage	$V_{DROP}$	$I_O = 500\text{mA}$	$V_O \geq 2.5\text{V}$		200		mV
		$I_O = 1.5\text{A}$	$V_O \geq 2.5\text{V}$		400		
Short Circuit Current	$I_{SC}$	$V_O < 0.3\text{V}$			500		mA
Quiescent Current	$I_Q$	$I_O = 0\text{mA}$			75	150	$\mu\text{A}$
Current Limit	$I_{LIM}$				2		A
Line Regulation	LNR	$V_O \leq 2.5\text{V}$ , $I_O = 10\text{mA}$ $V_{IN} = V_O + 1.5\text{V to } V_O + 2.5\text{V}$			0.5	1	%V
		$V_O > 2.5\text{V}$ , $I_O = 10\text{mA}$ $V_{IN} = V_O + 0.5\text{V to } V_O + 1.5\text{V}$					
Load Regulation	LDR	$I_O = 1\text{mA to } 100\text{A}$			0.5	1	%
Over Temperature Shutdown	OTS				160		$^\circ\text{C}$
Over Temperature Hysteresis	OTH				30		$^\circ\text{C}$
Temperature Coefficient	$T_C$				40		ppm/ $^\circ\text{C}$
Power Supply Ripple Rejection	PSRR	$I_O = 100\text{mA}$	$f = 100\text{Hz}$		55		dB
			$f = 1\text{kHz}$		50		
			$f = 10\text{kHz}$		35		

NOT RECOMMENDED FOR NEW DESIGN

**Typical Performance Characteristics** (@ $T_A = +25^\circ\text{C}$ ,  $C_{IN} = 4.7\mu\text{F}$ ,  $C_{OUT} = 4.7\mu\text{F}$ , unless otherwise specified.)

1. Output Voltage vs Input Voltage

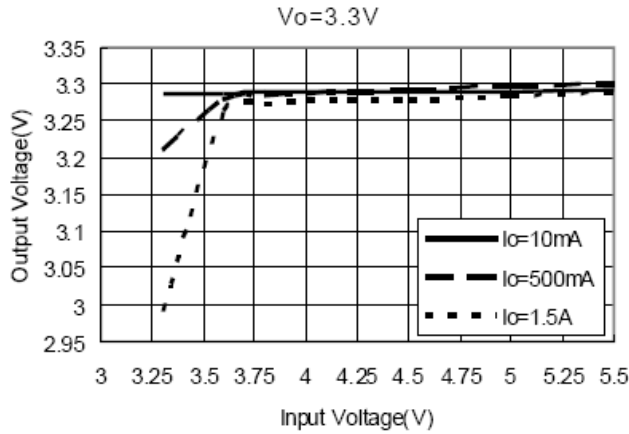

2. Output Voltage vs Output Current

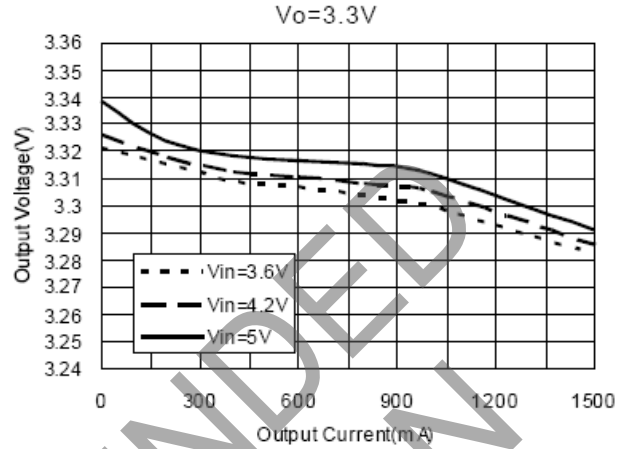

3. Quiescent Current vs Input Voltage

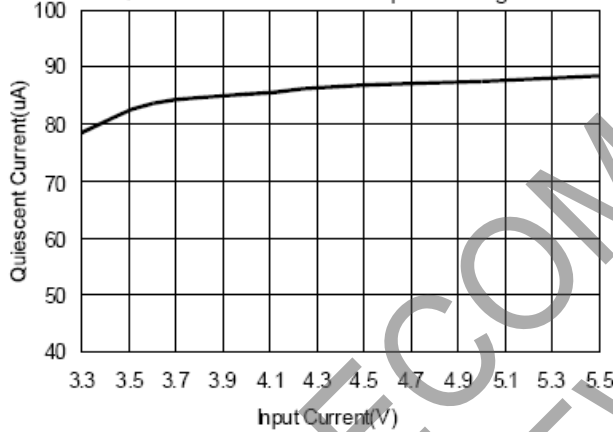

4. Quiescent Current vs Temperature

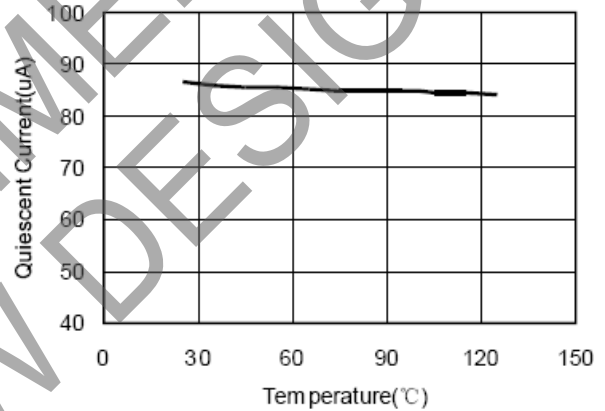

5. Maximum Output Current vs Input Voltage

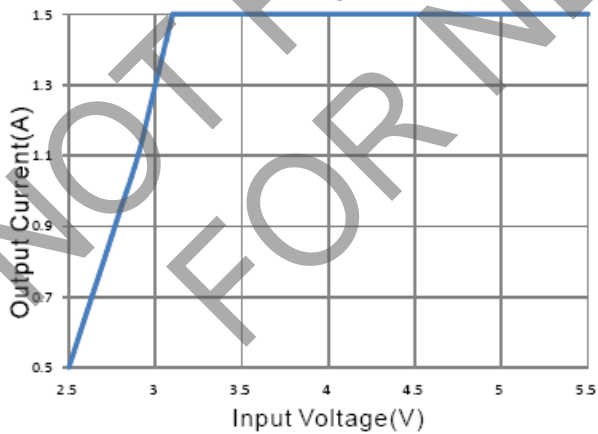

**Typical Performance Characteristics** (cont.) (@ $T_A = +25^\circ\text{C}$ ,  $C_{IN} = 4.7\mu\text{F}$ ,  $C_{OUT} = 4.7\mu\text{F}$ , unless otherwise specified.)

6. Safety Operation Area

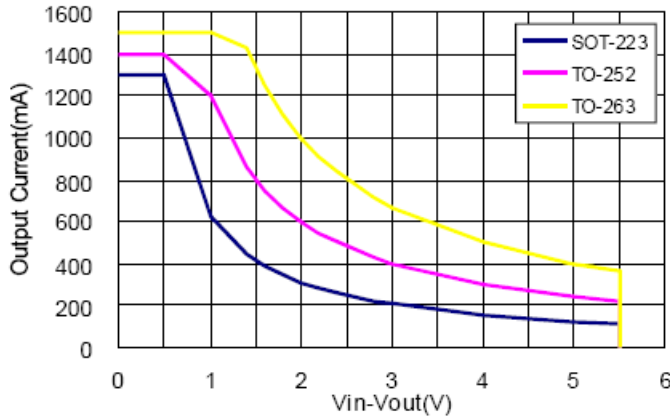

7. Ripple Rejection vs Frequency

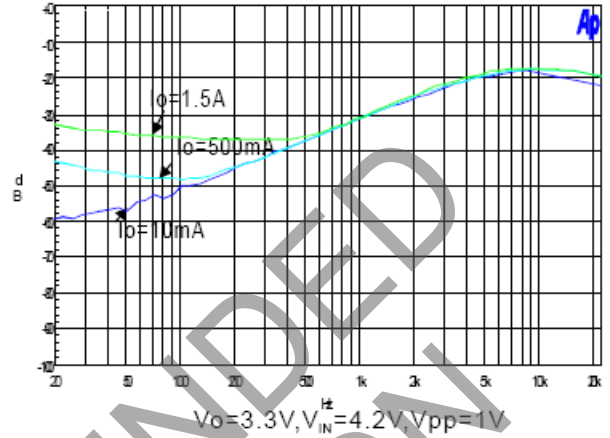

8. Load Transient Response

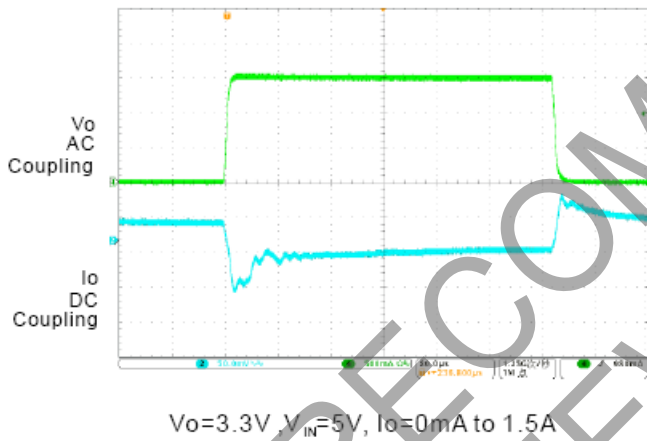

9. Line Transient Response

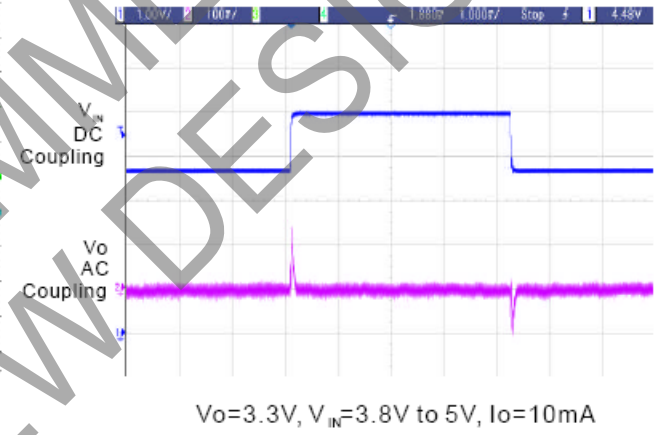

NOT RECOMMENDED FOR NEW DESIGN

## Application Information

The PAM3110 family of low-dropout (LDO) regulators have several features that allow them to apply to a wide range of applications. The family operates with very low input voltage and low dropout voltage (typically 300mV at full load), making it an efficient stand-alone power supply or post regulator for battery or switch mode power supplies. The 1.5A output current make the PAM3110 family suitable for powering many microprocessors and FPGA supplies.

### External Capacitor Requirements

A 4.7µF or larger ceramic input bypass capacitor, connected between  $V_{IN}$  and GND and located close to the PAM3110, is required for stability. A 4.7µF minimum value capacitor from  $V_O$  to GND is also required. To improve transient response, noise rejection, and ripple rejection, an additional 10µF or larger, low ESR capacitor is recommended at the output. A higher-value, low ESR output capacitor may be necessary if large, fast-rise-time load transients are anticipated and the device is located several inches from the power source, especially if the minimum input voltage of 2.5V is used.

### Regulator Protection

The PAM3110 features internal current limiting, thermal protection and short circuit protection. During normal operation, the PAM3110 limits output current to about 2A. When current limiting engages, the output voltage scales back linearly until the over current condition ends. While current limiting is designed to prevent gross device failure, care should be taken not to exceed the power dissipation ratings of the package. If the temperature of the device exceeds +150°C, thermal-protection circuitry will shut down. Once the device has cooled down to approximately +30°C below the high temp trip point, regulator operation resumes. The short circuit current of the PAM3110 is about 0.5A when its output pin is shorted to ground.

### Thermal Information

The amount of heat that an LDO linear regulator generates is:

$$P_D = (V_{IN} - V_O)I_O$$

All integrated circuits have a maximum allowable junction temperature ( $T_{J(MAX)}$ ) above which normal operation is not assured. A system designer must design the operating environment so that the operating junction temperature ( $T_{J(MAX)}$ ) does not exceed the maximum junction temperature ( $T_{J(MAX)}$ ). The two main environmental variables that a designer can use to improve thermal performance are air flow and external heat sinks. The purpose of this information is to aid the designer in determining the proper operating environment for a linear regulator that is operating at a specific power level.

In general, the maximum expected power ( $P_{D(MAX)}$ ) consumed by a linear regulator is computed as:

Where:

- $V_{I(AVG)}$  is the average input voltage.
- $V_{O(AVG)}$  is the average output voltage.
- $I_{O(AVG)}$  is the average output current.
- $I_{(Q)}$  is the quiescent current.

For most LDO regulators, the quiescent current is insignificant compared to the average output current; therefore, the term  $V_{I(AVG)} \times I_{(Q)}$  can be neglected. The operating junction temperature is computed by adding the ambient temperature ( $T_A$ ) and the increase in temperature due to the regulator's power dissipation. The temperature rise is computed by multiplying the maximum expected power dissipation by the sum of the thermal resistances between the junction and the case ( $R_{\theta JC}$ ), the case to heatsink ( $R_{\theta CS}$ ), and the heatsink to ambient ( $R_{\theta SA}$ ). Thermal resistances are measures of how effectively an object dissipates heat. Typically, the larger the device, the more surface area available for power dissipation so that the object's thermal resistance will be lower.

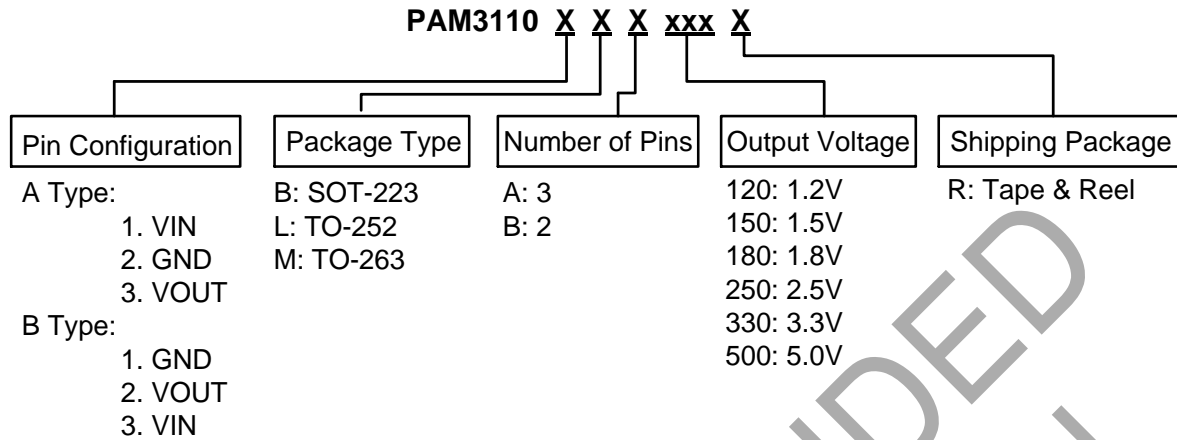
**Ordering Information**

Part Number	Output Voltage	Marking	Package Type	Standard Package
PAM3110ABA120R	1.2V	P3110B AXXYW	SOT-223	2500 Units/Tape&Reel
PAM3110BBA120R	1.2V	P3110B BXXYW	SOT-223	2500 Units/Tape&Reel
PAM3110ALA120R	1.2V	P3110B BXXYW	TO-252	2500 Units/Tape&Reel
PAM3110BLA120R	1.2V	P3110B BXXYW	TO-252	2500 Units/Tape&Reel
PAM3110AMB120R	1.2V	P3110B BXXYW	TO-263-2L	800 Units/Tape&Reel
PAM3110BMB120R	1.2V	P3110B BXXYW	TO-263-2L	800 Units/Tape&Reel
PAM3110ABA150R	1.5V	P3110C AXXYW	SOT-223	2500 Units/Tape&Reel
PAM3110BBA150R	1.5V	P3110C BXXYW	SOT-223	2500 Units/Tape&Reel
PAM3110ALA150R	1.5V	P3110C AXXYW	TO-252	2500 Units/Tape&Reel
PAM3110BLA150R	1.5V	P3110C BXXYW	TO-252	2500 Units/Tape&Reel
PAM3110AMB150R	1.5V	P3110C AXXYW	TO-263-2L	800 Units/Tape&Reel
PAM3110BMB150R	1.5V	P3110C BXXYW	TO-263-2L	800 Units/Tape&Reel
PAM3110ABA180R	1.8V	P3110E AXXYW	SOT-223	2500 Units/Tape&Reel
PAM3110BBA180R	1.8V	P3110E BXXYW	SOT-223	2500 Units/Tape&Reel
PAM3110ALA180R	1.8V	P3110E AXXYW	TO-252	2500 Units/Tape&Reel
PAM3110BLA180R	1.8V	P3110E BXXYW	TO-252	2500 Units/Tape&Reel
PAM3110AMB180R	1.8V	P3110E AXXYW	TO-263-2L	800 Units/Tape&Reel
PAM3110BMB180R	1.8V	P3110E BXXYW	TO-263-2L	800 Units/Tape&Reel

**Ordering Information** (cont.)

Part Number	Output Voltage	Marking	Package Type	Standard Package
PAM3110ABA250R	2.5V	P3110G AXXYW	SOT-223	2500 Units/Tape&Reel
PAM3110BBA250R	2.5V	P3110G BXXYW	SOT-223	2500 Units/Tape&Reel
PAM3110ALA250R	2.5V	P3110G AXXYW	TO-252	2500 Units/Tape&Reel
PAM3110BLA250R	2.5V	P3110G BXXYW	TO-252	2500 Units/Tape&Reel
PAM3110AMB250R	2.5V	P3110G AXXYW	TO-263-2L	800 Units/Tape&Reel
PAM3110BMB250R	2.5V	P3110G BXXYW	TO-263-2L	800 Units/Tape&Reel
PAM3110ABR330R	3.3V	P3110K AXXYW	SOT-223	2500 Units/Tape&Reel
PAM3110BBA330R	3.3V	P3110K BXXYW	SOT-223	2500 Units/Tape&Reel
PAM3110ALA330R	3.3V	P3110K AXXYW	TO-252	2500 Units/Tape&Reel
PAM3110BLA330R	3.3V	P3110K BXXYW	TO-252	2500 Units/Tape&Reel
PAM3110AMB330R	3.3V	P3110K AXXYW	TO-263-2L	800 Units/Tape&Reel
PAM3110BMB330R	3.3V	P3110K BXXYW	TO-263-2L	800 Units/Tape&Reel
PAM3110ABA500R	5.0V	P3110L AXXYW	SOT-223	2500 Units/Tape&Reel
PAM3110BBA500R	5.0V	P3110L BXXYW	SOT-223	2500 Units/Tape&Reel
PAM3110ALA500R	5.0V	P3110L AXXYW	TO-252	2500 Units/Tape&Reel
PAM3110BLA500R	5.0V	P3110L BXXYW	TO-252	2500 Units/Tape&Reel
PAM3110AMB500R	5.0V	P3110L AXXYW	TO-263-2L	800 Units/Tape&Reel
PAM3110BMB500R	5.0V	P3110L BXXYW	TO-263-2L	800 Units/Tape&Reel

NOT RECOMMENDED FOR NEW DESIGN

**Marking Information**

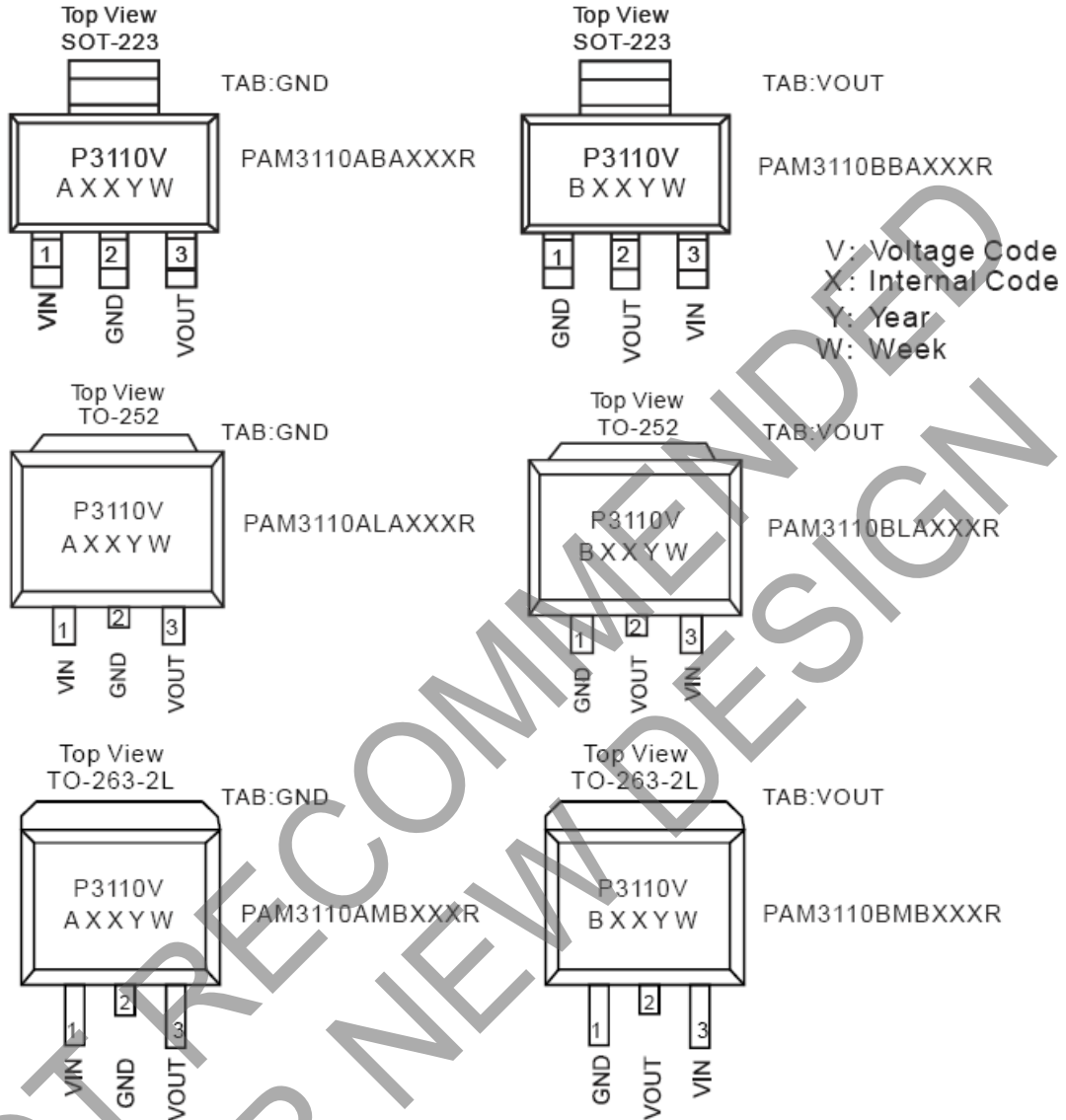

NOT RECOMMENDED FOR NEW DESIGN

**Package Outline Dimensions** (All dimensions in mm.)

SOT-223

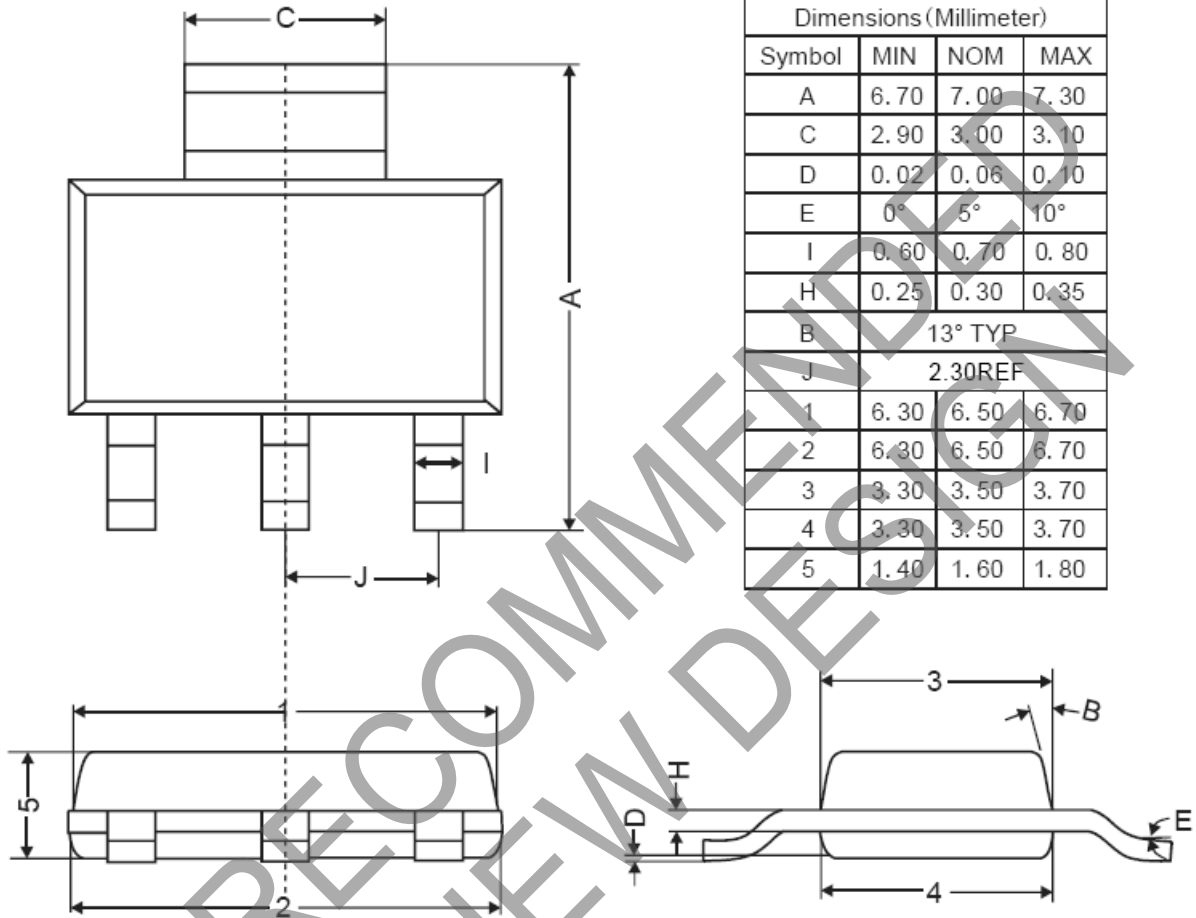

NOT RECOMMENDED FOR NEW DESIGN

**Package Outline Dimensions** (cont.) (All dimensions in mm.)

TO-252

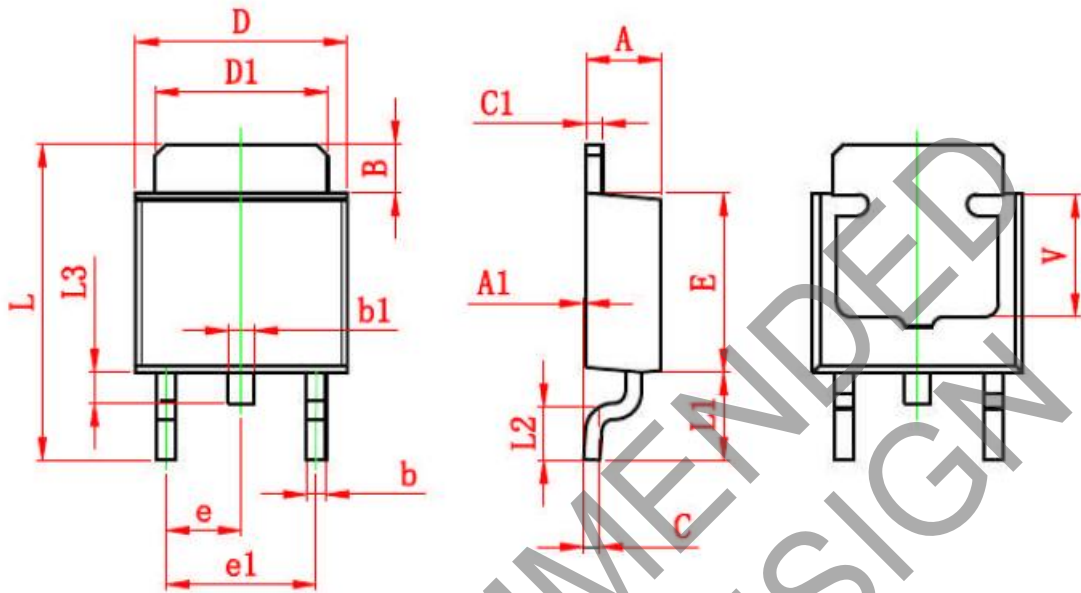

Symbol	Dimensions in Millimeters		Dimensions in Inches	
	Min.	Max.	Min.	Max.
A	2.200	2.400	0.087	0.094
A1	0.000	0.127	0.000	0.005
B	1.350	1.650	0.053	0.065
b	0.500	0.700	0.020	0.028
b1	0.700	0.900	0.028	0.035
c	0.430	0.580	0.017	0.023
c1	0.430	0.580	0.017	0.023
D	6.350	6.650	0.250	0.262
D1	5.200	5.400	0.205	0.213
E	5.400	5.700	0.213	0.224
e	2.300 TYP.		0.091 TYP.	
e1	4.500	4.700	0.177	0.185
L	9.500	9.900	0.374	0.390
L1	2.550	2.900	0.100	0.114
L2	1.400	1.780	0.055	0.070
L3	0.600	0.900	0.024	0.035
V	3.800 REF.		0.150 REF.	

#### IMPORTANT NOTICE

DIODES INCORPORATED MAKES NO WARRANTY OF ANY KIND, EXPRESS OR IMPLIED, WITH REGARDS TO THIS DOCUMENT, INCLUDING, BUT NOT LIMITED TO, THE IMPLIED WARRANTIES OF MERCHANTABILITY AND FITNESS FOR A PARTICULAR PURPOSE (AND THEIR EQUIVALENTS UNDER THE LAWS OF ANY JURISDICTION).

Diodes Incorporated and its subsidiaries reserve the right to make modifications, enhancements, improvements, corrections or other changes without further notice to this document and any product described herein. Diodes Incorporated does not assume any liability arising out of the application or use of this document or any product described herein; neither does Diodes Incorporated convey any license under its patent or trademark rights, nor the rights of others. Any Customer or user of this document or products described herein in such applications shall assume all risks of such use and will agree to hold Diodes Incorporated and all the companies whose products are represented on Diodes Incorporated website, harmless against all damages.

Diodes Incorporated does not warrant or accept any liability whatsoever in respect of any products purchased through unauthorized sales channel. Should Customers purchase or use Diodes Incorporated products for any unintended or unauthorized application, Customers shall indemnify and hold Diodes Incorporated and its representatives harmless against all claims, damages, expenses, and attorney fees arising out of, directly or indirectly, any claim of personal injury or death associated with such unintended or unauthorized application.

Products described herein may be covered by one or more United States, international or foreign patents pending. Product names and markings noted herein may also be covered by one or more United States, international or foreign trademarks.

This document is written in English but may be translated into multiple languages for reference. Only the English version of this document is the final and determinative format released by Diodes Incorporated.

#### LIFE SUPPORT

Diodes Incorporated products are specifically not authorized for use as critical components in life support devices or systems without the express written approval of the Chief Executive Officer of Diodes Incorporated. As used herein:

A. Life support devices or systems are devices or systems which:

1. are intended to implant into the body, or
2. support or sustain life and whose failure to perform when properly used in accordance with instructions for use provided in the labeling can be reasonably expected to result in significant injury to the user.

B. A critical component is any component in a life support device or system whose failure to perform can be reasonably expected to cause the failure of the life support device or to affect its safety or effectiveness.

Customers represent that they have all necessary expertise in the safety and regulatory ramifications of their life support devices or systems, and acknowledge and agree that they are solely responsible for all legal, regulatory and safety-related requirements concerning their products and any use of Diodes Incorporated products in such safety-critical, life support devices or systems, notwithstanding any devices- or systems-related information or support that may be provided by Diodes Incorporated. Further, Customers must fully indemnify Diodes Incorporated and its representatives against any damages arising out of the use of Diodes Incorporated products in such safety-critical, life support devices or systems.

Copyright © 2017, Diodes Incorporated

[www.diodes.com](http://www.diodes.com)

## Looking for pricing, stock, or lifecycle information?

Click below to explore more details on WIN SOURCE:

- ⊖ [View PAM3110ABA150R on WIN SOURCE](#)
- ⊖ [Diodes Incorporated Information](#)

## Optimize Your Supply Chain with WIN SOURCE Solutions

- ✓ Global Sourcing Solution
- ✓ Obsolete Management
- ✓ Cost Control Management
- ✓ Shortage Management
- ✓ Alternative Solution
- ✓ Excess Inventory Management