



**THE DATASHEET OF
PAM3112DAB120**



Description

The PAM3112 regulator features low quiescent current (65µA Typ) and excellent line/load regulation, making it ideal for battery powered applications. The output voltage can be 1.2V or 1.3V. Space-saving packages SOT23, TSOT25, SOT-89 and SC70 are attractive for portable and handheld applications. It has both thermal shutdown and a current limit features to prevent device failure under extreme operating conditions. The device is stable with an output capacitance of 2.2µF or greater.

Features

- Accuracy within ±2%
- Quiescent Current: 65µA Typ.
- Excellent Line/Load Regulation
- Guaranteed 300mA Output Current
- Fast Response
- Current Limiting
- Short Circuit Protection
- Low Temperature Coefficient
- Thermal Shutdown
- Space Saving Package: SOT23, TSOT25, SOT-89 and SC70
- Pb-Free Package

Applications

- Cordless Phone
- Cellular Phone
- Bluetooth Earphone
- Digital Camera
- Portable Electronics
- WLAN
- MP3 Player

Pin Assignments

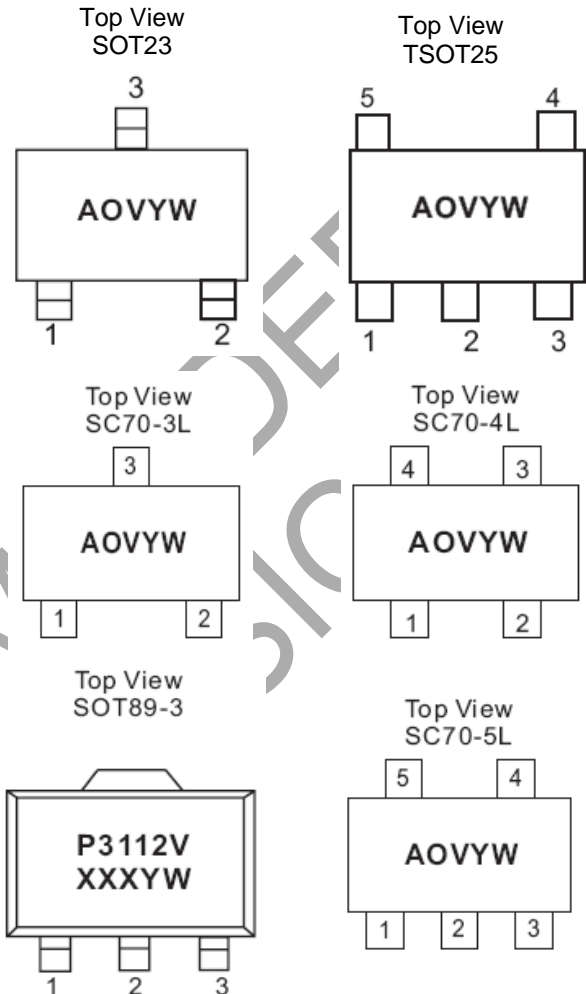

Typical Applications Circuit

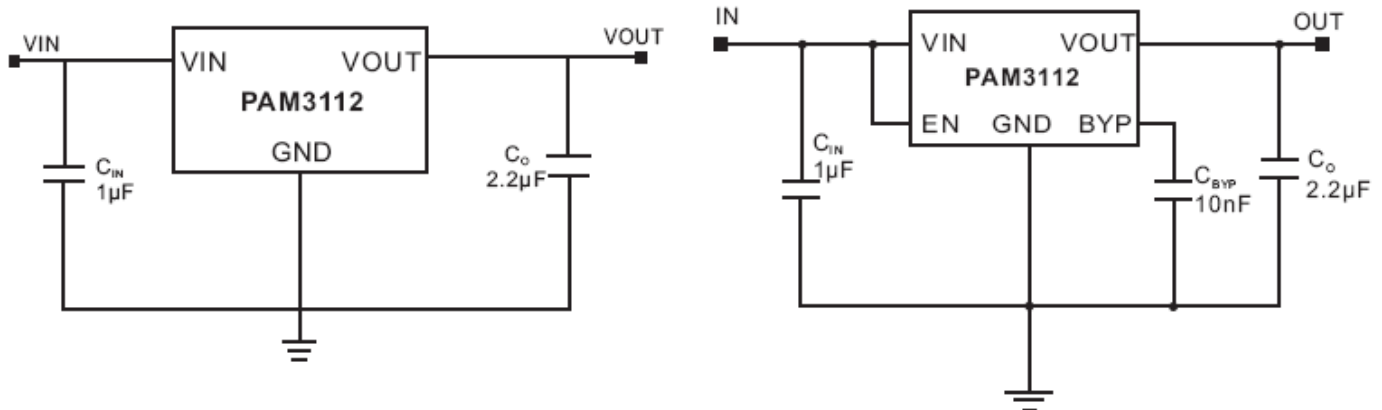

Pin Configuration and Description

Package Type	Pin Number				
	1	2	3	4	5
SOT23	VOUT	GND	VIN	—	—
	GND	VOUT	VIN	—	—
TSOT25	VIN	GND	EN	BYP	VOUT
SOT89-3	GND	VIN	VOUT	—	—
	VOUT	GND	VIN	—	—
SC70-3L	VIN	VOUT	GND	—	—
SC70-4L	EN	GND	VOUT	VIN	—
SC70-5L	VIN	GND	EN	BYP	VOUT

Pin Name	Function
VIN	Input
GND	Ground
EN	Chip Enable (active high)
BYP	Bypass Pin, need a 10nF capacitor connect to GND
VOUT	Output

Functional Block Diagram

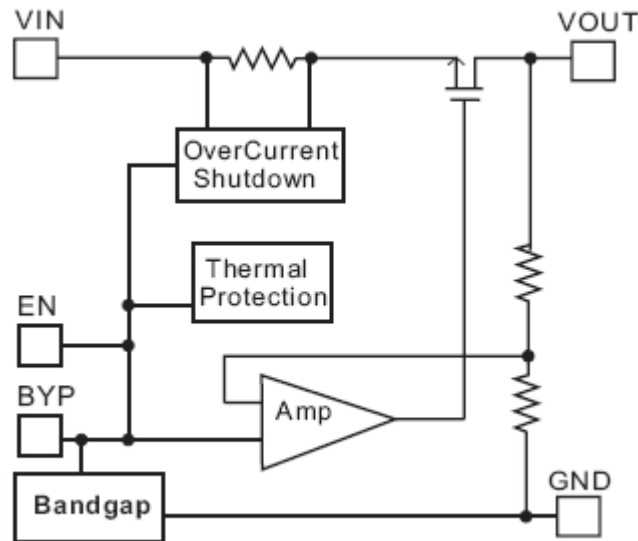

Absolute Maximum Ratings (@T_A = +25°C, unless otherwise specified.)

These are stress ratings only and functional operation is not implied. Exposure to absolute maximum ratings for prolonged time periods may affect device reliability. All voltages are with respect to ground.

Parameter	Rating	Unit
Input Voltage	6.0	V
Output Current	P _D /(V _{IN} - V _O)	—
Output Pin Voltage	GND -0.3 to V _{IN} +0.3V	V
Lead Soldering Temperature	300, (5sec)	°C
Maximum Junction Temperature	150	°C
Storage Temperature	-65 to +150	°C
ESD Rating	Class B	—

Recommended Operating Conditions (@T_A = +25°C, unless otherwise specified.)

Parameter	Rating	Unit
Junction Temperature	-40 to +125	°C
Ambient Temperature	-40 to +85	

Thermal Information

Parameter	Symbol	Package	Max	Unit
Thermal Resistance (Junction to Case)	θ_{JC}	SOT23/ TSOT25	130	°C/W
		SOT-89	45	
		SC70	TBD	
Thermal Resistance (Junction to Ambient)	θ_{JA}	SOT23/ TSOT25	250	
		SOT-89	160	
		SC70	300	
Internal Power Dissipation (@T _A = +25°C)	P _D	SOT23/ TSOT25	400	mW
		SOT-89	550	
		SC70	300	

Electrical Characteristics (@ $T_A = +25^\circ\text{C}$, $V_{IN} = 3\text{V}$, $C_{IN} = 1\mu\text{F}$, $C_O = 2.2\mu\text{F}$, unless otherwise specified.)

Parameter	Symbol	Test Conditions	Min	Typ	Max	Units	
Input Voltage	V_{IN}	—	2.5	—	5.5	V	
Output Voltage Accuracy	V_O	$I_O = 1\text{mA}$	-2	—	+2	%	
Output Current	I_O	—	300	—	Note 1	mA	
Ground Current	I_{GND}	$I_O = 1\text{mA}$ to 300mA	—	70	90	μA	
Quiescent Current	I_Q	$I_O = 0\text{mA}$	—	65	90	μA	
Line Regulation	LNR	$V_{IN} = 2.5\text{V}$ to 5.0V $I_O = 10\text{mA}$	-0.15	0.10	0.15	%/V	
Load Regulation	LDR	$I_O = 1\text{mA}$ to 300mA	—	30	60	mV	
Short Circuit Current	I_{SC}	$V_O = 0\text{V}$	—	130	—	mA	
Temperature Coefficient	T_C	—	—	40	—	ppm/ $^\circ\text{C}$	
Over Temperature Shutdown	OTS	$I_O = 1\text{mA}$	—	+150	—	$^\circ\text{C}$	
Over Temperature Hysteresis	OTH	$I_O = 1\text{mA}$	—	+30	—	$^\circ\text{C}$	
Power Supply Ripple Rejection	PSRR	$I_O = 100\text{mA}$ $C_{BYP} = 10\text{nF}$	f = 100Hz	—	70	—	dB
			f = 1kHz	—	65	—	
Output Noise	V_N	f = 10Hz to 100kHz, $C_{BYP} = 10\text{nF}$	—	50	—	μV_{RMS}	
EN Input High Threshold	V_{IH}	$V_{IN} = 2.5\text{V}$ to 5V	1.5	—	—	V	
EN Input Low Threshold	V_{IL}	$V_{IN} = 2.5\text{V}$ to 5V	—	—	0.3	V	
Shutdown Current	I_{SD}	$V_{EN} = 0\text{V}$	—	0.01	1	μA	

Notes: 1. Output current is limited by P_D , maximum $I_O = 400\text{mW} / (V_{IN(MAX)} - V_O)$.

NOT RECOMMENDED FOR NEW DESIGN

Typical Performance Characteristics (@ $T_A = +25^\circ\text{C}$, $C_{IN} = 1\mu\text{F}$, $C_O = 2.2\mu\text{F}$, $V_O = 1.2\text{V}$, unless otherwise specified.)

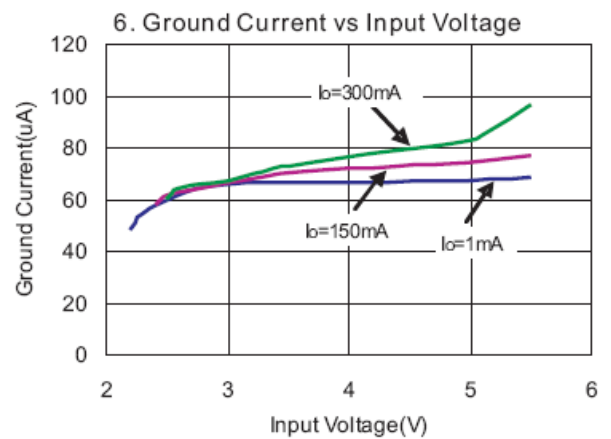
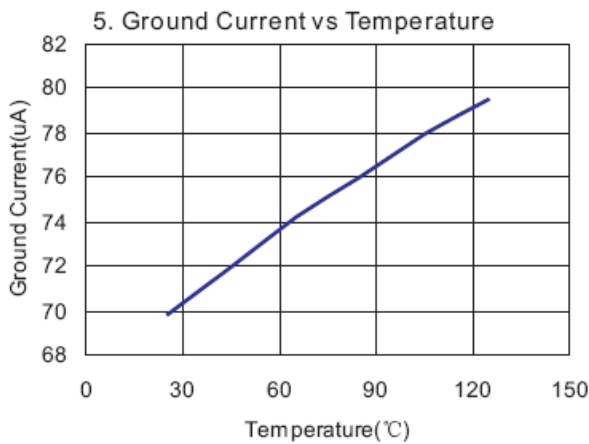
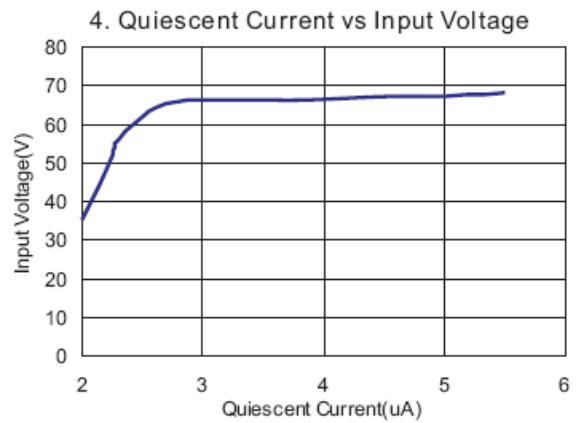
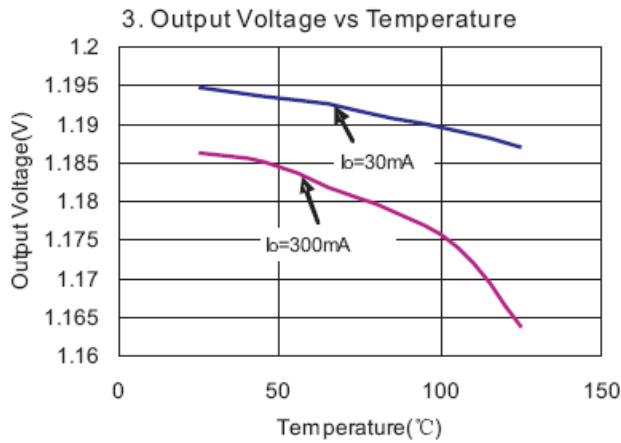
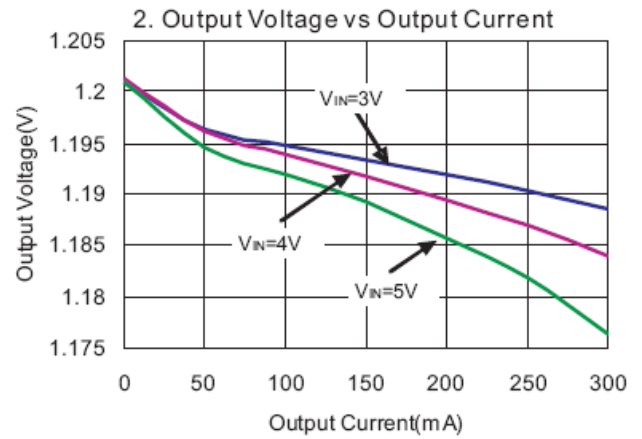
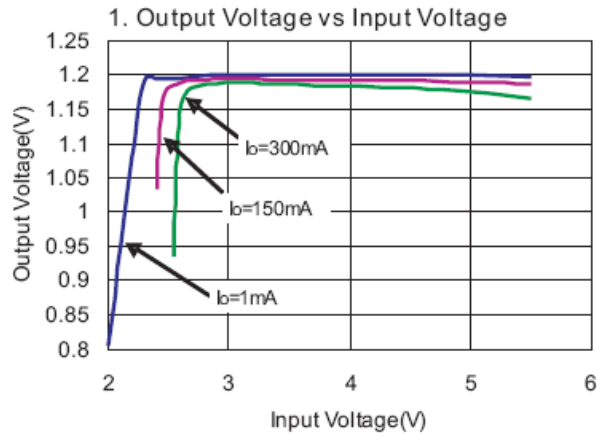

Typical Performance Characteristics (cont.) (@ $T_A = +25^\circ\text{C}$, $C_{IN} = 1\mu\text{F}$, $C_O = 2.2\mu\text{F}$, $V_O = 1.2\text{V}$, unless otherwise specified.)

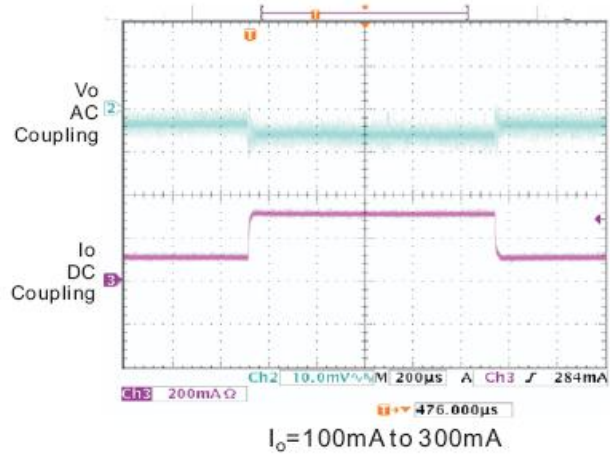
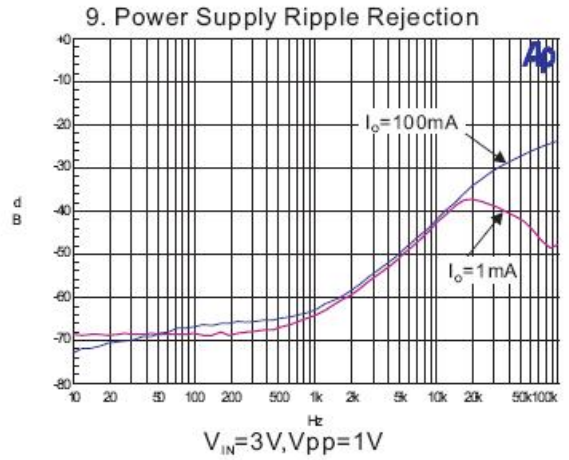
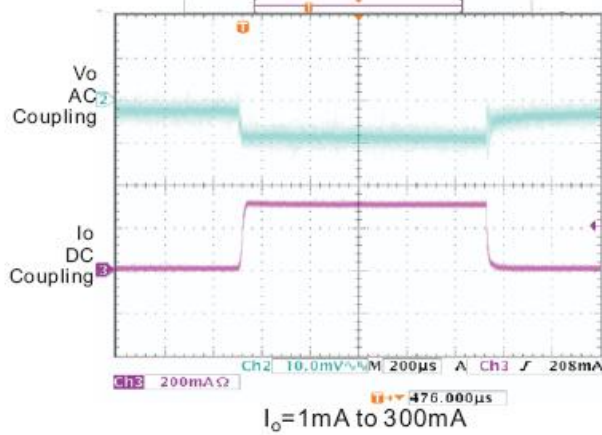
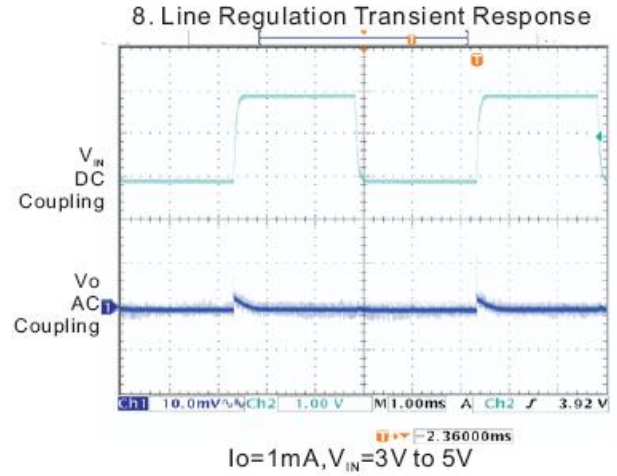
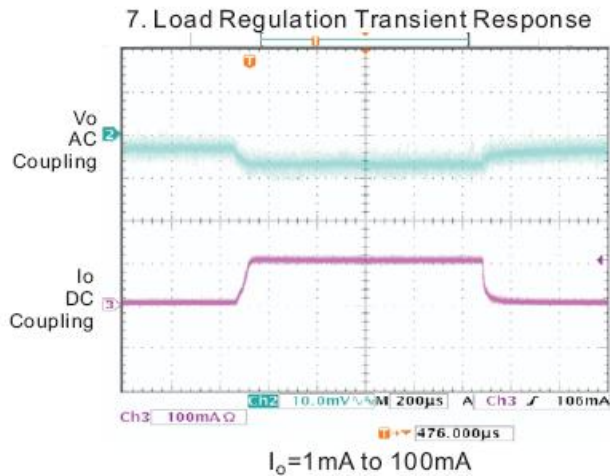

Application Information

Capacitor Selection and Regulator Stability

Similar to any low dropout regulator, the external capacitors used with the PAM3112 must be carefully selected for regulator stability and performance.

A capacitor C_{IN} of more than $1\mu\text{F}$ can be used at the PAM3112 input pin, while there is no upper limit for the capacitance of C_{IN} . Please note that the distance between C_{IN} and the input pin of the PAM3112 should not exceed 0.5 inch. Ceramic capacitors are suitable for the PAM3112. Capacitors with larger values and lower ESR (equivalent series resistance) provide better PSRR and line-transient response.

The PAM3112 is designed specifically to work with low ESR ceramic output capacitors in order to save space and improve performance. Using an output ceramic capacitor whose value is $>2.2\mu\text{F}$ with $\text{ESR} > 5\text{m}\Omega$ ensures stability.

A 10nF bypass capacitor connected to BYP pin is suggested for suppressing output noise. The capacitor, in series connection with an internal 200k Ω resistor, forms a low-pass filter for noise reduction. Increasing the capacitance will slightly decrease the output noise, but increase the startup time.

Load Transient Consideration

Curve 7 of the PAM3112 load-transient response on page 6 shows two components of the output response, a DC shift from the output impedance due to the load current change and transient response. The DC shift is quite small due to excellent load regulation of the PAM3112. The transient spike, resulting from a step change in the load current from 1mA to 300mA, is 20mV. The ESR of the output capacitor is critical to the transient spike. A larger capacitance along with smaller ESR results in a smaller spike.

Shutdown Input Operation

The PAM3112 is shut down by pulling the EN input low and turned on by tying the EN input to V_{IN} or leaving the EN input floating.

Internal P-Channel Pass Transistor

The PAM3112 features a 0.75 Ω P-Channel MOSFET device as a pass transistor. The P-MOS pass transistor enables the PAM3112 to consume only 65 μA of ground current during low dropout, light-load, or heavy-load operation. These features increase the battery operation life time.

Input-Output (Dropout) Voltage

A regulator's minimum input-output voltage difference (or dropout voltage) determines the lowest usable supply voltage. The PAM3112 has a typical 300mV dropout voltage. In battery-powered systems, this will determine the useful end-of-life battery voltage.

Current Limit and Short Circuit Protection

The PAM3112 features a current limit, which monitors and controls the gate voltage of the pass transistor. The output current can be limited to 400mA by regulating the gate voltage. The PAM3112 also has a built-in short circuit current limit.

Thermal Considerations

Thermal protection limits power dissipation in the PAM3112. When the junction temperature exceeds $+150^{\circ}\text{C}$, the OTP (Over Temperature Protection) starts the thermal shutdown and turns the pass transistor off. The pass transistor resumes operation after the junction temperature drops below $+120^{\circ}\text{C}$.

For continuous operation, the junction temperature should be maintained below $+125^{\circ}\text{C}$.

The power dissipation is defined as:

$$P_D = (V_{IN} - V_{OUT}) * I_O + V_{IN} * I_{GND}$$

The maximum power dissipation depends on the thermal resistance of IC package, PCB layout, the rate of surrounding airflow and temperature difference between junction and ambient. The maximum power dissipation can be calculated by the following formula:

$$P_{D(\text{MAX})} = (T_{J(\text{MAX})} - T_A) / \theta_{JA}$$

Application Information (cont.)

Thermal Considerations

Where $T_{J(MAX)}$ is the maximum allowable junction temperature $+125^{\circ}C$, T_A is the ambient temperature and is the thermal resistance from the junction to the ambient.

For example, as θ_{JA} is $+250^{\circ}C/W$ for the SOT23 and TSOT25 packages based on the standard JEDEC 51-3 for a single-layer thermal test board, the maximum power dissipation at $T_A = +25^{\circ}C$ can be calculated by following formula:

$$P_{D(MAX)} = (125^{\circ}C - 25^{\circ}C) / 250 = 0.4W \text{ SOT-23}$$

It is also useful to calculate the junction temperature of the PAM3112 under a set of specific condition. Suppose the input voltage $V_{IN} = 3.3V$, the output current $I_O = 150mA$ and the case temperature $T_A = +40^{\circ}C$ measured by a thermal couple during operation, the power dissipation is defined as:

$$P_D = (3.3V - 1.2V) * 150mA + 3.3V * 70\mu A \cong 315mW$$

And the junction temperature, T_J can be calculated as follows:

$$T_J = T_A + P_D * \theta_{JA}$$

$$T_J = 40^{\circ}C + 0.35W * 250^{\circ}C/W$$

$$= 40^{\circ}C + 78.75^{\circ}C$$

$$= 118.75^{\circ}C < T_{J(MAX)} = +125^{\circ}C$$

For this application, T_J is lower than the absolute maximum operating junction temperature $+125^{\circ}C$, so it is safe to use the PAM3112 in this configuration.

NOT RECOMMENDED FOR NEW DESIGN

Ordering Information

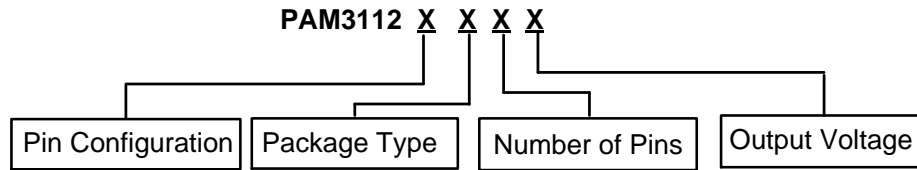

Pin Configuration		Package Type	Number of Pins	Output Voltage
A Type: 1. VOUT 2. GND 3. VIN	F Type: 1. EN 2. GND 3. VOUT 4. VIN	A: SOT23/TSOT25 C: SOT-89 U: SC70	A: 3 K: 4 B: 5 F: 6	120: 1.2V 130: 1.3V
B Type: 1. GND 2. VOUT 3. VIN	G Type: 1. VIN 2. VOUT 3. GND			
D Type: 1. VIN 2. GND 3. EN 4. BYP 5. VOUT	H Type: 1. GND 2. VIN 3. VOUT			

Part Number	Output Voltage	Marking	Package Type	Standard Package
PAM3112AAA120	1.2V	AOBYW	SOT23	3000 Units/ Tape&Reel
PAM3112BAA120	1.2V	AOBYW	SOT23	3000 Units/ Tape&Reel
PAM3112DAB120	1.2V	AOBYW	TSOT25	3000 Units/ Tape&Reel
PAM3112ACA120	1.2V	P3112B XXXYW	SOT89-3	1000 Units/ Tape&Reel
PAM3112HCA120	1.2V	P3112B XXXYW	SOT89-3	1000 Units/ Tape&Reel
PAM3112GUA120	1.2V	AOBYW	SC70-3	3000 Units/ Tape&Reel
PAM3112FUK120	1.2V	AOBYW	SC70-4	3000 Units/ Tape&Reel
PAM3112DUB120	1.2V	AOBYW	SC70-5	3000 Units/ Tape&Reel
PAM3112AAA130	1.3V	AOWYW	SOT23	3000 Units/ Tape&Reel
PAM3112BAA130	1.3V	AOWYW	SOT23	3000 Units/ Tape&Reel
PAM3112DAB130	1.3V	AOWYW	TSOT25	3000 Units/ Tape&Reel
PAM3112ACA130	1.3V	P3112W XXXYW	SOT89-3	1000 Units/ Tape&Reel
PAM3112HCA130	1.3V	P3112W XXXYW	SOT89-3	1000 Units/ Tape&Reel
PAM3112GUA130	1.3V	AOWYW	SC70-3	3000 Units/ Tape&Reel
PAM3112FUK130	1.3V	AOWYW	SC70-4	3000 Units/ Tape&Reel
PAM3112DUB130	1.3V	AOWYW	SC70-5	3000 Units/ Tape&Reel

Marking Information

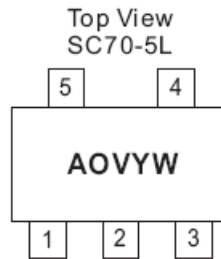
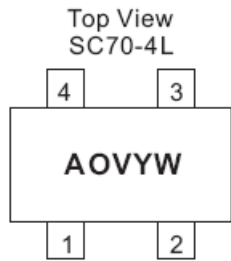
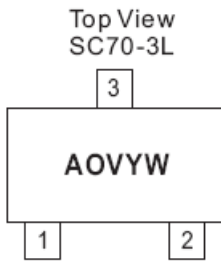
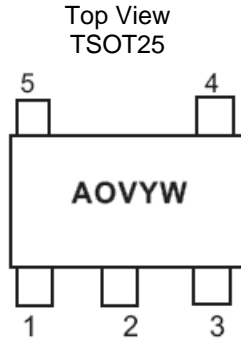
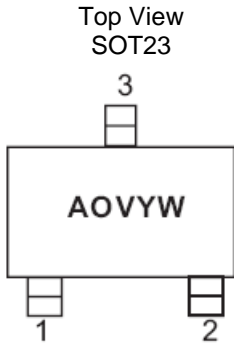

AO: Product Code
of PAM3112
X: Internal Code
V: Voltage Code
Y: Year
W: Week

NOT RECOMMENDED FOR NEW DESIGN

Package Outline Dimensions (All dimensions in mm.)

SOT23

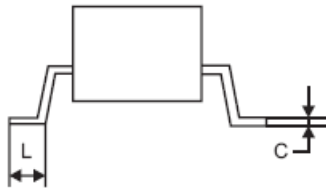
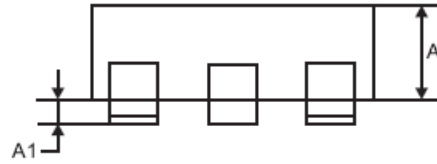
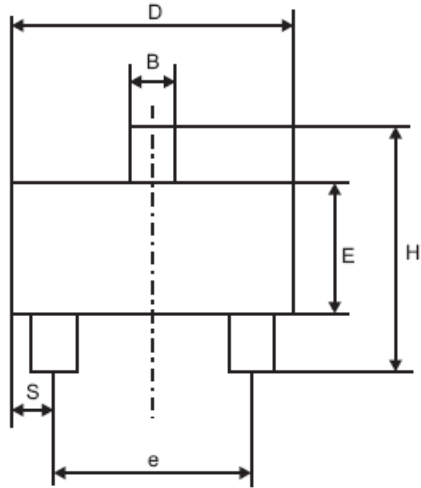

Dim	Millimeters		
	Min.	Typ.	Max.
A	1.00	1.15	1.30
A1	0.00	0.05	0.10
B	0.35	0.43	0.51
C	0.10	0.175	0.25
D	2.70	2.90	3.10
E	1.40	1.60	1.80
e	1.90BSC		
H	2.40	2.70	3.00
L	0.37		

NOT REC
FOR NEW

Package Outline Dimensions (cont.) (All dimensions in mm.)

TSOT25

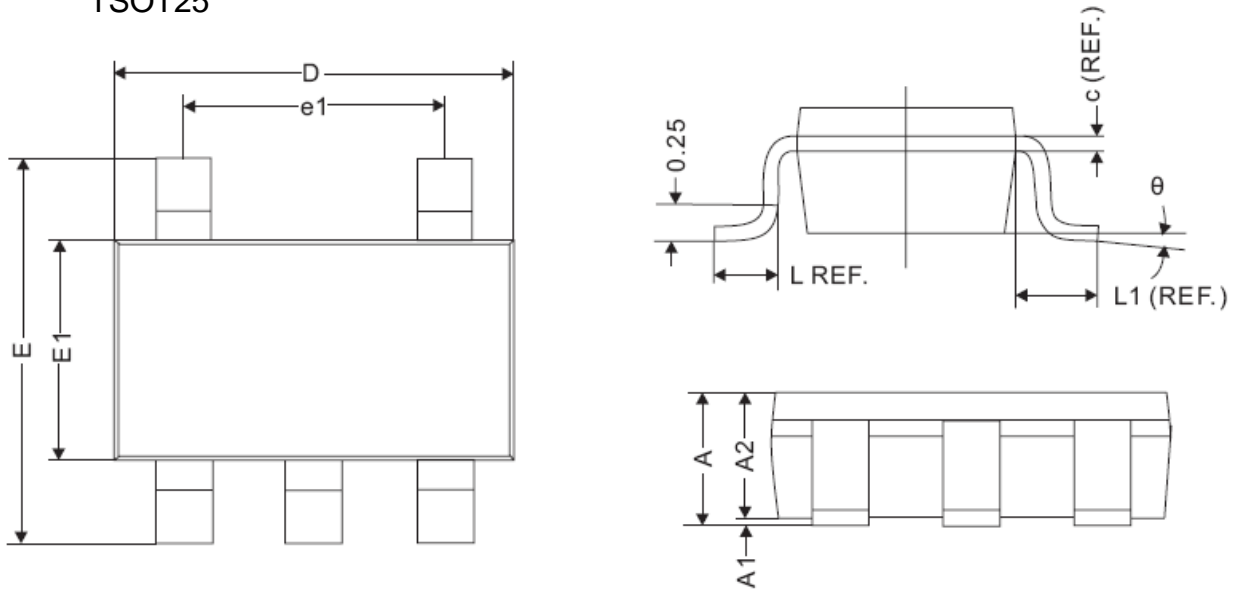

REF.	Millimeter		
	Min	Nom	Max
A	1.10MAX		
A1	0	0.05	0.10
A2	0.70	1.00	1.295
c	0.12REF.		
D	2.70	2.90	3.10
E	2.60	2.80	3.00
E1	1.40	1.60	1.80
L	0.45REF.		
L1	0.60REF.		
θ	0°	5°	10°
b	0.30	0.40	0.50
e	0.95REF.		
e1	1.90REF.		

Package Outline Dimensions (cont.) (All dimensions in mm.)

SOT89-3

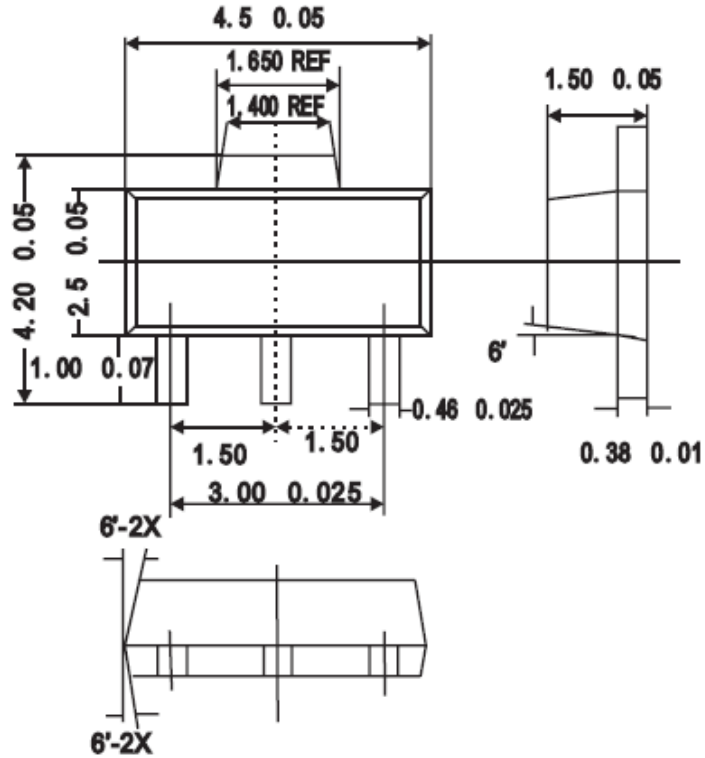

(Unit : mm)

NOT FOR

Package Outline Dimensions (cont.) (All dimensions in mm.)

SC70-4

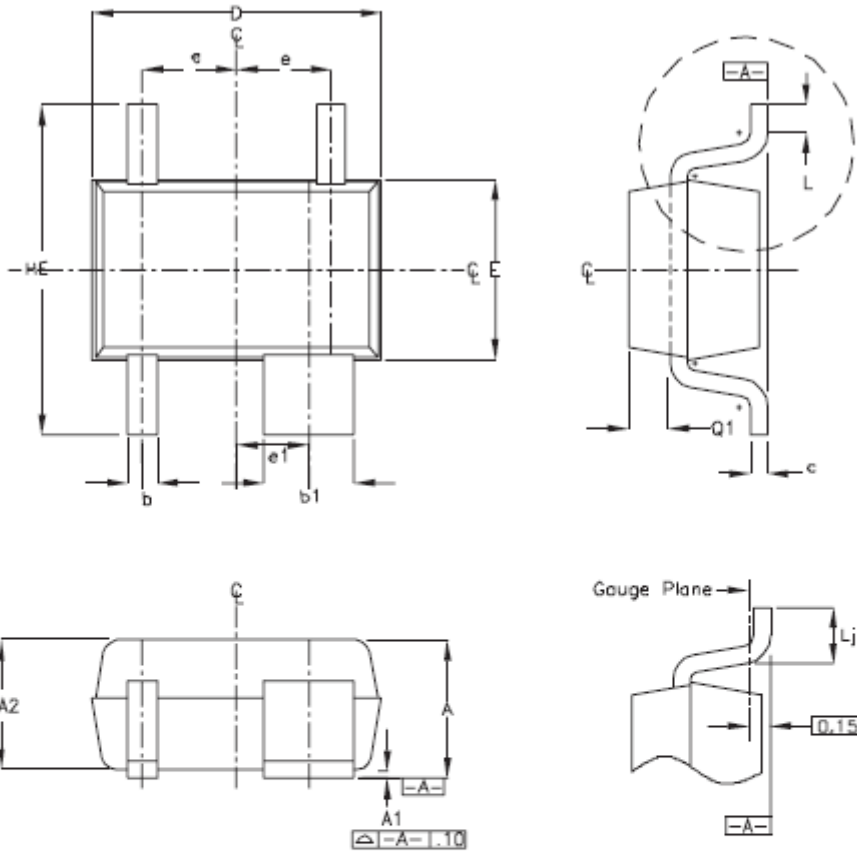

SYMBOL	MIN	MAX
e	0.65 BSC	
e1	0.50 BSC	
D	1.80	2.20
b	0.15	0.30
b1	0.575	0.700
E	1.15	1.35
HE	1.80	2.40
Q1	0.10	0.40
A2	0.80	1.00
A1	0.00	0.10
A	0.80	1.10
c	0.10	0.18
L	0.10	0.30
Lj	0.26	0.46

- 1) ALL DIMENSIONS ARE IN MILLIMETERS
- 2) DIMENSIONS ARE INCLUSIVE OF PLATING
- 3) DIMENSIONS ARE EXCLUSIVE OF MOLD FLASH & METAL BURR
- 4) CUSTOM LEADCOUNT VARIATION OF JEITA SC70

Package Outline Dimensions (cont.) (All dimensions in mm.)

SC70-5

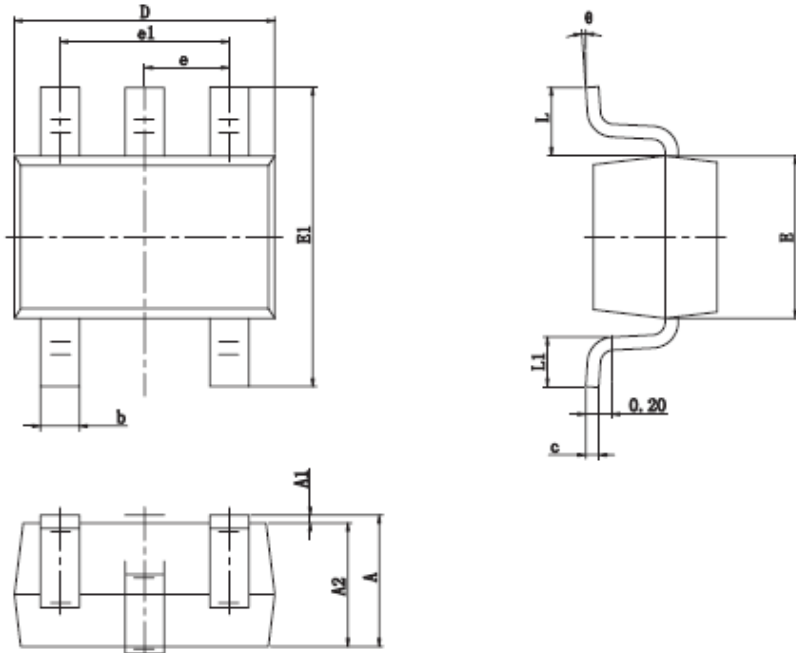

Symbol	Dimensions In Millimeters		Dimensions In Inches	
	Min	Max	Min	Max
A	0.900	1.100	0.035	0.043
A1	0.000	0.100	0.000	0.004
A2	0.900	1.000	0.035	0.039
b	0.150	0.350	0.006	0.014
c	0.080	0.150	0.003	0.006
D	2.000	2.200	0.079	0.087
E	1.150	1.350	0.045	0.053
E1	2.150	2.450	0.085	0.096
e	0.650 TYP		0.026 TYP	
e1	1.200	1.400	0.047	0.055
L	0.525 REF		0.021 REF	
L1	0.260	0.460	0.010	0.018
θ	0	8	0	8

NC
FC

IMPORTANT NOTICE

DIODES INCORPORATED MAKES NO WARRANTY OF ANY KIND, EXPRESS OR IMPLIED, WITH REGARDS TO THIS DOCUMENT, INCLUDING, BUT NOT LIMITED TO, THE IMPLIED WARRANTIES OF MERCHANTABILITY AND FITNESS FOR A PARTICULAR PURPOSE (AND THEIR EQUIVALENTS UNDER THE LAWS OF ANY JURISDICTION).

Diodes Incorporated and its subsidiaries reserve the right to make modifications, enhancements, improvements, corrections or other changes without further notice to this document and any product described herein. Diodes Incorporated does not assume any liability arising out of the application or use of this document or any product described herein; neither does Diodes Incorporated convey any license under its patent or trademark rights, nor the rights of others. Any Customer or user of this document or products described herein in such applications shall assume all risks of such use and will agree to hold Diodes Incorporated and all the companies whose products are represented on Diodes Incorporated website, harmless against all damages.

Diodes Incorporated does not warrant or accept any liability whatsoever in respect of any products purchased through unauthorized sales channel. Should Customers purchase or use Diodes Incorporated products for any unintended or unauthorized application, Customers shall indemnify and hold Diodes Incorporated and its representatives harmless against all claims, damages, expenses, and attorney fees arising out of, directly or indirectly, any claim of personal injury or death associated with such unintended or unauthorized application.

Products described herein may be covered by one or more United States, international or foreign patents pending. Product names and markings noted herein may also be covered by one or more United States, international or foreign trademarks.

This document is written in English but may be translated into multiple languages for reference. Only the English version of this document is the final and determinative format released by Diodes Incorporated.

LIFE SUPPORT

Diodes Incorporated products are specifically not authorized for use as critical components in life support devices or systems without the express written approval of the Chief Executive Officer of Diodes Incorporated. As used herein:

A. Life support devices or systems are devices or systems which:

1. are intended to implant into the body, or
2. support or sustain life and whose failure to perform when properly used in accordance with instructions for use provided in the labeling can be reasonably expected to result in significant injury to the user.

B. A critical component is any component in a life support device or system whose failure to perform can be reasonably expected to cause the failure of the life support device or to affect its safety or effectiveness.

Customers represent that they have all necessary expertise in the safety and regulatory ramifications of their life support devices or systems, and acknowledge and agree that they are solely responsible for all legal, regulatory and safety-related requirements concerning their products and any use of Diodes Incorporated products in such safety-critical, life support devices or systems, notwithstanding any devices- or systems-related information or support that may be provided by Diodes Incorporated. Further, Customers must fully indemnify Diodes Incorporated and its representatives against any damages arising out of the use of Diodes Incorporated products in such safety-critical, life support devices or systems.

Copyright © 2016, Diodes Incorporated

www.diodes.com

Looking for pricing, stock, or lifecycle information?

Click below to explore more details on WIN SOURCE:

- ⊖ [View PAM3112DAB120 on WIN SOURCE](#)
- ⊖ [Diodes Incorporated Information](#)

Optimize Your Supply Chain with WIN SOURCE Solutions

- ✓ Global Sourcing Solution
- ✓ Obsolete Management
- ✓ Cost Control Management
- ✓ Shortage Management
- ✓ Alternative Solution
- ✓ Excess Inventory Management