

PC9D10

Ultra-high Speed Response, 2-channel OPIC Photocoupler

■ Features

1. Built-in 2-channel
2. Ultra-high speed response
(t_{PHL} , t_{PLH} : TYP. 50ns at $R_L = 350\Omega$)
3. Isolation voltage between input and output
(V_{ISO} : 2 500V_{rms})
4. Low input current drive (I_{FHL} : MAX. 5mA)
5. Instantaneous common mode rejection
voltage (CM_H : TYP. 500V/ μ s)
6. Recognized by UL file No. 64380

■ Applications

1. Computer peripherals high speed interface
for microcomputer systems
2. High speed line receivers
3. Digital audio equipment
4. Interface with various data transfer equipment

■ Outline Dimensions

(Unit : mm)

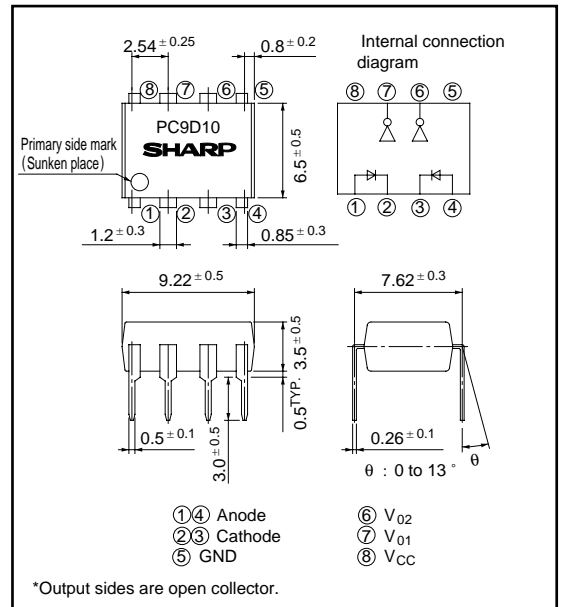

* "OPIC" (Optical IC) is a trademark of the SHARP Corporation.
An OPIC consists of a light-detecting element and signal-processing circuit integrated onto a single chip.

■ Absolute Maximum Ratings

($T_a = 25^\circ\text{C}$)

Parameter		Symbol	Rating	Unit
Input	*1 *2 Forward current	I_F	15	mA
	*2 Reverse voltage	V_R	5	V
	*1 *2 Power dissipation	P	40	mW
Output	*3 Supply voltage	V_{CC}	7	V
	*2 High level output voltage	V_{OH}	7	V
	*2 Low level output current	I_{OL}	16	mA
	Collector power dissipation	P_C	60	mW
*4 Isolation voltage		V_{iso}	2 500	V _{rms}
Operating temperature		T_{opr}	0 to + 70	$^\circ\text{C}$
Storage temperature		T_{stg}	- 55 to + 125	$^\circ\text{C}$
*5 Soldering temperature		T_{sol}	260	$^\circ\text{C}$

*1 $T_a = 0$ to 70°C

*2 Each channel

*3 For 1 minute max.

*4 AC for 1 minute, 40 to 60% RH. Apply the specified voltage between the whole of the electrode pins on the input side and the whole of the electrode pins on the output side.

*5 2mm or more away from the lead base for 10 seconds or less

■ Electro-optical Characteristics

(Unless otherwise specified, $T_a = 0 \text{ to } +70^\circ\text{C}$)

Parameter		Symbol	Conditions	MIN.	TYP.	MAX.	Unit	
Input	Forward voltage	V_F	$T_a = 25^\circ\text{C}, I_F = 10\text{mA}$	-	1.6	1.75	V	
	Reverse current	I_R	$T_a = 25^\circ\text{C}, V_R = 5\text{V}$	-	-	10	μA	
	Terminal capacitance	C_t	$T_a = 25^\circ\text{C}, V = 0, f = 1\text{MHz}$	-	60	250	pF	
Output	High level output current	I_{OH}	$V_{CC} = V_O = 5.5\text{V}, I_F = 250\mu\text{A}$	-	2	250	μA	
	Low level output voltage	V_{OL}	$V_{CC} = 5.5\text{V}, I_F = 5\text{mA}, I_{OL} = 13\text{mA}$	-	0.4	0.6	V	
	High level supply current	I_{CCH}	$V_{CC} = 5.5\text{V}, I_F = 0$	-	14	30	mA	
	Low level supply current	I_{CCL}	$V_{CC} = 5.5\text{V}, I_F = 10\text{mA}$	-	26	36	mA	
Transfer characteristics	“High→Low” threshold input current	I_{FHL}	$V_{CC} = 5\text{V}, V_O = 0.8\text{V}, R_L = 350\Omega$	-	2.5	5	mA	
	Isolation resistance	R_{ISO}	$T_a = 25^\circ\text{C}, \text{DC}500\text{V}, 40 \text{ to } 60\% \text{ RH}$	5×10^{10}	10^{11}	-	Ω	
	Floating capacitance	C_f	$T_a = 25^\circ\text{C}, V = 0, f = 1\text{MHz}$	-	0.6	-	pF	
	Response time	“High→Low” propagation delay time	t_{PHL}	$T_a = 25^\circ\text{C}, V_{CC} = 5\text{V}$ Fig.1	-	50	75	ns
		“Low→High” propagation delay time	t_{PLH}	$R_L = 350\Omega, C_L = 15\text{pF}$	-	50	75	ns
		Rise time, Fall time	t_r, t_f	$I_F = 7.5\text{mA}$	-	30	60	ns
	CMR	Instantaneous common mode rejection voltage “High level output”	CM_H	$T_a = 25^\circ\text{C}, V_{CC} = 5\text{V}, V_{O(MIN)} = 2\text{V}$ Fig.2 $V_{CM} = 10\text{V}, R_L = 350\Omega, I_F = 0$	100	500	-	V/ μs
Instantaneous common mode rejection voltage “Low level output”		CM_L	Fig.2 $T_a = 25^\circ\text{C}, V_{CC} = 5\text{V}, V_{O(MAX)} = 0.8\text{V}$ $V_{CM} = 10\text{V}, R_L = 350\Omega, I_F = 5\text{mA}$	- 100	- 500	-	V/ μs	

All typical values : at $T_a = 25^\circ\text{C}, V_{CC} = 5\text{V}$

■ Recommended Operating Conditions

Parameter	Symbol	MIN.	MAX.	Unit
Low level input current	I_{FL}	0	250	μA
High level input current	I_{FH}	7	15	mA
Supply voltage	V_{CC}	4.5	5.5	V
Fanout (TTL load)	N	-	8	-
Operating temperature	T_{opr}	0	70	$^\circ\text{C}$

Connect a ceramic by-pass capacitor (0.01 to 0.1 μF) between V_{CC} and GND at the position within 1cm from pin.

Fig. 1 Test Circuit for t_{PHL} , t_{PLH} , t_r and t_f

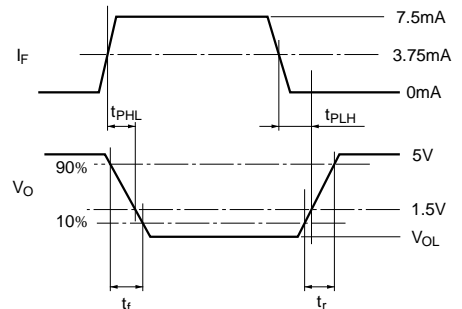
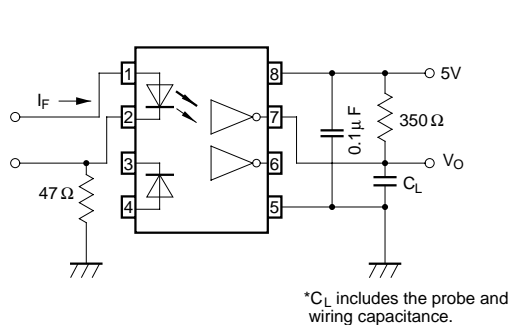

Fig. 2 Test Circuit for CM_H and CM_L

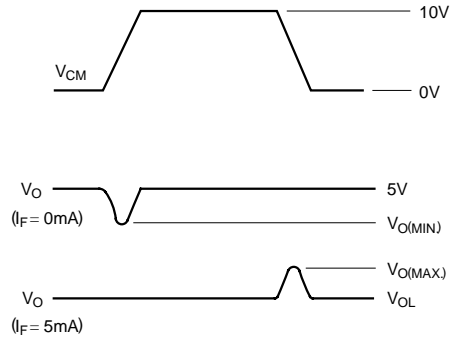
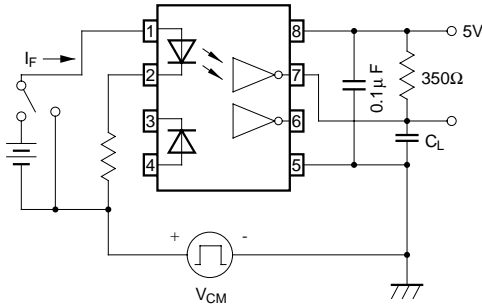

Fig. 3 Collector Power Dissipation vs. Ambient Temperature

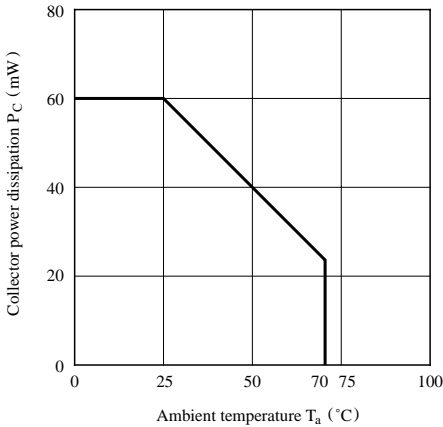

Fig. 4 Forward Current vs. Forward Voltage

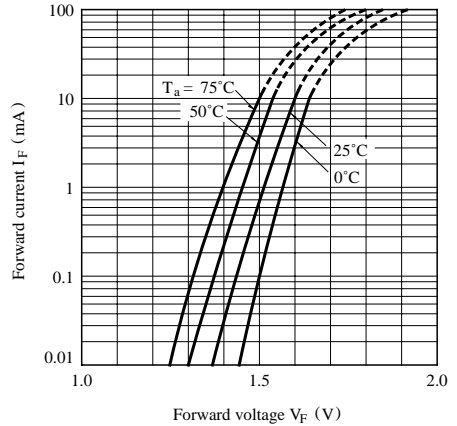

Fig. 5 High Level Output Current vs. Ambient Temperature

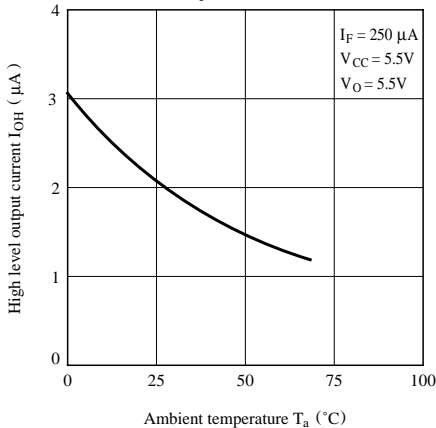

Fig. 6 Low Level Output Voltage vs. Ambient Temperature

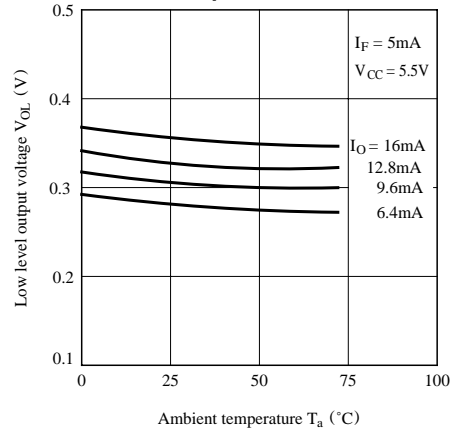

Fig. 7-a Output Voltage vs. Forward Current

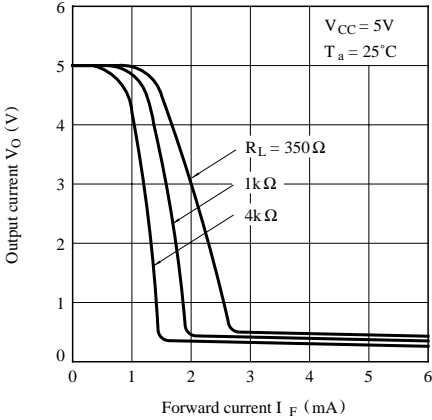

Fig. 7-b Output Voltage vs. Forward Current (Ambient Temp. Characteristics)

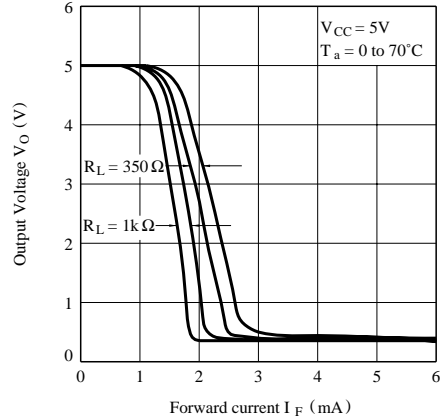

Fig. 8 Propagation Delay Time vs. Forward Current

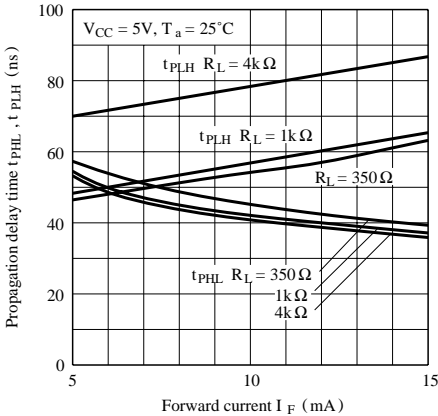

Fig. 9 Propagation Delay Time vs. Ambient Temperature

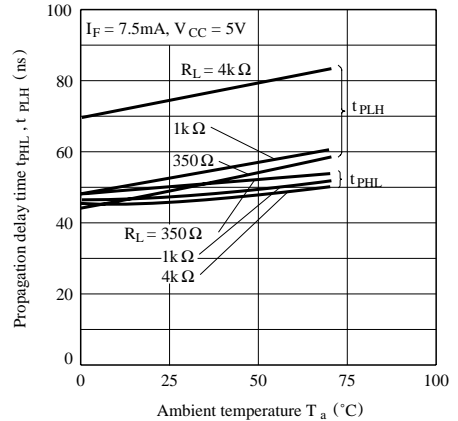
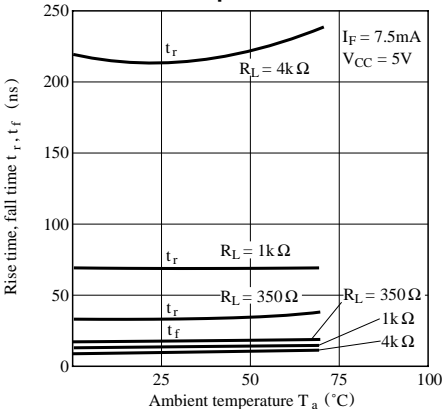

Fig. 10 Rise Time, Fall Time vs. Ambient Temperature



■ Precautions for Use



- (1) Handle this product the same as with other integrated circuits against static electricity.
- (2) As for other general cautions, refer to the chapter "Precautions for Use"

NOTICE







- The circuit application examples in this publication are provided to explain representative applications of SHARP devices and are not intended to guarantee any circuit design or license any intellectual property rights. SHARP takes no responsibility for any problems related to any intellectual property right of a third party resulting from the use of SHARP's devices.
- Contact SHARP in order to obtain the latest device specification sheets before using any SHARP device. SHARP reserves the right to make changes in the specifications, characteristics, data, materials, structure, and other contents described herein at any time without notice in order to improve design or reliability. Manufacturing locations are also subject to change without notice.
- Observe the following points when using any devices in this publication. SHARP takes no responsibility for damage caused by improper use of the devices which does not meet the conditions and absolute maximum ratings to be used specified in the relevant specification sheet nor meet the following conditions:
 - (i) The devices in this publication are designed for use in general electronic equipment designs such as:
 - Personal computers
 - Office automation equipment
 - Telecommunication equipment [terminal]
 - Test and measurement equipment
 - Industrial control
 - Audio visual equipment
 - Consumer electronics
 - (ii) Measures such as fail-safe function and redundant design should be taken to ensure reliability and safety when SHARP devices are used for or in connection with equipment that requires higher reliability such as:
 - Transportation control and safety equipment (i.e., aircraft, trains, automobiles, etc.)
 - Traffic signals
 - Gas leakage sensor breakers
 - Alarm equipment
 - Various safety devices, etc.
 - (iii) SHARP devices shall not be used for or in connection with equipment that requires an extremely high level of reliability and safety such as:
 - Space applications
 - Telecommunication equipment [trunk lines]
 - Nuclear power control equipment
 - Medical and other life support equipment (e.g., scuba).
- Contact a SHARP representative in advance when intending to use SHARP devices for any "specific" applications other than those recommended by SHARP or when it is unclear which category mentioned above controls the intended use.
- If the SHARP devices listed in this publication fall within the scope of strategic products described in the Foreign Exchange and Foreign Trade Control Law of Japan, it is necessary to obtain approval to export such SHARP devices.
- This publication is the proprietary product of SHARP and is copyrighted, with all rights reserved. Under the copyright laws, no part of this publication may be reproduced or transmitted in any form or by any means, electronic or mechanical, for any purpose, in whole or in part, without the express written permission of SHARP. Express written permission is also required before any use of this publication may be made by a third party.
- Contact and consult with a SHARP representative if there are any questions about the contents of this publication.

Looking for pricing, stock, or lifecycle information?

Click below to explore more details on WIN SOURCE:

-  [View PC9D10 on WIN SOURCE](#)
-  [Sharp Microelectronics](#) Information

Optimize Your Supply Chain with WIN SOURCE Solutions

-  Global Sourcing Solution
-  Obsolete Management
-  Cost Control Management
-  Shortage Management
-  Alternative Solution
-  Excess Inventory Management