



THE DATASHEET OF PCA9515BDGKR



PCA9515B Dual Bidirectional I²C Bus and SMBus Repeater

1 Features

- Two-Channel Bidirectional Buffers
- I²C Bus and SMBus Compatible
- Support for I²C Standard Mode (100-kHz) and Fast Mode (400-kHz)
- Active-High Repeater-Enable Input
- Open-Drain I²C Input and Output
- 5.5-V Tolerant I²C Input and Output and Enable Input Support Mixed-Mode Signal Operation
- Lockup-Free Operation
- Accommodates Standard Mode, Fast Mode I²C Devices, and Multiple Masters
- Supports Arbitration and Clock Stretching Across Repeater
- Powered-Off High-Impedance I²C Pins
- Latch-Up Performance Exceeds 100-mA Per JESD 78, Class I
- ESD Protection Exceeds JESD 22
 - 2000-V Human-Body Model (A114-A)
 - 1000-V Charged-Device Model (C101)

2 Applications

- Servers
- Routers (Telecom Switching Equipment)
- Industrial Equipment
- Products with Many I²C Slaves and Long PCB Traces

3 Description

The PCA9515B is a BiCMOS dual bidirectional buffer integrated circuit intended for I²C bus and SMBus applications. The device contains two identical bidirectional open-drain buffer circuits that enables I²C and similar bus systems to be extended (or add slaves) without degrading system performance. The dual bidirectional I²C buffer is operational at 2.3 V to 3.6 V V_{CC}.

The PCA9515B buffers both the serial data (SDA) and serial clock (SCL) signals on the I²C bus, while retaining all the operating modes and features of the I²C system. The device allows two buses, of 400-pF bus capacitance, to be connected in an I²C application.

Device Information⁽¹⁾

PART NUMBER	PACKAGE	BODY SIZE (NOM)
PCA9515B	VSSOP (8)	3.00 mm x 3.00 mm

(1) For all available packages, see the orderable addendum at the end of the data sheet.

Simplified Schematic

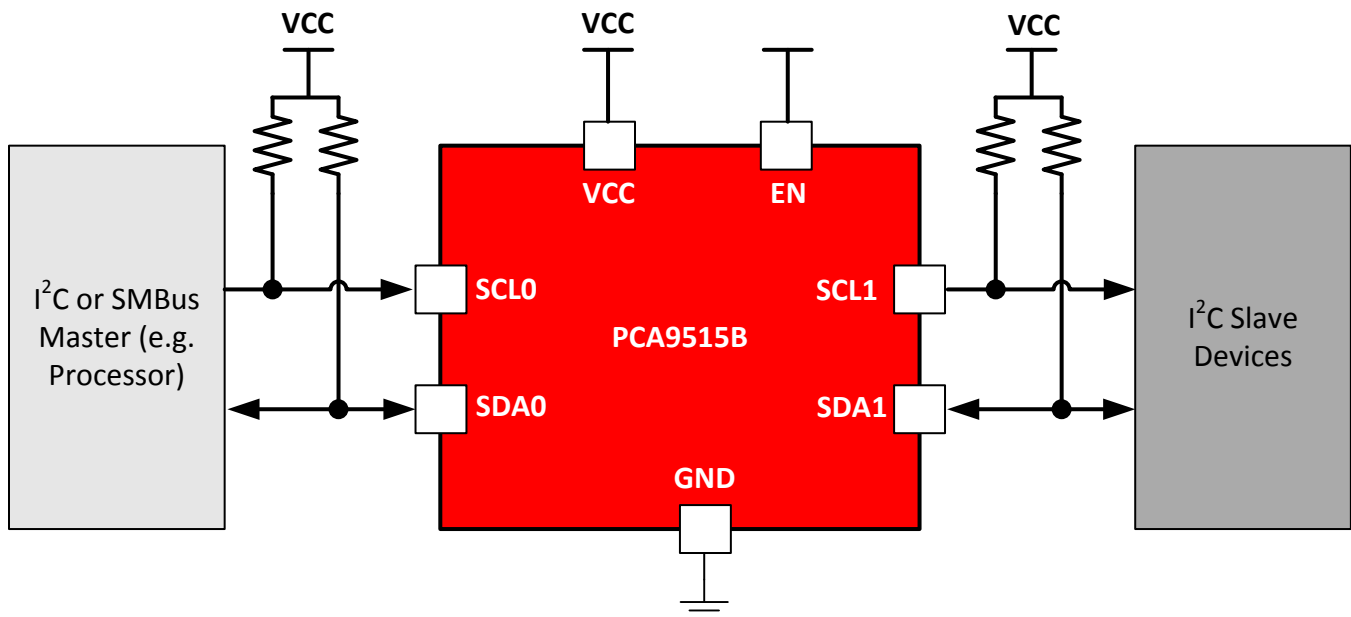

Table of Contents

1	Features	1	8.2	Functional Block Diagram	9
2	Applications	1	8.3	Feature Description.....	9
3	Description	1	8.4	Device Functional Modes.....	10
4	Revision History	2	9	Application and Implementation	11
5	Pin Configuration and Functions	3	9.1	Application Information.....	11
6	Specifications	4	9.2	Typical Application	11
6.1	Absolute Maximum Ratings	4	10	Power Supply Recommendations	12
6.2	ESD Ratings	4	11	Layout	13
6.3	Recommended Operating Conditions.....	4	11.1	Layout Guidelines	13
6.4	Thermal Information	4	11.2	Layout Example	13
6.5	Electrical Characteristics.....	5	12	Device and Documentation Support	14
6.6	Timing Requirements.....	5	12.1	Documentation Support	14
6.7	Switching Characteristics.....	5	12.2	Community Resources.....	14
6.8	Typical Characteristics.....	6	12.3	Trademarks	14
7	Parameter Measurement Information	7	12.4	Electrostatic Discharge Caution.....	14
8	Detailed Description	8	12.5	Glossary	14
8.1	Overview	8	13	Mechanical, Packaging, and Orderable Information	14

4 Revision History

NOTE: Page numbers for previous revisions may differ from page numbers in the current version.

Changes from Revision A (May 2013) to Revision B	Page
<ul style="list-style-type: none"> Added <i>Device Information</i> table, <i>ESD Ratings</i> table, <i>Feature Description</i> section, <i>Device Functional Modes</i>, <i>Application and Implementation</i> section, <i>Power Supply Recommendations</i> section, <i>Layout</i> section, <i>Device and Documentation Support</i> section, and <i>Mechanical, Packaging, and Orderable Information</i> section. 	1
<ul style="list-style-type: none"> Deleted the ordering information. See POA at the end of the datasheet..... 	1

Changes from Original (March 2012) to Revision A	Page
<ul style="list-style-type: none"> Updated the V_{OL} and $V_{OL} - V_{ILC}$ specifications..... 	5

5 Pin Configuration and Functions

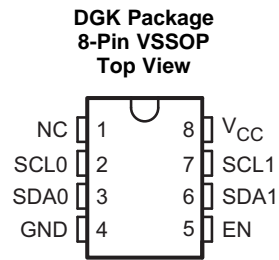

NC - No internal connection

Pin Functions

PIN		I/O	DESCRIPTION
NO.	NAME		
1	NC	—	No internal connection
2	SCL0	I/O	Serial clock bus 0
3	SDA0	I/O	Serial data bus 0
4	GND	—	Supply ground
5	EN	I	Active-high repeater enable input
6	SDA1	I/O	Serial data bus 1
7	SCL1	I/O	Serial clock bus 1
8	V _{CC}	—	Supply power

6 Specifications

6.1 Absolute Maximum Ratings

over operating free-air temperature range (unless otherwise noted) ⁽¹⁾

		MIN	MAX	UNIT
V _{CC}	Supply voltage	-0.5	7	V
V _I	Enable input voltage ⁽²⁾	-0.5	7	V
V _{I/O}	I ² C bus voltage ⁽²⁾	-0.5	7	V
I _{IK}	Input clamp current	V _I < 0	-50	mA
I _{OK}	Output clamp current	V _O < 0	-50	mA
I _O	Continuous output current		±50	mA
	Continuous current through V _{CC} or GND		±100	mA
T _{stg}	Storage temperature	-65	150	°C

- (1) Stresses beyond those listed under *Absolute Maximum Ratings* may cause permanent damage to the device. These are stress ratings only, which do not imply functional operation of the device at these or any other conditions beyond those indicated under *Recommended Operating Conditions*. Exposure to absolute-maximum-rated conditions for extended periods may affect device reliability.
- (2) The input negative-voltage and output voltage ratings may be exceeded if the input and output current ratings are observed.

6.2 ESD Ratings

		VALUE	UNIT
V _(ESD)	Electrostatic discharge	Human-body model (HBM), per ANSI/ESDA/JEDEC JS-001 ⁽¹⁾	±2000
		Charged-device model (CDM), per JEDEC specification JESD22-C101 ⁽²⁾	±1000

- (1) JEDEC document JEP155 states that 500-V HBM allows safe manufacturing with a standard ESD control process.
- (2) JEDEC document JEP157 states that 250-V CDM allows safe manufacturing with a standard ESD control process.

6.3 Recommended Operating Conditions

		MIN	MAX	UNIT
V _{CC}	Supply voltage	2.3	3.6	V
V _{IH}	High-level input voltage	SDA and SCL inputs	0.7 × V _{CC}	5.5
		EN input	2	5.5
V _{IL} ⁽¹⁾	Low-level input voltage	SDA and SCL inputs	-0.5	0.3 × V _{CC}
		EN input	-0.5	0.8
V _{ILc} ⁽¹⁾	SDA and SCL low-level input voltage contention	-0.5	0.4	V
I _{OL}	Low-level output current	V _{CC} = 2.3 V		6
		V _{CC} = 3 V		6
T _A	Operating free-air temperature	-40	85	°C

- (1) V_{IL} specification is for the EN input and the first low level seen by the SDAx and SCLx lines. V_{ILc} is for the second and subsequent low levels seen by the SDAx and SCLx lines. V_{ILc} must be at least 70 mV below V_{OL}.

6.4 Thermal Information

THERMAL METRIC ⁽¹⁾	PCA9515B	UNIT	
	DGK (VSSOP)		
	8 PINS		
R _{θJA}	Junction-to-ambient thermal resistance ⁽²⁾	170.8	°C/W
R _{θJC(top)}	Junction-to-case (top) thermal resistance	62.9	°C/W
R _{θJB}	Junction-to-board thermal resistance	91.6	°C/W
ψ _{JT}	Junction-to-top characterization parameter	9.5	°C/W
ψ _{JB}	Junction-to-board characterization parameter	90.2	°C/W

- (1) For more information about traditional and new thermal metrics, see the *Semiconductor and IC Package Thermal Metrics* application report, [SPRA953](#).
- (2) The package thermal impedance is calculated in accordance with JESD 51-7.

6.5 Electrical Characteristics

over recommended operating free-air temperature range (unless otherwise noted)

PARAMETER		TEST CONDITIONS		V _{CC}	MIN	TYP ⁽¹⁾	MAX	UNIT
V _{IK}	Input diode clamp voltage	I _I = -18 mA		2.3 V to 3.6 V	-1.2			V
V _{OL}	Low-level output voltage	SDAx, SCLx	I _{OL} = 20 μA or 6 mA	2.3 V to 3.6 V	0.47	0.52	0.6	V
V _{OL} - V _{ILc}	Low-level input voltage below low-level output voltage	SDAx, SCLx	guaranteed by design	2.3 V to 3.6 V	120			mV
I _{CC}	Quiescent supply current	Both channels high, SDAx = SCLx = V _{CC}		2.7 V	0.5	3	mA	
				3.6 V	0.5	3		
		Both channels low, SDA0 = SCL0 = GND and SDA1 = SCL1 = open; or SDA0 = SCL0 = open and SDA1 = SCL1 = GND		2.7 V	1	4		
				3.6 V	1	4		
In contention, SDAx = SCLx = GND		2.7 V	1	4				
		3.6 V	1	4				
I _I	Input current	SDAx, SCLx	V _I = 3.6 V	2.3 V to 3.6 V	±1			μA
			V _I = 0.2 V		3			
		EN	V _I = V _{CC}		±1			
			V _I = 0.2 V		-10	-20		
I _{off}	Leakage current	SDAx, SCLx	V _I = 3.6 V	0 V	0.5			μA
			V _I = GND		0.5			
I _{I(ramp)}	Leakage current during power up	SDAx, SCLx	V _I = 3.6 V	0 V to 2.3 V	1			μA
C _{in}	Input capacitance	EN	V _I = 3 V or GND	EN = H	3.3 V	7	9	pF
		SDAx, SCLx			3.3 V	7	9	

(1) All typical values are at nominal supply voltage (V_{CC} = 2.5 V or 3.3 V) and T_A = 25°C.

6.6 Timing Requirements

over recommended operating free-air temperature range (unless otherwise noted) (see [Figure 3](#))

		V _{CC}	MIN	MAX	UNIT
t _{su}	Setup time, EN↑ before Start condition	2.5 V ± 0.2 V	100		ns
		3.3 V ± 0.3 V	100		
t _h	Hold time, EN↓ after Stop condition	2.5 V ± 0.2 V	130		ns
		3.3 V ± 0.3 V	100		

6.7 Switching Characteristics

over recommended operating free-air temperature range, C_L ≤ 100 pF (unless otherwise noted)

PARAMETER		FROM (INPUT)	TO (OUTPUT)	V _{CC}	MIN	TYP ⁽¹⁾	MAX	UNIT
t _{PZL}	Propagation delay time ⁽²⁾	SDA0, SCL0 or SDA1, SCL1	SDA1, SCL1 or SDA0, SCL0	2.5 V ± 0.2 V	45	82	130	ns
				3.3 V ± 0.3 V	45	68	120	
t _{PLZ}				2.5 V ± 0.2 V	33	113	190	
				3.3 V ± 0.3 V	33	102	180	
t _{tHL}	Output transition time ⁽²⁾ (SDAx, SCLx)	80%	20%	2.5 V ± 0.2 V	57			ns
				3.3 V ± 0.3 V	58			
t _{tLH}		20%	80%	2.5 V ± 0.2 V	148			
				3.3 V ± 0.3 V	147			

(1) All typical values are at nominal supply voltage (V_{CC} = 2.5 V or 3.3 V) and T_A = 25°C.

(2) Different load resistance and capacitance alter the RC time constant, thereby changing the propagation delay and transition times.

6.8 Typical Characteristics

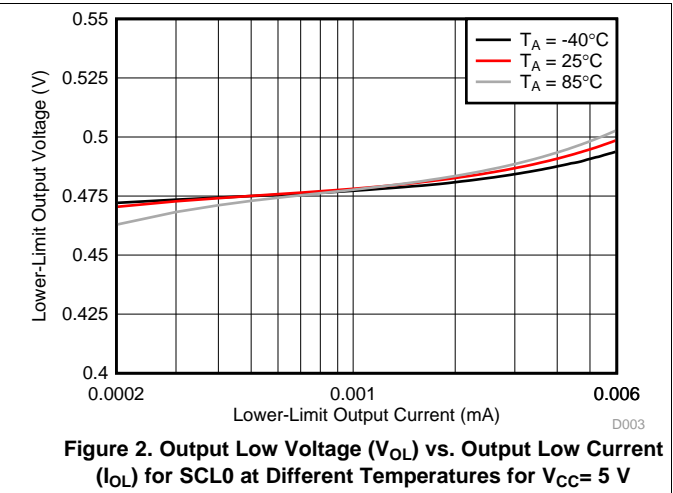
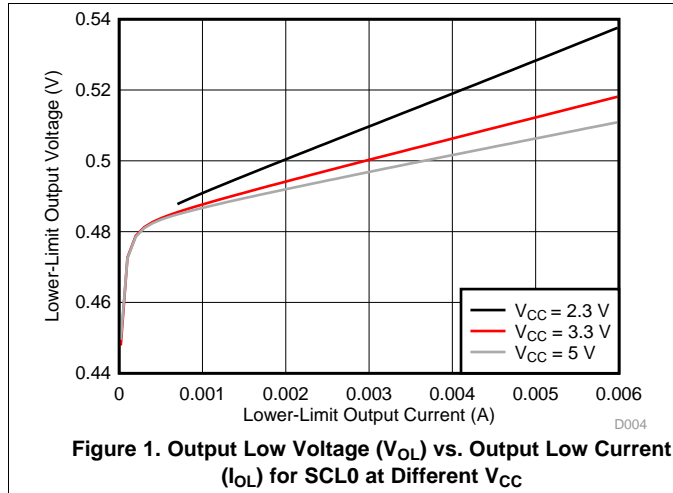

7 Parameter Measurement Information

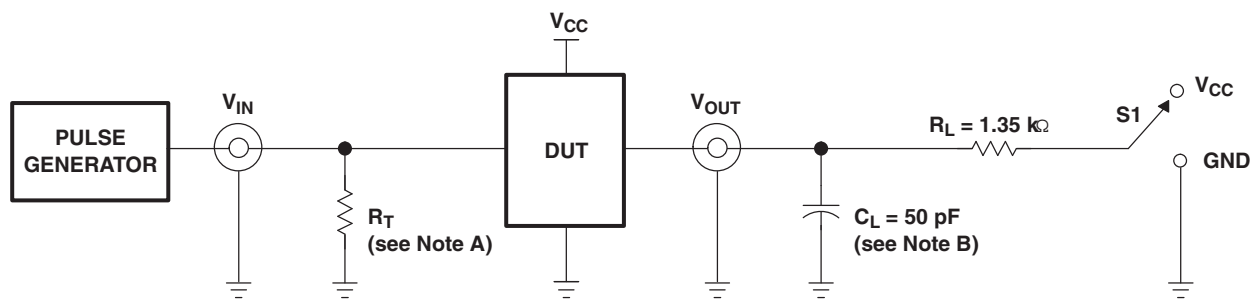

TEST	S1
t_{PLZ}/t_{pZL}	V_{CC}

TEST CIRCUIT FOR OPEN-DRAIN OUTPUT

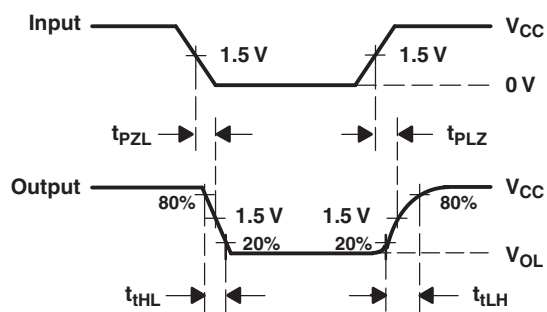

VOLTAGE WAVEFORMS
PROPAGATION DELAY AND OUTPUT TRANSITION TIMES

- A. R_T termination resistance should be equal to Z_{OUT} of pulse generators.
- B. C_L includes probe and jig capacitance.
- C. All input pulses are supplied by generators having the following characteristics: $PRR \leq 10$ MHz, $Z_O = 50 \Omega$, slew rate ≥ 1 V/ns.
- D. The outputs are measured one at a time, with one transition per measurement.

Figure 3. Test Circuit and Voltage Waveforms

8 Detailed Description

8.1 Overview

The PCA9515B is a BiCMOS dual bidirectional buffer integrated circuit intended for I²C bus and SMBus applications. The device contains two identical bidirectional open-drain buffer circuits that enables I²C and similar bus systems to be extended without degrading system performance. This device enables I²C and similar bus systems to be extended (and add more slaves) without degradation of performance. The dual bidirectional I²C buffer is operational at 2.3 V to 3.6 V V_{CC}.

The PCA9515B buffers both the serial data (SDA) and serial clock (SCL) signals on the I²C bus, while retaining all the operating modes and features of the I²C system. The device allows two buses, of 400-pF bus capacitance, to be connected in an I²C application.

The I²C bus capacitance limit of 400 pF restricts the number of slave devices and bus length. Using the PCA9515B, a system designer can capacitively isolate two halves of a bus, thus accommodating more I²C devices and longer trace lengths.

The PCA9515B has an active-high enable (EN) input with an internal pull-up. This allows users to select when the repeater is active and isolate malfunctioning slaves on power-up reset. States should never be changed during an I²C operation. Disabling during a bus operation will hang the bus and enabling part way through a bus cycle may confuse the I²C parts being enabled. The EN input should only change state when the global bus and the repeater port are in an idle state to prevent system failures.

The PCA9515B can also be used to operate two buses, one at 5 V interface levels and the other at 3.3 V interface levels. The buses may also function at 400-kHz or 100-kHz operating frequency. If the two buses are operating at different frequencies, the 100-kHz bus must be isolated if the operation of the 400-kHz bus is required. If the master is running at 400-kHz, the maximum system operating frequency may be less than 400 kHz because of the delays added by the repeater.

The low level outputs for each internal buffer are approximately 0.5 V; however, the input voltage of each internal buffer must be 70 mV or more below the low level output when the output is driven low internally. This prevents a lockup condition from occurring when the input low condition is released.

Two or more PCA9515B devices cannot be used in series. Since there is no direction pin, different valid low-voltage levels are used to avoid lockup conditions between the input and the output of each repeater. A valid low, applied at the input of a PCA9515B, is propagated as a buffered low with a higher value on the enabled outputs. When this buffered low is applied to another PCA9515B-type device in series, the second device does not recognize it as a valid low and does not propagate it as a buffered low.

The device contains a power-up control circuit that sets an internal latch to prevent the output circuits from becoming active until V_{CC} is at a valid level (V_{CC} = 2.3 V).

As with the standard I²C system, pullup resistors are required to provide the logic high levels on the buffered bus. The PCA9515B has standard open-collector configuration of the I²C bus. The size of the pullup resistors depend on the system; however, each side of the repeater must have a pullup resistor. The device is designed to work with Standard Mode and Fast Mode I²C devices in addition to SMBus devices. Standard Mode I²C devices only specify a 3 mA termination current in a generic I²C system where Standard Mode devices and multiple masters are possible. Under certain conditions, high termination currents can be used.

8.2 Functional Block Diagram

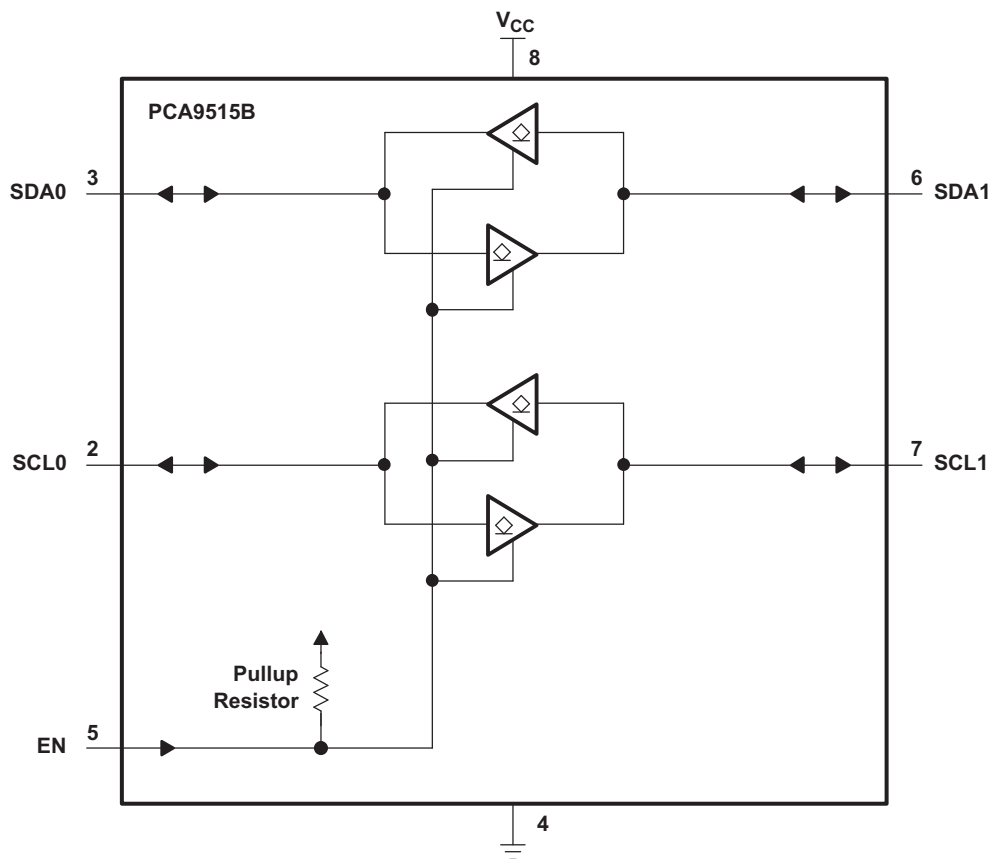

Figure 4. Logic Diagram (Positive Logic)

8.3 Feature Description

8.3.1 Two-Channel Bidirectional Buffer

The PCA9515B is a two-channel bidirectional buffer for open-drain applications like I²C and SMBus.

8.3.2 Bidirectional Voltage-Level Translation

The PCA9515B allows bidirectional voltage-level translation (up-translation and down-translation) between low voltages (down to 2.3 V) and higher voltages (up to 5.5 V).

8.3.3 Active-High Enable Input

The PCA9515B has an active-high enable (EN) input with an internal pull-up to V_{CC}. The enable input needs to be pulled to GND to disable the PCA9515B and isolate the I²C buses. Pulling-up the enable pin or floating the enable pin causes the PCA9515B to turn on and buffer the I²C bus.

8.4 Device Functional Modes

The PCA9515B has an active-high enable (EN) input with an internal pull-up to V_{CC} , which allows the user to select when the repeater is active. This can be used to isolate a badly behaved slave on power-up reset. It should never change state during an I²C operation, because disabling during a bus operation may hang the bus, and enabling part way through the bus cycles could confuse the I²C parts being enabled. The EN input should only change state when the global bus and repeater port are in the idle state to prevent system failures. [Table 1](#) lists the PCA9515B functions.

Table 1. Function Table

INPUT EN	FUNCTION
L	Outputs disabled
H	SDA0 = SDA1, SCL0 = SCL1

9 Application and Implementation

NOTE

Information in the following applications sections is not part of the TI component specification, and TI does not warrant its accuracy or completeness. TI's customers are responsible for determining suitability of components for their purposes. Customers should validate and test their design implementation to confirm system functionality.

9.1 Application Information

The PCA9515B is typically used to buffer an I²C signal, isolating capacitance from two sides of the bus. This allows for longer traces and cables, and a more robust I²C communication. *Typical Application* section describes how the PCA9515B may be used to isolate a standard mode and fast mode I²C bus, to allow for faster communications when required, but maintaining compatibility with the slower standard mode slave device.

It is critical to keep the V_{OL} and V_{IL} requirements in mind when designing with buffers, especially when using multiple buffers/translators on the same node. Care must be taken to not violate the V_{IL} requirement of a buffer, otherwise I²C communication errors will occur. An example of this would be a buffer with a V_{OL} of ~ 0.5 V, and a device requires a V_{IL} of less than 0.4 V. Such a connection would result in the slave device being unable to recognize the output low signal as a valid low.

9.2 Typical Application

A typical application is shown in [Figure 5](#). In this example, the system master is running on a 3.3 V I²C bus, while the slave is connected to a 5-V bus. Both buses run at 100 kHz, unless the slave bus is isolated. If the slave bus is isolated (by pulling the EN pin low), the master bus can run at 400 kHz. Master devices can be placed on either bus, the PCA9515B does not care which side the master is on. Decoupling capacitors are required, but are not shown in [Figure 5](#) for simplicity.

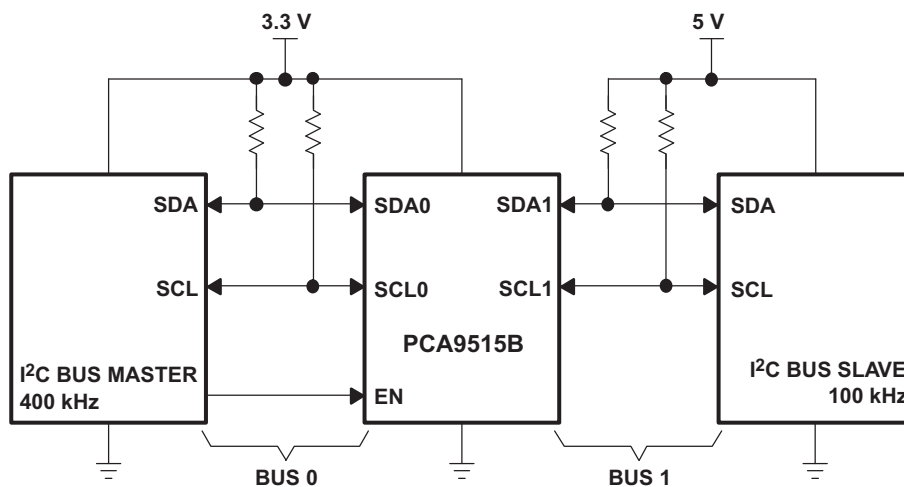

Figure 5. Typical Application

9.2.1 Design Requirements

[Table 2](#) lists the design requirements.

Table 2. Design Requirements

PARAMETER	VALUE
Input-side I ² C signal	3.3 V
Output-side I ² C signal	5 V

9.2.2 Detailed Design Procedure

The PCA9515B is 5.5 V tolerant, so it does not require any additional circuitry to translate between the different bus voltages. When one side of the PCA9515B is pulled low by a device on the I²C bus, a CMOS hysteresis-type input detects the falling edge and causes an internal driver on the other side to turn on, thus causing the other side also to go low. The side driven low by the PCA9515B typically is at $V_{OL} = 0.5$ V.

Figure 6 and Figure 7 show the waveforms that are seen in a typical application. If the bus master in Figure 5 writes to the slave through the PCA9515B, Bus 0 has the waveform shown in Figure 6. The waveform looks like a normal I²C transmission until the falling edge of the eighth clock pulse. At that point, the master releases the data line (SDA) while the slave pulls it low through the PCA9515B. Because the V_{OL} of the PCA9515B typically is around 0.5 V, a step in the SDA is seen. After the master has transmitted the ninth clock pulse, the slave releases the data line.

On the Bus 1 side of the PCA9515B, the clock and data lines have a positive offset from ground equal to the V_{OL} of the PCA9515B. After the eighth clock pulse, the data line is pulled to the V_{OL} of the slave device, which is very close to ground in the example.

9.2.3 Application Curves

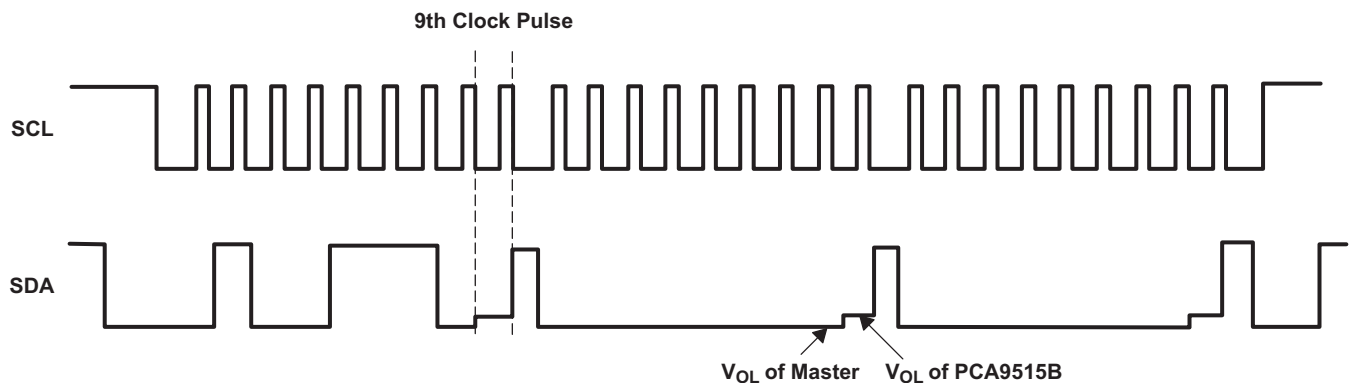

Figure 6. Bus 0 Waveforms

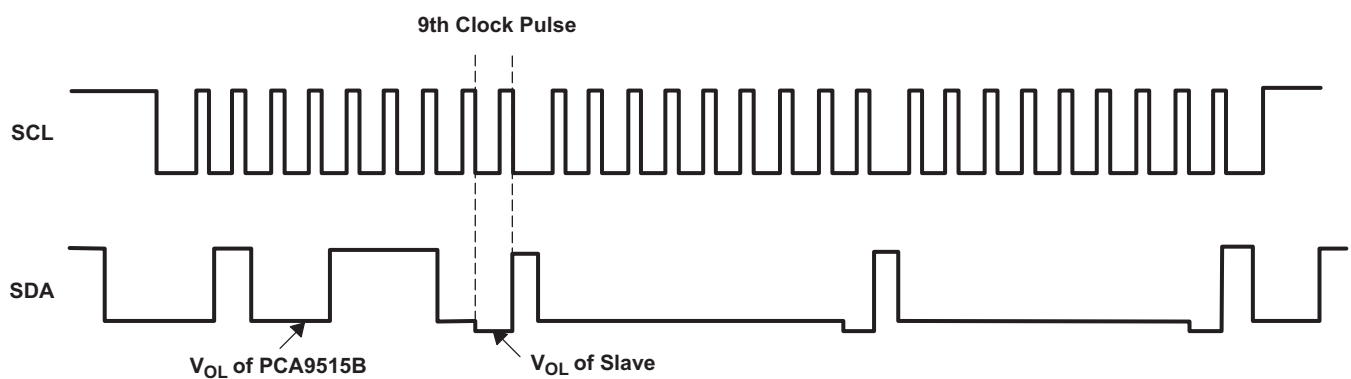

Figure 7. Bus 1 Waveforms

10 Power Supply Recommendations

For V_{CC} , a 2.3 V to 3.6 V power supply is required. Standard decoupling capacitors are recommended. These capacitors typically range from 0.1 μ F to 1 μ F, but the ideal capacitance depends on the amount of noise from the power supply.

11 Layout

11.1 Layout Guidelines

For printed circuit board (PCB) layout of the PCA9515B, common PCB layout practices should be followed. In all PCB layouts, it is a best practice to avoid right angles in signal traces, to fan out signal traces away from each other upon leaving the vicinity of an integrated circuit (IC), and to use thicker trace widths to carry higher amounts of current that commonly pass through power and ground traces. By-pass and de-coupling capacitors are commonly used to control the voltage on the V_{CC} pin, using a larger capacitor to provide additional power in the event of a short power supply glitch and a small capacitor to filter out high-frequency ripple. These decoupling capacitors should be placed as close to the V_{CC} pin of PCA9515B as possible.

The layout example shown in Figure 8 shows a 4 layer board, which is preferable for boards with higher density signal routing. On a 4 layer PCB, it is common to route signals on the top and bottom layer, dedicate one internal layer to a ground plane, and one to power plane. In a board layout using planes or split planes for power and ground, vias are placed directly next to the surface mount component pad which needs to attach to V_{CC} or GND and the via is connected electrically to the internal layer on the other side of the board. Vias are also used when a signal trace needs to be routed to the opposite side of the board. This routing and via is not necessary if V_{CC} and GND are both full planes as opposed to the partial planes depicted.

11.2 Layout Example

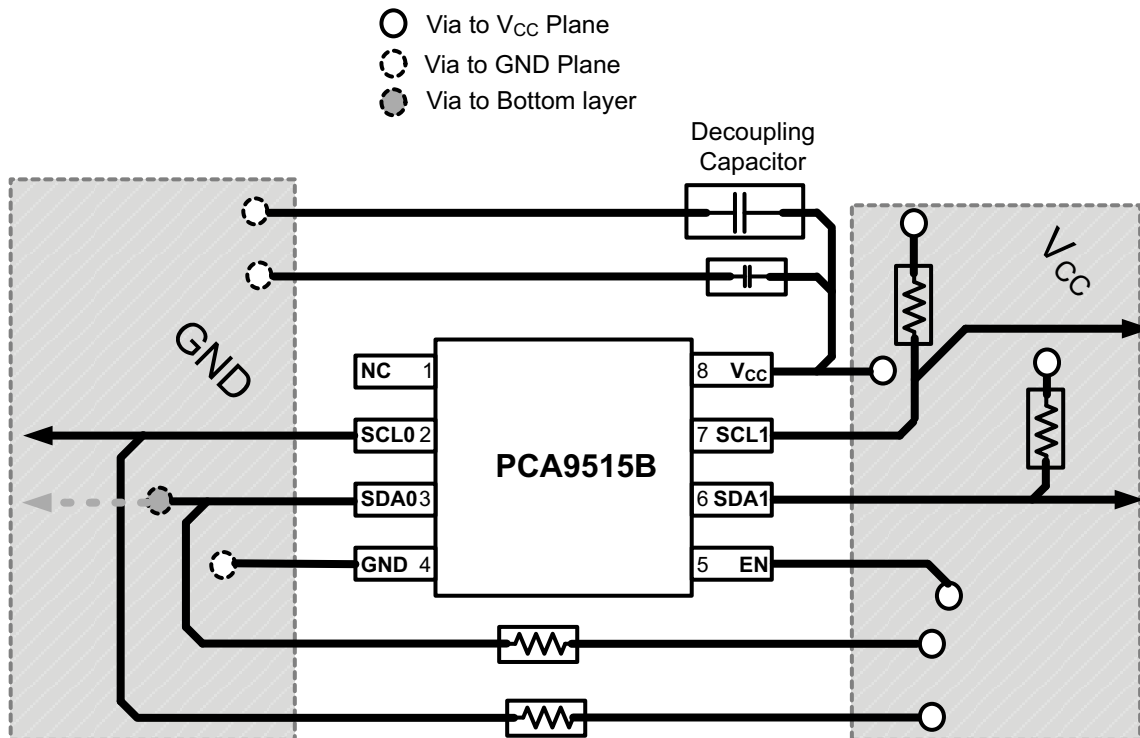

Figure 8. Layout Schematic

12 Device and Documentation Support

12.1 Documentation Support

12.1.1 Related Documentation

For related documentation see the following:

- *I2C Bus Pullup Resistor Calculation*, [SLVA689](#)
- *Maximum Clock Frequency of I2C Bus Using Repeaters*, [SLVA695](#)
- *Introduction to Logic*, [SLVA700](#)
- *Understanding the I2C Bus*, [SLVA704](#)

12.2 Community Resources

The following links connect to TI community resources. Linked contents are provided "AS IS" by the respective contributors. They do not constitute TI specifications and do not necessarily reflect TI's views; see TI's [Terms of Use](#).

TI E2E™ Online Community *TI's Engineer-to-Engineer (E2E) Community*. Created to foster collaboration among engineers. At [e2e.ti.com](#), you can ask questions, share knowledge, explore ideas and help solve problems with fellow engineers.

Design Support *TI's Design Support* Quickly find helpful E2E forums along with design support tools and contact information for technical support.

12.3 Trademarks

E2E is a trademark of Texas Instruments.
All other trademarks are the property of their respective owners.

12.4 Electrostatic Discharge Caution



This integrated circuit can be damaged by ESD. Texas Instruments recommends that all integrated circuits be handled with appropriate precautions. Failure to observe proper handling and installation procedures can cause damage.

ESD damage can range from subtle performance degradation to complete device failure. Precision integrated circuits may be more susceptible to damage because very small parametric changes could cause the device not to meet its published specifications.

12.5 Glossary

[SLYZ022](#) — *TI Glossary*.

This glossary lists and explains terms, acronyms, and definitions.

13 Mechanical, Packaging, and Orderable Information

The following pages include mechanical, packaging, and orderable information. This information is the most current data available for the designated devices. This data is subject to change without notice and revision of this document. For browser-based versions of this data sheet, refer to the left-hand navigation.

PACKAGING INFORMATION

Orderable Device	Status (1)	Package Type	Package Drawing	Pins	Package Qty	Eco Plan (2)	Lead/Ball Finish (6)	MSL Peak Temp (3)	Op Temp (°C)	Device Marking (4/5)	Samples
PCA9515BDGKR	ACTIVE	VSSOP	DGK	8	2500	Green (RoHS & no Sb/Br)	CU NIPDAU CU NIPDAUAG	Level-1-260C-UNLIM	-40 to 85	(7SE ~ 7SF)	Samples

(1) The marketing status values are defined as follows:

ACTIVE: Product device recommended for new designs.

LIFEBUY: TI has announced that the device will be discontinued, and a lifetime-buy period is in effect.

NRND: Not recommended for new designs. Device is in production to support existing customers, but TI does not recommend using this part in a new design.

PREVIEW: Device has been announced but is not in production. Samples may or may not be available.

OBSELETE: TI has discontinued the production of the device.

(2) Eco Plan - The planned eco-friendly classification: Pb-Free (RoHS), Pb-Free (RoHS Exempt), or Green (RoHS & no Sb/Br) - please check <http://www.ti.com/productcontent> for the latest availability information and additional product content details.

TBD: The Pb-Free/Green conversion plan has not been defined.

Pb-Free (RoHS): TI's terms "Lead-Free" or "Pb-Free" mean semiconductor products that are compatible with the current RoHS requirements for all 6 substances, including the requirement that lead not exceed 0.1% by weight in homogeneous materials. Where designed to be soldered at high temperatures, TI Pb-Free products are suitable for use in specified lead-free processes.

Pb-Free (RoHS Exempt): This component has a RoHS exemption for either 1) lead-based flip-chip solder bumps used between the die and package, or 2) lead-based die adhesive used between the die and leadframe. The component is otherwise considered Pb-Free (RoHS compatible) as defined above.

Green (RoHS & no Sb/Br): TI defines "Green" to mean Pb-Free (RoHS compatible), and free of Bromine (Br) and Antimony (Sb) based flame retardants (Br or Sb do not exceed 0.1% by weight in homogeneous material)

(3) MSL, Peak Temp. - The Moisture Sensitivity Level rating according to the JEDEC industry standard classifications, and peak solder temperature.

(4) There may be additional marking, which relates to the logo, the lot trace code information, or the environmental category on the device.

(5) Multiple Device Markings will be inside parentheses. Only one Device Marking contained in parentheses and separated by a "~" will appear on a device. If a line is indented then it is a continuation of the previous line and the two combined represent the entire Device Marking for that device.

(6) Lead/Ball Finish - Orderable Devices may have multiple material finish options. Finish options are separated by a vertical ruled line. Lead/Ball Finish values may wrap to two lines if the finish value exceeds the maximum column width.

Important Information and Disclaimer: The information provided on this page represents TI's knowledge and belief as of the date that it is provided. TI bases its knowledge and belief on information provided by third parties, and makes no representation or warranty as to the accuracy of such information. Efforts are underway to better integrate information from third parties. TI has taken and continues to take reasonable steps to provide representative and accurate information but may not have conducted destructive testing or chemical analysis on incoming materials and chemicals. TI and TI suppliers consider certain information to be proprietary, and thus CAS numbers and other limited information may not be available for release.

In no event shall TI's liability arising out of such information exceed the total purchase price of the TI part(s) at issue in this document sold by TI to Customer on an annual basis.

TAPE AND REEL INFORMATION

QUADRANT ASSIGNMENTS FOR PIN 1 ORIENTATION IN TAPE

*All dimensions are nominal

Device	Package Type	Package Drawing	Pins	SPQ	Reel Diameter (mm)	Reel Width W1 (mm)	A0 (mm)	B0 (mm)	K0 (mm)	P1 (mm)	W (mm)	Pin1 Quadrant
PCA9515BDGKR	VSSOP	DGK	8	2500	330.0	12.4	5.3	3.4	1.4	8.0	12.0	Q1
PCA9515BDGKR	VSSOP	DGK	8	2500	330.0	12.4	5.3	3.3	1.3	8.0	12.0	Q1

TAPE AND REEL BOX DIMENSIONS

*All dimensions are nominal

Device	Package Type	Package Drawing	Pins	SPQ	Length (mm)	Width (mm)	Height (mm)
PCA9515BDGKR	VSSOP	DGK	8	2500	364.0	364.0	27.0
PCA9515BDGKR	VSSOP	DGK	8	2500	346.0	346.0	35.0



- NOTES:
- A. All linear dimensions are in millimeters.
 - B. This drawing is subject to change without notice.
 - C. Publication IPC-7351 is recommended for alternate designs.
 - D. Laser cutting apertures with trapezoidal walls and also rounding corners will offer better paste release. Customers should contact their board assembly site for stencil design recommendations. Refer to IPC-7525 for other stencil recommendations.
 - E. Customers should contact their board fabrication site for solder mask tolerances between and around signal pads.

IMPORTANT NOTICE AND DISCLAIMER

TI PROVIDES TECHNICAL AND RELIABILITY DATA (INCLUDING DATASHEETS), DESIGN RESOURCES (INCLUDING REFERENCE DESIGNS), APPLICATION OR OTHER DESIGN ADVICE, WEB TOOLS, SAFETY INFORMATION, AND OTHER RESOURCES "AS IS" AND WITH ALL FAULTS, AND DISCLAIMS ALL WARRANTIES, EXPRESS AND IMPLIED, INCLUDING WITHOUT LIMITATION ANY IMPLIED WARRANTIES OF MERCHANTABILITY, FITNESS FOR A PARTICULAR PURPOSE OR NON-INFRINGEMENT OF THIRD PARTY INTELLECTUAL PROPERTY RIGHTS.

These resources are intended for skilled developers designing with TI products. You are solely responsible for (1) selecting the appropriate TI products for your application, (2) designing, validating and testing your application, and (3) ensuring your application meets applicable standards, and any other safety, security, or other requirements. These resources are subject to change without notice. TI grants you permission to use these resources only for development of an application that uses the TI products described in the resource. Other reproduction and display of these resources is prohibited. No license is granted to any other TI intellectual property right or to any third party intellectual property right. TI disclaims responsibility for, and you will fully indemnify TI and its representatives against, any claims, damages, costs, losses, and liabilities arising out of your use of these resources.

TI's products are provided subject to TI's Terms of Sale (www.ti.com/legal/termsofsale.html) or other applicable terms available either on ti.com or provided in conjunction with such TI products. TI's provision of these resources does not expand or otherwise alter TI's applicable warranties or warranty disclaimers for TI products.

Mailing Address: Texas Instruments, Post Office Box 655303, Dallas, Texas 75265
Copyright © 2019, Texas Instruments Incorporated

Looking for pricing, stock, or lifecycle information?

Click below to explore more details on WIN SOURCE:

 [View PCA9515BDGKR on WIN SOURCE](#)

 [Texas Instruments](#) Information

Optimize Your Supply Chain with WIN SOURCE Solutions

-  Global Sourcing Solution
-  Obsolete Management
-  Cost Control Management
-  Shortage Management
-  Alternative Solution
-  Excess Inventory Management