



**THE DATASHEET OF  
PCI6420GHK**



# **PCI6620/PCI6420**

**Dual Socket CardBus and Smart Card Controller  
With Dedicated SD/MS-Pro Sockets**

## *Data Manual*

## IMPORTANT NOTICE

Texas Instruments Incorporated and its subsidiaries (TI) reserve the right to make corrections, modifications, enhancements, improvements, and other changes to its products and services at any time and to discontinue any product or service without notice. Customers should obtain the latest relevant information before placing orders and should verify that such information is current and complete. All products are sold subject to TI's terms and conditions of sale supplied at the time of order acknowledgment.

TI warrants performance of its hardware products to the specifications applicable at the time of sale in accordance with TI's standard warranty. Testing and other quality control techniques are used to the extent TI deems necessary to support this warranty. Except where mandated by government requirements, testing of all parameters of each product is not necessarily performed.

TI assumes no liability for applications assistance or customer product design. Customers are responsible for their products and applications using TI components. To minimize the risks associated with customer products and applications, customers should provide adequate design and operating safeguards.

TI does not warrant or represent that any license, either express or implied, is granted under any TI patent right, copyright, mask work right, or other TI intellectual property right relating to any combination, machine, or process in which TI products or services are used. Information published by TI regarding third-party products or services does not constitute a license from TI to use such products or services or a warranty or endorsement thereof. Use of such information may require a license from a third party under the patents or other intellectual property of the third party, or a license from TI under the patents or other intellectual property of TI.

Reproduction of information in TI data books or data sheets is permissible only if reproduction is without alteration and is accompanied by all associated warranties, conditions, limitations, and notices. Reproduction of this information with alteration is an unfair and deceptive business practice. TI is not responsible or liable for such altered documentation.

Resale of TI products or services with statements different from or beyond the parameters stated by TI for that product or service voids all express and any implied warranties for the associated TI product or service and is an unfair and deceptive business practice. TI is not responsible or liable for any such statements.

Following are URLs where you can obtain information on other Texas Instruments products and application solutions:

| <b>Products</b>  |  | <b>Applications</b> |  |
|------------------|--|---------------------|--|
| Amplifiers       | <a href="http://amplifier.ti.com">amplifier.ti.com</a>             | Audio               | <a href="http://www.ti.com/audio">www.ti.com/audio</a>                   |
| Data Converters  | <a href="http://dataconverter.ti.com">dataconverter.ti.com</a>     | Automotive          | <a href="http://www.ti.com/automotive">www.ti.com/automotive</a>         |
| DSP              | <a href="http://dsp.ti.com">dsp.ti.com</a>                         | Broadband           | <a href="http://www.ti.com/broadband">www.ti.com/broadband</a>           |
| Interface        | <a href="http://interface.ti.com">interface.ti.com</a>             | Digital Control     | <a href="http://www.ti.com/digitalcontrol">www.ti.com/digitalcontrol</a> |
| Logic            | <a href="http://logic.ti.com">logic.ti.com</a>                     | Military            | <a href="http://www.ti.com/military">www.ti.com/military</a>             |
| Power Mgmt       | <a href="http://power.ti.com">power.ti.com</a>                     | Optical Networking  | <a href="http://www.ti.com/opticalnetwork">www.ti.com/opticalnetwork</a> |
| Microcontrollers | <a href="http://microcontroller.ti.com">microcontroller.ti.com</a> | Security            | <a href="http://www.ti.com/security">www.ti.com/security</a>             |
|                  |  | Telephony           | <a href="http://www.ti.com/telephony">www.ti.com/telephony</a>           |
|                  |  | Video & Imaging     | <a href="http://www.ti.com/video">www.ti.com/video</a>                   |
|                  |  | Wireless            | <a href="http://www.ti.com/wireless">www.ti.com/wireless</a>             |

Mailing Address: Texas Instruments  
Post Office Box 655303 Dallas, Texas 75265

# Contents

| <i>Section</i> | <i>Title</i>   | <i>Page</i> |
|----------------|--|-------------|
| <b>1</b>       | <b>Introduction</b>                                  | <b>1-1</b>  |
| 1.1            | Description  | 1-1         |
| 1.2            | Features   | 1-2         |
| 1.3            | Related Documents                                    | 1-2         |
| 1.4            | Trademarks   | 1-3         |
| 1.5            | Terms and Definitions                                | 1-4         |
| 1.6            | Ordering Information                                 | 1-4         |
| <b>2</b>       | <b>Terminal Descriptions</b>                         | <b>2-1</b>  |
| <b>3</b>       | <b>Feature/Protocol Descriptions</b>                 | <b>3-1</b>  |
| 3.1            | Power Supply Sequencing                              | 3-2         |
| 3.2            | I/O Characteristics                                  | 3-2         |
| 3.3            | Clamping Voltages                                    | 3-2         |
| 3.4            | Peripheral Component Interconnect (PCI) Interface    | 3-2         |
| 3.4.1          | Device Resets  | 3-3         |
| 3.4.2          | PCI Bus Lock ( $\overline{\text{LOCK}}$ )            | 3-3         |
| 3.4.3          | Serial EEPROM I <sup>2</sup> C Bus                   | 3-3         |
| 3.4.4          | Functions 0 and 1 (CardBus) Subsystem Identification | 3-4         |
| 3.4.5          | Function 3 (Flash Media) Subsystem Identification    | 3-5         |
| 3.5            | Summary of UltraMedia™ Cards                         | 3-5         |
| 3.5.1          | MultiMediaCard (MMC)                                 | 3-5         |
| 3.5.2          | Secure Digital (SD)                                  | 3-5         |
| 3.5.3          | Memory Stick/MS-Pro                                  | 3-5         |
| 3.5.4          | Smart Card   | 3-6         |
| 3.6            | PC Card Applications                                 | 3-6         |
| 3.6.1          | PC Card Insertion/Removal and Recognition            | 3-6         |
| 3.6.2          | Low Voltage CardBus Card Detection                   | 3-6         |
| 3.6.3          | UltraMedia Card Detection                            | 3-6         |
| 3.6.4          | Flash Media Card Detection                           | 3-7         |
| 3.6.5          | Power Switch Interface                               | 3-8         |
| 3.6.6          | Internal Ring Oscillator                             | 3-9         |
| 3.6.7          | Integrated Pullup Resistors for PC Card Interface    | 3-9         |
| 3.6.8          | SPKROUT and CAUDPWM Usage                            | 3-9         |
| 3.6.9          | LED Socket Activity Indicators                       | 3-9         |
| 3.6.10         | CardBus Socket Registers                             | 3-10        |
| 3.6.11         | 48-MHz Clock Requirements                            | 3-10        |
| 3.7            | Serial EEPROM Interface                              | 3-11        |
| 3.7.1          | Serial-Bus Interface Implementation                  | 3-11        |

|          |   |            |
|----------|---|------------|
| 3.7.2    | Accessing Serial-Bus Devices Through Software                                     | 3–11       |
| 3.7.3    | Serial-Bus Interface Protocol   | 3–11       |
| 3.7.4    | Serial-Bus EEPROM Application   | 3–13       |
| 3.8      | Programmable Interrupt Subsystem  | 3–15       |
| 3.8.1    | PC Card Functional and Card Status Change Interrupts                              | 3–16       |
| 3.8.2    | Interrupt Masks and Flags   | 3–17       |
| 3.8.3    | Using Parallel IRQ Interrupts   | 3–18       |
| 3.8.4    | Using Parallel PCI Interrupts   | 3–18       |
| 3.8.5    | Using Serialized IRQSER Interrupts  | 3–19       |
| 3.8.6    | SMI Support in the PCI16x20 Device  | 3–19       |
| 3.9      | Power Management Overview   | 3–19       |
| 3.9.1    | Integrated Low-Dropout Voltage Regulator (LDO-VR)                                 | 3–20       |
| 3.9.2    | CardBus (Functions 0 and 1) Clock Run Protocol                                    | 3–20       |
| 3.9.3    | CardBus PC Card Power Management  | 3–21       |
| 3.9.4    | 16-Bit PC Card Power Management   | 3–21       |
| 3.9.5    | Suspend Mode  | 3–21       |
| 3.9.6    | Requirements for Suspend Mode   | 3–22       |
| 3.9.7    | Ring Indicate   | 3–22       |
| 3.9.8    | PCI Power Management  | 3–23       |
| 3.9.8.1  | CardBus Power Management<br>(Functions 0 and 1)                                   | 3–23       |
| 3.9.8.2  | Flash Media (Function 3) Power Management   | 3–24       |
| 3.9.9    | CardBus Bridge Power Management   | 3–24       |
| 3.9.10   | ACPI Support  | 3–25       |
| 3.9.11   | Master List of $\overline{\text{PME}}$ Context Bits and Global Reset-Only<br>Bits | 3–25       |
| <b>4</b> | <b>PC Card Controller Programming Model</b>                                       | <b>4–1</b> |
| 4.1      | PCI Configuration Register Map (Functions 0 and 1)                                | 4–1        |
| 4.2      | Vendor ID Register  | 4–2        |
| 4.3      | Device ID Register Functions 0 and 1  | 4–3        |
| 4.4      | Command Register  | 4–4        |
| 4.5      | Status Register   | 4–5        |
| 4.6      | Revision ID Register  | 4–6        |
| 4.7      | Class Code Register   | 4–6        |
| 4.8      | Cache Line Size Register  | 4–6        |
| 4.9      | Latency Timer Register  | 4–7        |
| 4.10     | Header Type Register  | 4–7        |
| 4.11     | BIST Register   | 4–7        |
| 4.12     | CardBus Socket Registers/ExCA Base Address Register                               | 4–8        |
| 4.13     | Capability Pointer Register   | 4–8        |
| 4.14     | Secondary Status Register   | 4–9        |
| 4.15     | PCI Bus Number Register   | 4–10       |
| 4.16     | CardBus Bus Number Register   | 4–10       |
| 4.17     | Subordinate Bus Number Register   | 4–10       |

|          |  |            |
|----------|--|------------|
| 4.18     | CardBus Latency Timer Register                                     | 4-11       |
| 4.19     | CardBus Memory Base Registers 0, 1                                 | 4-11       |
| 4.20     | CardBus Memory Limit Registers 0, 1                                | 4-12       |
| 4.21     | CardBus I/O Base Registers 0, 1                                    | 4-12       |
| 4.22     | CardBus I/O Limit Registers 0, 1                                   | 4-13       |
| 4.23     | Interrupt Line Register  | 4-13       |
| 4.24     | Interrupt Pin Register   | 4-14       |
| 4.25     | Bridge Control Register  | 4-15       |
| 4.26     | Subsystem Vendor ID Register                                       | 4-16       |
| 4.27     | Subsystem ID Register  | 4-16       |
| 4.28     | PC Card 16-Bit I/F Legacy-Mode Base-Address Register               | 4-17       |
| 4.29     | System Control Register  | 4-18       |
| 4.30     | MC_CD Debounce Register  | 4-20       |
| 4.31     | General Control Register   | 4-21       |
| 4.32     | General-Purpose Event Status Register                              | 4-22       |
| 4.33     | General-Purpose Event Enable Register                              | 4-23       |
| 4.34     | General-Purpose Input Register                                     | 4-23       |
| 4.35     | General-Purpose Output Register                                    | 4-24       |
| 4.36     | Multifunction Routing Status Register                              | 4-25       |
| 4.37     | Retry Status Register  | 4-26       |
| 4.38     | Card Control Register  | 4-27       |
| 4.39     | Device Control Register  | 4-28       |
| 4.40     | Diagnostic Register  | 4-29       |
| 4.41     | Capability ID Register   | 4-30       |
| 4.42     | Next Item Pointer Register   | 4-30       |
| 4.43     | Power Management Capabilities Register                             | 4-31       |
| 4.44     | Power Management Control/Status Register                           | 4-32       |
| 4.45     | Power Management Control/Status Bridge Support Extensions Register | 4-33       |
| 4.46     | Power-Management Data Register                                     | 4-33       |
| 4.47     | Serial Bus Data Register   | 4-34       |
| 4.48     | Serial Bus Index Register  | 4-34       |
| 4.49     | Serial Bus Slave Address Register                                  | 4-35       |
| 4.50     | Serial Bus Control/Status Register                                 | 4-36       |
| <b>5</b> | <b>ExCA Compatibility Registers (Functions 0 and 1)</b>            | <b>5-1</b> |
| 5.1      | ExCA Identification and Revision Register                          | 5-5        |
| 5.2      | ExCA Interface Status Register                                     | 5-6        |
| 5.3      | ExCA Power Control Register  | 5-7        |
| 5.4      | ExCA Interrupt and General Control Register                        | 5-8        |
| 5.5      | ExCA Card Status-Change Register                                   | 5-9        |
| 5.6      | ExCA Card Status-Change Interrupt Configuration Register           | 5-10       |
| 5.7      | ExCA Address Window Enable Register                                | 5-11       |
| 5.8      | ExCA I/O Window Control Register                                   | 5-12       |
| 5.9      | ExCA I/O Windows 0 and 1 Start-Address Low-Byte Registers          | 5-13       |

|          |  |            |
|----------|--|------------|
| 5.10     | ExCA I/O Windows 0 and 1 Start-Address High-Byte Registers . . . . | 5–13       |
| 5.11     | ExCA I/O Windows 0 and 1 End-Address Low-Byte Registers . . . . .  | 5–14       |
| 5.12     | ExCA I/O Windows 0 and 1 End-Address High-Byte Registers . . . .   | 5–14       |
| 5.13     | ExCA Memory Windows 0–4 Start-Address Low-Byte Registers . . .     | 5–15       |
| 5.14     | ExCA Memory Windows 0–4 Start-Address High-Byte Registers . . .    | 5–16       |
| 5.15     | ExCA Memory Windows 0–4 End-Address Low-Byte Registers . . . .     | 5–17       |
| 5.16     | ExCA Memory Windows 0–4 End-Address High-Byte Registers . . .      | 5–18       |
| 5.17     | ExCA Memory Windows 0–4 Offset-Address Low-Byte Registers . .      | 5–19       |
| 5.18     | ExCA Memory Windows 0–4 Offset-Address High-Byte Registers .       | 5–20       |
| 5.19     | ExCA Card Detect and General Control Register . . . . .            | 5–21       |
| 5.20     | ExCA Global Control Register . . . . .                             | 5–22       |
| 5.21     | ExCA I/O Windows 0 and 1 Offset-Address Low-Byte Registers . . .   | 5–23       |
| 5.22     | ExCA I/O Windows 0 and 1 Offset-Address High-Byte Registers . . .  | 5–23       |
| 5.23     | ExCA Memory Windows 0–4 Page Registers . . . . .                   | 5–24       |
| <b>6</b> | <b>CardBus Socket Registers (Functions 0 and 1) . . . . .</b>      | <b>6–1</b> |
| 6.1      | Socket Event Register . . . . .                                    | 6–2        |
| 6.2      | Socket Mask Register . . . . .                                     | 6–3        |
| 6.3      | Socket Present State Register . . . . .                            | 6–4        |
| 6.4      | Socket Force Event Register . . . . .                              | 6–5        |
| 6.5      | Socket Control Register . . . . .                                  | 6–7        |
| 6.6      | Socket Power Management Register . . . . .                         | 6–8        |
| <b>7</b> | <b>Flash Media Controller Programming Model . . . . .</b>          | <b>7–1</b> |
| 7.1      | Vendor ID Register . . . . .                                       | 7–2        |
| 7.2      | Device ID Register . . . . .                                       | 7–2        |
| 7.3      | Command Register . . . . .   | 7–3        |
| 7.4      | Status Register . . . . .  | 7–4        |
| 7.5      | Class Code and Revision ID Register . . . . .                      | 7–5        |
| 7.6      | Latency Timer and Class Cache Line Size Register . . . . .         | 7–5        |
| 7.7      | Header Type and BIST Register . . . . .                            | 7–6        |
| 7.8      | Flash Media Base Address Register . . . . .                        | 7–6        |
| 7.9      | Subsystem Vendor Identification Register . . . . .                 | 7–7        |
| 7.10     | Subsystem Identification Register . . . . .                        | 7–7        |
| 7.11     | Capabilities Pointer Register . . . . .                            | 7–7        |
| 7.12     | Interrupt Line Register . . . . .                                  | 7–8        |
| 7.13     | Interrupt Pin Register . . . . .                                   | 7–8        |
| 7.14     | Minimum Grant Register . . . . .                                   | 7–9        |
| 7.15     | Maximum Latency Register . . . . .                                 | 7–9        |
| 7.16     | Capability ID and Next Item Pointer Registers . . . . .            | 7–10       |
| 7.17     | Power Management Capabilities Register . . . . .                   | 7–11       |
| 7.18     | Power Management Control and Status Register . . . . .             | 7–12       |
| 7.19     | Power Management Bridge Support Extension Register . . . . .       | 7–12       |
| 7.20     | Power Management Data Register . . . . .                           | 7–13       |
| 7.21     | General Control Register . . . . .                                 | 7–13       |
| 7.22     | Subsystem Access Register . . . . .                                | 7–14       |

|          |   |            |
|----------|---|------------|
| 7.23     | Diagnostic Register .....   | 7-15       |
| <b>8</b> | <b>Electrical Characteristics .....</b>   | <b>8-1</b> |
| 8.1      | Absolute Maximum Ratings Over Operating Temperature Ranges .  | 8-1        |
| 8.2      | Recommended Operating Conditions .....  | 8-1        |
| 8.3      | Electrical Characteristics Over Recommended Operating<br>Conditions .....   | 8-3        |
| 8.4      | Electrical Characteristics Over Recommended Ranges of<br>Operating Conditions .....                                     | 8-3        |
| 8.4.1    | Device .....  | 8-3        |
| 8.4.2    | Driver .....  | 8-4        |
| 8.4.3    | Receiver .....  | 8-4        |
| 8.5      | PCI Clock/Reset Timing Requirements Over Recommended<br>Ranges of Supply Voltage and Operating Free-Air Temperature ... | 8-4        |
| 8.6      | Switching Characteristics for PHY Port Interface .....  | 8-5        |
| 8.7      | Operating, Timing, and Switching Characteristics of XI .....  | 8-5        |
| 8.8      | PCI Timing Requirements Over Recommended Ranges of<br>Supply Voltage and Operating Free-Air Temperature .....           | 8-5        |
| <b>9</b> | <b>Mechanical Information .....</b>   | <b>9-1</b> |

## List of Illustrations

| <i>Figure</i> | <i>Title</i>   | <i>Page</i> |
|---------------|--|-------------|
| 2-1           | PCI6x20 GHK-Package Terminal Diagram .....                                 | 2-1         |
| 3-1           | PCI6x20 System Block Diagram .....   | 3-1         |
| 3-2           | 3-State Bidirectional Buffer .....   | 3-2         |
| 3-3           | Serial ROM Application .....   | 3-4         |
| 3-4           | SPKROUT Connection to Speaker Driver .....                                 | 3-9         |
| 3-5           | Two Sample LED Circuits .....  | 3-10        |
| 3-6           | Serial-Bus Start/Stop Conditions and Bit Transfers .....                   | 3-12        |
| 3-7           | Serial-Bus Protocol Acknowledge .....                                      | 3-12        |
| 3-8           | Serial-Bus Protocol—Byte Write .....                                       | 3-12        |
| 3-9           | Serial-Bus Protocol—Byte Read .....  | 3-13        |
| 3-10          | EEPROM Interface Doubleword Data Collection .....                          | 3-13        |
| 3-11          | IRQ Implementation .....   | 3-18        |
| 3-12          | System Diagram Implementing CardBus Device Class<br>Power Management ..... | 3-20        |
| 3-13          | Signal Diagram of Suspend Function .....                                   | 3-22        |
| 3-14          | $\overline{RI\_OUT}$ Functional Diagram .....                              | 3-23        |
| 3-15          | Block Diagram of a Status/Enable Cell .....                                | 3-25        |
| 5-1           | ExCA Register Access Through I/O .....                                     | 5-2         |
| 5-2           | ExCA Register Access Through Memory .....                                  | 5-2         |
| 6-1           | Accessing CardBus Socket Registers Through PCI Memory .....                | 6-1         |
| 8-1           | Test Load Diagram .....  | 8-4         |

## List of Tables

| <i>Table</i> | <i>Title</i>   | <i>Page</i> |
|--------------|--|-------------|
| 1–1          | Terms and Definitions .....                                      | 1–4         |
| 2–1          | Signal Names by GHK Terminal Number .....                        | 2–2         |
| 2–2          | CardBus PC Card Signal Names Sorted Alphabetically .....         | 2–6         |
| 2–3          | 16-Bit PC Card Signal Names Sorted Alphabetically .....          | 2–8         |
| 2–4          | Power Supply Terminals .....                                     | 2–10        |
| 2–5          | PC Card Power Switch Terminals .....                             | 2–10        |
| 2–6          | PCI System Terminals .....                                       | 2–11        |
| 2–7          | PCI Address and Data Terminals .....                             | 2–12        |
| 2–8          | PCI Interface Control Terminals .....                            | 2–13        |
| 2–9          | Multifunction and Miscellaneous Terminals .....                  | 2–14        |
| 2–10         | 16-Bit PC Card Address and Data Terminals .....                  | 2–15        |
| 2–11         | 16-Bit PC Card Interface Control Terminals .....                 | 2–16        |
| 2–12         | CardBus PC Card Interface System Terminals .....                 | 2–17        |
| 2–13         | CardBus PC Card Address and Data Terminals .....                 | 2–18        |
| 2–14         | CardBus PC Card Interface Control Terminals .....                | 2–19        |
| 2–15         | MMC/SD Terminals .....   | 2–20        |
| 2–16         | Memory Stick Terminals .....                                     | 2–20        |
| 2–17         | Smart Card Mapping to the PCMCIA 68-Terminal Connector .....     | 2–21        |
| 2–18         | Smart Card Terminals (Sockets A and B) .....                     | 2–22        |
| 3–1          | PC Card—Card Detect and Voltage Sense Connections .....          | 3–7         |
| 3–2          | TPS2228 Control Logic—xVPP/VCORE .....                           | 3–8         |
| 3–3          | TPS2228 Control Logic—xVCC .....                                 | 3–8         |
| 3–4          | TPS2226 Control Logic—xVPP .....                                 | 3–8         |
| 3–5          | TPS2226 Control Logic—xVCC .....                                 | 3–8         |
| 3–6          | CardBus Socket Registers .....                                   | 3–10        |
| 3–7          | PCI6x20 Registers Used to Program Serial-Bus Devices .....       | 3–11        |
| 3–8          | EEPROM Loading Map .....   | 3–14        |
| 3–9          | Interrupt Mask and Flag Registers .....                          | 3–16        |
| 3–10         | PC Card Interrupt Events and Description .....                   | 3–17        |
| 3–11         | Interrupt Pin Register Cross Reference .....                     | 3–19        |
| 3–12         | SMI Control .....  | 3–19        |
| 3–13         | Requirements for Internal/External 1.8-V Core Power Supply ..... | 3–20        |
| 3–14         | Power-Management Registers .....                                 | 3–24        |
| 3–15         | Function 3 Power-Management Registers .....                      | 3–24        |
| 4–1          | Bit Field Access Tag Descriptions .....                          | 4–1         |
| 4–2          | Functions 0 and 1 PCI Configuration Register Map .....           | 4–1         |
| 4–3          | Command Register Description .....                               | 4–4         |

|      |   |      |
|------|---|------|
| 4-4  | Status Register Description .....   | 4-5  |
| 4-5  | Secondary Status Register Description .....   | 4-9  |
| 4-6  | Interrupt Pin Register Cross Reference .....  | 4-14 |
| 4-7  | Bridge Control Register Description .....   | 4-15 |
| 4-8  | System Control Register Description .....   | 4-18 |
| 4-9  | General Control Register Description .....  | 4-21 |
| 4-10 | General-Purpose Event Status Register Description .....                                 | 4-22 |
| 4-11 | General-Purpose Event Enable Register Description .....                                 | 4-23 |
| 4-12 | General-Purpose Input Register Description .....  | 4-23 |
| 4-13 | General-Purpose Output Register Description .....                                       | 4-24 |
| 4-14 | Multifunction Routing Status Register Description .....                                 | 4-25 |
| 4-15 | Retry Status Register Description .....   | 4-26 |
| 4-16 | Card Control Register Description .....   | 4-27 |
| 4-17 | Device Control Register Description .....   | 4-28 |
| 4-18 | Diagnostic Register Description .....   | 4-29 |
| 4-19 | Power Management Capabilities Register Description .....                                | 4-31 |
| 4-20 | Power Management Control/Status Register Description .....                              | 4-32 |
| 4-21 | Power Management Control/Status Bridge Support Extensions<br>Register Description ..... | 4-33 |
| 4-22 | Serial Bus Data Register Description .....  | 4-34 |
| 4-23 | Serial Bus Index Register Description .....   | 4-34 |
| 4-24 | Serial Bus Slave Address Register Description .....                                     | 4-35 |
| 4-25 | Serial Bus Control/Status Register Description .....                                    | 4-36 |
| 5-1  | ExCA Registers and Offsets .....  | 5-3  |
| 5-2  | ExCA Identification and Revision Register Description .....                             | 5-5  |
| 5-3  | ExCA Interface Status Register Description .....  | 5-6  |
| 5-4  | ExCA Power Control Register Description—82365SL Support .....                           | 5-7  |
| 5-5  | ExCA Power Control Register Description—82365SL-DF Support .....                        | 5-7  |
| 5-6  | ExCA Interrupt and General Control Register Description .....                           | 5-8  |
| 5-7  | ExCA Card Status-Change Register Description .....                                      | 5-9  |
| 5-8  | ExCA Card Status-Change Interrupt Configuration Register<br>Description .....           | 5-10 |
| 5-9  | ExCA Address Window Enable Register Description .....                                   | 5-11 |
| 5-10 | ExCA I/O Window Control Register Description .....                                      | 5-12 |
| 5-11 | ExCA Memory Windows 0-4 Start-Address High-Byte<br>Registers Description .....          | 5-16 |
| 5-12 | ExCA Memory Windows 0-4 End-Address High-Byte<br>Registers Description .....            | 5-18 |
| 5-13 | ExCA Memory Windows 0-4 Offset-Address High-Byte<br>Registers Description .....         | 5-20 |
| 5-14 | ExCA Card Detect and General Control Register Description .....                         | 5-21 |
| 5-15 | ExCA Global Control Register Description .....  | 5-22 |
| 6-1  | CardBus Socket Registers .....  | 6-1  |
| 6-2  | Socket Event Register Description .....   | 6-2  |
| 6-3  | Socket Mask Register Description .....  | 6-3  |

|      |  |      |
|------|--|------|
| 6-4  | Socket Present State Register Description .....                    | 6-4  |
| 6-5  | Socket Force Event Register Description .....                      | 6-6  |
| 6-6  | Socket Control Register Description .....                          | 6-7  |
| 6-7  | Socket Power Management Register Description .....                 | 6-8  |
| 7-1  | Function 3 Configuration Register Map .....                        | 7-1  |
| 7-2  | Command Register Description .....                                 | 7-3  |
| 7-3  | Status Register Description .....                                  | 7-4  |
| 7-4  | Class Code and Revision ID Register Description .....              | 7-5  |
| 7-5  | Latency Timer and Class Cache Line Size Register Description ..... | 7-5  |
| 7-6  | Header Type and BIST Register Description .....                    | 7-6  |
| 7-7  | Flash Media Base Address Register Description .....                | 7-6  |
| 7-8  | PCI Interrupt Pin Register .....                                   | 7-8  |
| 7-9  | Minimum Grant Register Description .....                           | 7-9  |
| 7-10 | Maximum Latency Register Description .....                         | 7-9  |
| 7-11 | Capability ID and Next Item Pointer Registers Description .....    | 7-10 |
| 7-12 | Power Management Capabilities Register Description .....           | 7-11 |
| 7-13 | Power Management Control and Status Register Description .....     | 7-12 |
| 7-14 | General Control Register .....                                     | 7-13 |
| 7-15 | Subsystem Access Register Description .....                        | 7-14 |
| 7-16 | Diagnostic Register Description .....                              | 7-15 |



# 1 Introduction

The Texas Instruments PCI6620 device is an integrated dual-socket PC Card controller, Smart Card controller, and Secure Digital (SD)/MultiMediaCard (MMC), and Memory Stick (MS)/MS-Pro controller. This high-performance integrated solution provides the latest in PC Card, Smart Card, SD, MMC, and Memory Stick technology.

The Texas Instruments PCI6420 device is an integrated dual-socket PC Card controller and SD/MMC MS/MS-Pro controller. This high-performance integrated solution provides the latest in PC Card, SD, MMC, and Memory Stick technology.

For the remainder of this document, PCI6x20 refers to both devices: PCI6620 and PCI6420.

## 1.1 Description

The PCI6620 and PCI6420 are three-function PCI devices compliant with *PCI Local Bus Specification*, Revision 2.3.

Functions 0 and 1 provide the independent PC Card socket controllers compliant with the *PC Card Standard* (Release 8.0). The PCI6x20 device provides features that make it the best choice for bridging between the PCI bus, PC Cards, and Smart Cards and supports any combination of 16-bit, CardBus PC Cards, or Smart Card adapter in the socket powered at 5 V or 3.3 V, as required.

There are no PCMCIA card and socket service software changes required to move systems from the existing CardBus socket controller to the PCI6x20 device. The PCI6x20 device is register compatible with the Intel 82365SL-DF ExCA controller and implements the host interface defined in the *PC Card Standard*. The PCI6x20 internal data path logic allows the host to access 8-, 16-, and 32-bit cards using full 32-bit PCI cycles for maximum performance. Independent buffering and the pipeline architecture provide an unsurpassed performance level with sustained bursting. The PCI6x20 device can be programmed to accept posted writes to improve bus utilization. All card signals are internally buffered to allow hot insertion and removal without external buffering.

The PCI configuration header is accessed through configuration cycles specified by PCI, and it provides plug-and-play (PnP) compatibility. Furthermore, the PCI6x20 device is compliant with the *PCI Bus Power Management Interface Specification*. The PCI6x20 device supports the D0, D1, D2, and D3 power states.

The PCI6x20 design provides PCI bus master bursting, and is capable of transferring a cacheline of data at 132M bytes/s after connection to the memory controller. Because PCI latency can be large, deep FIFOs are provided to buffer the data.

The PCI6x20 device provides physical write posting buffers and a highly-tuned physical data path for SBP-2 performance. The PCI6x20 device also provides multiple isochronous contexts, multiple cacheline burst transfers, advanced internal arbitration, and bus-holding buffers.

Function 3 of the PCI6620 and PCI6420 devices is a dedicated socket that supports SD, MMC, Memory Stick, and Memory Stick-Pro cards. The Flash Media dedicated socket provides separate terminals for SD/MMC and Memory Stick signals so that both an SD/MMC card and a Memory Stick/Memory Stick-Pro card can be used concurrently.

Various implementation specific functions and general-purpose inputs and outputs are provided through eight multifunction terminals. These terminals present a system with options in PCI  $\overline{\text{LOCK}}$ , serial and parallel interrupts, PC Card activity indicator LEDs, and other platform specific signals. PCI-compliant general-purpose events may be programmed and controlled through the multifunction terminals, and an ACPI-compliant programming interface is included for the general-purpose inputs and outputs.

The PCI6x20 device is compliant with the latest *PCI Bus Power Management Specification*, and provides several low-power modes, which enable the host power system to further reduce power consumption.

The PCI6x20 device also has a three-pin serial interface compatible with both the Texas Instruments TPS2226 and TPS2228 power switches. The TPS2226 or TPS2228 power switch provides power to the two CardBus sockets on

the PCI6x20 device. The power to each dedicated socket is controlled through separate power control terminals. Each of these power control pins can be connected to an external 3.3-V power switch.

## 1.2 Features

The PCI6x20 device supports the following features:

- *PC Card Standard 8.0* compliant
- *PCI Bus Power Management Interface Specification 1.1* compliant
- *Advanced Configuration and Power Interface (ACPI) Specification 2.0* compliant
- *PCI Local Bus Specification Revision 2.3* compliant
- PC 98/99 and PC2001 compliant
- Compliant with the *PCI Bus Interface Specification for PCI-to-CardBus Bridges*
- 1.8-V core logic and 3.3-V I/O cells with internal voltage regulator to generate 1.8-V core  $V_{CC}$
- Universal PCI interfaces compatible with 3.3-V and 5-V PCI signaling environments
- Supports PC Card or CardBus with hot insertion and removal
- Supports 132-MBps burst transfers to maximize data throughput on both the PCI bus and the CardBus
- Supports serialized IRQ with PCI interrupts
- Programmable multifunction terminals
- Serial ROM interface for loading subsystem ID and subsystem vendor ID
- ExCA-compatible registers are mapped in memory or I/O space
- Intel 82365SL-DF register compatible
- Supports ring indicate,  $\overline{SUSPEND}$ , and PCI  $\overline{CCLKRUN}$  protocol and PCI bus Lock ( $\overline{LOCK}$ )
- Provides VGA/palette memory and I/O, and subtractive decoding options, LED activity terminals
- Power-down features to conserve energy in battery-powered applications include: automatic device power down during suspend, and ultralow-power sleep mode
- Physical write posting of up to three outstanding transactions
- PCI burst transfers and deep FIFOs to tolerate large host latency
- External cycle timer control for customized synchronization
- Extended resume signaling for compatibility with legacy DV components
- PCI power-management D0, D1, D2, and D3 power states
- Advanced submicron, low-power CMOS technology

## 1.3 Related Documents

- *Advanced Configuration and Power Interface (ACPI) Specification (Revision 2.0)*
- *PC Card Standard (Release 8.0)*
- *PCI Bus Power Management Interface Specification (Revision 1.1)*
- *Serial Bus Protocol 2 (SBP-2)*
- *Serialized IRQ Support for PCI Systems*

- *PCI Mobile Design Guide*
- *PCI Bus Power Management Interface Specification for PCI to CardBus Bridges*
- *PCI14xx Implementation Guide for D3 Wake-Up*
- *PCI to PCMCIA CardBus Bridge Register Description*
- Texas Instruments TPS2226 product data sheet, SLVS317
- Texas Instruments TPS2228 product data sheet, SLVS419
- *PCI Local Bus Specification (Revision 2.3)*
- PCMCIA Proposal (262)
- The Multimedia Card System Specification, Version 3.2, January 2002
- *MMC/SD/SDIO Host Controller Functional Specification WMU\_020\_2* Version 1.5
- SD Memory Card Specifications, SD Group, March 2000
- Memory Stick Standard, Format Specification, Version 2.0
- Memory Stick Format Specification, Version 2.0, (MS-Pro)
- Memory Stick I/F Specification
- ISO Standards for Identification Cards ISO/IEC 7816

## **1.4 Trademarks**

Intel is a trademark of Intel Corporation.

TI and MicroStar BGA are trademarks of Texas Instruments.

i.LINK is a trademark of Sony Corporation of America.

Memory Stick is a trademark of Sony Kabushiki Kaisha TA Sony Corporation, Japan.

Other trademarks are the property of their respective owners.

## 1.5 Terms and Definitions

Terms and definitions used in this document are given in Table 1–1.

**Table 1–1. Terms and Definitions**

| TERM                 | DEFINITIONS   |
|----------------------|---|
| AT                   | AT (advanced technology, as in PC AT) attachment interface  |
| ATA driver           | An existing host software component that loads when any flash media adapter and card is inserted into a PC Card socket. This driver is logically attached to a predefined CIS provided by the PCI6x20 device when the adapter and media are both inserted.            |
| CIS                  | Card information structure. Tuple list defined by the PC Card standard to communicate card information to the host computer   |
| CSR                  | Control and status register   |
| Flash Media          | Memory Stick, MMC, or SD/MMC Flash operating in an ATA compatible mode  |
| ISO/IEC 7816         | The Smart Card standard   |
| Memory Stick™        | A small-form-factor flash interface that is defined, promoted, and licensed by Sony   |
| MMC                  | MultiMediaCard. Specified by the MMC Association, and scope is encompassed by the SD Flash specification.   |
| PCMCIA               | Personal Computer Memory Card International Association. Standards body that governs the PC Card standards  |
| RSVD                 | Reserved for future use   |
| SD Flash             | Secure Digital Flash. Standard governed by the SD Association   |
| Smart Card           | The name applied to ID cards containing integrated circuits, as defined by ISO/IEC 7816-1   |
| SPI                  | Serial peripheral interface, a general-purpose synchronous serial interface. For more information, see the <i>Multimedia Card System Specification</i> , version 3.2.   |
| TI Smart Card driver | A qualified software component provided by Texas Instruments that loads when an UltraMedia-based Smart Card adapter is inserted into a PC Card slot. This driver is logically attached to a CIS provided by the PCI6620 when the adapter and media are both inserted. |
| UltraMedia™          | <i>De facto</i> industry standard promoted by Texas Instruments that integrates CardBus, Smart Card, Memory Stick, and MultiMediaCard/Secure Digital functionality into one controller.   |

## 1.6 Ordering Information

| ORDERING NUMBER | NAME   | VOLTAGE                  | PACKAGE                 |
|-----------------|--|--------------------------|-------------------------|
| PCI6620         | Dual Socket CardBus and Smart Card Controller with Dedicated SD/MS-Pro Sockets | 3.3-V, 5-V tolerant I/Os | 288-ball PBGA (GHK/ZHK) |
| PCI6420         | Dual Socket CardBus Controller with Dedicated SD/MS-Pro Sockets                | 3.3-V, 5-V tolerant I/Os | 288-ball PBGA (GHK/ZHK) |

## 2 Terminal Descriptions

The PCI16x20 device is available in two 288-terminal MicroStar BGA™ packages (GHK/ZHK). The GHK and ZHK packages are mechanically and electrically identical, but the ZHK package is a lead-free (Pb, atomic number 82) design. Throughout the remainder of this manual, only the GHK package designator is used for either the GHK or the ZHK package. The terminal layout for the GHK package is shown in Figure 2–1.

|          |                                |                                 |                                     |                     |                    |                      |                      |                     |                     |                     |                     |                     |                     |                    |                    |                    |                                 |                     |                              |                      |                      |                    |                                     |                   |
|----------|--------------------------------|---------------------------------|-------------------------------------|---------------------|--------------------|----------------------|----------------------|---------------------|---------------------|---------------------|---------------------|---------------------|---------------------|--------------------|--------------------|--------------------|---------------------------------|---------------------|------------------------------|----------------------|----------------------|--------------------|-------------------------------------|-------------------|
| <b>W</b> |                                | C/BE3                           | AD23                                | AD19                | FRAME              | STOP                 | AD15                 | VCCP                | AD9                 | AD7                 | AD5                 | AD0                 | RSVD                | RSVD               | RSVD               | RSVD               | AGN4                            | RSVD                |                              |                      |                      |                    |                                     |                   |
| <b>V</b> | VCCP                           | AD25                            | IDSEL                               | AD20                | AD16               | TRDY                 | SERR                 | AD13                | AD10                | AD8                 | AD4                 | RSVD                | RSVD                | RSVD               | RSVD               | RSVD               | AVD4                            | RSVD                | RSVD                         |                      |                      |                    |                                     |                   |
| <b>U</b> | AD29                           | AD28                            | AD24                                | AD22                | AD18               | IRDY                 | PERR                 | AD14                | GND                 | C/BE0               | AD3                 | RSVD                | AGN2                | RSVD               | AVD3               | NC                 | RSVD                            | RSVD                | VDPLL                        |                      |                      |                    |                                     |                   |
| <b>T</b> | REQ                            | AD31                            | AD27                                |                     |                    |                      |                      |                     |                     |                     |                     |                     |                     |                    |                    |                    | VSPLL                           | RSVD                | RSVD                         |                      |                      |                    |                                     |                   |
| <b>R</b> | PCLK                           | GNT                             | RL_OUT<br>//PME                     |                     | AD21               | C/BE2                | DEVSEL               | AD11                | AD6                 | AD1                 | AVD2                | AGN3                | NC                  |                    |                    |                    | PHY_<br>TEST_<br>MA             | RSVD                | TEST0                        |                      |                      |                    |                                     |                   |
| <b>P</b> | MFUNC6                         | SUSPEND                         | PRST                                |                     | AD30               | AD26                 |                      |                     |                     | C/BE1               |                     |                     |                     | RSVD               | NC                 | NC                 |                                 |                     |                              | B_CAD0<br>//B_D3     | B_CAD2<br>//B_D11    | B_CAD1<br>//B_D4   |                                     |                   |
| <b>N</b> | MFUNC2                         | MFUNC3                          | MFUNC4                              |                     | GRST               |                      | AD17                 | VCC                 | PAR                 | AD12                | AD2                 | RSVD                | NC                  |                    |                    | B_CCDT<br>//B_CDT  |                                 |                     |                              | B_CAD6<br>//B_D13    | B_CAD5<br>//B_D6     | B_RSVD<br>//B_D14  |                                     |                   |
| <b>M</b> | DATA                           | LATCH                           | MFUNC0                              |                     | MFUNC5             |                      | VCC                  | GND                 | GND                 | GND                 | VCC                 | NC                  | VCC                 | B_CAD4<br>//B_D12  | B_CAD3<br>//B_D5   |                    |                                 |                     | B_CC/BE0<br>//B_CET          | B_CAD9<br>//B_A10    | B_CAD8<br>//B_D15    |                    |                                     |                   |
| <b>L</b> | VR_EN                          | CLK_48                          | SDA                                 |                     | CLOCK              | MFUNC1               | SPKROUT              | GND                 | GND                 | GND                 | GND                 | GND                 | B_CAD7<br>//B_D7    |                    |                    | B_CAD10<br>//B_CE2 |                                 |                     |                              | B_CAD13<br>//B_TORD  | B_CAD12<br>//B_A11   | B_CAD11<br>//B_OE  |                                     |                   |
| <b>K</b> | RSVD                           | RSVD                            | RSVD                                |                     | VR_PORT            |                      | SCL                  | VCC                 | GND                 | GND                 | GND                 | VCC                 | B_CAD15<br>//B_TOWR | B_CAD14<br>//B_A9  | B_RSVD<br>//B_A18  |                    |                                 |                     | B_CC/BET<br>//B_A8           | B_CAD16<br>//B_A17   | VCCB                 |                    |                                     |                   |
| <b>J</b> | SD_DAT2                        | SD_DAT3                         | SD_WP                               |                     | RSVD               | RSVD                 | SD_DAT1              | VCC                 | GND                 | GND                 | GND                 | GND                 | B_CPERR<br>//B_A14  |                    |                    | B_CSTOP<br>//B_A20 |                                 |                     |                              | B_CBLOCK<br>//B_A19  | B_CPAR<br>//B_A13    | VR_<br>PORT        |                                     |                   |
| <b>H</b> | SD_CLK                         | SD_CMD                          | SD_DAT0                             |                     | RSVD               |                      | MS_DATA3             | GND                 | GND                 | VCC                 | GND                 | VCC                 | B_CTRDY<br>//B_A22  | B_CAD19<br>//B_A25 | B_CAD17<br>//B_A24 |                    |                                 |                     | B_CCLK<br>//B_A16            | B_CDEVSEL<br>//B_A21 | B_CGNT<br>//B_WE     |                    |                                     |                   |
| <b>G</b> | MS_SPIO<br>(DATA0)             | MS_DATA1                        | MS_DATA2                            |                     | MS_CLK             |                      | VCC                  | VCC                 | A_CSTOP<br>//A_A20  | A_CAD15<br>//A_TOWR | VCC                 | VCC                 | VCC                 |                    |                    | B_CAD21<br>//B_A5  |                                 |                     |                              | B_CC/BE2<br>//B_A12  | B_CFRAME<br>//B_A23  | B_CIRDY<br>//B_A15 |                                     |                   |
| <b>F</b> | MC_PWR<br>_CTRL_0              | MS_BS                           | MC_PWR<br>_CTRL_1                   |                     | A_RSVD<br>//A_D2   | A_CREQ<br>//A_INPACK |                      |                     |                     | A_CIRDY<br>//A_A15  | A_CAD14<br>//A_A9   |                     |                     | A_CAD1             |                    |                    | B_CAD26<br>//B_A0               | B_CAD23<br>//B_A3   |                              |                      |                      | B_CAD20<br>//B_A6  | B_CVS2<br>//B_VS2                   | B_CAD18<br>//B_A7 |
| <b>E</b> | MC_CD_1                        | MC_CD_0                         | A_CAD31<br>//A_D10                  |                     | A_CAD27<br>//A_D0  | A_CAD24<br>//A_A2    | A_CVS2<br>//A_VS2    | A_CFRAME<br>//A_A23 | A_CGNT<br>//A_WE    | A_RSVD<br>//A_A18   | A_CAD10<br>//A_CE2  | A_CAD7<br>//A_D7    | B_CAD31<br>//B_D10  | B_CAD29<br>//B_D1  |                    |                    |                                 |                     |                              |                      | B_CREQ<br>//B_INPACK | B_CAD22<br>//B_A4  | B_CRST<br>//B_RESET                 |                   |
| <b>D</b> | A_CAD30<br>//A_D9              | A_CAD29<br>//A_D1               | A_CAD28<br>//A_D8                   |                     |                    |                      |                      |                     |                     |                     |                     |                     |                     |                    |                    |                    |                                 |                     | B_CAD25<br>//B_A1            | B_CC/BE3<br>//B_REG  | VCCB                 |                    |                                     |                   |
| <b>C</b> | A_CCD2<br>//A_CD2              | A_CCLKRUN<br>//A_WP<br>(IO1S16) | A_CSTSCHG<br>//A_BVD1<br>(STSCHG/R) | A_CVS1              | A_CAD23<br>//A_A3  | A_CRST<br>//A_RESET  | A_CAD18<br>//A_A7    | A_CTRDY<br>//A_A22  | A_CPERR<br>//A_A14  | A_CC/BE1<br>//A_A8  | A_CAD13<br>//A_TORD | A_CAD9<br>//A_A10   | A_CAD5<br>//A_D6    | A_CAD2<br>//A_D11  | B_RSVD<br>//B_D2   | B_CCD2<br>//B_CD2  | B_CAUDIO<br>//B_BVD2<br>(SPKR)  | B_CVS1<br>//B_VS1   | B_CAD24<br>//B_A2            |                      |                      |                    |                                     |                   |
| <b>B</b> | A_CAUDIO<br>//A_BVD2<br>(SPKR) | A_CSERR<br>//A_WAIT             | A_CAD26<br>//A_A0                   | A_CC/BE3<br>//A_REG | A_CAD22<br>//A_A4  | A_CAD20<br>//A_A6    | A_CAD17<br>//A_A24   | A_CCLK<br>//A_A16   | A_CBLOCK<br>//A_A19 | A_CAD16<br>//A_A17  | A_CAD12<br>//A_A11  | A_CC/BE0<br>//A_CET | A_CAD6<br>//A_D13   | A_CAD4<br>//A_D12  | A_CCD1<br>//A_CDT  | B_CAD28<br>//B_D8  | A_CCLKRUN<br>//B_WP<br>(IO1S16) | A_CSERR<br>//B_WAIT | A_CINT<br>//B_READY<br>(REQ) |                      |                      |                    |                                     |                   |
| <b>A</b> | A_CINT/<br>A_READY<br>(REQ)    | A_CAD25<br>//A_A1               | VCCA                                | A_CAD21<br>//A_A5   | A_CAD19<br>//A_A25 | A_CC/BE2<br>//A_A12  | A_CDEVSEL<br>//A_A21 | A_CPAR<br>//A_A13   | VCCA                | A_CAD11<br>//A_OE   | A_CAD8<br>//A_D15   | A_RSVD<br>//A_D14   | A_CAD3<br>//A_D5    | A_CAD0<br>//A_D3   | B_CAD30<br>//B_D9  | B_CAD27<br>//B_D0  |                                 |                     |                              |                      |                      |                    | B_CSTSCHG<br>//B_BVD1<br>(STSCHG/R) |                   |
|          | 1                              | 2                               | 3                                   | 4                   | 5                  | 6                    | 7                    | 8                   | 9                   | 10                  | 11                  | 12                  | 13                  | 14                 | 15                 | 16                 | 17                              | 18                  | 19                           |                      |                      |                    |                                     |                   |

Figure 2–1. PCI16x20 GHK-Package Terminal Diagram

Table 2–1 lists the terminal assignments arranged in terminal-number order, with corresponding signal names for both CardBus and 16-bit PC Cards for the PCI6420 and PCI6620 GHK packages. Table 2–2 and Table 2–3 list the terminal assignments arranged in alphanumeric order by signal name, with corresponding terminal numbers for the GHK package; Table 2–2 is for CardBus signal names and Table 2–3 is for 16-bit PC Card signal names.

Terminal E5 on the GHK package is an identification ball used for device orientation.

**Table 2–1. Signal Names by GHK Terminal Number**

| TERMINAL NUMBER | SIGNAL NAME     |   | TERMINAL NUMBER | SIGNAL NAME     |                |
|-----------------|-----------------|---|-----------------|-----------------|----------------|
|                 | CardBus PC Card | 16-Bit PC Card  |                 | CardBus PC Card | 16-Bit PC Card |
| A02             | A_CINT          | A_READY( $\overline{\text{IREQ}}$ )                       | C04             | A_CVS1          | A_VS1          |
| A03             | A_CAD25         | A_A1  | C05             | A_CAD23         | A_A3           |
| A04             | VCCA            | VCCA  | C06             | A_CRST          | A_RESET        |
| A05             | A_CAD21         | A_A5  | C07             | A_CAD18         | A_A7           |
| A06             | A_CAD19         | A_A25   | C08             | A_CTRDY         | A_A22          |
| A07             | A_CC/BE2        | A_A12   | C09             | A_CPERR         | A_A14          |
| A08             | A_CDEVSEL       | A_A21   | C10             | A_CC/BE1        | A_A8           |
| A09             | A_CPAR          | A_A13   | C11             | A_CAD13         | A_IORD         |
| A10             | VCCA            | VCCA  | C12             | A_CAD9          | A_A10          |
| A11             | A_CAD11         | A_OE  | C13             | A_CAD5          | A_D6           |
| A12             | A_CAD8          | A_D15   | C14             | A_CAD2          | A_D11          |
| A13             | A_RSVD          | A_D14   | C15             | B_RSVD          | B_D2           |
| A14             | A_CAD3          | A_D5  | C16             | B_CCD2          | B_CD2          |
| A15             | A_CAD0          | A_D3  | C17             | B_CAUDIO        | B_BVD2(SPKR)   |
| A16             | B_CAD30         | B_D9  | C18             | B_CVS1          | B_VS1          |
| A17             | B_CAD27         | B_D0  | C19             | B_CAD24         | B_A2           |
| A18             | B_CSTSCHG       | B_BVD1( $\overline{\text{STSCHG}}/\overline{\text{R1}}$ ) | D01             | A_CAD30         | A_D9           |
| B01             | A_CAUDIO        | A_BVD2(SPKR)  | D02             | A_CAD29         | A_D1           |
| B02             | A_CSERR         | A_WAIT  | D03             | A_CAD28         | A_D8           |
| B03             | A_CAD26         | A_A0  | D17             | B_CAD25         | B_A1           |
| B04             | A_CC/BE3        | A_REG   | D18             | B_CC/BE3        | B_REG          |
| B05             | A_CAD22         | A_A4  | D19             | VCCB            | VCCB           |
| B06             | A_CAD20         | A_A6  | E01             | MC_CD_1         | MC_CD_1        |
| B07             | A_CAD17         | A_A24   | E02             | MC_CD_0         | MC_CD_0        |
| B08             | A_CCLK          | A_A16   | E03             | A_CAD31         | A_D10          |
| B09             | A_CBLOCK        | A_A19   | E05             | A_CAD27         | A_D0           |
| B10             | A_CAD16         | A_A17   | E06             | A_CAD24         | A_A2           |
| B11             | A_CAD12         | A_A11   | E07             | A_CVS2          | A_VS2          |
| B12             | A_CC/BE0        | A_CE1   | E08             | A_CFRAME        | A_A23          |
| B13             | A_CAD6          | A_D13   | E09             | A_CGNT          | A_WE           |
| B14             | A_CAD4          | A_D12   | E10             | A_RSVD          | A_A18          |
| B15             | A_CCD1          | A_CD1   | E11             | A_CAD10         | A_CE2          |
| B16             | B_CAD28         | B_D8  | E12             | A_CAD7          | A_D7           |
| B17             | B_CCLKRUN       | B_WP( $\overline{\text{IOIS16}}$ )                        | E13             | B_CAD31         | B_D10          |
| B18             | B_CSERR         | B_WAIT  | E14             | B_CAD29         | B_D1           |
| B19             | B_CINT          | B_READY( $\overline{\text{IREQ}}$ )                       | E17             | B_CREQ          | B_INPACK       |
| C01             | A_CCD2          | A_CD2   | E18             | B_CAD22         | B_A4           |
| C02             | A_CCLKRUN       | A_WP( $\overline{\text{IOIS16}}$ )                        | E19             | B_CRST          | B_RESET        |
| C03             | A_CSTSCHG       | A_BVD1( $\overline{\text{STSCHG}}/\overline{\text{R1}}$ ) | F01             | MC_PWR_CTRL_0   | MC_PWR_CTRL_0  |

**Table 2–1. Signal Names by GHK Terminal Number (Continued)**

| TERMINAL NUMBER | SIGNAL NAME     |                | TERMINAL NUMBER | SIGNAL NAME     |                |
|-----------------|-----------------|----------------|-----------------|-----------------|----------------|
|                 | CardBus PC Card | 16-Bit PC Card |                 | CardBus PC Card | 16-Bit PC Card |
| F02             | MS_BS           | MS_BS          | J01             | SD_DAT2         | SD_DAT2        |
| F03             | MC_PWR_CTRL_1   | MC_PWR_CTRL_1  | J02             | SD_DAT3         | SD_DAT3        |
| F05             | A_RSVD          | A_D2           | J03             | SD_WP           | SD_WP          |
| F06             | A_CREQ          | A_INPACK       | J05             | RSVD            | RSVD           |
| F09             | A_CIRDY         | A_A15          | J06             | RSVD            | RSVD           |
| F10             | A_CAD14         | A_A9           | J07             | SD_DAT1         | SD_DAT1        |
| F12             | A_CAD1          | A_D4           | J08             | VCC             | VCC            |
| F14             | B_CAD26         | B_A0           | J09             | GND             | GND            |
| F15             | B_CAD23         | B_A3           | J10             | GND             | GND            |
| F17             | B_CAD20         | B_A6           | J11             | GND             | GND            |
| F18             | B_CVS2          | B_VS2          | J12             | GND             | GND            |
| F19             | B_CAD18         | B_A7           | J13             | B_CPERR         | B_A14          |
| G01             | MS_SDIO(DATA0)  | MS_SDIO(DATA0) | J15             | B_CSTOP         | B_A20          |
| G02             | MS_DATA1        | MS_DATA1       | J17             | B_CBLOCK        | B_A19          |
| G03             | MS_DATA2        | MS_DATA2       | J18             | B_CPAR          | B_A13          |
| G05             | MS_CLK          | MS_CLK         | J19             | VR_PORT         | VR_PORT        |
| G07             | VCC             | VCC            | K01             | RSVD            | RSVD           |
| G08             | VCC             | VCC            | K02             | RSVD            | RSVD           |
| G09             | A_CSTOP         | A_A20          | K03             | RSVD            | RSVD           |
| G10             | A_CAD15         | A_IOWR         | K05             | VR_PORT         | VR_PORT        |
| G11             | VCC             | VCC            | K07             | SCL             | SCL            |
| G12             | VCC             | VCC            | K08             | VCC             | VCC            |
| G13             | VCC             | VCC            | K09             | GND             | GND            |
| G15             | B_CAD21         | B_A5           | K10             | GND             | GND            |
| G17             | B_CC/BE2        | B_A12          | K11             | GND             | GND            |
| G18             | B_CFRAME        | B_A23          | K12             | VCC             | VCC            |
| G19             | B_CIRDY         | B_A15          | K13             | B_CAD15         | B_IOWR         |
| H01             | SD_CLK          | SD_CLK         | K14             | B_CAD14         | B_A9           |
| H02             | SD_CMD          | SD_CMD         | K15             | B_RSVD          | B_A18          |
| H03             | SD_DAT0         | SD_DAT0        | K17             | B_CC/BE1        | B_A8           |
| H05             | RSVD            | RSVD           | K18             | B_CAD16         | B_A17          |
| H07             | MS_DATA3        | MS_DATA3       | K19             | VCCB            | VCCB           |
| H08             | GND             | GND            | L01             | VR_EN           | VR_EN          |
| H09             | GND             | GND            | L02             | CLK_48          | CLK_48         |
| H10             | VCC             | VCC            | L03             | SDA             | SDA            |
| H11             | GND             | GND            | L05             | CLOCK           | CLOCK          |
| H12             | VCC             | VCC            | L06             | MFUNC1          | MFUNC1         |
| H13             | B_CTRDY         | B_A22          | L07             | SPKROUT         | SPKROUT        |
| H14             | B_CAD19         | B_A25          | L08             | GND             | GND            |
| H15             | B_CAD17         | B_A24          | L09             | GND             | GND            |
| H17             | B_CCLK          | B_A16          | L10             | GND             | GND            |
| H18             | B_CDEVSEL       | B_A21          | L11             | GND             | GND            |
| H19             | B_CGNT          | B_WE           | L12             | GND             | GND            |

Table 2–1. Signal Names by GHK Terminal Number (Continued)

| TERMINAL NUMBER | SIGNAL NAME     |                | TERMINAL NUMBER | SIGNAL NAME     |                |
|-----------------|-----------------|----------------|-----------------|-----------------|----------------|
|                 | CardBus PC Card | 16-Bit PC Card |                 | CardBus PC Card | 16-Bit PC Card |
| L13             | B_CAD7          | B_D7           | P14             | NC              | NC             |
| L15             | B_CAD10         | B_CE2          | P15             | NC              | NC             |
| L17             | B_CAD13         | B_IORD         | P17             | B_CAD0          | B_D3           |
| L18             | B_CAD12         | B_A11          | P18             | B_CAD2          | B_D11          |
| L19             | B_CAD11         | B_OE           | P19             | B_CAD1          | B_D4           |
| M01             | DATA            | DATA           | R01             | PCLK            | PCLK           |
| M02             | LATCH           | LATCH          | R02             | GNT             | GNT            |
| M03             | MFUNC0          | MFUNC0         | R03             | RI_OUT/PME      | RI_OUT/PME     |
| M05             | MFUNC5          | MFUNC5         | R06             | AD21            | AD21           |
| M07             | VCC             | VCC            | R07             | C/BE2           | C/BE2          |
| M08             | GND             | GND            | R08             | DEVSEL          | DEVSEL         |
| M09             | GND             | GND            | R09             | AD11            | AD11           |
| M10             | GND             | GND            | R10             | AD6             | AD6            |
| M11             | VCC             | VCC            | R11             | AD1             | AD1            |
| M12             | NC              | NC             | R12             | AVD2            | AVD2           |
| M13             | VCC             | VCC            | R13             | AGN3            | AGN3           |
| M14             | B_CAD4          | B_D12          | R14             | NC              | NC             |
| M15             | B_CAD3          | B_D5           | R17             | PHY_TEST_MA     | PHY_TEST_MA    |
| M17             | B_CC/BE0        | B_CE1          | R18             | RSVD            | RSVD           |
| M18             | B_CAD9          | B_A10          | R19             | TEST0           | TEST0          |
| M19             | B_CAD8          | B_D15          | T01             | REQ             | REQ            |
| N01             | MFUNC2          | MFUNC2         | T02             | AD31            | AD31           |
| N02             | MFUNC3          | MFUNC3         | T03             | AD27            | AD27           |
| N03             | MFUNC4          | MFUNC4         | T17             | VSPLL           | VSPLL          |
| N05             | GRST            | GRST           | T18             | RSVD            | RSVD           |
| N07             | AD17            | AD17           | T19             | RSVD            | RSVD           |
| N08             | VCC             | VCC            | U01             | AD29            | AD29           |
| N09             | PAR             | PAR            | U02             | AD28            | AD28           |
| N10             | AD12            | AD12           | U03             | AD24            | AD24           |
| N11             | AD2             | AD2            | U04             | AD22            | AD22           |
| N12             | RSVD            | RSVD           | U05             | AD18            | AD18           |
| N13             | NC              | NC             | U06             | IRDY            | IRDY           |
| N15             | B_CCD1          | B_CD1          | U07             | PERR            | PERR           |
| N17             | B_CAD6          | B_D13          | U08             | AD14            | AD14           |
| N18             | B_CAD5          | B_D6           | U09             | GND             | GND            |
| N19             | B_RSVD          | B_D14          | U10             | C/BE0           | C/BE0          |
| P01             | MFUNC6          | MFUNC6         | U11             | AD3             | AD3            |
| P02             | SUSPEND         | SUSPEND        | U12             | RSVD            | RSVD           |
| P03             | PRST            | PRST           | U13             | AGN2            | AGN2           |
| P05             | AD30            | AD30           | U14             | RSVD            | RSVD           |
| P06             | AD26            | AD26           | U15             | AVD3            | AVD3           |
| P09             | C/BE1           | C/BE1          | U16             | NC              | NC             |
| P12             | RSVD            | RSVD           | U17             | RSVD            | RSVD           |

Table 2–1. Signal Names by GHK Terminal Number (Continued)

| TERMINAL NUMBER | SIGNAL NAME     |                | TERMINAL NUMBER | SIGNAL NAME     |                |
|-----------------|-----------------|----------------|-----------------|-----------------|----------------|
|                 | CardBus PC Card | 16-Bit PC Card |                 | CardBus PC Card | 16-Bit PC Card |
| U18             | RSVD            | RSVD           | V18             | RSVD            | RSVD           |
| U19             | VDPLL           | VDPLL          | V19             | RSVD            | RSVD           |
| V01             | VCCP            | VCCP           | W02             | C/BE3           | C/BE3          |
| V02             | AD25            | AD25           | W03             | AD23            | AD23           |
| V03             | IDSEL           | IDSEL          | W04             | AD19            | AD19           |
| V04             | AD20            | AD20           | W05             | FRAME           | FRAME          |
| V05             | AD16            | AD16           | W06             | STOP            | STOP           |
| V06             | TRDY            | TRDY           | W07             | AD15            | AD15           |
| V07             | SERR            | SERR           | W08             | VCCP            | VCCP           |
| V08             | AD13            | AD13           | W09             | AD9             | AD9            |
| V09             | AD10            | AD10           | W10             | AD7             | AD7            |
| V10             | AD8             | AD8            | W11             | AD5             | AD5            |
| V11             | AD4             | AD4            | W12             | AD0             | AD0            |
| V12             | RSVD            | RSVD           | W13             | RSVD            | RSVD           |
| V13             | RSVD            | RSVD           | W14             | RSVD            | RSVD           |
| V14             | RSVD            | RSVD           | W15             | RSVD            | RSVD           |
| V15             | RSVD            | RSVD           | W16             | RSVD            | RSVD           |
| V16             | RSVD            | RSVD           | W17             | AGN4            | AGN4           |
| V17             | AVD4            | AVD4           | W18             | RSVD            | RSVD           |

Table 2–2. CardBus PC Card Signal Names Sorted Alphabetically

| SIGNAL NAME | TERMINAL NUMBER | SIGNAL NAME | TERMINAL NUMBER | SIGNAL NAME | TERMINAL NUMBER | SIGNAL NAME | TERMINAL NUMBER |
|-------------|-----------------|-------------|-----------------|-------------|-----------------|-------------|-----------------|
| AD0         | W12             | A_CAD5      | C13             | A_CPERR     | C09             | B_CAD31     | E13             |
| AD1         | R11             | A_CAD6      | B13             | A_CREQ      | F06             | B_CAUDIO    | C17             |
| AD2         | N11             | A_CAD7      | E12             | A_CRST      | C06             | B_CBLOCK    | J17             |
| AD3         | U11             | A_CAD8      | A12             | A_CSERR     | B02             | B_CCD1      | N15             |
| AD4         | V11             | A_CAD9      | C12             | A_CSTOP     | G09             | B_CCD2      | C16             |
| AD5         | W11             | A_CAD10     | E11             | A_CSTSCHG   | C03             | B_CCLK      | H17             |
| AD6         | R10             | A_CAD11     | A11             | A_CTRDY     | C08             | B_CCLKRUN   | B17             |
| AD7         | W10             | A_CAD12     | B11             | A_CVS1      | C04             | B_CC/BE0    | M17             |
| AD8         | V10             | A_CAD13     | C11             | A_CVS2      | E07             | B_CC/BE1    | K17             |
| AD9         | W09             | A_CAD14     | F10             | A_RSVD      | A13             | B_CC/BE2    | G17             |
| AD10        | V09             | A_CAD15     | G10             | A_RSVD      | E10             | B_CC/BE3    | D18             |
| AD11        | R09             | A_CAD16     | B10             | A_RSVD      | F05             | B_CDEVSEL   | H18             |
| AD12        | N10             | A_CAD17     | B07             | B_CAD0      | P17             | B_CFRAME    | G18             |
| AD13        | V08             | A_CAD18     | C07             | B_CAD1      | P19             | B_CGNT      | H19             |
| AD14        | U08             | A_CAD19     | A06             | B_CAD2      | P18             | B_CINT      | B19             |
| AD15        | W07             | A_CAD20     | B06             | B_CAD3      | M15             | B_CIRDY     | G19             |
| AD16        | V05             | A_CAD21     | A05             | B_CAD4      | M14             | B_CPAR      | J18             |
| AD17        | N07             | A_CAD22     | B05             | B_CAD5      | N18             | B_CPERR     | J13             |
| AD18        | U05             | A_CAD23     | C05             | B_CAD6      | N17             | B_CREQ      | E17             |
| AD19        | W04             | A_CAD24     | E06             | B_CAD7      | L13             | B_CRST      | E19             |
| AD20        | V04             | A_CAD25     | A03             | B_CAD8      | M19             | B_CSERR     | B18             |
| AD21        | R06             | A_CAD26     | B03             | B_CAD9      | M18             | B_CSTOP     | J15             |
| AD22        | U04             | A_CAD27     | E05             | B_CAD10     | L15             | B_CSTSCHG   | A18             |
| AD23        | W03             | A_CAD28     | D03             | B_CAD11     | L19             | B_CTRDY     | H13             |
| AD24        | U03             | A_CAD29     | D02             | B_CAD12     | L18             | B_CVS1      | C18             |
| AD25        | V02             | A_CAD30     | D01             | B_CAD13     | L17             | B_CVS2      | F18             |
| AD26        | P06             | A_CAD31     | E03             | B_CAD14     | K14             | B_RSVD      | C15             |
| AD27        | T03             | A_CAUDIO    | B01             | B_CAD15     | K13             | B_RSVD      | K15             |
| AD28        | U02             | A_CBLOCK    | B09             | B_CAD16     | K18             | B_RSVD      | N19             |
| AD29        | U01             | A_CCD1      | B15             | B_CAD17     | H15             | CLK_48      | L02             |
| AD30        | P05             | A_CCD2      | C01             | B_CAD18     | F19             | CLOCK       | L05             |
| AD31        | T02             | A_CCLK      | B08             | B_CAD19     | H14             | C/BE0       | U10             |
| AGN2        | U13             | A_CCLKRUN   | C02             | B_CAD20     | F17             | C/BE1       | P09             |
| AGN3        | R13             | A_CC/BE0    | B12             | B_CAD21     | G15             | C/BE2       | R07             |
| AGN4        | W17             | A_CC/BE1    | C10             | B_CAD22     | E18             | C/BE3       | W02             |
| AVD2        | R12             | A_CC/BE2    | A07             | B_CAD23     | F15             | DATA        | M01             |
| AVD3        | U15             | A_CC/BE3    | B04             | B_CAD24     | C19             | DEVSEL      | R08             |
| AVD4        | V17             | A_CDEVSEL   | A08             | B_CAD25     | D17             | FRAME       | W05             |
| A_CAD0      | A15             | A_CFRAME    | E08             | B_CAD26     | F14             | GND         | H08             |
| A_CAD1      | F12             | A_CGNT      | E09             | B_CAD27     | A17             | GND         | H09             |
| A_CAD2      | C14             | A_CINT      | A02             | B_CAD28     | B16             | GND         | H11             |
| A_CAD3      | A14             | A_CIRDY     | F09             | B_CAD29     | E14             | GND         | J09             |
| A_CAD4      | B14             | A_CPAR      | A09             | B_CAD30     | A16             | GND         | J10             |

**Table 2–2. CardBus PC Card Signal Names Sorted Alphabetically (Continued)**

| SIGNAL NAME                   | TERMINAL NUMBER | SIGNAL NAME                     | TERMINAL NUMBER | SIGNAL NAME                 | TERMINAL NUMBER |
|-------------------------------|-----------------|---------------------------------|-----------------|-----------------------------|-----------------|
| GND                           | J11             | NC                              | P15             | SD_CLK                      | H01             |
| GND                           | J12             | NC                              | R14             | SD_CMD                      | H02             |
| GND                           | K09             | NC                              | U16             | SD_DAT0                     | H03             |
| GND                           | K10             | PAR                             | N09             | SD_DAT1                     | J07             |
| GND                           | K11             | PCLK                            | R01             | SD_DAT2                     | J01             |
| GND                           | L08             | $\overline{\text{PERR}}$        | U07             | SD_DAT3                     | J02             |
| GND                           | L09             | PHY_TEST_MA                     | R17             | SD_WP                       | J03             |
| GND                           | L10             | $\overline{\text{PRST}}$        | P03             | $\overline{\text{SERR}}$    | V07             |
| GND                           | L11             | $\overline{\text{REQ}}$         | T01             | SPKROUT                     | L07             |
| GND                           | L12             | $\overline{\text{RI\_OUT/PME}}$ | R03             | $\overline{\text{STOP}}$    | W06             |
| GND                           | M08             | RSVD                            | H05             | $\overline{\text{SUSPEND}}$ | P02             |
| GND                           | M09             | RSVD                            | J05             | TEST0                       | R19             |
| GND                           | M10             | RSVD                            | J06             | $\overline{\text{TRDY}}$    | V06             |
| GND                           | U09             | RSVD                            | K01             | VCC                         | G07             |
| $\overline{\text{GNT}}$       | R02             | RSVD                            | K02             | VCC                         | G08             |
| $\overline{\text{GRST}}$      | N05             | RSVD                            | K03             | VCC                         | G11             |
| IDSEL                         | V03             | RSVD                            | N12             | VCC                         | G12             |
| $\overline{\text{IRDY}}$      | U06             | RSVD                            | P12             | VCC                         | G13             |
| $\overline{\text{LATCH}}$     | M02             | RSVD                            | R18             | VCC                         | H10             |
| $\overline{\text{MC\_CD\_1}}$ | E01             | RSVD                            | T18             | VCC                         | H12             |
| $\overline{\text{MC\_CD\_0}}$ | E02             | RSVD                            | T19             | VCC                         | J08             |
| MC_PWR_CTRL_0                 | F01             | RSVD                            | U12             | VCC                         | K08             |
| MC_PWR_CTRL_1                 | F03             | RSVD                            | U14             | VCC                         | K12             |
| MFUNC0                        | M03             | RSVD                            | U17             | VCC                         | M07             |
| MFUNC1                        | L06             | RSVD                            | U18             | VCC                         | M11             |
| MFUNC2                        | N01             | RSVD                            | V12             | VCC                         | M13             |
| MFUNC3                        | N02             | RSVD                            | V13             | VCC                         | N08             |
| MFUNC4                        | N03             | RSVD                            | V14             | VCCA                        | A04             |
| MFUNC5                        | M05             | RSVD                            | V15             | VCCA                        | A10             |
| MFUNC6                        | P01             | RSVD                            | V16             | VCCB                        | D19             |
| MS_BS                         | F02             | RSVD                            | V18             | VCCB                        | K19             |
| MS_CLK                        | G05             | RSVD                            | V19             | VCCP                        | V01             |
| MS_DATA1                      | G02             | RSVD                            | W13             | VCCP                        | W08             |
| MS_DATA2                      | G03             | RSVD                            | W14             | VDPLL                       | U19             |
| MS_DATA3                      | H07             | RSVD                            | W15             | $\overline{\text{VR\_EN}}$  | L01             |
| MS_SDIO(DATA0)                | G01             | RSVD                            | W16             | VR_PORT                     | J19             |
| NC                            | N13             | RSVD                            | W18             | VR_PORT                     | K05             |
| NC                            | M12             | SCL                             | K07             | VSPLL                       | T17             |
| NC                            | P14             | SDA                             | L03             |                             |                 |

**Table 2–3. 16-Bit PC Card Signal Names Sorted Alphabetically**

| SIGNAL NAME | TERMINAL NUMBER | SIGNAL NAME         | TERMINAL NUMBER | SIGNAL NAME            | TERMINAL NUMBER |
|-------------|-----------------|---------------------|-----------------|------------------------|-----------------|
| AD0         | W12             | A_A5                | A05             | $\overline{A\_INPACK}$ | F06             |
| AD1         | R11             | A_A6                | B06             | $\overline{A\_IORD}$   | C11             |
| AD2         | N11             | A_A7                | C07             | $\overline{A\_IOWR}$   | G10             |
| AD3         | U11             | A_A8                | C10             | $\overline{A\_OE}$     | A11             |
| AD4         | V11             | A_A9                | F10             | A_READY(IREQ)          | A02             |
| AD5         | W11             | A_A10               | C12             | $\overline{A\_REG}$    | B04             |
| AD6         | R10             | A_A11               | B11             | A_RESET                | C06             |
| AD7         | W10             | A_A12               | A07             | $\overline{A\_WAIT}$   | B02             |
| AD8         | V10             | A_A13               | A09             | $\overline{A\_WE}$     | E09             |
| AD9         | W09             | A_A14               | C09             | A_WP(IOIS16)           | C02             |
| AD10        | V09             | A_A15               | F09             | $\overline{A\_VS1}$    | C04             |
| AD11        | R09             | A_A16               | B08             | $\overline{A\_VS2}$    | E07             |
| AD12        | N10             | A_A17               | B10             | B_A0                   | F14             |
| AD13        | V08             | A_A18               | E10             | B_A1                   | D17             |
| AD14        | U08             | A_A19               | B09             | B_A2                   | C19             |
| AD15        | W07             | A_A20               | G09             | B_A3                   | F15             |
| AD16        | V05             | A_A21               | A08             | B_A4                   | E18             |
| AD17        | N07             | A_A22               | C08             | B_A5                   | G15             |
| AD18        | U05             | A_A23               | E08             | B_A6                   | F17             |
| AD19        | W04             | A_A24               | B07             | B_A7                   | F19             |
| AD20        | V04             | A_A25               | A06             | B_A8                   | K17             |
| AD21        | R06             | A_BVD1(STSCHG/RI)   | C03             | B_A9                   | K14             |
| AD22        | U04             | A_BVD2(SPKR)        | B01             | B_A10                  | M18             |
| AD23        | W03             | $\overline{A\_CD1}$ | B15             | B_A11                  | L18             |
| AD24        | U03             | $\overline{A\_CD2}$ | C01             | B_A12                  | G17             |
| AD25        | V02             | $\overline{A\_CE1}$ | B12             | B_A13                  | J18             |
| AD26        | P06             | $\overline{A\_CE2}$ | E11             | B_A14                  | J13             |
| AD27        | T03             | A_D0                | E05             | B_A15                  | G19             |
| AD28        | U02             | A_D1                | D02             | B_A16                  | H17             |
| AD29        | U01             | A_D2                | F05             | B_A17                  | K18             |
| AD30        | P05             | A_D3                | A15             | B_A18                  | K15             |
| AD31        | T02             | A_D4                | F12             | B_A19                  | J17             |
| AGN2        | U13             | A_D5                | A14             | B_A20                  | J15             |
| AGN3        | R13             | A_D6                | C13             | B_A21                  | H18             |
| AGN4        | W17             | A_D7                | E12             | B_A22                  | H13             |
| AVD2        | R12             | A_D8                | D03             | B_A23                  | G18             |
| AVD3        | U15             | A_D9                | D01             | B_A24                  | H15             |
| AVD4        | V17             | A_D10               | E03             | B_A25                  | H14             |
| A_A0        | B03             | A_D11               | C14             | B_BVD1(STSCHG/RI)      | A18             |
| A_A1        | A03             | A_D12               | B14             | B_BVD2(SPKR)           | C17             |
| A_A2        | E06             | A_D13               | B13             | $\overline{B\_CD1}$    | N15             |
| A_A3        | C05             | A_D14               | A13             | $\overline{B\_CD2}$    | C16             |
| A_A4        | B05             | A_D15               | A12             | $\overline{B\_CE1}$    | M17             |

**Table 2–3. 16-Bit PC Card Signal Names Sorted Alphabetically (Continued)**

| SIGNAL NAME                  | TERMINAL NUMBER | SIGNAL NAME            | TERMINAL NUMBER | SIGNAL NAME              | TERMINAL NUMBER | SIGNAL NAME          | TERMINAL NUMBER |
|------------------------------|-----------------|------------------------|-----------------|--------------------------|-----------------|----------------------|-----------------|
| $\overline{B\_CE2}$          | L15             | GND                    | H11             | NC                       | N13             | SDA                  | L03             |
| B_D0                         | A17             | GND                    | J09             | NC                       | P14             | SD_CLK               | H01             |
| B_D1                         | E14             | GND                    | J10             | NC                       | P15             | SD_CMD               | H02             |
| B_D2                         | C15             | GND                    | J11             | NC                       | R14             | SD_DAT0              | H03             |
| B_D3                         | P17             | GND                    | J12             | NC                       | U16             | SD_DAT1              | J07             |
| B_D4                         | P19             | GND                    | K09             | PAR                      | N09             | SD_DAT2              | J01             |
| B_D5                         | M15             | GND                    | K10             | PCLK                     | R01             | SD_DAT3              | J02             |
| B_D6                         | N18             | GND                    | K11             | $\overline{PERR}$        | U07             | SD_WP                | J03             |
| B_D7                         | L13             | GND                    | L08             | PHY_TEST_MA              | R17             | $\overline{SERR}$    | V07             |
| B_D8                         | B16             | GND                    | L09             | $\overline{PRST}$        | P03             | SPKROUT              | L07             |
| B_D9                         | A16             | GND                    | L10             | $\overline{REQ}$         | T01             | $\overline{STOP}$    | W06             |
| B_D10                        | E13             | GND                    | L11             | $\overline{RI\_OUT/PME}$ | R03             | $\overline{SUSPEND}$ | P02             |
| B_D11                        | P18             | GND                    | L12             | RSVD                     | H05             | TEST0                | R19             |
| B_D12                        | M14             | GND                    | M08             | RSVD                     | J05             | $\overline{TRDY}$    | V06             |
| B_D13                        | N17             | GND                    | M09             | RSVD                     | J06             | VCC                  | G07             |
| B_D14                        | N19             | GND                    | M10             | RSVD                     | K01             | VCC                  | G08             |
| B_D15                        | M19             | GND                    | U09             | RSVD                     | K02             | VCC                  | G11             |
| $\overline{B\_INPACK}$       | E17             | $\overline{GNT}$       | R02             | RSVD                     | K03             | VCC                  | G12             |
| $\overline{B\_IORD}$         | L17             | $\overline{GRST}$      | N05             | RSVD                     | N12             | VCC                  | G13             |
| $\overline{B\_IOWR}$         | K13             | IDSEL                  | V03             | RSVD                     | P12             | VCC                  | H10             |
| $\overline{B\_OE}$           | L19             | $\overline{IRDY}$      | U06             | RSVD                     | R18             | VCC                  | H12             |
| B_READY( $\overline{IREQ}$ ) | B19             | LATCH                  | M02             | RSVD                     | T18             | VCC                  | J08             |
| $\overline{B\_REG}$          | D18             | $\overline{MC\_CD\_0}$ | E02             | RSVD                     | T19             | VCC                  | K08             |
| B_RESET                      | E19             | $\overline{MC\_CD\_1}$ | E01             | RSVD                     | U12             | VCC                  | K12             |
| $\overline{B\_WAIT}$         | B18             | MC_PWR_CTRL_0          | F01             | RSVD                     | U14             | VCC                  | M07             |
| $\overline{B\_WE}$           | H19             | MC_PWR_CTRL_1          | F03             | RSVD                     | U17             | VCC                  | M11             |
| B_WP( $\overline{IOIS16}$ )  | B17             | MFUNC0                 | M03             | RSVD                     | U18             | VCC                  | M13             |
| $\overline{B\_VS1}$          | C18             | MFUNC1                 | L06             | RSVD                     | V12             | VCC                  | N08             |
| $\overline{B\_VS2}$          | F18             | MFUNC2                 | N01             | RSVD                     | V13             | VCCA                 | A04             |
| CLK_48                       | L02             | MFUNC3                 | N02             | RSVD                     | V14             | VCCA                 | A10             |
| CLOCK                        | L05             | MFUNC4                 | N03             | RSVD                     | V15             | VCCB                 | D19             |
| $\overline{C/BE0}$           | U10             | MFUNC5                 | M05             | RSVD                     | V16             | VCCB                 | K19             |
| $\overline{C/BE1}$           | P09             | MFUNC6                 | P01             | RSVD                     | V18             | VCCP                 | V01             |
| $\overline{C/BE2}$           | R07             | MS_BS                  | F02             | RSVD                     | V19             | VCCP                 | W08             |
| $\overline{C/BE3}$           | W02             | MS_CLK                 | G05             | RSVD                     | W13             | VDPLL                | U19             |
| DATA                         | M01             | MS_DATA1               | G02             | RSVD                     | W14             | $\overline{VR\_EN}$  | L01             |
| $\overline{DEVSEL}$          | R08             | MS_DATA2               | G03             | RSVD                     | W15             | VR_PORT              | J19             |
| $\overline{FRAME}$           | W05             | MS_DATA3               | H07             | RSVD                     | W16             | VR_PORT              | K05             |
| GND                          | H08             | MS_SDIO(DATA0)         | G01             | RSVD                     | W18             | VSPLL                | T17             |
| GND                          | H09             | NC                     | M12             | SCL                      | K07             |                      |                 |

The terminals are grouped in tables by functionality, such as PCI system function, power-supply function, etc. The terminal numbers are also listed for convenient reference.

**Table 2–4. Power Supply Terminals**

| TERMINAL             |  | I/O | DESCRIPTION   |
|----------------------|--|-----|---|
| NAME                 | NUMBER   |     |   |
| AGN2<br>AGN3<br>AGN4 | U13<br>R13<br>W17  | –   | Analog circuit ground terminals   |
| AVD2<br>AVD3<br>AVD4 | R12<br>U15<br>V17  | –   | Analog circuit power terminals. A parallel combination of high frequency decoupling capacitors near each terminal is suggested, such as 0.1 $\mu$ F and 0.001 $\mu$ F. Lower frequency 10- $\mu$ F filtering capacitors are also recommended. These supply terminals are separated from VDPLL and VSPLL internal to the device to provide noise isolation. They must be tied to a low-impedance point on the circuit board. |
| GND                  | H08, H09, H11,<br>J09, J10, J11,<br>J12, K9, K10,<br>K11, L08, L09,<br>L10, L11, L12,<br>M08, M09, M10,<br>U09 | –   | Digital ground terminal   |
| VCC                  | G07, G08, G11,<br>G12, G13, H10,<br>H12, J08, K08,<br>K12, M07, M11,<br>M13, N8                                | –   | Power supply terminal for I/O and internal voltage regulator  |
| VCCA                 | A04, A10   | –   | Clamp voltage for PC Card A interface. Matches card A signaling environment, 5 V or 3.3 V   |
| VCCB                 | D19, K19   | –   | Clamp voltage for PC Card B interface. Matches card B signaling environment, 5 V or 3.3 V   |
| VCCP                 | W08, V01   | –   | Clamp voltage for PCI and miscellaneous I/O, 5 V or 3.3 V   |
| VDPLL                | U19  | –   | PLL circuit power terminal. A parallel combination of high frequency decoupling capacitors near the terminal is suggested, such as 0.1 $\mu$ F and 0.001 $\mu$ F. Lower frequency 10- $\mu$ F filtering capacitors are also recommended. This supply terminal is separated from AVDx internal to the device to provide noise isolation. It must be tied to a low-impedance point on the circuit board.                      |
| VR_EN                | L01  | I   | Internal voltage regulator enable. Active low   |
| VR_PORT              | J19, K05   | I/O | 1.8-V output from voltage regulator   |
| VSPLL                | T17  | –   | PLL circuit ground terminal. This terminal must be tied to the low-impedance circuit board ground plane.  |

**Table 2–5. PC Card Power Switch Terminals**

| TERMINAL |        | I/O | DESCRIPTION   |
|----------|--------|-----|---|
| NAME     | NUMBER |     |   |
| CLOCK    | L05    | I/O | Power switch clock. Information on the DATA line is sampled at the rising edge of CLOCK. CLOCK defaults to an input, but can be changed to a PCI6x20 output by using bit 27 (P2CCLK) in the system control register (offset 80h, see Section 4.29). |
| DATA     | M01    | O   | Power switch data. DATA is used to communicate socket power control information serially to the power switch.   |
| LATCH    | M02    | O   | Power switch latch. LATCH is asserted by the PCI6x20 device to indicate to the power switch that the data on the DATA line is valid.  |

**Table 2–6. PCI System Terminals**

| TERMINAL                 |        | I/O | DESCRIPTION   |
|--------------------------|--------|-----|---|
| NAME                     | NUMBER |     |   |
| $\overline{\text{GRST}}$ | N05    | I   | Global reset. When the global reset is asserted, the $\overline{\text{GRST}}$ signal causes the PCI6X20 device to place all output buffers in a high-impedance state and reset all internal registers. When $\overline{\text{GRST}}$ is asserted, the device is completely in its default state. For systems that require wake-up from D3, $\overline{\text{GRST}}$ is normally asserted only during initial boot. $\overline{\text{PRST}}$ must be asserted following initial boot so that PME context is retained when transitioning from D3 to D0. For systems that do not require wake-up from D3, $\overline{\text{GRST}}$ must be tied to $\overline{\text{PRST}}$ . When the $\overline{\text{SUSPEND}}$ mode is enabled, the device is protected from the $\overline{\text{GRST}}$ , and the internal registers are preserved. All outputs are placed in a high-impedance state, but the contents of the registers are preserved. |
| PCLK                     | R01    | I   | PCI bus clock. PCLK provides timing for all transactions on the PCI bus. All PCI signals are sampled at the rising edge of PCLK.  |
| $\overline{\text{PRST}}$ | P03    | I   | PCI bus reset. When the PCI bus reset is asserted, $\overline{\text{PRST}}$ causes the PCI6x20 device to place all output buffers in a high-impedance state and reset some internal registers. When $\overline{\text{PRST}}$ is asserted, the device is completely nonfunctional. When $\overline{\text{SUSPEND}}$ is asserted, the device is protected from $\overline{\text{PRST}}$ clearing the internal registers. All outputs are placed in a high-impedance state, but the contents of the registers are preserved.   |

**Table 2–7. PCI Address and Data Terminals**

| TERMINAL   |                          | I/O | DESCRIPTION   |
|--|--------------------------|-----|---|
| NAME   | NUMBER                   |     |   |
| AD31   | T02                      | I/O | PCI address/data bus. These signals make up the multiplexed PCI address and data bus on the primary interface. During the address phase of a primary-bus PCI cycle, AD31–AD0 contain a 32-bit address or other destination information. During the data phase, AD31–AD0 contain data.   |
| AD30   | P05                      |     |   |
| AD29   | U01                      |     |   |
| AD28   | U02                      |     |   |
| AD27   | T03                      |     |   |
| AD26   | P06                      |     |   |
| AD25   | V02                      |     |   |
| AD24   | U03                      |     |   |
| AD23   | W03                      |     |   |
| AD22   | U04                      |     |   |
| AD21   | R06                      |     |   |
| AD20   | V04                      |     |   |
| AD19   | W04                      |     |   |
| AD18   | U05                      |     |   |
| AD17   | N07                      |     |   |
| AD16   | V05                      |     |   |
| AD15   | W07                      |     |   |
| AD14   | U08                      |     |   |
| AD13   | V08                      |     |   |
| AD12   | N10                      |     |   |
| AD11   | R09                      |     |   |
| AD10   | V09                      |     |   |
| AD9  | W09                      |     |   |
| AD8  | V10                      |     |   |
| AD7  | W10                      |     |   |
| AD6  | R10                      |     |   |
| AD5  | W11                      |     |   |
| AD4  | V11                      |     |   |
| AD3  | U11                      |     |   |
| AD2  | N11                      |     |   |
| AD1  | R11                      |     |   |
| AD0  | W12                      |     |   |
| <u>C/BE3</u><br><u>C/BE2</u><br><u>C/BE1</u><br><u>C/BE0</u> | W02<br>R07<br>P09<br>U10 | I/O | PCI-bus commands and byte enables. These signals are multiplexed on the same PCI terminals. During the address phase of a primary-bus PCI cycle, <u>C/BE3</u> – <u>C/BE0</u> define the bus command. During the data phase, this 4-bit bus is used as byte enables. The byte enables determine which byte paths of the full 32-bit data bus carry meaningful data. <u>C/BE0</u> applies to byte 0 (AD7–AD0), <u>C/BE1</u> applies to byte 1 (AD15–AD8), <u>C/BE2</u> applies to byte 2 (AD23–AD16), and <u>C/BE3</u> applies to byte 3 (AD31–AD24). |
| PAR  | N09                      | I/O | PCI-bus parity. In all PCI-bus read and write cycles, the PCI6x20 device calculates even parity across the AD31–AD0 and <u>C/BE3</u> – <u>C/BE0</u> buses. As an initiator during PCI cycles, the PCI6x20 device outputs this parity indicator with a one-PCLK delay. As a target during PCI cycles, the PCI6x20 device compares its calculated parity to the parity indicator of the initiator. A compare error may result in the assertion of a parity error ( <u>PERR</u> ).   |

**Table 2–8. PCI Interface Control Terminals**

| TERMINAL                   |        | I/O | DESCRIPTION   |
|----------------------------|--------|-----|---|
| NAME                       | NUMBER |     |   |
| $\overline{\text{DEVSEL}}$ | R08    | I/O | PCI device select. The PCI6x20 device asserts $\overline{\text{DEVSEL}}$ to claim a PCI cycle as the target device. As a PCI initiator on the bus, the PCI6x20 device monitors $\overline{\text{DEVSEL}}$ until a target responds. If no target responds before timeout occurs, then the PCI6x20 device terminates the cycle with an initiator abort.   |
| $\overline{\text{FRAME}}$  | W05    | I/O | PCI cycle frame. $\overline{\text{FRAME}}$ is driven by the initiator of a bus cycle. $\overline{\text{FRAME}}$ is asserted to indicate that a bus transaction is beginning, and data transfers continue while this signal is asserted. When $\overline{\text{FRAME}}$ is deasserted, the PCI bus transaction is in the final data phase.   |
| $\overline{\text{GNT}}$    | R02    | I   | PCI bus grant. $\overline{\text{GNT}}$ is driven by the PCI bus arbiter to grant the PCI6x20 device access to the PCI bus after the current data transaction has completed. $\overline{\text{GNT}}$ may or may not follow a PCI bus request, depending on the PCI bus parking algorithm.  |
| IDSEL                      | V03    | I   | Initialization device select. IDSEL selects the PCI6x20 device during configuration space accesses. IDSEL can be connected to one of the upper 24 PCI address lines on the PCI bus.   |
| $\overline{\text{IRDY}}$   | U06    | I/O | PCI initiator ready. $\overline{\text{IRDY}}$ indicates the ability of the PCI bus initiator to complete the current data phase of the transaction. A data phase is completed on a rising edge of PCLK where both $\overline{\text{IRDY}}$ and $\overline{\text{TRDY}}$ are asserted. Until $\overline{\text{IRDY}}$ and $\overline{\text{TRDY}}$ are both sampled asserted, wait states are inserted.  |
| $\overline{\text{PERR}}$   | U07    | I/O | PCI parity error indicator. $\overline{\text{PERR}}$ is driven by a PCI device to indicate that calculated parity does not match PAR when $\overline{\text{PERR}}$ is enabled through bit 6 of the command register (PCI offset 04h, see Section 4.4).  |
| $\overline{\text{REQ}}$    | T01    | O   | PCI bus request. $\overline{\text{REQ}}$ is asserted by the PCI6x20 device to request access to the PCI bus as an initiator.  |
| $\overline{\text{SERR}}$   | V07    | O   | PCI system error. $\overline{\text{SERR}}$ is an output that is pulsed from the PCI6x20 device when enabled through bit 8 of the command register (PCI offset 04h, see Section 4.4) indicating a system error has occurred. The PCI6x20 device need not be the target of the PCI cycle to assert this signal. When $\overline{\text{SERR}}$ is enabled in the command register, this signal also pulses, indicating that an address parity error has occurred on a CardBus interface. |
| $\overline{\text{STOP}}$   | W06    | I/O | PCI cycle stop signal. $\overline{\text{STOP}}$ is driven by a PCI target to request the initiator to stop the current PCI bus transaction. $\overline{\text{STOP}}$ is used for target disconnects and is commonly asserted by target devices that do not support burst data transfers.  |
| $\overline{\text{TRDY}}$   | V06    | I/O | PCI target ready. $\overline{\text{TRDY}}$ indicates the ability of the primary bus target to complete the current data phase of the transaction. A data phase is completed on a rising edge of PCLK when both $\overline{\text{IRDY}}$ and $\overline{\text{TRDY}}$ are asserted. Until both $\overline{\text{IRDY}}$ and $\overline{\text{TRDY}}$ are asserted, wait states are inserted.   |

**Table 2–9. Multifunction and Miscellaneous Terminals**

| TERMINAL                        |                              | I/O | DESCRIPTION   |
|---------------------------------|------------------------------|-----|---|
| NAME                            | NUMBER                       |     |   |
| CLK_48                          | L02                          | I   | Reserved for future 48-MHz clock terminal   |
| MFUNC0                          | M03                          | I/O | Multifunction terminal 0. See Section 4.36, <i>Multifunction Routing Status Register</i> , for configuration details.   |
| MFUNC1                          | L06                          | I/O | Multifunction terminal 1. See Section 4.36, <i>Multifunction Routing Status Register</i> , for configuration details.   |
| MFUNC2                          | N01                          | I/O | Multifunction terminal 2. See Section 4.36, <i>Multifunction Routing Status Register</i> , for configuration details.   |
| MFUNC3                          | N02                          | I/O | Multifunction terminal 3. See Section 4.36, <i>Multifunction Routing Status Register</i> , for configuration details.   |
| MFUNC4                          | N03                          | I/O | Multifunction terminal 4. See Section 4.36, <i>Multifunction Routing Status Register</i> , for configuration details.   |
| MFUNC5                          | M05                          | I/O | Multifunction terminal 5. See Section 4.36, <i>Multifunction Routing Status Register</i> , for configuration details.   |
| MFUNC6                          | P01                          | I/O | Multifunction terminal 6. See Section 4.36, <i>Multifunction Routing Status Register</i> , for configuration details.   |
| PHY_TEST_MA                     | R17                          | I   | PHY test pin. Not for customer use. It must be pulled high with a 4.7-k $\Omega$ resistor.  |
| $\overline{\text{RI\_OUT/PME}}$ | R03                          | O   | Ring indicate out and power management event output. This terminal provides an output for ring-indicate or $\overline{\text{PME}}$ signals.   |
| RSVD                            | H05, J05, J06, K01, K02, K03 |     | Reserved. These terminals have no connection anywhere within the package.   |
| SCL                             | K07                          | I/O | Serial clock. At $\overline{\text{PRST}}$ , the SCL signal is sampled to determine if a two-wire serial ROM is present. If the serial ROM is detected, then this terminal provides the serial clock signaling and is implemented as open-drain. For normal operation (a ROM is implemented in the design), this terminal must be pulled high to the ROM $V_{\text{DD}}$ with a 2.7-k $\Omega$ resistor. Otherwise, it must be pulled low to ground with a 220- $\Omega$ resistor. |
| SDA                             | L03                          | I/O | Serial data. This terminal is implemented as open-drain, and for normal operation (a ROM is implemented in the design), this terminal must be pulled high to the ROM $V_{\text{DD}}$ with a 2.7-k $\Omega$ resistor. Otherwise, it must be pulled low to ground with a 220- $\Omega$ resistor.  |
| SPKROUT                         | L07                          | O   | Speaker output. SPKROUT is the output to the host system that can carry $\overline{\text{SPKR}}$ or CAUDIO through the PCI6x20 device from the PC Card interface. SPKROUT is driven as the exclusive-OR combination of card $\overline{\text{SPKR}}$ //CAUDIO inputs.   |
| $\overline{\text{SUSPEND}}$     | P02                          | I   | Suspend. $\overline{\text{SUSPEND}}$ protects the internal registers from clearing when the $\overline{\text{GRST}}$ or $\overline{\text{PRST}}$ signal is asserted. See Section 3.9.5, <i>Suspend Mode</i> , for details.  |
| TEST0                           | R19                          | I/O | Terminal TEST0 is used for factory test of the device and must be connected to ground for normal operation.   |

**Table 2–10. 16-Bit PC Card Address and Data Terminals**

| SOCKET A TERMINAL |        | SOCKET B TERMINAL |        | I/O | DESCRIPTION   |
|-------------------|--------|-------------------|--------|-----|---|
| NAME              | NUMBER | NAME              | NUMBER |     |   |
| A_A25             | A06    | B_A25             | H14    | O   | PC Card address. 16-bit PC Card address lines. A25 is the most significant bit. |
| A_A24             | B07    | B_A24             | H15    |     |   |
| A_A23             | E08    | B_A23             | G18    |     |   |
| A_A22             | C08    | B_A22             | H13    |     |   |
| A_A21             | A08    | B_A21             | H18    |     |   |
| A_A20             | G09    | B_A20             | J15    |     |   |
| A_A19             | B09    | B_A19             | J17    |     |   |
| A_A18             | E10    | B_A18             | K15    |     |   |
| A_A17             | B10    | B_A17             | K18    |     |   |
| A_A16             | B08    | B_A16             | H17    |     |   |
| A_A15             | F09    | B_A15             | G19    |     |   |
| A_A14             | C09    | B_A14             | J13    |     |   |
| A_A13             | A09    | B_A13             | J18    |     |   |
| A_A12             | A07    | B_A12             | G17    |     |   |
| A_A11             | B11    | B_A11             | L18    |     |   |
| A_A10             | C12    | B_A10             | M18    |     |   |
| A_A9              | F10    | B_A9              | K14    |     |   |
| A_A8              | C10    | B_A8              | K17    |     |   |
| A_A7              | C07    | B_A7              | F19    |     |   |
| A_A6              | B06    | B_A6              | F17    |     |   |
| A_A5              | A05    | B_A5              | G15    |     |   |
| A_A4              | B05    | B_A4              | E18    |     |   |
| A_A3              | C05    | B_A3              | F15    |     |   |
| A_A2              | E06    | B_A2              | C19    |     |   |
| A_A1              | A03    | B_A1              | D17    |     |   |
| A_A0              | B03    | B_A0              | F14    |     |   |
| A_D15             | A12    | B_D15             | M19    | I/O | PC Card data. 16-bit PC Card data lines. D15 is the most significant bit.       |
| A_D14             | A13    | B_D14             | N19    |     |   |
| A_D13             | B13    | B_D13             | N17    |     |   |
| A_D12             | B14    | B_D12             | M14    |     |   |
| A_D11             | C14    | B_D11             | P18    |     |   |
| A_D10             | E03    | B_D10             | E13    |     |   |
| A_D9              | D01    | B_D9              | A16    |     |   |
| A_D8              | D03    | B_D8              | B16    |     |   |
| A_D7              | E12    | B_D7              | L13    |     |   |
| A_D6              | C13    | B_D6              | N18    |     |   |
| A_D5              | A14    | B_D5              | M15    |     |   |
| A_D4              | F12    | B_D4              | P19    |     |   |
| A_D3              | A15    | B_D3              | P17    |     |   |
| A_D2              | F05    | B_D2              | C15    |     |   |
| A_D1              | D02    | B_D1              | E14    |     |   |
| A_D0              | E05    | B_D0              | A17    |     |   |

**Table 2–11. 16-Bit PC Card Interface Control Terminals**

| SOCKET A TERMINAL                                  |            | SOCKET B TERMINAL                                  |            | I/O | DESCRIPTION   |
|--|------------|--|------------|-----|---|
| NAME   | NUMBER     | NAME   | NUMBER     |     |   |
| $\overline{A\_BVD1}$<br>( $\overline{STSCHG/RI}$ ) | C03        | $\overline{B\_BVD1}$<br>( $\overline{STSCHG/RI}$ ) | A18        | I   | Battery voltage detect 1. BVD1 is generated by 16-bit memory PC Cards that include batteries. BVD1 is used with BVD2 as an indication of the condition of the batteries on a memory PC Card. Both BVD1 and BVD2 are high when the battery is good. When BVD2 is low and BVD1 is high, the battery is weak and must be replaced. When BVD1 is low, the battery is no longer serviceable and the data in the memory PC Card is lost. See Section 5.6, <i>ExCA Card Status-Change Interrupt Configuration Register</i> , for enable bits. See Section 5.5, <i>ExCA Card Status-Change Register</i> , and Section 5.2, <i>ExCA Interface Status Register</i> , for the status bits for this signal.<br><br>Status change. $\overline{STSCHG}$ is used to alert the system to a change in the READY, write protect, or battery voltage dead condition of a 16-bit I/O PC Card.<br><br>Ring indicate. $\overline{RI}$ is used by 16-bit modem cards to indicate a ring detection. |
| $\overline{A\_BVD2}$<br>( $\overline{SPKR}$ )      | B01        | $\overline{B\_BVD2}$<br>( $\overline{SPKR}$ )      | C17        | I   | Battery voltage detect 2. BVD2 is generated by 16-bit memory PC Cards that include batteries. BVD2 is used with BVD1 as an indication of the condition of the batteries on a memory PC Card. Both BVD1 and BVD2 are high when the battery is good. When BVD2 is low and BVD1 is high, the battery is weak and must be replaced. When BVD1 is low, the battery is no longer serviceable and the data in the memory PC Card is lost. See Section 5.6, <i>ExCA Card Status-Change Interrupt Configuration Register</i> , for enable bits. See Section 5.5, <i>ExCA Card Status-Change Register</i> , and Section 5.2, <i>ExCA Interface Status Register</i> , for the status bits for this signal.<br><br>Speaker. $\overline{SPKR}$ is an optional binary audio signal available only when the card and socket have been configured for the 16-bit I/O interface. The audio signals from cards A and B are combined by the PCI6x20 device and are output on SPKROUT.          |
| $\overline{A\_CD1}$<br>$\overline{A\_CD2}$         | B15<br>C01 | $\overline{B\_CD1}$<br>$\overline{B\_CD2}$         | N15<br>C16 | I   | Card detect 1 and card detect 2. $\overline{CD1}$ and $\overline{CD2}$ are internally connected to ground on the PC Card. When a PC Card is inserted into a socket, $\overline{CD1}$ and $\overline{CD2}$ are pulled low. For signal status, see Section 5.2, <i>ExCA Interface Status Register</i> .   |
| $\overline{A\_CE1}$<br>$\overline{A\_CE2}$         | B12<br>E11 | $\overline{B\_CE1}$<br>$\overline{B\_CE2}$         | M17<br>L15 | O   | Card enable 1 and card enable 2. $\overline{CE1}$ and $\overline{CE2}$ enable even- and odd-numbered address bytes. $\overline{CE1}$ enables even-numbered address bytes, and $\overline{CE2}$ enables odd-numbered address bytes.  |
| $\overline{A\_INPACK}$                             | F06        | $\overline{B\_INPACK}$                             | E17        | I   | Input acknowledge. $\overline{INPACK}$ is asserted by the PC Card when it can respond to an I/O read cycle at the current address.  |
| $\overline{A\_IORD}$                               | C11        | $\overline{B\_IORD}$                               | L17        | O   | I/O read. $\overline{IORD}$ is asserted by the PCI6x20 device to enable 16-bit I/O PC Card data output during host I/O read cycles.   |
| $\overline{A\_IOWR}$                               | G10        | $\overline{B\_IOWR}$                               | K13        | O   | I/O write. $\overline{IOWR}$ is driven low by the PCI6x20 device to strobe write data into 16-bit I/O PC Cards during host I/O write cycles.  |
| $\overline{A\_OE}$                                 | A11        | $\overline{B\_OE}$                                 | L19        | O   | Output enable. $\overline{OE}$ is driven low by the PCI6x20 device to enable 16-bit memory PC Card data output during host memory read cycles.  |
| $\overline{A\_READY}$<br>( $\overline{IREQ}$ )     | A02        | $\overline{B\_READY}$<br>( $\overline{IREQ}$ )     | B19        | I   | Ready. The ready function is provided when the 16-bit PC Card and the host socket are configured for the memory-only interface. READY is driven low by 16-bit memory PC Cards to indicate that the memory card circuits are busy processing a previous write command. READY is driven high when the 16-bit memory PC Card is ready to accept a new data transfer command.<br><br>Interrupt request. $\overline{IREQ}$ is asserted by a 16-bit I/O PC Card to indicate to the host that a device on the 16-bit I/O PC Card requires service by the host software. IREQ is high (deasserted) when no interrupt is requested.  |

**Table 2–11. 16-Bit PC Card Interface Control Terminals (Continued)**

| SOCKET A TERMINAL                          |            | SOCKET B TERMINAL                          |            | I/O | DESCRIPTION   |
|--|------------|--|------------|-----|---|
| NAME                                       | NUMBER     | NAME                                       | NUMBER     |     |   |
| $\overline{A\_REG}$                        | B04        | $\overline{B\_REG}$                        | D18        | O   | Attribute memory select. $\overline{REG}$ remains high for all common memory accesses. When $\overline{REG}$ is asserted, access is limited to attribute memory ( $\overline{OE}$ or $\overline{WE}$ active) and to the I/O space ( $\overline{IORD}$ or $\overline{IOWR}$ active). Attribute memory is a separately accessed section of card memory and is generally used to record card capacity and other configuration and attribute information.   |
| A_RESET                                    | C06        | B_RESET                                    | E19        | O   | PC Card reset. RESET forces a hard reset to a 16-bit PC Card.   |
| $\overline{A\_VS1}$<br>$\overline{A\_VS2}$ | C04<br>E07 | $\overline{B\_VS1}$<br>$\overline{B\_VS2}$ | C18<br>F18 | I/O | Voltage sense 1 and voltage sense 2. $\overline{VS1}$ and $\overline{VS2}$ , when used in conjunction with each other, determine the operating voltage of the PC Card.  |
| $\overline{A\_WAIT}$                       | B02        | $\overline{B\_WAIT}$                       | B18        | I   | Bus cycle wait. $\overline{WAIT}$ is driven by a 16-bit PC Card to extend the completion of the memory or I/O cycle in progress.  |
| $\overline{A\_WE}$                         | E09        | $\overline{B\_WE}$                         | H19        | O   | Write enable. $\overline{WE}$ is used to strobe memory write data into 16-bit memory PC Cards. $\overline{WE}$ is also used for memory PC Cards that employ programmable memory technologies.   |
| $\overline{A\_WP}$<br>(IOIS16)             | C02        | $\overline{B\_WP}$<br>(IOIS16)             | B17        | I   | Write protect. WP applies to 16-bit memory PC Cards. WP reflects the status of the write-protect switch on 16-bit memory PC Cards. For 16-bit I/O cards, WP is used for the 16-bit port (IOIS16) function.<br>I/O is 16 bits. $\overline{IOIS16}$ applies to 16-bit I/O PC Cards. $\overline{IOIS16}$ is asserted by the 16-bit PC Card when the address on the bus corresponds to an address to which the 16-bit PC Card responds, and the I/O port that is addressed is capable of 16-bit accesses. |

**Table 2–12. CardBus PC Card Interface System Terminals**

| SOCKET A TERMINAL       |        | SOCKET B TERMINAL       |        | I/O | DESCRIPTION   |
|-------------------------|--------|-------------------------|--------|-----|---|
| NAME                    | NUMBER | NAME                    | NUMBER |     |   |
| A_CCLK                  | B08    | B_CCLK                  | H17    | O   | CardBus clock. CCLK provides synchronous timing for all transactions on the CardBus interface. All signals except $\overline{CRST}$ , $\overline{CCLKRUN}$ , $\overline{CINT}$ , $\overline{CSTSCHG}$ , $\overline{CAUDIO}$ , $\overline{CCD2}$ , $\overline{CCD1}$ , $\overline{CVS2}$ , and $\overline{CVS1}$ are sampled on the rising edge of CCLK, and all timing parameters are defined with the rising edge of this signal. CCLK operates at the PCI bus clock frequency, but it can be stopped in the low state or slowed down for power savings. |
| $\overline{A\_CCLKRUN}$ | C02    | $\overline{B\_CCLKRUN}$ | B17    | I/O | CardBus clock run. $\overline{CCLKRUN}$ is used by a CardBus PC Card to request an increase in the CCLK frequency, and by the PCI6x20 device to indicate that the CCLK frequency is going to be decreased.  |
| $\overline{A\_CRST}$    | C06    | $\overline{B\_CRST}$    | E19    | O   | CardBus reset. $\overline{CRST}$ brings CardBus PC Card-specific registers, sequencers, and signals to a known state. When $\overline{CRST}$ is asserted, all CardBus PC Card signals are placed in a high-impedance state, and the PCI6x20 device drives these signals to a valid logic level. Assertion can be asynchronous to CCLK, but deassertion must be synchronous to CCLK.   |

**Table 2–13. CardBus PC Card Address and Data Terminals**

| SOCKET A TERMINAL             |        | SOCKET B TERMINAL             |        | I/O | DESCRIPTION   |
|-------------------------------|--------|-------------------------------|--------|-----|---|
| NAME                          | NUMBER | NAME                          | NUMBER |     |   |
| A_CAD31                       | E03    | B_CAD31                       | E13    | I/O | CardBus address and data. These signals make up the multiplexed CardBus address and data bus on the CardBus interface. During the address phase of a CardBus cycle, CAD31–CAD0 contain a 32-bit address. During the data phase of a CardBus cycle, CAD31–CAD0 contain data. CAD31 is the most significant bit.  |
| A_CAD30                       | D01    | B_CAD30                       | A16    |     |   |
| A_CAD29                       | D02    | B_CAD29                       | E14    |     |   |
| A_CAD28                       | D03    | B_CAD28                       | B16    |     |   |
| A_CAD27                       | E05    | B_CAD27                       | A17    |     |   |
| A_CAD26                       | B03    | B_CAD26                       | F14    |     |   |
| A_CAD25                       | A03    | B_CAD25                       | D17    |     |   |
| A_CAD24                       | E06    | B_CAD24                       | C19    |     |   |
| A_CAD23                       | C05    | B_CAD23                       | F15    |     |   |
| A_CAD22                       | B05    | B_CAD22                       | E18    |     |   |
| A_CAD21                       | A05    | B_CAD21                       | G15    |     |   |
| A_CAD20                       | B06    | B_CAD20                       | F17    |     |   |
| A_CAD19                       | A06    | B_CAD19                       | H14    |     |   |
| A_CAD18                       | C07    | B_CAD18                       | F19    |     |   |
| A_CAD17                       | B07    | B_CAD17                       | H15    |     |   |
| A_CAD16                       | B10    | B_CAD16                       | K18    |     |   |
| A_CAD15                       | G10    | B_CAD15                       | K13    |     |   |
| A_CAD14                       | F10    | B_CAD14                       | K14    |     |   |
| A_CAD13                       | C11    | B_CAD13                       | L17    |     |   |
| A_CAD12                       | B11    | B_CAD12                       | L18    |     |   |
| A_CAD11                       | A11    | B_CAD11                       | L19    |     |   |
| A_CAD10                       | E11    | B_CAD10                       | L15    |     |   |
| A_CAD9                        | C12    | B_CAD9                        | M18    |     |   |
| A_CAD8                        | A12    | B_CAD8                        | M19    |     |   |
| A_CAD7                        | E12    | B_CAD7                        | L13    |     |   |
| A_CAD6                        | B13    | B_CAD6                        | N17    |     |   |
| A_CAD5                        | C13    | B_CAD5                        | N18    |     |   |
| A_CAD4                        | B14    | B_CAD4                        | M14    |     |   |
| A_CAD3                        | A14    | B_CAD3                        | M15    |     |   |
| A_CAD2                        | C14    | B_CAD2                        | P18    |     |   |
| A_CAD1                        | F12    | B_CAD1                        | P19    |     |   |
| A_CAD0                        | A15    | B_CAD0                        | P17    |     |   |
| A_CC/ $\overline{\text{BE}}3$ | B04    | B_CC/ $\overline{\text{BE}}3$ | D18    | I/O | CardBus bus commands and byte enables. $\overline{\text{CC}}/\overline{\text{BE}}3$ – $\overline{\text{CC}}/\overline{\text{BE}}0$ are multiplexed on the same CardBus terminals. During the address phase of a CardBus cycle, $\overline{\text{CC}}/\overline{\text{BE}}3$ – $\overline{\text{CC}}/\overline{\text{BE}}0$ define the bus command. During the data phase, this 4-bit bus is used as byte enables. The byte enables determine which byte paths of the full 32-bit data bus carry meaningful data. $\overline{\text{CC}}/\overline{\text{BE}}0$ applies to byte 0 (CAD7–CAD0), $\overline{\text{CC}}/\overline{\text{BE}}1$ applies to byte 1 (CAD15–CAD8), $\overline{\text{CC}}/\overline{\text{BE}}2$ applies to byte 2 (CAD23–CAD16), and $\overline{\text{CC}}/\overline{\text{BE}}3$ applies to byte 3 (CAD31–CAD24). |
| A_CC/ $\overline{\text{BE}}2$ | A07    | B_CC/ $\overline{\text{BE}}2$ | G17    |     |   |
| A_CC/ $\overline{\text{BE}}1$ | C10    | B_CC/ $\overline{\text{BE}}1$ | K17    |     |   |
| A_CC/ $\overline{\text{BE}}0$ | B12    | B_CC/ $\overline{\text{BE}}0$ | M17    |     |   |
| A_CPAR                        | A09    | B_CPAR                        | J18    | I/O | CardBus parity. In all CardBus read and write cycles, the PCI16x20 device calculates even parity across the CAD and CC/BE buses. As an initiator during CardBus cycles, the PCI16x20 device outputs CPAR with a one-CCLK delay. As a target during CardBus cycles, the PCI16x20 device compares its calculated parity to the parity indicator of the initiator; a compare error results in a parity error assertion.  |

**Table 2–14. CardBus PC Card Interface Control Terminals**

| SOCKET A TERMINAL  |            | SOCKET B TERMINAL  |            | I/O | DESCRIPTION  |
|--|------------|--|------------|-----|--|
| NAME   | NUMBER     | NAME   | NUMBER     |     |  |
| A_AUDIO  | B01        | B_AUDIO  | C17        | I   | CardBus audio. AUDIO is a digital input signal from a PC Card to the system speaker. The PCI6x20 device supports the binary audio mode and outputs a binary signal from the card to SPKROUT.   |
| $\overline{\text{A\_CBLOCK}}$                              | B09        | $\overline{\text{B\_CBLOCK}}$                              | J17        | I/O | CardBus lock. $\overline{\text{CBLOCK}}$ is used to gain exclusive access to a target.   |
| $\overline{\text{A\_CCD1}}$<br>$\overline{\text{A\_CCD2}}$ | B15<br>C01 | $\overline{\text{B\_CCD1}}$<br>$\overline{\text{B\_CCD2}}$ | N15<br>C16 | I   | CardBus detect 1 and CardBus detect 2. $\overline{\text{CCD1}}$ and $\overline{\text{CCD2}}$ are used in conjunction with CVS1 and CVS2 to identify card insertion and interrogate cards to determine the operating voltage and card type.   |
| $\overline{\text{A\_CDEVSEL}}$                             | A08        | $\overline{\text{B\_CDEVSEL}}$                             | H18        | I/O | CardBus device select. The PCI6x20 device asserts $\overline{\text{CDEVSEL}}$ to claim a CardBus cycle as the target device. As a CardBus initiator on the bus, the PCI6x20 device monitors CDEVSEL until a target responds. If no target responds before timeout occurs, then the PCI6x20 device terminates the cycle with an initiator abort.  |
| $\overline{\text{A\_CFRAME}}$                              | E08        | $\overline{\text{B\_CFRAME}}$                              | G18        | I/O | CardBus cycle frame. $\overline{\text{CFRAME}}$ is driven by the initiator of a CardBus bus cycle. $\overline{\text{CFRAME}}$ is asserted to indicate that a bus transaction is beginning, and data transfers continue while this signal is asserted. When $\overline{\text{CFRAME}}$ is deasserted, the CardBus bus transaction is in the final data phase.   |
| $\overline{\text{A\_CGNT}}$                                | E09        | $\overline{\text{B\_CGNT}}$                                | H19        | O   | CardBus bus grant. $\overline{\text{CGNT}}$ is driven by the PCI6x20 device to grant a CardBus PC Card access to the CardBus bus after the current data transaction has been completed.  |
| $\overline{\text{A\_CINT}}$                                | A02        | $\overline{\text{B\_CINT}}$                                | B19        | I   | CardBus interrupt. $\overline{\text{CINT}}$ is asserted low by a CardBus PC Card to request interrupt servicing from the host.   |
| $\overline{\text{A\_CIRDY}}$                               | F09        | $\overline{\text{B\_CIRDY}}$                               | G19        | I/O | CardBus initiator ready. $\overline{\text{CIRDY}}$ indicates the ability of the CardBus initiator to complete the current data phase of the transaction. A data phase is completed on a rising edge of CCLK when both $\overline{\text{CIRDY}}$ and $\overline{\text{CTRDY}}$ are asserted. Until $\overline{\text{CIRDY}}$ and $\overline{\text{CTRDY}}$ are both sampled asserted, wait states are inserted.                       |
| $\overline{\text{A\_CPERR}}$                               | C09        | $\overline{\text{B\_CPERR}}$                               | J13        | I/O | CardBus parity error. $\overline{\text{CPERR}}$ reports parity errors during CardBus transactions, except during special cycles. It is driven low by a target two clocks following the data cycle during which a parity error is detected.   |
| $\overline{\text{A\_CREQ}}$                                | F06        | $\overline{\text{B\_CREQ}}$                                | E17        | I   | CardBus request. $\overline{\text{CREQ}}$ indicates to the arbiter that the CardBus PC Card desires use of the CardBus bus as an initiator.  |
| $\overline{\text{A\_CSERR}}$                               | B02        | $\overline{\text{B\_CSERR}}$                               | B18        | I   | CardBus system error. $\overline{\text{CSERR}}$ reports address parity errors and other system errors that could lead to catastrophic results. $\overline{\text{CSERR}}$ is driven by the card synchronous to CCLK, but deasserted by a weak pullup; deassertion may take several CCLK periods. The PCI6x20 device can report $\overline{\text{CSERR}}$ to the system by assertion of $\overline{\text{SERR}}$ on the PCI interface. |
| $\overline{\text{A\_CSTOP}}$                               | G09        | $\overline{\text{B\_CSTOP}}$                               | J15        | I/O | CardBus stop. $\overline{\text{CSTOP}}$ is driven by a CardBus target to request the initiator to stop the current CardBus transaction. $\overline{\text{CSTOP}}$ is used for target disconnects, and is commonly asserted by target devices that do not support burst data transfers.   |
| A_CSTSCHG  | C03        | B_CSTSCHG  | A18        | I   | CardBus status change. CSTSCHG alerts the system to a change in the card status, and is used as a wake-up mechanism.   |
| $\overline{\text{A\_CTRDY}}$                               | C08        | $\overline{\text{B\_CTRDY}}$                               | H13        | I/O | CardBus target ready. $\overline{\text{CTRDY}}$ indicates the ability of the CardBus target to complete the current data phase of the transaction. A data phase is completed on a rising edge of CCLK, when both $\overline{\text{CIRDY}}$ and $\overline{\text{CTRDY}}$ are asserted; until this time, wait states are inserted.  |
| A_CVS1<br>A_CVS2   | C04<br>E07 | B_CVS1<br>B_CVS2   | C18<br>F18 | I/O | CardBus voltage sense 1 and CardBus voltage sense 2. CVS1 and CVS2 are used in conjunction with $\overline{\text{CCD1}}$ and $\overline{\text{CCD2}}$ to identify card insertion and interrogate cards to determine the operating voltage and card type.   |

**Table 2–15. MMC/SD Terminals**

| TERMINAL                                 |                          | I/O | DESCRIPTION  |
|--|--------------------------|-----|--|
| NAME                                     | NUMBER                   |     |  |
| MC_CD_0                                  | E02                      | I   | Media Card detect. This input is asserted when MMC/SD media are inserted.                                  |
| MC_PWR_CTRL_0                            | F01                      | O   | Media card power control for MMC/SD socket.  |
| SD_DAT3<br>SD_DAT2<br>SD_DAT1<br>SD_DAT0 | J02<br>J01<br>J07<br>H03 | I/O | SD flash data [3:0]. These signals provide the SD data path per the <i>SD Memory Card Specifications</i> . |
| SD_CMD                                   | H02                      | I/O | SD flash command. This signal provides the SD command per the <i>SD Memory Card Specifications</i> .       |
| SD_CLK                                   | H01                      | I/O | SD flash clock. This output provides the MMC/SD clock, which operates at 16 MHz.                           |
| SD_WP                                    | J03                      | I   | SD write protect data. This signal indicates that the media inserted in the socket is write protected.     |

**Table 2–16. Memory Stick Terminals**

| TERMINAL                         |                   | I/O | DESCRIPTION   |
|----------------------------------|-------------------|-----|---|
| NAME                             | NUMBER            |     |   |
| MC_CD_1                          | E01               | I   | Media Card detect. This input is asserted when a Memory Stick or Memory Stick Pro media is inserted.    |
| MC_PWR_CTRL_1                    | F03               | O   | Media card power control for Memory Stick and Memory Stick Pro socket.                                  |
| MS_DATA3<br>MS_DATA2<br>MS_DATA1 | H07<br>G03<br>G02 | I/O | Memory Stick data [3:1]. These signals provide the Memory Stick data path.                              |
| MS_SDIO (DATA0)                  | G01               | I/O | Memory Stick serial data I/O. This signal provides Memory Stick data input/output. Memory Stick data 0. |
| MS_CLK                           | G05               | I/O | Memory Stick clock. This output provides the MS clock, which operates at 16 MHz.                        |
| MS_BS                            | F02               | I/O | Memory Stick bus state. This signal provides Memory Stick bus state information.                        |

Smart Card defines additional functionality for the CardBus/PC Card terminals. Table 2–17 gives the signal names and mapping of this additional functionality to the PCI6x20 CardBus/PC Card terminals, with reference to the 68-pin card socket. Table 2–18 provides the signal descriptions.

**Table 2–17. Smart Card Mapping to the PCMCIA 68-Terminal Connector**

| TERM. | 16-Bit PC Card          | CardBus                     | Smart Card | TERM. | 16-Bit PC Card                      | CardBus                     | Smart Card                |
|-------|-------------------------|-----------------------------|------------|-------|-------------------------------------|-----------------------------|---------------------------|
| 1     | GND                     | GND                         | GND        | 35    | GND                                 | GND                         | GND                       |
| 2     | D3                      | CAD0                        | RSVD       | 36    | $\overline{\text{CD1}}$             | $\overline{\text{CCD1}}$    | $\overline{\text{CCD1}}$  |
| 3     | D4                      | CAD1                        | RSVD       | 37    | D11                                 | CAD2                        | RSVD                      |
| 4     | D5                      | CAD3                        | RSVD       | 38    | D12                                 | CAD4                        | RSVD                      |
| 5     | D6                      | CAD5                        | RSVD       | 39    | D13                                 | CAD6                        | RSVD                      |
| 6     | D7                      | CAD7                        | RSVD       | 40    | D14                                 | RFU                         | RSVD                      |
| 7     | $\overline{\text{CE1}}$ | $\overline{\text{CC/BE0}}$  | RSVD       | 41    | D15                                 | CAD8                        | RSVD                      |
| 8     | A10                     | CAD9                        | RSVD       | 42    | $\overline{\text{CE2}}$             | CAD10                       | RSVD                      |
| 9     | $\overline{\text{OE}}$  | CAD11                       | RSVD       | 43    | $\overline{\text{VS1}}$             | CVS1                        | CVS1                      |
| 10    | A11                     | CAD12                       | RSVD       | 44    | $\overline{\text{IORD/RFU}}$        | CAD13                       | RSVD                      |
| 11    | A9                      | CAD14                       | RSVD       | 45    | $\overline{\text{IOWR/RFU}}$        | CAD15                       | RSVD                      |
| 12    | A8                      | $\overline{\text{CC/BE1}}$  | RSVD       | 46    | A17                                 | CAD16                       | RSVD                      |
| 13    | A13                     | CPAR                        | RSVD       | 47    | A18                                 | RFU                         | SQRY1                     |
| 14    | A14                     | $\overline{\text{CPERR}}$   | RSVD       | 48    | A19                                 | $\overline{\text{CBLOCK}}$  | RSVD                      |
| 15    | $\overline{\text{WE}}$  | $\overline{\text{CGNT}}$    | SC_RFU     | 49    | A20                                 | $\overline{\text{CSTOP}}$   | RSVD                      |
| 16    | READY/IREQ              | $\overline{\text{CINT}}$    | RSVD       | 50    | A21                                 | $\overline{\text{CDEVSEL}}$ | RSVD                      |
| 17    | VCC                     | VCC                         | VCC        | 51    | VCC                                 | VCC                         | VCC                       |
| 18    | Vpp/VCORE               | Vpp/VCORE                   | Vpp/VCORE  | 52    | Vpp/VCORE                           | Vpp/VCORE                   | Vpp/VCORE                 |
| 19    | A16                     | CCLK                        | SC_CLK     | 53    | A22                                 | $\overline{\text{CTRDY}}$   | $\overline{\text{MC_CD}}$ |
| 20    | A15                     | $\overline{\text{CIRDY}}$   | RSVD       | 54    | A23                                 | $\overline{\text{CFRAME}}$  | SC_FCB                    |
| 21    | A12                     | $\overline{\text{CC/BE2}}$  | SC_RST     | 55    | A24                                 | CAD17                       | SC_I/O                    |
| 22    | A7                      | CAD18                       | SC_GPIO0   | 56    | A25                                 | CAD19                       | SQRYDR                    |
| 23    | A6                      | CAD20                       | SC_GPIO1   | 57    | $\overline{\text{VS2}}$             | CVS2                        | CVS2                      |
| 24    | A5                      | CAD21                       | SC_GPIO2   | 58    | RESET                               | $\overline{\text{CRST}}$    | SQRY2                     |
| 25    | A4                      | CAD22                       | SC_GPIO3   | 59    | $\overline{\text{WAIT}}$            | $\overline{\text{CSERR}}$   | SQRY3                     |
| 26    | A3                      | CAD23                       | SC_GPIO4   | 60    | $\overline{\text{INPACK/RFU}}$      | $\overline{\text{CREQ}}$    | SQRY4                     |
| 27    | A2                      | CAD24                       | SC_GPIO5   | 61    | $\overline{\text{REG}}$             | $\overline{\text{CC/BE3}}$  | SQRY5                     |
| 28    | A1                      | CAD25                       | SC_GPIO06  | 62    | $\overline{\text{BVD2(SPKR)}}$      | CAUDIO                      | SQRY6                     |
| 29    | A0                      | CAD26                       | SC_GPIO7   | 63    | $\overline{\text{BVD1(STSCHG/RI)}}$ | CSTSCHG                     | SQRY7                     |
| 30    | D0                      | CAD27                       | RSVD       | 64    | D8                                  | CAD28                       | SQRY8                     |
| 31    | D1                      | CAD29                       | RSVD       | 65    | D9                                  | CAD30                       | SQRY9                     |
| 32    | D2                      | RFU                         | RSVD       | 66    | D10                                 | CAD31                       | SQRY10                    |
| 33    | WP(IOIS16)              | $\overline{\text{CCLKRUN}}$ | RSVD       | 67    | $\overline{\text{CD2}}$             | $\overline{\text{CCD2}}$    | $\overline{\text{CCD2}}$  |
| 34    | GND                     | GND                         | GND        | 68    | GND                                 | GND                         | GND                       |

**Table 2–18. Smart Card Terminals (Sockets A and B)**

| TERMINAL |          |          | I/O | DESCRIPTION  |
|----------|----------|----------|-----|--|
| NAME     | NUMBER   |          |     |  |
|          | SOCKET A | SOCKET B |     |  |
| SC_CLK   | B08      | H17      | O   | Smart Card clock. The PCI6x20 device drives a 3-MHz clock to the Smart Card interface when enabled.  |
| SC_FCB   | E08      | G18      | I   | Smart Card function code. The PCI6x20 device does not support synchronous Smart Cards as specified in ISO/IEC 7816-10, and this terminal is in a high-impedance state when an UltraMedia Smart Card adapter has been inserted. |
| SC_GPIO0 | C07      | F19      | I/O | Smart Card general-purpose I/O terminals. These signals can be controlled by firmware and are used as control signals for an external Smart Card interface chip or level shifter.  |
| SC_GPIO1 | B06      | F17      | I/O |  |
| SC_GPIO2 | A05      | G15      | I/O |  |
| SC_GPIO3 | B05      | E18      | I/O |  |
| SC_GPIO4 | C05      | F15      | I/O |  |
| SC_GPIO5 | E06      | C19      | I/O |  |
| SC_GPIO6 | A03      | D17      | I/O |  |
| SC_GPIO7 | B03      | F14      | I/O |  |
| SC_IO    | B07      | H15      | I/O | Smart Card input/output. This terminal is the input/output terminal for the character exchange between the PCI6x20 device and the Smart Cards.   |
| SC_RFU   | E09      | H19      | I   | Smart Card reserved. This terminal is in a high-impedance state when an UltraMedia Smart Card adapter has been inserted.   |
| SC_RST   | A07      | G17      | O   | Smart Card reset. This signal starts and stops the Smart Card reset sequence. The PCI6x20 device asserts this reset when requested by the host.  |

### 3 Feature/Protocol Descriptions

The following sections give an overview of the PCI6x20 device. Figure 3–1 shows the connections to the PCI6x20 device. The PCI interface includes all address/data and control signals for PCI protocol. The interrupt interface includes terminals for parallel PCI, parallel ISA, and serialized PCI and ISA signaling.

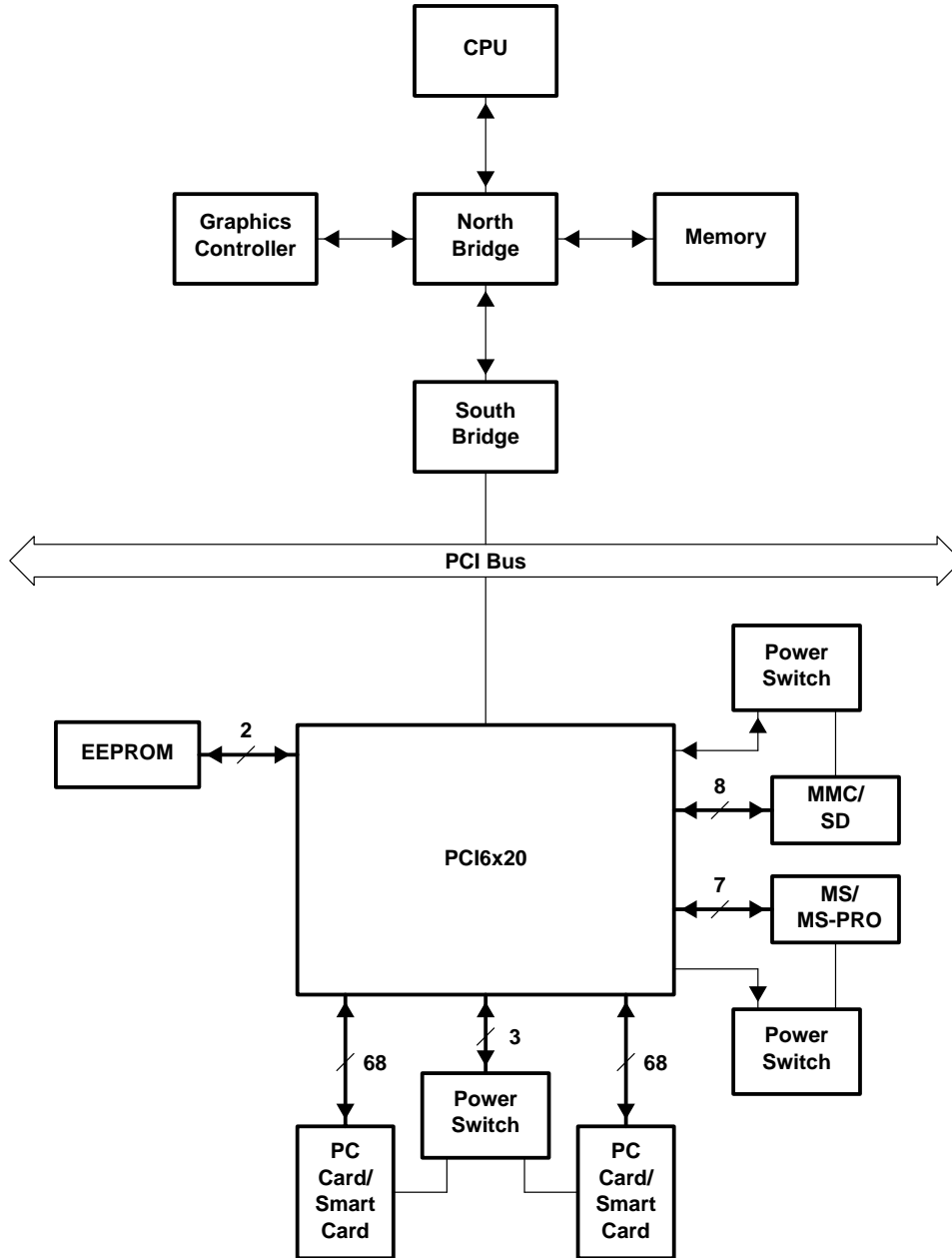

Figure 3–1. PCI6x20 System Block Diagram

### 3.1 Power Supply Sequencing

The PCI6x20 device contains 3.3-V I/O buffers with 5-V tolerance requiring a core power supply and clamp voltages. The core power supply is always 1.8 V. The clamp voltages can be either 3.3 V or 5 V, depending on the interface. The following power-up and power-down sequences are recommended.

The power-up sequence is:

1. Apply the clamp voltage.
2. Apply the I/O voltage.
3. Apply the analog voltage.
4. Power core 1.8 V.

The power-down sequence is:

1. Remove power from the core.
2. Remove the analog voltage.
3. Remove the I/O voltage.
4. Remove the clamp voltage.

**NOTE:** If the voltage regulator is enabled, then steps 2, 3, and 4 of the power-up sequence and steps 1, 2, and 3 of the power-down sequence all occur simultaneously.

### 3.2 I/O Characteristics

The PCI6x20 device meets the ac specifications of the *PC Card Standard* (release 8.0) and *PCI Local Bus Specification*. Figure 3–2 shows a 3-state bidirectional buffer. Section 8.2, *Recommended Operating Conditions*, provides the electrical characteristics of the inputs and outputs.

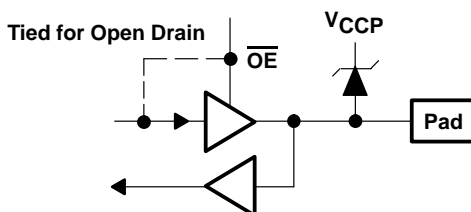

Figure 3–2. 3-State Bidirectional Buffer

### 3.3 Clamping Voltages

The clamping voltages are set to match whatever external environment the PCI6x20 device is interfaced with: 3.3 V or 5 V. The I/O sites can be pulled through a clamping diode to a voltage rail that protects the core from external signals. The core power supply is 1.8 V and is independent of the clamping voltages. For example, PCI signaling can be either 3.3 V or 5 V, and the PCI6x20 device must reliably accommodate both voltage levels. This is accomplished by using a 3.3-V I/O buffer that is 5-V tolerant, with the applicable clamping voltage applied. If a system designer desires a 5-V PCI bus, then  $V_{CCP}$  can be connected to a 5-V power supply.

### 3.4 Peripheral Component Interconnect (PCI) Interface

The PCI6x20 device is fully compliant with the *PCI Local Bus Specification*. The PCI6x20 device provides all required signals for PCI master or slave operation, and may operate in either a 5-V or 3.3-V signaling environment by connecting the  $V_{CCP}$  terminals to the desired voltage level. In addition to the mandatory PCI signals, the PCI6x20 device provides the optional interrupt signals  $\overline{INTA}$ ,  $\overline{INTB}$ ,  $\overline{INTC}$ , and  $\overline{INTD}$ .

### 3.4.1 Device Resets

During the power-up sequence,  $\overline{\text{GRST}}$  and  $\overline{\text{PRST}}$  must be asserted.  $\overline{\text{GRST}}$  can only be deasserted 100  $\mu\text{s}$  after PCLK is stable.  $\overline{\text{PRST}}$  can be deasserted at the same time as  $\overline{\text{GRST}}$  or any time thereafter.

### 3.4.2 PCI Bus Lock ( $\overline{\text{LOCK}}$ )

The bus-locking protocol defined in the *PCI Local Bus Specification* is not highly recommended, but is provided on the PCI6x20 device as an additional compatibility feature. The PCI  $\overline{\text{LOCK}}$  signal can be routed to the MFUNC4 terminal by setting the appropriate values in bits 19–16 of the multifunction routing status register. See Section 4.36, *Multifunction Routing Status Register*, for details. Note that the use of  $\overline{\text{LOCK}}$  is only supported by PCI-to-CardBus bridges in the downstream direction (away from the processor).

PCI  $\overline{\text{LOCK}}$  indicates an atomic operation that may require multiple transactions to complete. When  $\overline{\text{LOCK}}$  is asserted, nonexclusive transactions can proceed to an address that is not currently locked. A grant to start a transaction on the PCI bus does not assure control of  $\overline{\text{LOCK}}$ ; control of  $\overline{\text{LOCK}}$  is obtained under its own protocol. It is possible for different initiators to use the PCI bus while a single master retains ownership of  $\overline{\text{LOCK}}$ . Note that the CardBus signal for this protocol is  $\overline{\text{CBLOCK}}$  to avoid confusion with the bus clock.

An agent may need to do an exclusive operation because a critical access to memory might be broken into several transactions, but the master wants exclusive rights to a region of memory. The granularity of the lock is defined by PCI to be 16 bytes, aligned. The  $\overline{\text{LOCK}}$  protocol defined by the *PCI Local Bus Specification* allows a resource lock without interfering with nonexclusive real-time data transfer, such as video.

The PCI bus arbiter may be designed to support only complete bus locks using the  $\overline{\text{LOCK}}$  protocol. In this scenario, the arbiter does not grant the bus to any other agent (other than the  $\overline{\text{LOCK}}$  master) while  $\overline{\text{LOCK}}$  is asserted. A complete bus lock may have a significant impact on the performance of the video. The arbiter that supports complete bus  $\overline{\text{LOCK}}$  must grant the bus to the cache to perform a writeback due to a snoop to a modified line when a locked operation is in progress.

The PCI6x20 device supports all  $\overline{\text{LOCK}}$  protocols associated with PCI-to-PCI bridges, as also defined for PCI-to-CardBus bridges. This includes disabling write posting while a locked operation is in progress, which can solve a potential deadlock when using devices such as PCI-to-PCI bridges. The potential deadlock can occur if a CardBus target supports delayed transactions and blocks access to the target until it completes a delayed read. This target characteristic is prohibited by the *PCI Local Bus Specification*, and the issue is resolved by the PCI master using  $\overline{\text{LOCK}}$ .

### 3.4.3 Serial EEPROM I<sup>2</sup>C Bus

The PCI6x20 device offers many choices for modes of operation, and these choices are selected by programming several configuration registers. For system board applications, these registers are normally programmed through the BIOS routine. For add-in card and docking-station/port-replicator applications, the PCI6x20 device provides a two-wire inter-integrated circuit (IIC or I<sup>2</sup>C) serial bus for use with an external serial EEPROM.

The PCI6x20 device is always the bus master, and the EEPROM is always the slave. Either device can drive the bus low, but neither device drives the bus high. The high level is achieved through the use of pullup resistors on the SCL and SDA signal lines. The PCI6x20 device is always the source of the clock signal, SCL.

System designers who wish to load register values with a serial EEPROM must use pullup resistors on the SCL and SDA terminals. If the PCI6x20 device detects a logic-high level on the SCL terminal at the end of  $\overline{\text{GRST}}$ , then it initiates incremental reads from the external EEPROM. Any size serial EEPROM up to the I<sup>2</sup>C limit of 16 Kbits can be used, but only the first 67 bytes (from offset 00h to offset 42h) are required to configure the PCI6x20 device. Figure 3–3 shows a serial EEPROM application.

In addition to loading configuration data from an EEPROM, the PCI6x20 I<sup>2</sup>C bus can be used to read and write from other I<sup>2</sup>C serial devices. A system designer can control the I<sup>2</sup>C bus, using the PCI6x20 device as bus master, by reading and writing PCI configuration registers. Setting bit 3 (SBDETECT) in the serial bus control/status register (PCI

offset B3h, see Section 4.50) causes the PCI6x20 device to route the SDA and SCL signals to the SDA and SCL terminals, respectively. The read/write data, slave address, and byte addresses are manipulated by accessing the serial bus data, serial bus index, and serial bus slave address registers (PCI offsets B0h, B1h, and B2h; see Sections 4.47, 4.48, and 4.49, respectively).

EEPROM interface status information is communicated through the serial bus control and status register (PCI offset B3h, see Section 4.50). Bit 3 (SBDETECT) in this register indicates whether or not the PCI6x20 serial ROM circuitry detects the pullup resistor on SCL. Any undefined condition, such as a missing acknowledge, results in bit 0 (ROM\_ERR) being set. Bit 4 (ROMBUSY) is set while the subsystem ID register is loading (serial ROM interface is busy).

The subsystem vendor ID for function 3 is also loaded through EEPROM. The EEPROM load data goes to all three functions from the serial EEPROM loader.

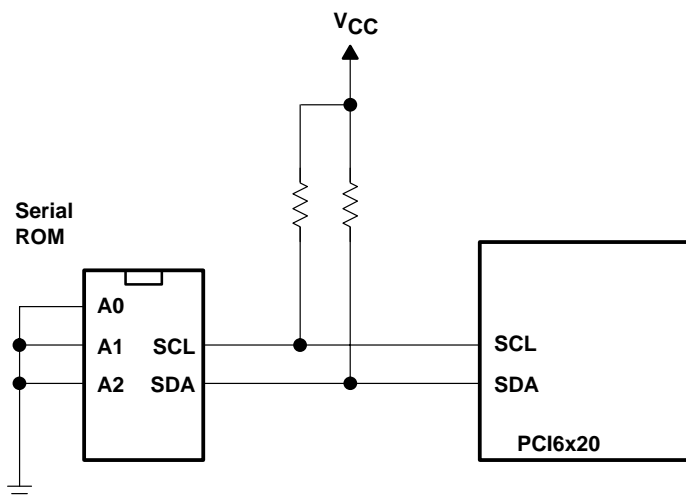

Figure 3-3. Serial ROM Application

### 3.4.4 Functions 0 and 1 (CardBus) Subsystem Identification

The subsystem vendor ID register (PCI offset 40h, see Section 4.26) and subsystem ID register (PCI offset 42h, see Section 4.27) make up a doubleword of PCI configuration space for functions 0 and 1. This doubleword register is used for system and option card (mobile dock) identification purposes and is required by some operating systems. Implementation of this unique identifier register is a *PC 99/PC 2001* requirement.

The PCI6x20 device offers two mechanisms to load a read-only value into the subsystem registers. The first mechanism relies upon the system BIOS providing the subsystem ID value. The default access mode to the subsystem registers is read-only, but can be made read/write by clearing bit 5 (SUBSYSRW) in the system control register (PCI offset 80h, see Section 4.29). Once this bit is cleared, the BIOS can write a subsystem identification value into the registers at PCI offset 40h. The BIOS must set the SUBSYSRW bit such that the subsystem vendor ID register and subsystem ID register is limited to read-only access. This approach saves the added cost of implementing the serial electrically erasable programmable ROM (EEPROM).

In some conditions, such as in a docking environment, the subsystem vendor ID register and subsystem ID register must be loaded with a unique identifier via a serial EEPROM. The PCI6x20 device loads the data from the serial EEPROM after a reset of the primary bus. Note that the  $\overline{\text{SUSPEND}}$  input gates the PCI reset from the entire PCI6x20 core, including the serial-bus state machine (see Section 3.9.5, *Suspend Mode*, for details on using  $\overline{\text{SUSPEND}}$ ).

The PCI6x20 device provides a two-line serial-bus host controller that can interface to a serial EEPROM. See Section 3.7, *Serial EEPROM Interface*, for details on the two-wire serial-bus controller and applications.

### 3.4.5 Function 3 (Flash Media) Subsystem Identification

The subsystem identification register is used for system and option card identification purposes. This register can be initialized from the serial EEPROM or programmed via the subsystem access register at offset F8h in the PCI configuration space (see Section 7.22, *Subsystem Access Register*). See Table 7–15 for a complete description of the register contents.

The contents of the subsystem access register are aliased to the subsystem vendor ID and subsystem ID registers at Function 3 PCI offsets 2Ch and 2Eh, respectively. See Table 7–15 for a complete description of the register contents.

## 3.5 Summary of UltraMedia™ Cards

### 3.5.1 MultiMediaCard (MMC)

The MultiMediaCard is a flash-memory card about the size of a postage stamp and 1,4 mm in thickness. The specification for MMC is governed by the MultiMediaCard Association (MMCA). The interface for MMC cards is based on a 7-terminal serial bus. The MultiMediaCard system specification defines a communication protocol for MMC cards, referred to as MultiMediaCard mode. In addition, all MMC cards work in the alternate SPI mode. The SPI mode allows a microcontroller to interface directly to the MMC card, but at the cost of slower performance.

The voltage range for communication with MMC cards is 2.0 to 3.6 V, and the memory-access voltage range is a card-specific subrange of the communication voltage range. Like SmartMedia cards, MMC cards can be read-only or read/write; however, MMC cards can also have I/O functionality.

MMC cards are designed to be used in either a stand-alone implementation or in a system with other MMC cards. When in the MultiMediaCard mode, the bus protocol can address cards with up to 64K of memory, and up to 30 cards on a single physical bus. However, the maximum data rate is only available with up to 10 MMC cards on the bus. In order to accommodate such a wide variety of system implementations, the MMC clock rate can be varied from 0 to 20 MHz. UltraMedia supports one MMC card per UltraMedia socket.

MMC cards, like SmartMedia cards, are also used in many types of consumer electronic devices. Because of their small size, they are primarily used in portable music players and phones.

### 3.5.2 Secure Digital (SD)

SD cards are the same size as MMC cards, except for the thickness, which at 2,1 mm is slightly thicker than an MMC card. SD cards are based upon MMC cards, with the addition of two terminals. The use of these two terminals and a reserved terminal on MMC cards allows the data bus on SD cards to be up to 4 bits wide instead of the 1-bit width of the MMC data bus. SD cards can communicate in either SD mode or SPI mode.

The voltage range for basic communication with SD cards is 2.0 to 3.6 V, and the voltage range for other commands and memory access is 2.7 to 3.6 V. SD cards can be read-only or read/write.

SD is essentially a superset of MMC, in that MMC cards work in SD systems, but SD cards do not work in current MMC systems. Unlike MMC, each SD card in a system must have a dedicated bus. One of the primary benefits of SD cards is the added security that they provide. SD cards comply with the highest security of SDMI, have built-in write-protect features, and include a mechanical write-protect switch.

SD cards are used in many of the same devices as MMC cards. The additional security features of the SD cards also allow their use in more-secure applications or in devices where content protection is essential.

### 3.5.3 Memory Stick/MS-Pro

Memory Stick cards are about the size of a stick of gum and are 2,8 mm thick. Developed by Sony, Memory Stick cards have a 10-terminal interface of which three terminals are used for serial communication, two terminals apply power, two terminals are ground, one terminal is for insertion detection, and two terminals are reserved for future use. Each card also includes an erasure-prevention switch to protect data stored on the card.

The voltage range for Memory Stick cards is 2.7 to 3.6 V, and the clock speed can be up to 20 MHz. Memory Stick cards use the FAT file system to allow for easy communication with PCs.

There are two types of Memory Stick cards, the standard Memory Stick and the MagicGate Memory Stick. MagicGate technology provides security to Memory Stick cards so that they can be used to store and protect copyrighted data.

Memory Stick cards are primarily used to store still images, moving images, voice and music. As such, they are used in a variety of devices, including portable music players, digital cameras, and digital picture frames.

#### **3.5.4 Smart Card**

Smart Cards, also called integrated circuit cards or ICCs, are the same size as a credit card, and they contain an embedded microprocessor chip. Smart Cards can either have contacts or be contactless. In addition, there are both asynchronous and synchronous versions of Smart Cards with contacts. Within this data manual, all uses of the term Smart Card refers only to asynchronous Smart Cards with contacts.

Smart Cards contain eight contacts; however, two of the contacts are reserved for future use and are not included in the UltraMedia interface. Smart Cards can be either 5-V or 3-V cards; however, all 3-V cards are designed to work also at 5 V.

The primary use of Smart Cards is in security-related applications. They are also used in credit cards, debit systems, and identification systems.

### **3.6 PC Card Applications**

The PCI6x20 device supports all the PC Card features and applications as described below.

- Card insertion/removal and recognition per the *PC Card Standard* (release 8.0)
- Speaker and audio applications
- LED socket activity indicators
- PC Card controller programming model
- CardBus socket registers

#### **3.6.1 PC Card Insertion/Removal and Recognition**

The *PC Card Standard* (release 8.0) addresses the card-detection and recognition process through an interrogation procedure that the socket must initiate on card insertion into a cold, nonpowered socket. Through this interrogation, card voltage requirements and interface (16-bit versus CardBus) are determined.

The scheme uses the card-detect and voltage-sense signals. The configuration of these four terminals identifies the card type and voltage requirements of the PC Card interface.

#### **3.6.2 Low Voltage CardBus Card Detection**

The card detection logic of the PCI6x20 device includes the detection of Cardbus cards with  $V_{CC} = 3.3$  V and  $V_{PP} = 1.8$  V. The reporting of the 1.8-V CardBus card ( $V_{CC} = 3.3$  V,  $V_{PP} = 1.8$  V) is reported through the socket present state register as follows based on bit 10 (12V\_SW\_SEL) in the general control register (PCI offset 86h, see Section 4.31):

- If the 12V\_SW\_SEL bit is 0 (TPS2228 is used), then the 1.8-V CardBus card causes the 3VCARD bit in the socket present state register to be set.
- If the 12V\_SW\_SEL bit is 1 (TPS2226 is used), then the 1.8-V CardBus card causes the XVCARD bit in the socket present state register to be set.

#### **3.6.3 UltraMedia Card Detection**

The PCI6x20 device is capable of detecting all the UltraMedia devices defined by the PCMCIA *Proposal 0262* – MultiMedia Cards, Secure Digital, Memory Stick devices, and Smart Card devices. The detection of these devices

is made possible through circuitry included in the PCI6x20 device and the adapters used to interface these devices with the PC Card/CardBus sockets. No additional hardware requirements are placed on the system designer in order to support these devices.

The *PC Card Standard* addresses the card detection and recognition process through an interrogation procedure that the socket must initiate upon card insertion into a cold, unpowered socket. Through this interrogation, card voltage requirements and interface type (16-bit vs. CardBus) are determined. The scheme uses the CD1, CD2, VS1, and VS2 signals (CCD1, CCD2, CVS1, CVS2 for CardBus). A PC Card designer connects these four terminals in a certain configuration to indicate the type of card and its supply voltage requirements. The encoding scheme for this, defined in the *PC Card Standard*, is shown in Table 3–1.

**Table 3–1. PC Card—Card Detect and Voltage Sense Connections**

| $\overline{\text{CD2}}//\overline{\text{CCD2}}$ | $\overline{\text{CD1}}//\overline{\text{CCD1}}$ | $\overline{\text{VS2}}//\overline{\text{CVS2}}$ | $\overline{\text{VS1}}//\overline{\text{CVS1}}$ | Key      | Interface       | VCC                     | Vpp/VCORE     |
|---|---|---|---|----------|-----------------|-------------------------|---------------|
| Ground  | Ground  | Open  | Open  | 5 V      | 16-bit PC Card  | 5 V                     | Per CIS (Vpp) |
| Ground  | Ground  | Open  | Ground  | 5 V      | 16-bit PC Card  | 5 V and 3.3 V           | Per CIS (Vpp) |
| Ground  | Ground  | Ground  | Ground  | 5 V      | 16-bit PC Card  | 5 V, 3.3 V, and X.X V   | Per CIS (Vpp) |
| Ground  | Ground  | Open  | Ground  | LV       | 16-bit PC Card  | 3.3 V                   | Per CIS (Vpp) |
| Ground  | Connect to CVS1                                 | Open  | Connect to CCD1                                 | LV       | CardBus PC Card | 3.3 V                   | Per CIS (Vpp) |
| Ground  | Ground  | Ground  | Ground  | LV       | 16-bit PC Card  | 3.3 V and X.X V         | Per CIS (Vpp) |
| Connect to CVS2                                 | Ground  | Connect to CCD2                                 | Ground  | LV       | CardBus PC Card | 3.3 V and X.X V         | Per CIS (Vpp) |
| Connect to CVS1                                 | Ground  | Ground  | Connect to CCD2                                 | LV       | CardBus PC Card | 3.3 V, X.X V, and Y.Y V | Per CIS (Vpp) |
| Ground  | Ground  | Ground  | Open  | LV       | 16-bit PC Card  | X.X V                   | Per CIS (Vpp) |
| Connect to CVS2                                 | Ground  | Connect to CCD2                                 | Open  | LV       | CardBus PC Card | 3.3 V                   | 1.8 V (VCORE) |
| Ground  | Connect to CVS2                                 | Connect to CCD1                                 | Open  | LV       | CardBus PC Card | X.X V and Y.Y V         | Per CIS (Vpp) |
| Connect to CVS1                                 | Ground  | Open  | Connect to CCD2                                 | LV       | CardBus PC Card | Y.Y V                   | Per CIS (Vpp) |
| Ground  | Connect to CVS1                                 | Ground  | Connect to CCD1                                 | LV       | UltraMedia      | Per query terminals     |               |
| Ground  | Connect to CVS2                                 | Connect to CCD1                                 | Ground  | Reserved |                 | Reserved                |               |

### 3.6.4 Flash Media Card Detection

The PCI7x20 device detects an MMC/SD card insertion through the  $\overline{\text{MC\_CD\_0}}$  terminal. When this terminal is 0, an MMC/SD card is inserted in the socket. The PCI7x20 device debounces the  $\overline{\text{MC\_CD\_0}}$  signal such that instability of the signal does not cause false card insertions. The debounce time is approximately 50 ms. The  $\overline{\text{MC\_CD\_0}}$  signal is not debounced on card removals. The filtered  $\overline{\text{MC\_CD\_0}}$  signal is used in the MMC/SD card detection and power control logic.

The MMC/SD card detection and power control logic contains three main states:

- Socket empty, power off
- Card inserted, power off
- Card inserted, power on

The PCI7x20 device detects a Memory Stick card insertion through the  $\overline{\text{MC\_CD\_1}}$  terminal. When this terminal is 0, a Memory Stick card is inserted in the socket. The PCI7x20 device debounces the  $\overline{\text{MC\_CD\_1}}$  signal such that instability of the signal does not cause false card insertions. The debounce time is approximately 50 ms. The  $\overline{\text{MC\_CD\_1}}$  signal is not debounced on card removals. The filtered  $\overline{\text{MC\_CD\_1}}$  signal is used in the Memory Stick card detection and power control logic.

The Memory Stick card detection and power control logic contains three main states:

- Socket empty, power off
- Card inserted, power off
- Card inserted, power on

### 3.6.5 Power Switch Interface

The power switch interface of the PCI6x20 device is a 3-pin serial interface. This 3-pin interface is implemented such that the PCI6x20 device can connect to both the TPS2226 and TPS2228 power switches. Bit 10 (12V\_SW\_SEL) in the general control register (PCI offset 86h, see Section 4.31) selects the power switch that is implemented. The PCI6x20 device defaults to use the control logic for the TPS2228 power switch. See Table 3–2 through Table 3–5 for the power switch control logic.

**Table 3–2. TPS2228 Control Logic—xVPP/VCORE**

| AVPP/VCORE CONTROL SIGNALS |    |    |    | OUTPUT<br>V_AVPP/VCORE | BVPP/VCORE CONTROL SIGNALS |    |    |     | OUTPUT<br>V_BVPP/VCORE |
|----------------------------|----|----|----|------------------------|----------------------------|----|----|-----|------------------------|
| D8(SHDN)                   | D0 | D1 | D9 |                        | D8(SHDN)                   | D4 | D5 | D10 |                        |
| 1                          | 0  | 0  | X  | 0 V                    | 1                          | 0  | 0  | X   | 0 V                    |
| 1                          | 0  | 1  | 0  | 3.3 V                  | 1                          | 0  | 1  | 0   | 3.3 V                  |
| 1                          | 0  | 1  | 1  | 5 V                    | 1                          | 0  | 1  | 1   | 5 V                    |
| 1                          | 1  | 0  | X  | Hi-Z                   | 1                          | 1  | 0  | X   | Hi-Z                   |
| 1                          | 1  | 1  | 0  | Hi-Z                   | 1                          | 1  | 1  | 0   | Hi-Z                   |
| 1                          | 1  | 1  | 1  | 1.8 V                  | 1                          | 1  | 1  | 1   | 1.8 V                  |
| 0                          | X  | X  | X  | Hi-Z                   | 0                          | X  | X  | X   | Hi-Z                   |

**Table 3–3. TPS2228 Control Logic—xVCC**

| AVCC CONTROL SIGNALS |    |    | OUTPUT<br>V_AVCC | BVCC CONTROL SIGNALS |    |    | OUTPUT<br>V_BVCC |
|----------------------|----|----|------------------|----------------------|----|----|------------------|
| D8(SHDN)             | D3 | D2 |                  | D8(SHDN)             | D6 | D7 |                  |
| 1                    | 0  | 0  | 0 V              | 1                    | 0  | 0  | 0 V              |
| 1                    | 0  | 1  | 3.3 V            | 1                    | 0  | 1  | 3.3 V            |
| 1                    | 1  | 0  | 5 V              | 1                    | 1  | 0  | 5 V              |
| 1                    | 1  | 1  | 0 V              | 1                    | 1  | 1  | 0 V              |
| 0                    | X  | X  | Hi-Z             | 0                    | X  | X  | Hi-Z             |

**Table 3–4. TPS2226 Control Logic—xVPP**

| AVPP CONTROL SIGNALS |    |    |    | OUTPUT<br>V_AVPP | BVPP CONTROL SIGNALS |    |    |     | OUTPUT<br>V_BVPP |
|----------------------|----|----|----|------------------|----------------------|----|----|-----|------------------|
| D8(SHDN)             | D0 | D1 | D9 |                  | D8(SHDN)             | D4 | D5 | D10 |                  |
| 1                    | 0  | 0  | X  | 0 V              | 1                    | 0  | 0  | X   | 0 V              |
| 1                    | 0  | 1  | 0  | 3.3 V            | 1                    | 0  | 1  | 0   | 3.3 V            |
| 1                    | 0  | 1  | 1  | 5 V              | 1                    | 0  | 1  | 1   | 5 V              |
| 1                    | 1  | 0  | X  | 12 V             | 1                    | 1  | 0  | X   | 12 V             |
| 1                    | 1  | 1  | X  | Hi-Z             | 1                    | 1  | 1  | X   | Hi-Z             |
| 0                    | X  | X  | X  | Hi-Z             | 0                    | X  | X  | X   | Hi-Z             |

**Table 3–5. TPS2226 Control Logic—xVCC**

| AVCC CONTROL SIGNALS |    |    | OUTPUT<br>V_AVCC | BVCC CONTROL SIGNALS |    |    | OUTPUT<br>V_BVCC |
|----------------------|----|----|------------------|----------------------|----|----|------------------|
| D8(SHDN)             | D3 | D2 |                  | D8(SHDN)             | D6 | D7 |                  |
| 1                    | 0  | 0  | 0 V              | 1                    | 0  | 0  | 0 V              |
| 1                    | 0  | 1  | 3.3 V            | 1                    | 0  | 1  | 3.3 V            |
| 1                    | 1  | 0  | 5 V              | 1                    | 1  | 0  | 5 V              |
| 1                    | 1  | 1  | 0 V              | 1                    | 1  | 1  | 0 V              |
| 0                    | X  | X  | Hi-Z             | 0                    | X  | X  | Hi-Z             |

### 3.6.6 Internal Ring Oscillator

The internal ring oscillator provides an internal clock source for the PCI6x20 device so that neither the PCI clock nor an external clock is required in order for the PCI6x20 device to power down a socket or interrogate a PC Card. This internal oscillator, operating nominally at 16 kHz, is always enabled.

### 3.6.7 Integrated Pullup Resistors for PC Card Interface

The *PC Card Standard* requires pullup resistors on various terminals to support both CardBus and 16-bit PC Card configurations. The PCI6x20 device has integrated all of these pullup resistors and requires no additional external components. The I/O buffer on the BVD1(STSCHG)/CSTSCHG terminal has the capability to switch to an internal pullup resistor when a 16-bit PC Card is inserted, or switch to an internal pulldown resistor when a CardBus card is inserted. This prevents inadvertent CSTSCHG events. The pullup resistor requirements for the various UltraMedia interfaces are either included in the UltraMedia cards (or the UltraMedia adapter) or are part of the existing PCMCIA architecture. The PCI6x20 device does not require any additional components for UltraMedia support.

### 3.6.8 SPKROUT and CAUDPWM Usage

The SPKROUT terminal carries the digital audio signal from the PC Card to the system. When a 16-bit PC Card is configured for I/O mode, the BVD2 terminal becomes the SPKR input terminal from the card. This terminal, in CardBus applications, is referred to as CAUDIO. SPKR passes a TTL-level binary audio signal to the PCI6x20 device. The CardBus CAUDIO signal also can pass a single-amplitude binary waveform as well as a PWM signal. The binary audio signal from each PC Card sockets is enabled by bit 1 (SPKROUTEN) of the card control register (PCI offset 91h, see Section 4.38).

Older controllers support CAUDIO in binary or PWM mode, but use the same output terminal (SPKROUT). Some audio chips may not support both modes on one terminal and may have a separate terminal for binary and PWM. The PCI6x20 implementation includes a signal for PWM, CAUDPWM, which can be routed to an MFUNC terminal. Bit 2 (AUD2MUX), located in the card control register, is programmed to route a CardBus CAUDIO PWM terminal to CAUDPWM. See Section 4.36, *Multifunction Routing Register*, for details on configuring the MFUNC terminals.

Figure 3–4 illustrates the SPKROUT connection.

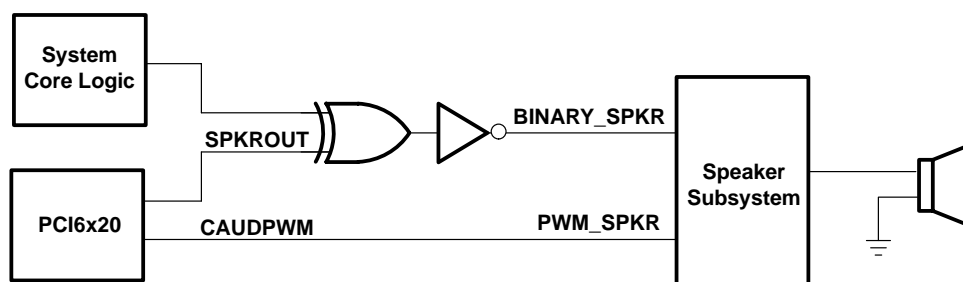

Figure 3–4. SPKROUT Connection to Speaker Driver

### 3.6.9 LED Socket Activity Indicators

The socket activity LEDs are provided to indicate when a PC Card is being accessed. The LEDA1 and LEDA2 signals can be routed to the multifunction terminals. When configured for LED output, these terminals output an active high signal to indicate socket activity. LEDA1 indicates socket A (card A) activity, and LEDA2 indicates socket B (card B) activity. The LED\_SKT output indicates socket activity to either socket A or socket B. See Section 4.36, *Multifunction Routing Status Register*, for details on configuring the multifunction terminals.

The active-high LED signal is driven for 64 ms. When the LED is not being driven high, it is driven to a low state. Either of the two circuits shown in Figure 3–5 can be implemented to provide LED signaling, and the board designer must implement the circuit that best fits the application.

The LED activity signals are valid when a card is inserted, powered, and not in reset. For PC Card-16, the LED activity signals are pulsed when  $\overline{\text{READY}}(\overline{\text{IREQ}})$  is low. For CardBus cards, the LED activity signals are pulsed if  $\overline{\text{CFRAME}}$ ,  $\overline{\text{IRDY}}$ , or  $\overline{\text{CREQ}}$  are active.

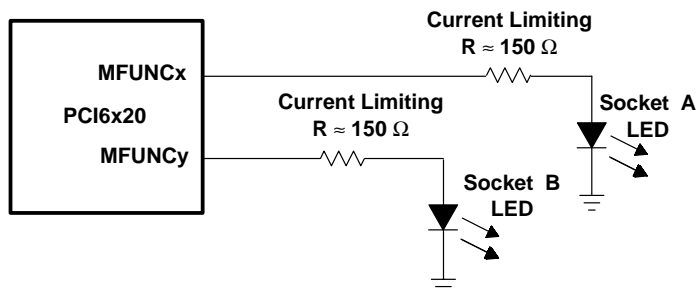

**Figure 3–5. Two Sample LED Circuits**

As indicated, the LED signals are driven for a period of 64 ms by a counter circuit. To avoid the possibility of the LEDs appearing to be stuck when the PCI clock is stopped, the LED signaling is cut off when the  $\overline{\text{SUSPEND}}$  signal is asserted, when the PCI clock is to be stopped during the clock run protocol, or when in the D2 or D1 power state.

If any additional socket activity occurs during this counter cycle, then the counter is reset and the LED signal remains driven. If socket activity is frequent (at least once every 64 ms), then the LED signals remain driven.

### 3.6.10 CardBus Socket Registers

The PCI6x20 device contains all registers for compatibility with the *PCI Local Bus Specification* and the *PC Card Standard*. These registers, which exist as the CardBus socket registers, are listed in Table 3–6.

**Table 3–6. CardBus Socket Registers**

| REGISTER NAME           | OFFSET  |
|-------------------------|---------|
| Socket event            | 00h     |
| Socket mask             | 04h     |
| Socket present state    | 08h     |
| Socket force event      | 0Ch     |
| Socket control          | 10h     |
| Reserved                | 14h–1Ch |
| Socket power management | 20h     |

### 3.6.11 48-MHz Clock Requirements

The PCI6x20 device is designed to use an external 48-MHz clock connected to the CLK\_48 terminal to provide the reference for an internal oscillator circuit. This oscillator in turn drives a PLL circuit that generates the various clocks required for the flash media function (Function 3) of the PCI6x20 device.

The 48-MHz clock must maintain a frequency of 48 MHz  $\pm$  0.8% over normal operating conditions. This clock must maintain a duty cycle of 40% – 60%. The PCI6x20 device requires that the 48-MHz clock be running and stable (a minimum of 10 clock pulses) before a  $\overline{\text{GRST}}$  deassertion.

The following are typical specifications for crystals used with the PCI6x20 device in order to achieve the required frequency accuracy and stability.

- Crystal mode of operation: Fundamental
- Frequency tolerance @ 25°C: Total frequency variation for the complete circuit is  $\pm$ 100 ppm. A crystal with  $\pm$ 30 ppm frequency tolerance is recommended for adequate margin.
- Frequency stability (over temperature and age): A crystal with  $\pm$ 30 ppm frequency stability is recommended for adequate margin.

**NOTE:** The total frequency variation must be kept below  $\pm 100$  ppm from nominal with some allowance for error introduced by board and device variations. Trade-offs between frequency tolerance and stability may be made as long as the total frequency variation is less than  $\pm 100$  ppm. For example, the frequency tolerance of the crystal may be specified at 50 ppm and the temperature tolerance may be specified at 30 ppm to give a total of 80 ppm possible variation due to the crystal alone. Crystal aging also contributes to the frequency variation.

### 3.7 Serial EEPROM Interface

The PCI6x20 device has a dedicated serial bus interface that can be used with an EEPROM to load certain registers in the PCI6x20 device. The EEPROM is detected by a pullup resistor on the SCL terminal. See Table 3–8 for the EEPROM loading map.

#### 3.7.1 Serial-Bus Interface Implementation

The PCI6x20 device drives SCL at nearly 100 kHz during data transfers, which is the maximum specified frequency for standard mode I<sup>2</sup>C. The serial EEPROM must be located at address A0h.

Some serial device applications may include PC Card power switches, card ejectors, or other devices that may enhance the user's PC Card experience. The serial EEPROM device and PC Card power switches are discussed in the sections that follow.

#### 3.7.2 Accessing Serial-Bus Devices Through Software

The PCI6x20 device provides a programming mechanism to control serial bus devices through software. The programming is accomplished through a doubleword of PCI configuration space at offset B0h. Table 3–7 lists the registers used to program a serial-bus device through software.

**Table 3–7. PCI6x20 Registers Used to Program Serial-Bus Devices**

| PCI OFFSET | REGISTER NAME                 | DESCRIPTION   |
|------------|-------------------------------|---|
| B0h        | Serial-bus data               | Contains the data byte to send on write commands or the received data byte on read commands.  |
| B1h        | Serial-bus index              | The content of this register is sent as the word address on byte writes or reads. This register is not used in the quick command protocol.                                |
| B2h        | Serial-bus slave address      | Write transactions to this register initiate a serial-bus transaction. The slave device address and the R/W command selector are programmed through this register.        |
| B3h        | Serial-bus control and status | Read data valid, general busy, and general error status are communicated through this register. In addition, the protocol-select bit is programmed through this register. |

#### 3.7.3 Serial-Bus Interface Protocol

The SCL and SDA signals are bidirectional, open-drain signals and require pullup resistors as shown in Figure 3–3. The PCI6x20 device, which supports up to 100-Kb/s data-transfer rate, is compatible with standard mode I<sup>2</sup>C using 7-bit addressing.

All data transfers are initiated by the serial bus master. The beginning of a data transfer is indicated by a start condition, which is signaled when the SDA line transitions to the low state while SCL is in the high state, as shown in Figure 3–6. The end of a requested data transfer is indicated by a stop condition, which is signaled by a low-to-high transition of SDA while SCL is in the high state, as shown in Figure 3–6. Data on SDA must remain stable during the high state of the SCL signal, as changes on the SDA signal during the high state of SCL are interpreted as control signals, that is, a start or a stop condition.

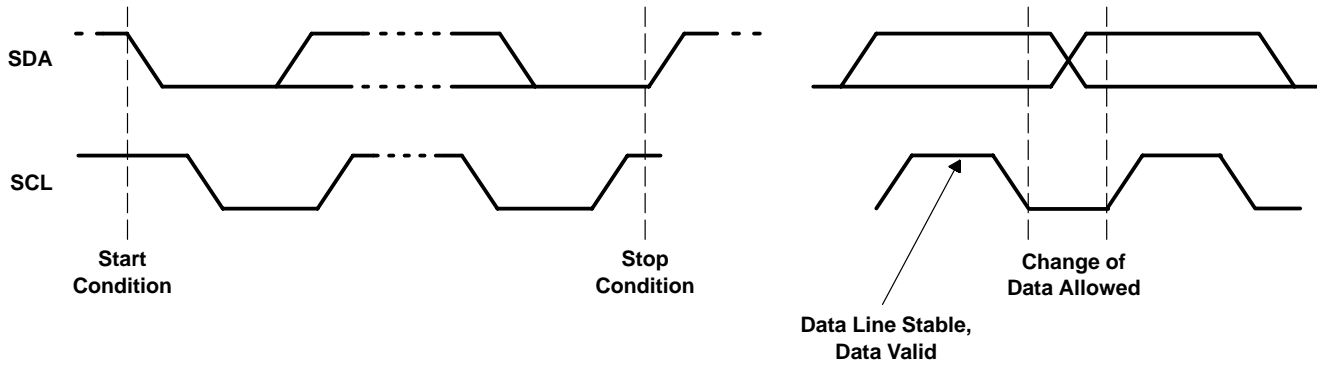

**Figure 3–6. Serial-Bus Start/Stop Conditions and Bit Transfers**

Data is transferred serially in 8-bit bytes. The number of bytes that may be transmitted during a data transfer is unlimited; however, each byte must be completed with an acknowledge bit. An acknowledge (ACK) is indicated by the receiver pulling the SDA signal low, so that it remains low during the high state of the SCL signal. Figure 3–7 illustrates the acknowledge protocol.

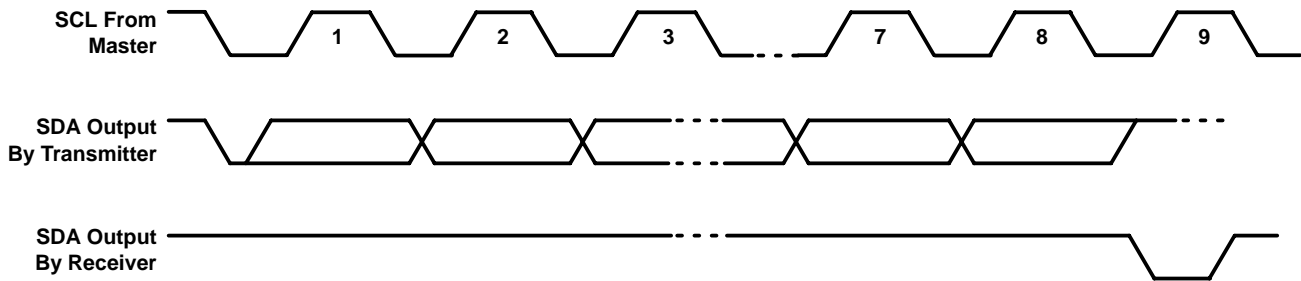
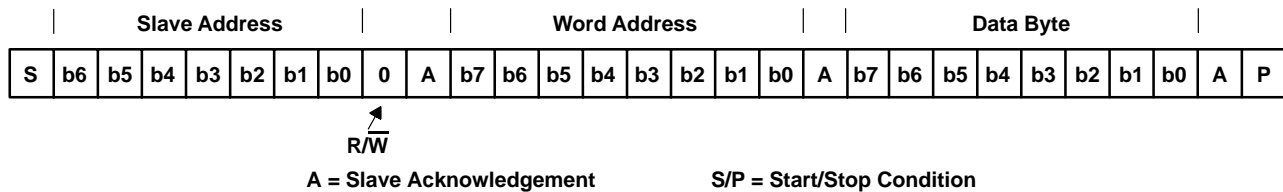

**Figure 3–7. Serial-Bus Protocol Acknowledge**

The PCI6x20 device is a serial bus master; all other devices connected to the serial bus external to the PCI6x20 device are slave devices. As the bus master, the PCI6x20 device drives the SCL clock at nearly 100 kHz during bus cycles and places SCL in a high-impedance state (zero frequency) during idle states.

Typically, the PCI6x20 device masters byte reads and byte writes under software control. Doubleword reads are performed by the serial EEPROM initialization circuitry upon a PCI reset and may not be generated under software control. See Section 3.7.4, *Serial-Bus EEPROM Application*, for details on how the PCI6x20 device automatically loads the subsystem identification and other register defaults through a serial-bus EEPROM.

Figure 3–8 illustrates a byte write. The PCI6x20 device issues a start condition and sends the 7-bit slave device address and the command bit zero. A 0 in the R/W command bit indicates that the data transfer is a write. The slave device acknowledges if it recognizes the address. If no acknowledgment is received by the PCI6x20 device, then an appropriate status bit is set in the serial-bus control/status register (PCI offset B3h, see Section 4.50). The word address byte is then sent by the PCI6x20 device, and another slave acknowledgment is expected. Then the PCI6x20 device delivers the data byte MSB first and expects a final acknowledgment before issuing the stop condition.



**Figure 3–8. Serial-Bus Protocol—Byte Write**

Figure 3–9 illustrates a byte read. The read protocol is very similar to the write protocol, except the R/W command bit must be set to 1 to indicate a read-data transfer. In addition, the PCI6x20 master must acknowledge reception of

the read bytes from the slave transmitter. The slave transmitter drives the SDA signal during read data transfers. The SCL signal remains driven by the PCI6x20 master.

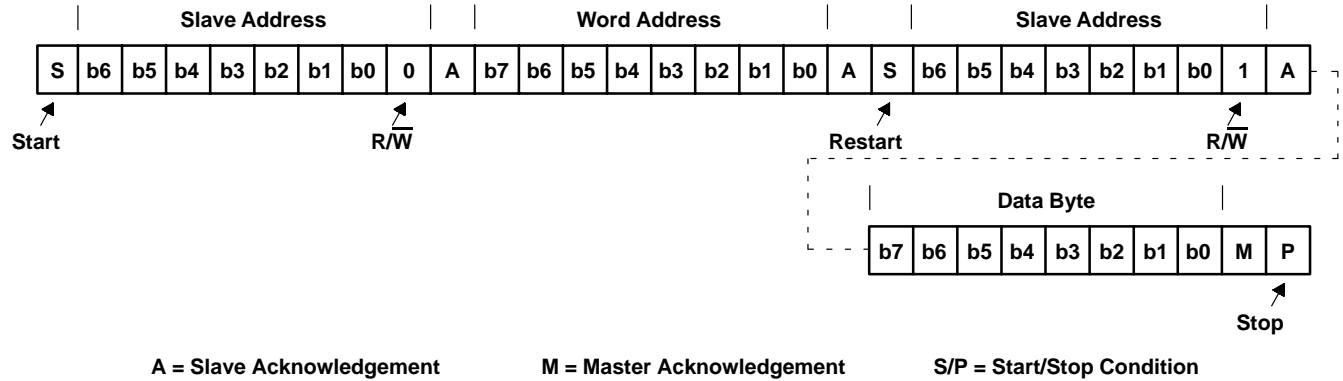

**Figure 3-9. Serial-Bus Protocol—Byte Read**

Figure 3-10 illustrates EEPROM interface doubleword data collection protocol.

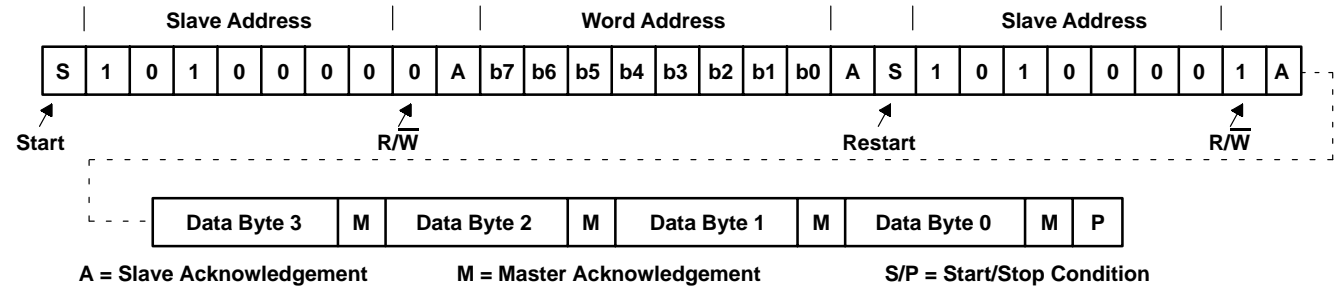

**Figure 3-10. EEPROM Interface Doubleword Data Collection**

### 3.7.4 Serial-Bus EEPROM Application

When the PCI bus is reset and the serial-bus interface is detected, the PCI6x20 device attempts to read the subsystem identification and other register defaults from a serial EEPROM.

This format must be followed for the PCI6x20 device to load initializations from a serial EEPROM. All bit fields must be considered when programming the EEPROM.

The serial EEPROM is addressed at slave address 1010 000b by the PCI6x20 device. All hardware address bits for the EEPROM must be tied to the appropriate level to achieve this address. The serial EEPROM chip in the sample application (Figure 3-10) assumes the 1010b high-address nibble. The lower three address bits are terminal inputs to the chip, and the sample application shows these terminal inputs tied to GND.

**Table 3–8. EEPROM Loading Map**

| SERIAL ROM OFFSET | BYTE DESCRIPTION  |                                |                                |                                  |                                |                                |                                |
|-------------------|---|--------------------------------|--------------------------------|----------------------------------|--------------------------------|--------------------------------|--------------------------------|
| 00h               | CardBus function indicator (00h)  |                                |                                |                                  |                                |                                |                                |
| 01h               | Number of bytes (20h)   |                                |                                |                                  |                                |                                |                                |
| 02h               | PCI 04h, command register, function 0, bits 8, 6–5, 2–0   |                                |                                |                                  |                                |                                |                                |
|                   | [7]<br>Command register, bit 8  | [6]<br>Command register, bit 6 | [5]<br>Command register, bit 5 | [4:3]<br>RSVD                    | [2]<br>Command register, bit 2 | [1]<br>Command register, bit 1 | [0]<br>Command register, bit 0 |
| 03h               | PCI 04h, command register, function 1, bits 8, 6–5, 2–0   |                                |                                |                                  |                                |                                |                                |
|                   | [7]<br>Command register, bit 8  | [6]<br>Command register, bit 6 | [5]<br>Command register, bit 5 | [4:3]<br>RSVD                    | [2]<br>Command register, bit 2 | [1]<br>Command register, bit 1 | [0]<br>Command register, bit 0 |
| 04h               | PCI 40h, subsystem vendor ID, byte 0  |                                |                                |                                  |                                |                                |                                |
| 05h               | PCI 41h, subsystem vendor ID, byte 1  |                                |                                |                                  |                                |                                |                                |
| 06h               | PCI 42h, subsystem ID, byte 0   |                                |                                |                                  |                                |                                |                                |
| 07h               | PCI 43h, subsystem ID, byte 1   |                                |                                |                                  |                                |                                |                                |
| 08h               | PCI 44h, PC Card 16-bit I/F legacy mode base address register, byte 0, bits 7–1                               |                                |                                |                                  |                                |                                |                                |
| 09h               | PCI 45h, PC Card 16-bit I/F legacy mode base address register, byte 1   |                                |                                |                                  |                                |                                |                                |
| 0Ah               | PCI 46h, PC Card 16-bit I/F legacy mode base address register, byte 2   |                                |                                |                                  |                                |                                |                                |
| 0Bh               | PCI 47h, PC Card 16-bit I/F legacy mode base address register, byte 3   |                                |                                |                                  |                                |                                |                                |
| 0Ch               | PCI 80h, system control, function 0, byte 0, bits 6–0   |                                |                                |                                  |                                |                                |                                |
| 0Dh               | PCI 80h, system control, function 1, byte 0, bit 2  |                                |                                |                                  |                                |                                |                                |
| 0Eh               | PCI 81h, system control, byte 1   |                                |                                |                                  |                                |                                |                                |
| 0Fh               | Reserved load all 0s (PCI 82h, system control, byte 2)  |                                |                                |                                  |                                |                                |                                |
| 10h               | PCI 83h, system control, byte 3   |                                |                                |                                  |                                |                                |                                |
| 11h               | PCI 8Ch, MFUNC routing, byte 0  |                                |                                |                                  |                                |                                |                                |
| 12h               | PCI 8Dh, MFUNC routing, byte 1  |                                |                                |                                  |                                |                                |                                |
| 13h               | PCI 8Eh, MFUNC routing, byte 2  |                                |                                |                                  |                                |                                |                                |
| 14h               | PCI 8Fh, MFUNC routing, byte 3  |                                |                                |                                  |                                |                                |                                |
| 15h               | PCI 90h, retry status, bits 7, 6  |                                |                                |                                  |                                |                                |                                |
| 16h               | PCI 91h, card control, bit 7  |                                |                                |                                  |                                |                                |                                |
| 17h               | PCI 92h, device control, bits 6, 5, 3–0   |                                |                                |                                  |                                |                                |                                |
| 18h               | PCI 93h, diagnostic, bits 7, 4–0  |                                |                                |                                  |                                |                                |                                |
| 19h               | PCI A2h, power-management capabilities, function 0, bit 15 (bit 7 of EEPROM offset 16h corresponds to bit 15) |                                |                                |                                  |                                |                                |                                |
| 1Ah               | PCI A2h, power-management capabilities, function 1, bit 15 (bit 7 of EEPROM offset 16h corresponds to bit 15) |                                |                                |                                  |                                |                                |                                |
| 1Bh               | CB Socket + 0Ch, function 0 socket force event, bit 27 (bit 3 of EEPROM offset 17h corresponds to bit 27)     |                                |                                |                                  |                                |                                |                                |
| 1Ch               | CB Socket + 0Ch, function 1 socket force event, bit 27 (bit 3 of EEPROM offset 18h corresponds to bit 27)     |                                |                                |                                  |                                |                                |                                |
| 1Dh               | ExCA 00h, ExCA identification and revision, bits 7–0  |                                |                                |                                  |                                |                                |                                |
| 1Eh               | PCI 86h, general control, byte 0, bits 5, 4, 3, 1, 0  |                                |                                |                                  |                                |                                |                                |
| 1Fh               | PCI 87h, general control, byte 1, bits 4–2  |                                |                                |                                  |                                |                                |                                |
| 20h               | PCI 89h, $\overline{\text{GPE}}$ enable, bits 7, 6, 4–0   |                                |                                |                                  |                                |                                |                                |
| 21h               | PCI 8Bh, general-purpose output, bits 4–0   |                                |                                |                                  |                                |                                |                                |
| 22h               | Reserved  |                                |                                |                                  |                                |                                |                                |
| 23h               | Number of bytes (17h)   |                                |                                |                                  |                                |                                |                                |
| 24h               | PCI 3Fh, maximum latency bits 7–4   |                                |                                | PCI 3Eh, minimum grant, bits 3–0 |                                |                                |                                |

**Table 3–8. EEPROM Loading Map (Continued)**

| SERIAL ROM OFFSET | BYTE DESCRIPTION   |
|-------------------|--|
| 25h               | PCI 2Ch, subsystem vendor ID, byte 0   |
| 26h               | PCI 2Dh, subsystem vendor ID, byte 1   |
| 27h               | PCI 2Eh, subsystem ID, byte 0  |
| 28h               | PCI 2Fh, subsystem ID, byte 1  |
| 29h               | Reserved   |
| 2Ah               | Mini-ROM address, this byte indicates the MINI ROM offset into the EEPROM<br>00h = No MINI ROM<br>Other Values = MINI ROM offset |
| 2Bh               | Reserved   |
| 2Ch               | Reserved   |
| 2Dh               | Reserved   |
| 2Eh               | Reserved   |
| 2Fh               | Reserved   |
| 30h               | Reserved   |
| 31h               | Reserved   |
| 32h               | Reserved   |
| 33h               | Checksum (Reserved—no bit loaded)  |
| 34h               | Reserved   |
| 35h               | PCI F0h, PCI miscellaneous, byte 0, bits 5, 4, 2, 1, 0   |
| 36h               | PCI F1h, PCI miscellaneous, byte 1, bits 7, 3, 2, 1, 0   |
| 37h               | Reserved   |
| 38h               | Reserved (CardBus CIS pointer)   |
| 39h               | Reserved   |
| 3Ah               | Reserved   |
| 3Bh               | Flash media core function indicator (03h)  |
| 3Ch               | Number of bytes (05h)  |
| 3Dh               | PCI 2Ch, subsystem vendor ID, byte 0   |
| 3Eh               | PCI 2Dh, subsystem vendor ID, byte 1   |
| 3Fh               | PCI 2Eh, subsystem ID, byte 0  |
| 40h               | PCI 2Fh, subsystem ID, byte 1  |
| 41h               | PCI 4Ch, miscellaneous control, bits 6–0   |
| 42h               | End-of-list indicator (80h)  |

### 3.8 Programmable Interrupt Subsystem

Interrupts provide a way for I/O devices to let the microprocessor know that they require servicing. The dynamic nature of PC Cards and the abundance of PC Card I/O applications require substantial interrupt support from the PCI6x20 device. The PCI6x20 device provides several interrupt signaling schemes to accommodate the needs of a variety of platforms. The different mechanisms for dealing with interrupts in this device are based on various specifications and industry standards. The ExCA register set provides interrupt control for some 16-bit PC Card functions, and the CardBus socket register set provides interrupt control for the CardBus PC Card functions. The PCI6x20 device is, therefore, backward compatible with existing interrupt control register definitions, and new registers have been defined where required.

The PCI6x20 device detects PC Card interrupts and events at the PC Card interface and notifies the host controller using one of several interrupt signaling protocols. To simplify the discussion of interrupts in the PCI6x20 device, PC Card interrupts are classified either as card status change (CSC) or as functional interrupts.

The method by which any type of PCI6x20 interrupt is communicated to the host interrupt controller varies from system to system. The PCI6x20 device offers system designers the choice of using parallel PCI interrupt signaling, parallel ISA-type IRQ interrupt signaling, or the IRQSER serialized ISA and/or PCI interrupt protocol. It is possible to use the parallel PCI interrupts in combination with either parallel IRQs or serialized IRQs, as detailed in the sections that follow. All interrupt signaling is provided through the seven multifunction terminals, MFUNC0–MFUNC6.

### 3.8.1 PC Card Functional and Card Status Change Interrupts

PC Card functional interrupts are defined as requests from a PC Card application for interrupt service and are indicated by asserting specially-defined signals on the PC Card interface. Functional interrupts are generated by 16-bit I/O PC Cards and by CardBus PC Cards.

Card status change (CSC)-type interrupts are defined as events at the PC Card interface that are detected by the PCI6x20 device and may warrant notification of host card and socket services software for service. CSC events include both card insertion and removal from PC Card sockets, as well as transitions of certain PC Card signals.

Table 3–9 summarizes the sources of PC Card interrupts and the type of card associated with them. CSC and functional interrupt sources are dependent on the type of card inserted in the PC Card socket. The four types of cards that can be inserted into any PC Card socket are:

- 16-bit memory card
- 16-bit I/O card
- CardBus cards
- UltraMedia card

**Table 3–9. Interrupt Mask and Flag Registers**

| CARD TYPE  | EVENT  | MASK                                  | FLAG                                  |
|--|--|---------------------------------------|---------------------------------------|
| 16-bit memory  | Battery conditions (BVD1, BVD2)                      | ExCA offset 05h/45h/805h bits 1 and 0 | ExCA offset 04h/44h/804h bits 1 and 0 |
|  | Wait states (READY)                                  | ExCA offset 05h/45h/805h bit 2        | ExCA offset 04h/44h/804h bit 2        |
| 16-bit I/O   | Change in card status ( $\overline{\text{STSCHG}}$ ) | ExCA offset 05h/45h/805h bit 0        | ExCA offset 04h/44h/804h bit 0        |
| 16-bit I/O/<br>UltraMedia  | Interrupt request ( $\overline{\text{IREQ}}$ )       | Always enabled                        | PCI configuration offset 91h bit 0    |
| All 16-bit PC<br>Cards/<br>Smart Card<br>adapters/<br>UltraMedia/<br>Flash Media | Power cycle complete                                 | ExCA offset 05h/45h/805h bit 3        | ExCA offset 04h/44h/804h bit 3        |
| CardBus  | Change in card status (CSTSCHG)                      | Socket mask bit 0                     | Socket event bit 0                    |
|  | Interrupt request ( $\overline{\text{CINT}}$ )       | Always enabled                        | PCI configuration offset 91h bit 0    |
|  | Power cycle complete                                 | Socket mask bit 3                     | Socket event bit 3                    |
|  | Card insertion or removal                            | Socket mask bits 2 and 1              | Socket event bits 2 and 1             |

Functional interrupt events are valid only for 16-bit I/O and CardBus cards; that is, the functional interrupts are not valid for 16-bit memory cards. Furthermore, card insertion and removal-type CSC interrupts are independent of the card type.

**Table 3–10. PC Card Interrupt Events and Description**

| CARD TYPE  | EVENT  | TYPE       | SIGNAL   | DESCRIPTION   |
|--|--|------------|--|---|
| 16-bit memory  | Battery conditions (BVD1, BVD2)                      | CSC        | BVD1( $\overline{\text{STSCHG}}$ )/CSTSCHG   | A transition on BVD1 indicates a change in the PC Card battery conditions.  |
|  |  |            | BVD2( $\overline{\text{SPKR}}$ )/CAUDIO  | A transition on BVD2 indicates a change in the PC Card battery conditions.  |
|  | Wait states (READY)                                  | CSC        | READY( $\overline{\text{IREQ}}$ )/ $\overline{\text{CINT}}$  | A transition on READY indicates a change in the ability of the memory PC Card to accept or provide data.  |
| 16-bit I/O   | Change in card status ( $\overline{\text{STSCHG}}$ ) | CSC        | BVD1( $\overline{\text{STSCHG}}$ )/CSTSCHG   | The assertion of $\overline{\text{STSCHG}}$ indicates a status change on the PC Card.   |
| 16-bit I/O/ UltraMedia                                     | Interrupt request ( $\overline{\text{IREQ}}$ )       | Functional | READY( $\overline{\text{IREQ}}$ )/ $\overline{\text{CINT}}$  | The assertion of $\overline{\text{IREQ}}$ indicates an interrupt request from the PC Card.  |
| CardBus  | Change in card status (CSTSCHG)                      | CSC        | BVD1( $\overline{\text{STSCHG}}$ )/CSTSCHG   | The assertion of CSTSCHG indicates a status change on the PC Card.  |
|  | Interrupt request ( $\overline{\text{CINT}}$ )       | Functional | READY( $\overline{\text{IREQ}}$ )/ $\overline{\text{CINT}}$  | The assertion of $\overline{\text{CINT}}$ indicates an interrupt request from the PC Card.  |
| All PC Cards/ Smart Card adapters/ UltraMedia/ Flash Media | Card insertion or removal                            | CSC        | $\overline{\text{CD1}}//\overline{\text{CCD1}}$ ,<br>$\overline{\text{CD2}}//\overline{\text{CCD2}}$ | A transition on either $\overline{\text{CD1}}//\overline{\text{CCD1}}$ or $\overline{\text{CD2}}//\overline{\text{CCD2}}$ indicates an insertion or removal of a 16-bit or CardBus PC Card. |
|  | Power cycle complete                                 | CSC        | N/A  | An interrupt is generated when a PC Card power-up cycle has completed.  |

The naming convention for PC Card signals describes the function for 16-bit memory, I/O cards, and CardBus. For example,  $\text{READY}(\overline{\text{IREQ}})//\overline{\text{CINT}}$  includes READY for 16-bit memory cards,  $\overline{\text{IREQ}}$  for 16-bit I/O cards, and  $\overline{\text{CINT}}$  for CardBus cards. The 16-bit memory card signal name is first, with the I/O card signal name second, enclosed in parentheses. The CardBus signal name follows after a double slash (/).

The *1997 PC Card Standard* describes the power-up sequence that must be followed by the PCI6x20 device when an insertion event occurs and the host requests that the socket  $V_{CC}$  and  $V_{PP}$  be powered. Upon completion of this power-up sequence, the PCI6x20 interrupt scheme can be used to notify the host system (see Table 3–10), denoted by the power cycle complete event. This interrupt source is considered a PCI6x20 internal event, because it depends on the completion of applying power to the socket rather than on a signal change at the PC Card interface.

### 3.8.2 Interrupt Masks and Flags

Host software may individually mask (or disable) most of the potential interrupt sources listed in Table 3–10 by setting the appropriate bits in the PCI6x20 device. By individually masking the interrupt sources listed, software can control those events that cause a PCI6x20 interrupt. Host software has some control over the system interrupt the PCI6x20 device asserts by programming the appropriate routing registers. The PCI6x20 device allows host software to route PC Card CSC and PC Card functional interrupts to separate system interrupts. Interrupt routing somewhat specific to the interrupt signaling method used is discussed in more detail in the following sections.

When an interrupt is signaled by the PCI6x20 device, the interrupt service routine must determine which of the events listed in Table 3–9 caused the interrupt. Internal registers in the PCI6x20 device provide flags that report the source of an interrupt. By reading these status bits, the interrupt service routine can determine the action to be taken.

Table 3–9 details the registers and bits associated with masking and reporting potential interrupts. All interrupts can be masked except the functional PC Card interrupts, and an interrupt status flag is available for all types of interrupts.

Notice that there is not a mask bit to stop the PCI6x20 device from passing PC Card functional interrupts through to the appropriate interrupt scheme. These interrupts are not valid until the card is properly powered, and there must never be a card interrupt that does not require service after proper initialization.

Table 3–9 lists the various methods of clearing the interrupt flag bits. The flag bits in the ExCA registers (16-bit PC Card-related interrupt flags) can be cleared using two different methods. One method is an explicit write of 1 to the flag bit to clear and the other is by reading the flag bit register. The selection of flag bit clearing methods is made by

bit 2 (IFCMODE) in the ExCA global control register (ExCA offset 1Eh/5Eh/81Eh, see Section 5.20), and defaults to the flag-cleared-on-read method.

The CardBus-related interrupt flags can be cleared by an explicit write of 1 to the interrupt flag in the socket event register (see Section 6.1). Although some of the functionality is shared between the CardBus registers and the ExCA registers, software must not program the chip through both register sets when a CardBus card is functioning.

### 3.8.3 Using Parallel IRQ Interrupts

The seven multifunction terminals, MFUNC6–MFUNC0, implemented in the PCI6x20 device can be routed to obtain a subset of the ISA IRQs. The IRQ choices provide ultimate flexibility in PC Card host interruptions. To use the parallel ISA-type IRQ interrupt signaling, software must program the device control register (PCI offset 92h, see Section 4.39), to select the parallel IRQ signaling scheme. See Section 4.36, *Multifunction Routing Status Register*, for details on configuring the multifunction terminals.

A system using parallel IRQs requires (at a minimum) one PCI terminal,  $\overline{\text{INTA}}$ , to signal CSC events. This requirement is dictated by certain card and socket-services software. The  $\overline{\text{INTA}}$  requirement calls for routing the MFUNC0 terminal for  $\overline{\text{INTA}}$  signaling. The INTRTIE bit is used, in this case, to route socket interrupt events to  $\overline{\text{INTA}}$ . This leaves (at a maximum) six different IRQs to support legacy 16-bit PC Card functions.

As an example, suppose the six IRQs used by legacy PC Card applications are IRQ3, IRQ4, IRQ5, IRQ10, IRQ11, and IRQ15. The multifunction routing status register must be programmed to a value of 0FBA 5432h. This value routes the MFUNC0 terminal to  $\overline{\text{INTA}}$  signaling and routes the remaining terminals as illustrated in Figure 3–11. Not shown is that  $\overline{\text{INTA}}$  must also be routed to the programmable interrupt controller (PIC), or to some circuitry that provides parallel PCI interrupts to the host.

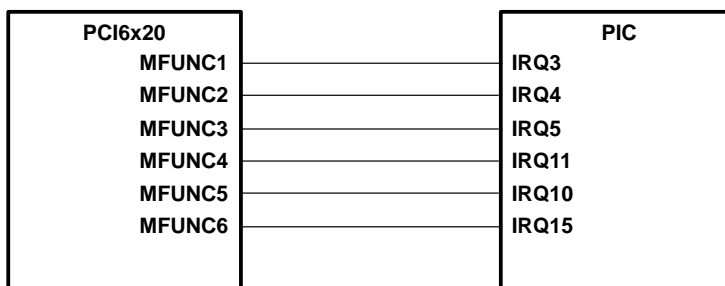

Figure 3–11. IRQ Implementation

Power-on software is responsible for programming the multifunction routing status register to reflect the IRQ configuration of a system implementing the PCI6x20 device. The multifunction routing status register is a global register that is shared between the three PCI6x20 functions. See Section 4.36, *Multifunction Routing Status Register*, for details on configuring the multifunction terminals.

The parallel ISA-type IRQ signaling from the MFUNC6–MFUNC0 terminals is compatible with the input signal requirements of the 8259 PIC. The parallel IRQ option is provided for system designs that require legacy ISA IRQs. Design constraints may demand more MFUNC6–MFUNC0 IRQ terminals than the PCI6x20 device makes available.

### 3.8.4 Using Parallel PCI Interrupts

Parallel PCI interrupts are available when exclusively in parallel PCI interrupt/parallel ISA IRQ signaling mode, and when only IRQs are serialized with the IRQSER protocol. The  $\overline{\text{INTA}}$ ,  $\overline{\text{INTB}}$ ,  $\overline{\text{INTC}}$ , and  $\overline{\text{INTD}}$  can be routed to MFUNC terminals (MFUNC0, MFUNC1, MFUNC2, and MFUNC4). If bit 29 (INTRTIE) is set in the system control register (PCI offset 80h, see Section 4.29), then  $\overline{\text{INTA}}$  and  $\overline{\text{INTB}}$  are tied internally. When the TIEALL bit is set, all three functions return a value of 01h on reads from the interrupt pin register for both parallel and serial PCI interrupts.

The INTRTIE and TIEALL bits affect the read-only value provided through accesses to the interrupt pin register (PCI offset 3Dh, see Section 4.24). Table 3–11 summarizes the interrupt signaling modes.

**Table 3–11. Interrupt Pin Register Cross Reference**

| INTRTIE Bit | TIEALL Bit | INTPIN<br>Function 0<br>(CardBus) | INTPIN<br>Function 1<br>(CardBus) | INTPIN<br>Function 3<br>(Flash Media)   |
|-------------|------------|-----------------------------------|-----------------------------------|---|
| 0           | 0          | 0x01 ( $\overline{\text{INTA}}$ ) | 0x02 ( $\overline{\text{INTB}}$ ) | Determined by bits 6–5 (INT_SEL field) in flash media general control register (see Section 7.21) |
| 1           | 0          | 0x01 ( $\overline{\text{INTA}}$ ) | 0x01 ( $\overline{\text{INTA}}$ ) |   |
| X           | 1          | 0x01 ( $\overline{\text{INTA}}$ ) | 0x01 ( $\overline{\text{INTA}}$ ) | 0x01 ( $\overline{\text{INTA}}$ )   |

### 3.8.5 Using Serialized IRQSER Interrupts

The serialized interrupt protocol implemented in the PCI6x20 device uses a single terminal to communicate all interrupt status information to the host controller. The protocol defines a serial packet consisting of a start cycle, multiple interrupt indication cycles, and a stop cycle. All data in the packet is synchronous with the PCI clock. The packet data describes 16 parallel ISA IRQ signals and the optional 4 PCI interrupts  $\overline{\text{INTA}}$ ,  $\overline{\text{INTB}}$ ,  $\overline{\text{INTC}}$ , and  $\overline{\text{INTD}}$ . For details on the IRQSER protocol, refer to the document *Serialized IRQ Support for PCI Systems*.

### 3.8.6 SMI Support in the PCI6x20 Device

The PCI6x20 device provides a mechanism for interrupting the system when power changes have been made to the PC Card socket interfaces. The interrupt mechanism is designed to fit into a system maintenance interrupt (SMI) scheme. SMI interrupts are generated by the PCI6x20 device, when enabled, after a write cycle to either the socket control register (CB offset 10h, see Section 6.5) of the CardBus register set, or the ExCA power control register (ExCA offset 02h/42h/802h, see Section 5.3) causes a power cycle change sequence to be sent on the power switch interface.

The SMI control is programmed through three bits in the system control register (PCI offset 80h, see Section 4.29). These bits are SMIRROUTE (bit 26), SMISTATUS (bit 25), and SMIENB (bit 24). Table 3–12 describes the SMI control bits function.

**Table 3–12. SMI Control**

| BIT NAME  | FUNCTION  |
|-----------|---|
| SMIRROUTE | This shared bit controls whether the SMI interrupts are sent as a CSC interrupt or as IRQ2.                         |
| SMISTAT   | This socket-dependent bit is set when an SMI interrupt is pending. This status flag is cleared by writing back a 1. |
| SMIENB    | When set, SMI interrupt generation is enabled. This bit is shared by functions 0 and 1.                             |

If CSC SMI interrupts are selected, then the SMI interrupt is sent as the CSC on a per-socket basis. The CSC interrupt can be either level or edge mode, depending upon the CSCMODE bit in the ExCA global control register (ExCA offset 1Eh/5Eh/81Eh, see Section 5.20).

If IRQ2 is selected by SMIRROUTE, then the IRQSER signaling protocol supports SMI signaling in the IRQ2 IRQ/Data slot. In a parallel ISA IRQ system, the support for an active low IRQ2 is provided only if IRQ2 is routed to either MFUNC3 or MFUNC6 through the multifunction routing status register (PCI offset 8Ch, see Section 4.36).

## 3.9 Power Management Overview

In addition to the low-power CMOS technology process used for the PCI6x20 device, various features are designed into the device to allow implementation of popular power-saving techniques. These features and techniques are as follows:

- Clock run protocol
- Cardbus PC Card power management
- 16-bit PC Card power management
- Suspend mode
- Ring indicate

- PCI power management
- Cardbus bridge power management
- ACPI support

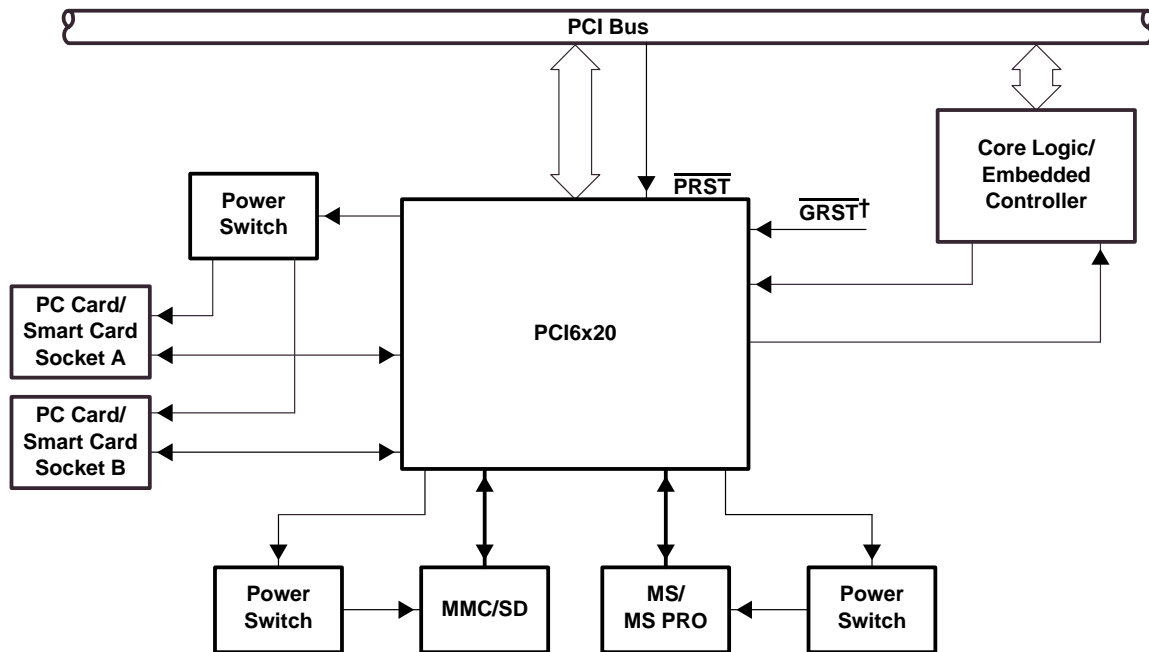

† The system connection to  $\overline{\text{GRST}}$  is implementation-specific.  $\overline{\text{GRST}}$  must be asserted on initial power up of the PCI6x20 device.  $\overline{\text{PRST}}$  must be asserted for subsequent warm resets.

Figure 3–12. System Diagram Implementing CardBus Device Class Power Management

### 3.9.1 Integrated Low-Dropout Voltage Regulator (LDO-VR)

The PCI6x20 device requires 1.8-V core voltage. The core power can be supplied by the PCI6x20 device itself using the internal LDO-VR. The core power can alternatively be supplied by an external power supply through the VR\_PORT terminal. Table 3–13 lists the requirements for both the internal core power supply and the external core power supply.

Table 3–13. Requirements for Internal/External 1.8-V Core Power Supply

| SUPPLY   | V <sub>CC</sub> | $\overline{\text{VR\_EN}}$ | VR_PORT      | NOTE  |
|----------|-----------------|----------------------------|--------------|---|
| Internal | 3.3 V           | GND                        | 1.8-V output | Internal 1.8-V LDO-VR is enabled. A 1.0- $\mu\text{F}$ bypass capacitor is required on the VR_PORT terminal for decoupling. This output is not for external use.                      |
| External | 3.3 V           | V <sub>CC</sub>            | 1.8-V input  | Internal 1.8-V LDO-VR is disabled. An external 1.8-V power supply, of minimum 50-mA capacity, is required. A 0.1- $\mu\text{F}$ bypass capacitor on the VR_PORT terminal is required. |

### 3.9.2 CardBus (Functions 0 and 1) Clock Run Protocol

The PCI  $\overline{\text{CLKRUN}}$  feature is the primary method of power management on the PCI interface of the PCI6x20 device.  $\overline{\text{CLKRUN}}$  signaling is provided through the MFUNC6 terminal. Since some chip sets do not implement  $\overline{\text{CLKRUN}}$ , this is not always available to the system designer, and alternate power-saving features are provided. For details on the  $\overline{\text{CLKRUN}}$  protocol see the *PCI Mobile Design Guide*.

The PCI6x20 device does not permit the central resource to stop the PCI clock under any of the following conditions:

- Bit 1 (KEEPCLK) in the system control register (PCI offset 80h, see Section 4.29) is set.
- The 16-bit PC Card resource manager is busy.
- The PCI6x20 CardBus master state machine is busy. A cycle may be in progress on CardBus.

- The PCI6x20 master is busy. There may be posted data from CardBus to PCI in the PCI6x20 device.
- Interrupts are pending.
- The CardBus CCLK for the socket has not been stopped by the PCI6x20  $\overline{\text{CCLKRUN}}$  manager.

The PCI6x20 device restarts the PCI clock using the  $\overline{\text{CLKRUN}}$  protocol under any of the following conditions:

- A 16-bit PC Card  $\overline{\text{IREQ}}$  or a CardBus  $\overline{\text{CINT}}$  has been asserted by either card.
- A CardBus CBWAKE (CSTSCHG) or 16-bit PC Card  $\overline{\text{STSCHG/RI}}$  event occurs in the socket.
- A CardBus attempts to start the CCLK using  $\overline{\text{CCLKRUN}}$ .
- A CardBus card arbitrates for the CardBus bus using  $\overline{\text{CREQ}}$ .
- Bit 1 (KEEPCLK) in the system control register (PCI offset 80h, see Section 4.29) is set.
- Data is in any of the FIFOs (receive or transmit).
- The master state machine is busy.
- There are pending interrupts.

### 3.9.3 CardBus PC Card Power Management

The PCI6x20 device implements its own card power-management engine that can turn off the CCLK to a socket when there is no activity to the CardBus PC Card. The PCI clock-run protocol is followed on the CardBus  $\overline{\text{CCLKRUN}}$  interface to control this clock management.

### 3.9.4 16-Bit PC Card Power Management

The COE bit (bit 7) of the ExCA power control register (ExCA offset 02h/42h/802h, see Section 5.3) and PWRDWN bit (bit 0) of the ExCA global control register (ExCA offset 1Eh/5Eh/81Eh, see Section 5.20) are provided for 16-bit PC Card power management. The COE bit places the card interface in a high-impedance state to save power. The power savings when using this feature are minimal. The COE bit resets the PC Card when used, and the PWRDWN bit does not. Furthermore, the PWRDWN bit is an automatic COE, that is, the PWRDWN performs the COE function when there is no card activity.

**NOTE:** The 16-bit PC Card must implement the proper pullup resistors for the COE and PWRDWN modes.

### 3.9.5 Suspend Mode

The  $\overline{\text{SUSPEND}}$  signal, provided for backward compatibility, gates the  $\overline{\text{PRST}}$  (PCI reset) signal and the  $\overline{\text{GRST}}$  (global reset) signal from the PCI6x20 device. Besides gating  $\overline{\text{PRST}}$  and  $\overline{\text{GRST}}$ ,  $\overline{\text{SUSPEND}}$  also gates PCLK inside the PCI6x20 device in order to minimize power consumption.

It should also be noted that asynchronous signals, such as card status change interrupts and  $\overline{\text{RI\_OUT}}$ , can be passed to the host system without a PCI clock. However, if card status change interrupts are routed over the serial interrupt stream, then the PCI clock must be restarted in order to pass the interrupt, because neither the internal oscillator nor an external clock is routed to the serial-interrupt state machine. Figure 3–13 is a signal diagram of the suspend function.

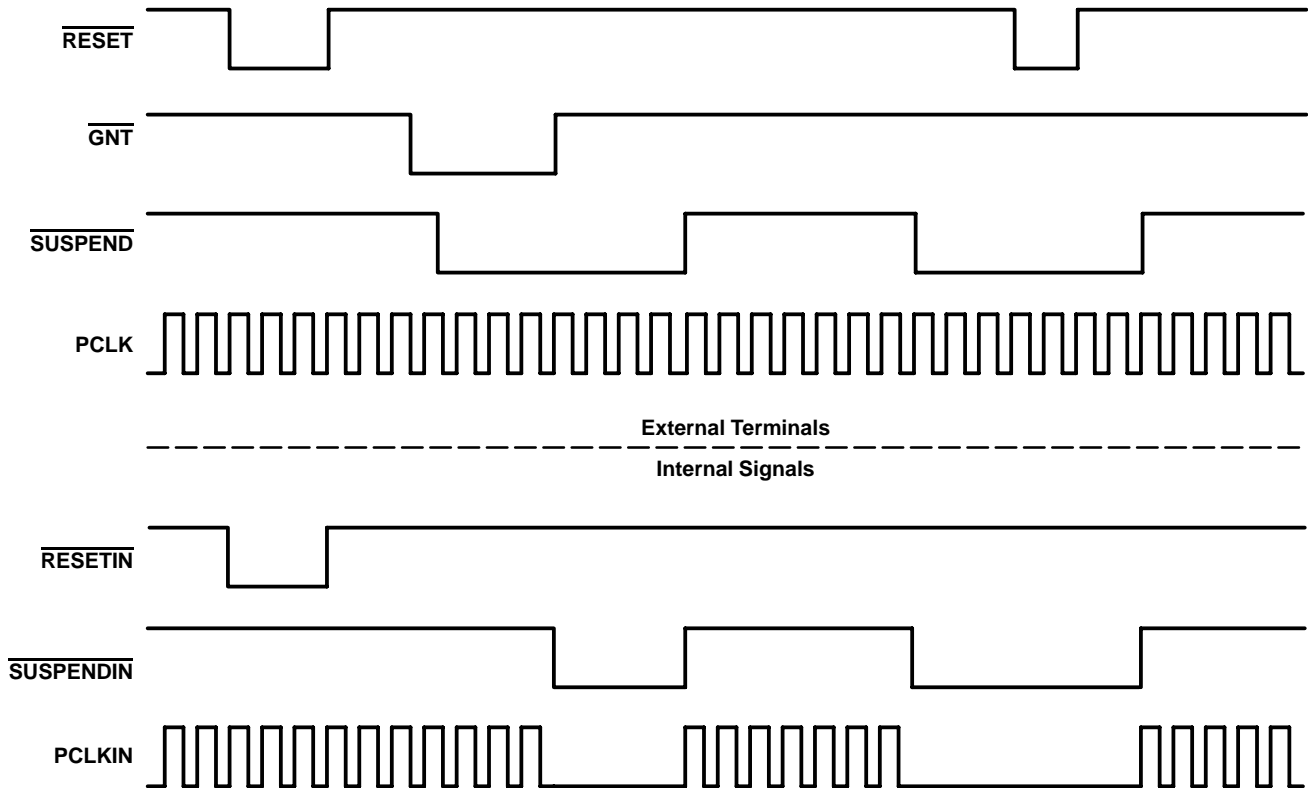

Figure 3–13. Signal Diagram of Suspend Function

### 3.9.6 Requirements for Suspend Mode

The suspend mode prevents the clearing of all register contents on the assertion of reset ( $\overline{\text{PRST}}$  or  $\overline{\text{GRST}}$ ) which would require the reconfiguration of the PCI6x20 device by software. Asserting the  $\overline{\text{SUSPEND}}$  signal places the PCI outputs of the controller in a high-impedance state and gates the PCLK signal internally to the controller unless a PCI transaction is currently in process ( $\overline{\text{GNT}}$  is asserted). It is important that the PCI bus not be parked on the PCI6x20 device when  $\overline{\text{SUSPEND}}$  is asserted, because the outputs are in a high-impedance state.

The GPIOs, MFUNC signals, and  $\overline{\text{RI\_OUT}}$  signal are all active during  $\overline{\text{SUSPEND}}$ , unless they are disabled in the appropriate PCI6x20 registers.

### 3.9.7 Ring Indicate

The  $\overline{\text{RI\_OUT}}$  output is an important feature in power management, allowing a system to go into a suspended mode and wake-up on modem rings and other card events. TI-designed flexibility permits this signal to fit wide platform requirements.  $\overline{\text{RI\_OUT}}$  on the PCI6x20 device can be asserted under any of the following conditions:

- A 16-bit PC Card modem in a powered socket asserts  $\overline{\text{RI}}$  to indicate to the system the presence of an incoming call.
- A powered down CardBus card asserts CSTSCHG (CBWAKE) requesting system and interface wake-up.
- A powered CardBus card asserts CSTSCHG from the insertion/removal of cards or change in battery voltage levels.

Figure 3–14 shows various enable bits for the PCI6x20  $\overline{\text{RI\_OUT}}$  function; however, it does not show the masking of CSC events. See Table 3–9 for a detailed description of CSC interrupt masks and flags.

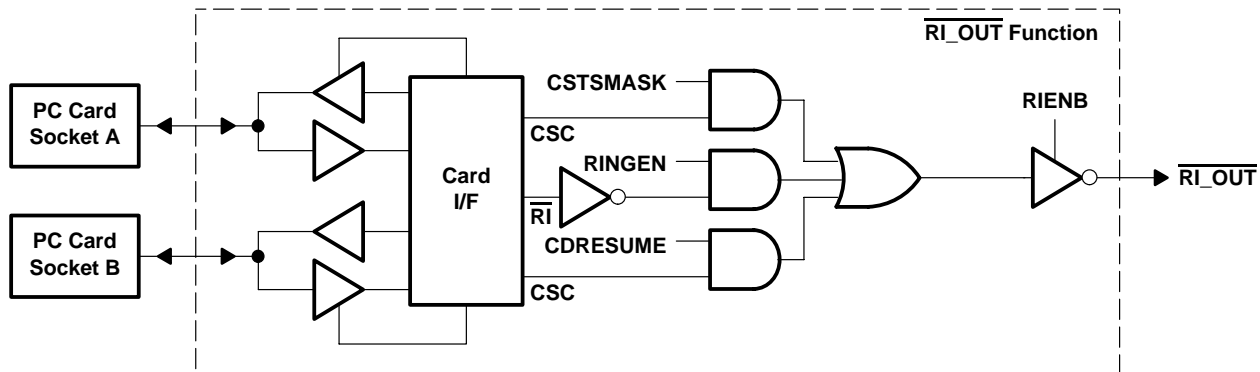

**Figure 3–14.  $\overline{RI\_OUT}$  Functional Diagram**

$\overline{RI}$  from the 16-bit PC Card interface is masked by bit 7 (RINGEN) in the ExCA interrupt and general control register (ExCA offset 03h/43h/803h, see Section 5.4). This is programmed on a per-socket basis and is only applicable when a 16-bit card is powered in the socket.

The CBWAKE signaling to  $\overline{RI\_OUT}$  is enabled through the same mask as the CSC event for CSTSCHG. The mask bit (bit 0, CSTSMASK) is programmed through the socket mask register (CB offset 04h, see Section 6.2) in the CardBus socket registers.

$\overline{RI\_OUT}$  can be routed through any of three different pins,  $\overline{RI\_OUT/PME}$ , MFUNC2, or MFUNC4. The  $\overline{RI\_OUT}$  function is enabled by setting bit 7 (RIENB) in the card control register (PCI offset 91h, see Section 4.38). The  $\overline{PME}$  function is enabled by setting bit 8 (PME\_ENABLE) in the power-management control/status register (PCI offset A4h, see Section 4.44). When bit 0 (RIMUX) in the system control register (PCI offset 80h, see Section 4.29) is set to 0, both the  $\overline{RI\_OUT}$  function and the  $\overline{PME}$  function are routed to the  $\overline{RI\_OUT/PME}$  terminal. If both functions are enabled and RIMUX is set to 0, then the  $\overline{RI\_OUT/PME}$  terminal becomes  $\overline{RI\_OUT}$  only and  $\overline{PME}$  assertions are never seen. Therefore, in a system using both the  $\overline{RI\_OUT}$  function and the  $\overline{PME}$  function, RIMUX must be set to 1 and  $\overline{RI\_OUT}$  must be routed to either MFUNC2 or MFUNC4.

### 3.9.8 PCI Power Management

#### 3.9.8.1 CardBus Power Management (Functions 0 and 1)

The *PCI Bus Power Management Interface Specification for PCI to CardBus Bridges* establishes the infrastructure required to let the operating system control the power of PCI functions. This is done by defining a standard PCI interface and operations to manage the power of PCI functions on the bus. The PCI bus and the PCI functions can be assigned one of seven power-management states, resulting in varying levels of power savings.

The seven power-management states of PCI functions are:

- D0-uninitialized – Before device configuration, device not fully functional
- D0-active – Fully functional state
- D1 – Low-power state
- D2 – Low-power state
- D3<sub>hot</sub> – Low-power state. Transition state before D3<sub>cold</sub>
- D3<sub>cold</sub> –  $\overline{PME}$  signal-generation capable. Main power is removed and VAUX is available.
- D3<sub>off</sub> – No power and completely nonfunctional

NOTE 1: In the D0-uninitialized state, the PCI6x20 device does not generate  $\overline{PME}$  and/or interrupts. When bits 0 (IO\_EN) and 1 (MEM\_EN) of the command register (PCI offset 04h, see Section 4.4) are both set, the PCI6x20 device switches the state to D0-active. Transition from D3<sub>cold</sub> to the D0-uninitialized state happens at the deassertion of PRST. The assertion of GRST forces the controller to the D0-uninitialized state immediately.

NOTE 2: The PWR\_STATE bits (bits 1–0) of the power-management control/status register (PCI offset A4h, see Section 4.44) only code for four power states, D0, D1, D2, and D3<sub>hot</sub>. The differences between the three D3 states is invisible to the software because the controller is not accessible in the D3<sub>cold</sub> or D3<sub>off</sub> state.

Similarly, bus power states of the PCI bus are B0–B3. The bus power states B0–B3 are derived from the device power state of the originating bridge device.

For the operating system (OS) to manage the device power states on the PCI bus, the PCI function must support four power-management operations. These operations are:

- Capabilities reporting
- Power status reporting
- Setting the power state
- System wake-up

The OS identifies the capabilities of the PCI function by traversing the new capabilities list. The presence of capabilities in addition to the standard PCI capabilities is indicated by a 1 in bit 4 (CAPLIST) of the status register (PCI offset 06h, see Section 4.5).

The capabilities pointer provides access to the first item in the linked list of capabilities. For the PCI6x20 device, a CardBus bridge with PCI configuration space header type 2, the capabilities pointer is mapped to an offset of 14h. The first byte of each capability register block is required to be a unique ID of that capability. PCI power management has been assigned an ID of 01h. The next byte is a pointer to the next pointer item in the list of capabilities. If there are no more items in the list, then the next item pointer must be set to 0. The registers following the next item pointer are specific to the capability of the function. The PCI power-management capability implements the register block outlined in Table 3–14.

**Table 3–14. Power-Management Registers**

| REGISTER NAME                 |  |                                       | OFFSET |
|-------------------------------|--|---------------------------------------|--------|
| Power-management capabilities |  | Next item pointer                     | A0h    |
| Data                          | Power-management control/status register bridge support extensions | Power-management control/status (CSR) | A4h    |

The power-management capabilities register (PCI offset A2h, see Section 4.43) provides information on the capabilities of the function related to power management. The power-management control/status register (PCI offset A4h, see Section 4.44) enables control of power-management states and enables/monitors power-management events. The data register is an optional register that can provide dynamic data.

For more information on PCI power management, see the *PCI Bus Power Management Interface Specification for PCI to CardBus Bridges*.

### 3.9.8.2 Flash Media (Function 3) Power Management

The *PCI Bus Power Management Interface Specification* is applicable for the flash media dedicated sockets. This function supports the D0 and D3 power states.

**Table 3–15. Function 3 Power-Management Registers**

| REGISTER NAME                 |  |                                       | OFFSET |
|-------------------------------|--|---------------------------------------|--------|
| Power-management capabilities |  | Next item pointer                     | 44h    |
| Data                          | Power-management control/status register bridge support extensions | Power-management control/status (CSR) | 48h    |

### 3.9.9 CardBus Bridge Power Management

The *PCI Bus Power Management Interface Specification for PCI to CardBus Bridges* was approved by PCMCIA in December of 1997. This specification follows the device and bus state definitions provided in the *PCI Bus Power Management Interface Specification* published by the PCI Special Interest Group (SIG). The main issue addressed in the *PCI Bus Power Management Interface Specification for PCI to CardBus Bridges* is wake-up from D3<sub>hot</sub> or D3<sub>cold</sub> without losing wake-up context (also called  $\overline{\text{PME}}$  context).

The specific issues addressed by the *PCI Bus Power Management Interface Specification for PCI to CardBus Bridges* for D3 wake-up are as follows:

- Preservation of device context. The specification states that a reset must occur during the transition from D3 to D0. Some method to preserve wake-up context must be implemented so that the reset does not clear the  $\overline{\text{PME}}$  context registers.
- Power source in D3<sub>cold</sub> if wake-up support is required from this state.

The Texas Instruments PCI6x20 device addresses these D3 wake-up issues in the following manner:

- Two resets are provided to handle preservation of  $\overline{\text{PME}}$  context bits:
  - Global reset ( $\overline{\text{GRST}}$ ) is used only on the initial boot up of the system after power up. It places the PCI6x20 device in its default state and requires BIOS to configure the device before becoming fully functional.
  - PCI reset ( $\overline{\text{PRST}}$ ) has dual functionality based on whether  $\overline{\text{PME}}$  is enabled or not. If  $\overline{\text{PME}}$  is enabled, then  $\overline{\text{PME}}$  context is preserved. If  $\overline{\text{PME}}$  is not enabled, then  $\overline{\text{PRST}}$  acts the same as a normal PCI reset. Please see the master list of  $\overline{\text{PME}}$  context bits in Section 3.9.11.
- Power source in D3<sub>cold</sub> if wake-up support is required from this state. Since  $V_{\text{CC}}$  is removed in D3<sub>cold</sub>, an auxiliary power source must be supplied to the PCI6x20  $V_{\text{CC}}$  terminals. Consult the *PCI14xx Implementation Guide for D3 Wake-Up* or the *PCI Power Management Interface Specification for PCI to CardBus Bridges* for further information.

### 3.9.10 ACPI Support

The *Advanced Configuration and Power Interface (ACPI) Specification* provides a mechanism that allows unique pieces of hardware to be described to the ACPI driver. The PCI6x20 device offers a generic interface that is compliant with ACPI design rules.

Two doublewords of general-purpose ACPI programming bits reside in PCI6x20 PCI configuration space at offset 88h. The programming model is broken into status and control functions. In compliance with ACPI, the top level event status and enable bits reside in the general-purpose event status register (PCI offset 88h, see Section 4.32) and general-purpose event enable register (PCI offset 89h, see Section 4.33). The status and enable bits are implemented as defined by ACPI and illustrated in Figure 3–15.

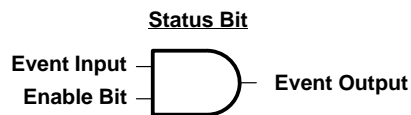

**Figure 3–15. Block Diagram of a Status/Enable Cell**

The status and enable bits generate an event that allows the ACPI driver to call a control method associated with the pending status bit. The control method can then control the hardware by manipulating the hardware control bits or by investigating child status bits and calling their respective control methods. A hierarchical implementation would be somewhat limiting, however, as upstream devices would have to remain in some level of power state to report events.

For more information of ACPI, see the *Advanced Configuration and Power Interface (ACPI) Specification*.

### 3.9.11 Master List of $\overline{\text{PME}}$ Context Bits and Global Reset-Only Bits

$\overline{\text{PME}}$  context bit means that the bit is cleared only by the assertion of  $\overline{\text{GRST}}$  when the  $\overline{\text{PME}}$  enable bit, bit 8 of the power management control/status register (PCI offset A4h, see Section 4.44) is set. If  $\overline{\text{PME}}$  is not enabled, then these bits are cleared when either  $\overline{\text{PRST}}$  or  $\overline{\text{GRST}}$  is asserted.

The  $\overline{\text{PME}}$  context bits (functions 0 and 1) are:

- Bridge control register (PCI offset 3Eh, see Section 4.25): bit 6
- System control register (PCI offset 80h, see Section 4.29): bits 10–8
- Power management control/status register (PCI offset A4h, see Section 4.44): bit 15
- ExCA power control register (ExCA 802h/842h, see Section 5.3): bits 7, 5 (82365SL mode only), 4, 3, 1, 0
- ExCA interrupt and general control (ExCA 803h/843h, see Section 5.4): bits 6, 5
- ExCA card status-change register (ExCA 804h/844h, see Section 5.5): bits 3–0
- ExCA card status-change interrupt configuration register (ExCA 805h/845h, see Section 5.6): bits 3–0
- ExCA card detect and general control register (ExCA 816h/856h, see Section 5.19): bits 7–6
- Socket event register (CardBus offset 00h, see Section 6.1): bits 3–0
- Socket mask register (CardBus offset 04h, see Section 6.2): bits 3–0
- Socket present state register (CardBus offset 08h, see Section 6.3): bits 13–7, 5–1
- Socket control register (CardBus offset 10h, see Section 6.5): bits 6–4, 2–0

Global reset-only bits, as the name implies, are cleared only by  $\overline{\text{GRST}}$ . These bits are never cleared by  $\overline{\text{PRST}}$ , regardless of the setting of the  $\overline{\text{PME}}$  enable bit. The  $\overline{\text{GRST}}$  signal is gated only by the  $\overline{\text{SUSPEND}}$  signal. This means that assertion of  $\overline{\text{SUSPEND}}$  blocks the  $\overline{\text{GRST}}$  signal internally, thus preserving all register contents. Figure 3–12 is a diagram showing the application of  $\overline{\text{GRST}}$  and  $\overline{\text{PRST}}$ .

The global reset-only bits (functions 0 and 1) are:

- Status register (PCI offset 06h, see Section 4.5): bits 15–11, 8
- Secondary status register (PCI offset 16h, see Section 4.14): bits 15–11, 8
- Subsystem vendor ID register (PCI offset 40h, see Section 4.26): bits 15–0
- Subsystem ID register (PCI offset 42h, see Section 4.27): bits 15–0
- PC Card 16-bit I/F legacy-mode base-address register (PCI offset 44h, see Section 4.28): bits 31–0
- System control register (PCI offset 80h, see Section 4.29): bits 31–24, 22–13, 11, 6–0
- MC\_CD debounce register (PCI offset 84h, see Section 4.30): bits 7–0
- General control register (PCI offset 86h, see Section 4.31): bits 13–10, 7, 5–3, 1, 0
- General-purpose event status register (PCI offset 88h, see Section 4.32): bits 7, 6, 4–0
- General-purpose event enable register (PCI offset 89h, see Section 4.33): bits 7, 6, 4–0
- General-purpose output register (PCI offset 8Bh, see Section 4.35): bits 4–0
- Multifunction routing register (PCI offset 8Ch, see Section 4.36): bits 31–0
- Retry status register (PCI offset 90h, see Section 4.37): bits 7–5, 3, 1
- Card control register (PCI offset 91h, see Section 4.38): bits 7, 2–0
- Device control register (PCI offset 92h, see Section 4.39): bits 7–5, 3–0
- Diagnostic register (PCI offset 93h, see Section 4.40): bits 7–0
- Power management capabilities register (PCI offset A2h, see Section 4.43): bit 15
- Power management CSR register (PCI offset A4h, see Section 4.44): bits 15, 8
- Serial bus data register (PCI offset B0h, see Section 4.47): bits 7–0
- Serial bus index register (PCI offset B1h, see Section 4.48): bits 7–0
- Serial bus slave address register (PCI offset B2h, see Section 4.49): bits 7–0
- Serial bus control/status register (PCI offset B3h, see Section 4.50): bits 7, 3–0
- ExCA identification and revision register (ExCA 800h/840h, see Section 5.1): bits 7–0
- ExCA global control register (ExCA 81Eh/85Eh, see Section 5.20): bits 2–0
- CardBus socket power management register (CardBus 20h, see Section 6.6): bits 25, 24

The global reset-only (function 3) register bits:

- Subsystem vendor ID register (PCI offset 2Ch, see Section 7.9): bits 15–0
- Subsystem ID register (PCI offset 2Eh, see Section 7.10): bits 15–0
- Power management control and status register (PCI offset 48h, see Section 7.18): bits 15, 8, 1, 0
- General control register (PCI offset 4Ch, see Section 7.21): bits 6–4, 2–0
- Diagnostic register (PCI offset 54h, see Section 7.23): bits 31–0



## 4 PC Card Controller Programming Model

This chapter describes the PCI6x20 PCI configuration registers that make up the 256-byte PCI configuration header for each PCI6x20 function. There are some bits which affect both CardBus functions, but which, in order to work properly, must be accessed only through function 0. These are called global bits. Registers containing one or more global bits are denoted by § in Table 4–2.

Any bit followed by a † is not cleared by the assertion of  $\overline{PRST}$  (see *CardBus Bridge Power Management*, Section 3.9.9, for more details) if PME is enabled (PCI offset A4h, bit 8). In this case, these bits are cleared only by  $\overline{GRST}$ . If PME is not enabled, then these bits are cleared by  $\overline{GRST}$  or  $\overline{PRST}$ . These bits are sometimes referred to as PME context bits and are implemented to allow PME context to be preserved during the transition from D3<sub>hot</sub> or D3<sub>cold</sub> to D0.

If a bit is followed by a ‡, then this bit is cleared only by  $\overline{GRST}$  in all cases (not conditional on  $\overline{PME}$  being enabled). These bits are intended to maintain device context such as interrupt routing and MFUNC programming during warm resets.

A bit description table, typically included when the register contains bits of more than one type or purpose, indicates bit field names, a detailed field description, and field access tags which appear in the *type* column. Table 4–1 describes the field access tags.

**Table 4–1. Bit Field Access Tag Descriptions**

| ACCESS TAG | NAME   | MEANING   |
|------------|--------|---|
| R          | Read   | Field can be read by software.                                    |
| W          | Write  | Field can be written by software to any value.                    |
| S          | Set    | Field can be set by a write of 1. Writes of 0 have no effect.     |
| C          | Clear  | Field can be cleared by a write of 1. Writes of 0 have no effect. |
| U          | Update | Field can be autonomously updated by the PCI6x20 device.          |

### 4.1 PCI Configuration Register Map (Functions 0 and 1)

The PCI6x20 is a multifunction PCI device, and the PC Card controller is integrated as PCI functions 0 and 1. The configuration header, compliant with the *PCI Local Bus Specification* as a CardBus bridge header, is *PC99/PC2001* compliant as well. Table 4–2 illustrates the PCI configuration register map, which includes both the predefined portion of the configuration space and the user-definable registers.

**Table 4–2. Functions 0 and 1 PCI Configuration Register Map**

| REGISTER NAME                                       |                        |                    |                    | OFFSET |
|---|------------------------|--------------------|--------------------|--------|
| Device ID   |                        | Vendor ID          |                    | 00h    |
| Status ‡  |                        | Command            |                    | 04h    |
| Class code  |                        |                    | Revision ID        | 08h    |
| BIST  | Header type            | Latency timer      | Cache line size    | 0Ch    |
| CardBus socket registers/ExCA base address register |                        |                    |                    | 10h    |
| Secondary status ‡                                  |                        | Reserved           | Capability pointer | 14h    |
| CardBus latency timer                               | Subordinate bus number | CardBus bus number | PCI bus number     | 18h    |
| CardBus memory base register 0                      |                        |                    |                    | 1Ch    |
| CardBus memory limit register 0                     |                        |                    |                    | 20h    |
| CardBus memory base register 1                      |                        |                    |                    | 24h    |
| CardBus memory limit register 1                     |                        |                    |                    | 28h    |

‡ One or more bits in this register are cleared only by the assertion of  $\overline{GRST}$ .

**Table 4–2. Functions 0 and 1 PCI Configuration Register Map (Continued)**

| REGISTER NAME                                 |   |                                    |                                | OFFSET  |
|---|---|------------------------------------|--------------------------------|---------|
| CardBus I/O base register 0                   |   |                                    |                                | 2Ch     |
| CardBus I/O limit register 0                  |   |                                    |                                | 30h     |
| CardBus I/O base register 1                   |   |                                    |                                | 34h     |
| CardBus I/O limit register 1                  |   |                                    |                                | 38h     |
| Bridge control †                              |   | Interrupt pin                      | Interrupt line                 | 3Ch     |
| Subsystem ID ‡                                |   | Subsystem vendor ID ‡              |                                | 40h     |
| PC Card 16-bit I/F legacy-mode base-address ‡ |   |                                    |                                | 44h     |
| Reserved                                      |   |                                    |                                | 48h–7Ch |
| System control †‡§                            |   |                                    |                                | 80h     |
| General control ‡§                            |   | Reserved                           | MC_CD debounce ‡               | 84h     |
| General-purpose output ‡                      | General-purpose input                                     | General-purpose event enable ‡     | General-purpose event status ‡ | 88h     |
| Multifunction routing status ‡                |   |                                    |                                | 8Ch     |
| Diagnostic ‡§                                 | Device control ‡§   | Card control ‡§                    | Retry status ‡§                | 90h     |
| Reserved                                      |   |                                    |                                | 94h–9Ch |
| Power management capabilities ‡               |   | Next item pointer                  | Capability ID                  | A0h     |
| Power management data (Reserved)              | Power management control/status bridge support extensions | Power management control/status †‡ |                                | A4h     |
| Reserved                                      |   |                                    |                                | A8h–ACh |
| Serial bus control/status ‡                   | Serial bus slave address ‡                                | Serial bus index ‡                 | Serial bus data ‡              | B0h     |
| Reserved                                      |   |                                    |                                | B4h–FCh |

† One or more bits in this register are PME context bits and can be cleared only by the assertion of  $\overline{GRST}$  when  $\overline{PME}$  is enabled. If  $\overline{PME}$  is not enabled, then this bit is cleared by the assertion of  $\overline{PRST}$  or  $\overline{GRST}$ .

‡ One or more bits in this register are cleared only by the assertion of  $\overline{GRST}$ .

§ One or more bits in this register are global in nature and must be accessed only through function 0.

## 4.2 Vendor ID Register

The vendor ID register contains a value allocated by the PCI SIG that identifies the manufacturer of the PCI device. The vendor ID assigned to Texas Instruments is 104Ch.

| Bit     | 15        | 14 | 13 | 12 | 11 | 10 | 9 | 8 | 7 | 6 | 5 | 4 | 3 | 2 | 1 | 0 |
|---------|-----------|----|----|----|----|----|---|---|---|---|---|---|---|---|---|---|
| Name    | Vendor ID |    |    |    |    |    |   |   |   |   |   |   |   |   |   |   |
| Type    | R         | R  | R  | R  | R  | R  | R | R | R | R | R | R | R | R | R | R |
| Default | 0         | 0  | 0  | 1  | 0  | 0  | 0 | 0 | 0 | 1 | 0 | 0 | 1 | 1 | 0 | 0 |

Register: **Vendor ID**  
 Offset: 00h (Functions 0, 1)  
 Type: Read-only  
 Default: 104Ch

### 4.3 Device ID Register Functions 0 and 1

This read-only register contains the device ID assigned by TI to the PCI6x20 CardBus controller functions (PCI functions 0 and 1). When Smart Card is enabled (PCI6620), the device ID is AC8Dh. When Smart Card is disabled (PCI6420), the device ID is AC8Eh.

| Bit            | 15                           | 14 | 13 | 12 | 11 | 10 | 9 | 8 | 7 | 6 | 5 | 4 | 3 | 2 | 1 | 0 |
|----------------|------------------------------|----|----|----|----|----|---|---|---|---|---|---|---|---|---|---|
| <b>Name</b>    | Device ID—Smart Card enabled |    |    |    |    |    |   |   |   |   |   |   |   |   |   |   |
| <b>Type</b>    | R                            | R  | R  | R  | R  | R  | R | R | R | R | R | R | R | R | R | R |
| <b>Default</b> | 1                            | 0  | 1  | 0  | 1  | 1  | 0 | 0 | 1 | 0 | 0 | 0 | 1 | 1 | 0 | 1 |

Register: **Device ID (PCI6620)**  
 Offset: 02h (Functions 0 and 1)  
 Type: Read-only  
 Default: AC8Dh

| Bit            | 15                            | 14 | 13 | 12 | 11 | 10 | 9 | 8 | 7 | 6 | 5 | 4 | 3 | 2 | 1 | 0 |
|----------------|-------------------------------|----|----|----|----|----|---|---|---|---|---|---|---|---|---|---|
| <b>Name</b>    | Device ID—Smart Card disabled |    |    |    |    |    |   |   |   |   |   |   |   |   |   |   |
| <b>Type</b>    | R                             | R  | R  | R  | R  | R  | R | R | R | R | R | R | R | R | R | R |
| <b>Default</b> | 1                             | 0  | 1  | 0  | 1  | 1  | 0 | 0 | 1 | 0 | 0 | 0 | 1 | 1 | 1 | 0 |

Register: **Device ID (PCI6420)**  
 Offset: 02h (Functions 0 and 1)  
 Type: Read-only  
 Default: AC8Eh

## 4.4 Command Register

The PCI command register provides control over the PCI6x20 interface to the PCI bus. All bit functions adhere to the definitions in the *PCI Local Bus Specification* (see Table 4–3). None of the bit functions in this register are shared among the PCI6x20 PCI functions. Three command registers exist in the PCI6x20 device, one for each function. Software manipulates the PCI6x20 functions as separate entities when enabling functionality through the command register. The SERR\_EN and PERR\_EN enable bits in this register are internally wired OR between the three functions, and these control bits appear to software to be separate for each function.

| Bit     | 15      | 14 | 13 | 12 | 11 | 10 | 9 | 8  | 7 | 6  | 5  | 4 | 3 | 2  | 1  | 0  |
|---------|---------|----|----|----|----|----|---|----|---|----|----|---|---|----|----|----|
| Name    | Command |    |    |    |    |    |   |    |   |    |    |   |   |    |    |    |
| Type    | R       | R  | R  | R  | R  | RW | R | RW | R | RW | RW | R | R | RW | RW | RW |
| Default | 0       | 0  | 0  | 0  | 0  | 0  | 0 | 0  | 0 | 0  | 0  | 0 | 0 | 0  | 0  | 0  |

Register: **Command**  
 Offset: 04h  
 Type: Read-only, Read/Write  
 Default: 0000h

**Table 4–3. Command Register Description**

| BIT   | SIGNAL      | TYPE | FUNCTION   |
|-------|-------------|------|--|
| 15–11 | RSVD        | R    | Reserved. Bits 15–11 return 0s when read.  |
| 10    | INT_DISABLE | RW   | INTx disable. When set to 1, this bit disables the function from asserting interrupts on the INTx signals.<br>0 = INTx assertion is enabled (default)<br>1 = INTx assertion is disabled  |
| 9     | FBB_EN      | R    | Fast back-to-back enable. The PCI6x20 device does not generate fast back-to-back transactions; therefore, this bit is read-only. This bit returns a 0 when read.   |
| 8     | SERR_EN     | RW   | System error (SERR) enable. This bit controls the enable for the SERR driver on the PCI interface. SERR can be asserted after detecting an address parity error on the PCI bus. Both this bit and bit 6 must be set for the PCI6x20 device to report address parity errors.<br>0 = Disables the SERR output driver (default)<br>1 = Enables the SERR output driver   |
| 7     | RSVD        | R    | Reserved. Bit 7 returns 0 when read.   |
| 6     | PERR_EN     | RW   | Parity error response enable. This bit controls the PCI6x20 response to parity errors through the PERR signal. Data parity errors are indicated by asserting PERR, while address parity errors are indicated by asserting SERR.<br>0 = PCI6x20 device ignores detected parity errors (default).<br>1 = PCI6x20 device responds to detected parity errors.            |
| 5     | VGA_EN      | RW   | VGA palette snoop. When set to 1, palette snooping is enabled (i.e., the PCI6x20 device does not respond to palette register writes and snoops the data). When the bit is 0, the PCI6x20 device treats all palette accesses like all other accesses.   |
| 4     | MWI_EN      | R    | Memory write-and-invalidate enable. This bit controls whether a PCI initiator device can generate memory write-and-invalidate commands. The PCI6x20 controller does not support memory write-and-invalidate commands, it uses memory write commands instead; therefore, this bit is hardwired to 0. This bit returns 0 when read. Writes to this bit have no effect. |
| 3     | SPECIAL     | R    | Special cycles. This bit controls whether or not a PCI device ignores PCI special cycles. The PCI6x20 device does not respond to special cycle operations; therefore, this bit is hardwired to 0. This bit returns 0 when read. Writes to this bit have no effect.   |
| 2     | MAST_EN     | RW   | Bus master control. This bit controls whether or not the PCI6x20 device can act as a PCI bus initiator (master). The PCI6x20 device can take control of the PCI bus only when this bit is set.<br>0 = Disables the PCI6x20 ability to generate PCI bus accesses (default)<br>1 = Enables the PCI6x20 ability to generate PCI bus accesses                            |

**Table 4–3. Command Register Description (continued)**

| BIT | SIGNAL | TYPE | FUNCTION  |
|-----|--------|------|---|
| 1   | MEM_EN | RW   | Memory space enable. This bit controls whether or not the PCI6x20 device can claim cycles in PCI memory space.<br>0 = Disables the PCI6x20 response to memory space accesses (default)<br>1 = Enables the PCI6x20 response to memory space accesses             |
| 0   | IO_EN  | RW   | I/O space control. This bit controls whether or not the PCI6x20 device can claim cycles in PCI I/O space.<br>0 = Disables the PCI6x20 device from responding to I/O space accesses (default)<br>1 = Enables the PCI6x20 device to respond to I/O space accesses |

## 4.5 Status Register

The status register provides device information to the host system. Bits in this register can be read normally. A bit in the status register is reset when a 1 is written to that bit location; a 0 written to a bit location has no effect. All bit functions adhere to the definitions in the *PCI Bus Specification*, as seen in the bit descriptions. PCI bus status is shown through each function. See Table 4–4 for a complete description of the register contents.

| Bit     | 15     | 14 | 13 | 12 | 11 | 10 | 9 | 8  | 7 | 6 | 5 | 4 | 3  | 2 | 1 | 0 |
|---------|--------|----|----|----|----|----|---|----|---|---|---|---|----|---|---|---|
| Name    | Status |    |    |    |    |    |   |    |   |   |   |   |    |   |   |   |
| Type    | RW     | RW | RW | RW | RW | R  | R | RW | R | R | R | R | RU | R | R | R |
| Default | 0      | 0  | 0  | 0  | 0  | 0  | 1 | 0  | 0 | 0 | 0 | 1 | 0  | 0 | 0 | 0 |

Register: **Status**  
 Offset: 06h (Functions 0, 1)  
 Type: Read-only, Read/Write  
 Default: 0210h

**Table 4–4. Status Register Description**

| BIT  | SIGNAL    | TYPE | FUNCTION   |
|------|-----------|------|--|
| 15 ‡ | PAR_ERR   | RW   | Detected parity error. This bit is set when a parity error is detected, either an address or data parity error. Write a 1 to clear this bit.   |
| 14 ‡ | SYS_ERR   | RW   | Signaled system error. This bit is set when <u>SERR</u> is enabled and the PCI6x20 device signaled a system error to the host. Write a 1 to clear this bit.  |
| 13 ‡ | MABORT    | RW   | Received master abort. This bit is set when a cycle initiated by the PCI6x20 device on the PCI bus has been terminated by a master abort. Write a 1 to clear this bit.   |
| 12 ‡ | TABT_REC  | RW   | Received target abort. This bit is set when a cycle initiated by the PCI6x20 device on the PCI bus was terminated by a target abort. Write a 1 to clear this bit.  |
| 11 ‡ | TABT_SIG  | RW   | Signaled target abort. This bit is set by the PCI6x20 device when it terminates a transaction on the PCI bus with a target abort. Write a 1 to clear this bit.   |
| 10–9 | PCI_SPEED | R    | DEVSEL timing. These bits encode the timing of <u>DEVSEL</u> and are hardwired to 01b indicating that the PCI6x20 device asserts this signal at a medium speed on nonconfiguration cycle accesses.   |
| 8 ‡  | DATAPAR   | RW   | Data parity error detected. Write a 1 to clear this bit.<br>0 = The conditions for setting this bit have not been met.<br>1 = A <u>data</u> parity error occurred and the following conditions were met:<br>a. <u>PERR</u> was asserted by any PCI device including the PCI6x20.<br>b. The PCI6x20 device was the bus master during the data parity error.<br>c. The parity error response bit is set in the command register. |
| 7    | FBB_CAP   | R    | Fast back-to-back capable. The PCI6x20 device cannot accept fast back-to-back transactions; thus, this bit is hardwired to 0.  |
| 6    | UDF       | R    | UDF supported. The PCI6x20 device does not support user-definable features; therefore, this bit is hardwired to 0.   |
| 5    | 66MHZ     | R    | 66-MHz capable. The PCI6x20 device operates at a maximum PCLK frequency of 33 MHz; therefore, this bit is hardwired to 0.  |

‡ One or more bits in this register are cleared only by the assertion of GRST.

**Table 4–4. Status Register Description (continued)**

| BIT | SIGNAL     | TYPE | FUNCTION   |
|-----|------------|------|--|
| 4   | CAPLIST    | R    | Capabilities list. This bit returns 1 when read. This bit indicates that capabilities in addition to standard PCI capabilities are implemented. The linked list of PCI power-management capabilities is implemented in this function.  |
| 3   | INT_STATUS | RU   | Interrupt status. This bit reflects the interrupt status of the function. Only when bit 10 (INT_DISABLE) in the command register (PCI offset 04h, see Section 4.4) is a 0 and this bit is a 1, will the function's INTx signal be asserted. Setting the INT_DISABLE bit to a 1 has no effect on the state of this bit. |
| 2–0 | RSVD       | R    | Reserved. These bits return 0s when read.  |

## 4.6 Revision ID Register

The revision ID register indicates the silicon revision of the PCI6x20 device.

| Bit     | 7           | 6 | 5 | 4 | 3 | 2 | 1 | 0 |
|---------|-------------|---|---|---|---|---|---|---|
| Name    | Revision ID |   |   |   |   |   |   |   |
| Type    | R           | R | R | R | R | R | R | R |
| Default | 0           | 0 | 0 | 0 | 0 | 0 | 0 | 0 |

Register: **Revision ID**  
 Offset: 08h (functions 0, 1)  
 Type: Read-only  
 Default: 00h

## 4.7 Class Code Register

The class code register recognizes PCI6x20 functions 0 and 1 as a bridge device (06h) and a CardBus bridge device (07h), with a 00h programming interface.

| Bit     | 23             | 22 | 21 | 20 | 19 | 18 | 17 | 16 | 15       | 14 | 13 | 12 | 11 | 10 | 9 | 8 | 7                     | 6 | 5 | 4 | 3 | 2 | 1 | 0 |   |
|---------|----------------|----|----|----|----|----|----|----|----------|----|----|----|----|----|---|---|-----------------------|---|---|---|---|---|---|---|---|
| Name    | PCI class code |    |    |    |    |    |    |    |          |    |    |    |    |    |   |   |                       |   |   |   |   |   |   |   |   |
|         | Base class     |    |    |    |    |    |    |    | Subclass |    |    |    |    |    |   |   | Programming interface |   |   |   |   |   |   |   |   |
| Type    | R              | R  | R  | R  | R  | R  | R  | R  | R        | R  | R  | R  | R  | R  | R | R | R                     | R | R | R | R | R | R | R | R |
| Default | 0              | 0  | 0  | 0  | 0  | 1  | 1  | 0  | 0        | 0  | 0  | 0  | 0  | 1  | 1 | 1 | 0                     | 0 | 0 | 0 | 0 | 0 | 0 | 0 |   |

Register: **PCI class code**  
 Offset: 09h (functions 0, 1)  
 Type: Read-only  
 Default: 06 0700h

## 4.8 Cache Line Size Register

The cache line size register is programmed by host software to indicate the system cache line size.

| Bit     | 7               | 6  | 5  | 4  | 3  | 2  | 1  | 0  |
|---------|-----------------|----|----|----|----|----|----|----|
| Name    | Cache line size |    |    |    |    |    |    |    |
| Type    | RW              | RW | RW | RW | RW | RW | RW | RW |
| Default | 0               | 0  | 0  | 0  | 0  | 0  | 0  | 0  |

Register: **Cache line size**  
 Offset: 0Ch (Functions 0, 1)  
 Type: Read/Write  
 Default: 00h

## 4.9 Latency Timer Register

The latency timer register specifies the latency timer for the PCI6x20 device, in units of PCI clock cycles. When the PCI6x20 device is a PCI bus initiator and asserts  $\overline{\text{FRAME}}$ , the latency timer begins counting from zero. If the latency timer expires before the PCI6x20 transaction has terminated, then the PCI6x20 device terminates the transaction when its  $\overline{\text{GNT}}$  is deasserted.

| Bit     | 7             | 6  | 5  | 4  | 3  | 2  | 1  | 0  |
|---------|---------------|----|----|----|----|----|----|----|
| Name    | Latency timer |    |    |    |    |    |    |    |
| Type    | RW            | RW | RW | RW | RW | RW | RW | RW |
| Default | 0             | 0  | 0  | 0  | 0  | 0  | 0  | 0  |

Register: **Latency timer**  
 Offset: 0Dh  
 Type: Read/Write  
 Default: 00h

## 4.10 Header Type Register

The header type register returns 82h when read, indicating that the PCI6x20 functions 0 and 1 configuration spaces adhere to the CardBus bridge PCI header. The CardBus bridge PCI header ranges from PCI registers 00h–7Fh, and 80h–FFh is user-definable extension registers.

| Bit     | 7           | 6 | 5 | 4 | 3 | 2 | 1 | 0 |
|---------|-------------|---|---|---|---|---|---|---|
| Name    | Header type |   |   |   |   |   |   |   |
| Type    | R           | R | R | R | R | R | R | R |
| Default | 1           | 0 | 0 | 0 | 0 | 0 | 1 | 0 |

Register: **Header type**  
 Offset: 0Eh (Functions 0, 1)  
 Type: Read-only  
 Default: 82h

## 4.11 BIST Register

Because the PCI6x20 device does not support a built-in self-test (BIST), this register returns the value of 00h when read.

| Bit     | 7    | 6 | 5 | 4 | 3 | 2 | 1 | 0 |
|---------|------|---|---|---|---|---|---|---|
| Name    | BIST |   |   |   |   |   |   |   |
| Type    | R    | R | R | R | R | R | R | R |
| Default | 0    | 0 | 0 | 0 | 0 | 0 | 0 | 0 |

Register: **BIST**  
 Offset: 0Fh (Functions 0, 1)  
 Type: Read-only  
 Default: 00h

## 4.12 CardBus Socket Registers/ExCA Base Address Register

This register is programmed with a base address referencing the CardBus socket registers and the memory-mapped ExCA register set. Bits 31–12 are read/write, and allow the base address to be located anywhere in the 32-bit PCI memory address space on a 4-Kbyte boundary. Bits 11–0 are read-only, returning 0s when read. When software writes all 1s to this register, the value read back is FFFF F000h, indicating that at least 4K bytes of memory address space are required. The CardBus registers start at offset 000h, and the memory-mapped ExCA registers begin at offset 800h. This register is not shared by functions 0 and 1, so the system maps each socket control register separately.

| Bit            | 31   | 30 | 29 | 28 | 27 | 26 | 25 | 24 | 23 | 22 | 21 | 20 | 19 | 18 | 17 | 16 |
|----------------|--|----|----|----|----|----|----|----|----|----|----|----|----|----|----|----|
| <b>Name</b>    | CardBus socket registers/ExCA base address |    |    |    |    |    |    |    |    |    |    |    |    |    |    |    |
| <b>Type</b>    | RW   | RW | RW | RW | RW | RW | RW | RW | RW | RW | RW | RW | RW | RW | RW | RW |
| <b>Default</b> | 0  | 0  | 0  | 0  | 0  | 0  | 0  | 0  | 0  | 0  | 0  | 0  | 0  | 0  | 0  | 0  |
| Bit            | 15   | 14 | 13 | 12 | 11 | 10 | 9  | 8  | 7  | 6  | 5  | 4  | 3  | 2  | 1  | 0  |
| <b>Name</b>    | CardBus socket registers/ExCA base address |    |    |    |    |    |    |    |    |    |    |    |    |    |    |    |
| <b>Type</b>    | RW   | RW | RW | RW | R  | R  | R  | R  | R  | R  | R  | R  | R  | R  | R  | R  |
| <b>Default</b> | 0  | 0  | 0  | 0  | 0  | 0  | 0  | 0  | 0  | 0  | 0  | 0  | 0  | 0  | 0  | 0  |

Register: **CardBus socket registers/ExCA base address**  
 Offset: 10h  
 Type: Read-only, Read/Write  
 Default: 0000 0000h

## 4.13 Capability Pointer Register

The capability pointer register provides a pointer into the PCI configuration header where the PCI power management register block resides. PCI header doublewords at A0h and A4h provide the power management (PM) registers. Each socket has its own capability pointer register. This register is read-only and returns A0h when read.

| Bit            | 7                  | 6 | 5 | 4 | 3 | 2 | 1 | 0 |
|----------------|--------------------|---|---|---|---|---|---|---|
| <b>Name</b>    | Capability pointer |   |   |   |   |   |   |   |
| <b>Type</b>    | R                  | R | R | R | R | R | R | R |
| <b>Default</b> | 1                  | 0 | 1 | 0 | 0 | 0 | 0 | 0 |

Register: **Capability pointer**  
 Offset: 14h  
 Type: Read-only  
 Default: A0h

## 4.14 Secondary Status Register

The secondary status register is compatible with the PCI-PCI bridge secondary status register. It indicates CardBus-related device information to the host system. This register is very similar to the PCI status register (PCI offset 06h, see Section 4.5), and status bits are cleared by a writing a 1. This register is not shared by the two socket functions, but is accessed on a per-socket basis. See Table 4–5 for a complete description of the register contents.

| Bit     | 15               | 14 | 13 | 12 | 11 | 10 | 9 | 8  | 7 | 6 | 5 | 4 | 3 | 2 | 1 | 0 |
|---------|------------------|----|----|----|----|----|---|----|---|---|---|---|---|---|---|---|
| Name    | Secondary status |    |    |    |    |    |   |    |   |   |   |   |   |   |   |   |
| Type    | RC               | RC | RC | RC | RC | R  | R | RC | R | R | R | R | R | R | R | R |
| Default | 0                | 0  | 0  | 0  | 0  | 0  | 1 | 0  | 0 | 0 | 0 | 0 | 0 | 0 | 0 | 0 |

Register: **Secondary status**  
 Offset: 16h  
 Type: Read-only, Read/Clear  
 Default: 0200h

**Table 4–5. Secondary Status Register Description**

| BIT  | SIGNAL    | TYPE | FUNCTION  |
|------|-----------|------|---|
| 15 ‡ | CBPARITY  | RC   | Detected parity error. This bit is set when a CardBus parity error is detected, either an address or data parity error. Write a 1 to clear this bit.  |
| 14 ‡ | CBSERR    | RC   | Signaled system error. This bit is set when $\overline{\text{CSERR}}$ is signaled by a CardBus card. The PCI6x20 device does not assert the $\overline{\text{CSERR}}$ signal. Write a 1 to clear this bit.  |
| 13 ‡ | CBMABORT  | RC   | Received master abort. This bit is set when a cycle initiated by the PCI6x20 device on the CardBus bus is terminated by a master abort. Write a 1 to clear this bit.  |
| 12 ‡ | REC_CBTA  | RC   | Received target abort. This bit is set when a cycle initiated by the PCI6x20 device on the CardBus bus is terminated by a target abort. Write a 1 to clear this bit.  |
| 11 ‡ | SIG_CBTA  | RC   | Signaled target abort. This bit is set by the PCI6x20 device when it terminates a transaction on the CardBus bus with a target abort. Write a 1 to clear this bit.  |
| 10–9 | CB_SPEED  | R    | CDEVSEL timing. These bits encode the timing of $\overline{\text{CDEVSEL}}$ and are hardwired to 01b indicating that the PCI6x20 device asserts this signal at a medium speed.  |
| 8 ‡  | CB_DPAR   | RC   | CardBus data parity error detected. Write a 1 to clear this bit.<br>0 = The conditions for setting this bit have not been met.<br>1 = A data parity error occurred and the following conditions were met:<br>a. $\overline{\text{CPERR}}$ was asserted on the CardBus interface.<br>b. The PCI6x20 device was the bus master during the data parity error.<br>c. The parity error response enable bit (bit 0) is set in the bridge control register (PCI offset 3Eh, see Section 4.25). |
| 7    | CBFBB_CAP | R    | Fast back-to-back capable. The PCI6x20 device cannot accept fast back-to-back transactions; therefore, this bit is hardwired to 0.  |
| 6    | CB_UDF    | R    | User-definable feature support. The PCI6x20 device does not support user-definable features; therefore, this bit is hardwired to 0.   |
| 5    | CB66MHZ   | R    | 66-MHz capable. The PCI6x20 CardBus interface operates at a maximum CCLK frequency of 33 MHz; therefore, this bit is hardwired to 0.  |
| 4–0  | RSVD      | R    | These bits return 0s when read.   |

‡ One or more bits in this register are cleared only by the assertion of  $\overline{\text{GRST}}$ .

## 4.15 PCI Bus Number Register

The PCI bus number register is programmed by the host system to indicate the bus number of the PCI bus to which the PCI6x20 device is connected. The PCI6x20 device uses this register in conjunction with the CardBus bus number and subordinate bus number registers to determine when to forward PCI configuration cycles to its secondary buses.

| Bit     | 7              | 6  | 5  | 4  | 3  | 2  | 1  | 0  |
|---------|----------------|----|----|----|----|----|----|----|
| Name    | PCI bus number |    |    |    |    |    |    |    |
| Type    | RW             | RW | RW | RW | RW | RW | RW | RW |
| Default | 0              | 0  | 0  | 0  | 0  | 0  | 0  | 0  |

Register: **PCI bus number**  
 Offset: 18h (Functions 0, 1)  
 Type: Read/Write  
 Default: 00h

## 4.16 CardBus Bus Number Register

The CardBus bus number register is programmed by the host system to indicate the bus number of the CardBus bus to which the PCI6x20 device is connected. The PCI6x20 device uses this register in conjunction with the PCI bus number and subordinate bus number registers to determine when to forward PCI configuration cycles to its secondary buses. This register is separate for each PCI6x20 controller function.

| Bit     | 7                  | 6  | 5  | 4  | 3  | 2  | 1  | 0  |
|---------|--------------------|----|----|----|----|----|----|----|
| Name    | CardBus bus number |    |    |    |    |    |    |    |
| Type    | RW                 | RW | RW | RW | RW | RW | RW | RW |
| Default | 0                  | 0  | 0  | 0  | 0  | 0  | 0  | 0  |

Register: **CardBus bus number**  
 Offset: 19h  
 Type: Read/Write  
 Default: 00h

## 4.17 Subordinate Bus Number Register

The subordinate bus number register is programmed by the host system to indicate the highest numbered bus below the CardBus bus. The PCI6x20 device uses this register in conjunction with the PCI bus number and CardBus bus number registers to determine when to forward PCI configuration cycles to its secondary buses. This register is separate for each CardBus controller function.

| Bit     | 7                      | 6  | 5  | 4  | 3  | 2  | 1  | 0  |
|---------|------------------------|----|----|----|----|----|----|----|
| Name    | Subordinate bus number |    |    |    |    |    |    |    |
| Type    | RW                     | RW | RW | RW | RW | RW | RW | RW |
| Default | 0                      | 0  | 0  | 0  | 0  | 0  | 0  | 0  |

Register: **Subordinate bus number**  
 Offset: 1Ah  
 Type: Read/Write  
 Default: 00h

## 4.18 CardBus Latency Timer Register

The CardBus latency timer register is programmed by the host system to specify the latency timer for the PCI6x20 CardBus interface, in units of CCLK cycles. When the PCI6x20 device is a CardBus initiator and asserts  $\overline{CFRAME}$ , the CardBus latency timer begins counting. If the latency timer expires before the PCI6x20 transaction has terminated, then the PCI6x20 device terminates the transaction at the end of the next data phase. A recommended minimum value for this register of 20h allows most transactions to be completed.

| Bit     | 7                     | 6  | 5  | 4  | 3  | 2  | 1  | 0  |
|---------|-----------------------|----|----|----|----|----|----|----|
| Name    | CardBus latency timer |    |    |    |    |    |    |    |
| Type    | RW                    | RW | RW | RW | RW | RW | RW | RW |
| Default | 0                     | 0  | 0  | 0  | 0  | 0  | 0  | 0  |

Register: **CardBus latency timer**  
 Offset: 1Bh (Functions 0, 1)  
 Type: Read/Write  
 Default: 00h

## 4.19 CardBus Memory Base Registers 0, 1

These registers indicate the lower address of a PCI memory address range. They are used by the PCI6x20 device to determine when to forward a memory transaction to the CardBus bus, and likewise, when to forward a CardBus cycle to PCI. Bits 31–12 of these registers are read/write and allow the memory base to be located anywhere in the 32-bit PCI memory space on 4-Kbyte boundaries. Bits 11–0 are read-only and always return 0s. Writes to these bits have no effect. Bits 8 and 9 of the bridge control register (PCI offset 3Eh, see Section 4.25) specify whether memory windows 0 and 1 are prefetchable or nonprefetchable. The memory base register or the memory limit register must be nonzero in order for the PCI6x20 device to claim any memory transactions through CardBus memory windows (i.e., these windows by default are not enabled to pass the first 4 Kbytes of memory to CardBus).

| Bit     | 31                         | 30 | 29 | 28 | 27 | 26 | 25 | 24 | 23 | 22 | 21 | 20 | 19 | 18 | 17 | 16 |
|---------|----------------------------|----|----|----|----|----|----|----|----|----|----|----|----|----|----|----|
| Name    | Memory base registers 0, 1 |    |    |    |    |    |    |    |    |    |    |    |    |    |    |    |
| Type    | RW                         | RW | RW | RW | RW | RW | RW | RW | RW | RW | RW | RW | RW | RW | RW | RW |
| Default | 0                          | 0  | 0  | 0  | 0  | 0  | 0  | 0  | 0  | 0  | 0  | 0  | 0  | 0  | 0  | 0  |
| Bit     | 15                         | 14 | 13 | 12 | 11 | 10 | 9  | 8  | 7  | 6  | 5  | 4  | 3  | 2  | 1  | 0  |
| Name    | Memory base registers 0, 1 |    |    |    |    |    |    |    |    |    |    |    |    |    |    |    |
| Type    | RW                         | RW | RW | RW | R  | R  | R  | R  | R  | R  | R  | R  | R  | R  | R  | R  |
| Default | 0                          | 0  | 0  | 0  | 0  | 0  | 0  | 0  | 0  | 0  | 0  | 0  | 0  | 0  | 0  | 0  |

Register: **Memory base registers 0, 1**  
 Offset: 1Ch, 24h  
 Type: Read-only, Read/Write  
 Default: 0000 0000h

## 4.20 CardBus Memory Limit Registers 0, 1

These registers indicate the upper address of a PCI memory address range. They are used by the PCI6x20 device to determine when to forward a memory transaction to the CardBus bus, and likewise, when to forward a CardBus cycle to PCI. Bits 31–12 of these registers are read/write and allow the memory base to be located anywhere in the 32-bit PCI memory space on 4-Kbyte boundaries. Bits 11–0 are read-only and always return 0s. Writes to these bits have no effect. Bits 8 and 9 of the bridge control register (PCI offset 3Eh, see Section 4.25) specify whether memory windows 0 and 1 are prefetchable or nonprefetchable. The memory base register or the memory limit register must be nonzero in order for the PCI6x20 device to claim any memory transactions through CardBus memory windows (i.e., these windows by default are not enabled to pass the first 4 Kbytes of memory to CardBus).

| Bit            | 31                          | 30 | 29 | 28 | 27 | 26 | 25 | 24 | 23 | 22 | 21 | 20 | 19 | 18 | 17 | 16 |
|----------------|-----------------------------|----|----|----|----|----|----|----|----|----|----|----|----|----|----|----|
| <b>Name</b>    | Memory limit registers 0, 1 |    |    |    |    |    |    |    |    |    |    |    |    |    |    |    |
| <b>Type</b>    | RW                          | RW | RW | RW | RW | RW | RW | RW | RW | RW | RW | RW | RW | RW | RW | RW |
| <b>Default</b> | 0                           | 0  | 0  | 0  | 0  | 0  | 0  | 0  | 0  | 0  | 0  | 0  | 0  | 0  | 0  | 0  |
| Bit            | 15                          | 14 | 13 | 12 | 11 | 10 | 9  | 8  | 7  | 6  | 5  | 4  | 3  | 2  | 1  | 0  |
| <b>Name</b>    | Memory limit registers 0, 1 |    |    |    |    |    |    |    |    |    |    |    |    |    |    |    |
| <b>Type</b>    | RW                          | RW | RW | RW | R  | R  | R  | R  | R  | R  | R  | R  | R  | R  | R  | R  |
| <b>Default</b> | 0                           | 0  | 0  | 0  | 0  | 0  | 0  | 0  | 0  | 0  | 0  | 0  | 0  | 0  | 0  | 0  |

Register: **Memory limit registers 0, 1**  
 Offset: 20h, 28h  
 Type: Read-only, Read/Write  
 Default: 0000 0000h

## 4.21 CardBus I/O Base Registers 0, 1

These registers indicate the lower address of a PCI I/O address range. They are used by the PCI6x20 device to determine when to forward an I/O transaction to the CardBus bus, and likewise, when to forward a CardBus cycle to the PCI bus. The lower 16 bits of this register locate the bottom of the I/O window within a 64-Kbyte page. The upper 16 bits (31–16) are all 0s, which locates this 64-Kbyte page in the first page of the 32-bit PCI I/O address space. Bits 31–2 are read/write and always return 0s forcing I/O windows to be aligned on a natural doubleword boundary in the first 64-Kbyte page of PCI I/O address space. Bits 1–0 are read-only, returning 00 or 01 when read, depending on the value of bit 11 (IO\_BASE\_SEL) in the general control register (PCI offset 86h, see Section 4.31). These I/O windows are enabled when either the I/O base register or the I/O limit register is nonzero. The I/O windows by default are not enabled to pass the first doubleword of I/O to CardBus.

Either the I/O base register or the I/O limit register must be nonzero to enable any I/O transactions.

| Bit            | 31                      | 30 | 29 | 28 | 27 | 26 | 25 | 24 | 23 | 22 | 21 | 20 | 19 | 18 | 17 | 16 |
|----------------|-------------------------|----|----|----|----|----|----|----|----|----|----|----|----|----|----|----|
| <b>Name</b>    | I/O base registers 0, 1 |    |    |    |    |    |    |    |    |    |    |    |    |    |    |    |
| <b>Type</b>    | RW                      | RW | RW | RW | RW | RW | RW | RW | RW | RW | RW | RW | RW | RW | RW | RW |
| <b>Default</b> | 0                       | 0  | 0  | 0  | 0  | 0  | 0  | 0  | 0  | 0  | 0  | 0  | 0  | 0  | 0  | 0  |
| Bit            | 15                      | 14 | 13 | 12 | 11 | 10 | 9  | 8  | 7  | 6  | 5  | 4  | 3  | 2  | 1  | 0  |
| <b>Name</b>    | I/O base registers 0, 1 |    |    |    |    |    |    |    |    |    |    |    |    |    |    |    |
| <b>Type</b>    | RW                      | RW | RW | RW | RW | RW | RW | RW | RW | RW | RW | RW | RW | RW | R  | R  |
| <b>Default</b> | 0                       | 0  | 0  | 0  | 0  | 0  | 0  | 0  | 0  | 0  | 0  | 0  | 0  | 0  | 0  | X  |

Register: **I/O base registers 0, 1**  
 Offset: 2Ch, 34h  
 Type: Read-only, Read/Write  
 Default: 0000 000Xh

## 4.22 CardBus I/O Limit Registers 0, 1

These registers indicate the upper address of a PCI I/O address range. They are used by the PCI6x20 device to determine when to forward an I/O transaction to the CardBus bus, and likewise, when to forward a CardBus cycle to PCI. The lower 16 bits of this register locate the top of the I/O window within a 64-Kbyte page, and the upper 16 bits are a page register which locates this 64-Kbyte page in 32-bit PCI I/O address space. Bits 15–2 are read/write and allow the I/O limit address to be located anywhere in the 64-Kbyte page (indicated by bits 31–16 of the appropriate I/O base register) on doubleword boundaries.

Bits 31–16 are read-only and always return 0s when read. The page is set in the I/O base register. Bits 15–2 are read/write and bits 1–0 are read-only, returning 00 or 01 when read, depending on the value of bit 12 (IO\_LIMIT\_SEL) in the general control register (PCI offset 86h, see Section 4.31). Writes to read-only bits have no effect.

These I/O windows are enabled when either the I/O base register or the I/O limit register is nonzero. By default, the I/O windows are not enabled to pass the first doubleword of I/O to CardBus.

Either the I/O base register or the I/O limit register must be nonzero to enable any I/O transactions.

| Bit            | 31                       | 30 | 29 | 28 | 27 | 26 | 25 | 24 | 23 | 22 | 21 | 20 | 19 | 18 | 17 | 16 |
|----------------|--------------------------|----|----|----|----|----|----|----|----|----|----|----|----|----|----|----|
| <b>Name</b>    | I/O limit registers 0, 1 |    |    |    |    |    |    |    |    |    |    |    |    |    |    |    |
| <b>Type</b>    | R                        | R  | R  | R  | R  | R  | R  | R  | R  | R  | R  | R  | R  | R  | R  | R  |
| <b>Default</b> | 0                        | 0  | 0  | 0  | 0  | 0  | 0  | 0  | 0  | 0  | 0  | 0  | 0  | 0  | 0  | 0  |
| Bit            | 15                       | 14 | 13 | 12 | 11 | 10 | 9  | 8  | 7  | 6  | 5  | 4  | 3  | 2  | 1  | 0  |
| <b>Name</b>    | I/O limit registers 0, 1 |    |    |    |    |    |    |    |    |    |    |    |    |    |    |    |
| <b>Type</b>    | RW                       | RW | RW | RW | RW | RW | RW | RW | RW | RW | RW | RW | RW | RW | R  | R  |
| <b>Default</b> | 0                        | 0  | 0  | 0  | 0  | 0  | 0  | 0  | 0  | 0  | 0  | 0  | 0  | 0  | 0  | X  |

Register: **I/O limit registers 0, 1**  
 Offset: 30h, 38h  
 Type: Read-only, Read/Write  
 Default: 0000 000Xh

## 4.23 Interrupt Line Register

The interrupt line register is a read/write register used by the host software. As part of the interrupt routing procedure, the host software writes this register with the value of the system IRQ assigned to the function.

| Bit            | 7              | 6  | 5  | 4  | 3  | 2  | 1  | 0  |
|----------------|----------------|----|----|----|----|----|----|----|
| <b>Name</b>    | Interrupt line |    |    |    |    |    |    |    |
| <b>Type</b>    | RW             | RW | RW | RW | RW | RW | RW | RW |
| <b>Default</b> | 1              | 1  | 1  | 1  | 1  | 1  | 1  | 1  |

Register: **Interrupt line**  
 Offset: 3Ch  
 Type: Read/Write  
 Default: FFh

## 4.24 Interrupt Pin Register

The value read from this register is function dependent. The default value for function 0 is 01h ( $\overline{\text{INTA}}$ ), and the default value for function 1 is 02h ( $\overline{\text{INTB}}$ ), and the default value for function 2 is 03h ( $\overline{\text{INTC}}$ ). The value also depends on the values of bits 28, the tie-all bit (TIEALL), and 29, the interrupt tie bit (INTRTIE), in the system control register (PCI offset 80h, see Section 4.29). The INTRTIE bit is compatible with previous TI CardBus controllers, and when set to 1, ties  $\overline{\text{INTB}}$  to  $\overline{\text{INTA}}$  internally. The TIEALL bit ties  $\overline{\text{INTA}}$ ,  $\overline{\text{INTB}}$ , and  $\overline{\text{INTC}}$  together internally. The internal interrupt connections set by INTRTIE and TIEALL are communicated to host software through this standard register interface. This read-only register is described for all PCI16x20 functions in Table 4–6.

PCI function 0

| Bit     | 7                              | 6 | 5 | 4 | 3 | 2 | 1 | 0 |
|---------|--------------------------------|---|---|---|---|---|---|---|
| Name    | Interrupt pin – PCI function 0 |   |   |   |   |   |   |   |
| Type    | R                              | R | R | R | R | R | R | R |
| Default | 0                              | 0 | 0 | 0 | 0 | 0 | 0 | 1 |

PCI function 1

| Bit     | 7                              | 6 | 5 | 4 | 3 | 2 | 1 | 0 |
|---------|--------------------------------|---|---|---|---|---|---|---|
| Name    | Interrupt pin – PCI function 1 |   |   |   |   |   |   |   |
| Type    | R                              | R | R | R | R | R | R | R |
| Default | 0                              | 0 | 0 | 0 | 0 | 0 | 1 | 0 |

PCI function 2

| Bit     | 7                              | 6 | 5 | 4 | 3 | 2 | 1 | 0 |
|---------|--------------------------------|---|---|---|---|---|---|---|
| Name    | Interrupt pin – PCI function 2 |   |   |   |   |   |   |   |
| Type    | R                              | R | R | R | R | R | R | R |
| Default | 0                              | 0 | 0 | 0 | 0 | 0 | 1 | 1 |

Register: **Interrupt pin**

Offset: 3Dh

Type: Read-only

Default: 01h (function 0), 02h (function 1), 03h (function 2)

**Table 4–6. Interrupt Pin Register Cross Reference**

| INTRTIE BIT<br>(BIT 29, OFFSET 80h) | TIEALL BIT<br>(BIT 28, OFFSET 80h) | INTPIN<br>FUNCTION 0<br>(CARDBUS) | INTPIN<br>FUNCTION 1<br>(DEDICATED SOCKET) |
|-------------------------------------|------------------------------------|-----------------------------------|--|
| 0                                   | 0                                  | 01h ( $\overline{\text{INTA}}$ )  | 02h ( $\overline{\text{INTB}}$ )           |
| 1                                   | 0                                  | 01h ( $\overline{\text{INTA}}$ )  | 01h ( $\overline{\text{INTA}}$ )           |
| X                                   | 1                                  | 01h ( $\overline{\text{INTA}}$ )  | 01h ( $\overline{\text{INTA}}$ )           |

## 4.25 Bridge Control Register

The bridge control register provides control over various PCI6x20 bridging functions. Some bits in this register are global in nature and must be accessed only through function 0. See Table 4–7 for a complete description of the register contents.

| Bit     | 15             | 14 | 13 | 12 | 11 | 10 | 9  | 8  | 7  | 6  | 5  | 4 | 3  | 2  | 1  | 0  |
|---------|----------------|----|----|----|----|----|----|----|----|----|----|---|----|----|----|----|
| Name    | Bridge control |    |    |    |    |    |    |    |    |    |    |   |    |    |    |    |
| Type    | R              | R  | R  | R  | R  | RW | RW | RW | RW | RW | RW | R | RW | RW | RW | RW |
| Default | 0              | 0  | 0  | 0  | 0  | 0  | 1  | 1  | 0  | 1  | 0  | 0 | 0  | 0  | 0  | 0  |

Register: **Bridge control**  
 Offset: 3Eh (Function 0, 1)  
 Type: Read-only, Read/Write  
 Default: 0340h

**Table 4–7. Bridge Control Register Description**

| BIT   | SIGNAL    | TYPE | FUNCTION   |
|-------|-----------|------|--|
| 15–11 | RSVD      | R    | These bits return 0s when read.  |
| 10    | POSTEN    | RW   | Write posting enable. Enables write posting to and from the CardBus sockets. Write posting enables the posting of write data on burst cycles. Operating with write posting disabled impairs performance on burst cycles. Note that burst write data can be posted, but various write transactions may not. This bit is socket dependent and is not shared between functions 0 and 1.   |
| 9     | PREFETCH1 | RW   | Memory window 1 type. This bit specifies whether or not memory window 1 is prefetchable. This bit is socket dependent. This bit is encoded as:<br>0 = Memory window 1 is nonprefetchable.<br>1 = Memory window 1 is prefetchable (default).  |
| 8     | PREFETCH0 | RW   | Memory window 0 type. This bit specifies whether or not memory window 0 is prefetchable. This bit is socket dependent. This bit is encoded as:<br>0 = Memory window 0 is nonprefetchable.<br>1 = Memory window 0 is prefetchable (default).  |
| 7     | INTR      | RW   | PCI interrupt – IREQ routing enable. This bit is used to select whether PC Card functional interrupts are routed to PCI interrupts or to the IRQ specified in the ExCA registers.<br>0 = Functional interrupts are routed to PCI interrupts (default).<br>1 = Functional interrupts are routed by ExCA registers.  |
| 6 †   | CRST      | RW   | CardBus reset. When this bit is set, the $\overline{CRST}$ signal is asserted on the CardBus interface. The $\overline{CRST}$ signal can also be asserted by passing a $\overline{PRST}$ assertion to CardBus.<br>0 = $\overline{CRST}$ is deasserted.<br>1 = $\overline{CRST}$ is asserted (default).<br>This bit is not cleared by the assertion of $\overline{PRST}$ . It is only cleared by the assertion of $\overline{GRST}$ . |
| 5     | MABTMODE  | RW   | Master abort mode. This bit controls how the PCI6x20 device responds to a master abort when the PCI6x20 device is an initiator on the CardBus interface. This bit is common between each socket.<br>0 = Master aborts not reported (default).<br>1 = Signal target abort on PCI and signal $\overline{SERR}$ , if enabled.   |
| 4     | RSVD      | R    | This bit returns 0 when read.  |
| 3     | VGAEN     | RW   | VGA enable. This bit affects how the PCI6x20 device responds to VGA addresses. When this bit is set, accesses to VGA addresses are forwarded.  |
| 2     | ISAEN     | RW   | ISA mode enable. This bit affects how the PCI6x20 device passes I/O cycles within the 64-Kbyte ISA range. This bit is not common between sockets. When this bit is set, the PCI6x20 device does not forward the last 768 bytes of each 1K I/O range to CardBus.  |
| 1     | CSERREN   | RW   | $\overline{CSERR}$ enable. This bit controls the response of the PCI6x20 device to $\overline{CSERR}$ signals on the CardBus bus. This bit is separate for each socket.<br>0 = $\overline{CSERR}$ is not forwarded to PCI $\overline{SERR}$ (default)<br>1 = $\overline{CSERR}$ is forwarded to PCI $\overline{SERR}$ .  |

† One or more bits in this register are PME context bits and can be cleared only by the assertion of  $\overline{GRST}$  when  $\overline{PME}$  is enabled. If  $\overline{PME}$  is not enabled, then this bit is cleared by the assertion of  $\overline{PRST}$  or  $\overline{GRST}$ .

**Table 4–7. Bridge Control Register Description (Continued)**

| BIT | SIGNAL  | TYPE | FUNCTION   |
|-----|---------|------|--|
| 0   | CPERREN | RW   | CardBus parity error response enable. This bit controls the response of the PCI6x20 to CardBus parity errors. This bit is separate for each socket.<br>0 = CardBus parity errors are ignored (default).<br>1 = CardBus parity errors are reported using <u>CPERR</u> . |

#### 4.26 Subsystem Vendor ID Register

The subsystem vendor ID register, used for system and option card identification purposes, may be required for certain operating systems. This register is read-only or read/write, depending on the setting of bit 5 (SUBSYSRW) in the system control register (PCI offset 80h, See Section 4.29). When bit 5 is 0, this register is read/write; when bit 5 is 1, this register is read-only. The default mode is read-only. All bits in this register are reset by  $\overline{\text{GRST}}$  only.

| Bit            | 15                  | 14 | 13 | 12 | 11 | 10 | 9 | 8 | 7 | 6 | 5 | 4 | 3 | 2 | 1 | 0 |
|----------------|---------------------|----|----|----|----|----|---|---|---|---|---|---|---|---|---|---|
| <b>Name</b>    | Subsystem vendor ID |    |    |    |    |    |   |   |   |   |   |   |   |   |   |   |
| <b>Type</b>    | R                   | R  | R  | R  | R  | R  | R | R | R | R | R | R | R | R | R | R |
| <b>Default</b> | 0                   | 0  | 0  | 0  | 0  | 0  | 0 | 0 | 0 | 0 | 0 | 0 | 0 | 0 | 0 | 0 |

Register: **Subsystem vendor ID**  
 Offset: 40h (Functions 0, 1)  
 Type: Read-only, (Read/Write when bit 5 in the system control register is 0)  
 Default: 0000h

#### 4.27 Subsystem ID Register

The subsystem ID register, used for system and option card identification purposes, may be required for certain operating systems. This register is read-only or read/write, depending on the setting of bit 5 (SUBSYSRW) in the system control register (PCI offset 80h, see Section 4.29). When bit 5 is 0, this register is read/write; when bit 5 is 1, this register is read-only. The default mode is read-only. All bits in this register are reset by  $\overline{\text{GRST}}$  only.

If an EEPROM is present, then the subsystem ID and subsystem vendor ID is loaded from the EEPROM after a reset.

| Bit            | 15           | 14 | 13 | 12 | 11 | 10 | 9 | 8 | 7 | 6 | 5 | 4 | 3 | 2 | 1 | 0 |
|----------------|--------------|----|----|----|----|----|---|---|---|---|---|---|---|---|---|---|
| <b>Name</b>    | Subsystem ID |    |    |    |    |    |   |   |   |   |   |   |   |   |   |   |
| <b>Type</b>    | R            | R  | R  | R  | R  | R  | R | R | R | R | R | R | R | R | R | R |
| <b>Default</b> | 0            | 0  | 0  | 0  | 0  | 0  | 0 | 0 | 0 | 0 | 0 | 0 | 0 | 0 | 0 | 0 |

Register: **Subsystem ID**  
 Offset: 42h (Functions 0, 1)  
 Type: Read-only, (Read/Write when bit 5 in the system control register is 0)  
 Default: 0000h

## 4.28 PC Card 16-Bit I/F Legacy-Mode Base-Address Register

The PCI6x20 device supports the index/data scheme of accessing the ExCA registers, which is mapped by this register. An address written to this register is the address for the index register and the address+1 is the data address. Using this access method, applications requiring index/data ExCA access can be supported. The base address can be mapped anywhere in 32-bit I/O space on a word boundary; hence, bit 0 is read-only, returning 1 when read. As specified in the *PCI to PCMCIA CardBus Bridge Register Description* specification, this register is shared by functions 0 and 1. See the ExCA register set description in Section 5 for register offsets. All bits in this register are reset by  $\overline{\text{GRST}}$  only.

|                |   |    |    |    |    |    |    |    |    |    |    |    |    |    |    |    |
|----------------|---|----|----|----|----|----|----|----|----|----|----|----|----|----|----|----|
| <b>Bit</b>     | 31  | 30 | 29 | 28 | 27 | 26 | 25 | 24 | 23 | 22 | 21 | 20 | 19 | 18 | 17 | 16 |
| <b>Name</b>    | PC Card 16-bit I/F legacy-mode base-address |    |    |    |    |    |    |    |    |    |    |    |    |    |    |    |
| <b>Type</b>    | RW  | RW | RW | RW | RW | RW | RW | RW | RW | RW | RW | RW | RW | RW | RW | RW |
| <b>Default</b> | 0   | 0  | 0  | 0  | 0  | 0  | 0  | 0  | 0  | 0  | 0  | 0  | 0  | 0  | 0  | 0  |
| <b>Bit</b>     | 15  | 14 | 13 | 12 | 11 | 10 | 9  | 8  | 7  | 6  | 5  | 4  | 3  | 2  | 1  | 0  |
| <b>Name</b>    | PC Card 16-bit I/F legacy-mode base-address |    |    |    |    |    |    |    |    |    |    |    |    |    |    |    |
| <b>Type</b>    | RW  | RW | RW | RW | RW | RW | RW | RW | RW | RW | RW | RW | RW | RW | RW | R  |
| <b>Default</b> | 0   | 0  | 0  | 0  | 0  | 0  | 0  | 0  | 0  | 0  | 0  | 0  | 0  | 0  | 0  | 1  |

Register: **PC Card 16-bit I/F legacy-mode base-address**  
 Offset: 44h (Functions 0, 1)  
 Type: Read-only, Read/Write  
 Default: 0000 0001h

## 4.29 System Control Register

System-level initializations are performed through programming this doubleword register. Some of the bits are global in nature and must be accessed only through function 0. See Table 4–8 for a complete description of the register contents.

| Bit     | 31             | 30 | 29 | 28 | 27 | 26 | 25 | 24 | 23 | 22 | 21 | 20 | 19 | 18 | 17 | 16 |
|---------|----------------|----|----|----|----|----|----|----|----|----|----|----|----|----|----|----|
| Name    | System control |    |    |    |    |    |    |    |    |    |    |    |    |    |    |    |
| Type    | RW             | RW | RW | RW | R  | RW | RW | RW | R  | RW | RW | RW | RW | RW | RW | RW |
| Default | 0              | 0  | 0  | 0  | 1  | 0  | 0  | 0  | 0  | 0  | 0  | 0  | 0  | 0  | 0  | 0  |
| Bit     | 15             | 14 | 13 | 12 | 11 | 10 | 9  | 8  | 7  | 6  | 5  | 4  | 3  | 2  | 1  | 0  |
| Name    | System control |    |    |    |    |    |    |    |    |    |    |    |    |    |    |    |
| Type    | RW             | RW | R  | R  | R  | R  | R  | R  | R  | RW | RW | RW | RW | R  | RW | RW |
| Default | 1              | 0  | 0  | 1  | 0  | 0  | 0  | 0  | 0  | 1  | 1  | 0  | 0  | 0  | 0  | 0  |

Register: **System control**  
 Offset: 80h (Functions 0, 1)  
 Type: Read-only, Read/Write  
 Default: 0800 9060h

**Table 4–8. System Control Register Description**

| BIT      | SIGNAL    | TYPE | FUNCTION   |
|----------|-----------|------|--|
| 31–30 ‡§ | SER_STEP  | RW   | Serial input stepping. In serial PCI interrupt mode, these bits are used to configure the serial stream PCI interrupt frames, and can be used to accomplish an even distribution of interrupts signaled on the four PCI interrupt slots.<br>00 = $\overline{INTA}/\overline{INTB}/\overline{INTC}$ signal in $\overline{INTA}/\overline{INTB}/\overline{INTC}$ slots (default)<br>01 = $\overline{INTA}/\overline{INTB}/\overline{INTC}$ signal in $\overline{INTB}/\overline{INTC}/\overline{INTD}$ slots<br>10 = $\overline{INTA}/\overline{INTB}/\overline{INTC}$ signal in $\overline{INTC}/\overline{INTD}/\overline{INTA}$ slots<br>11 = $\overline{INTA}/\overline{INTB}/\overline{INTC}$ signal in $\overline{INTD}/\overline{INTA}/\overline{INTB}$ slots |
| 29 ‡§    | INTRTIE   | RW   | This bit ties $\overline{INTA}$ to $\overline{INTB}$ internally (to $\overline{INTA}$ ), and reports this through the interrupt pin register (PCI offset 3Dh, see Section 4.24). This bit has no effect on $\overline{INTC}$ or $\overline{INTD}$ .  |
| 28 ‡     | TIEALL    | RW   | This bit ties $\overline{INTA}$ , $\overline{INTB}$ , and $\overline{INTC}$ internally (to $\overline{INTA}$ ), and reports this through the interrupt pin register (PCI offset 3Dh, see Section 4.24).  |
| 27 ‡     | PSCCLK    | RW   | P2C power switch clock. The PCI6x20 CLOCK signal clocks the serial interface power switch and the internal state machine. The default state for this bit is 1, allowing the internal oscillator to provide the clock signal. Bit 27 can be set to 0, requiring an external clock source provided to the CLOCK terminal.<br>0 = CLOCK is provided externally, input to the PCI6x20 device.<br>1 = CLOCK is generated by the internal oscillator and driven by the PCI6x20 device. (default)   |
| 26 ‡§    | SMIROUTE  | RW   | SMI interrupt routing. This bit is shared between functions 0 and 1, and selects whether IRQ2 or CSC is signaled when a write occurs to power a PC Card socket.<br>0 = PC Card power change interrupts are routed to IRQ2 (default).<br>1 = A CSC interrupt is generated on PC Card power changes.   |
| 25 ‡     | SMISTATUS | RW   | SMI interrupt status. This socket-dependent bit is set when a write occurs to set the socket power, and the SMIENB bit is set. Writing a 1 to this bit clears the status.<br>0 = SMI interrupt is signaled.<br>1 = SMI interrupt is not signaled.  |
| 24 ‡§    | SMIENB    | RW   | SMI interrupt mode enable. When this bit is set, the SMI interrupt signaling generates an interrupt when a write to the socket power control occurs. This bit is shared and defaults to 0 (disabled).<br>0 = SMI interrupt mode is disabled (default).<br>1 = SMI interrupt mode is enabled.   |
| 23       | RSVD      | R    | Reserved   |

‡ One or more bits in this register are cleared only by the assertion of  $\overline{GRST}$ .

§ These bits are global in nature and must be accessed only through function 0.

**Table 4–8. System Control Register Description (continued)**

| BIT     | SIGNAL      | TYPE | FUNCTION  |
|---------|-------------|------|---|
| 22 ‡    | CBRSVD      | RW   | CardBus reserved terminals signaling. When this bit is set, the RSVD CardBus terminals are driven low when a CardBus card has been inserted. When this bit is low, these signals are placed in a high-impedance state.<br>0 = Place the CardBus RSVD terminals in a high-impedance state.<br>1 = Drive the CardBus RSVD terminals low (default).        |
| 21 ‡    | VCCPROT     | RW   | V <sub>CC</sub> protection enable. This bit is socket dependent.<br>0 = V <sub>CC</sub> protection is enabled for 16-bit cards (default).<br>1 = V <sub>CC</sub> protection is disabled for 16-bit cards.   |
| 20–16 ‡ | RSVD        | RW   | on $\overline{\text{INTC}}$ or $\overline{\text{INTD}}$ .   |
| 15 ‡§   | MRBURSTDN   | RW   | Memory read burst enable downstream. When this bit is set, the PCI6x20 device allows memory read transactions to burst downstream.<br>0 = MRBURSTDN downstream is disabled.<br>1 = MRBURSTDN downstream is enabled (default).   |
| 14 ‡§   | MRBURSTUP   | RW   | Memory read burst enable upstream. When this bit is set, the PCI6x20 device allows memory read transactions to burst upstream.<br>0 = MRBURSTUP upstream is disabled (default).<br>1 = MRBURSTUP upstream is enabled.   |
| 13 ‡    | SOCACTIVE   | R    | Socket activity status. When set, this bit indicates access has been performed to or from a PC Card. Reading this bit causes it to be cleared. This bit is socket dependent.<br>0 = No socket activity (default)<br>1 = Socket activity   |
| 12      | RSVD        | R    | Reserved. This bit returns 1 when read.   |
| 11 ‡    | PWRSTREAM   | R    | Power-stream-in-progress status bit. When set, this bit indicates that a power stream to the power switch is in progress and a powering change has been requested. When this bit is cleared, it indicates that the power stream is complete.<br>0 = Power stream is complete, delay has expired (default).<br>1 = Power stream is in progress.          |
| 10 †    | DELAYUP     | R    | Power-up delay-in-progress status bit. When set, this bit indicates that a power-up stream has been sent to the power switch, and proper power may not yet be stable. This bit is cleared when the power-up delay has expired.<br>0 = Power-up delay has expired (default).<br>1 = Power-up stream sent to switch. Power might not be stable.           |
| 9 †     | DELAYDOWN   | R    | Power-down delay-in-progress status bit. When set, this bit indicates that a power-down stream has been sent to the power switch, and proper power may not yet be stable. This bit is cleared when the power-down delay has expired.<br>0 = Power-down delay has expired (default).<br>1 = Power-down stream sent to switch. Power might not be stable. |
| 8 †     | INTERROGATE | R    | Interrogation in progress. When set, this bit indicates an interrogation is in progress, and clears when the interrogation completes. This bit is socket-dependent.<br>0 = Interrogation not in progress (default)<br>1 = Interrogation in progress   |
| 7       | RSVD        | R    | Reserved. This bit returns 0 when read.   |
| 6 ‡§    | PWRSAVINGS  | RW   | Power savings mode enable. When this bit is set, the PCI6x20 device consumes less power with no performance loss. This bit is shared between the two PCI6x20 CardBus functions.<br>0 = Power savings mode disabled<br>1 = Power savings mode enabled (default)  |
| 5 ‡§    | SUBSYSRW    | RW   | Subsystem ID and subsystem vendor ID, ExCA ID and revision register read/write enable. This bit also controls read/write for the function 3 subsystem ID register.<br>0 = Registers are read/write.<br>1 = Registers are read-only (default).   |

† One or more bits in this register are PME context bits and can be cleared only by the assertion of  $\overline{\text{GRST}}$  when  $\overline{\text{PME}}$  is enabled. If  $\overline{\text{PME}}$  is not enabled, then this bit is cleared by the assertion of  $\overline{\text{PRST}}$  or  $\overline{\text{GRST}}$ .

‡ One or more bits in this register are cleared only by the assertion of  $\overline{\text{GRST}}$ .

§ These bits are global in nature and must be accessed only through function 0.

**Table 4–8. System Control Register Description (continued)**

| BIT  | SIGNAL    | TYPE | FUNCTION  |
|------|-----------|------|---|
| 4 ‡§ | CB_DPAR   | RW   | CardBus data parity SERR signaling enable.<br>0 = CardBus data parity not signaled on PCI $\overline{\text{SERR}}$ signal (default)<br>1 = CardBus data parity signaled on PCI $\overline{\text{SERR}}$ signal  |
| 3 ‡§ | RSVD      | R    | Reserved. This bit returns 0 when read.   |
| 2 ‡  | EXCAPOWER | R    | ExCA power control bit.<br>0 = Enables 3.3 V (default)<br>1 = Enables 5 V   |
| 1 ‡§ | KEEPCLK   | RW   | Keep clock. When this bit is set, the PCI6x20 device follows the $\overline{\text{CLKRUN}}$ protocol to maintain the system PCLK and the CCLK (CardBus clock). This bit is global to the PCI6x20 functions.<br>0 = Allow system PCLK and CCLK clocks to stop (default)<br>1 = Never allow system PCLK or CCLK clock to stop<br><br>Note that the functionality of this bit has changed relative to that of the PCI12XX family of TI CardBus controllers. In these CardBus controllers, setting this bit only maintains the PCI clock, not the CCLK. In the PCI6x20 device, setting this bit maintains both the PCI clock and the CCLK.  |
| 0 ‡§ | RIMUX     | RW   | $\overline{\text{PME/RI\_OUT}}$ select bit. When this bit is 1, the PME signal is routed to the $\overline{\text{PME/RI\_OUT}}$ terminal (R03). When this bit is 0 and bit 7 (RIENB) of the card control register is 1, the RI_OUT signal is routed to the $\overline{\text{PME/RI\_OUT}}$ terminal (R03). If this bit is 0 and bit 7 (RIENB) of the card control register is 0, then the output (R03) is placed in a high-impedance state. This terminal is encoded as:<br>0 = RI_OUT signal is routed to the $\overline{\text{PME/RI\_OUT}}$ terminal (R03) if bit 7 of the card control register is 1. (default)<br>1 = $\overline{\text{PME}}$ signal is routed to the $\overline{\text{PME/RI\_OUT}}$ terminal (R03) of the PCI6x20 controller.<br><br>NOTE: If this bit (bit 0) is 0 and bit 7 of the card control register (PCI offset 91h, see Section 4.38) is 0, then the output on the $\overline{\text{PME/RI\_OUT}}$ terminal (R03) is placed in a high-impedance state. |

‡ One or more bits in this register are cleared only by the assertion of  $\overline{\text{GRST}}$ .

§ These bits are global in nature and must be accessed only through function 0.

### 4.30 MC\_CD Debounce Register

This register provides debounce time in units of 2 ms for the  $\overline{\text{MC\_CD}}$  signal on UltraMedia cards. This register defaults to 19h, which gives a default debounce time of 50 ms. All bits in this register are reset by  $\overline{\text{GRST}}$  only.

| Bit     | 7              | 6  | 5  | 4  | 3  | 2  | 1  | 0  |
|---------|----------------|----|----|----|----|----|----|----|
| Name    | MC_CD debounce |    |    |    |    |    |    |    |
| Type    | RW             | RW | RW | RW | RW | RW | RW | RW |
| Default | 0              | 0  | 0  | 1  | 1  | 0  | 0  | 1  |

Register: **MC\_CD debounce**  
 Offset: 84h (Functions 0, 1)  
 Type: Read/Write  
 Default: 19h

## 4.31 General Control Register

The general control register provides top level PCI arbitration control. See Table 4–9 for a complete description of the register contents.

| Bit     | 15              | 14 | 13 | 12 | 11 | 10 | 9 | 8 | 7 | 6 | 5  | 4  | 3  | 2 | 1  | 0  |
|---------|-----------------|----|----|----|----|----|---|---|---|---|----|----|----|---|----|----|
| Name    | General control |    |    |    |    |    |   |   |   |   |    |    |    |   |    |    |
| Type    | R               | R  | RW | RW | RW | RW | R | R | R | R | RW | RW | RW | R | RW | RW |
| Default | 0               | 0  | 0  | 0  | 0  | 0  | 0 | 0 | 1 | 0 | 0  | 0  | 0  | 0 | 0  | 0  |

Register: **General control**  
 Offset: 86h  
 Type: Read/Write, Read-only  
 Default: 0080h

**Table 4–9. General Control Register Description**

| BIT   | SIGNAL       | TYPE | FUNCTION  |
|-------|--------------|------|---|
| 15–14 | RSVD         | R    | These bits do not affect any functionality within the CardBus core.   |
| 13 ‡  | SIM_MODE     | RW   | When this bit is set, it reduces the query time for UltraMedia card types.<br>0 = Query time is unaffected (default)<br>1 = Query time is reduced for simulation purposes   |
| 12 ‡  | IO_LIMIT_SEL | RW   | When this bit is set, bit 0 in the I/O limit registers (PCI offsets 30h and 38h) for both CardBus functions is set.<br>0 = Bit 0 in the I/O limit registers is 0 (default)<br>1 = Bit 0 in the I/O limit registers is 1 |
| 11 ‡  | IO_BASE_SEL  | RW   | When this bit is set, bit 0 in the I/O base registers (PCI offsets 2Ch and 34h) for both CardBus functions is set.<br>0 = Bit 0 in the I/O base registers is 0 (default)<br>1 = Bit 0 in the I/O base registers is 1    |
| 10 ‡  | 12V_SW_SEL   | RW   | Power switch select. This bit selects which power switch is implemented in the system.<br>0 = A 1.8-V capable power switch (TPS2228) is used (default)<br>1 = A 12-V capable power switch (TPS2226) is used             |
| 9–8   | RSVD         | R    | Reserved. These bits return 0 when read.  |
| 7 ‡   | PCI2_3_EN    | R    | PCI 2.3 enable. The PCI6x20 CardBus functions always conform to the PCI 2.3 specification. Therefore, this bit is tied to 1.  |
| 6     | RSVD         | R    | Reserved. This bit returns 0 when read.   |
| 5 ‡   | DISABLE_FM   | RW   | When this bit is set, the flash media function is completely nonaccessible and nonfunctional.   |
| 4 ‡   | DISABLE_SKTB | RW   | When this bit is set, CardBus socket B (function 1) is completely nonaccessible and nonfunctional.  |
| 3 ‡   | RSVD         | RW   | Reserved. This bit returns 0 when read.   |
| 2     | RSVD         | R    | Reserved. This bit returns 0 when read.   |
| 1–0 ‡ | ARB_CTRL     | RW   | Controls top level PCI arbitration:<br>00 = Reserved<br>01 = CardBus priority<br>10 = Flash media priority<br>11 = Fair round robin   |

‡ One or more bits in this register are cleared only by the assertion of  $\overline{\text{GRST}}$ .

## 4.32 General-Purpose Event Status Register

The general-purpose event status register contains status bits that are set when general events occur, and can be programmed to generate general-purpose event signaling through  $\overline{\text{GPE}}$ . See Table 4–10 for a complete description of the register contents.

| Bit     | 7                            | 6   | 5 | 4   | 3   | 2   | 1   | 0   |
|---------|------------------------------|-----|---|-----|-----|-----|-----|-----|
| Name    | General-purpose event status |     |   |     |     |     |     |     |
| Type    | RCU                          | RCU | R | RCU | RCU | RCU | RCU | RCU |
| Default | 0                            | 0   | 0 | 0   | 0   | 0   | 0   | 0   |

Register: **General-purpose event status**  
 Offset: 88h  
 Type: Read/Clear/Update, Read-only  
 Default: 00h

**Table 4–10. General-Purpose Event Status Register Description**

| BIT | SIGNAL    | TYPE | FUNCTION  |
|-----|-----------|------|---|
| 7 ‡ | PWR_STS   | RCU  | Power change status. This bit is set when software changes the $V_{CC}$ or $V_{PP}$ power state of either socket.                       |
| 6 ‡ | VPP12_STS | RCU  | 12-V $V_{PP}$ request status. This bit is set when software has changed the requested $V_{PP}$ level to or from 12 V for either socket. |
| 5   | RSVD      | R    | Reserved. This bit returns 0 when read. A write has no effect.  |
| 4 ‡ | GP4_STS   | RCU  | GPI4 status. This bit is set on a change in status of the MFUNC5 terminal input level if configured as a general-purpose input, GPI4.   |
| 3 ‡ | GP3_STS   | RCU  | GPI3 status. This bit is set on a change in status of the MFUNC4 terminal input level if configured as a general-purpose input, GPI3.   |
| 2 ‡ | GP2_STS   | RCU  | GPI2 status. This bit is set on a change in status of the MFUNC2 terminal input level if configured as a general-purpose input, GPI2.   |
| 1 ‡ | GP1_STS   | RCU  | GPI1 status. This bit is set on a change in status of the MFUNC1 terminal input level if configured as a general-purpose input, GPI1.   |
| 0 ‡ | GP0_STS   | RCU  | GPI0 status. This bit is set on a change in status of the MFUNC0 terminal input level if configured as a general-purpose input, GPI0.   |

‡ One or more bits in this register are cleared only by the assertion of  $\overline{\text{GRST}}$ .

### 4.33 General-Purpose Event Enable Register

The general-purpose event enable register contains bits that are set to enable  $\overline{\text{GPE}}$  signals. See Table 4–11 for a complete description of the register contents.

| Bit     | 7                            | 6  | 5 | 4  | 3  | 2  | 1  | 0  |
|---------|------------------------------|----|---|----|----|----|----|----|
| Name    | General-purpose event enable |    |   |    |    |    |    |    |
| Type    | RW                           | RW | R | RW | RW | RW | RW | RW |
| Default | 0                            | 0  | 0 | 0  | 0  | 0  | 0  | 0  |

Register: **General-purpose event enable**  
 Offset: 89h  
 Type: Read-only, Read/Write  
 Default: 00h

**Table 4–11. General-Purpose Event Enable Register Description**

| BIT | SIGNAL   | TYPE | FUNCTION   |
|-----|----------|------|--|
| 7 ‡ | PWR_EN   | RW   | Power change $\overline{\text{GPE}}$ enable. When this bit is set, $\overline{\text{GPE}}$ is signaled on PWR_STS events.    |
| 6 ‡ | VPP12_EN | RW   | 12-V $V_{PP}$ $\overline{\text{GPE}}$ enable. When this bit is set, $\overline{\text{GPE}}$ is signaled on VPP12_STS events. |
| 5   | RSVD     | R    | Reserved. This bit returns 0 when read. A write has no effect.   |
| 4 ‡ | GP4_EN   | RW   | GPI4 $\overline{\text{GPE}}$ enable. When this bit is set, $\overline{\text{GPE}}$ is signaled on GP4_STS events.            |
| 3 ‡ | GP3_EN   | RW   | GPI3 $\overline{\text{GPE}}$ enable. When this bit is set, $\overline{\text{GPE}}$ is signaled on GP3_STS events.            |
| 2 ‡ | GP2_EN   | RW   | GPI2 $\overline{\text{GPE}}$ enable. When this bit is set, $\overline{\text{GPE}}$ is signaled on GP2_STS events.            |
| 1 ‡ | GP1_EN   | RW   | GPI1 $\overline{\text{GPE}}$ enable. When this bit is set, $\overline{\text{GPE}}$ is signaled on GP1_STS events.            |
| 0 ‡ | GP0_EN   | RW   | GPI0 $\overline{\text{GPE}}$ enable. When this bit is set, $\overline{\text{GPE}}$ is signaled on GP0_STS events.            |

‡ One or more bits in this register are cleared only by the assertion of  $\overline{\text{GRST}}$ .

### 4.34 General-Purpose Input Register

The general-purpose input register contains the logical value of the data input to the GPI terminals. See Table 4–12 for a complete description of the register contents.

| Bit     | 7                     | 6 | 5 | 4  | 3  | 2  | 1  | 0  |
|---------|-----------------------|---|---|----|----|----|----|----|
| Name    | General-purpose input |   |   |    |    |    |    |    |
| Type    | R                     | R | R | RU | RU | RU | RU | RU |
| Default | 0                     | 0 | 0 | X  | X  | X  | X  | X  |

Register: **General-purpose input**  
 Offset: 8Ah  
 Type: Read/Update, Read-only  
 Default: XXh

**Table 4–12. General-Purpose Input Register Description**

| BIT | SIGNAL    | TYPE | FUNCTION  |
|-----|-----------|------|---|
| 7–5 | RSVD      | R    | Reserved. These bits return 0s when read. Writes have no effect.                    |
| 4   | GPI4_DATA | RU   | GPI4 data input. This bit represents the logical value of the data input from GPI4. |
| 3   | GPI3_DATA | RU   | GPI3 data input. This bit represents the logical value of the data input from GPI3. |
| 2   | GPI2_DATA | RU   | GPI2 data input. This bit represents the logical value of the data input from GPI2. |
| 1   | GPI1_DATA | RU   | GPI1 data input. This bit represents the logical value of the data input from GPI1. |
| 0   | GPI0_DATA | RU   | GPI0 data input. This bit represents the logical value of the data input from GPI0. |

## 4.35 General-Purpose Output Register

The general-purpose output register is used to drive the GPO4–GPO0 outputs. See Table 4–13 for a complete description of the register contents.

| Bit     | 7                      | 6 | 5 | 4  | 3  | 2  | 1  | 0  |
|---------|------------------------|---|---|----|----|----|----|----|
| Name    | General-purpose output |   |   |    |    |    |    |    |
| Type    | R                      | R | R | RW | RW | RW | RW | RW |
| Default | 0                      | 0 | 0 | 0  | 0  | 0  | 0  | 0  |

Register: **General-purpose output**  
 Offset: 8Bh  
 Type: Read-only, Read/Write  
 Default: 00h

**Table 4–13. General-Purpose Output Register Description**

| BIT | SIGNAL    | TYPE | FUNCTION  |
|-----|-----------|------|---|
| 7–5 | RSVD      | R    | Reserved. These bits return 0s when read. Writes have no effect.  |
| 4 ‡ | GPO4_DATA | RW   | This bit represents the logical value of the data driven to GPO4. |
| 3 ‡ | GPO3_DATA | RW   | This bit represents the logical value of the data driven to GPO3. |
| 2 ‡ | GPO2_DATA | RW   | This bit represents the logical value of the data driven to GPO2. |
| 1 ‡ | GPO1_DATA | RW   | This bit represents the logical value of the data driven to GPO1. |
| 0 ‡ | GPO0_DATA | RW   | This bit represents the logical value of the data driven to GPO0. |

‡ One or more bits in this register are cleared only by the assertion of  $\overline{\text{GRST}}$ .

## 4.36 Multifunction Routing Status Register

The multifunction routing status register is used to configure the MFUNC6–MFUNC0 terminals. These terminals may be configured for various functions. This register is intended to be programmed once at power-on initialization. The default value for this register can also be loaded through a serial EEPROM. See Table 4–14 for a complete description of the register contents.

|                |                              |           |           |           |           |           |           |           |           |           |           |           |           |           |           |           |
|----------------|------------------------------|-----------|-----------|-----------|-----------|-----------|-----------|-----------|-----------|-----------|-----------|-----------|-----------|-----------|-----------|-----------|
| <b>Bit</b>     | <b>31</b>                    | <b>30</b> | <b>29</b> | <b>28</b> | <b>27</b> | <b>26</b> | <b>25</b> | <b>24</b> | <b>23</b> | <b>22</b> | <b>21</b> | <b>20</b> | <b>19</b> | <b>18</b> | <b>17</b> | <b>16</b> |
| <b>Name</b>    | Multifunction routing status |           |           |           |           |           |           |           |           |           |           |           |           |           |           |           |
| <b>Type</b>    | R                            | RW        | RW        | RW        | R         | RW        | RW        | RW        | R         | RW        | RW        | RW        | R         | RW        | RW        | RW        |
| <b>Default</b> | 0                            | 0         | 0         | 0         | 0         | 0         | 0         | 0         | 0         | 0         | 0         | 0         | 0         | 0         | 0         | 0         |
| <b>Bit</b>     | <b>15</b>                    | <b>14</b> | <b>13</b> | <b>12</b> | <b>11</b> | <b>10</b> | <b>9</b>  | <b>8</b>  | <b>7</b>  | <b>6</b>  | <b>5</b>  | <b>4</b>  | <b>3</b>  | <b>2</b>  | <b>1</b>  | <b>0</b>  |
| <b>Name</b>    | Multifunction routing status |           |           |           |           |           |           |           |           |           |           |           |           |           |           |           |
| <b>Type</b>    | R                            | RW        | RW        | RW        | R         | RW        | RW        | RW        | R         | RW        | RW        | RW        | R         | RW        | RW        | RW        |
| <b>Default</b> | 0                            | 0         | 0         | 1         | 0         | 0         | 0         | 0         | 0         | 0         | 0         | 0         | 0         | 0         | 0         | 0         |

Register: **Multifunction routing status**  
 Offset: 8Ch  
 Type: Read/Write, Read-only  
 Default: 0000 1000h

**Table 4–14. Multifunction Routing Status Register Description**

| BIT     | SIGNAL | TYPE | FUNCTION  |
|---------|--------|------|---|
| 31–28 ‡ | RSVD   | R    | Bits 31–28 return 0s when read.   |
| 27–24 ‡ | MFUNC6 | RW   | Multifunction terminal 6 configuration. These bits control the internal signal mapped to the MFUNC6 terminal as follows:<br>0000 = <u>RSVD</u> 0100 = IRQ4      1000 = IRQ8      1100 = IRQ12<br>0001 = <u>CLKRUN</u> 0101 = IRQ5      1001 = IRQ9      1101 = IRQ13<br>0010 = IRQ2      0110 = IRQ6      1010 = IRQ10     1110 = IRQ14<br>0011 = IRQ3      0111 = IRQ7      1011 = IRQ11     1111 = IRQ15                          |
| 23–20 ‡ | MFUNC5 | RW   | Multifunction terminal 5 configuration. These bits control the internal signal mapped to the MFUNC5 terminal as follows:<br>0000 = GPI4      0100 = IRQ4      1000 = CAUDPWM    1100 = LEDA1<br>0001 = GPO4      0101 = IRQ5      1001 = IRQ9      1101 = LED_SKT<br>0010 = <u>PCGNT</u> 0110 = RSVD      1010 = IRQ10     1110 = <u>GPE</u><br>0011 = IRQ3      0111 = RSVD      1011 = RSVD      1111 = IRQ15                     |
| 19–16 ‡ | MFUNC4 | RW   | Multifunction terminal 4 configuration. These bits control the internal signal mapped to the MFUNC4 terminal as follows:<br>0000 = GPI3      0100 = IRQ4      1000 = CAUDPWM    1100 = <u>RI_OUT</u><br>0001 = <u>GPO3</u> 0101 = IRQ5      1001 = IRQ9      1101 = <u>LED_SKT</u><br>0010 = <u>LOCK PCI</u> 0110 = RSVD      1010 = RSVD      1110 = <u>GPE</u><br>0011 = IRQ3      0111 = RSVD      1011 = IRQ11     1111 = IRQ15 |
| 15–12 ‡ | MFUNC3 | RW   | Multifunction terminal 3 configuration. These bits control the internal signal mapped to the MFUNC3 terminal as follows:<br>0000 = RSVD      0100 = IRQ4      1000 = IRQ8      1100 = IRQ12<br>0001 = IRQSER    0101 = IRQ5      1001 = IRQ9      1101 = IRQ13<br>0010 = IRQ2      0110 = IRQ6      1010 = IRQ10     1110 = IRQ14<br>0011 = IRQ3      0111 = IRQ7      1011 = IRQ11     1111 = IRQ15                                |
| 11–8 ‡  | MFUNC2 | RW   | Multifunction terminal 2 configuration. These bits control the internal signal mapped to the MFUNC2 terminal as follows:<br>0000 = GPI2      0100 = IRQ4      1000 = CAUDPWM    1100 = <u>RI_OUT</u><br>0001 = GPO2      0101 = IRQ5      1001 = IRQ9      1101 = TEST_MUX<br>0010 = <u>PCREQ</u> 0110 = RSVD      1010 = <u>IRQ10</u> 1110 = <u>GPE</u><br>0011 = IRQ3      0111 = RSVD      1011 = INTC      1111 = IRQ7          |

‡ One or more bits in this register are cleared only by the assertion of GRST.

**Table 4–14. Multifunction Routing Status Register Description (Continued)**

| BIT   | SIGNAL | TYPE | FUNCTION  |
|-------|--------|------|---|
| 7–4 ‡ | MFUNC1 | RW   | Multifunction terminal 1 configuration. These bits control the internal signal mapped to the MFUNC1 terminal as follows:<br>0000 = GPI1      0100 = RSVD      1000 = CAUDPWM      1100 = LEDA1<br>0001 = <u>GPO1</u> 0101 = IRQ5      1001 = IRQ9      1101 = <u>LEDA2</u><br>0010 = <u>INTB</u> 0110 = RSVD      1010 = IRQ10      1110 = <u>GPE</u><br>0011 = IRQ3      0111 = RSVD      1011 = IRQ11      1111 = IRQ15 |
| 3–0 ‡ | MFUNC0 | RW   | Multifunction terminal 0 configuration. These bits control the internal signal mapped to the MFUNC0 terminal as follows:<br>0000 = GPI0      0100 = IRQ4      1000 = CAUDPWM      1100 = LEDA1<br>0001 = <u>GPO0</u> 0101 = IRQ5      1001 = IRQ9      1101 = <u>LEDA2</u><br>0010 = <u>INTA</u> 0110 = RSVD      1010 = IRQ10      1110 = <u>GPE</u><br>0011 = IRQ3      0111 = RSVD      1011 = IRQ11      1111 = IRQ15 |

‡ One or more bits in this register are cleared only by the assertion of  $\overline{\text{GRST}}$ .

### 4.37 Retry Status Register

The contents of the retry status register enable the retry time-out counters and display the retry expiration status. The flags are set when the PCI6x20 device, as a master, receives a retry and does not retry the request within  $2^{15}$  clock cycles. The flags are cleared by writing a 1 to the bit. Access this register only through function 0. See Table 4–15 for a complete description of the register contents.

| Bit            | 7            | 6  | 5  | 4 | 3  | 2 | 1  | 0 |
|----------------|--------------|----|----|---|----|---|----|---|
| <b>Name</b>    | Retry status |    |    |   |    |   |    |   |
| <b>Type</b>    | RW           | RW | RC | R | RC | R | RC | R |
| <b>Default</b> | 1            | 1  | 0  | 0 | 0  | 0 | 0  | 0 |

Register: **Retry status**  
 Offset: 90h (Functions 0, 1)  
 Type: Read-only, Read/Write, Read/Clear  
 Default: C0h

**Table 4–15. Retry Status Register Description**

| BIT  | SIGNAL   | TYPE | FUNCTION  |
|------|----------|------|---|
| 7 ‡  | PCIRETRY | RW   | PCI retry time-out counter enable. This bit is encoded as:<br>0 = PCI retry counter disabled<br>1 = PCI retry counter enabled (default)             |
| 6 ‡§ | CBRETRY  | RW   | CardBus retry time-out counter enable. This bit is encoded as:<br>0 = CardBus retry counter disabled<br>1 = CardBus retry counter enabled (default) |
| 5 ‡  | TEXP_CBB | RC   | CardBus target B retry expired. Write a 1 to clear this bit.<br>0 = Inactive (default)<br>1 = Retry has expired.                                    |
| 4    | RSVD     | R    | Reserved. This bit returns 0 when read.   |
| 3 ‡§ | TEXP_CBA | RC   | CardBus target A retry expired. Write a 1 to clear this bit.<br>0 = Inactive (default)<br>1 = Retry has expired.                                    |
| 2    | RSVD     | R    | Reserved. This bit returns 0 when read.   |
| 1 ‡  | TEXP_PCI | RC   | PCI target retry expired. Write a 1 to clear this bit.<br>0 = Inactive (default)<br>1 = Retry has expired.  |
| 0    | RSVD     | R    | Reserved. This bit returns 0 when read.   |

‡ One or more bits in this register are cleared only by the assertion of  $\overline{\text{GRST}}$ .

§ These bits are global in nature and must be accessed only through function 0.

## 4.38 Card Control Register

The card control register is provided for PCI1130 compatibility. RI\_OUT is enabled through this register, and the enable bit is shared between functions 0 and 1. See Table 4–16 for a complete description of the register contents.

The  $\overline{\text{RI\_OUT}}$  signal is enabled through this register, and the enable bit is shared between functions 0 and 1.

| Bit     | 7            | 6  | 5  | 4 | 3 | 2  | 1  | 0  |
|---------|--------------|----|----|---|---|----|----|----|
| Name    | Card control |    |    |   |   |    |    |    |
| Type    | RW           | RW | RW | R | R | RW | RW | RW |
| Default | 0            | 0  | 0  | 0 | 0 | 0  | 0  | 0  |

Register: **Card control**  
 Offset: 91h  
 Type: Read-only, Read/Write  
 Default: 00h

**Table 4–16. Card Control Register Description**

| BIT  | SIGNAL    | TYPE | FUNCTION   |
|------|-----------|------|--|
| 7 ‡§ | RIENB     | RW   | Ring indicate enable. When this bit is 1, the $\overline{\text{RI\_OUT}}$ output is enabled. This bit defaults to 0.   |
| 6–3  | RSVD      | RW   | These bits are reserved. Do not change the value of these bits.  |
| 2 ‡  | AUD2MUX   | RW   | CardBus audio-to-MFUNC. When this bit is set, the CAUDIO CardBus signal must be routed through an MFUNC terminal. If this bit is set for both functions, then function 0 is routed.<br>0 = CAUDIO set to CAUDPWM on MFUNC terminal (default)<br>1 = CAUDIO is not routed.  |
| 1 ‡  | SPKROUTEN | RW   | When bit 1 is set, the $\overline{\text{SPKR}}$ terminal from the PC Card is enabled and is routed to the SPKROUT terminal. The $\overline{\text{SPKR}}$ signal from socket 0 is XORed with the $\overline{\text{SPKR}}$ signal from socket 1 and sent to SPKROUT. The SPKROUT terminal drives data only when the SPKROUTEN bit of either function is set. This bit is encoded as:<br>0 = $\overline{\text{SPKR}}$ to SPKROUT not enabled (default)<br>1 = $\overline{\text{SPKR}}$ to SPKROUT enabled |
| 0 ‡  | IFG       | RW   | Interrupt flag. This bit is the interrupt flag for 16-bit I/O PC Cards and for CardBus cards. This bit is set when a functional interrupt is signaled from a PC Card interface, and is socket dependent (i.e., not global). Write back a 1 to clear this bit.<br>0 = No PC Card functional interrupt detected (default)<br>1 = PC Card functional interrupt detected   |

‡ One or more bits in this register are cleared only by the assertion of  $\overline{\text{GRST}}$ .

§ This bit is global in nature and must be accessed only through function 0.

## 4.39 Device Control Register

The device control register is provided for PCI1130 compatibility. It contains bits that are shared between functions 0 and 1. The interrupt mode select is programmed through this register. The socket-capable force bits are also programmed through this register. See Table 4–17 for a complete description of the register contents.

| Bit     | 7              | 6  | 5  | 4 | 3  | 2  | 1  | 0  |
|---------|----------------|----|----|---|----|----|----|----|
| Name    | Device control |    |    |   |    |    |    |    |
| Type    | RW             | RW | RW | R | RW | RW | RW | RW |
| Default | 0              | 1  | 1  | 0 | 0  | 1  | 1  | 0  |

Register: **Device control**  
 Offset: 92h (Functions 0, 1)  
 Type: Read-only, Read/Write  
 Default: 66h

**Table 4–17. Device Control Register Description**

| BIT    | SIGNAL      | TYPE | FUNCTION   |
|--------|-------------|------|--|
| 7 ‡    | SKTPWR_LOCK | RW   | Socket power lock bit. When this bit is set to 1, software cannot power down the PC Card socket while in D3. It may be necessary to lock socket power in order to support wake on LAN or RING if the operating system is programmed to power down a socket when the CardBus controller is placed in the D3 state.  |
| 6 ‡§   | 3VCAPABLE   | RW   | 3-V socket capable force bit.<br>0 = Not 3-V capable<br>1 = 3-V capable (default)  |
| 5 ‡    | IO16R2      | RW   | Diagnostic bit. This bit defaults to 1.  |
| 4      | RSVD        | R    | Reserved. This bit returns 0 when read. A write has no effect.   |
| 3 ‡§   | TEST        | RW   | TI test bit. Write only 0 to this bit.   |
| 2–1 ‡§ | INTMODE     | RW   | Interrupt mode. These bits select the interrupt signaling mode. The interrupt mode bits are encoded:<br>00 = Parallel PCI interrupts only<br>01 = Reserved<br>10 = IRQ serialized interrupts and parallel PCI interrupts $\overline{INTA}$ , $\overline{INTB}$ , $\overline{INTC}$ , and $\overline{INTD}$ .<br>11 = IRQ and PCI serialized interrupts (default) |
| 0 ‡§   | RSVD        | RW   | Reserved. Bit 0 is reserved for test purposes. Only a 0 must be written to this bit.   |

‡ One or more bits in this register are cleared only by the assertion of  $\overline{GRST}$ .

§ These bits are global in nature and must be accessed only through function 0.

## 4.40 Diagnostic Register

The diagnostic register is provided for internal TI test purposes. It is a read/write register, but only 0s must be written to it. See Table 4–18 for a complete description of the register contents.

| Bit     | 7          | 6 | 5  | 4  | 3  | 2  | 1  | 0  |
|---------|------------|---|----|----|----|----|----|----|
| Name    | Diagnostic |   |    |    |    |    |    |    |
| Type    | RW         | R | RW | RW | RW | RW | RW | RW |
| Default | 0          | 1 | 1  | 0  | 0  | 0  | 0  | 0  |

Register: **Diagnostic**  
 Offset: 93h (functions 0, 1)  
 Type: Read/Write  
 Default: 60h

**Table 4–18. Diagnostic Register Description**

| BIT  | SIGNAL   | TYPE | FUNCTION  |
|------|----------|------|---|
| 7 ‡§ | TRUE_VAL | RW   | This bit defaults to 0. This bit is encoded as:<br>0 = Reads true values in PCI vendor ID and PCI device ID registers (default)<br>1 = Returns all 1s to reads from the PCI vendor ID and PCI device ID registers                   |
| 6 ‡  | RSVD     | R    | Reserved. This bit is read-only and returns 1 when read.  |
| 5 ‡  | CSC      | RW   | CSC interrupt routing control<br>0 = CSC interrupts routed to PCI if ExCA 803 bit 4 = 1<br>1 = CSC interrupts routed to PCI if ExCA 805 bits 7–4 = 0000b (default).<br>In this case, the setting of ExCA 803 bit 4 is a don't care. |
| 4 ‡§ | DIAG4    | RW   | Diagnostic RETRY_DIS. Delayed transaction disable.  |
| 3 ‡§ | DIAG3    | RW   | Diagnostic RETRY_EXT. Extends the latency from 16 to 64.  |
| 2 ‡§ | DIAG2    | RW   | Diagnostic DISCARD_TIM_SEL_CB. Set = $2^{10}$ , reset = $2^{15}$ .  |
| 1 ‡§ | DIAG1    | RW   | Diagnostic DISCARD_TIM_SEL_PCI. Set = $2^{10}$ , reset = $2^{15}$ .   |
| 0 ‡  | RSVD     | RW   | This bit is reserved. Do not change the value of this bit.  |

‡ One or more bits in this register are cleared only by the assertion of  $\overline{\text{GRST}}$ .

§ This bit is global and is accessed only through function 0.

## 4.41 Capability ID Register

The capability ID register identifies the linked list item as the register for PCI power management. The register returns 01h when read, which is the unique ID assigned by the PCI SIG for the PCI location of the capabilities pointer and the value.

| Bit     | 7             | 6 | 5 | 4 | 3 | 2 | 1 | 0 |
|---------|---------------|---|---|---|---|---|---|---|
| Name    | Capability ID |   |   |   |   |   |   |   |
| Type    | R             | R | R | R | R | R | R | R |
| Default | 0             | 0 | 0 | 0 | 0 | 0 | 0 | 1 |

Register: **Capability ID**  
Offset: A0h  
Type: Read-only  
Default: 01h

## 4.42 Next Item Pointer Register

The contents of this register indicate the next item in the linked list of the PCI power management capabilities. Because the PCI6x20 functions only include one capabilities item, this register returns 0s when read.

| Bit     | 7                 | 6 | 5 | 4 | 3 | 2 | 1 | 0 |
|---------|-------------------|---|---|---|---|---|---|---|
| Name    | Next item pointer |   |   |   |   |   |   |   |
| Type    | R                 | R | R | R | R | R | R | R |
| Default | 0                 | 0 | 0 | 0 | 0 | 0 | 0 | 0 |

Register: **Next item pointer**  
Offset: A1h  
Type: Read-only  
Default: 00h

## 4.43 Power Management Capabilities Register

The power management capabilities register contains information on the capabilities of the PC Card function related to power management. Both PCI6x20 CardBus bridge functions support D0, D1, D2, and D3 power states. Default register value is FE12h for operation in accordance with *PCI Bus Power Management Interface Specification* revision 1.1. See Table 4–19 for a complete description of the register contents.

| Bit     | 15                            | 14 | 13 | 12 | 11 | 10 | 9 | 8 | 7 | 6 | 5 | 4 | 3 | 2 | 1 | 0 |
|---------|-------------------------------|----|----|----|----|----|---|---|---|---|---|---|---|---|---|---|
| Name    | Power management capabilities |    |    |    |    |    |   |   |   |   |   |   |   |   |   |   |
| Type    | RW                            | R  | R  | R  | R  | R  | R | R | R | R | R | R | R | R | R | R |
| Default | 1                             | 1  | 1  | 1  | 1  | 1  | 1 | 0 | 0 | 0 | 0 | 1 | 0 | 0 | 1 | 0 |

Register: **Power management capabilities**

Offset: A2h (Functions 0, 1)

Type: Read-only, Read/Write

Default: FE12h

**Table 4–19. Power Management Capabilities Register Description**

| BIT   | SIGNAL      | TYPE | FUNCTION   |
|-------|-------------|------|--|
| 15 ‡  | PME support | RW   | This 5-bit field indicates the power states from which the PCI6x20 device functions can assert $\overline{\text{PME}}$ . A 0 for any bit indicates that the function cannot assert the $\overline{\text{PME}}$ signal while in that power state. These 5 bits return 11111b when read. Each of these bits is described below:<br>Bit 15 – defaults to a 1 indicating the $\overline{\text{PME}}$ signal can be asserted from the D3 <sub>cold</sub> state. This bit is read/write because wake-up support from D3 <sub>cold</sub> is contingent on the system providing an auxiliary power source to the V <sub>CC</sub> terminals. If the system designer chooses not to provide an auxiliary power source to the V <sub>CC</sub> terminals for D3 <sub>cold</sub> wake-up support, then BIOS must write a 0 to this bit. |
| 14–11 |             | R    | Bit 14 – contains the value 1 to indicate that the $\overline{\text{PME}}$ signal can be asserted from the D3 <sub>hot</sub> state.<br>Bit 13 – contains the value 1 to indicate that the $\overline{\text{PME}}$ signal can be asserted from the D2 state.<br>Bit 12 – contains the value 1 to indicate that the $\overline{\text{PME}}$ signal can be asserted from the D1 state.<br>Bit 11 – contains the value 1 to indicate that the $\overline{\text{PME}}$ signal can be asserted from the D0 state.  |
| 10    |             | R    | This bit returns a 1 when read, indicating that the function supports the D2 device power state.   |
| 9     |             | R    | This bit returns a 1 when read, indicating that the function supports the D1 device power state.   |
| 8–6   |             | R    | Reserved. These bits return 000b when read.  |
| 5     | DSI         | R    | Device-specific initialization. This bit returns 0 when read.  |
| 4     | AUX_PWR     | R    | Auxiliary power source. This bit is meaningful only if bit 15 (D3 <sub>cold</sub> supporting $\overline{\text{PME}}$ ) is set. When this bit is set, it indicates that support for $\overline{\text{PME}}$ in D3 <sub>cold</sub> requires auxiliary power supplied by the system by way of a proprietary delivery vehicle.<br>A 0 (zero) in this bit field indicates that the function supplies its own auxiliary power source.<br>If the function does not support $\overline{\text{PME}}$ while in the D3 <sub>cold</sub> state (bit 15=0), then this field must always return 0.  |
| 3     | PMECLK      | R    | When this bit is 1, it indicates that the function relies on the presence of the PCI clock for $\overline{\text{PME}}$ operation. When this bit is 0, it indicates that no PCI clock is required for the function to generate $\overline{\text{PME}}$ .<br>Functions that do not support $\overline{\text{PME}}$ generation in any state must return 0 for this field.   |
| 2–0   | Version     | R    | These 3 bits return 010b when read, indicating that there are 4 bytes of general-purpose power management (PM) registers as described in draft revision 1.1 of the <i>PCI Bus Power Management Interface Specification</i> .   |

‡ One or more bits in this register are cleared only by the assertion of  $\overline{\text{GRST}}$ .

## 4.44 Power Management Control/Status Register

The power management control/status register determines and changes the current power state of the PCI6x20 CardBus function. The contents of this register are not affected by the internally generated reset caused by the transition from the D3<sub>hot</sub> to D0 state. See Table 4–20 for a complete description of the register contents.

All PCI registers, ExCA registers, and CardBus registers are reset as a result of a D3<sub>hot</sub>-to-D0 state transition, with the exception of the  $\overline{\text{PME}}$  context bits (if  $\overline{\text{PME}}$  is enabled) and the  $\overline{\text{GRST}}$  only bits.

| Bit     | 15                              | 14 | 13 | 12 | 11 | 10 | 9 | 8  | 7 | 6 | 5 | 4 | 3 | 2 | 1  | 0  |
|---------|---------------------------------|----|----|----|----|----|---|----|---|---|---|---|---|---|----|----|
| Name    | Power management control/status |    |    |    |    |    |   |    |   |   |   |   |   |   |    |    |
| Type    | RWC                             | R  | R  | R  | R  | R  | R | RW | R | R | R | R | R | R | RW | RW |
| Default | 0                               | 0  | 0  | 0  | 0  | 0  | 0 | 0  | 0 | 0 | 0 | 0 | 0 | 0 | 0  | 0  |

Register: **Power management control/status**  
 Offset: A4h (Functions 0, 1)  
 Type: Read-only, Read/Write, Read/Write/Clear  
 Default: 0000h

**Table 4–20. Power Management Control/Status Register Description**

| BIT   | SIGNAL     | TYPE | FUNCTION   |
|-------|------------|------|--|
| 15 †  | PMESTAT    | RC   | PME status. This bit is set when the CardBus function would normally assert the $\overline{\text{PME}}$ signal, independent of the state of the $\overline{\text{PME\_EN}}$ bit. This bit is cleared by a writeback of 1, and this also clears the $\overline{\text{PME}}$ signal if $\overline{\text{PME}}$ was asserted by this function. Writing a 0 to this bit has no effect. |
| 14–13 | DATASCALE  | R    | This 2-bit field returns 0s when read. The CardBus function does not return any dynamic data.  |
| 12–9  | DATASEL    | R    | Data select. This 4-bit field returns 0s when read. The CardBus function does not return any dynamic data.   |
| 8 ‡   | PME_ENABLE | RW   | This bit enables the function to assert $\overline{\text{PME}}$ . If this bit is cleared, then assertion of $\overline{\text{PME}}$ is disabled. This bit is not cleared by the assertion of $\overline{\text{PRST}}$ . It is only cleared by the assertion of $\overline{\text{GRST}}$ .  |
| 7–2   | RSVD       | R    | Reserved. These bits return 0s when read.  |
| 1–0   | PWRSTATE   | RW   | Power state. This 2-bit field is used both to determine the current power state of a function and to set the function into a new power state. This field is encoded as:<br>00 = D0<br>01 = D1<br>10 = D2<br>11 = D3 <sub>hot</sub>   |

† One or more bits in this register are PME context bits and can be cleared only by the assertion of  $\overline{\text{GRST}}$  when  $\overline{\text{PME}}$  is enabled. If  $\overline{\text{PME}}$  is not enabled, then this bit is cleared by the assertion of  $\overline{\text{PRST}}$  or  $\overline{\text{GRST}}$ .

‡ One or more bits in this register are cleared only by the assertion of  $\overline{\text{GRST}}$ .

## 4.45 Power Management Control/Status Bridge Support Extensions Register

This register supports PCI bridge-specific functionality. It is required for all PCI-to-PCI bridges. See Table 4–21 for a complete description of the register contents.

| Bit     | 7   | 6 | 5 | 4 | 3 | 2 | 1 | 0 |
|---------|---|---|---|---|---|---|---|---|
| Name    | Power management control/status bridge support extensions |   |   |   |   |   |   |   |
| Type    | R   | R | R | R | R | R | R | R |
| Default | 1   | 1 | 0 | 0 | 0 | 0 | 0 | 0 |

Register: **Power management control/status bridge support extensions**  
 Offset: A6h (Functions 0, 1)  
 Type: Read-only  
 Default: C0h

**Table 4–21. Power Management Control/Status Bridge Support Extensions Register Description**

| BIT | SIGNAL                     | TYPE | FUNCTION   |
|-----|----------------------------|------|--|
| 7   | BPCC_EN                    | R    | Bus power/clock control enable. This bit returns 1 when read. This bit is encoded as:<br>0 = Bus power/clock control is disabled.<br>1 = Bus power/clock control is enabled (default).<br><br>A 0 indicates that the bus power/clock control policies defined in the <i>PCI Bus Power Management Interface Specification</i> are disabled. When the bus power/clock control enable mechanism is disabled, the power state field (bits 1–0) of the power management control/status register (PCI offset A4h, see Section 4.44) cannot be used by the system software to control the power or the clock of the secondary bus. A 1 indicates that the bus power/clock control mechanism is enabled. |
| 6   | $\overline{\text{B2\_B3}}$ | R    | B2/B3 support for D3 <sub>hot</sub> . The state of this bit determines the action that is to occur as a direct result of programming the function to D3 <sub>hot</sub> . This bit is only meaningful if bit 7 (BPCC_EN) is a 1. This bit is encoded as:<br>0 = When the bridge is programmed to D3 <sub>hot</sub> , its secondary bus has its power removed (B3).<br>1 = When the bridge function is programmed to D3 <sub>hot</sub> , its secondary bus PCI clock is stopped (B2) (default).  |
| 5–0 | RSVD                       | R    | Reserved. These bits return 0s when read.  |

## 4.46 Power-Management Data Register

The power-management data register returns 0s when read, because the CardBus functions do not report dynamic data.

| Bit     | 7                     | 6 | 5 | 4 | 3 | 2 | 1 | 0 |
|---------|-----------------------|---|---|---|---|---|---|---|
| Name    | Power-management data |   |   |   |   |   |   |   |
| Type    | R                     | R | R | R | R | R | R | R |
| Default | 0                     | 0 | 0 | 0 | 0 | 0 | 0 | 0 |

Register: **Power-management data**  
 Offset: A7h (functions 0, 1)  
 Type: Read-only  
 Default: 00h

## 4.47 Serial Bus Data Register

The serial bus data register is for programmable serial bus byte reads and writes. This register represents the data when generating cycles on the serial bus interface. To write a byte, this register must be programmed with the data, the serial bus index register must be programmed with the byte address, the serial bus slave address must be programmed with the 7-bit slave address, and the read/write indicator bit must be reset.

On byte reads, the byte address is programmed into the serial bus index register, the serial bus slave address register must be programmed with both the 7-bit slave address and the read/write indicator bit, and bit 5 (REQBUSY) in the serial bus control and status register (see Section 4.50) must be polled until clear. Then the contents of this register are valid read data from the serial bus interface. See Table 4–22 for a complete description of the register contents.

| Bit     | 7               | 6  | 5  | 4  | 3  | 2  | 1  | 0  |
|---------|-----------------|----|----|----|----|----|----|----|
| Name    | Serial bus data |    |    |    |    |    |    |    |
| Type    | RW              | RW | RW | RW | RW | RW | RW | RW |
| Default | 0               | 0  | 0  | 0  | 0  | 0  | 0  | 0  |

Register: **Serial bus data**  
 Offset: B0h (function 0)  
 Type: Read/Write  
 Default: 00h

**Table 4–22. Serial Bus Data Register Description**

| BIT   | SIGNAL | TYPE | FUNCTION  |
|-------|--------|------|---|
| 7–0 ‡ | SBDATA | RW   | Serial bus data. This bit field represents the data byte in a read or write transaction on the serial interface. On reads, the REQBUSY bit must be polled to verify that the contents of this register are valid. |

‡ One or more bits in this register are cleared only by the assertion of  $\overline{\text{GRST}}$ .

## 4.48 Serial Bus Index Register

The serial bus index register is for programmable serial bus byte reads and writes. This register represents the byte address when generating cycles on the serial bus interface. To write a byte, the serial bus data register must be programmed with the data, this register must be programmed with the byte address, and the serial bus slave address must be programmed with both the 7-bit slave address and the read/write indicator.

On byte reads, the word address is programmed into this register, the serial bus slave address must be programmed with both the 7-bit slave address and the read/write indicator bit, and bit 5 (REQBUSY) in the serial bus control and status register (see Section 4.50) must be polled until clear. Then the contents of the serial bus data register are valid read data from the serial bus interface. See Table 4–23 for a complete description of the register contents.

| Bit     | 7                | 6  | 5  | 4  | 3  | 2  | 1  | 0  |
|---------|------------------|----|----|----|----|----|----|----|
| Name    | Serial bus index |    |    |    |    |    |    |    |
| Type    | RW               | RW | RW | RW | RW | RW | RW | RW |
| Default | 0                | 0  | 0  | 0  | 0  | 0  | 0  | 0  |

Register: **Serial bus index**  
 Offset: B1h (function 0)  
 Type: Read/Write  
 Default: 00h

**Table 4–23. Serial Bus Index Register Description**

| BIT   | SIGNAL | TYPE | FUNCTION   |
|-------|--------|------|--|
| 7–0 ‡ | SINDEX | RW   | Serial bus index. This bit field represents the byte address in a read or write transaction on the serial interface. |

‡ One or more bits in this register are cleared only by the assertion of  $\overline{\text{GRST}}$ .

## 4.49 Serial Bus Slave Address Register

The serial bus slave address register is for programmable serial bus byte read and write transactions. To write a byte, the serial bus data register must be programmed with the data, the serial bus index register must be programmed with the byte address, and this register must be programmed with both the 7-bit slave address and the read/write indicator bit.

On byte reads, the byte address is programmed into the serial bus index register, this register must be programmed with both the 7-bit slave address and the read/write indicator bit, and bit 5 (REQBUSY) in the serial bus control and status register (see Section 4.50) must be polled until clear. Then the contents of the serial bus data register are valid read data from the serial bus interface. See Table 4–24 for a complete description of the register contents.

| Bit     | 7                        | 6  | 5  | 4  | 3  | 2  | 1  | 0  |
|---------|--------------------------|----|----|----|----|----|----|----|
| Name    | Serial bus slave address |    |    |    |    |    |    |    |
| Type    | RW                       | RW | RW | RW | RW | RW | RW | RW |
| Default | 0                        | 0  | 0  | 0  | 0  | 0  | 0  | 0  |

Register: **Serial bus slave address**  
 Offset: B2h (function 0)  
 Type: Read/Write  
 Default: 00h

**Table 4–24. Serial Bus Slave Address Register Description**

| BIT   | SIGNAL   | TYPE | FUNCTION   |
|-------|----------|------|--|
| 7–1 ‡ | SLAVADDR | RW   | Serial bus slave address. This bit field represents the slave address of a read or write transaction on the serial interface.  |
| 0 ‡   | RWCMD    | RW   | Read/write command. Bit 0 indicates the read/write command bit presented to the serial bus on byte read and write accesses.<br>0 = A byte write access is requested to the serial bus interface.<br>1 = A byte read access is requested to the serial bus interface. |

‡ One or more bits in this register are cleared only by the assertion of  $\overline{\text{GRST}}$ .

## 4.50 Serial Bus Control/Status Register

The serial bus control and status register communicates serial bus status information and selects the quick command protocol. Bit 5 (REQBUSY) in this register must be polled during serial bus byte reads to indicate when data is valid in the serial bus data register. See Table 4–25 for a complete description of the register contents.

| Bit     | 7                         | 6 | 5 | 4 | 3  | 2  | 1  | 0  |
|---------|---------------------------|---|---|---|----|----|----|----|
| Name    | Serial bus control/status |   |   |   |    |    |    |    |
| Type    | RW                        | R | R | R | RW | RW | RC | RC |
| Default | 0                         | 0 | 0 | 0 | 0  | 0  | 0  | 0  |

Register: **Serial bus control/status**  
 Offset: B3h (function 0)  
 Type: Read-only, Read/Write, Read/Clear  
 Default: 00h

**Table 4–25. Serial Bus Control/Status Register Description**

| BIT | SIGNAL   | TYPE | FUNCTION   |
|-----|----------|------|--|
| 7 ‡ | PROT_SEL | RW   | Protocol select. When bit 7 is set, the send-byte protocol is used on write requests and the receive-byte protocol is used on read commands. The word address byte in the serial bus index register (see Section 4.48) is not output by the PCI6x20 device when bit 7 is set.  |
| 6   | RSVD     | R    | Reserved. Bit 6 returns 0 when read.   |
| 5   | REQBUSY  | R    | Requested serial bus access busy. Bit 5 indicates that a requested serial bus access (byte read or write) is in progress. A request is made, and bit 5 is set, by writing to the serial bus slave address register (see Section 4.49). Bit 5 must be polled on reads from the serial interface. After the byte read access has been completed, this bit is cleared and the read data is valid in the serial bus data register.   |
| 4   | ROMBUSY  | R    | Serial EEPROM busy status. Bit 4 indicates the status of the PCI6x20 serial EEPROM circuitry. Bit 4 is set during the loading of the subsystem ID and other default values from the serial bus EEPROM.<br>0 = Serial EEPROM circuitry is not busy<br>1 = Serial EEPROM circuitry is busy   |
| 3 ‡ | SBDETECT | RW   | Serial bus detect. When the serial bus interface is detected through a pullup resistor on the SCL terminal after reset, this bit is set to 1.<br>0 = Serial bus interface not detected<br>1 = Serial bus interface detected  |
| 2 ‡ | SBTEST   | RW   | Serial bus test. When bit 2 is set, the serial bus clock frequency is increased for test purposes.<br>0 = Serial bus clock at normal operating frequency, ≈ 100 kHz (default)<br>1 = Serial bus clock frequency increased for test purposes  |
| 1 ‡ | REQ_ERR  | RC   | Requested serial bus access error. Bit 1 indicates when a data error occurs on the serial interface during a requested cycle and may be set due to a missing acknowledge. Bit 1 is cleared by a writeback of 1.<br>0 = No error detected during user-requested byte read or write cycle<br>1 = Data error detected during user-requested byte read or write cycle  |
| 0 ‡ | ROM_ERR  | RC   | EEPROM data error status. Bit 0 indicates when a data error occurs on the serial interface during the auto-load from the serial bus EEPROM and may be set due to a missing acknowledge. Bit 0 is also set on invalid EEPROM data formats. See Section 3.7.4, <i>Serial Bus EEPROM Application</i> , for details on EEPROM data format. Bit 0 is cleared by a writeback of 1.<br>0 = No error detected during autoloading from serial bus EEPROM<br>1 = Data error detected during autoloading from serial bus EEPROM |

‡ One or more bits in this register are cleared only by the assertion of  $\overline{GRST}$ .

## 5 ExCA Compatibility Registers (Functions 0 and 1)

The ExCA (exchangeable card architecture) registers implemented in the PCI6x20 device are register-compatible with the Intel 82365SL-DF PCMCIA controller. ExCA registers are identified by an offset value, which is compatible with the legacy I/O index/data scheme used on the Intel™ 82365 ISA controller. The ExCA registers are accessed through this scheme by writing the register offset value into the index register (I/O base), and reading or writing the data register (I/O base + 1). The I/O base address used in the index/data scheme is programmed in the PC Card 16-bit I/F legacy mode base address register, which is shared by both card sockets. The offsets from this base address run contiguously from 00h to 3Fh for socket A, and from 40h to 7Fh for socket B. See Figure 5–1 for an ExCA I/O mapping illustration. Table 5–1 identifies each ExCA register and its respective ExCA offset.

The PCI6x20 device also provides a memory-mapped alias of the ExCA registers by directly mapping them into PCI memory space. They are located through the CardBus socket registers/ExCA registers base address register (PCI register 10h) at memory offset 800h. Each socket has a separate base address programmable by function. See Figure 5–2 for an ExCA memory mapping illustration. Note that memory offsets are 800h–844h for both functions 0 and 1. This illustration also identifies the CardBus socket register mapping, which is mapped into the same 4K window at memory offset 0h.

The interrupt registers in the ExCA register set, as defined by the 82365SL specification, control such card functions as reset, type, interrupt routing, and interrupt enables. Special attention must be paid to the interrupt routing registers and the host interrupt signaling method selected for the PCI6x20 device to ensure that all possible PCI6x20 interrupts can potentially be routed to the programmable interrupt controller. The ExCA registers that are critical to the interrupt signaling are at memory address ExCA offsets 803h and 805h.

Access to I/O mapped 16-bit PC Cards is available to the host system via two ExCA I/O windows. These are regions of host I/O address space into which the card I/O space is mapped. These windows are defined by start, end, and offset addresses programmed in the ExCA registers described in this chapter. I/O windows have byte granularity.

Access to memory-mapped 16-bit PC Cards is available to the host system via five ExCA memory windows. These are regions of host memory space into which the card memory space is mapped. These windows are defined by start, end, and offset addresses programmed in the ExCA registers described in this chapter. Memory windows have 4-Kbyte granularity.

A bit location followed by a ‡ means that this bit is not cleared by the assertion of  $\overline{PRST}$ . This bit is only cleared by the assertion of  $\overline{GRST}$ . This is necessary to retain device context during the transition from D3 to D0.

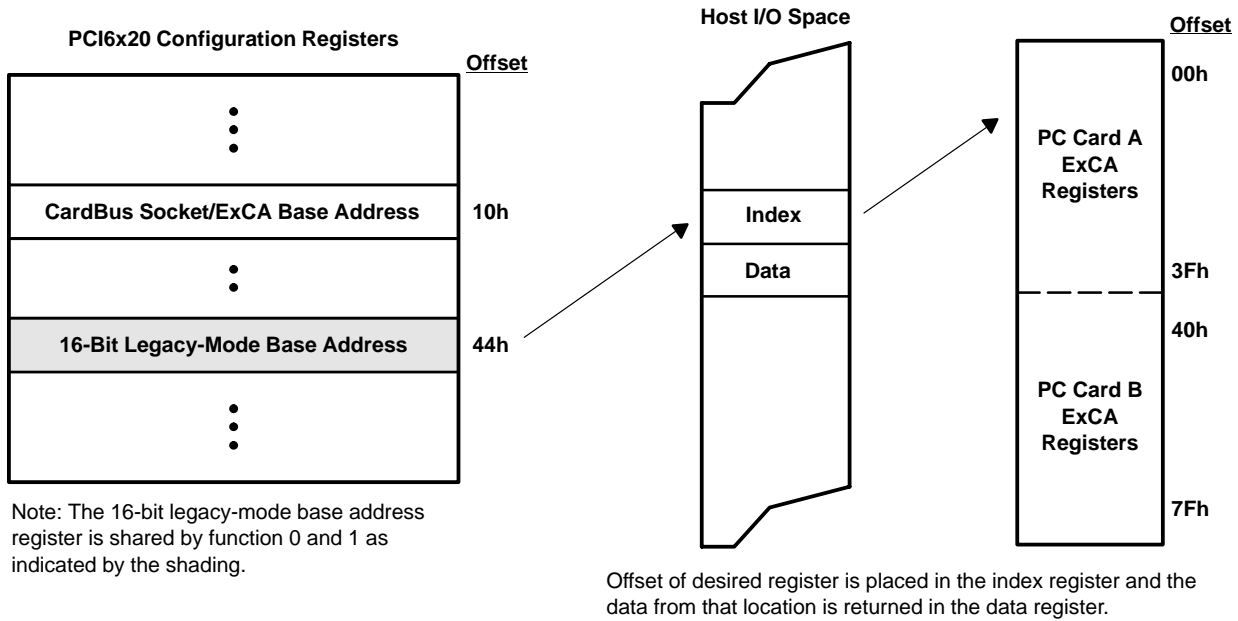

**Figure 5–1. ExCA Register Access Through I/O**

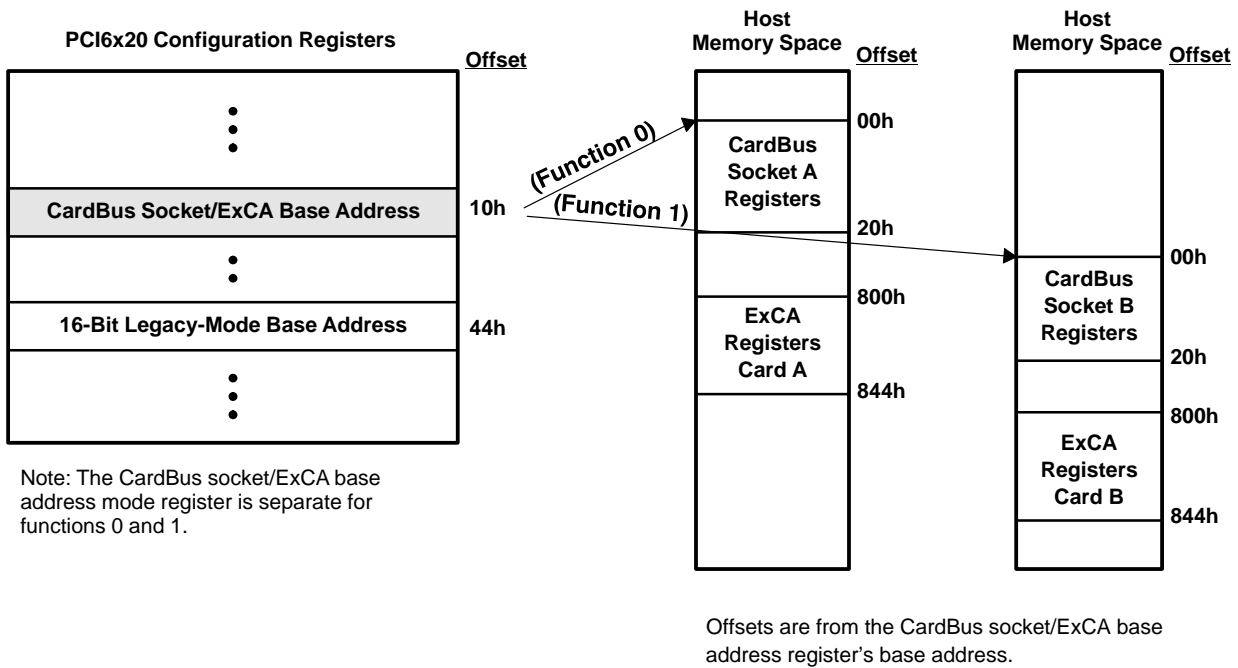

**Figure 5–2. ExCA Register Access Through Memory**

**Table 5–1. ExCA Registers and Offsets**

| EXCA REGISTER NAME                           | PCI MEMORY ADDRESS<br>OFFSET (HEX) | EXCA OFFSET<br>(CARD A) | EXCA OFFSET<br>(CARD B) |
|--|------------------------------------|-------------------------|-------------------------|
| Identification and revision ‡                | 800                                | 00                      | 40                      |
| Interface status                             | 801                                | 01                      | 41                      |
| Power control †                              | 802†                               | 02                      | 42                      |
| Interrupt and general control †              | 803†                               | 03                      | 43                      |
| Card status change †                         | 804†                               | 04                      | 44                      |
| Card status change interrupt configuration † | 805†                               | 05                      | 45                      |
| Address window enable                        | 806                                | 06                      | 46                      |
| I / O window control                         | 807                                | 07                      | 47                      |
| I / O window 0 start-address low-byte        | 808                                | 08                      | 48                      |
| I / O window 0 start-address high-byte       | 809                                | 09                      | 49                      |
| I / O window 0 end-address low-byte          | 80A                                | 0A                      | 4A                      |
| I / O window 0 end-address high-byte         | 80B                                | 0B                      | 4B                      |
| I / O window 1 start-address low-byte        | 80C                                | 0C                      | 4C                      |
| I / O window 1 start-address high-byte       | 80D                                | 0D                      | 4D                      |
| I / O window 1 end-address low-byte          | 80E                                | 0E                      | 4E                      |
| I / O window 1 end-address high-byte         | 80F                                | 0F                      | 4F                      |
| Memory window 0 start-address low-byte       | 810                                | 10                      | 50                      |
| Memory window 0 start-address high-byte      | 811                                | 11                      | 51                      |
| Memory window 0 end-address low-byte         | 812                                | 12                      | 52                      |
| Memory window 0 end-address high-byte        | 813                                | 13                      | 53                      |
| Memory window 0 offset-address low-byte      | 814                                | 14                      | 54                      |
| Memory window 0 offset-address high-byte     | 815                                | 15                      | 55                      |
| Card detect and general control †            | 816                                | 16                      | 56                      |
| Reserved                                     | 817                                | 17                      | 57                      |
| Memory window 1 start-address low-byte       | 818                                | 18                      | 58                      |
| Memory window 1 start-address high-byte      | 819                                | 19                      | 59                      |
| Memory window 1 end-address low-byte         | 81A                                | 1A                      | 5A                      |
| Memory window 1 end-address high-byte        | 81B                                | 1B                      | 5B                      |
| Memory window 1 offset-address low-byte      | 81C                                | 1C                      | 5C                      |
| Memory window 1 offset-address high-byte     | 81D                                | 1D                      | 5D                      |
| Global control ‡                             | 81E                                | 1E                      | 5E                      |
| Reserved                                     | 81F                                | 1F                      | 5F                      |
| Memory window 2 start-address low-byte       | 820                                | 20                      | 60                      |
| Memory window 2 start-address high-byte      | 821                                | 21                      | 61                      |
| Memory window 2 end-address low-byte         | 822                                | 22                      | 62                      |
| Memory window 2 end-address high-byte        | 823                                | 23                      | 63                      |
| Memory window 2 offset-address low-byte      | 824                                | 24                      | 64                      |
| Memory window 2 offset-address high-byte     | 825                                | 25                      | 65                      |

† One or more bits in this register are cleared only by the assertion of  $\overline{GRST}$  when  $\overline{PME}$  is enabled. If  $\overline{PME}$  is not enabled, then this bit is cleared by the assertion of  $\overline{PRST}$  or  $\overline{GRST}$ .

‡ One or more bits in this register are cleared only by the assertion of  $\overline{GRST}$ .

**Table 5–1. ExCA Registers and Offsets (continued)**

| EXCA REGISTER NAME                       | PCI MEMORY ADDRESS<br>OFFSET (HEX) | EXCA OFFSET<br>(CARD A) | EXCA OFFSET<br>(CARD B) |
|--|------------------------------------|-------------------------|-------------------------|
| Reserved                                 | 826                                | 26                      | 66                      |
| Reserved                                 | 827                                | 27                      | 67                      |
| Memory window 3 start-address low-byte   | 828                                | 28                      | 68                      |
| Memory window 3 start-address high-byte  | 829                                | 29                      | 69                      |
| Memory window 3 end-address low-byte     | 82A                                | 2A                      | 6A                      |
| Memory window 3 end-address high-byte    | 82B                                | 2B                      | 6B                      |
| Memory window 3 offset-address low-byte  | 82C                                | 2C                      | 6C                      |
| Memory window 3 offset-address high-byte | 82D                                | 2D                      | 6D                      |
| Reserved                                 | 82E                                | 2E                      | 6E                      |
| Reserved                                 | 82F                                | 2F                      | 6F                      |
| Memory window 4 start-address low-byte   | 830                                | 30                      | 70                      |
| Memory window 4 start-address high-byte  | 831                                | 31                      | 71                      |
| Memory window 4 end-address low-byte     | 832                                | 32                      | 72                      |
| Memory window 4 end-address high-byte    | 833                                | 33                      | 73                      |
| Memory window 4 offset-address low-byte  | 834                                | 34                      | 74                      |
| Memory window 4 offset-address high-byte | 835                                | 35                      | 75                      |
| I/O window 0 offset-address low-byte     | 836                                | 36                      | 76                      |
| I/O window 0 offset-address high-byte    | 837                                | 37                      | 77                      |
| I/O window 1 offset-address low-byte     | 838                                | 38                      | 78                      |
| I/O window 1 offset-address high-byte    | 839                                | 39                      | 79                      |
| Reserved                                 | 83A                                | 3A                      | 7A                      |
| Reserved                                 | 83B                                | 3B                      | 7B                      |
| Reserved                                 | 83C                                | 3C                      | 7C                      |
| Reserved                                 | 83D                                | 3D                      | 7D                      |
| Reserved                                 | 83E                                | 3E                      | 7E                      |
| Reserved                                 | 83F                                | 3F                      | 7F                      |
| Memory window page register 0            | 840                                | –                       | –                       |
| Memory window page register 1            | 841                                | –                       | –                       |
| Memory window page register 2            | 842                                | –                       | –                       |
| Memory window page register 3            | 843                                | –                       | –                       |
| Memory window page register 4            | 844                                | –                       | –                       |

## 5.1 ExCA Identification and Revision Register

This register provides host software with information on 16-bit PC Card support and 82365SL-DF compatibility. See Table 5–2 for a complete description of the register contents.

**NOTE:** If bit 5 (SUBSYRW) in the system control register is 1, then this register is read-only.

| Bit     | 7                                | 6 | 5  | 4  | 3  | 2  | 1  | 0  |
|---------|----------------------------------|---|----|----|----|----|----|----|
| Name    | ExCA identification and revision |   |    |    |    |    |    |    |
| Type    | R                                | R | RW | RW | RW | RW | RW | RW |
| Default | 1                                | 0 | 0  | 0  | 0  | 1  | 0  | 0  |

Register: **ExCA identification and revision**

Offset: CardBus Socket Address + 800h: Card A ExCA Offset 00h  
Card B ExCA Offset 40h

Type: Read/Write, Read-only

Default: 84h

**Table 5–2. ExCA Identification and Revision Register Description**

| BIT   | SIGNAL | TYPE | FUNCTION   |
|-------|--------|------|--|
| 7–6 ‡ | IFTYPE | R    | Interface type. These bits, which are hardwired as 10b, identify the 16-bit PC Card support provided by the PCI6x20 device. The PCI6x20 device supports both I/O and memory 16-bit PC Cards.   |
| 5–4 ‡ | RSVD   | RW   | These bits can be used for 82365SL emulation.  |
| 3–0 ‡ | 365REV | RW   | 82365SL-DF revision. This field stores the Intel 82365SL-DF revision supported by the PCI6x20 device. Host software can read this field to determine compatibility to the 82365SL-DF register set. This field defaults to 0100b upon reset. Writing 0010b to this field places the controller in the 82356SL mode. |

‡ One or more bits in this register are cleared only by the assertion of GRST.

## 5.2 ExCA Interface Status Register

This register provides information on current status of the PC Card interface. An X in the default bit values indicates that the value of the bit after reset depends on the state of the PC Card interface. See Table 5–3 for a complete description of the register contents.

| Bit     | 7                     | 6 | 5 | 4 | 3 | 2 | 1 | 0 |
|---------|-----------------------|---|---|---|---|---|---|---|
| Name    | ExCA interface status |   |   |   |   |   |   |   |
| Type    | R                     | R | R | R | R | R | R | R |
| Default | 0                     | 0 | X | X | X | X | X | X |

Register: **ExCA interface status**  
 Offset: CardBus Socket Address + 801h: Card A ExCA Offset 01h  
           Card B ExCA Offset 41h  
 Type: Read-only  
 Default: 00XX XXXXb

**Table 5–3. ExCA Interface Status Register Description**

| BIT | SIGNAL   | TYPE | FUNCTION  |
|-----|----------|------|---|
| 7   | RSVD     | R    | This bit returns 0 when read. A write has no effect.  |
| 6   | CARDPWR  | R    | CARDPWR. Card power. This bit indicates the current power status of the PC Card socket. This bit reflects how the ExCA power control register has been programmed. The bit is encoded as:<br>0 = $V_{CC}$ and $V_{pp}$ to the socket are turned off (default).<br>1 = $V_{CC}$ and $V_{pp}$ to the socket are turned on.  |
| 5   | READY    | R    | This bit indicates the current status of the READY signal at the PC Card interface.<br>0 = PC Card is not ready for a data transfer.<br>1 = PC Card is ready for a data transfer.   |
| 4   | CARDWP   | R    | Card write protect. This bit indicates the current status of the WP signal at the PC Card interface. This signal reports to the PCI6x20 device whether or not the memory card is write protected. Further, write protection for an entire PCI6x20 16-bit memory window is available by setting the appropriate bit in the ExCA memory window offset-address high-byte register.<br>0 = WP signal is 0. PC Card is R/W.<br>1 = WP signal is 1. PC Card is read-only.   |
| 3   | CDETECT2 | R    | Card detect 2. This bit indicates the status of the CD2 signal at the PC Card interface. Software can use this and CDETECT1 to determine if a PC Card is fully seated in the socket.<br>0 = $\overline{CD2}$ signal is 1. No PC Card inserted.<br>1 = $\overline{CD2}$ signal is 0. PC Card at least partially inserted.  |
| 2   | CDETECT1 | R    | Card detect 1. This bit indicates the status of the CD1 signal at the PC Card interface. Software can use this and CDETECT2 to determine if a PC Card is fully seated in the socket.<br>0 = $\overline{CD1}$ signal is 1. No PC Card inserted.<br>1 = $\overline{CD1}$ signal is 0. PC Card at least partially inserted.  |
| 1–0 | BVDSTAT  | R    | Battery voltage detect. When a 16-bit memory card is inserted, the field indicates the status of the battery voltage detect signals (BVD1, BVD2) at the PC Card interface, where bit 0 reflects the BVD1 status, and bit 1 reflects BVD2.<br>00 = Battery is dead.<br>01 = Battery is dead.<br>10 = Battery is low; warning.<br>11 = Battery is good.<br><br>When a 16-bit I/O card is inserted, this field indicates the status of the $\overline{SPKR}$ (bit 1) signal and the $\overline{STSCHG}$ (bit 0) at the PC Card interface. In this case, the two bits in this field directly reflect the current state of these card outputs. |



## 5.4 ExCA Interrupt and General Control Register

This register controls interrupt routing for I/O interrupts as well as other critical 16-bit PC Card functions. See Table 5–6 for a complete description of the register contents.

| Bit     | 7                                  | 6  | 5  | 4  | 3  | 2  | 1  | 0  |
|---------|------------------------------------|----|----|----|----|----|----|----|
| Name    | ExCA interrupt and general control |    |    |    |    |    |    |    |
| Type    | RW                                 | RW | RW | RW | RW | RW | RW | RW |
| Default | 0                                  | 0  | 0  | 0  | 0  | 0  | 0  | 0  |

Register: **ExCA interrupt and general control**  
 Offset: CardBus Socket Address + 803h: Card A ExCA Offset 03h  
 Card B ExCA Offset 43h  
 Type: Read/Write  
 Default: 00h

**Table 5–6. ExCA Interrupt and General Control Register Description**

| BIT | SIGNAL    | TYPE | FUNCTION  |
|-----|-----------|------|---|
| 7   | RINGEN    | RW   | Card ring indicate enable. Enables the ring indicate function of the BVD1/RI terminals. This bit is encoded as:<br>0 = Ring indicate disabled (default)<br>1 = Ring indicate enabled  |
| 6 † | RESET     | RW   | Card reset. This bit controls the 16-bit PC Card RESET signal, and allows host software to force a card reset. This bit affects 16-bit cards only. This bit is encoded as:<br>0 = RESET signal asserted (default)<br>1 = RESET signal deasserted.   |
| 5 † | CARDTYPE  | RW   | Card type. This bit indicates the PC Card type. This bit is encoded as:<br>0 = Memory PC Card is installed (default)<br>1 = I/O PC Card is installed  |
| 4   | CSCROUTE  | RW   | PCI interrupt – CSC routing enable bit. This bit has meaning only if the CSC interrupt routing control bit (PCI offset 93h, bit 5) is 0. In this case, when this bit is set (high), the card status change interrupts are routed to PCI interrupts. When low, the card status change interrupts are routed using bits 7–4 in the ExCA card status-change interrupt configuration register (ExCA offset 805h, see Section 5.6). This bit is encoded as:<br>0 = CSC interrupts routed by ExCA registers (default)<br>1 = CSC interrupts routed to PCI interrupts<br><br>If the CSC interrupt routing control bit (bit 5) of the diagnostic register (PCI offset 93h, see Section 4.40) is set to 1, this bit has no meaning, which is the default case. |
| 3–0 | INTSELECT | RW   | Card interrupt select for I/O PC Card functional interrupts. These bits select the interrupt routing for I/O PC Card functional interrupts. This field is encoded as:<br>0000 = No IRQ selected (default). CSC interrupts are routed to PCI Interrupts. This bit setting is ORed with bit 4 (CSCROUTE) for backward compatibility.<br>0001 = IRQ1 enabled<br>0010 = SMI enabled<br>0011 = IRQ3 enabled<br>0100 = IRQ4 enabled<br>0101 = IRQ5 enabled<br>0110 = IRQ6 enabled<br>0111 = IRQ7 enabled<br>1000 = IRQ8 enabled<br>1001 = IRQ9 enabled<br>1010 = IRQ10 enabled<br>1011 = IRQ11 enabled<br>1100 = IRQ12 enabled<br>1101 = IRQ13 enabled<br>1110 = IRQ14 enabled<br>1111 = IRQ15 enabled  |

† This bit is cleared only by the assertion of GRST when PME is enabled. If PME is not enabled, then this bit is cleared by the assertion of PRST or GRST.

## 5.5 ExCA Card Status-Change Register

The ExCA card status-change register controls interrupt routing for I/O interrupts, as well as other critical 16-bit PC Card functions. The register enables these interrupt sources to generate an interrupt to the host. When the interrupt source is disabled, the corresponding bit in this register always reads 0. When an interrupt source is enabled, the corresponding bit in this register is set to indicate that the interrupt source is active. After generating the interrupt to the host, the interrupt service routine must read this register to determine the source of the interrupt. The interrupt service routine is responsible for resetting the bits in this register as well. Resetting a bit is accomplished by one of two methods: a read of this register or an explicit writeback of 1 to the status bit. The choice of these two methods is based on bit 2 (interrupt flag clear mode select) in the ExCA global control register (CB offset 81Eh, see Section 5.20). See Table 5–7 for a complete description of the register contents.

| Bit     | 7                       | 6 | 5 | 4 | 3 | 2 | 1 | 0 |
|---------|-------------------------|---|---|---|---|---|---|---|
| Name    | ExCA card status-change |   |   |   |   |   |   |   |
| Type    | R                       | R | R | R | R | R | R | R |
| Default | 0                       | 0 | 0 | 0 | 0 | 0 | 0 | 0 |

Register: **ExCA card status-change**  
 Type: Read-only  
 Offset: CardBus socket address + 804h; Card A ExCA offset 04h  
           Card B ExCA offset 44h  
 Default: 00h

**Table 5–7. ExCA Card Status-Change Register Description**

| BIT | SIGNAL      | TYPE | FUNCTION  |
|-----|-------------|------|---|
| 7–4 | RSVD        | R    | Reserved. Bits 7–4 return 0s when read.   |
| 3 † | CDCHANGE    | R    | Card detect change. Bit 3 indicates whether a change on $\overline{CD1}$ or $\overline{CD2}$ occurred at the PC Card interface. This bit is encoded as:<br>0 = No change detected on either $\overline{CD1}$ or $\overline{CD2}$<br>1 = Change detected on either $\overline{CD1}$ or $\overline{CD2}$  |
| 2 † | READYCHANGE | R    | Ready change. When a 16-bit memory is installed in the socket, bit 2 includes whether the source of a PCI6x20 interrupt was due to a change on READY at the PC Card interface, indicating that the PC Card is now ready to accept new data. This bit is encoded as:<br>0 = No low-to-high transition detected on READY (default)<br>1 = Detected low-to-high transition on READY<br>When a 16-bit I/O card is installed, bit 2 is always 0. |
| 1 † | BATWARN     | R    | Battery warning change. When a 16-bit memory card is installed in the socket, bit 1 indicates whether the source of a PCI6x20 interrupt was due to a battery-low warning condition. This bit is encoded as:<br>0 = No battery warning condition (default)<br>1 = Detected battery warning condition<br>When a 16-bit I/O card is installed, bit 1 is always 0.  |
| 0 † | BATDEAD     | R    | Battery dead or status change. When a 16-bit memory card is installed in the socket, bit 0 indicates whether the source of a PCI6x20 interrupt was due to a battery dead condition. This bit is encoded as:<br>0 = $\overline{STSCHG}$ deasserted (default)<br>1 = $\overline{STSCHG}$ asserted<br>Ring indicate. When the PCI6x20 is configured for ring indicate operation, bit 0 indicates the status of $\overline{RI}$ .               |

† These are PME context bits and can be cleared only by the assertion of  $\overline{GRST}$  when  $\overline{PME}$  is enabled. If  $\overline{PME}$  is not enabled, then these bits are cleared by the assertion of  $\overline{PRST}$  or  $\overline{GRST}$ .

## 5.6 ExCA Card Status-Change Interrupt Configuration Register

This register controls interrupt routing for CSC interrupts, as well as masks/unmasks CSC interrupt sources. See Table 5–8 for a complete description of the register contents.

| Bit     | 7   | 6  | 5  | 4  | 3  | 2  | 1  | 0  |
|---------|---|----|----|----|----|----|----|----|
| Name    | ExCA card status-change interrupt configuration |    |    |    |    |    |    |    |
| Type    | RW  | RW | RW | RW | RW | RW | RW | RW |
| Default | 0   | 0  | 0  | 0  | 0  | 0  | 0  | 0  |

Register: **ExCA card status-change interrupt configuration**  
 Offset: CardBus Socket Address + 805h: Card A ExCA Offset 05h  
           Card B ExCA Offset 45h  
 Type: Read/Write  
 Default: 00h

**Table 5–8. ExCA Card Status-Change Interrupt Configuration Register Description**

| BIT | SIGNAL    | TYPE | FUNCTION   |
|-----|-----------|------|--|
| 7–4 | CSCSELECT | RW   | Interrupt select for card status change. These bits select the interrupt routing for card status-change interrupts. This field is encoded as:<br>0000 = CSC interrupts routed to PCI interrupts if bit 5 of the diagnostic register (PCI offset 93h) is set to 1b. In this case bit 4 of ExCA 803 is a don't care. This is the default setting.<br>0000 = No ISA interrupt routing if bit 5 of the diagnostic register (PCI offset 93h) is set to 0b. In this case, CSC interrupts are routed to PCI interrupts by setting bit 4 of ExCA 803h to 1b.<br>0001 = IRQ1 enabled<br>0010 = SMI enabled<br>0011 = IRQ3 enabled<br>0100 = IRQ4 enabled<br>0101 = IRQ5 enabled<br>0110 = IRQ6 enabled<br>0111 = IRQ7 enabled<br>1000 = IRQ8 enabled<br>1001 = IRQ9 enabled<br>1010 = IRQ10 enabled<br>1011 = IRQ11 enabled<br>1100 = IRQ12 enabled<br>1101 = IRQ13 enabled<br>1110 = IRQ14 enabled<br>1111 = IRQ15 enabled |
| 3†  | CDEN      | RW   | Card detect enable. Enables interrupts on CD1 or CD2 changes. This bit is encoded as:<br>0 = Disables interrupts on CD1 or CD2 line changes (default)<br>1 = Enables interrupts on CD1 or CD2 line changes   |
| 2†  | READYEN   | RW   | Ready enable. This bit enables/disables a low-to-high transition on the PC Card READY signal to generate a host interrupt. This interrupt source is considered a card status change. This bit is encoded as:<br>0 = Disables host interrupt generation (default)<br>1 = Enables host interrupt generation  |
| 1†  | BATWARNEN | RW   | Battery warning enable. This bit enables/disables a battery warning condition to generate a CSC interrupt. This bit is encoded as:<br>0 = Disables host interrupt generation (default)<br>1 = Enables host interrupt generation  |
| 0†  | BATDEADEN | RW   | Battery dead enable. This bit enables/disables a battery dead condition on a memory PC Card or assertion of the STSCHG I/O PC Card signal to generate a CSC interrupt.<br>0 = Disables host interrupt generation (default)<br>1 = Enables host interrupt generation  |

† This bit is cleared only by the assertion of  $\overline{GRST}$  when  $\overline{PME}$  is enabled. If  $\overline{PME}$  is not enabled, then this bit is cleared by the assertion of  $\overline{PRST}$  or  $\overline{GRST}$ .

## 5.7 ExCA Address Window Enable Register

The ExCA address window enable register enables/disables the memory and I/O windows to the 16-bit PC Card. By default, all windows to the card are disabled. The PCI6x20 device does not acknowledge PCI memory or I/O cycles to the card if the corresponding enable bit in this register is 0, regardless of the programming of the memory or I/O window start/end/offset address registers. See Table 5–9 for a complete description of the register contents.

| Bit     | 7                          | 6  | 5 | 4  | 3  | 2  | 1  | 0  |
|---------|----------------------------|----|---|----|----|----|----|----|
| Name    | ExCA address window enable |    |   |    |    |    |    |    |
| Type    | RW                         | RW | R | RW | RW | RW | RW | RW |
| Default | 0                          | 0  | 0 | 0  | 0  | 0  | 0  | 0  |

Register: **ExCA address window enable**  
 Type: Read-only, Read/Write  
 Offset: CardBus socket address + 806h; Card A ExCA offset 06h  
           Card B ExCA offset 46h  
 Default: 00h

**Table 5–9. ExCA Address Window Enable Register Description**

| BIT | SIGNAL    | TYPE | FUNCTION   |
|-----|-----------|------|--|
| 7   | IOWIN1EN  | RW   | I/O window 1 enable. Bit 7 enables/disables I/O window 1 for the PC Card. This bit is encoded as:<br>0 = I/O window 1 disabled (default)<br>1 = I/O window 1 enabled             |
| 6   | IOWIN0EN  | RW   | I/O window 0 enable. Bit 6 enables/disables I/O window 0 for the PC Card. This bit is encoded as:<br>0 = I/O window 0 disabled (default)<br>1 = I/O window 0 enabled             |
| 5   | RSVD      | R    | Reserved. Bit 5 returns 0 when read.   |
| 4   | MEMWIN4EN | RW   | Memory window 4 enable. Bit 4 enables/disables memory window 4 for the PC Card. This bit is encoded as:<br>0 = Memory window 4 disabled (default)<br>1 = Memory window 4 enabled |
| 3   | MEMWIN3EN | RW   | Memory window 3 enable. Bit 3 enables/disables memory window 3 for the PC Card. This bit is encoded as:<br>0 = Memory window 3 disabled (default)<br>1 = Memory window 3 enabled |
| 2   | MEMWIN2EN | RW   | Memory window 2 enable. Bit 2 enables/disables memory window 2 for the PC Card. This bit is encoded as:<br>0 = Memory window 2 disabled (default)<br>1 = Memory window 2 enabled |
| 1   | MEMWIN1EN | RW   | Memory window 1 enable. Bit 1 enables/disables memory window 1 for the PC Card. This bit is encoded as:<br>0 = Memory window 1 disabled (default)<br>1 = Memory window 1 enabled |
| 0   | MEMWIN0EN | RW   | Memory window 0 enable. Bit 0 enables/disables memory window 0 for the PC Card. This bit is encoded as:<br>0 = Memory window 0 disabled (default)<br>1 = Memory window 0 enabled |

## 5.8 ExCA I/O Window Control Register

The ExCA I/O window control register contains parameters related to I/O window sizing and cycle timing. See Table 5–10 for a complete description of the register contents.

| Bit     | 7                       | 6  | 5  | 4  | 3  | 2  | 1  | 0  |
|---------|-------------------------|----|----|----|----|----|----|----|
| Name    | ExCA I/O window control |    |    |    |    |    |    |    |
| Type    | RW                      | RW | RW | RW | RW | RW | RW | RW |
| Default | 0                       | 0  | 0  | 0  | 0  | 0  | 0  | 0  |

Register: **ExCA I/O window control**  
 Type: Read/Write  
 Offset: CardBus socket address + 807h: Card A ExCA offset 07h  
           Card B ExCA offset 47h  
 Default: 00h

**Table 5–10. ExCA I/O Window Control Register Description**

| BIT | SIGNAL     | TYPE | FUNCTION   |
|-----|------------|------|--|
| 7   | WAITSTATE1 | RW   | I/O window 1 wait state. Bit 7 controls the I/O window 1 wait state for 16-bit I/O accesses. Bit 7 has no effect on 8-bit accesses. This wait-state timing emulates the ISA wait state used by the Intel 82365SL-DF. This bit is encoded as:<br>0 = 16-bit cycles have standard length (default).<br>1 = 16-bit cycles are extended by one equivalent ISA wait state.                          |
| 6   | ZEROWS1    | RW   | I/O window 1 zero wait state. Bit 6 controls the I/O window 1 wait state for 8-bit I/O accesses. Bit 6 has no effect on 16-bit accesses. This wait-state timing emulates the ISA wait state used by the Intel 82365SL-DF. This bit is encoded as:<br>0 = 8-bit cycles have standard length (default).<br>1 = 8-bit cycles are reduced to equivalent of three ISA cycles.                       |
| 5   | IOSIS16W1  | RW   | I/O window 1 $\overline{\text{IOIS16}}$ source. Bit 5 controls the I/O window 1 automatic data-sizing feature that uses $\overline{\text{IOIS16}}$ from the PC Card to determine the data width of the I/O data transfer. This bit is encoded as:<br>0 = Window data width determined by DATASIZE1, bit 4 (default).<br>1 = Window data width determined by $\overline{\text{IOIS16}}$ .       |
| 4   | DATASIZE1  | RW   | I/O window 1 data size. Bit 4 controls the I/O window 1 data size. Bit 4 is ignored if bit 5 (IOSIS16W1) is set. This bit is encoded as:<br>0 = Window data width is 8 bits (default).<br>1 = Window data width is 16 bits.  |
| 3   | WAITSTATE0 | RW   | I/O window 0 wait state. Bit 3 controls the I/O window 0 wait state for 16-bit I/O accesses. Bit 3 has no effect on 8-bit accesses. This wait-state timing emulates the ISA wait state used by the Intel 82365SL-DF. This bit is encoded as:<br>0 = 16-bit cycles have standard length (default).<br>1 = 16-bit cycles are extended by one equivalent ISA wait state.                          |
| 2   | ZEROWS0    | RW   | I/O window 0 zero wait state. Bit 2 controls the I/O window 0 wait state for 8-bit I/O accesses. Bit 2 has no effect on 16-bit accesses. This wait-state timing emulates the ISA wait state used by the Intel 82365SL-DF. This bit is encoded as:<br>0 = 8-bit cycles have standard length (default).<br>1 = 8-bit cycles are reduced to equivalent of three ISA cycles.                       |
| 1   | IOSIS16W0  | RW   | I/O window 0 $\overline{\text{IOIS16}}$ source. Bit 1 controls the I/O window 0 automatic data sizing feature that uses $\overline{\text{IOIS16}}$ from the PC Card to determine the data width of the I/O data transfer. This bit is encoded as:<br>0 = Window data width is determined by DATASIZE0, bit 0 (default).<br>1 = Window data width is determined by $\overline{\text{IOIS16}}$ . |
| 0   | DATASIZE0  | RW   | I/O window 0 data size. Bit 0 controls the I/O window 0 data size. Bit 0 is ignored if bit 1 (IOSIS16W0) is set. This bit is encoded as:<br>0 = Window data width is 8 bits (default).<br>1 = Window data width is 16 bits.  |



## 5.11 ExCA I/O Windows 0 and 1 End-Address Low-Byte Registers

These registers contain the low byte of the 16-bit I/O window end address for I/O windows 0 and 1. The 8 bits of these registers correspond to the lower 8 bits of the start address.

| Bit            | 7   | 6  | 5  | 4  | 3  | 2  | 1  | 0  |
|----------------|---|----|----|----|----|----|----|----|
| <b>Name</b>    | ExCA I/O windows 0 and 1 end-address low-byte |    |    |    |    |    |    |    |
| <b>Type</b>    | RW  | RW | RW | RW | RW | RW | RW | RW |
| <b>Default</b> | 0   | 0  | 0  | 0  | 0  | 0  | 0  | 0  |

Register: **ExCA I/O window 0 end-address low-byte**

Offset: CardBus Socket Address + 80Ah: Card A ExCA Offset 0Ah  
Card B ExCA Offset 4Ah

Register: **ExCA I/O window 1 end-address low-byte**

Offset: CardBus Socket Address + 80Eh: Card A ExCA Offset 0Eh  
Card B ExCA Offset 4Eh

Type: Read/Write

Default: 00h

## 5.12 ExCA I/O Windows 0 and 1 End-Address High-Byte Registers

These registers contain the high byte of the 16-bit I/O window end address for I/O windows 0 and 1. The 8 bits of these registers correspond to the upper 8 bits of the end address.

| Bit            | 7  | 6  | 5  | 4  | 3  | 2  | 1  | 0  |
|----------------|--|----|----|----|----|----|----|----|
| <b>Name</b>    | ExCA I/O windows 0 and 1 end-address high-byte |    |    |    |    |    |    |    |
| <b>Type</b>    | RW   | RW | RW | RW | RW | RW | RW | RW |
| <b>Default</b> | 0  | 0  | 0  | 0  | 0  | 0  | 0  | 0  |

Register: **ExCA I/O window 0 end-address high-byte**

Offset: CardBus Socket Address + 80Bh: Card A ExCA Offset 0Bh  
Card B ExCA Offset 4Bh

Register: **ExCA I/O window 1 end-address high-byte**

Offset: CardBus Socket Address + 80Fh: Card A ExCA Offset 0Fh  
Card B ExCA Offset 4Fh

Type: Read/Write

Default: 00h













## 5.19 ExCA Card Detect and General Control Register

This register controls how the ExCA registers for the socket respond to card removal. It also reports the status of the  $\overline{VS1}$  and  $\overline{VS2}$  signals at the PC Card interface. Table 5–14 describes each bit in the ExCA card detect and general control register.

| Bit     | 7                                    | 6 | 5 | 4  | 3 | 2 | 1  | 0 |
|---------|--------------------------------------|---|---|----|---|---|----|---|
| Name    | ExCA card detect and general control |   |   |    |   |   |    |   |
| Type    | R                                    | R | W | RW | R | R | RW | R |
| Default | X                                    | X | 0 | 0  | 0 | 0 | 0  | 0 |

Register: **ExCA card detect and general control**  
 Offset: CardBus Socket Address + 816h: Card A ExCA Offset 16h  
 Card B ExCA Offset 56h  
 Type: Read-only, Write-only, Read/Write  
 Default: XX00 0000b

**Table 5–14. ExCA Card Detect and General Control Register Description**

| BIT | SIGNAL    | TYPE | FUNCTION   |
|-----|-----------|------|--|
| 7 † | VS2STAT   | R    | $\overline{VS2}$ . This bit reports the current state of the $\overline{VS2}$ signal at the PC Card interface, and, therefore, does not have a default value.<br>0 = $\overline{VS2}$ is low.<br>1 = $\overline{VS2}$ is high.   |
| 6 † | VS1STAT   | R    | $\overline{VS1}$ . This bit reports the current state of the $\overline{VS1}$ signal at the PC Card interface, and, therefore, does not have a default value.<br>0 = $\overline{VS1}$ is low.<br>1 = $\overline{VS1}$ is high.   |
| 5   | SWCSC     | W    | Software card detect interrupt. If card detect enable, bit 3 in the ExCA card status change interrupt configuration register (ExCA offset 805h, see Section 5.6) is set, then writing a 1 to this bit causes a card-detect card-status-change interrupt for the associated card socket.<br>If the card-detect enable bit is cleared to 0 in the ExCA card status-change interrupt configuration register (ExCA offset 805h, see Section 5.6), then writing a 1 to the software card-detect interrupt bit has no effect. This bit is write-only.<br>A read operation of this bit always returns 0. Writing a 1 to this bit also clears it. If bit 2 of the ExCA global control register (ExCA offset 81Eh, see Section 5.20) is set and a 1 is written to clear bit 3 of the ExCA card status change interrupt register, then this bit also is cleared. |
| 4   | CDRESUME  | RW   | Card detect resume enable. If this bit is set to 1 and a card detect change has been detected on the $\overline{CD1}$ and $\overline{CD2}$ inputs, then the $\overline{RI\_OUT}$ output goes from high to low. The $\overline{RI\_OUT}$ remains low until the card status change bit in the ExCA card status-change register (ExCA offset 804h, see Section 5.5) is cleared. If this bit is a 0, then the card detect resume functionality is disabled.<br>0 = Card detect resume disabled (default)<br>1 = Card detect resume enabled   |
| 3–2 | RSVD      | R    | These bits return 0s when read. Writes have no effect.   |
| 1   | REGCONFIG | RW   | Register configuration upon card removal. This bit controls how the ExCA registers for the socket react to a card removal event. This bit is encoded as:<br>0 = No change to ExCA registers upon card removal (default)<br>1 = Reset ExCA registers upon card removal  |
| 0   | RSVD      | R    | This bit returns 0 when read. A write has no effect.   |

† One or more bits in this register are cleared only by the assertion of  $\overline{GRST}$  when  $\overline{PME}$  is enabled. If  $\overline{PME}$  is not enabled, then this bit is cleared by the assertion of  $\overline{PRST}$  or  $\overline{GRST}$ .

## 5.20 ExCA Global Control Register

This register controls both PC Card sockets, and is not duplicated for each socket. The host interrupt mode bits in this register are retained for 82365SL-DF compatibility. See Table 5–15 for a complete description of the register contents.

| Bit     | 7                   | 6 | 5 | 4  | 3  | 2  | 1  | 0  |
|---------|---------------------|---|---|----|----|----|----|----|
| Name    | ExCA global control |   |   |    |    |    |    |    |
| Type    | R                   | R | R | RW | RW | RW | RW | RW |
| Default | 0                   | 0 | 0 | 0  | 0  | 0  | 0  | 0  |

Register: **ExCA global control**  
 Offset: CardBus Socket Address + 81Eh:      Card A ExCA Offset 1Eh  
    Card B ExCA Offset 5Eh  
 Type: Read-only, Read/Write  
 Default: 00h

**Table 5–15. ExCA Global Control Register Description**

| BIT | SIGNAL   | TYPE | FUNCTION   |
|-----|----------|------|--|
| 7–5 | RSVD     | R    | These bits return 0s when read. Writes have no effect.   |
| 4   | INTMODEB | RW   | Level/edge interrupt mode select, card B. This bit selects the signaling mode for the PCI6x20 host interrupt for card B interrupts. This bit is encoded as:<br>0 = Host interrupt is edge mode (default).<br>1 = Host interrupt is level mode.   |
| 3   | INTMODEA | RW   | Level/edge interrupt mode select, card A. This bit selects the signaling mode for the PCI6x20 host interrupt for card A interrupts. This bit is encoded as:<br>0 = Host interrupt is edge-mode (default).<br>1 = Host interrupt is level-mode.   |
| 2 ‡ | IFCMODE  | RW   | Interrupt flag clear mode select. This bit selects the interrupt flag clear mechanism for the flags in the ExCA card status change register. This bit is encoded as:<br>0 = Interrupt flags cleared by read of CSC register (default)<br>1 = Interrupt flags cleared by explicit writeback of 1  |
| 1 ‡ | CSCMODE  | RW   | Card status change level/edge mode select. This bit selects the signaling mode for the PCI6x20 host interrupt for card status changes. This bit is encoded as:<br>0 = Host interrupt is edge-mode (default).<br>1 = Host interrupt is level-mode.  |
| 0 ‡ | PWRDWN   | RW   | Power-down mode select. When this bit is set to 1, the PCI6x20 device is in power-down mode. In power-down mode the PCI6x20 card outputs are placed in a high-impedance state until an active cycle is executed on the card interface. Following an active cycle the outputs are again placed in a high-impedance state. The PCI6x20 device still receives functional interrupts and/or card status change interrupts; however, an actual card access is required to wake up the interface. This bit is encoded as:<br>0 = Power-down mode disabled (default)<br>1 = Power-down mode enabled |

‡ One or more bits in this register are cleared only by the assertion of  $\overline{GRST}$ .



### 5.23 ExCA Memory Windows 0–4 Page Registers

The upper 8 bits of a 4-byte PCI memory address are compared to the contents of this register when decoding addresses for 16-bit memory windows. Each window has its own page register, all of which default to 00h. By programming this register to a nonzero value, host software can locate 16-bit memory windows in any one of 256 16-Mbyte regions in the 4-gigabyte PCI address space. These registers are only accessible when the ExCA registers are memory-mapped; that is, these registers may not be accessed using the index/data I/O scheme.

| Bit     | 7                            | 6  | 5  | 4  | 3  | 2  | 1  | 0 |
|---------|------------------------------|----|----|----|----|----|----|---|
| Name    | ExCA memory windows 0–4 page |    |    |    |    |    |    |   |
| Type    | RW                           | RW | RW | RW | RW | RW | RW | R |
| Default | 0                            | 0  | 0  | 0  | 0  | 0  | 0  | 0 |

Register: **ExCA memory windows 0–4 page**  
 Offset: CardBus Socket Address + 840h, 841h, 842h, 843h, 844h  
 Type: Read/Write  
 Default: 00h

## 6 CardBus Socket Registers (Functions 0 and 1)

The 1997 PC Card Standard requires a CardBus socket controller to provide five 32-bit registers that report and control socket-specific functions. The PCI6x20 device provides the CardBus socket/ExCA base address register (PCI offset 10h, see Section 4.12) to locate these CardBus socket registers in PCI memory address space. Each function has a separate base address register for accessing the CardBus socket registers (see Figure 6–1). Table 6–1 gives the location of the socket registers in relation to the CardBus socket/ExCA base address.

In addition to the five required registers, the PCI6x20 device implements a register at offset 20h that provides power management control for the socket.

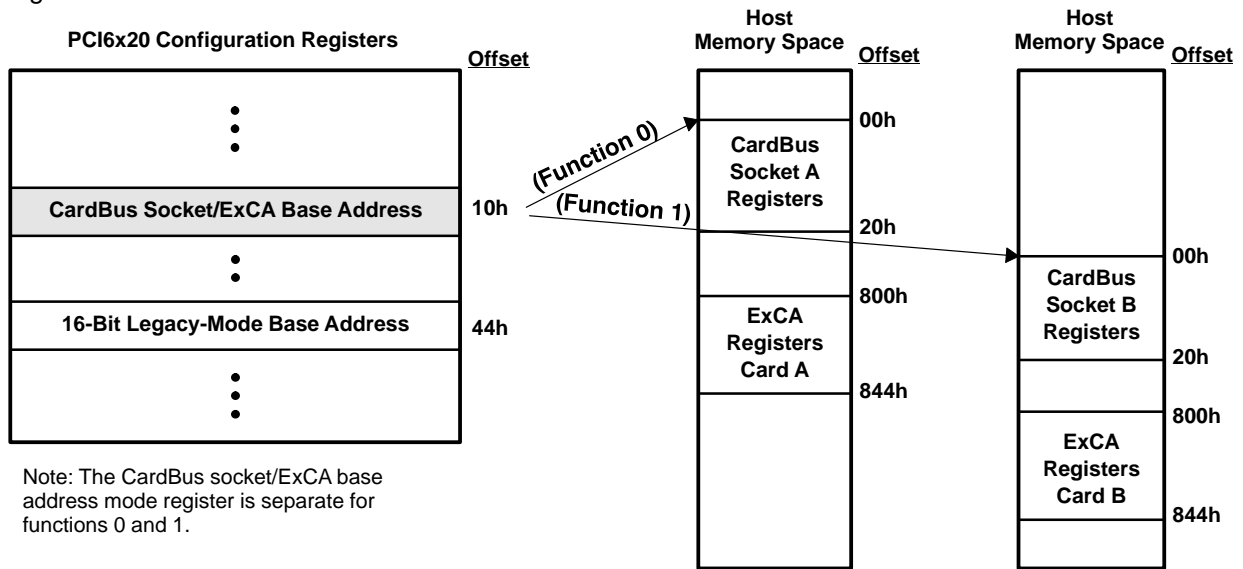

Offsets are from the CardBus socket/ExCA base address register's base address.

Figure 6–1. Accessing CardBus Socket Registers Through PCI Memory

Table 6–1. CardBus Socket Registers

| REGISTER NAME             | OFFSET  |
|---------------------------|---------|
| Socket event †            | 00h     |
| Socket mask †             | 04h     |
| Socket present state †    | 08h     |
| Socket force event        | 0Ch     |
| Socket control †          | 10h     |
| Reserved                  | 14h–1Ch |
| Socket power management ‡ | 20h     |

† One or more bits in the register are PME context bits and can be cleared only by the assertion of  $\overline{\text{GRST}}$  when  $\overline{\text{PME}}$  is enabled. If  $\overline{\text{PME}}$  is not enabled, then these bits are cleared by the assertion of  $\overline{\text{PRST}}$  or  $\overline{\text{GRST}}$ .

‡ One or more bits in this register are cleared only by the assertion of  $\overline{\text{GRST}}$ .

## 6.1 Socket Event Register

This register indicates a change in socket status has occurred. These bits do not indicate what the change is, only that one has occurred. Software must read the socket present state register for current status. Each bit in this register can be cleared by writing a 1 to that bit. The bits in this register can be set to a 1 by software through writing a 1 to the corresponding bit in the socket force event register. All bits in this register are cleared by PCI reset. They can be immediately set again, if, when coming out of PC Card reset, the bridge finds the status unchanged (i.e., CSTSCHG reasserted or card detect is still true). Software needs to clear this register before enabling interrupts. If it is not cleared and interrupts are enabled, then an unmasked interrupt is generated based on any bit that is set. See Table 6–2 for a complete description of the register contents.

| Bit     | 31           | 30 | 29 | 28 | 27 | 26 | 25 | 24 | 23 | 22 | 21 | 20 | 19  | 18  | 17  | 16  |
|---------|--------------|----|----|----|----|----|----|----|----|----|----|----|-----|-----|-----|-----|
| Name    | Socket event |    |    |    |    |    |    |    |    |    |    |    |     |     |     |     |
| Type    | R            | R  | R  | R  | R  | R  | R  | R  | R  | R  | R  | R  | R   | R   | R   | R   |
| Default | 0            | 0  | 0  | 0  | 0  | 0  | 0  | 0  | 0  | 0  | 0  | 0  | 0   | 0   | 0   | 0   |
| Bit     | 15           | 14 | 13 | 12 | 11 | 10 | 9  | 8  | 7  | 6  | 5  | 4  | 3   | 2   | 1   | 0   |
| Name    | Socket event |    |    |    |    |    |    |    |    |    |    |    |     |     |     |     |
| Type    | R            | R  | R  | R  | R  | R  | R  | R  | R  | R  | R  | R  | RWC | RWC | RWC | RWC |
| Default | 0            | 0  | 0  | 0  | 0  | 0  | 0  | 0  | 0  | 0  | 0  | 0  | 0   | 0   | 0   | 0   |

Register: **Socket event**  
 Offset: CardBus Socket Address + 00h  
 Type: Read-only, Read/Write to Clear  
 Default: 0000 0000h

**Table 6–2. Socket Event Register Description**

| BIT  | SIGNAL    | TYPE | FUNCTION   |
|------|-----------|------|--|
| 31–4 | RSVD      | R    | These bits return 0s when read.  |
| 3†   | PWREVENT  | RWC  | Power cycle. This bit is set when the PCI6x20 device detects that the PWRCYCLE bit in the socket present state register (offset 08h, see Section 6.3) has changed. This bit is cleared by writing a 1.   |
| 2†   | CD2EVENT  | RWC  | CCD2. This bit is set when the PCI6x20 device detects that the CDETECT2 field in the socket present state register (offset 08h, see Section 6.3) has changed. This bit is cleared by writing a 1.  |
| 1†   | CD1EVENT  | RWC  | CCD1. This bit is set when the PCI6x20 device detects that the CDETECT1 field in the socket present state register (offset 08h, see Section 6.3) has changed. This bit is cleared by writing a 1.  |
| 0†   | CSTSEVENT | RWC  | CSTSCHG. This bit is set when the CARDSTS field in the socket present state register (offset 08h, see Section 6.3) has changed state. For CardBus cards, this bit is set on the rising edge of the CSTSCHG signal. For 16-bit PC Cards, this bit is set on both transitions of the CSTSCHG signal. This bit is reset by writing a 1. |

† This bit is cleared only by the assertion of GRST when PME is enabled. If PME is not enabled, then this bit is cleared by the assertion of PRST or GRST.

## 6.2 Socket Mask Register

This register allows software to control the CardBus card events which generate a status change interrupt. The state of these mask bits does not prevent the corresponding bits from reacting in the socket event register (offset 00h, see Section 6.1). See Table 6–3 for a complete description of the register contents.

|                |             |    |    |    |    |    |    |    |    |    |    |    |    |    |    |    |
|----------------|-------------|----|----|----|----|----|----|----|----|----|----|----|----|----|----|----|
| <b>Bit</b>     | 31          | 30 | 29 | 28 | 27 | 26 | 25 | 24 | 23 | 22 | 21 | 20 | 19 | 18 | 17 | 16 |
| <b>Name</b>    | Socket mask |    |    |    |    |    |    |    |    |    |    |    |    |    |    |    |
| <b>Type</b>    | R           | R  | R  | R  | R  | R  | R  | R  | R  | R  | R  | R  | R  | R  | R  | R  |
| <b>Default</b> | 0           | 0  | 0  | 0  | 0  | 0  | 0  | 0  | 0  | 0  | 0  | 0  | 0  | 0  | 0  | 0  |
| <b>Bit</b>     | 15          | 14 | 13 | 12 | 11 | 10 | 9  | 8  | 7  | 6  | 5  | 4  | 3  | 2  | 1  | 0  |
| <b>Name</b>    | Socket mask |    |    |    |    |    |    |    |    |    |    |    |    |    |    |    |
| <b>Type</b>    | R           | R  | R  | R  | R  | R  | R  | R  | R  | R  | R  | R  | RW | RW | RW | RW |
| <b>Default</b> | 0           | 0  | 0  | 0  | 0  | 0  | 0  | 0  | 0  | 0  | 0  | 0  | 0  | 0  | 0  | 0  |

Register: **Socket mask**  
 Offset: CardBus Socket Address + 04h  
 Type: Read-only, Read/Write  
 Default: 0000 0000h

**Table 6–3. Socket Mask Register Description**

| BIT  | SIGNAL   | TYPE | FUNCTION  |
|------|----------|------|---|
| 31–4 | RSVD     | R    | These bits return 0s when read.   |
| 3†   | PWRMASK  | RW   | Power cycle. This bit masks the PWRCYCLE bit in the socket present state register (offset 08h, see Section 6.3) from causing a status change interrupt.<br>0 = PWRCYCLE event does not cause a CSC interrupt (default).<br>1 = PWRCYCLE event causes a CSC interrupt.   |
| 2–1† | CDMASK   | RW   | Card detect mask. These bits mask the CDETECT1 and CDETECT2 bits in the socket present state register (offset 08h, see Section 6.3) from causing a CSC interrupt.<br>00 = Insertion/removal does not cause a CSC interrupt (default).<br>01 = Reserved (undefined)<br>10 = Reserved (undefined)<br>11 = Insertion/removal causes a CSC interrupt. |
| 0†   | CSTSMASK | RW   | CSTSCHG mask. This bit masks the CARDSTS field in the socket present state register (offset 08h, see Section 6.3) from causing a CSC interrupt.<br>0 = CARDSTS event does not cause a CSC interrupt (default).<br>1 = CARDSTS event causes a CSC interrupt.   |

† This bit is cleared only by the assertion of  $\overline{GRST}$  when PME is enabled. If PME is not enabled, then this bit is cleared by the assertion of  $\overline{PRST}$  or  $\overline{GRST}$ .

### 6.3 Socket Present State Register

This register reports information about the socket interface. Writes to the socket force event register (offset 0Ch, see Section 6.4), as well as general socket interface status, are reflected here. Information about PC Card  $V_{CC}$  support and card type is only updated at each insertion. Also note that the PCI6x20 device uses the CCD1 and CCD2 signals during card identification, and changes on these signals during this operation are not reflected in this register.

| Bit     | 31                   | 30 | 29 | 28 | 27 | 26 | 25 | 24 | 23 | 22 | 21 | 20 | 19 | 18 | 17 | 16 |
|---------|----------------------|----|----|----|----|----|----|----|----|----|----|----|----|----|----|----|
| Name    | Socket present state |    |    |    |    |    |    |    |    |    |    |    |    |    |    |    |
| Type    | R                    | R  | R  | R  | R  | R  | R  | R  | R  | R  | R  | R  | R  | R  | R  | R  |
| Default | 0                    | 0  | 1  | 1  | 0  | 0  | 0  | 0  | 0  | 0  | 0  | 0  | 0  | 0  | 0  | 0  |
| Bit     | 15                   | 14 | 13 | 12 | 11 | 10 | 9  | 8  | 7  | 6  | 5  | 4  | 3  | 2  | 1  | 0  |
| Name    | Socket present state |    |    |    |    |    |    |    |    |    |    |    |    |    |    |    |
| Type    | R                    | R  | R  | R  | R  | R  | R  | R  | R  | R  | R  | R  | R  | R  | R  | R  |
| Default | 0                    | 0  | 0  | 0  | 0  | 0  | 0  | 0  | 0  | X  | 0  | 0  | 0  | X  | X  | X  |

Register: **Socket present state**  
 Offset: CardBus Socket Address + 08h  
 Type: Read-only  
 Default: 3000 00XXh

**Table 6–4. Socket Present State Register Description**

| BIT   | SIGNAL    | TYPE | FUNCTION  |
|-------|-----------|------|---|
| 31    | YVSOCKET  | R    | YV socket. This bit indicates whether or not the socket can supply $V_{CC} = Y.Y$ V to PC Cards. The PCI6x20 device does not support Y.Y-V $V_{CC}$ ; therefore, this bit is always reset unless overridden by the socket force event register (offset 0Ch, see Section 6.4). This bit defaults to 0. |
| 30    | XVSOCKET  | R    | XV socket. This bit indicates whether or not the socket can supply $V_{CC} = X.X$ V to PC Cards. The PCI6x20 device does not support X.X-V $V_{CC}$ ; therefore, this bit is always reset unless overridden by the socket force event register (offset 0Ch, see Section 6.4). This bit defaults to 0. |
| 29    | 3VSOCKET  | R    | 3-V socket. This bit indicates whether or not the socket can supply $V_{CC} = 3.3$ Vdc to PC Cards. The PCI6x20 device does support 3.3-V $V_{CC}$ ; therefore, this bit is always set unless overridden by the socket force event register (offset 0Ch, see Section 6.4).                            |
| 28    | 5VSOCKET  | R    | 5-V socket. This bit indicates whether or not the socket can supply $V_{CC} = 5$ Vdc to PC Cards. The PCI6x20 device does support 5-V $V_{CC}$ ; therefore, this bit is always set unless overridden by bit 6 of the device control register (PCI offset 92h, see Section 4.39).                      |
| 27–14 | RSVD      | R    | These bits return 0s when read.   |
| 13 †  | YVCARD    | R    | YV card. This bit indicates whether or not the PC Card inserted in the socket supports $V_{CC} = Y.Y$ Vdc. This bit can be set by writing a 1 to the corresponding bit in the socket force event register (offset 0Ch, see Section 6.4).  |
| 12 †  | XVCARD    | R    | XV card. This bit indicates whether or not the PC Card inserted in the socket supports $V_{CC} = X.X$ Vdc. This bit can be set by writing a 1 to the corresponding bit in the socket force event register (offset 0Ch, see Section 6.4).  |
| 11 †  | 3VCARD    | R    | 3-V card. This bit indicates whether or not the PC Card inserted in the socket supports $V_{CC} = 3.3$ Vdc. This bit can be set by writing a 1 to the corresponding bit in the socket force event register (offset 0Ch, see Section 6.4).   |
| 10 †  | 5VCARD    | R    | 5-V card. This bit indicates whether or not the PC Card inserted in the socket supports $V_{CC} = 5$ Vdc. This bit can be set by writing a 1 to the corresponding bit in the socket force event register (offset 0Ch, see Section 6.4).   |
| 9 †   | BADVCCREQ | R    | Bad $V_{CC}$ request. This bit indicates that the host software has requested that the socket be powered at an invalid voltage.<br>0 = Normal operation (default)<br>1 = Invalid $V_{CC}$ request by host software  |

† One or more bits in the register are PME context bits and can be cleared only by the assertion of  $\overline{GRST}$  when  $\overline{PME}$  is enabled. If  $\overline{PME}$  is not enabled, then these bits are cleared by the assertion of  $\overline{PRST}$  or  $\overline{GRST}$ .

**Table 6–4. Socket Present State Register Description (Continued)**

| BIT | SIGNAL    | TYPE | FUNCTION   |
|-----|-----------|------|--|
| 8 † | DATALOST  | R    | Data lost. This bit indicates that a PC Card removal event may have caused lost data because the cycle did not terminate properly or because write data still resides in the PCI16x20 device.<br>0 = Normal operation (default)<br>1 = Potential data loss due to card removal   |
| 7 † | NOTACARD  | R    | Not a card. This bit indicates that an unrecognizable PC Card has been inserted in the socket. This bit is not updated until a valid PC Card is inserted into the socket.<br>0 = Normal operation (default)<br>1 = Unrecognizable PC Card detected   |
| 6   | IREQCINT  | R    | READY( $\overline{\text{IREQ}}$ )/ $\overline{\text{CINT}}$ . This bit indicates the current status of the READY( $\overline{\text{IREQ}}$ )/ $\overline{\text{CINT}}$ signal at the PC Card interface.<br>0 = READY( $\overline{\text{IREQ}}$ )/ $\overline{\text{CINT}}$ is low.<br>1 = READY( $\overline{\text{IREQ}}$ )/ $\overline{\text{CINT}}$ is high. |
| 5 † | CBCARD    | R    | CardBus card detected. This bit indicates that a CardBus PC Card is inserted in the socket. This bit is not updated until another card interrogation sequence occurs (card insertion).   |
| 4 † | 16BITCARD | R    | 16-bit card detected. This bit indicates that a 16-bit PC Card is inserted in the socket. This bit is not updated until another card interrogation sequence occurs (card insertion).   |
| 3 † | PWRCYCLE  | R    | Power cycle. This bit indicates the status of each card powering request. This bit is encoded as:<br>0 = Socket is powered down (default).<br>1 = Socket is powered up.  |
| 2 † | CDETECT2  | R    | $\overline{\text{CCD2}}$ . This bit reflects the current status of the $\overline{\text{CCD2}}$ signal at the PC Card interface. Changes to this signal during card interrogation are not reflected here.<br>0 = $\overline{\text{CCD2}}$ is low (PC Card may be present)<br>1 = $\overline{\text{CCD2}}$ is high (PC Card not present)                        |
| 1 † | CDETECT1  | R    | $\overline{\text{CCD1}}$ . This bit reflects the current status of the $\overline{\text{CCD1}}$ signal at the PC Card interface. Changes to this signal during card interrogation are not reflected here.<br>0 = $\overline{\text{CCD1}}$ is low (PC Card may be present).<br>1 = $\overline{\text{CCD1}}$ is high (PC Card not present).                      |
| 0   | CARDSTS   | R    | CSTSCHG. This bit reflects the current status of the CSTSCHG signal at the PC Card interface.<br>0 = CSTSCHG is low.<br>1 = CSTSCHG is high.   |

† One or more bits in the register are PME context bits and can be cleared only by the assertion of  $\overline{\text{GRST}}$  when  $\overline{\text{PME}}$  is enabled. If  $\overline{\text{PME}}$  is not enabled, then these bits are cleared by the assertion of  $\overline{\text{PRST}}$  or  $\overline{\text{GRST}}$ .

## 6.4 Socket Force Event Register

This register is used to force changes to the socket event register (offset 00h, see Section 6.1) and the socket present state register (offset 08h, see Section 6.3). The CVSTEST bit (bit 14) in this register must be written when forcing changes that require card interrogation. See Table 6–5 for a complete description of the register contents.

|         |                    |    |    |    |    |    |    |    |    |    |    |    |    |    |    |    |
|---------|--------------------|----|----|----|----|----|----|----|----|----|----|----|----|----|----|----|
| Bit     | 31                 | 30 | 29 | 28 | 27 | 26 | 25 | 24 | 23 | 22 | 21 | 20 | 19 | 18 | 17 | 16 |
| Name    | Socket force event |    |    |    |    |    |    |    |    |    |    |    |    |    |    |    |
| Type    | R                  | R  | R  | R  | R  | R  | R  | R  | R  | R  | R  | R  | R  | R  | R  | R  |
| Default | 0                  | 0  | 0  | 0  | 0  | 0  | 0  | 0  | 0  | 0  | 0  | 0  | 0  | 0  | 0  | 0  |
| Bit     | 15                 | 14 | 13 | 12 | 11 | 10 | 9  | 8  | 7  | 6  | 5  | 4  | 3  | 2  | 1  | 0  |
| Name    | Socket force event |    |    |    |    |    |    |    |    |    |    |    |    |    |    |    |
| Type    | R                  | W  | W  | W  | W  | W  | W  | W  | W  | R  | W  | W  | W  | W  | W  | W  |
| Default | X                  | X  | X  | X  | X  | X  | X  | X  | X  | X  | X  | X  | X  | X  | X  | X  |

Register: **Socket force event**  
 Offset: CardBus Socket Address + 0Ch  
 Type: Read-only, Write-only  
 Default: 0000 XXXXh

**Table 6–5. Socket Force Event Register Description**

| BIT   | SIGNAL     | TYPE | FUNCTION  |
|-------|------------|------|---|
| 31–15 | RSVD       | R    | Reserved. These bits return 0s when read.   |
| 14    | CVSTEST    | W    | Card VS test. When this bit is set, the PCI6x20 device reinterrogates the PC Card, updates the socket present state register (offset 08h, see Section 6.3), and re-enables the socket power control.  |
| 13    | FYVCARD    | W    | Force YV card. Writes to this bit cause the YVCARD bit in the socket present state register (offset 08h, see Section 6.3) to be written. When set, this bit disables the socket power control.  |
| 12    | FXVCARD    | W    | Force XV card. Writes to this bit cause the XVCARD bit in the socket present state register (offset 08h, see Section 6.3) to be written. When set, this bit disables the socket power control.  |
| 11    | F3VCARD    | W    | Force 3-V card. Writes to this bit cause the 3VCARD bit in the socket present state register (offset 08h, see Section 6.3) to be written. When set, this bit disables the socket power control.   |
| 10    | F5VCARD    | W    | Force 5-V card. Writes to this bit cause the 5VCARD bit in the socket present state register (offset 08h, see Section 6.3) to be written. When set, this bit disables the socket power control.   |
| 9     | FBADVCCREQ | W    | Force BadVccReq. Changes to the BADVCCREQ bit in the socket present state register (offset 08h, see Section 6.3) can be made by writing this bit.   |
| 8     | FDATALOST  | W    | Force data lost. Writes to this bit cause the DATALOST bit in the socket present state register (offset 08h, see Section 6.3) to be written.  |
| 7     | FNOTACARD  | W    | Force not a card. Writes to this bit cause the NOTACARD bit in the socket present state register (offset 08h, see Section 6.3) to be written.   |
| 6     | RSVD       | R    | This bit returns 0 when read.   |
| 5     | FCBCARD    | W    | Force CardBus card. Writes to this bit cause the CBCARD bit in the socket present state register (offset 08h, see Section 6.3) to be written.   |
| 4     | F16BITCARD | W    | Force 16-bit card. Writes to this bit cause the 16BITCARD bit in the socket present state register (offset 08h, see Section 6.3) to be written.   |
| 3     | FPWRCYCLE  | W    | Force power cycle. Writes to this bit cause the PWREVENT bit in the socket event register (offset 00h, see Section 6.1) to be written, and the PWRCYCLE bit in the socket present state register (offset 08h, see Section 6.3) is unaffected. |
| 2     | FCDETECT2  | W    | Force CCD2. Writes to this bit cause the CD2EVENT bit in the socket event register (offset 00h, see Section 6.1) to be written, and the CDETECT2 bit in the socket present state register (offset 08h, see Section 6.3) is unaffected.        |
| 1     | FCDETECT1  | W    | Force CCD1. Writes to this bit cause the CD1EVENT bit in the socket event register (offset 00h, see Section 6.1) to be written, and the CDETECT1 bit in the socket present state register (offset 08h, see Section 6.3) is unaffected.        |
| 0     | FCARDSTS   | W    | Force CSTSCHG. Writes to this bit cause the CSTSEVENT bit in the socket event register (offset 00h, see Section 6.1) to be written. The CARDSTS bit in the socket present state register (offset 08h, see Section 6.3) is unaffected.         |

## 6.5 Socket Control Register

This register provides control of the voltages applied to the socket  $V_{PP}$  and  $V_{CC}$ . The PCI6x20 device ensures that the socket is powered up only at acceptable voltages when a CardBus card is inserted. See Table 6–6 for a complete description of the register contents.

|                |                |    |    |    |    |    |    |    |    |    |    |    |    |    |    |    |
|----------------|----------------|----|----|----|----|----|----|----|----|----|----|----|----|----|----|----|
| <b>Bit</b>     | 31             | 30 | 29 | 28 | 27 | 26 | 25 | 24 | 23 | 22 | 21 | 20 | 19 | 18 | 17 | 16 |
| <b>Name</b>    | Socket control |    |    |    |    |    |    |    |    |    |    |    |    |    |    |    |
| <b>Type</b>    | R              | R  | R  | R  | R  | R  | R  | R  | R  | R  | R  | R  | R  | R  | R  | R  |
| <b>Default</b> | 0              | 0  | 0  | 0  | 0  | 0  | 0  | 0  | 0  | 0  | 0  | 0  | 0  | 0  | 0  | 0  |
| <b>Bit</b>     | 15             | 14 | 13 | 12 | 11 | 10 | 9  | 8  | 7  | 6  | 5  | 4  | 3  | 2  | 1  | 0  |
| <b>Name</b>    | Socket control |    |    |    |    |    |    |    |    |    |    |    |    |    |    |    |
| <b>Type</b>    | R              | R  | R  | R  | R  | R  | RW | R  | RW | RW | RW | RW | R  | RW | RW | RW |
| <b>Default</b> | 0              | 0  | 0  | 0  | 0  | 0  | 0  | 0  | 0  | 0  | 0  | 0  | 0  | 0  | 0  | 0  |

Register: **Socket control**  
 Offset: CardBus Socket Address + 10h  
 Type: Read-only, Read/Write  
 Default: 0000 0000h

**Table 6–6. Socket Control Register Description**

| BIT   | SIGNAL  | TYPE | FUNCTION  |
|-------|---------|------|---|
| 31–11 | RSVD    | R    | These bits return 0s when read.   |
| 10    | RSVD    | R    | This bit returns 1 when read.   |
| 9–8   | RSVD    | R    | These bits return 0s when read.   |
| 7     | STOPCLK | RW   | This bit controls how the CardBus clock run state machine decides when to stop the CardBus clock to the CardBus card:<br>0 = The CardBus $\overline{\text{CLKRUN}}$ protocol can only attempt to stop/slow the CardBus clock if the socket has been idle for 8 clocks and the PCI $\overline{\text{CLKRUN}}$ protocol is preparing to stop/slow the PCI bus clock.<br>1 = The CardBus $\overline{\text{CLKRUN}}$ protocol can only attempt to stop/slow the CardBus clock if the socket has been idle for 8 clocks, regardless of the state of the PCI $\overline{\text{CLKRUN}}$ signal. |
| 6–4 † | VCCCTRL | RW   | $V_{CC}$ control. These bits are used to request card $V_{CC}$ changes.<br>000 = Request power off (default)      100 = Request $V_{CC} = X.X$ V<br>001 = Reserved                              101 = Request $V_{CC} = Y.Y$ V<br>010 = Request $V_{CC} = 5$ V              110 = Reserved<br>011 = Request $V_{CC} = 3.3$ V            111 = Reserved  |
| 3     | RSVD    | R    | This bit returns 0 when read.   |
| 2–0 † | VPPCTRL | RW   | $V_{PP}$ control. These bits are used to request card $V_{PP}$ changes.<br>000 = Request power off (default)      100 = Request $V_{PP} = X.X$ V<br>001 = Request $V_{PP} = 12$ V              101 = Request $V_{PP} = Y.Y$ V<br>010 = Request $V_{PP} = 5$ V                110 = Reserved<br>011 = Request $V_{PP} = 3.3$ V            111 = Reserved   |

† One or more bits in the register are PME context bits and can be cleared only by the assertion of  $\overline{\text{GRST}}$  when PME is enabled. If PME is not enabled, then this bit is cleared by the assertion of  $\overline{\text{PRST}}$  or  $\overline{\text{GRST}}$ .

## 6.6 Socket Power Management Register

This register provides power management control over the socket through a mechanism for slowing or stopping the clock on the card interface when the card is idle. See Table 6–7 for a complete description of the register contents.

| Bit     | 31                      | 30 | 29 | 28 | 27 | 26 | 25 | 24 | 23 | 22 | 21 | 20 | 19 | 18 | 17 | 16 |
|---------|-------------------------|----|----|----|----|----|----|----|----|----|----|----|----|----|----|----|
| Name    | Socket power management |    |    |    |    |    |    |    |    |    |    |    |    |    |    |    |
| Type    | R                       | R  | R  | R  | R  | R  | R  | R  | R  | R  | R  | R  | R  | R  | R  | RW |
| Default | 0                       | 0  | 0  | 0  | 0  | 0  | 0  | 0  | 0  | 0  | 0  | 0  | 0  | 0  | 0  | 0  |
| Bit     | 15                      | 14 | 13 | 12 | 11 | 10 | 9  | 8  | 7  | 6  | 5  | 4  | 3  | 2  | 1  | 0  |
| Name    | Socket power management |    |    |    |    |    |    |    |    |    |    |    |    |    |    |    |
| Type    | R                       | R  | R  | R  | R  | R  | R  | R  | R  | R  | R  | R  | R  | R  | R  | RW |
| Default | 0                       | 0  | 0  | 0  | 0  | 0  | 0  | 0  | 0  | 0  | 0  | 0  | 0  | 0  | 0  | 0  |

Register: **Socket power management**  
 Offset: CardBus Socket Address + 20h  
 Type: Read-only, Read/Write  
 Default: 0000 0000h

**Table 6–7. Socket Power Management Register Description**

| BIT   | SIGNAL     | TYPE | FUNCTION  |
|-------|------------|------|---|
| 31–26 | RSVD       | R    | Reserved. These bits return 0s when read.   |
| 25 ‡  | SKTACCES   | R    | Socket access status. This bit provides information on whether a socket access has occurred. This bit is cleared by a read access.<br>0 = No PC Card access has occurred (default).<br>1 = PC Card has been accessed.   |
| 24 ‡  | SKTMODE    | R    | Socket mode status. This bit provides clock mode information.<br>0 = Normal clock operation<br>1 = Clock frequency has changed.   |
| 23–17 | RSVD       | R    | These bits return 0s when read.   |
| 16    | CLKCTRLLEN | RW   | CardBus clock control enable. This bit, when set, enables clock control according to bit 0 (CLKCTRL).<br>0 = Clock control disabled (default)<br>1 = Clock control enabled  |
| 15–1  | RSVD       | R    | These bits return 0s when read.   |
| 0     | CLKCTRL    | RW   | CardBus clock control. This bit determines whether the CardBus <u>CLKRUN</u> protocol attempts to stop or slow the CardBus clock during idle states. The CLKCTRLLEN bit enables this bit.<br>0 = Allows the CardBus <u>CLKRUN</u> protocol to attempt to stop the CardBus clock (default)<br>1 = Allows the CardBus <u>CLKRUN</u> protocol to attempt to slow the CardBus clock by a factor of 16 |

‡ One or more bits in this register are cleared only by the assertion of GRST.

## 7 Flash Media Controller Programming Model

This section describes the internal PCI configuration registers used to program the PCI6x20 flash media controller interface. All registers are detailed in the same format: a brief description for each register is followed by the register offset and a bit table describing the reset state for each register.

A bit description table, typically included when the register contains bits of more than one type or purpose, indicates bit field names, a detailed field description, and field access tags which appear in the *type* column. Table 4–1 describes the field access tags.

PCI6x20 device is a multifunction PCI device. The flash media controller core is integrated as PCI function 3. The function 3 configuration header is compliant with the *PCI Local Bus Specification* as a standard header. Table 7–1 illustrates the configuration header that includes both the predefined portion of the configuration space and the user-definable registers.

**Table 7–1. Function 3 Configuration Register Map**

| REGISTER NAME                 |               |                                       |   | OFFSET  |
|-------------------------------|---------------|---------------------------------------|---|---------|
| Device ID                     |               | Vendor ID                             |   | 00h     |
| Status                        |               | Command                               |   | 04h     |
| Class code                    |               |                                       | Revision ID                               | 08h     |
| BIST                          | Header type   | Latency timer                         | Cache line size                           | 0Ch     |
| Flash media base address      |               |                                       |   | 10h     |
| Reserved                      |               |                                       |   | 14h–28h |
| Subsystem ID ‡                |               | Subsystem vendor ID ‡                 |   | 2Ch     |
| Reserved                      |               |                                       |   | 30h     |
| Reserved                      |               |                                       | PCI power management capabilities pointer | 34h     |
| Reserved                      |               |                                       |   | 38h     |
| Maximum latency               | Minimum grant | Interrupt pin                         | Interrupt line                            | 3Ch     |
| Reserved                      |               |                                       |   | 40h     |
| Power management capabilities |               | Next item pointer                     | Capability ID                             | 44h     |
| PM data (Reserved)            | PMCSR_BSE     | Power management control and status ‡ |   | 48h     |
| Reserved                      |               | General control ‡                     |   | 4Ch     |
| Subsystem access              |               |                                       |   | 50h     |
| Diagnostic ‡                  |               |                                       |   | 54h     |
| Reserved                      |               |                                       |   | 58h–FCh |

‡ One or more bits in this register are cleared only by the assertion of  $\overline{\text{GRST}}$ .

## 7.1 Vendor ID Register

The vendor ID register contains a value allocated by the PCI SIG and identifies the manufacturer of the PCI device. The vendor ID assigned to Texas Instruments is 104Ch.

| Bit     | 15        | 14 | 13 | 12 | 11 | 10 | 9 | 8 | 7 | 6 | 5 | 4 | 3 | 2 | 1 | 0 |
|---------|-----------|----|----|----|----|----|---|---|---|---|---|---|---|---|---|---|
| Name    | Vendor ID |    |    |    |    |    |   |   |   |   |   |   |   |   |   |   |
| Type    | R         | R  | R  | R  | R  | R  | R | R | R | R | R | R | R | R | R | R |
| Default | 0         | 0  | 0  | 1  | 0  | 0  | 0 | 0 | 0 | 1 | 0 | 0 | 1 | 1 | 0 | 0 |

Register: **Vendor ID**  
 Offset: 00h  
 Type: Read-only  
 Default: 104Ch

## 7.2 Device ID Register

The device ID register contains a value assigned to the flash media controller by Texas Instruments. The device identification for the flash media controller is AC8Fh.

| Bit     | 15        | 14 | 13 | 12 | 11 | 10 | 9 | 8 | 7 | 6 | 5 | 4 | 3 | 2 | 1 | 0 |
|---------|-----------|----|----|----|----|----|---|---|---|---|---|---|---|---|---|---|
| Name    | Device ID |    |    |    |    |    |   |   |   |   |   |   |   |   |   |   |
| Type    | R         | R  | R  | R  | R  | R  | R | R | R | R | R | R | R | R | R | R |
| Default | 1         | 0  | 1  | 0  | 1  | 1  | 0 | 0 | 1 | 0 | 0 | 0 | 1 | 1 | 1 | 1 |

Register: **Device ID**  
 Offset: 02h  
 Type: Read-only  
 Default: AC8Fh

### 7.3 Command Register

The command register provides control over the PCI6x20 interface to the PCI bus. All bit functions adhere to the definitions in the *PCI Local Bus Specification*, as seen in the following bit descriptions. See Table 7–2 for a complete description of the register contents.

| Bit     | 15      | 14 | 13 | 12 | 11 | 10 | 9 | 8  | 7 | 6  | 5 | 4  | 3 | 2  | 1  | 0 |
|---------|---------|----|----|----|----|----|---|----|---|----|---|----|---|----|----|---|
| Name    | Command |    |    |    |    |    |   |    |   |    |   |    |   |    |    |   |
| Type    | R       | R  | R  | R  | R  | RW | R | RW | R | RW | R | RW | R | RW | RW | R |
| Default | 0       | 0  | 0  | 0  | 0  | 0  | 0 | 0  | 0 | 0  | 0 | 0  | 0 | 0  | 0  | 0 |

Register: **Command**  
 Offset: 04h  
 Type: Read/Write, Read-only  
 Default: 0000h

**Table 7–2. Command Register Description**

| BIT   | FIELD NAME  | TYPE | DESCRIPTION   |
|-------|-------------|------|---|
| 15–11 | RSVD        | R    | Reserved. Bits 15–11 return 0s when read.   |
| 10    | INT_DISABLE | RW   | $\overline{\text{INTx}}$ disable. When set to 1, this bit disables the function from asserting interrupts on the $\overline{\text{INTx}}$ signals.<br>0 = $\overline{\text{INTx}}$ assertion is enabled (default)<br>1 = $\overline{\text{INTx}}$ assertion is disabled |
| 9     | FBB_ENB     | R    | Fast back-to-back enable. The flash media interface does not generate fast back-to-back transactions; therefore, bit 9 returns 0 when read.   |
| 8     | SERR_ENB    | RW   | $\overline{\text{SERR}}$ enable. When bit 8 is set to 1, the flash media interface $\overline{\text{SERR}}$ driver is enabled. $\overline{\text{SERR}}$ can be asserted after detecting an address parity error on the PCI bus.   |
| 7     | STEP_ENB    | R    | Address/data stepping control. The flash media interface does not support address/data stepping; therefore, bit 7 is hardwired to 0.  |
| 6     | PERR_ENB    | RW   | Parity error enable. When bit 6 is set to 1, the flash media interface is enabled to drive $\overline{\text{PERR}}$ response to parity errors through the $\overline{\text{PERR}}$ signal.  |
| 5     | VGA_ENB     | R    | VGA palette snoop enable. The flash media interface does not feature VGA palette snooping; therefore, bit 5 returns 0 when read.  |
| 4     | MWI_ENB     | RW   | Memory write and invalidate enable. The flash media controller does not generate memory write invalidate transactions; therefore, bit 4 returns 0 when read.  |
| 3     | SPECIAL     | R    | Special cycle enable. The flash media interface does not respond to special cycle transactions; therefore, bit 3 returns 0 when read.   |
| 2     | MASTER_ENB  | RW   | Bus master enable. When bit 2 is set to 1, the flash media interface is enabled to initiate cycles on the PCI bus.  |
| 1     | MEMORY_ENB  | RW   | Memory response enable. Setting bit 1 to 1 enables the flash media interface to respond to memory cycles on the PCI bus.  |
| 0     | IO_ENB      | R    | I/O space enable. The flash media interface does not implement any I/O-mapped functionality; therefore, bit 0 returns 0 when read.  |

## 7.4 Status Register

The status register provides device information to the host system. All bit functions adhere to the definitions in the *PCI Local Bus Specification*, as seen in the following bit descriptions. Bits in this register may be read normally. A bit in the status register is reset when a 1 is written to that bit location; a 0 written to a bit location has no effect. See Table 7–3 for a complete description of the register contents.

| Bit     | 15     | 14  | 13  | 12  | 11  | 10 | 9 | 8   | 7 | 6 | 5 | 4 | 3  | 2 | 1 | 0 |
|---------|--------|-----|-----|-----|-----|----|---|-----|---|---|---|---|----|---|---|---|
| Name    | Status |     |     |     |     |    |   |     |   |   |   |   |    |   |   |   |
| Type    | RCU    | RCU | RCU | RCU | RCU | R  | R | RCU | R | R | R | R | RU | R | R | R |
| Default | 0      | 0   | 0   | 0   | 0   | 0  | 1 | 0   | 0 | 0 | 0 | 1 | 0  | 0 | 0 | 0 |

Register: **Status**  
 Offset: 06h  
 Type: Read/Clear/Update, Read-only  
 Default: 0210h

**Table 7–3. Status Register Description**

| BIT  | FIELD NAME | TYPE | DESCRIPTION   |
|------|------------|------|---|
| 15   | PAR_ERR    | RCU  | Detected parity error. Bit 15 is set to 1 when either an address parity or data parity error is detected.   |
| 14   | SYS_ERR    | RCU  | Signaled system error. Bit 14 is set to 1 when $\overline{SERR}$ is enabled and the flash media controller has signaled a system error to the host.   |
| 13   | MABORT     | RCU  | Received master abort. Bit 13 is set to 1 when a cycle initiated by the flash media controller on the PCI bus has been terminated by a master abort.  |
| 12   | TABORT_REC | RCU  | Received target abort. Bit 12 is set to 1 when a cycle initiated by the flash media controller on the PCI bus was terminated by a target abort.   |
| 11   | TABORT_SIG | RCU  | Signaled target abort. Bit 11 is set to 1 by the flash media controller when it terminates a transaction on the PCI bus with a target abort.  |
| 10–9 | PCI_SPEED  | R    | DEVSEL timing. Bits 10 and 9 encode the timing of $\overline{DEVSEL}$ and are hardwired to 01b, indicating that the flash media controller asserts this signal at a medium speed on nonconfiguration cycle accesses.  |
| 8    | DATAPAR    | RCU  | Data parity error detected. Bit 8 is set to 1 when the following conditions have been met:<br>a. $\overline{PERR}$ was asserted by any PCI device including the flash media controller.<br>b. The flash media controller was the bus master during the data parity error.<br>c. Bit 6 (PERR_EN) in the command register at offset 04h in the PCI configuration space (see Section 7.3) is set to 1.   |
| 7    | FBB_CAP    | R    | Fast back-to-back capable. The flash media controller cannot accept fast back-to-back transactions; therefore, bit 7 is hardwired to 0.   |
| 6    | UDF        | R    | User-definable features (UDF) supported. The flash media controller does not support the UDF; therefore, bit 6 is hardwired to 0.   |
| 5    | 66MHZ      | R    | 66-MHz capable. The flash media controller operates at a maximum PCLK frequency of 33 MHz; therefore, bit 5 is hardwired to 0.  |
| 4    | CAPLIST    | R    | Capabilities list. Bit 4 returns 1 when read, indicating that the flash media controller supports additional PCI capabilities.  |
| 3    | INT_STATUS | RU   | Interrupt status. This bit reflects the interrupt status of the function. Only when bit 10 (INT_DISABLE) in the command register (see Section 7.3) is a 0 and this bit is 1, is the function's $\overline{INTx}$ signal asserted. Setting the INT_DISABLE bit to 1 has no effect on the state of this bit. This bit is set only when a valid interrupt condition exists. This bit is not set when an interrupt condition exists and signaling of that event is not enabled. |
| 2–0  | RSVD       | R    | Reserved. Bits 3–0 return 0s when read.   |

## 7.5 Class Code and Revision ID Register

The class code and revision ID register categorizes the base class, subclass, and programming interface of the function. The base class is 01h, identifying the device as a mass storage controller. The subclass is 80h, identifying the function as other mass storage controller, and the programming interface is 00h. Furthermore, the TI chip revision is indicated in the least significant byte (00h). See Table 7–4 for a complete description of the register contents.

| Bit            | 31                         | 30 | 29 | 28 | 27 | 26 | 25 | 24 | 23 | 22 | 21 | 20 | 19 | 18 | 17 | 16 |
|----------------|----------------------------|----|----|----|----|----|----|----|----|----|----|----|----|----|----|----|
| <b>Name</b>    | Class code and revision ID |    |    |    |    |    |    |    |    |    |    |    |    |    |    |    |
| <b>Type</b>    | R                          | R  | R  | R  | R  | R  | R  | R  | R  | R  | R  | R  | R  | R  | R  | R  |
| <b>Default</b> | 0                          | 0  | 0  | 0  | 0  | 0  | 0  | 1  | 1  | 0  | 0  | 0  | 0  | 0  | 0  | 0  |
| Bit            | 15                         | 14 | 13 | 12 | 11 | 10 | 9  | 8  | 7  | 6  | 5  | 4  | 3  | 2  | 1  | 0  |
| <b>Name</b>    | Class code and revision ID |    |    |    |    |    |    |    |    |    |    |    |    |    |    |    |
| <b>Type</b>    | R                          | R  | R  | R  | R  | R  | R  | R  | R  | R  | R  | R  | R  | R  | R  | R  |
| <b>Default</b> | 0                          | 0  | 0  | 0  | 0  | 0  | 0  | 0  | 0  | 0  | 0  | 0  | 0  | 0  | 0  | 0  |

Register: **Class code and revision ID**  
 Offset: 08h  
 Type: Read-only  
 Default: 0180 0000h

**Table 7–4. Class Code and Revision ID Register Description**

| BIT   | FIELD NAME | TYPE | DESCRIPTION  |
|-------|------------|------|--|
| 31–24 | BASECLASS  | R    | Base class. This field returns 01h when read, which classifies the function as a mass storage controller.                |
| 23–16 | SUBCLASS   | R    | Subclass. This field returns 80h when read, which specifically classifies the function as other mass storage controller. |
| 15–8  | PGMIF      | R    | Programming interface. This field returns 00h when read.   |
| 7–0   | CHIPREV    | R    | Silicon revision. This field returns 00h when read, which indicates the silicon revision of the flash media controller.  |

## 7.6 Latency Timer and Class Cache Line Size Register

The latency timer and class cache line size register is programmed by host BIOS to indicate system cache line size and the latency timer associated with the flash media controller. See Table 7–5 for a complete description of the register contents.

| Bit            | 15                                      | 14 | 13 | 12 | 11 | 10 | 9  | 8  | 7  | 6  | 5  | 4  | 3  | 2  | 1  | 0  |
|----------------|---|----|----|----|----|----|----|----|----|----|----|----|----|----|----|----|
| <b>Name</b>    | Latency timer and class cache line size |    |    |    |    |    |    |    |    |    |    |    |    |    |    |    |
| <b>Type</b>    | RW                                      | RW | RW | RW | RW | RW | RW | RW | RW | RW | RW | RW | RW | RW | RW | RW |
| <b>Default</b> | 0                                       | 0  | 0  | 0  | 0  | 0  | 0  | 0  | 0  | 0  | 0  | 0  | 0  | 0  | 0  | 0  |

Register: **Latency timer and class cache line size**  
 Offset: 0Ch  
 Type: Read/Write  
 Default: 0000h

**Table 7–5. Latency Timer and Class Cache Line Size Register Description**

| BIT  | FIELD NAME    | TYPE | DESCRIPTION  |
|------|---------------|------|--|
| 15–8 | LATENCY_TIMER | RW   | PCI latency timer. The value in this register specifies the latency timer for the flash media controller, in units of PCI clock cycles. When the flash media controller is a PCI bus initiator and asserts <code>FRAME</code> , the latency timer begins counting from zero. If the latency timer expires before the flash media transaction has terminated, then the flash media controller terminates the transaction when its <code>GNT</code> is deasserted. |
| 7–0  | CACHELINE_SZ  | RW   | Cache line size. This value is used by the flash media controller during memory write and invalidate, memory-read line, and memory-read multiple transactions.   |

## 7.7 Header Type and BIST Register

The header type and built-in self-test (BIST) register indicates the flash media controller PCI header type and no built-in self-test. See Table 7–6 for a complete description of the register contents.

| Bit     | 15                   | 14 | 13 | 12 | 11 | 10 | 9 | 8 | 7 | 6 | 5 | 4 | 3 | 2 | 1 | 0 |
|---------|----------------------|----|----|----|----|----|---|---|---|---|---|---|---|---|---|---|
| Name    | Header type and BIST |    |    |    |    |    |   |   |   |   |   |   |   |   |   |   |
| Type    | R                    | R  | R  | R  | R  | R  | R | R | R | R | R | R | R | R | R | R |
| Default | 0                    | 0  | 0  | 0  | 0  | 0  | 0 | 0 | x | 0 | 0 | 0 | 0 | 0 | 0 | 0 |

Register: **Header type and BIST**  
 Offset: 0Eh  
 Type: Read-only  
 Default: 00x0h

**Table 7–6. Header Type and BIST Register Description**

| BIT  | FIELD NAME  | TYPE | DESCRIPTION  |
|------|-------------|------|--|
| 15–8 | BIST        | R    | Built-in self-test. The flash media controller does not include a BIST; therefore, this field returns 00h when read.                           |
| 7–0  | HEADER_TYPE | R    | PCI header type. The flash media controller includes the standard PCI header. Bit 7 indicates if the flash media is in a multifunction device. |

## 7.8 Flash Media Base Address Register

The flash media base address register specifies the base address of the memory-mapped interface registers. Since the implementation of the flash media controller core in the PCI6x20 device contains 2 sockets, the size of the base address register is 4096 bytes. See Table 7–7 for a complete description of the register contents.

| Bit     | 31                       | 30 | 29 | 28 | 27 | 26 | 25 | 24 | 23 | 22 | 21 | 20 | 19 | 18 | 17 | 16 |
|---------|--------------------------|----|----|----|----|----|----|----|----|----|----|----|----|----|----|----|
| Name    | Flash media base address |    |    |    |    |    |    |    |    |    |    |    |    |    |    |    |
| Type    | RW                       | RW | RW | RW | RW | RW | RW | RW | RW | RW | RW | RW | RW | RW | RW | RW |
| Default | 0                        | 0  | 0  | 0  | 0  | 0  | 0  | 0  | 0  | 0  | 0  | 0  | 0  | 0  | 0  | 0  |
| Bit     | 15                       | 14 | 13 | 12 | 11 | 10 | 9  | 8  | 7  | 6  | 5  | 4  | 3  | 2  | 1  | 0  |
| Name    | Flash media base address |    |    |    |    |    |    |    |    |    |    |    |    |    |    |    |
| Type    | RW                       | RW | RW | RW | RW | R  | R  | R  | R  | R  | R  | R  | R  | R  | R  | R  |
| Default | 0                        | 0  | 0  | 0  | 0  | 0  | 0  | 0  | 0  | 0  | 0  | 0  | 0  | 0  | 0  | 0  |

Register: **Flash media base address**  
 Offset: 10h  
 Type: Read/Write, Read-only  
 Default: 0000 0000h

**Table 7–7. Flash Media Base Address Register Description**

| BIT   | FIELD NAME    | TYPE | DESCRIPTION   |
|-------|---------------|------|---|
| 31–12 | BAR           | RW   | Base address. This field specifies the upper bits of the 32-bit starting base address.                    |
| 11–4  | RSVD          | R    | Reserved. Bits 11–4 return 0s when read to indicate that the size of the base address is 4096 bytes.      |
| 3     | PREFETCHABLE  | R    | Prefetchable. Since this base address is not prefetchable, bit 3 returns 0 when read.                     |
| 2–1   | RSVD          | R    | Reserved. Bits 2–1 return 0s when read.   |
| 0     | MEM_INDICATOR | R    | Memory space indicator. Bit 0 is hardwired to 0 to indicate that the base address maps into memory space. |

## 7.9 Subsystem Vendor Identification Register

The subsystem identification register, used for system and option card identification purposes, may be required for certain operating systems. This read-only register is initialized through the EEPROM and can be written through the subsystem access register at PCI offset 50h (see Section 7.22). All bits in this register are reset by  $\overline{\text{GRST}}$  only.

| Bit     | 15                              | 14 | 13 | 12 | 11 | 10 | 9  | 8  | 7  | 6  | 5  | 4  | 3  | 2  | 1  | 0  |
|---------|---------------------------------|----|----|----|----|----|----|----|----|----|----|----|----|----|----|----|
| Name    | Subsystem vendor identification |    |    |    |    |    |    |    |    |    |    |    |    |    |    |    |
| Type    | RU                              | RU | RU | RU | RU | RU | RU | RU | RU | RU | RU | RU | RU | RU | RU | RU |
| Default | 0                               | 0  | 0  | 0  | 0  | 0  | 0  | 0  | 0  | 0  | 0  | 0  | 0  | 0  | 0  | 0  |

Register: **Subsystem vendor identification**  
 Offset: 2Ch  
 Type: Read/Update  
 Default: 0000h

## 7.10 Subsystem Identification Register

The subsystem identification register, used for system and option card identification purposes, may be required for certain operating systems. This read-only register is initialized through the EEPROM and can be written through the subsystem access register at PCI offset 50h (see Section 7.22). All bits in this register are reset by  $\overline{\text{GRST}}$  only.

| Bit     | 15                       | 14 | 13 | 12 | 11 | 10 | 9  | 8  | 7  | 6  | 5  | 4  | 3  | 2  | 1  | 0  |
|---------|--------------------------|----|----|----|----|----|----|----|----|----|----|----|----|----|----|----|
| Name    | Subsystem identification |    |    |    |    |    |    |    |    |    |    |    |    |    |    |    |
| Type    | RU                       | RU | RU | RU | RU | RU | RU | RU | RU | RU | RU | RU | RU | RU | RU | RU |
| Default | 0                        | 0  | 0  | 0  | 0  | 0  | 0  | 0  | 0  | 0  | 0  | 0  | 0  | 0  | 0  | 0  |

Register: **Subsystem identification**  
 Offset: 2Eh  
 Type: Read/Update  
 Default: 0000h

## 7.11 Capabilities Pointer Register

The power management capabilities pointer register provides a pointer into the PCI configuration header where the power-management register block resides. Since the PCI power management registers begin at 44h, this read-only register is hardwired to 44h.

| Bit     | 7                    | 6 | 5 | 4 | 3 | 2 | 1 | 0 |
|---------|----------------------|---|---|---|---|---|---|---|
| Name    | Capabilities pointer |   |   |   |   |   |   |   |
| Type    | R                    | R | R | R | R | R | R | R |
| Default | 0                    | 1 | 0 | 0 | 0 | 1 | 0 | 0 |

Register: **Capabilities pointer**  
 Offset: 34h  
 Type: Read-only  
 Default: 44h

## 7.12 Interrupt Line Register

The interrupt line register is programmed by the system and indicates to the software which interrupt line the flash media interface has assigned to it. The default value of this register is FFh, indicating that an interrupt line has not yet been assigned to the function.

| Bit     | 7              | 6  | 5  | 4  | 3  | 2  | 1  | 0  |
|---------|----------------|----|----|----|----|----|----|----|
| Name    | Interrupt line |    |    |    |    |    |    |    |
| Type    | RW             | RW | RW | RW | RW | RW | RW | RW |
| Default | 1              | 1  | 1  | 1  | 1  | 1  | 1  | 1  |

Register: **Interrupt line**  
 Offset: 3Ch  
 Type: Read/Write  
 Default: FFh

## 7.13 Interrupt Pin Register

This register decodes the interrupt select inputs and returns the proper interrupt value based on Table 7–8, indicating that the flash media interface uses an interrupt. If one of the USE\_INTx terminals is asserted, the interrupt select bits are ignored, and this register returns the interrupt value for the highest priority USE\_INTx terminal that is asserted. If bit 28, the tie-all bit (TIEALL), in the system control register (PCI offset 80h, see Section 4.29) is set to 1, then the PCI6x20 device asserts the USE\_INTA input to the flash media controller core. If bit 28 (TIEALL) in the system control register (PCI offset 80h, see Section 4.29) is set to 0, then none of the USE\_INTx inputs are asserted and the interrupt for the flash media function is selected by the INT\_SEL bits in the flash media general control register.

| Bit     | 7             | 6 | 5 | 4 | 3 | 2 | 1 | 0 |
|---------|---------------|---|---|---|---|---|---|---|
| Name    | Interrupt pin |   |   |   |   |   |   |   |
| Type    | R             | R | R | R | R | R | R | R |
| Default | 0             | 0 | 0 | 0 | 0 | X | X | X |

Register: **Interrupt pin**  
 Offset: 3Dh  
 Type: Read-only  
 Default: 0Xh

**Table 7–8. PCI Interrupt Pin Register**

| INT_SEL BITS | USE_INTA | INTPIN                           |
|--------------|----------|----------------------------------|
| 00           | 0        | 01h ( $\overline{\text{INTA}}$ ) |
| 01           | 0        | 02h ( $\overline{\text{INTB}}$ ) |
| 10           | 0        | 03h ( $\overline{\text{INTC}}$ ) |
| 11           | 0        | 04h ( $\overline{\text{INTD}}$ ) |
| XX           | 1        | 01h ( $\overline{\text{INTA}}$ ) |

## 7.14 Minimum Grant Register

The minimum grant register contains the minimum grant value for the flash media controller core.

| Bit     | 7             | 6  | 5  | 4  | 3  | 2  | 1  | 0  |
|---------|---------------|----|----|----|----|----|----|----|
| Name    | Minimum grant |    |    |    |    |    |    |    |
| Type    | RU            | RU | RU | RU | RU | RU | RU | RU |
| Default | 0             | 0  | 0  | 0  | 0  | 1  | 1  | 1  |

Register: **Minimum grant**  
 Offset: 3Eh  
 Type: Read/Update  
 Default: 07h

**Table 7–9. Minimum Grant Register Description**

| BIT   | FIELD NAME | TYPE | DESCRIPTION  |
|-------|------------|------|--|
| 7–0 ‡ | MIN_GNT    | RU   | Minimum grant. The contents of this field may be used by host BIOS to assign a latency timer register value to the flash media controller. The default for this register indicates that the flash media controller may need to sustain burst transfers for nearly 64 $\mu$ s and thus request a large value be programmed in bits 15–8 of the PCI6x20 latency timer and class cache line size register at offset 0Ch in the PCI configuration space (see Section 7.6). |

‡ One or more bits in this register are cleared only by the assertion of  $\overline{\text{GRST}}$ .

## 7.15 Maximum Latency Register

The maximum latency register contains the maximum latency value for the flash media controller core.

| Bit     | 7               | 6  | 5  | 4  | 3  | 2  | 1  | 0  |
|---------|-----------------|----|----|----|----|----|----|----|
| Name    | Maximum latency |    |    |    |    |    |    |    |
| Type    | RU              | RU | RU | RU | RU | RU | RU | RU |
| Default | 0               | 0  | 0  | 0  | 0  | 1  | 0  | 0  |

Register: **Maximum latency**  
 Offset: 3Eh  
 Type: Read/Update  
 Default: 04h

**Table 7–10. Maximum Latency Register Description**

| BIT   | FIELD NAME | TYPE | DESCRIPTION  |
|-------|------------|------|--|
| 7–0 ‡ | MAX_LAT    | RU   | Maximum latency. The contents of this field may be used by host BIOS to assign an arbitration priority level to the flash media controller. The default for this register indicates that the flash media controller may need to access the PCI bus as often as every 0.25 $\mu$ s; thus, an extremely high priority level is requested. The contents of this field may also be loaded through the serial EEPROM. |

‡ One or more bits in this register are cleared only by the assertion of  $\overline{\text{GRST}}$ .

## 7.16 Capability ID and Next Item Pointer Registers

The capability ID and next item pointer register identifies the linked-list capability item and provides a pointer to the next capability item. See Table 7–11 for a complete description of the register contents.

| Bit            | 15                                  | 14 | 13 | 12 | 11 | 10 | 9 | 8 | 7 | 6 | 5 | 4 | 3 | 2 | 1 | 0 |
|----------------|-------------------------------------|----|----|----|----|----|---|---|---|---|---|---|---|---|---|---|
| <b>Name</b>    | Capability ID and next item pointer |    |    |    |    |    |   |   |   |   |   |   |   |   |   |   |
| <b>Type</b>    | R                                   | R  | R  | R  | R  | R  | R | R | R | R | R | R | R | R | R | R |
| <b>Default</b> | 0                                   | 0  | 0  | 0  | 0  | 0  | 0 | 0 | 0 | 0 | 0 | 0 | 0 | 0 | 0 | 1 |

Register: **Capability ID and next item pointer**  
 Offset: 44h  
 Type: Read-only  
 Default: 0001h

**Table 7–11. Capability ID and Next Item Pointer Registers Description**

| BIT  | FIELD NAME    | TYPE | DESCRIPTION  |
|------|---------------|------|--|
| 15–8 | NEXT_ITEM     | R    | Next item pointer. The flash media controller supports only one additional capability, PCI power management, that is communicated to the system through the extended capabilities list; therefore, this field returns 00h when read. |
| 7–0  | CAPABILITY_ID | R    | Capability identification. This field returns 01h when read, which is the unique ID assigned by the PCI SIG for PCI power-management capability.   |

## 7.17 Power Management Capabilities Register

The power management capabilities register indicates the capabilities of the flash media controller related to PCI power management. See Table 7–12 for a complete description of the register contents.

| Bit     | 15                            | 14 | 13 | 12 | 11 | 10 | 9 | 8 | 7 | 6 | 5 | 4 | 3 | 2 | 1 | 0 |
|---------|-------------------------------|----|----|----|----|----|---|---|---|---|---|---|---|---|---|---|
| Name    | Power management capabilities |    |    |    |    |    |   |   |   |   |   |   |   |   |   |   |
| Type    | RU                            | R  | R  | R  | R  | R  | R | R | R | R | R | R | R | R | R | R |
| Default | 0                             | 1  | 1  | 1  | 1  | 1  | 1 | 0 | 0 | 0 | 0 | 0 | 0 | 0 | 1 | 0 |

Register: **Power management capabilities**  
 Offset: 46h  
 Type: Read/Update, Read-only  
 Default: 7E02h

**Table 7–12. Power Management Capabilities Register Description**

| BIT   | FIELD NAME  | TYPE | DESCRIPTION   |
|-------|-------------|------|---|
| 15    | PME_D3COLD  | RU   | $\overline{\text{PME}}$ support from D3 <sub>cold</sub> . This bit can be set to 1 or cleared to 0 via bit 4 (D3_COLD) in the general control register at offset 4Ch in the PCI configuration space (see Section 7.21). When this bit is set to 1, it indicates that the PCI6x20 device is capable of generating a $\overline{\text{PME}}$ wake event from D3 <sub>cold</sub> . This bit state is dependent upon the PCI6x20 V <sub>AUX</sub> implementation and may be configured by using bit 4 (D3_COLD) in the general control register (see Section 7.21). |
| 14–11 | PME_SUPPORT | R    | $\overline{\text{PME}}$ support. This 4-bit field indicates the power states from which the flash media interface may assert $\overline{\text{PME}}$ . This field returns a value of 1111b by default, indicating that $\overline{\text{PME}}$ may be asserted from the D3 <sub>hot</sub> , D2, D1, and D0 power states.  |
| 10    | D2_SUPPORT  | R    | D2 support. Bit 10 is hardwired to 1, indicating that the flash media controller supports the D2 power state.   |
| 9     | D1_SUPPORT  | R    | D1 support. Bit 9 is hardwired to 1, indicating that the flash media controller supports the D1 power state.  |
| 8–6   | AUX_CURRENT | R    | Auxiliary current. This 3-bit field reports the 3.3-V <sub>AUX</sub> auxiliary current requirements. When bit 15 (PME_D3COLD) is cleared, this field returns 000b; otherwise, it returns 001b.<br>000b = Self-powered<br>001b = 55 mA (3.3-V <sub>AUX</sub> maximum current required)   |
| 5     | DSI         | R    | Device-specific initialization. This bit returns 0 when read, indicating that the flash media controller does not require special initialization beyond the standard PCI configuration header before a generic class driver is able to use it.  |
| 4     | RSVD        | R    | Reserved. Bit 4 returns 0 when read.  |
| 3     | PME_CLK     | R    | $\overline{\text{PME}}$ clock. This bit returns 0 when read, indicating that the PCI clock is not required for the flash media controller to generate $\overline{\text{PME}}$ .   |
| 2–0   | PM_VERSION  | R    | Power-management version. This field returns 010b when read, indicating that the flash media controller is compatible with the registers described in the <i>PCI Bus Power Management Interface Specification</i> (Revision 1.1).   |

## 7.18 Power Management Control and Status Register

The power management control and status register implements the control and status of the flash media controller. This register is not affected by the internally generated reset caused by the transition from the D3<sub>hot</sub> to D0 state. See Table 7–13 for a complete description of the register contents.

| Bit            | 15                                  | 14 | 13 | 12 | 11 | 10 | 9 | 8  | 7 | 6 | 5 | 4 | 3 | 2 | 1  | 0  |
|----------------|-------------------------------------|----|----|----|----|----|---|----|---|---|---|---|---|---|----|----|
| <b>Name</b>    | Power management control and status |    |    |    |    |    |   |    |   |   |   |   |   |   |    |    |
| <b>Type</b>    | RCU                                 | R  | R  | R  | R  | R  | R | RW | R | R | R | R | R | R | RW | RW |
| <b>Default</b> | 0                                   | 0  | 0  | 0  | 0  | 0  | 0 | 0  | 0 | 0 | 0 | 0 | 0 | 0 | 0  | 0  |

Register: **Power management control and status**  
 Offset: 48h  
 Type: Read/Clear, Read/Write, Read-only  
 Default: 0000h

**Table 7–13. Power Management Control and Status Register Description**

| BIT   | FIELD NAME  | TYPE | DESCRIPTION  |
|-------|-------------|------|--|
| 15 ‡  | PME_STAT    | RCU  | $\overline{\text{PME}}$ status. This bit defaults to 0.  |
| 14–13 | DATA_SCALE  | R    | This field returns 0s, because the data register is not implemented.   |
| 12–9  | DATA_SELECT | R    | This field returns 0s, because the data register is not implemented.   |
| 8 ‡   | PME_EN      | RW   | $\overline{\text{PME}}$ enable. Enables $\overline{\text{PME}}$ signaling. Assertion is disabled.  |
| 7–2   | RSVD        | R    | Reserved. Bits 7–2 return 0s when read.  |
| 1–0 ‡ | PWR_STATE   | RW   | Power state. This 2-bit field determines the current power state and sets the flash media controller to a new power state. This field is encoded as follows:<br>00 = Current power state is D0.<br>01 = Current power state is D1.<br>10 = Current power state is D2.<br>11 = Current power state is D3 <sub>hot</sub> . |

‡ One or more bits in this register are cleared only by the assertion of  $\overline{\text{GRST}}$ .

## 7.19 Power Management Bridge Support Extension Register

The power management bridge support extension register provides extended power-management features not applicable to the flash media controller; thus, it is read-only and returns 0 when read.

| Bit            | 7   | 6 | 5 | 4 | 3 | 2 | 1 | 0 |
|----------------|---|---|---|---|---|---|---|---|
| <b>Name</b>    | Power management bridge support extension |   |   |   |   |   |   |   |
| <b>Type</b>    | R   | R | R | R | R | R | R | R |
| <b>Default</b> | 0   | 0 | 0 | 0 | 0 | 0 | 0 | 0 |

Register: **Power management bridge support extension**  
 Offset: 4Ah  
 Type: Read-only  
 Default: 00h

## 7.20 Power Management Data Register

The power management bridge support extension register provides extended power-management features not applicable to the flash media controller; thus, it is read-only and returns 0 when read.

| Bit     | 7                     | 6 | 5 | 4 | 3 | 2 | 1 | 0 |
|---------|-----------------------|---|---|---|---|---|---|---|
| Name    | Power management data |   |   |   |   |   |   |   |
| Type    | R                     | R | R | R | R | R | R | R |
| Default | 0                     | 0 | 0 | 0 | 0 | 0 | 0 | 0 |

Register: **Power management data**  
 Offset: 4Bh  
 Type: Read-only  
 Default: 00h

## 7.21 General Control Register

The general control register provides miscellaneous PCI-related configuration. See Table 7–14 for a complete description of the register contents.

| Bit     | 7               | 6 | 5 | 4  | 3  | 2  | 1  | 0  |
|---------|-----------------|---|---|----|----|----|----|----|
| Name    | General control |   |   |    |    |    |    |    |
| Type    | R               | R | R | RW | RW | RW | RW | RW |
| Default | 0               | 0 | 0 | 0  | 0  | 0  | 0  | 0  |

Register: **General control**  
 Offset: 4Ch  
 Type: Read/Write, Read-only  
 Default: 00h

**Table 7–14. General Control Register**

| BIT   | FIELD NAME | TYPE | DESCRIPTION  |
|-------|------------|------|--|
| 7     | RSVD       | R    | Reserved. Bit 7 returns 0 when read.   |
| 6–5 ‡ | INT_SEL    | RW   | Interrupt select. These bits are program the INTPIN register and set which interrupt output is used. This field is ignored if one of the USE_INTx terminals is asserted.<br>00 = $\overline{\text{INTA}}$<br>01 = $\overline{\text{INTB}}$<br>10 = $\overline{\text{INTC}}$<br>11 = $\overline{\text{INTD}}$ |
| 4 ‡   | D3_COLD    | RW   | D3 <sub>cold</sub> $\overline{\text{PME}}$ support. This bit sets and clears the D3 <sub>cold</sub> $\overline{\text{PME}}$ support bit in the power management capabilities register.   |
| 3–2 ‡ | RSVD       | R    | Reserved. Bits 3 and 2 return 0s when read.  |
| 1 ‡   | MMC_SD_DIS | RW   | MMC/SD disable. Setting this bit disables support for MMC/SD cards. The flash media controller reports a MMC/SD card as an unsupported card if this bit is set. If this bit is set, then all of the SD_SUPPORT bits in the socket enumeration register are 0.  |
| 0 ‡   | MS_DIS     | RW   | Memory Stick disable. Setting this bit disables support for Memory Stick cards. The flash media controller reports a Memory Stick card as an unsupported card if this bit is set. If this bit is set, then all of the MS_SUPPORT bits in the socket enumeration register are 0.                              |

‡ One or more bits in this register are cleared only by the assertion of  $\overline{\text{GRST}}$ .

## 7.22 Subsystem Access Register

The contents of the subsystem access register are aliased to the subsystem vendor ID and subsystem ID registers at PCI offsets 2Ch and 2Eh, respectively. See Table 7–15 for a complete description of the register contents.

|                |                  |           |           |           |           |           |           |           |           |           |           |           |           |           |           |           |
|----------------|------------------|-----------|-----------|-----------|-----------|-----------|-----------|-----------|-----------|-----------|-----------|-----------|-----------|-----------|-----------|-----------|
| <b>Bit</b>     | <b>31</b>        | <b>30</b> | <b>29</b> | <b>28</b> | <b>27</b> | <b>26</b> | <b>25</b> | <b>24</b> | <b>23</b> | <b>22</b> | <b>21</b> | <b>20</b> | <b>19</b> | <b>18</b> | <b>17</b> | <b>16</b> |
| <b>Name</b>    | Subsystem access |           |           |           |           |           |           |           |           |           |           |           |           |           |           |           |
| <b>Type</b>    | RW               | RW        | RW        | RW        | RW        | RW        | RW        | RW        | RW        | RW        | RW        | RW        | RW        | RW        | RW        | RW        |
| <b>Default</b> | 0                | 0         | 0         | 0         | 0         | 0         | 0         | 0         | 0         | 0         | 0         | 0         | 0         | 0         | 0         | 0         |
| <b>Bit</b>     | <b>15</b>        | <b>14</b> | <b>13</b> | <b>12</b> | <b>11</b> | <b>10</b> | <b>9</b>  | <b>8</b>  | <b>7</b>  | <b>6</b>  | <b>5</b>  | <b>4</b>  | <b>3</b>  | <b>2</b>  | <b>1</b>  | <b>0</b>  |
| <b>Name</b>    | Subsystem access |           |           |           |           |           |           |           |           |           |           |           |           |           |           |           |
| <b>Type</b>    | RW               | RW        | RW        | RW        | RW        | RW        | RW        | RW        | RW        | RW        | RW        | RW        | RW        | RW        | RW        | RW        |
| <b>Default</b> | 0                | 0         | 0         | 0         | 0         | 0         | 0         | 0         | 0         | 0         | 0         | 0         | 0         | 0         | 0         | 0         |

Register: **Subsystem access**  
 Offset: 50h  
 Type: Read/Write  
 Default: 0000 0000h

**Table 7–15. Subsystem Access Register Description**

| <b>BIT</b> | <b>FIELD NAME</b> | <b>TYPE</b> | <b>DESCRIPTION</b>   |
|------------|-------------------|-------------|--|
| 31–16      | SubsystemID       | RW          | Subsystem device ID. The value written to this field is aliased to the subsystem ID register at PCI offset 2Eh.        |
| 15–0       | SubsystemVendorID | RW          | Subsystem vendor ID. The value written to this field is aliased to the subsystem vendor ID register at PCI offset 2Ch. |

## 7.23 Diagnostic Register

This register programs the M and N inputs to the PLL and enables the diagnostic modes. The default values for M and N in this register set the PLL output to be 80 MHz, which is divided to get the 40 MHz and 20 MHz needed by the flash media cores. See Table 7–16 for a complete description of the register contents. All bits in this register are reset by  $\overline{GRST}$  only.

|                |            |           |           |           |           |           |           |           |           |           |           |           |           |           |           |           |
|----------------|------------|-----------|-----------|-----------|-----------|-----------|-----------|-----------|-----------|-----------|-----------|-----------|-----------|-----------|-----------|-----------|
| <b>Bit</b>     | <b>31</b>  | <b>30</b> | <b>29</b> | <b>28</b> | <b>27</b> | <b>26</b> | <b>25</b> | <b>24</b> | <b>23</b> | <b>22</b> | <b>21</b> | <b>20</b> | <b>19</b> | <b>18</b> | <b>17</b> | <b>16</b> |
| <b>Name</b>    | Diagnostic |           |           |           |           |           |           |           |           |           |           |           |           |           |           |           |
| <b>Type</b>    | R          | R         | R         | R         | R         | R         | R         | R         | R         | R         | R         | R         | R         | R         | R         | R/W       |
| <b>Default</b> | 0          | 0         | 0         | 0         | 0         | 0         | 0         | 0         | 0         | 0         | 0         | 0         | 0         | 0         | 0         | 0         |
| <b>Bit</b>     | <b>15</b>  | <b>14</b> | <b>13</b> | <b>12</b> | <b>11</b> | <b>10</b> | <b>9</b>  | <b>8</b>  | <b>7</b>  | <b>6</b>  | <b>5</b>  | <b>4</b>  | <b>3</b>  | <b>2</b>  | <b>1</b>  | <b>0</b>  |
| <b>Name</b>    | Diagnostic |           |           |           |           |           |           |           |           |           |           |           |           |           |           |           |
| <b>Type</b>    | R          | R         | R         | R         | R         | R         | R         | R/W       | R         | R         | R         | RW        | RW        | RW        | RW        | RW        |
| <b>Default</b> | 0          | 0         | 0         | 0         | 0         | 0         | 1         | 1         | 0         | 0         | 0         | 0         | 0         | 1         | 0         | 1         |

Register: **Diagnostic**  
 Type: Read-only, Read/Write  
 Offset: 54h  
 Default: 0000 0305h

**Table 7–16. Diagnostic Register Description**

| <b>BIT</b> | <b>SIGNAL</b> | <b>TYPE</b> | <b>FUNCTION</b>  |
|------------|---------------|-------------|--|
| 31–17      | TBD_CTRL      | R           | PLL control bits. These bits are reserved for PLL control and test bits.   |
| 16         | DIAGNOSTIC    | RW          | Diagnostic test bit. This test bit shortens the PLL clock CLK_VALID time and shortens the card detect debounce times for simulation and TDL. |
| 15–11      | RSVD          | R           | Reserved. Bits 15–11 return 0s when read.  |
| 10–8       | PLL_N         | RW          | PLL_N input. The default value of this field is 03h.   |
| 7–5        | RSVD          | R           | Reserved. Bits 7–5 return 0s when read.  |
| 4–0        | PLL_M         | RW          | PLL_M input. The default value of this field is 05h.   |



## 8 Electrical Characteristics

### 8.1 Absolute Maximum Ratings Over Operating Temperature Ranges†

|  |                                   |
|--|-----------------------------------|
| Supply voltage range, VR_PORT .....  | -0.2 V to 2.2 V                   |
| ANALOGV <sub>CC</sub> .....  | -0.3 V to 4 V                     |
| V <sub>CC</sub> .....  | -0.3 V to 4 V                     |
| PLL <sub>VCC</sub> .....   | -0.3 V to 4 V                     |
| V <sub>CCCB</sub> .....  | -0.5 V to 5.5 V                   |
| V <sub>CCP</sub> .....   | -0.5 V to 5.5 V                   |
| Clamping voltage range, V <sub>CCP</sub> and V <sub>CCCB</sub> .....   | -0.5 V to 6 V                     |
| Input voltage range, V <sub>I</sub> : PCI, CardBus, PHY, miscellaneous .....                                       | -0.5 V to V <sub>CC</sub> + 0.5 V |
| Output voltage range, V <sub>O</sub> : PCI, CardBus, PHY, miscellaneous .....                                      | -0.5 V to V <sub>CC</sub> + 0.5 V |
| Input clamp current, I <sub>IK</sub> (V <sub>I</sub> < 0 or V <sub>I</sub> > V <sub>CC</sub> ) (see Note 1) .....  | ±20 mA                            |
| Output clamp current, I <sub>OK</sub> (V <sub>O</sub> < 0 or V <sub>O</sub> > V <sub>CC</sub> ) (see Note 2) ..... | ±20 mA                            |
| Operating free-air temperature, T <sub>A</sub> .....   | 0°C to 70°C                       |
| Storage temperature range, T <sub>stg</sub> .....  | -65°C to 150°C                    |
| Virtual junction temperature, T <sub>J</sub> .....   | 150°C                             |

† Stresses beyond those listed under absolute maximum ratings may cause permanent damage to the device. These are stress ratings only and functional operation of the device at these or any other conditions beyond those indicated under recommended operating conditions is not implied. Exposure to absolute-maximum-rated conditions for extended periods may affect device reliability.

- NOTES:
1. Applies for external input and bidirectional buffers. V<sub>I</sub> > V<sub>CC</sub> does not apply to fail-safe terminals. PCI terminals and miscellaneous terminals are measured with respect to V<sub>CCP</sub> instead of V<sub>CC</sub>. PC Card terminals are measured with respect to CardBus V<sub>CC</sub>. The limit specified applies for a dc condition.
  2. Applies for external output and bidirectional buffers. V<sub>O</sub> > V<sub>CC</sub> does not apply to fail-safe terminals. PCI terminals and miscellaneous terminals are measured with respect to V<sub>CCP</sub> instead of V<sub>CC</sub>. PC Card terminals are measured with respect to CardBus V<sub>CC</sub>. The limit specified applies for a dc condition.

### 8.2 Recommended Operating Conditions (see Note 3)

|  | OPERATION | MIN  | NOM | MAX  | UNIT |
|--|-----------|------|-----|------|------|
| VR_PORT (see Table 2-4 for description)                  | 1.8 V     | 1.6  | 1.8 | 2    | V    |
| ANALOGV <sub>CC</sub>                                    | 3.3 V     | 3    | 3.3 | 3.6  | V    |
| V <sub>CC</sub>  | 3.3 V     | 3    | 3.3 | 3.6  | V    |
| PLL <sub>VCC</sub>                                       | 3.3 V     | 3    | 3.3 | 3.6  | V    |
| V <sub>CCP</sub> PCI and miscellaneous I/O clamp voltage | 3.3 V     | 3    | 3.3 | 3.6  | V    |
|  | 5 V       | 4.75 | 5   | 5.25 |      |
| V <sub>CCCB</sub> PC Card I/O clamp voltage              | 3.3 V     | 3    | 3.3 | 3.6  | V    |
|  | 5 V       | 4.75 | 5   | 5.25 |      |

NOTE 3: Unused terminals (input or I/O) must be held high or low to prevent them from floating.

## Recommended Operating Conditions (continued)

|                            |                                     | OPERATION                              | MIN                 | NOM      | MAX                 | UNIT               |     |    |
|----------------------------|-------------------------------------|--|---------------------|----------|---------------------|--------------------|-----|----|
| $V_{IH}^{\dagger}$         | PCI                                 | 3.3 V                                  | 0.5 $V_{CCP}$       |          | $V_{CCP}$           | V                  |     |    |
|                            |                                     | 5 V                                    | 2                   |          | $V_{CCP}$           |                    |     |    |
|                            | PC Card                             | 3.3 V CardBus                          | 0.475 $V_{CC(A/B)}$ |          | $V_{CC(A/B)}$       | V                  |     |    |
|                            |                                     | 3.3 V 16-bit                           | 2                   |          | $V_{CC(A/B)}$       | V                  |     |    |
|                            |                                     | 5 V 16-bit                             | 2.4                 |          | $V_{CC(A/B)}$       | V                  |     |    |
|                            | PC(0–2)                             |  | 0.7 $V_{CC}$        |          | $V_{CC}$            | V                  |     |    |
| Miscellaneous <sup>‡</sup> |                                     | 2                                      |                     | $V_{CC}$ | V                   |                    |     |    |
| $V_{IL}^{\dagger}$         | PCI                                 | 3.3 V                                  | 0                   |          | 0.3 $V_{CCP}$       | V                  |     |    |
|                            |                                     | 5 V                                    | 0                   |          | 0.8                 |                    |     |    |
|                            | PC Card                             | 3.3 V CardBus                          | 0                   |          | 0.325 $V_{CC(A/B)}$ | V                  |     |    |
|                            |                                     | 3.3 V 16-bit                           | 0                   |          | 0.8                 | V                  |     |    |
|                            |                                     | 5 V 16-bit                             | 0                   |          | 0.8                 | V                  |     |    |
|                            | PC(0–2)                             |  | 0                   |          | 0.2 $V_{CC}$        | V                  |     |    |
| Miscellaneous <sup>‡</sup> |                                     | 0                                      |                     | 0.8      | V                   |                    |     |    |
| $V_I$                      | PCI                                 |  | 0                   |          | $V_{CCP}$           | V                  |     |    |
|                            | PC Card                             |  | 0                   |          | $V_{CCCB}$          |                    |     |    |
|                            | Miscellaneous <sup>‡</sup>          |  | 0                   |          | $V_{CC}$            |                    |     |    |
| $V_{O}^{\S}$               | PCI                                 |  | 0                   |          | $V_{CC}$            | V                  |     |    |
|                            | PC Card                             |  | 0                   |          | $V_{CC}$            |                    |     |    |
|                            | Miscellaneous <sup>‡</sup>          |  | 0                   |          | $V_{CC}$            |                    |     |    |
| $t_t$                      | PCI and PC Card                     |  | 1                   |          | 4                   | ns                 |     |    |
|                            | Miscellaneous <sup>‡</sup>          |  | 0                   |          | 6                   |                    |     |    |
| $I_O$                      | Output current                      | TPBIAS outputs                         |                     |          | –5.6                | 1.3                | mA  |    |
| $V_{ID}$                   | Differential input voltage          | Cable inputs during data reception     |                     |          | 118                 | 260                | mV  |    |
|                            |                                     | Cable inputs during arbitration        |                     |          | 168                 | 265                |     |    |
| $V_{IC}$                   | Common-mode input voltage           | TPB cable inputs, source power node    |                     |          | 0.4706              | 2.515              | V   |    |
|                            |                                     | TPB cable inputs, nonsource power node |                     |          | 0.4706              | 2.015 <sup>¶</sup> |     |    |
| $t_{PU}$                   | Power up reset time                 | GRST input                             |                     |          | 2                   |                    | ms  |    |
|                            | Receive input jitter                | TPA, TPB cable inputs                  | S100 operation      |          |                     | ±1.08              | ns  |    |
|                            |                                     |  | S200 operation      |          |                     | ±0.5               |     |    |
|                            |                                     |  | S400 operation      |          |                     | ±0.315             |     |    |
|                            | Receive input skew                  | Between TPA and TPB cable inputs       | S100 operation      |          |                     | ±0.8               | ns  |    |
|                            |                                     |  | S200 operation      |          |                     | ±0.55              |     |    |
|                            |                                     |  | S400 operation      |          |                     | ±0.5               |     |    |
| $T_A$                      | Operating ambient temperature range |  |                     |          | 0                   | 25                 | 70  | °C |
| $T_{J\#}$                  | Virtual junction temperature        |  |                     |          | 0                   | 25                 | 115 | °C |

<sup>†</sup> Applies to external inputs and bidirectional buffers without hysteresis

<sup>‡</sup> Miscellaneous terminals are 1, 2, 12, 17, 111, 112, 125, 167, 181, and 187 for the PDV packaged device and B10, C09, D01, E03, F12, G03, H02, L17, P17, and P18 for the GHK packaged device (CNA, SCL, SDA, SUSPEND, GRST, CDx, PHY\_TEST\_MA, and VSx terminals).

<sup>§</sup> Applies to external output buffers

<sup>¶</sup> For a node that does not source power, see Section 4.2.2.2 in IEEE Std 1394a–2000.

<sup>#</sup> These junction temperatures reflect simulation conditions. The customer is responsible for verifying junction temperature.

### 8.3 Electrical Characteristics Over Recommended Operating Conditions (unless otherwise noted)

| PARAMETER  | TERMINALS        | OPERATION                                     | TEST CONDITIONS                               | MIN                 | MAX | UNIT |
|--|------------------|---|---|---------------------|-----|------|
| V <sub>OH</sub> High-level output voltage                  | PCI              | 3.3 V   | I <sub>OH</sub> = -0.5 mA                     | 0.9 V <sub>CC</sub> |     | V    |
|  |                  | 5 V   | I <sub>OH</sub> = -2 mA                       | 2.4                 |     |      |
|  | PC Card          | 3.3 V CardBus                                 | I <sub>OH</sub> = -0.15 mA                    | 0.9 V <sub>CC</sub> |     | V    |
|  |                  | 3.3 V 16-bit                                  | I <sub>OH</sub> = -0.15 mA                    | 2.4                 |     |      |
|  |                  | 5 V 16-bit                                    | I <sub>OH</sub> = -0.15 mA                    | 2.8                 |     |      |
| Miscellaneous <sup>§</sup>                                 |                  | I <sub>OH</sub> = -4 mA                       | V <sub>CC</sub> -0.6                          |                     |     |      |
| V <sub>OL</sub> Low-level output voltage                   | PCI              | 3.3 V   | I <sub>OL</sub> = 1.5 mA                      | 0.1 V <sub>CC</sub> |     | V    |
|  |                  | 5 V   | I <sub>OL</sub> = 6 mA                        | 0.55                |     |      |
|  | PC Card          | 3.3 V CardBus                                 | I <sub>OL</sub> = 0.7 mA                      | 0.1 V <sub>CC</sub> |     |      |
|  |                  | 3.3 V 16-bit                                  | I <sub>OL</sub> = 0.7 mA                      | 0.4                 |     |      |
|  |                  | 5 V 16-bit                                    | I <sub>OL</sub> = 0.7 mA                      | 0.55                |     |      |
| Miscellaneous <sup>§</sup>                                 |                  | I <sub>OL</sub> = 4 mA                        | 0.5   |                     |     |      |
| I <sub>OZ</sub> 3-state output high-impedance              | Output terminals | 3.6 V   | V <sub>O</sub> = V <sub>CC</sub> or GND       |                     | ±20 | μA   |
| I <sub>OZL</sub> High-impedance, low-level output current  | Output terminals | 3.6 V   | V <sub>I</sub> = V <sub>CC</sub>              |                     | -1  | μA   |
|  |                  | 5.25 V  | V <sub>I</sub> = V <sub>CC</sub>              |                     | -1  |      |
| I <sub>OZH</sub> High-impedance, high-level output current | Output terminals | 3.6 V   | V <sub>I</sub> = V <sub>CC</sub> <sup>†</sup> |                     | 10  | μA   |
|  |                  | 5.25 V  | V <sub>I</sub> = V <sub>CC</sub> <sup>†</sup> |                     | 25  |      |
| I <sub>IL</sub> Low-level input current                    | Input terminals  | 3.6 V   | V <sub>I</sub> = GND                          |                     | ±20 | μA   |
|  | I/O terminals    | 3.6 V   | V <sub>I</sub> = GND                          |                     | ±20 |      |
| I <sub>IH</sub> High-level input current                   | PCI              | 3.6 V   | V <sub>I</sub> = V <sub>CC</sub> <sup>‡</sup> |                     | ±20 | μA   |
|  | Others           | 3.6 V   | V <sub>I</sub> = V <sub>CC</sub> <sup>‡</sup> |                     | ±20 |      |
|  | Input terminals  | 3.6 V   | V <sub>I</sub> = V <sub>CC</sub> <sup>‡</sup> |                     | 10  |      |
|  |                  | 5.25 V  | V <sub>I</sub> = V <sub>CC</sub> <sup>‡</sup> |                     | 20  |      |
|  | I/O terminals    | 3.6 V   | V <sub>I</sub> = V <sub>CC</sub> <sup>‡</sup> |                     | 10  |      |
| 5.25 V   |                  | V <sub>I</sub> = V <sub>CC</sub> <sup>‡</sup> |   | 25                  |     |      |

<sup>†</sup> For PCI and miscellaneous terminals, V<sub>I</sub> = V<sub>CCP</sub>. For PC Card terminals, V<sub>I</sub> = V<sub>CC(A/B)</sub>.

<sup>‡</sup> For I/O terminals, input leakage (I<sub>IL</sub> and I<sub>IH</sub>) includes I<sub>OZ</sub> leakage of the disabled output.

<sup>§</sup> Miscellaneous terminals are 1, 2, 12, 17, 111, 112, 125, 167, 181, and 187 for the PDV packaged device and B10, C09, D01, E03, F12, G03, H02, L17, P17, and P18 for the GHK packaged device (CNA, SCL, SDA, SUSPEND, GRST, CDx, PHY\_TEST\_MA, and VSx terminals).

### 8.4 Electrical Characteristics Over Recommended Ranges of Operating Conditions (unless otherwise noted)

#### 8.4.1 Device

| PARAMETER  | TEST CONDITION                  | MIN   | MAX   | UNIT |
|--|---------------------------------|-------|-------|------|
| V <sub>TH</sub> Power status threshold, CPS input <sup>†</sup> | 400-kΩ resistor <sup>†</sup>    | 4.7   | 7.5   | V    |
| V <sub>O</sub> TPBIAS output voltage                           | At rated I <sub>O</sub> current | 1.665 | 2.015 | V    |
| I <sub>I</sub> Input current (PC0–PC2 inputs)                  | V <sub>CC</sub> = 3.6 V         |       | 5     | μA   |

<sup>†</sup> Measured at cable power side of resistor.

## 8.4.2 Driver

| PARAMETER          |   | TEST CONDITION                       | MIN                | MAX                | UNIT |
|--------------------|---|--------------------------------------|--------------------|--------------------|------|
| V <sub>OD</sub>    | Differential output voltage                       | 56 Ω, See Figure 8-1                 | 172                | 265                | mV   |
| I <sub>DIFF</sub>  | Driver difference current, TPA+, TPA-, TPB+, TPB- | Drivers enabled, speed signaling off | -1.05 <sup>†</sup> | 1.05 <sup>†</sup>  | mA   |
| I <sub>SP200</sub> | Common-mode speed signaling current, TPB+, TPB-   | S200 speed signaling enabled         | -4.84 <sup>‡</sup> | -2.53 <sup>‡</sup> | mA   |
| I <sub>SP400</sub> | Common-mode speed signaling current, TPB+, TPB-   | S400 speed signaling enabled         | -12.4 <sup>‡</sup> | -8.10 <sup>‡</sup> | mA   |
| V <sub>OFF</sub>   | Off state differential voltage                    | Drivers disabled, See Figure 8-1     |                    | 20                 | mV   |

<sup>†</sup>Limits defined as algebraic sum of TPA+ and TPA- driver currents. Limits also apply to TPB+ and TPB- algebraic sum of driver currents.

<sup>‡</sup>Limits defined as absolute limit of each of TPB+ and TPB- driver currents.

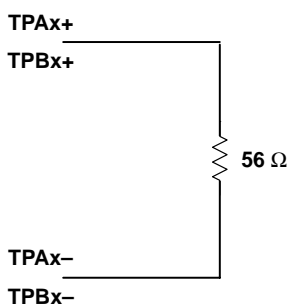

Figure 8-1. Test Load Diagram

## 8.4.3 Receiver

| PARAMETER             |   | TEST CONDITION                                   | MIN  | TYP | MAX | UNIT |
|-----------------------|---|--|------|-----|-----|------|
| Z <sub>ID</sub>       | Differential impedance                            | Drivers disabled                                 | 4    | 7   |     | kΩ   |
|                       |   |  |      |     | 4   | pF   |
| Z <sub>IC</sub>       | Common-mode impedance                             | Drivers disabled                                 | 20   |     |     | kΩ   |
|                       |   |  |      |     | 24  | pF   |
| V <sub>TH-R</sub>     | Receiver input threshold voltage                  | Drivers disabled                                 | -30  |     | 30  | mV   |
| V <sub>TH-CB</sub>    | Cable bias detect threshold, TPBx cable inputs    | Drivers disabled                                 | 0.6  |     | 1.0 | V    |
| V <sub>TH+</sub>      | Positive arbitration comparator threshold voltage | Drivers disabled                                 | 89   |     | 168 | mV   |
| V <sub>TH-</sub>      | Negative arbitration comparator threshold voltage | Drivers disabled                                 | -168 |     | -89 | mV   |
| V <sub>TH-SP200</sub> | Speed signal threshold                            | TPBIAS-TPA common mode voltage, drivers disabled | 49   |     | 131 | mV   |
| V <sub>TH-SP400</sub> | Speed signal threshold                            |  | 314  |     | 396 | mV   |

## 8.5 PCI Clock/Reset Timing Requirements Over Recommended Ranges of Supply Voltage and Operating Free-Air Temperature

| PARAMETER                       |  | ALTERNATE SYMBOL     | TEST CONDITIONS | MIN | MAX | UNIT |
|---------------------------------|--|----------------------|-----------------|-----|-----|------|
| t <sub>c</sub>                  | Cycle time, PCLK                       | t <sub>cyc</sub>     |                 | 30  |     | ns   |
| t <sub>w(H)</sub>               | Pulse duration (width), PCLK high      | t <sub>high</sub>    |                 | 11  |     | ns   |
| t <sub>w(L)</sub>               | Pulse duration (width), PCLK low       | t <sub>low</sub>     |                 | 11  |     | ns   |
| t <sub>r</sub> , t <sub>f</sub> | Slew rate, PCLK                        | Δv/Δt                |                 | 1   | 4   | V/ns |
| t <sub>w</sub>                  | Pulse duration (width), GRST           | t <sub>rst</sub>     |                 | 1   |     | ms   |
| t <sub>su</sub>                 | Setup time, PCLK active at end of PRST | t <sub>rst-clk</sub> |                 | 100 |     | μs   |

## 8.6 Switching Characteristics for PHY Port Interface

| PARAMETER        |                                     | TEST CONDITIONS               | MIN | TYP | MAX   | UNIT |
|------------------|-------------------------------------|-------------------------------|-----|-----|-------|------|
| Jitter, transmit |                                     | Between TPA and TPB           |     |     | ±0.15 | ns   |
| Skew, transmit   |                                     | Between TPA and TPB           |     |     | ±0.10 | ns   |
| $t_r$            | TP differential rise time, transmit | 10% to 90%, at 1394 connector | 0.5 |     | 1.2   | ns   |
| $t_f$            | TP differential fall time, transmit | 90% to 10%, at 1394 connector | 0.5 |     | 1.2   | ns   |

## 8.7 Operating, Timing, and Switching Characteristics of XI

| PARAMETER                       |                          | MIN           | TYP | MAX | UNIT              |
|---------------------------------|--------------------------|---------------|-----|-----|-------------------|
| $V_{DD}$                        |                          | 3.0           | 3.3 | 3.6 | V (PLL $V_{CC}$ ) |
| $V_{IH}$                        | High-level input voltage | 0.63 $V_{CC}$ |     |     | V                 |
| $V_{IL}$                        | Low-level input voltage  | 0.33 $V_{CC}$ |     |     | V                 |
| Input clock frequency           |                          | 24.576        |     |     | MHz               |
| Input clock frequency tolerance |                          | <100          |     |     | PPM               |
| Input slew rate                 |                          | 0.2           |     | 4   | V/ns              |
| Input clock duty cycle          |                          | 40%           |     | 60% |                   |

## 8.8 PCI Timing Requirements Over Recommended Ranges of Supply Voltage and Operating Free-Air Temperature

This data manual uses the following conventions to describe time (  $t$  ) intervals. The format is  $t_A$ , where *subscript A* indicates the type of dynamic parameter being represented. One of the following is used:  $t_{pd}$  = propagation delay time,  $t_d$  ( $t_{en}$ ,  $t_{dis}$ ) = delay time,  $t_{su}$  = setup time, and  $t_h$  = hold time.

| PARAMETER |   | ALTERNATE SYMBOL | TEST CONDITIONS              | MIN | MAX | UNIT |
|-----------|---|------------------|------------------------------|-----|-----|------|
| $t_{pd}$  | PCLK-to-shared signal valid delay time                      | $t_{val}$        | $C_L = 50$ pF,<br>See Note 4 |     | 11  | ns   |
|           | PCLK-to-shared signal invalid delay time                    | $t_{inv}$        |                              | 2   |     |      |
| $t_{en}$  | Enable time, high impedance-to-active delay time from PCLK  | $t_{on}$         |                              | 2   |     | ns   |
| $t_{dis}$ | Disable time, active-to-high impedance delay time from PCLK | $t_{off}$        |                              |     | 28  | ns   |
| $t_{su}$  | Setup time before PCLK valid                                | $t_{su}$         |                              | 7   |     | ns   |
| $t_h$     | Hold time after PCLK high                                   | $t_h$            |                              | 0   |     | ns   |

NOTE 4: PCI shared signals are AD31–AD0, C/BE3–C/BE0, FRAME, TRDY, IRDY, STOP, IDSEL, DEVSEL, and PAR.



## 9 Mechanical Information

The PCI6x20 is packaged in a 288-ball GHK BGA package. The following shows the mechanical dimensions for the GHK package.

### GHK (S-PBGA-N288)

### PLASTIC BALL GRID ARRAY

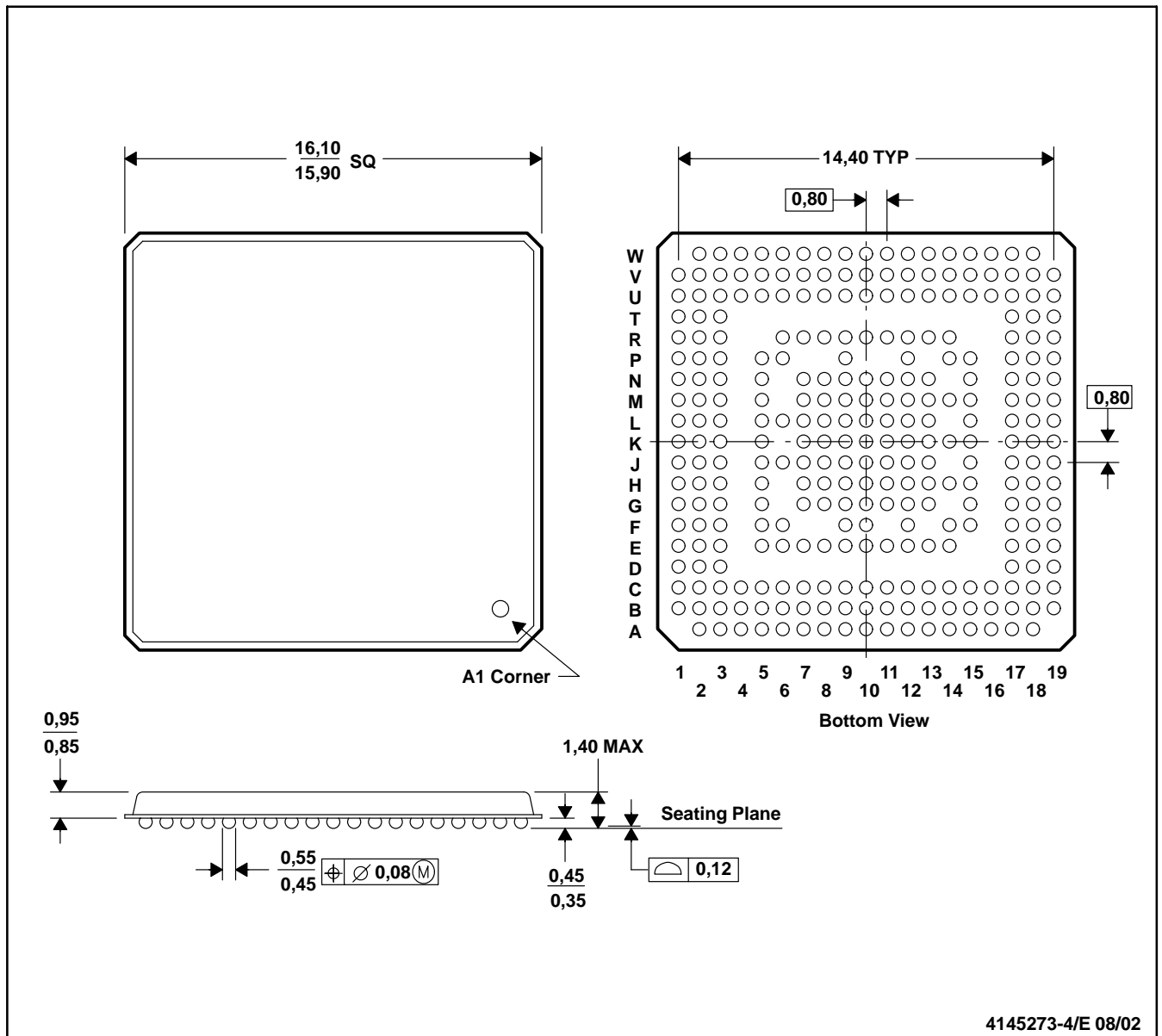

4145273-4/E 08/02

- NOTES: A. All linear dimensions are in millimeters.  
 B. This drawing is subject to change without notice.  
 C. MicroStar BGA™ configuration.

MicroStar BGA is a trademark of Texas Instruments.



GHK (S-PBGA-N288)

PLASTIC BALL GRID ARRAY

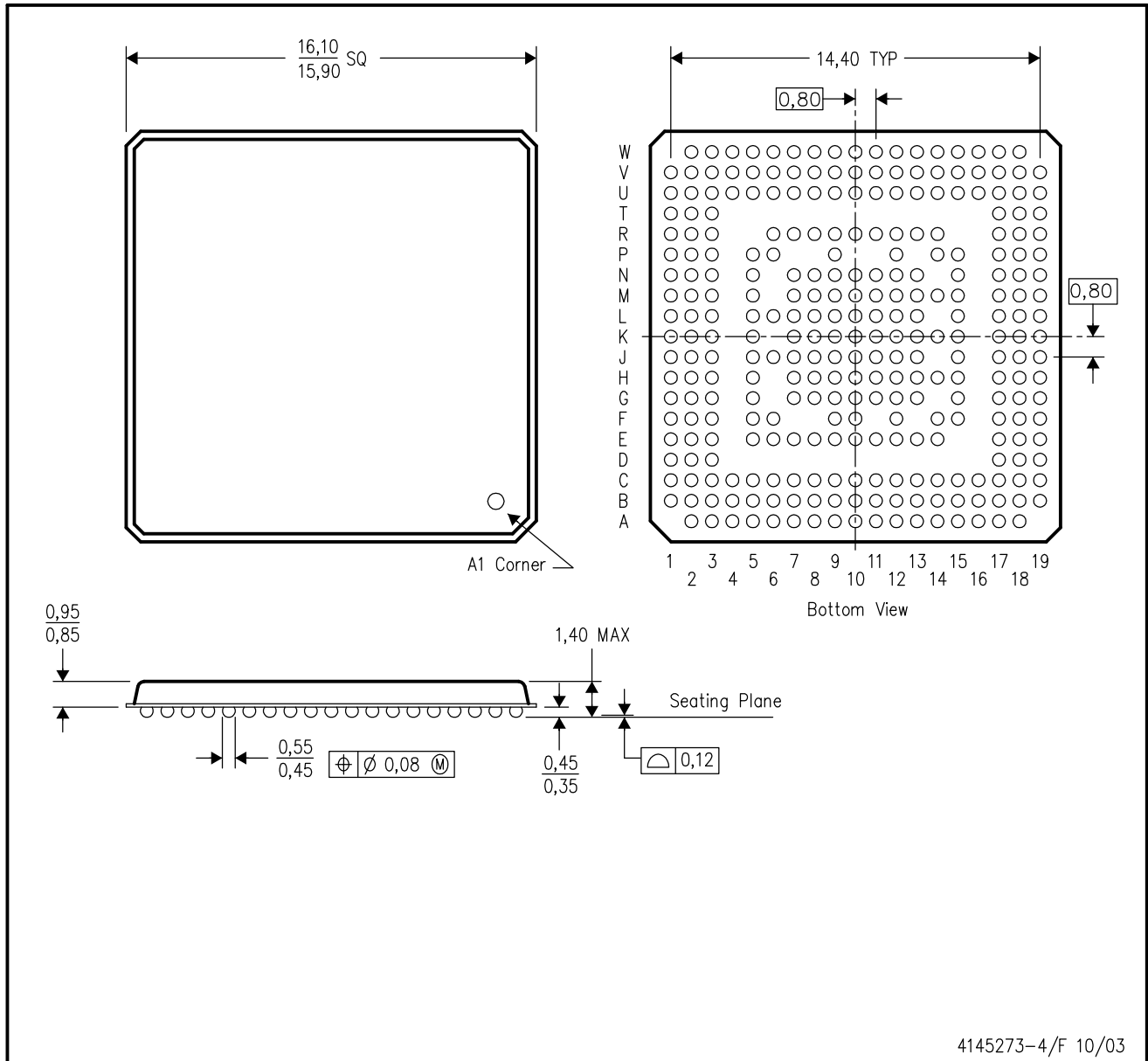

- NOTES:
- A. All linear dimensions are in millimeters.
  - B. This drawing is subject to change without notice.
  - C. MicroStar BGA™ configuration.

MicroStar BGA is a trademark of Texas Instruments.

ZHK (S-PBGA-N288)

PLASTIC BALL GRID ARRAY

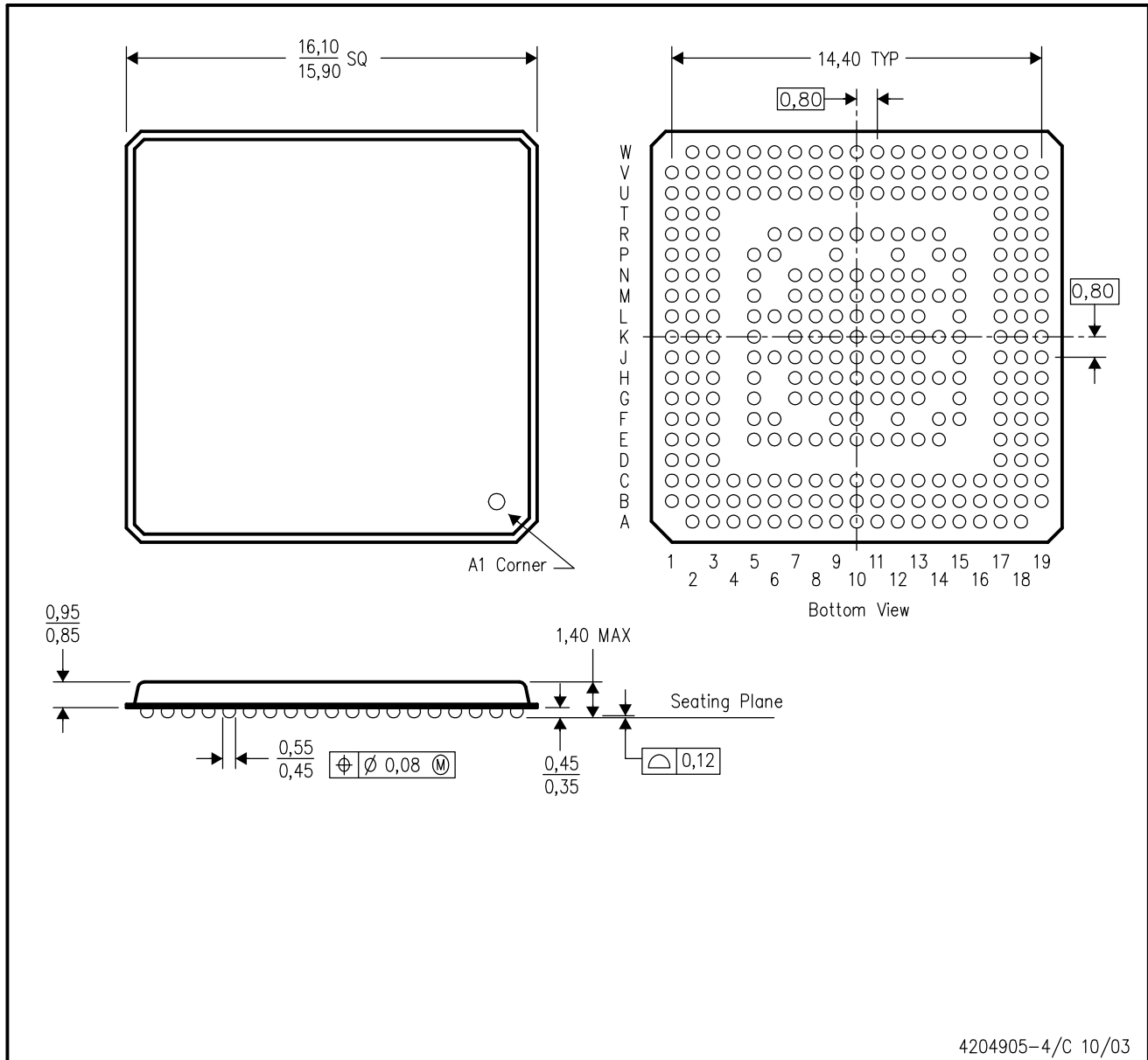

- NOTES:
- A. All linear dimensions are in millimeters.
  - B. This drawing is subject to change without notice.
  - C. MicroStar BGA™ configuration
  - D. This package is lead-free.

MicroStar BGA is a trademark of Texas Instruments.

## Looking for pricing, stock, or lifecycle information?

Click below to explore more details on WIN SOURCE:

 [View PCI6420GHK](#) on WIN SOURCE

 [Texas Instruments](#) Information

## Optimize Your Supply Chain with WIN SOURCE Solutions

-  Global Sourcing Solution
-  Obsolete Management
-  Cost Control Management
-  Shortage Management
-  Alternative Solution
-  Excess Inventory Management