

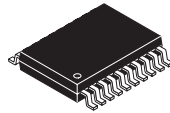

# THE DATASHEET OF PCM1606EG





## 24-BIT, 192-kHz SAMPLING, 6-CHANNEL, ENHANCED MULTILEVEL, DELTA-SIGMA DIGITAL-TO-ANALOG CONVERTER

### FEATURES

- 24-Bit Resolution
- Analog Performance:
  - Dynamic Range: 103 dB, Typical
  - SNR: 103 dB, Typical
  - THD+N: 0.004%, Typical
  - Full-Scale Output: 3.1 Vp-p, Typical
- 8× Oversampling Interpolation Filter:
  - Stopband Attenuation: –55 dB
  - Passband Ripple: ±0.03 dB
- Sampling Frequency:
  - 5 kHz to 200 kHz (Channels 1 and 2)
  - 5 kHz to 100 kHz (Channels 3, 4, 5, and 6)
- Accepts 16- and 24-Bit Audio Data
- Data Formats: Standard, I<sup>2</sup>S, and Left-Justified, TDM
- System Clock: 128 f<sub>S</sub>, 192 f<sub>S</sub>, 256 f<sub>S</sub>, 384 f<sub>S</sub>, 512 f<sub>S</sub>, or 768 f<sub>S</sub>
- Digital De-Emphasis for 32 kHz, 44.1 kHz, 48 kHz
- Power Supply: 5-V Single Supply
- 20-Lead SSOP Package

### APPLICATIONS

- Integrated A/V Receivers
- DVD Movie and Audio Players
- HDTV Receivers
- Car Audio Systems
- DVD Add-On Cards for High-End PCs
- Digital Audio Workstations
- Other Multichannel Audio Systems

### DESCRIPTION

The PCM1606 is a CMOS monolithic integrated circuit that features six 24-bit audio digital-to-analog converters and support circuitry in a small 20-lead SSOP package. The digital-to-analog converters utilize Texas Instruments' enhanced multilevel, delta-sigma architecture, which employs 2<sup>nd</sup>-order noise shaping and 8-level amplitude quantization to achieve excellent signal-to-noise performance and a high tolerance to clock jitter.

The PCM1606 accepts industry-standard audio data formats with 16- to 24-bit audio data. Sampling rates up to 200 kHz are supported.

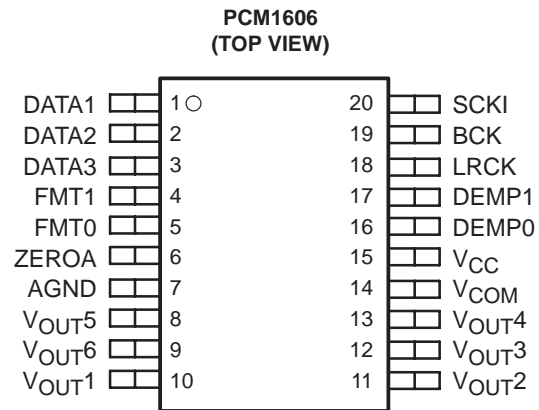

Please be aware that an important notice concerning availability, standard warranty, and use in critical applications of Texas Instruments semiconductor products and disclaimers thereto appears at the end of this data sheet.

PRODUCTION DATA information is current as of publication date. Products conform to specifications per the terms of Texas Instruments standard warranty. Production processing does not necessarily include testing of all parameters.

Copyright © 2002, Texas Instruments Incorporated

## PACKAGE/ORDERING INFORMATION

PRODUCT	PACKAGE	PACKAGE DRAWING NUMBER	OPERATION TEMPERATURE RANGE	PACKAGE MARKING	ORDERING NUMBER†	TRANSPORT MEDIA
PCM1606E	20-Lead SSOP	ZZ334-1	–25°C to 85°C	PCM1606E	PCM1606E	TUBE
					PCM1606E/2K	Tape and Reel

† Models with a slash (/) are available only in tape and reel in the quantities indicated (e.g., /2K indicates 2000 devices per reel). Ordering 2000 pieces of PCM1606Y/2K gets a single 2000-piece tape and reel.

## functional block diagram

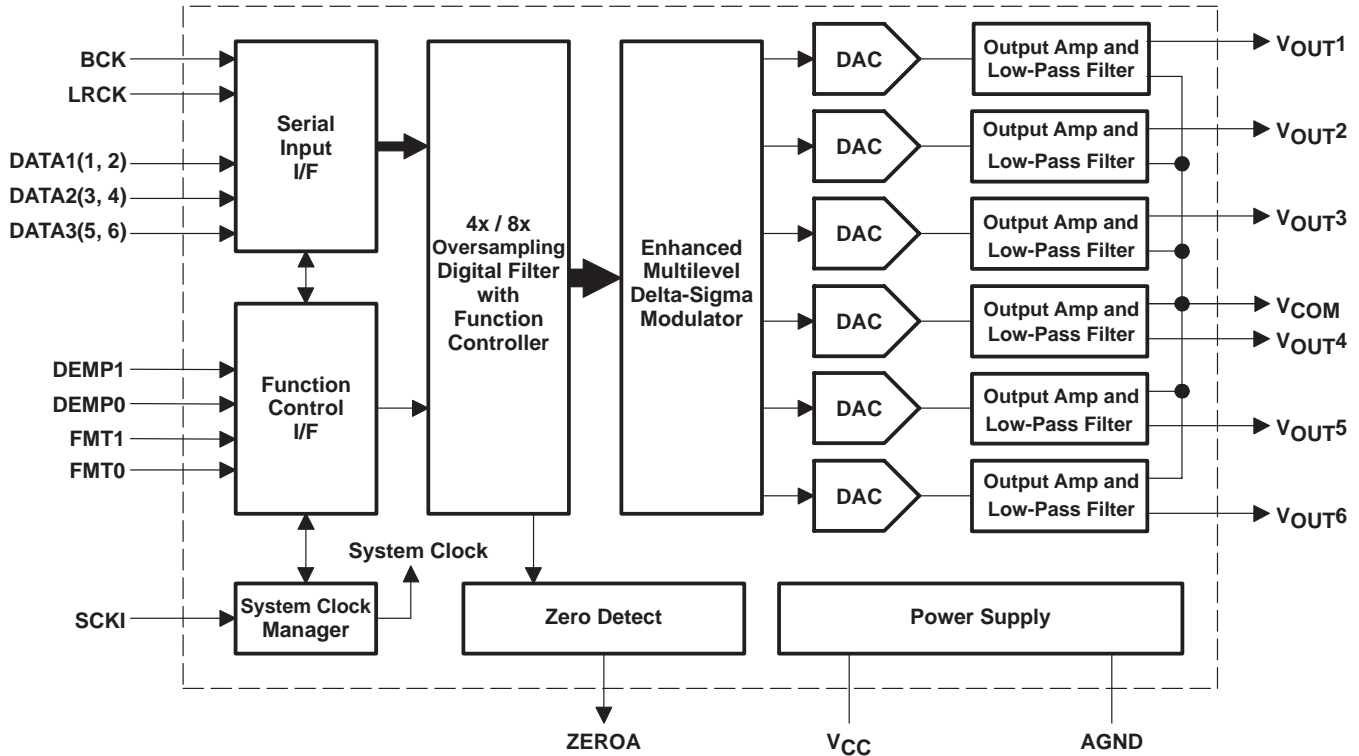

## Terminal Functions

TERMINAL NAME	PIN	I/O	DESCRIPTIONS
AGND	7	—	Analog and digital ground
BCK	19	I	Shift clock input for serial audio data (see Note 2)
DATA1	1	I	Serial audio data input for $V_{OUT1}$ and $V_{OUT2}$ (see Note 2)
DATA2	2	I	Serial audio data input for $V_{OUT3}$ and $V_{OUT4}$ (see Note 2)
DATA3	3	I	Serial audio data input for $V_{OUT5}$ and $V_{OUT6}$ (see Note 2)
DEMP0	16	I	De-emphasis control (see Note 1)
DEMP1	17	I	De-emphasis control (see Note 1)
FMT1	4	I	Format select (see Note 1)
FMT0	5	I	Format select (see Note 1)
LRCK	18	I	Left and right clock input. This clock is equal to the sampling rate, $f_S$ (see Note 2)
SCKI	20	I	System clock in. Input frequency is 128 $f_S$ , 192 $f_S$ , 256 $f_S$ , 384 $f_S$ , 512 $f_S$ or 768 $f_S$ (see Note 2)
VCC	15	—	Analog and digital power supply, 5 V
VCOM	14	—	Common voltage output. This pin should be bypassed with a 10- $\mu$ F capacitor to AGND
VOUT1	10	O	Voltage output for audio signal corresponding to L-channel on DATA1. Up to 192 kHz
VOUT2	11	O	Voltage output for audio signal corresponding to R-channel on DATA1. Up to 192 kHz
VOUT3	12	O	Voltage output for audio signal corresponding to L-channel on DATA2. Up to 96 kHz
VOUT4	13	O	Voltage output for audio signal corresponding to R-channel on DATA2. Up to 96 kHz
VOUT5	8	O	Voltage output for audio signal corresponding to L-channel on DATA3. Up to 96 kHz
VOUT6	9	O	Voltage output for audio signal corresponding to R-channel on DATA3. Up to 96 kHz
ZEROA	6	O	Zero-data flag. Logical AND of ZERO1 through ZERO6

NOTES: 1. Schmitt-trigger input with internal pulldown.  
2. Schmitt-trigger input.

absolute maximum ratings over operating free-air temperature (unless otherwise noted)<sup>†</sup>

Supply voltage, $V_{CC}$	6.5 V
Digital input voltage	-0.3 V to $V_{CC} + 0.3$ V
Analog input voltage	-0.3 V to $V_{CC} + 0.3$ V
Input current (except power supply)	$\pm 10$ mA
Ambient temperature under bias	-40°C to 125°C
Storage temperature	-55°C to 150°C
Junction temperature	150°C
Lead temperature (soldering, 5s)	260°C, 5s
Package temperature (IR reflow, 10s)	235°C, 10s

<sup>†</sup> Stresses beyond those listed under "absolute maximum ratings" may cause permanent damage to the device. These are stress ratings only, and functional operation of the device at these or any other conditions beyond those indicated under "recommended operating conditions" is not implied. Exposure to absolute-maximum-rated conditions for extended periods may affect device reliability.

electrical characteristics, all specifications at  $T_A = 25^\circ\text{C}$ ,  $V_{CC} = 5\text{ V}$ ,  $f_S = 44.1\text{ kHz}$ , system clock =  $384 f_S$  and 24-bit data (unless otherwise noted)

PARAMETER	TEST CONDITIONS	PCM1606E			UNIT
		MIN	TYP	MAX	
RESOLUTION			24		Bits
<b>DATA FORMAT</b>					
	Audio data interface format	Standard, I <sup>2</sup> S, Left-Justified, TDM			
	Audio data bit length	16 or 24 bits, selectable			
	Audio data format	MSB first, 2s complement			
$f_S$	Sampling frequency	$V_{OUT1}, V_{OUT2}$	5	200	kHz
		$V_{OUT3}, V_{OUT4}, V_{OUT5}, V_{OUT6}$	5	100	
	System clock frequency	128, 192, 256, 384, 512, 768 $f_S$			
<b>DIGITAL INPUT/OUTPUT</b>					
	Logic family (TTL compatible)				
$V_{IH}$	High-level input voltage	2			V
$V_{IL}$	Low-level input voltage	0.8			V
$I_{IH}$	High-level input current	$V_{IN} = V_{CC}$	67	100	$\mu\text{A}$
$I_{IL}$	Low-level input current	$V_{IN} = 0\text{ V}$		-10	$\mu\text{A}$
$V_{OH}$	High-level output voltage	$I_{OH} = -4\text{ mA}$	2.4		V
$V_{OL}$	Low-level output voltage	$I_{OL} = 4\text{ mA}$		1	V
<b>DYNAMIC PERFORMANCE</b>					
THD+N	Total harmonic distortion plus noise	$V_{OUT} = 0\text{ dB}$	$f_S = 44.1\text{ kHz}/384 f_S$	0.004%	0.01%
			$f_S = 96\text{ kHz}/256 f_S$	0.005%	
			$f_S = 192\text{ kHz}/128 f_S$	0.002%	
		$V_{OUT} = -60\text{ dB}$	$f_S = 44.1\text{ kHz}/384 f_S$	1%	
			$f_S = 96\text{ kHz} / 256 f_S$	1.2%	
			$f_S = 192\text{ kHz}/128 f_S$	1%	
Dynamic range	EIAJ, A-weighted, $f_S = 44.1\text{ kHz}/384 f_S$		98	103	dB
	A-weighted, $f_S = 96\text{ kHz}/256 f_S$			99	
	A-weighted, $f_S = 192\text{ kHz}/128 f_S$			101	
Signal-to-noise ratio	EIAJ, A-weighted, $f_S = 44.1\text{ kHz}/384 f_S$		98	103	dB
	A-weighted, $f_S = 96\text{ kHz}/256 f_S$			100	
	A-weighted, $f_S = 192\text{ kHz}/128 f_S$			101	
Channel separation	$f_S = 44.1\text{ kHz}/384 f_S$		95	100	dB
	$f_S = 96\text{ kHz}/256 f_S$			95	
	$f_S = 192\text{ kHz}/128 f_S$			100	
Level linearity error	$V_{OUT} = -90\text{ dB}$			$\pm 0.5$	dB
<b>DC ACCURACY</b>					
Gain error				$\pm 1\%$ FSR	
Gain mismatch, channel-to-channel				$\pm 1.3\%$ FSR	
Bipolar zero error	$V_{OUT} = 0.5 V_{CC}$ at BPZ			$\pm 30$	mV
<b>ANALOG OUTPUT</b>					
Output voltage	Full scale (-0 dB)			62% of $V_{CC}$	V <sub>p-p</sub>
Center voltage				50% of $V_{CC}$	V <sub>dc</sub>
Load impedance	Ac load		5		k $\Omega$

electrical characteristics, all specifications at  $T_A = 25^\circ\text{C}$ ,  $V_{CC} = 5\text{ V}$ ,  $f_S = 44.1\text{ kHz}$ , system clock =  $384 f_S$  and 24-bit data (unless otherwise noted) (continued)

PARAMETER	TEST CONDITIONS	PCM1606E			UNIT	
		MIN	TYP	MAX		
<b>DIGITAL FILTER PERFORMANCE</b>						
<b>FILTER CHARACTERISTICS</b>						
Passband	$\pm 0.03\text{ dB}$			$0.454 f_S$		
	$-3\text{ dB}$			$0.487 f_S$		
Stopband		$0.546 f_S$				
Passband ripple				$\pm 0.03$	dB	
Stopband attenuation	Stopband = $0.546 f_S$		$-50$		dB	
	Stopband = $0.567 f_S$		$-55$			
<b>ANALOG FILTER PERFORMANCE</b>						
Frequency response	At 20 kHz		$-0.03$		dB	
<b>POWER SUPPLY REQUIREMENTS (see Note 4)</b>						
$V_{CC}$	Voltage range		4.5	5	5.5	VDC
$I_{CC}$	Supply current	$f_S = 44.1\text{ kHz}/384 f_S$		50	65	mA
		$f_S = 96\text{ kHz}/256 f_S$		72		
		$f_S = 192\text{ kHz}/128 f_S$		68		
Power dissipation		$f_S = 44.1\text{ kHz}/384 f_S$		250	358	mW
		$f_S = 96\text{ kHz}/256 f_S$		360		
		$f_S = 192\text{ kHz}/128 f_S$		340		
<b>TEMPERATURE RANGE</b>						
Operation temperature			$-25$		85	$^\circ\text{C}$
$\theta_{JA}$	Thermal resistance	20-pin SSOP		115		$^\circ\text{C}/\text{W}$

- NOTES: 3. Analog performance specs are tested using System Two Cascade Plus by Audio Precision with 400-Hz HPF, 30-kHz LPF on at RMS with 20-kHz LPF, 400-Hz HPF in calculation.  
Shibasoku #725 THD meter, 400 Hz HPF, 30 kHz LPF on, at average mode with 20-kHz bandwidth limiting. The load connected to the analog output is  $5\text{ k}\Omega$  or larger via capacitance coupling.
4. Condition in 192-kHz operation is channel 3 through channel 6 are disabled.

## timing requirements

### system clock input

The PCM1606 requires a system clock for operating the digital interpolation filters and multilevel delta-sigma modulators. The system clock is applied at the SCKI (pin 20). Table 1 shows examples of system clock frequencies for common audio sampling rates.

Figure 1 shows the timing requirements for the system clock input. For optimal performance, it is important to use a clock source with low phase jitter and noise. Texas Instruments' PLL1700 multiclock generator is an excellent choice for providing the PCM1606 system clock source.

The 192-kHz sampling frequency operation is available on DATA1 for  $V_{OUT1}$  and  $V_{OUT2}$ . When the system clock of  $128 f_S$  or  $192 f_S$  is detected,  $V_{OUT3}$ ,  $V_{OUT4}$ ,  $V_{OUT5}$  and  $V_{OUT6}$  are automatically forced to the bipolar zero level ( $= 0.5 V_{CC}$ ). Table 1 lists the typical system clock frequency.

timing requirements (continued)

power-on reset functions

The PCM1606 includes a power-on reset function. Figure 2 shows the operation of this function. With the system clock active and  $V_{CC} > 3\text{ V}$  typical (2.2 V to 3.7 V), the power-on reset function is enabled. The initialization sequence requires 1024 system clocks from the time  $V_{CC} > 3\text{ V}$ . After the initialization period, the PCM1606 is set to its reset default state.

Table 1. System Clock Rates for Common Audio Sampling Frequencies

SAMPLING FREQUENCY	SYSTEM CLOCK FREQUENCY ( $f_{SCLK}$ ) (MHz)					
	128 $f_S$	192 $f_S$	256 $f_S$	384 $f_S$	512 $f_S$	768 $f_S$
8 kHz	—	—	2.048	3.072	4.096	6.144
16 kHz	—	—	4.096	6.144	8.192	12.288
32 kHz	—	—	8.192	12.288	16.384	24.576
44.1 kHz	—	—	11.2896	16.9344	22.5792	33.8688
48 kHz	—	—	12.288	18.432	24.576	36.864
96 kHz	—	—	24.576	36.864	49.152	See Note 5
192 kHz	24.576	36.864	See Note 6	See Note 6	See Note 6	See Note 6

NOTES: 5. The 768- $f_S$  system clock rate is not supported for  $f_S > 64\text{ kHz}$ .  
 6. This system clock is not supported for the given sampling frequency.

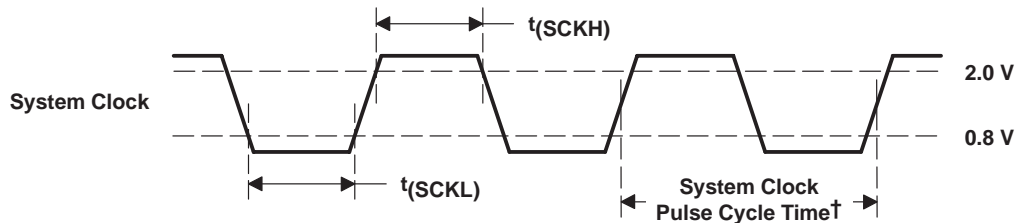

†  $1/128 f_S$ ,  $1/256 f_S$ ,  $1/384 f_S$ ,  $1/512 f_S$  and  $1/768 f_S$ .

PARAMETERS		MIN	MAX	UNIT
$t(SCKH)$	System clock pulse duration HIGH	10		ns
$t(SCKL)$	System clock pulse duration LOW	10		ns

Figure 1. System Clock Timing

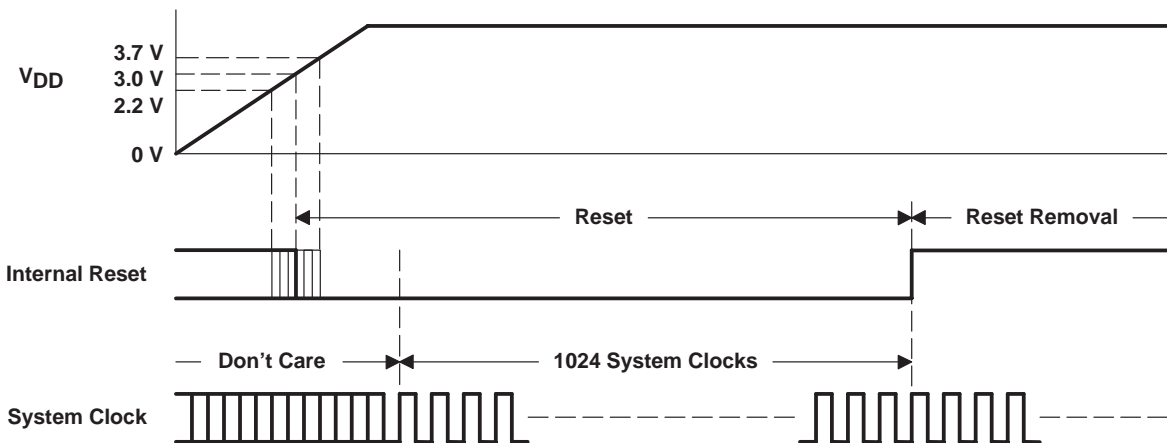

Figure 2. Power-On Reset Timing

## timing requirements (continued)

### audio serial interface

The audio serial interface for the PCM1606 comprises a 5-wire synchronous serial port. It includes LRCK (pin 18), BCK (pin 19), DATA1 (pin 1), DATA2 (pin 2) and DATA3 (pin 3). BCK is the serial audio bit clock and is used to clock the serial data present on DATA1, DATA2, and DATA3 into the audio interface serial shift registers. Serial data is clocked into the PCM1606 on the rising edge of BCK. LRCK is the serial audio left/right word clock. LRCK is used to latch serial data into the serial audio interface internal registers.

Both LRCK and BCK must be synchronous to the system clock. Ideally, it is recommended that LRCK and BCK be derived from the system clock input or output, SCKI. The left/right clock, LRCK, is operated at the sampling frequency ( $f_S$ ). The bit clock, BCK, may be operated at 32, 48, or 64 times the sampling frequency.

### audio data formats and timing

The PCM1606 supports industry-standard audio data formats, including standard, I<sup>2</sup>S, left-justified, and TDM. The data formats are shown in Figure 6. Data formats are selected using the format pins, FMT1 (pin 4) and FMT0 (pin 5). All formats require binary 2s complement, MSB-first audio data. Figure 3 shows a detailed timing diagram for the serial audio interface, with the exception of TDM format.

DATA1, DATA2, and DATA3 each carry two audio channels, designated as the left and right channels. The left channel data always precedes the right channel data in the serial data stream for all data formats. Table 2 shows the mapping of the digital input data to the analog output pins.

TDM format is able to interface by 3-wire synchronous serial port. All data inputs from DATA1, BCK can be operated at 128, 256, and 512 times the sampling frequency. The rising edge of LRCK means the start of a data frame. Only channel 1 and channel 2 data are acceptable at the 192-kHz sampling frequency ( $f_S$ ); channel 3, channel 4, channel 5, and channel 6 data are don't care.

Figure 4 shows the timing requirements for BCK input for TDM format. Figure 5 shows the detailed timing diagram for TDM format.

**Table 2. Audio Input Data to Analog Output Mapping**

DATA INPUT	CHANNEL	ANALOG OUTPUT
DATA1	Left	V <sub>OUT1</sub> <sup>†</sup>
DATA1	Right	V <sub>OUT2</sub> <sup>†</sup>
DATA2	Left	V <sub>OUT3</sub> <sup>‡</sup>
DATA2	Right	V <sub>OUT4</sub> <sup>‡</sup>
DATA3	Left	V <sub>OUT5</sub> <sup>‡</sup>
DATA3	Right	V <sub>OUT6</sub> <sup>‡</sup>

<sup>†</sup> Up to 192 kHz

<sup>‡</sup> Up to 96 kHz

timing requirements (continued)

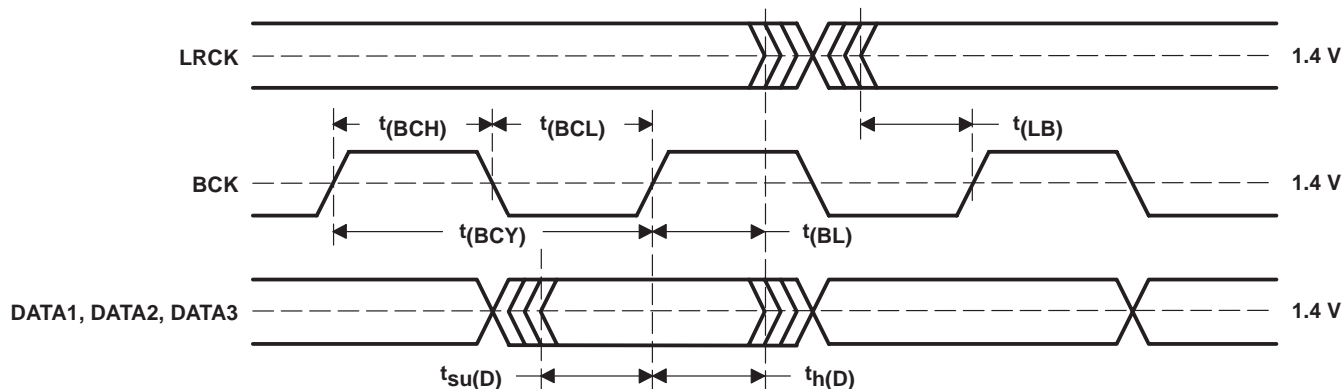

PARAMETER		MIN	MAX	UNIT
t(BCY)	BCK pulse cycle time		$32 f_S / 48 f_S / 64 f_S^\dagger$	
t(BCH)	BCK high-level time	35		ns
t(BCL)	BCK low-level time	35		ns
t(BL)	BCK rising edge to LRCK edge	10		ns
t(LB)	LRCK falling edge to BCK rising edge	10		ns
t <sub>su</sub> (D)	DATA setup time	10		ns
t <sub>h</sub> (D)	DATA hold time	10		ns

<sup>†</sup> f<sub>S</sub> is the sampling frequency (e.g., 44.1 kHz, 48 kHz, 96 kHz, etc.)

Figure 3. Audio Interface Timing

Table 3. Bit Clock Rates for TDM Format Sampling Frequencies

SAMPLING FREQUENCY	SYSTEM CLOCK FREQUENCY (f <sub>SCKI</sub> ) (MHz)		
	128 f <sub>S</sub>	256 f <sub>S</sub>	512 f <sub>S</sub>
8 kHz	—	2.048	4.096
16 kHz	—	4.096	8.192
32 kHz	—	8.192	16.384
44.1 kHz	—	11.2896	22.5792
48 kHz	—	12.288	24.576
96 kHz	—	24.576	49.152
192 kHz	24.576	See Note 7	See Note 7

NOTE 7: This bit clock is not supported for the given sampling frequency.

timing requirements (continued)

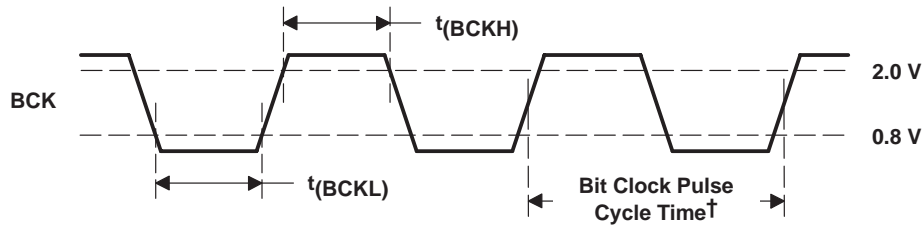

PARAMETERS		MIN	MAX	UNIT
$t_{(BCKH)}$	Bit clock pulse duration HIGH	10		ns
$t_{(BCKL)}$	Bit clock pulse duration LOW	10		ns

†  $1/128 f_S$ ,  $1/256 f_S$ , and  $1/512 f_S$ .

Figure 4. Bit Clock Timing for TDM Format

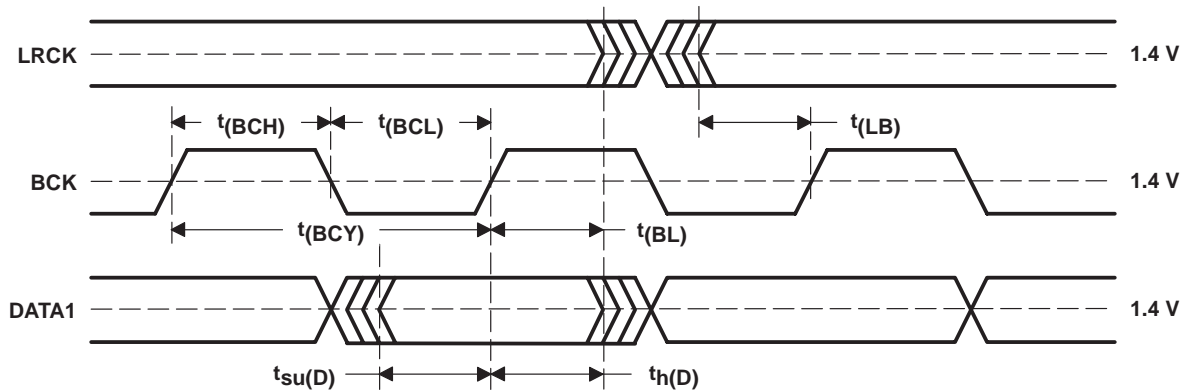

PARAMETER		MIN	MAX	UNIT
$t_{(BCY)}$	BCK pulse cycle time	20		ns
$t_{(BCH)}$	BCK high-level time	10		ns
$t_{(BCL)}$	BCK low-level time	10		ns
$t_{(BL)}$	BCK rising edge to LRCK edge	7		ns
$t_{(LB)}$	LRCK falling edge to BCK rising edge	7		ns
$t_{su(D)}$	DATA setup time	7		ns
$t_{h(D)}$	DATA hold time	7		ns

Figure 5. Audio Interface Timing for TDM Format

timing requirements (continued)

(1) Standard Data Format; L-Channel = HIGH, R-Channel = LOW

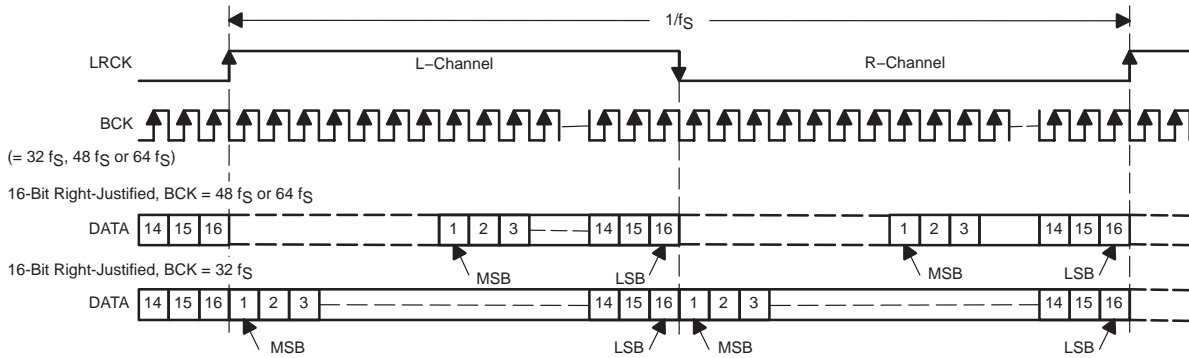

(2) Left-Justified Data Format; L-Channel = HIGH, R-Channel = LOW

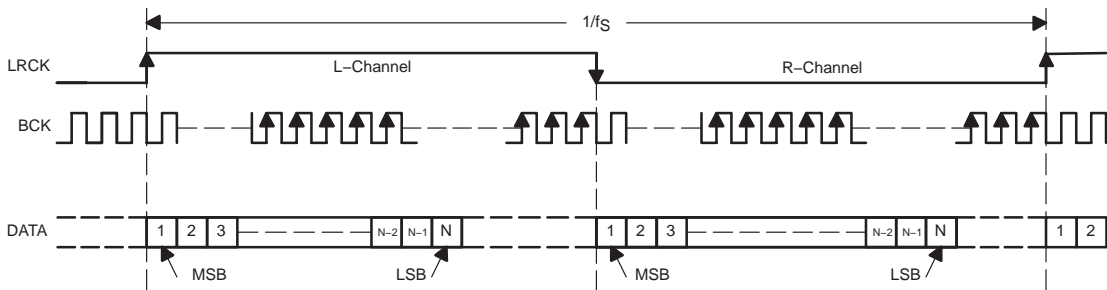

(3) I<sup>2</sup>S Data Format; L-Channel = LOW, R-Channel = HIGH

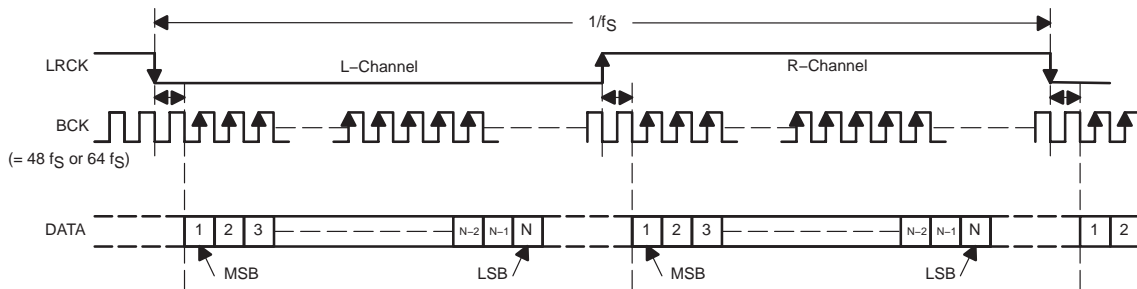

Figure 6. Audio Data Input Format

## timing requirements (continued)

### (4) TDM Data Format

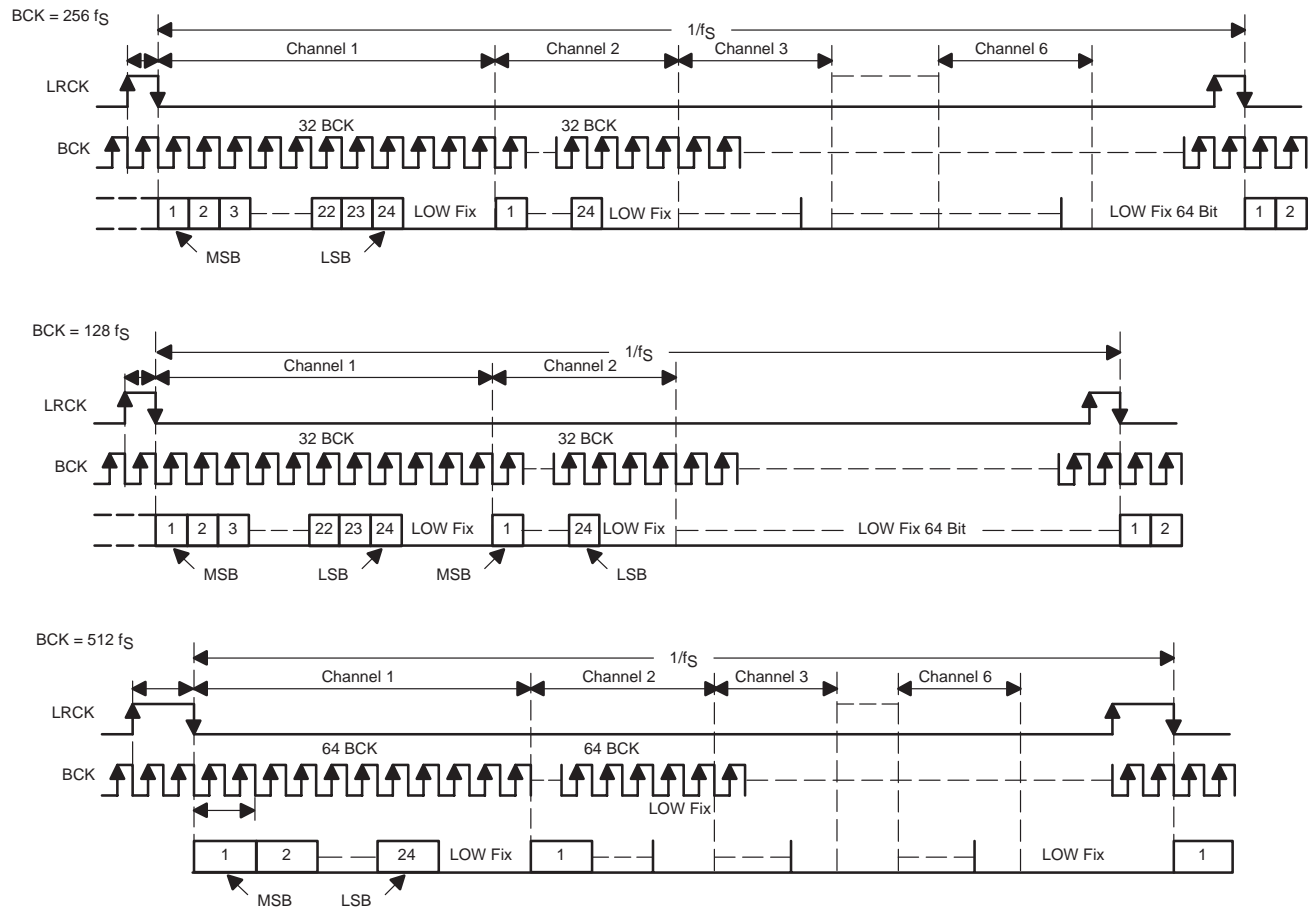

Figure 6. Audio Data Input Format (Continued)

## functional description

The PCM1606 has several built-in functions including digital input data format selection and digital de-emphasis. These functions are hardware controlled with static control signals and used on pin FMT1 (pin 4), pin FMT0 (pin 5), pin DEMP1 (pin 17), and DEMP0 (pin 16).

### data format selection

The PCM audio data format can be selected by pin FMT1 (pin 4) and FMT0 (pin 5) as shown in Table 4.

Table 4. Data Format Control

FMT1 (pin 4)	FMT0 (pin 5)	AUDIO INTERFACE
LOW	LOW	I <sup>2</sup> S
LOW	HIGH	TDM
HIGH	LOW	Standard
HIGH	HIGH	Left-justified

functional description (continued)

de-emphasis control

The de-emphasis control can be selected by DEMP1 (pin 17) and DEMP0 (pin 16). See Table 5.

Table 5. De-Emphasis Control

DEMT1 (pin 17)	DEMT0 (pin 16)	AUDIO INTERFACE
LOW	LOW	OFF
LOW	HIGH	48 kHz
HIGH	LOW	44.1 kHz
HIGH	HIGH	32 kHz

analog outputs

The PCM1606 includes six independent output channels,  $V_{OUT1}$  through  $V_{OUT6}$ . These are unbalanced outputs, each capable of driving 3.1 Vp-p typical into a 5-k $\Omega$  ac load with  $V_{CC} = 5$  V. The internal output amplifiers for  $V_{OUT1}$  through  $V_{OUT6}$  are dc-biased to the common-mode (or bipolar zero) voltage, equal to  $V_{CC}/2$ .

The output amplifiers include an RC continuous-time filter, which helps to reduce the out-of-band noise energy present at the DAC outputs due to the noise shaping characteristics of the PCM1606's delta-sigma D/A converters. The frequency response of this filter is shown in Figure 7. By itself, this filter is not enough to attenuate the out-of-band noise to an acceptable level for most applications. An external low-pass filter is required to provide sufficient out-of-band noise rejection. Further discussion of DAC post-filter circuits is provided in the *Application Information* section of this data sheet.

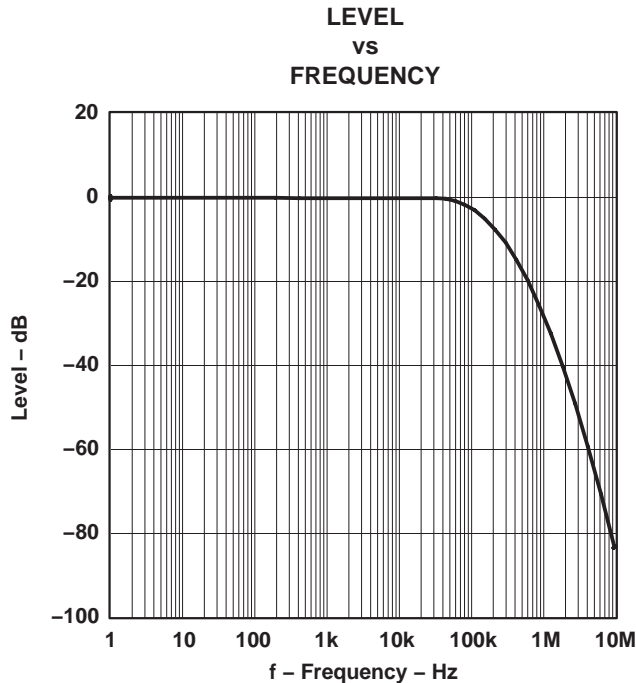

Figure 7. Output Filter Frequency Response

## functional description (continued)

### $V_{COM}$ output

One unbuffered common-mode voltage output pin,  $V_{COM}$  (pin 14) is brought out for decoupling purposes. This pin is nominally biased to a dc voltage level equal to  $V_{CC}/2$ . If this pin is to be used to bias external circuitry, a voltage follower is required for buffering purposes. Figure 8 shows an example of using the  $V_{COM}$  pin for external biasing applications.

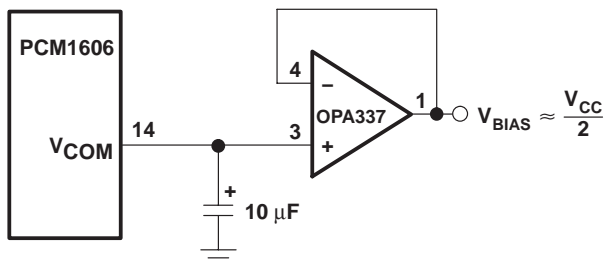

Figure 8. Biasing External Circuits Using the  $V_{COM}$  Pin

### zero flag

#### zero detect condition

Zero detection for each output channel is independent from the others. If the data for a given channel remains at a 0 level for 1024 sample periods (or LRCK clock periods), a zero detect condition exists for that channel.

#### zero output flag

When the data for all channels remains at a 0 level for 1024 sample periods (or LRCK clock periods), the ZEROA (pin 6) is set to a logic 1 state. The zero flag pin can be used to operate external mute circuits, or used as a status indicator for a microcontroller, audio signal processor, or other digitally controlled functions.

TYPICAL CHARACTERISTICS—DIGITAL FILTER

AMPLITUDE  
vs  
FREQUENCY

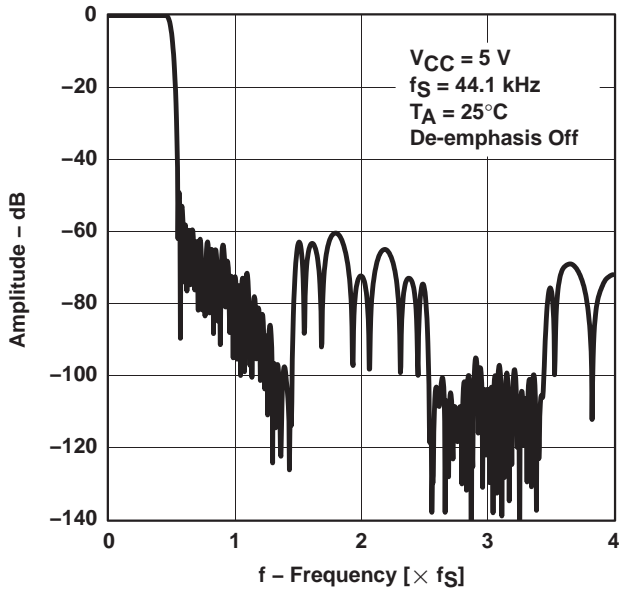

Figure 9

AMPLITUDE  
vs  
FREQUENCY

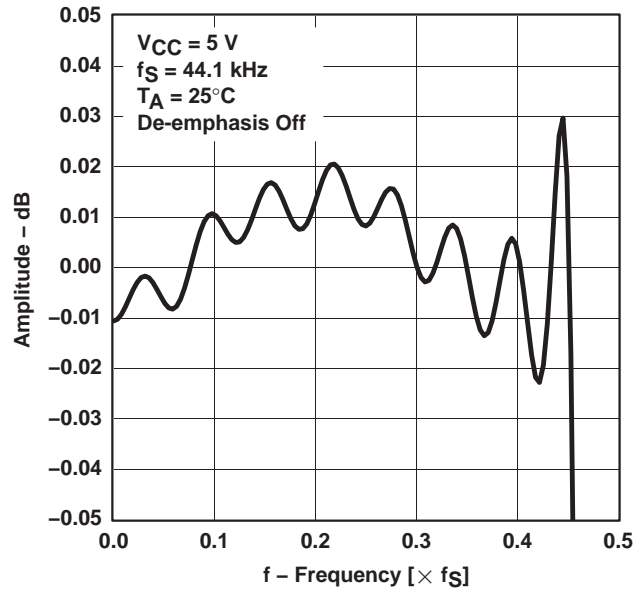

Figure 10

DE-EMPHASIS LEVEL  
vs  
FREQUENCY

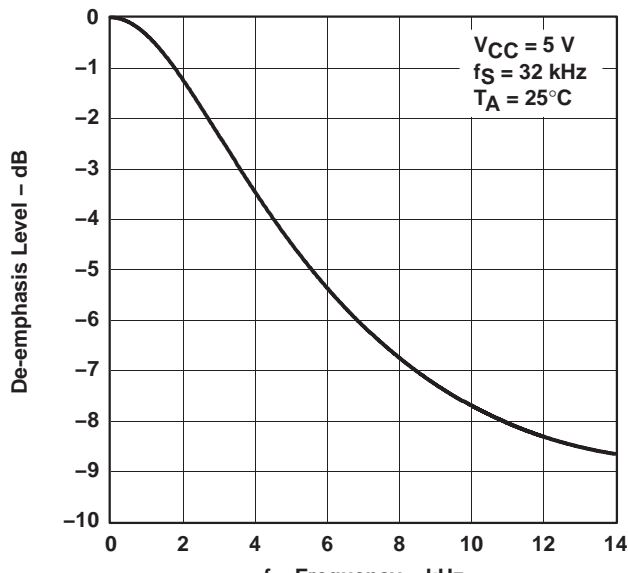

Figure 11

DE-EMPHASIS ERROR  
vs  
FREQUENCY

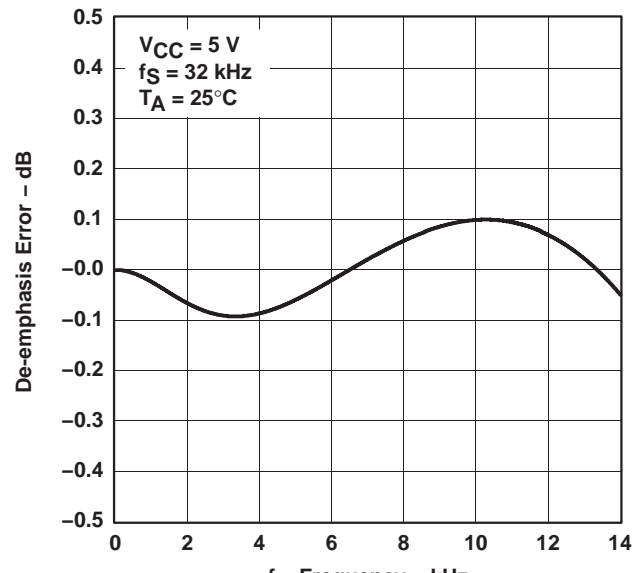

Figure 12

All specifications at  $T_A = 25^\circ\text{C}$ ,  $V_{CC} = 5\text{ V}$ ,  $f_S = 44.1\text{ kHz}$ , system clock =  $384 f_S$  and 24-bit data, unless otherwise noted.

TYPICAL CHARACTERISTICS—DIGITAL FILTER

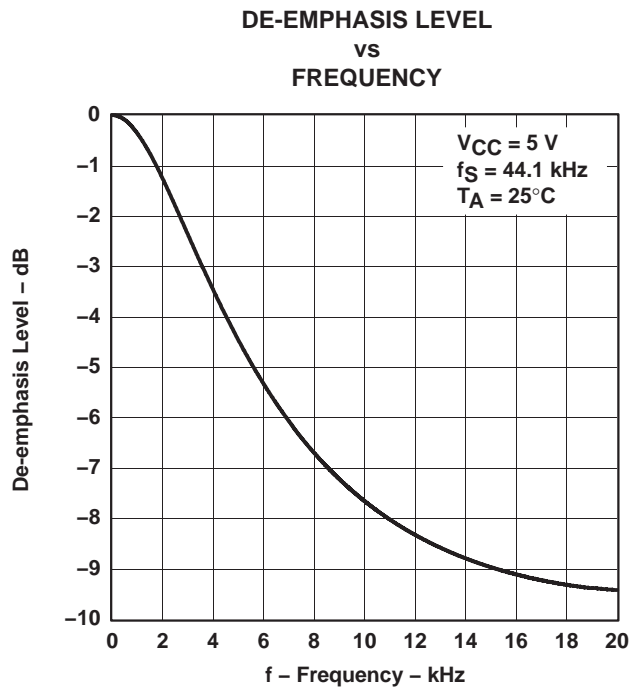

Figure 13

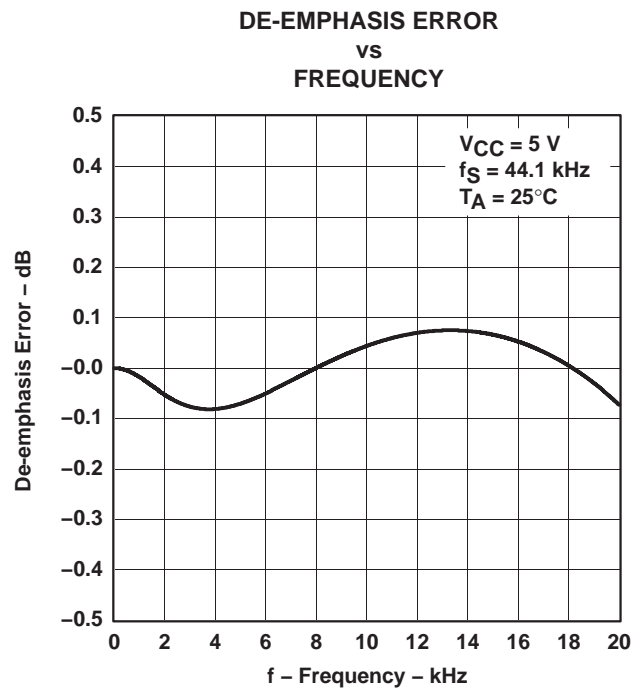

Figure 14

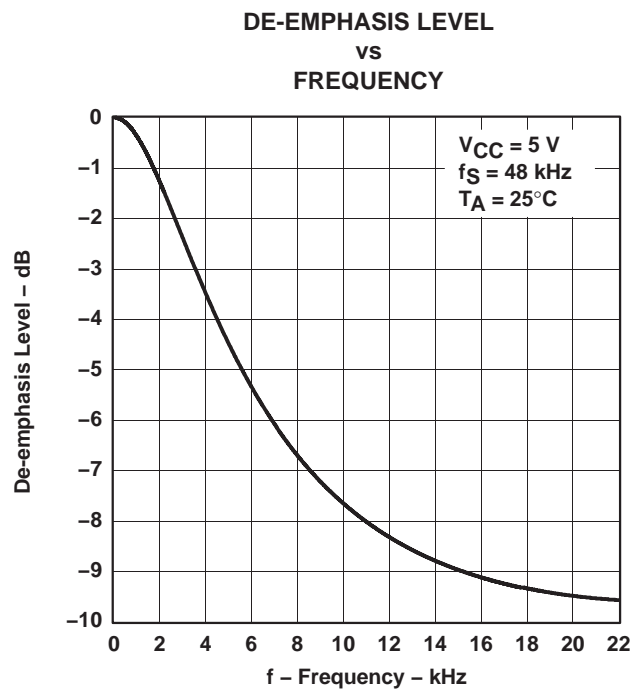

Figure 15

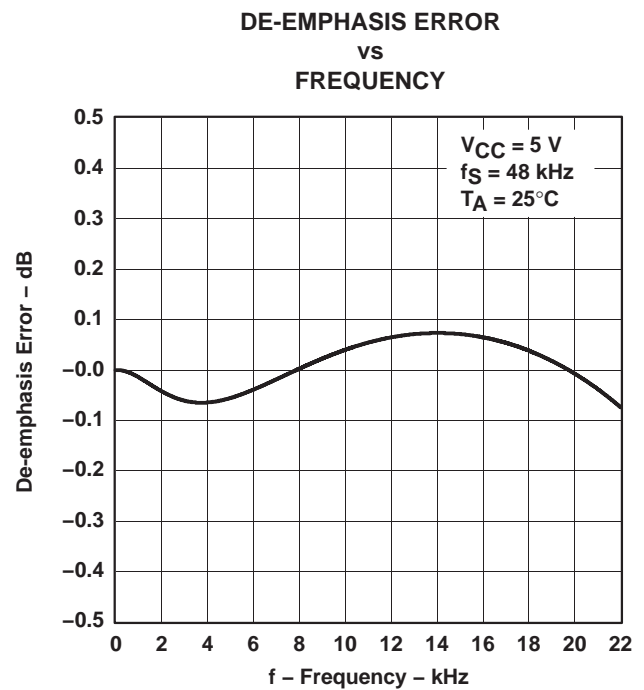

Figure 16

All specifications at  $T_A = 25^\circ\text{C}$ ,  $V_{CC} = 5\text{ V}$ ,  $f_S = 44.1\text{ kHz}$ , system clock =  $384 f_S$  and 24-bit data, unless otherwise noted.

TYPICAL CHARACTERISTICS—ANALOG DYNAMIC PERFORMANCE

TOTAL HARMONIC DISTORTION + NOISE vs SUPPLY VOLTAGE

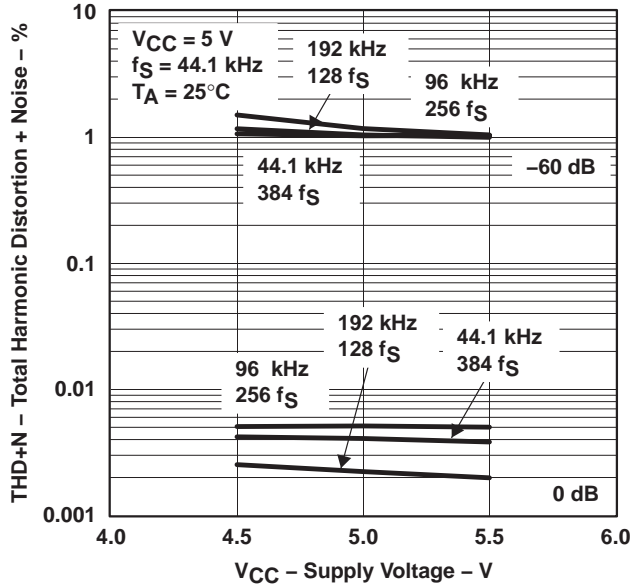

Figure 17

DYNAMIC RANGE vs SUPPLY VOLTAGE

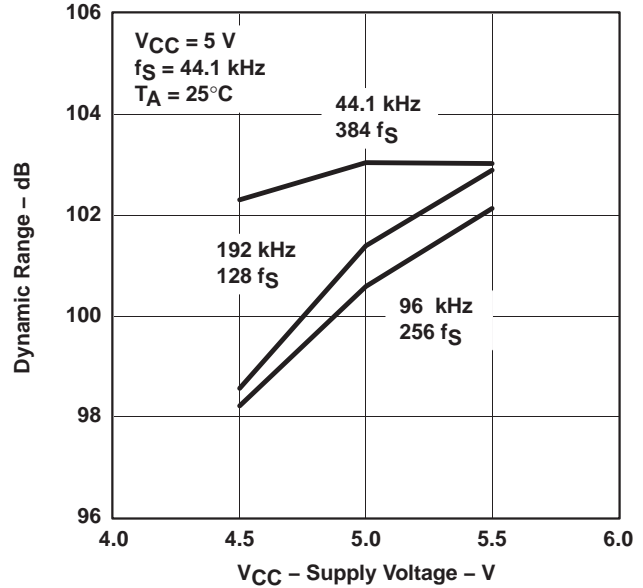

Figure 18

SNR vs SUPPLY VOLTAGE

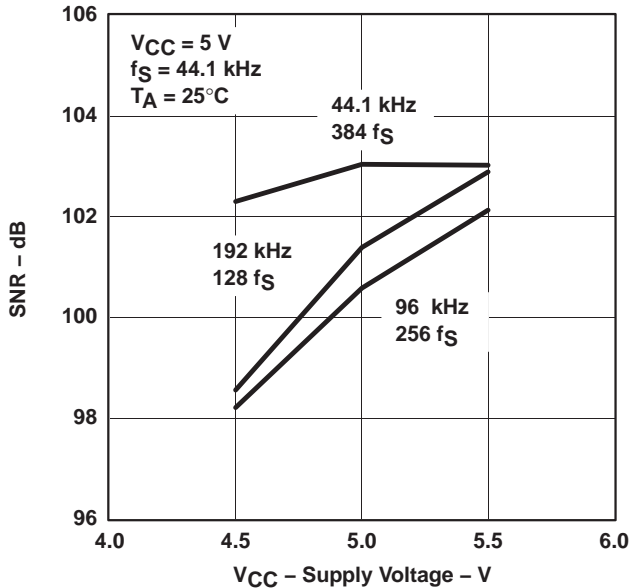

Figure 19

CHANNEL SEPARATION vs SUPPLY VOLTAGE

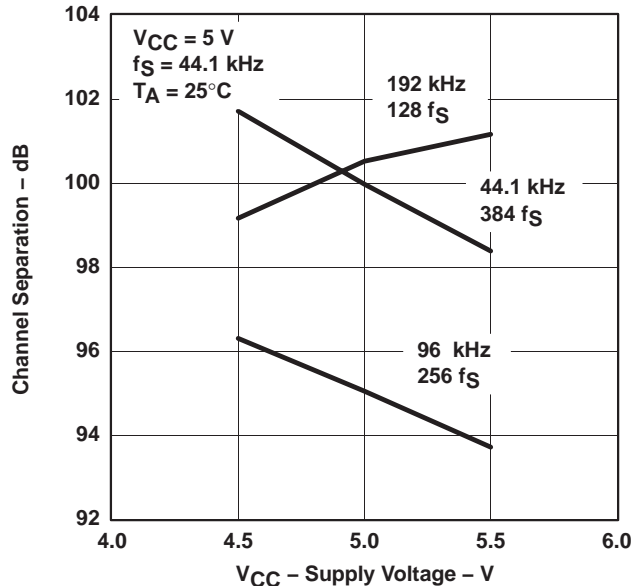

Figure 20

All specifications at  $T_A = 25^\circ\text{C}$ ,  $V_{CC} = 5\text{ V}$ ,  $f_S = 44.1\text{ kHz}$ , system clock =  $384\text{ fS}$  and 24-bit data, unless otherwise noted.

TYPICAL CHARACTERISTICS—ANALOG DYNAMIC PERFORMANCE

TOTAL HARMONIC DISTORTION + NOISE  
vs  
FREE-AIR TEMPERATURE

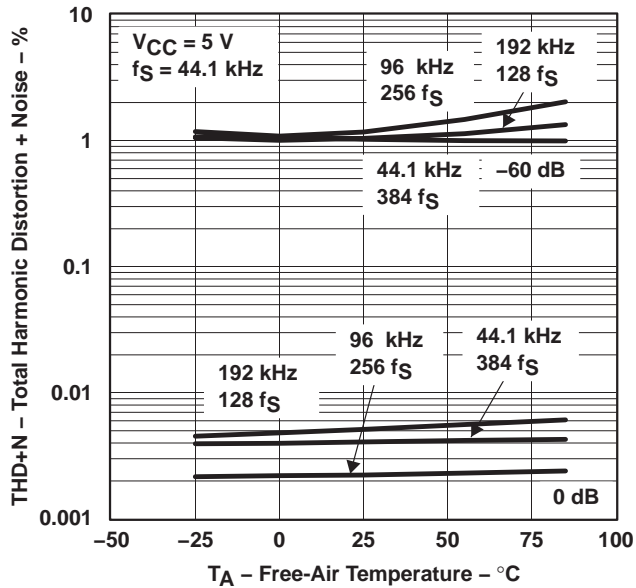

Figure 21

DYNAMIC RANGE  
vs  
FREE-AIR TEMPERATURE

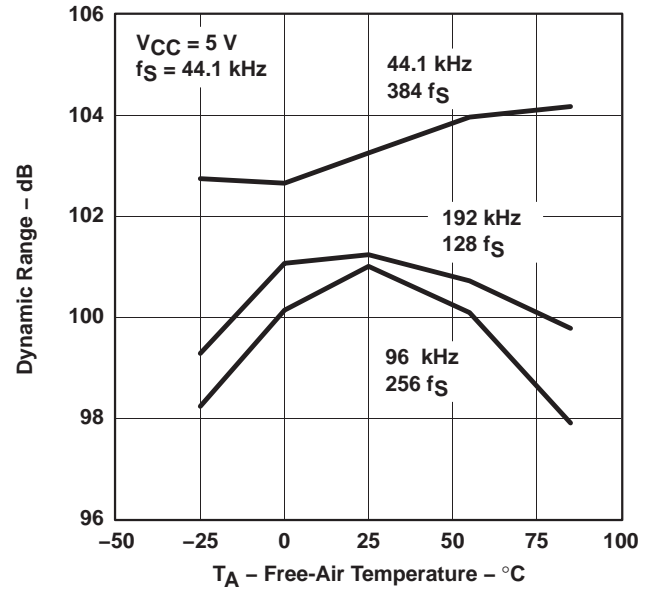

Figure 22

SNR  
vs  
FREE-AIR TEMPERATURE

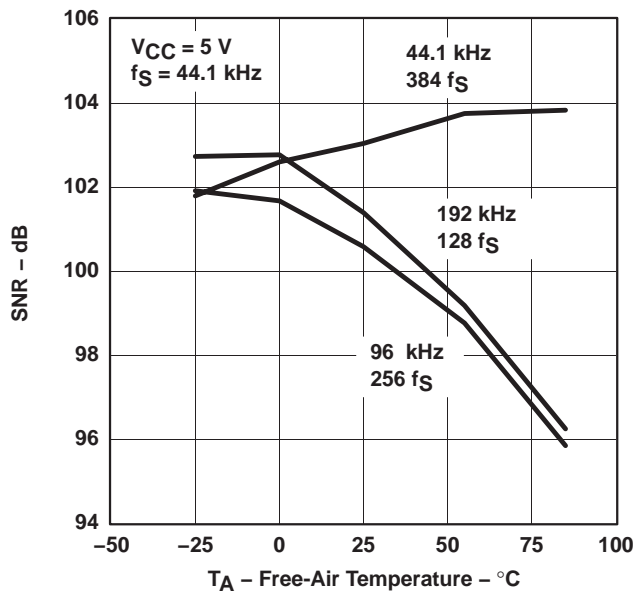

Figure 23

CHANNEL SEPARATION  
vs  
FREE-AIR TEMPERATURE

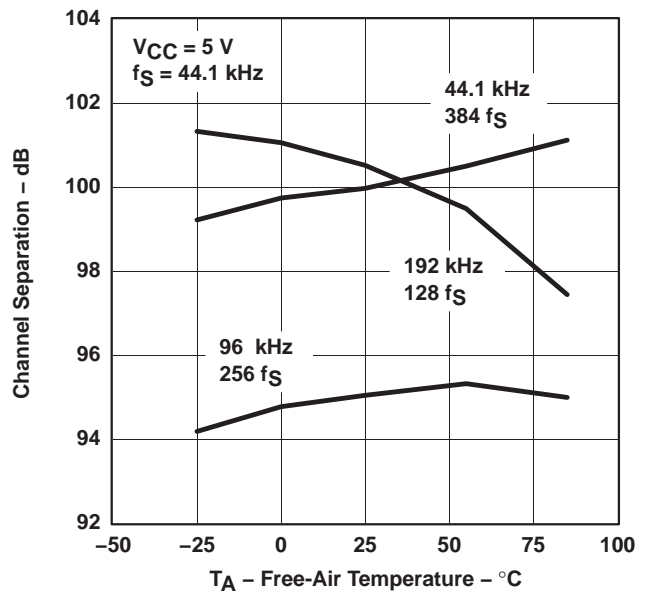

Figure 24

All specifications at  $T_A = 25^\circ\text{C}$ ,  $V_{CC} = 5\text{ V}$ ,  $f_S = 44.1\text{ kHz}$ , system clock =  $384\text{ fS}$  and 24-bit data, unless otherwise noted.

TYPICAL CHARACTERISTICS—ANALOG DYNAMIC PERFORMANCE

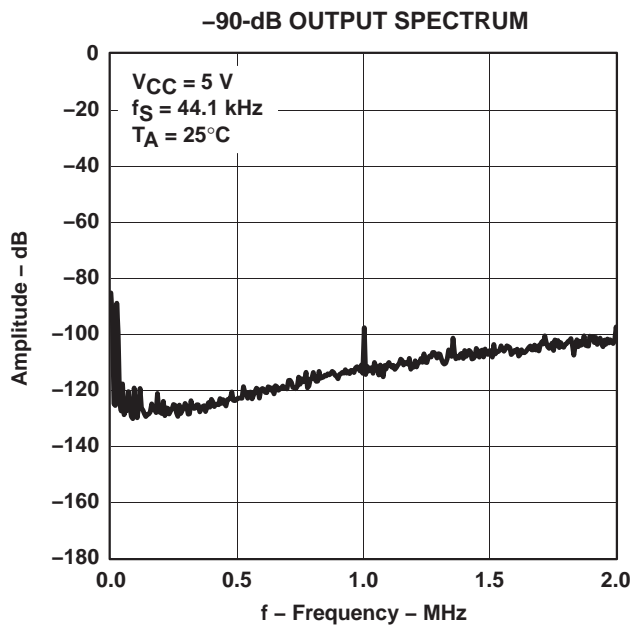

Figure 25

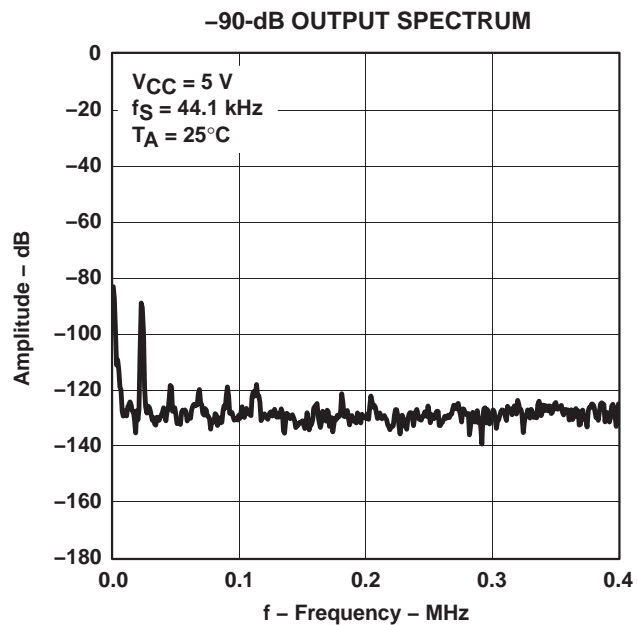

Figure 26

DYNAMIC RANGE  
VS  
JITTER

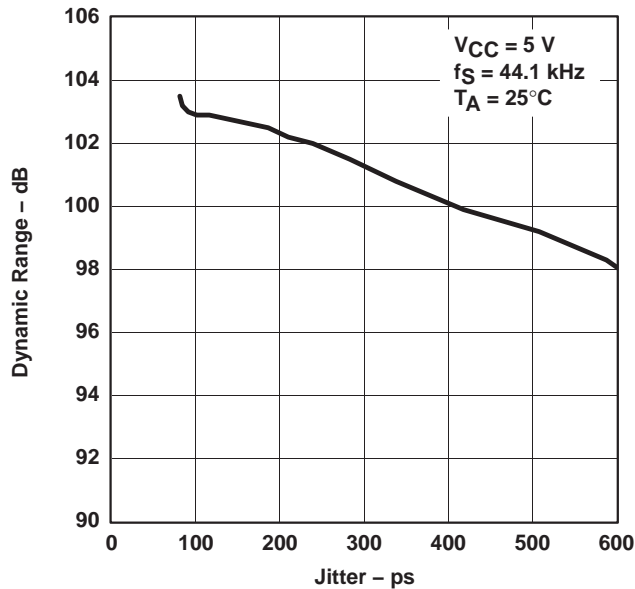

Figure 27

All specifications at  $T_A = 25^\circ\text{C}$ ,  $V_{CC} = 5\text{ V}$ ,  $f_S = 44.1\text{ kHz}$ , system clock =  $384 f_S$  and 24-bit data, unless otherwise noted.

## APPLICATION INFORMATION

## connection diagrams

A basic connection diagram is shown in Figure 28, with the necessary power supply bypassing and decoupling components. Texas Instruments recommends using the component values shown in Figure 28 for all designs.

A typical application diagram is shown in Figure 29. Texas Instruments' PLL1700 is used to generate the system clock input at SCKI, as well as generating the clock for the audio signal processor.

The use of series resistors ( $22\ \Omega$  to  $100\ \Omega$ ) is recommended for SCKI, LRCK, BCK, DATA1, DATA2, and DATA3. The series resistor combines with the stray PCB and device input capacitance to form a low-pass filter which removes high-frequency noise from the digital signal, thus, reducing high-frequency emission.

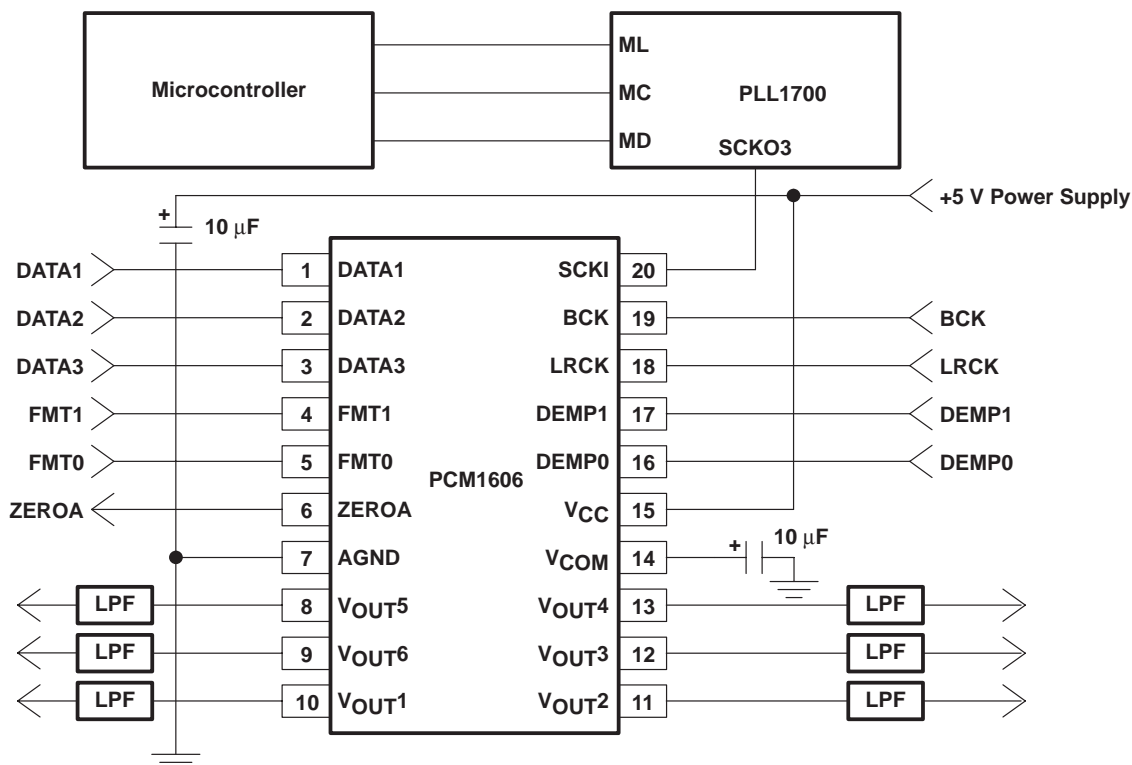
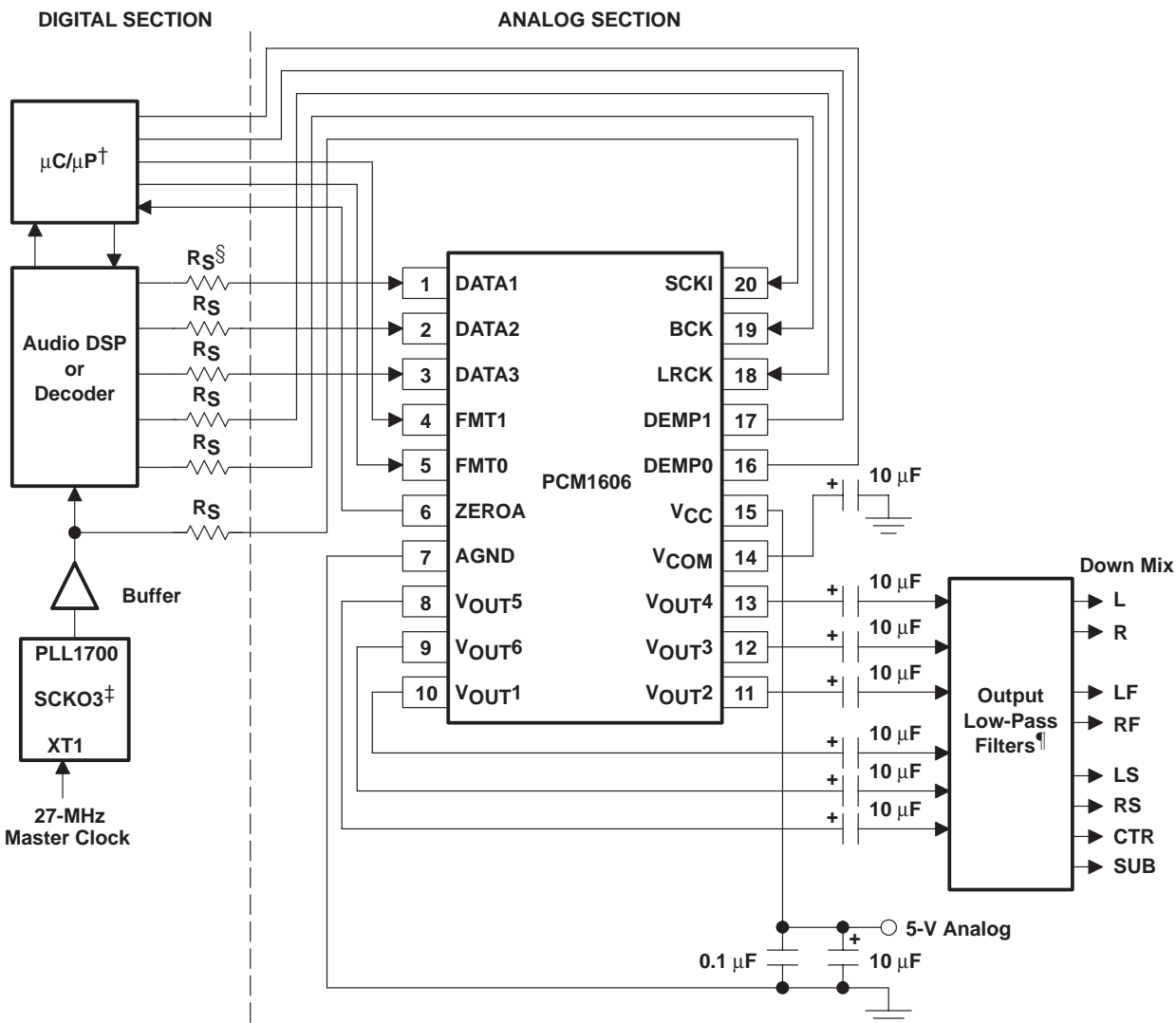

Figure 28. Basic Connection Diagram

APPLICATION INFORMATION



† Format and de-emphasis control can be provided by the DSP/decoder.  
 ‡ Actual clock output used is determined by the application.  
 §  $R_S = 22 \Omega$  to  $100 \Omega$   
 ¶ See the *Application Information* section of this data sheet for more information.

Figure 29. Typical Application Diagram

power supply and grounding

The PCM1606 requires a 5-V supply. The 5-V supply is used to power the DAC analog output-filter circuitry, the digital filter, and the serial interface circuitry.

Two capacitors are required for supply bypassing, as shown in Figure 29. These capacitors should be located as close as possible to the PCM1606 package. The 10- $\mu$ F capacitors should be tantalum or aluminum electrolytic, while the 0.1- $\mu$ F capacitors are ceramic (X7R type is recommended for surface-mount applications).

## APPLICATION INFORMATION

## D/A output filter circuits

Delta-sigma D/A converters utilize noise shaping techniques to improve in-band signal-to-noise ratio (SNR) performance at the expense of generating increased out-of-band noise above the Nyquist frequency, or  $f_s/2$ . The out-of-band noise must be low-pass filtered in order to provide optimal converter performance. This is accomplished by a combination of on-chip and external low-pass filtering.

Figure 30 and Figure 31 show the recommended external low-pass active filter circuits for dual- and single-supply applications. These circuits are 2nd-order Butterworth filters using the multiple feedback (MFB) circuit arrangement, which reduces sensitivity to passive component variations over frequency and temperature. For more information regarding MFB active filter design, see your local Texas Instruments sales office.

Because the overall system performance is defined by the quality of the D/A converters and their associated analog output circuitry, high-quality audio op amps are recommended for the active filters. Texas Instruments' OPA2134 and OPA2353 dual op amps are shown in Figure 30 and Figure 31, and are recommended for use with the PCM1606.

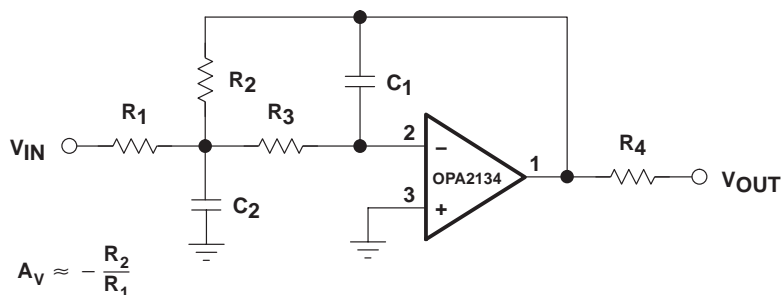

Figure 30. Dual-Supply Filter Circuit

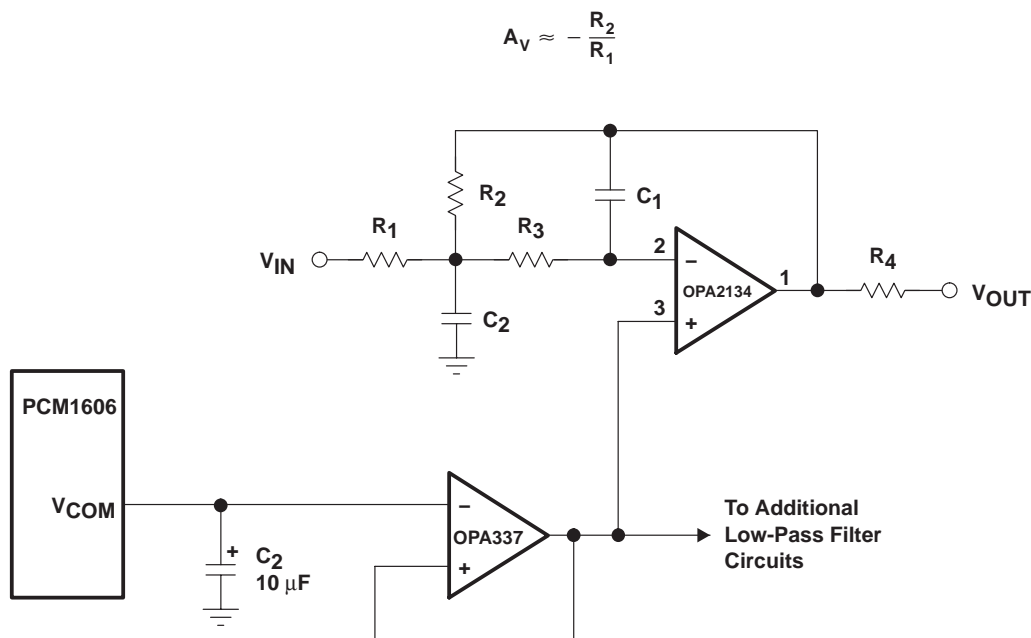

Figure 31. Single-Supply Filter Circuit

APPLICATION INFORMATION

PCB layout guidelines

A typical PCB layout for the PCM1606 is shown in Figure 32. A ground plane is recommended, with the analog and digital sections being isolated from one another using a split or cut in the circuit board. The PCM1606 should be oriented with the digital I/O pins facing the ground plane split/cut to allow for short, direct connections to the digital audio interface and control signals originating from the digital section of the board.

Separate power supplies are recommended for the digital and analog sections of the board. This prevents the switching noise present on the digital supply from contaminating the analog power supply and degrading the dynamic performance of the D/A converters. In cases where a common 5-V supply must be used for the analog and digital sections, an inductance (RF choke, ferrite bead) should be placed between the analog and digital 5-V supply connections to avoid coupling of the digital switching noise into the analog circuitry. Figure 33 shows the recommended approach for single-supply applications.

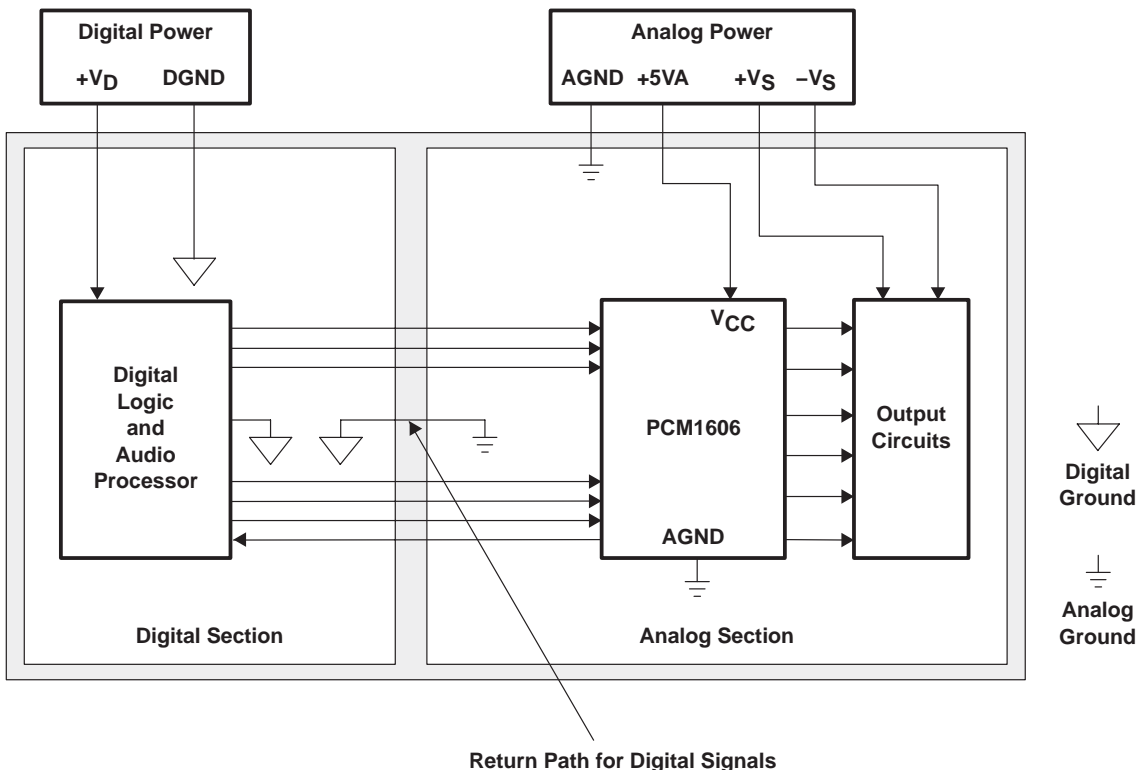

Figure 32. Recommended PCB Layout

## APPLICATION INFORMATION

## PCB layout guidelines (continued)

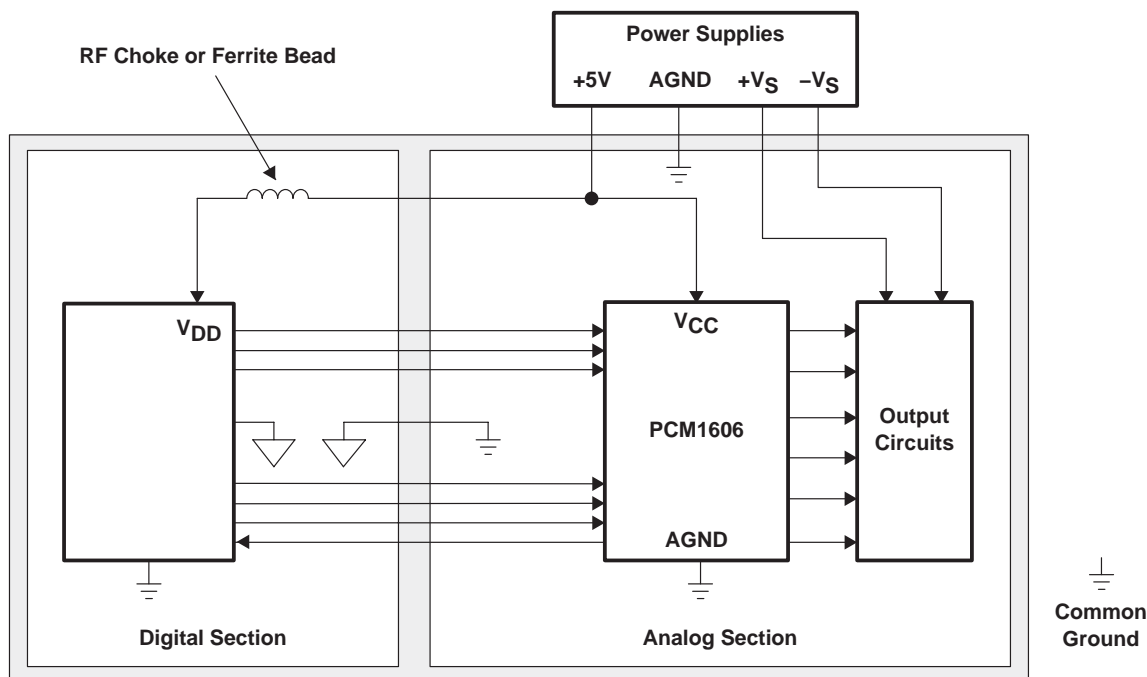

Figure 33. Single-Supply PCB Layout

## key performance parameters measurement

This section provides information on how to measure key dynamic performance parameters for the PCM1606. In all cases, a System Two Cascade Plus by Audio Precision or equivalent audio measurement system is used to perform the testing.

## total harmonic distortion + noise

Total harmonic distortion + noise (THD+N) is a significant figure of merit for audio D/A converters, because it takes into account both harmonic distortion and all noise sources within a specified measurement bandwidth. The true rms value of the distortion and noise is referred to as THD+N.

For the PCM1606 D/A converters, THD+N is measured with a full scale, 1-kHz digital sine wave as the test stimulus at the input of the DAC. The digital generator is set to 24-bit audio word length and a sampling frequency of 44.1 kHz or 96 kHz. The digital generator output is taken from the unbalanced S/PDIF connector of the measurement system. The S/PDIF data is transmitted via coaxial cable to the digital audio receiver on the DEM-DAI1606 demo board. The receiver is then configured to output 24-bit data in either I<sup>2</sup>S or left-justified data format. The DAC audio interface format is programmed to match the receiver output format. The analog output is then taken from the DAC post filter and connected to the analog analyzer input of the measurement system. The analog input is band-limited using filters resident in the analyzer. The resulting THD+N is measured by the analyzer and displayed by the measurement system.

APPLICATION INFORMATION

total harmonic distortion + noise (continued)

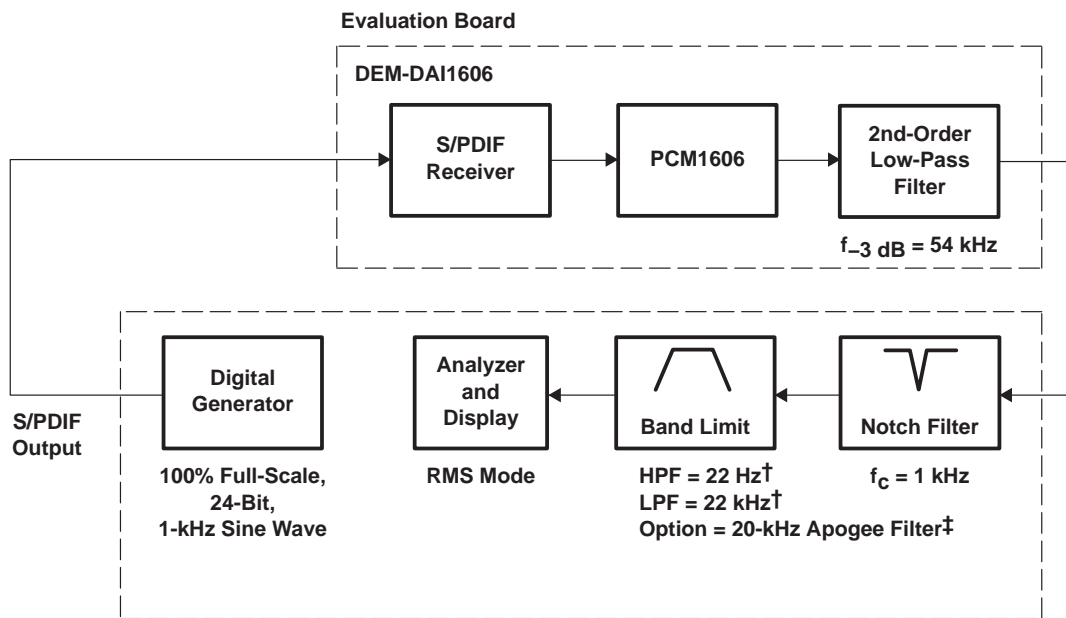

† There is little difference in measured THD+N when using the various settings for these filters..  
 ‡ Required for THD+N test.

Figure 34. Test Setup for THD+N Measurements

dynamic range

Dynamic range is specified as A-weighted, THD+N measured with a -60 dB of full-scale (FS), 1-kHz digital sine wave stimulus at the input of the D/A converter. This measurement is designed to give a good indicator of how the DAC performs given a low-level input signal.

The measurement setup for the dynamic range measurement is shown in Figure 35, and is similar to the THD+N test setup discussed previously. The differences include the band limit filter selection, the additional A-weighting filter, and the -60-dB FS input level.

idle channel signal-to-noise ratio

The signal-to-noise ratio (SNR) test provides a measure of the noise floor of the D/A converter. The input to the D/A is all 0s data. This ensures that the delta-sigma modulator output is connected to the output amplifier circuit so that idle tones (if present) can be observed and affect the SNR measurement. The dither function of the digital generator must also be disabled to ensure an all 0s data stream at the input of the D/A converter.

The measurement setup for SNR is identical to that used for dynamic range, with the exception of the input signal level. (See the note provided in Figure 35).

APPLICATION INFORMATION

idle channel signal-to-noise ratio (continued)

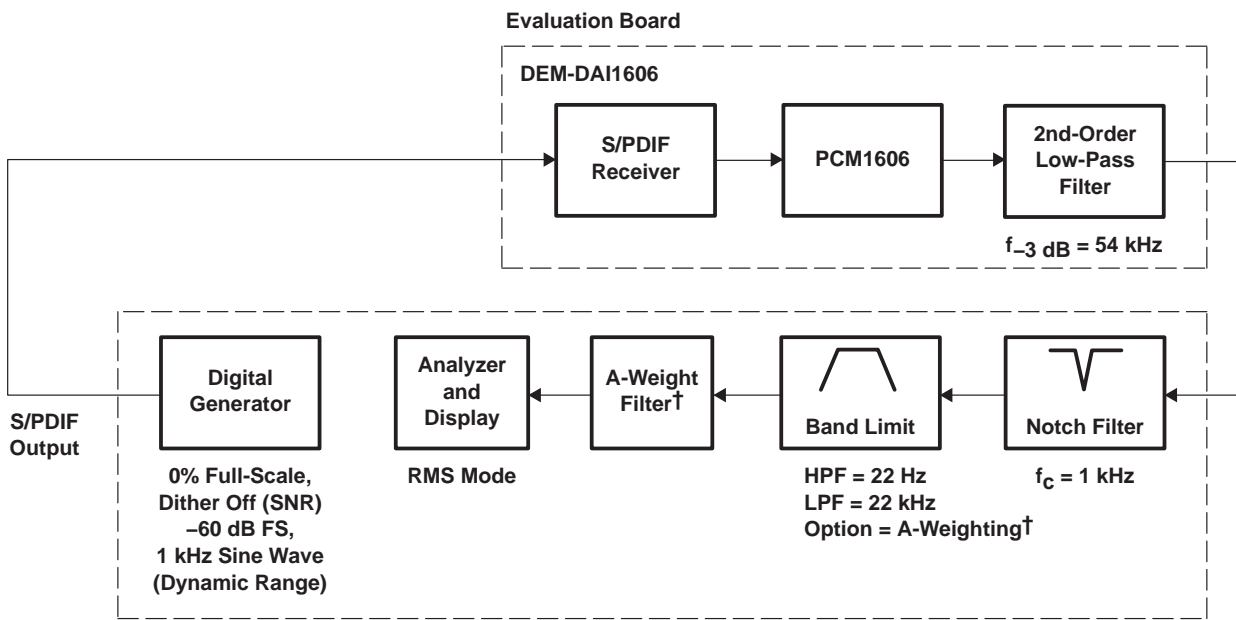

<sup>†</sup> Results without A-Weighting will be approximately 3 dB worse.

Figure 35. Test Setup for Dynamic Range and SNR Measurements

MECHANICAL DATA

DB (R-PDSO-G\*\*)

PLASTIC SMALL-OUTLINE

28 PINS SHOWN

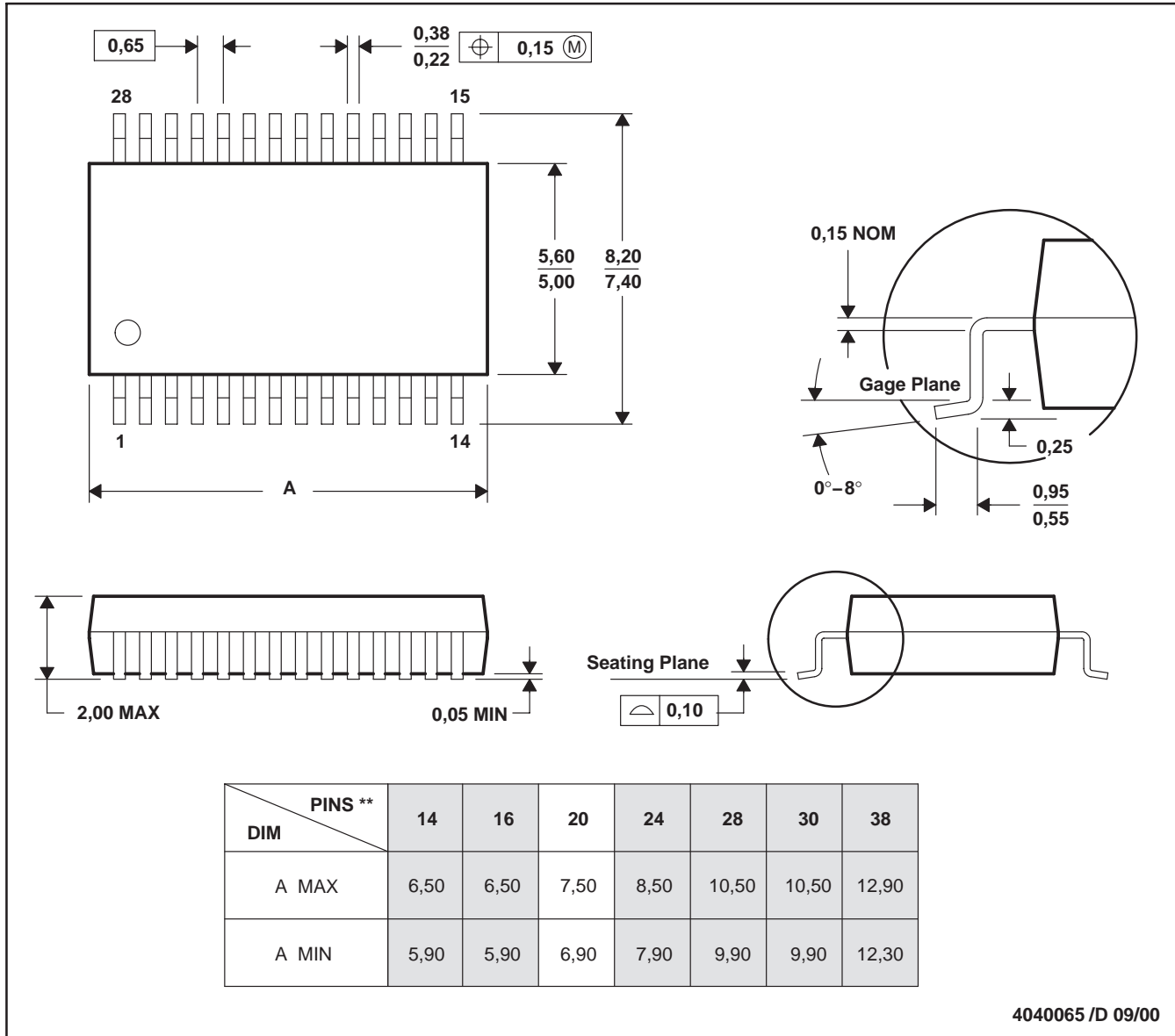

4040065 /D 09/00

- NOTES: A. All linear dimensions are in millimeters.  
 B. This drawing is subject to change without notice.  
 C. Body dimensions do not include mold flash or protrusion not to exceed 0,15 mm.  
 D. Falls within JEDEC MO-150

**PACKAGING INFORMATION**

Orderable Device	Status <sup>(1)</sup>	Package Type	Package Drawing	Pins	Package Qty	Eco Plan <sup>(2)</sup>	Lead/Ball Finish	MSL Peak Temp <sup>(3)</sup>
PCM1606E	ACTIVE	SSOP	DB	20	65	Green (RoHS & no Sb/Br)	CU NIPDAU	Level-1-260C-UNLIM
PCM1606E/2K	ACTIVE	SSOP	DB	20	2000	Green (RoHS & no Sb/Br)	CU NIPDAU	Level-1-260C-UNLIM
PCM1606E/2KG4	ACTIVE	SSOP	DB	20	2000	Green (RoHS & no Sb/Br)	CU NIPDAU	Level-1-260C-UNLIM
PCM1606EG4	ACTIVE	SSOP	DB	20	65	Green (RoHS & no Sb/Br)	CU NIPDAU	Level-1-260C-UNLIM

<sup>(1)</sup> The marketing status values are defined as follows:

**ACTIVE:** Product device recommended for new designs.

**LIFEBUY:** TI has announced that the device will be discontinued, and a lifetime-buy period is in effect.

**NRND:** Not recommended for new designs. Device is in production to support existing customers, but TI does not recommend using this part in a new design.

**PREVIEW:** Device has been announced but is not in production. Samples may or may not be available.

**OBSOLETE:** TI has discontinued the production of the device.

<sup>(2)</sup> Eco Plan - The planned eco-friendly classification: Pb-Free (RoHS), Pb-Free (RoHS Exempt), or Green (RoHS & no Sb/Br) - please check <http://www.ti.com/productcontent> for the latest availability information and additional product content details.

**TBD:** The Pb-Free/Green conversion plan has not been defined.

**Pb-Free (RoHS):** TI's terms "Lead-Free" or "Pb-Free" mean semiconductor products that are compatible with the current RoHS requirements for all 6 substances, including the requirement that lead not exceed 0.1% by weight in homogeneous materials. Where designed to be soldered at high temperatures, TI Pb-Free products are suitable for use in specified lead-free processes.

**Pb-Free (RoHS Exempt):** This component has a RoHS exemption for either 1) lead-based flip-chip solder bumps used between the die and package, or 2) lead-based die adhesive used between the die and leadframe. The component is otherwise considered Pb-Free (RoHS compatible) as defined above.

**Green (RoHS & no Sb/Br):** TI defines "Green" to mean Pb-Free (RoHS compatible), and free of Bromine (Br) and Antimony (Sb) based flame retardants (Br or Sb do not exceed 0.1% by weight in homogeneous material)

<sup>(3)</sup> MSL, Peak Temp. -- The Moisture Sensitivity Level rating according to the JEDEC industry standard classifications, and peak solder temperature.

**Important Information and Disclaimer:** The information provided on this page represents TI's knowledge and belief as of the date that it is provided. TI bases its knowledge and belief on information provided by third parties, and makes no representation or warranty as to the accuracy of such information. Efforts are underway to better integrate information from third parties. TI has taken and continues to take reasonable steps to provide representative and accurate information but may not have conducted destructive testing or chemical analysis on incoming materials and chemicals. TI and TI suppliers consider certain information to be proprietary, and thus CAS numbers and other limited information may not be available for release.

In no event shall TI's liability arising out of such information exceed the total purchase price of the TI part(s) at issue in this document sold by TI to Customer on an annual basis.

## IMPORTANT NOTICE

Texas Instruments Incorporated and its subsidiaries (TI) reserve the right to make corrections, modifications, enhancements, improvements, and other changes to its products and services at any time and to discontinue any product or service without notice. Customers should obtain the latest relevant information before placing orders and should verify that such information is current and complete. All products are sold subject to TI's terms and conditions of sale supplied at the time of order acknowledgment.

TI warrants performance of its hardware products to the specifications applicable at the time of sale in accordance with TI's standard warranty. Testing and other quality control techniques are used to the extent TI deems necessary to support this warranty. Except where mandated by government requirements, testing of all parameters of each product is not necessarily performed.

TI assumes no liability for applications assistance or customer product design. Customers are responsible for their products and applications using TI components. To minimize the risks associated with customer products and applications, customers should provide adequate design and operating safeguards.

TI does not warrant or represent that any license, either express or implied, is granted under any TI patent right, copyright, mask work right, or other TI intellectual property right relating to any combination, machine, or process in which TI products or services are used. Information published by TI regarding third-party products or services does not constitute a license from TI to use such products or services or a warranty or endorsement thereof. Use of such information may require a license from a third party under the patents or other intellectual property of the third party, or a license from TI under the patents or other intellectual property of TI.

Reproduction of TI information in TI data books or data sheets is permissible only if reproduction is without alteration and is accompanied by all associated warranties, conditions, limitations, and notices. Reproduction of this information with alteration is an unfair and deceptive business practice. TI is not responsible or liable for such altered documentation. Information of third parties may be subject to additional restrictions.

Resale of TI products or services with statements different from or beyond the parameters stated by TI for that product or service voids all express and any implied warranties for the associated TI product or service and is an unfair and deceptive business practice. TI is not responsible or liable for any such statements.

TI products are not authorized for use in safety-critical applications (such as life support) where a failure of the TI product would reasonably be expected to cause severe personal injury or death, unless officers of the parties have executed an agreement specifically governing such use. Buyers represent that they have all necessary expertise in the safety and regulatory ramifications of their applications, and acknowledge and agree that they are solely responsible for all legal, regulatory and safety-related requirements concerning their products and any use of TI products in such safety-critical applications, notwithstanding any applications-related information or support that may be provided by TI. Further, Buyers must fully indemnify TI and its representatives against any damages arising out of the use of TI products in such safety-critical applications.

TI products are neither designed nor intended for use in military/aerospace applications or environments unless the TI products are specifically designated by TI as military-grade or "enhanced plastic." Only products designated by TI as military-grade meet military specifications. Buyers acknowledge and agree that any such use of TI products which TI has not designated as military-grade is solely at the Buyer's risk, and that they are solely responsible for compliance with all legal and regulatory requirements in connection with such use.

TI products are neither designed nor intended for use in automotive applications or environments unless the specific TI products are designated by TI as compliant with ISO/TS 16949 requirements. Buyers acknowledge and agree that, if they use any non-designated products in automotive applications, TI will not be responsible for any failure to meet such requirements.

Following are URLs where you can obtain information on other Texas Instruments products and application solutions:

### Products

Amplifiers	<a href="http://amplifier.ti.com">amplifier.ti.com</a>
Data Converters	<a href="http://dataconverter.ti.com">dataconverter.ti.com</a>
DLP® Products	<a href="http://www.dlp.com">www.dlp.com</a>
DSP	<a href="http://dsp.ti.com">dsp.ti.com</a>
Clocks and Timers	<a href="http://www.ti.com/clocks">www.ti.com/clocks</a>
Interface	<a href="http://interface.ti.com">interface.ti.com</a>
Logic	<a href="http://logic.ti.com">logic.ti.com</a>
Power Mgmt	<a href="http://power.ti.com">power.ti.com</a>
Microcontrollers	<a href="http://microcontroller.ti.com">microcontroller.ti.com</a>
RFID	<a href="http://www.ti-rfid.com">www.ti-rfid.com</a>
RF/IF and ZigBee® Solutions	<a href="http://www.ti.com/lprf">www.ti.com/lprf</a>

### Applications

Audio	<a href="http://www.ti.com/audio">www.ti.com/audio</a>
Automotive	<a href="http://www.ti.com/automotive">www.ti.com/automotive</a>
Broadband	<a href="http://www.ti.com/broadband">www.ti.com/broadband</a>
Digital Control	<a href="http://www.ti.com/digitalcontrol">www.ti.com/digitalcontrol</a>
Medical	<a href="http://www.ti.com/medical">www.ti.com/medical</a>
Military	<a href="http://www.ti.com/military">www.ti.com/military</a>
Optical Networking	<a href="http://www.ti.com/opticalnetwork">www.ti.com/opticalnetwork</a>
Security	<a href="http://www.ti.com/security">www.ti.com/security</a>
Telephony	<a href="http://www.ti.com/telephony">www.ti.com/telephony</a>
Video & Imaging	<a href="http://www.ti.com/video">www.ti.com/video</a>
Wireless	<a href="http://www.ti.com/wireless">www.ti.com/wireless</a>

Mailing Address: Texas Instruments, Post Office Box 655303, Dallas, Texas 75265  
Copyright © 2009, Texas Instruments Incorporated

## Looking for pricing, stock, or lifecycle information?

Click below to explore more details on WIN SOURCE:

 [View PCM1606EG](#) on WIN SOURCE

 [Texas Instruments](#) Information

## Optimize Your Supply Chain with WIN SOURCE Solutions

-  Global Sourcing Solution
-  Obsolete Management
-  Cost Control Management
-  Shortage Management
-  Alternative Solution
-  Excess Inventory Management