



**THE DATASHEET OF  
PCM1716E/2K**





PCM1716

# SoundPLUS™ 24-Bit, 96kHz Sampling CMOS Delta-Sigma Stereo Audio DIGITAL-TO-ANALOG CONVERTER

## FEATURES

- ENHANCED MULTI-LEVEL DELTA-SIGMA DAC
- SAMPLING FREQUENCY ( $f_s$ ): 16kHz - 96kHz
- INPUT AUDIO DATA WORD: 16-, 20-, 24-Bit
- HIGH PERFORMANCE: THD+N: -96dB  
Dynamic Range: 106dB  
SNR: 106dB  
Analog Output Range:  $0.62 \times V_{CC}$  (Vp-p)
- 8x OVERSAMPLING DIGITAL FILTER: Stop Band Attenuation: -82dB  
Passband Ripple:  $\pm 0.002$ dB  
Slow Roll Off
- MULTI FUNCTIONS: Digital De-emphasis  
L/R Independent Digital Attenuation  
Soft Mute  
Zero Detect Mute  
Zero Flag  
Chip Select  
Reversible Output Phase
- +5V SINGLE SUPPLY OPERATION
- SMALL 28-LEAD SSOP PACKAGE

## DESCRIPTION

The PCM1716 is designed for Mid to High grade Digital Audio applications which achieve 96kHz sampling rates with 24-bit audio data. PCM1716 uses a newly developed, enhanced multi-level delta-sigma modulator architecture that improves audio dynamic performance and reduces jitter sensitivity in actual applications.

The internal digital filter operates at 8x over sampling at a 96kHz sampling rate, with two kinds of roll-off performances that can be selected: sharp roll-off, or slow roll-off, as required for specific applications.

PCM1716 is suitable for Mid to High grade audio applications such as CD, DVD-Audio, and Music Instruments, since the device has superior audio dynamic performance, 24-bit resolution and 96kHz sampling.

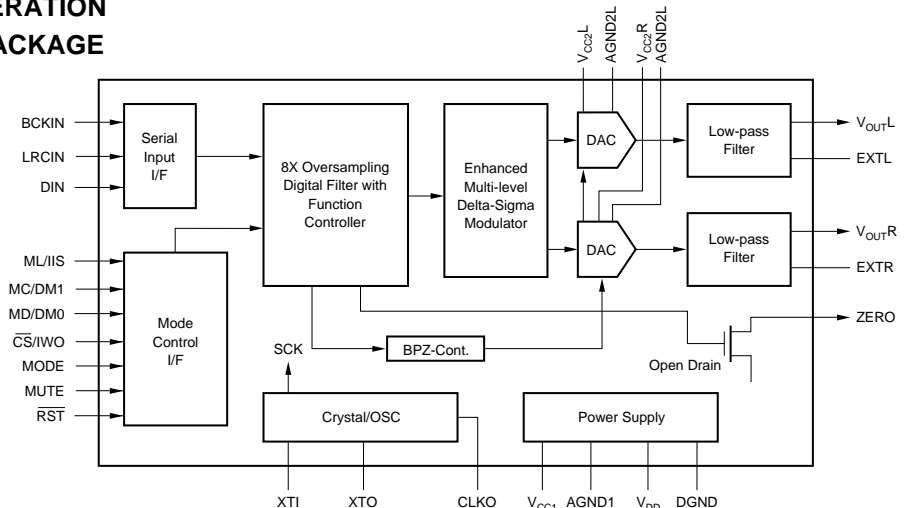

International Airport Industrial Park • Mailing Address: PO Box 11400, Tucson, AZ 85734 • Street Address: 6730 S. Tucson Blvd., Tucson, AZ 85706 • Tel: (520) 746-1111 • Twx: 910-952-1111  
Internet: <http://www.burr-brown.com/> • FAXLine: (800) 548-6133 (US/Canada Only) • Cable: BBRCORP • Telex: 066-6491 • FAX: (520) 889-1510 • Immediate Product Info: (800) 548-6132

# SPECIFICATIONS

All specifications at +25°C, +V<sub>CC</sub> = +V<sub>DD</sub> = +5V, f<sub>S</sub> = 44.1kHz, and 24-bit input data, SYSCLK = 384f<sub>S</sub>, unless otherwise noted.

PARAMETER	CONDITIONS	PCM1716			UNITS
		MIN	TYP	MAX	
<b>RESOLUTION</b>			24		Bits
<b>DATA FORMAT</b> Audio Data Interface Format Data Bit Length Audio Data Format Sampling Frequency (f <sub>S</sub> ) System Clock Frequency <sup>(1)</sup>		16	Standard/I <sup>2</sup> S 16/20/24 Selectable MSB First, 2's Comp 256/384/512/768f <sub>S</sub>	96	kHz
<b>DIGITAL INPUT/OUTPUT LOGIC LEVEL</b> Input Logic Level Output Logic Level (CLKO)	V <sub>IH</sub> V <sub>IL</sub> V <sub>OH</sub> V <sub>OL</sub> I <sub>OH</sub> = 2mA I <sub>OL</sub> = 4mA	2.0 4.5		0.8 0.5	V V V V
<b>CLKO PERFORMANCE<sup>(2)</sup></b> Output Rise Time Output Fall Time Output Duty Cycle	20 ~ 80% V <sub>DD</sub> , 10pF 80 ~ 20% V <sub>DD</sub> , 10pF 10pF Load		5.5 4 37		ns ns %
<b>DYNAMIC PERFORMANCE<sup>(3)</sup> (24-Bit Data)</b> THD+N Dynamic Range Signal-to-Noise Ratio <sup>(4)</sup> Channel Separation	V <sub>O</sub> = 0dB V <sub>O</sub> = -60dB f <sub>S</sub> = 44.1kHz f <sub>S</sub> = 96kHz f <sub>S</sub> = 44.1kHz f <sub>S</sub> = 44.1kHz EIAJ A-weighted f <sub>S</sub> = 96kHz A-weighted f <sub>S</sub> = 44.1kHz EIAJ A-weighted f <sub>S</sub> = 96kHz A-weighted f <sub>S</sub> = 44.1kHz f <sub>S</sub> = 96kHz		-97 -94 -42 106 103 106 103 102 101	-90	dB dB dB dB dB dB dB dB dB
<b>DYNAMIC PERFORMANCE<sup>(3)</sup> (16-Bit Data)</b> THD+N Dynamic Range	V <sub>O</sub> = 0dB f <sub>S</sub> = 44.1kHz f <sub>S</sub> = 96kHz f <sub>S</sub> = 44.1kHz EIAJ A-weighted f <sub>S</sub> = 96kHz A-weighted		-94 -92 98 97		dB dB dB dB
<b>DC ACCURACY</b> Gain Error Gain Mismatch: Channel-to-Channel Bipolar Zero Error	V <sub>O</sub> = 0.5V <sub>CC</sub> at Bipolar Zero		±1.0 ±1.0 ±30	±3.0 ±3.0 ±60	% of FSR % of FSR mV
<b>ANALOG OUTPUT</b> Output Voltage Center Voltage Load Impedance	Full Scale (0dB) AC Load		0.62 V <sub>CC</sub> 0.5 V <sub>CC</sub> 5		V <sub>p-p</sub> V kΩ
<b>DIGITAL FILTER PERFORMANCE</b> Filter Characteristics 1 (Sharp Roll-Off) Passband Stopband Passband Ripple Stopband Attenuation Filter Characteristics 2 (Slow Roll-Off) Passband Stopband Passband Ripple Stopband Attenuation Delay Time De-emphasis Error	±0.002dB -3dB Stop Band = 0.546f <sub>S</sub> Stop Band = 0.567f <sub>S</sub> ±0.002dB -3dB Stopband = 0.732f <sub>S</sub>	0.546f <sub>S</sub>		0.454f <sub>S</sub> 0.490f <sub>S</sub> ±0.002 0.274f <sub>S</sub> 0.454f <sub>S</sub> ±0.002 30/f <sub>S</sub> ±0.1	dB dB dB dB dB dB sec dB
<b>INTERNAL ANALOG FILTER</b> -3dB Bandwidth Passband Response	f = 20kHz		100 -0.16		kHz dB
<b>POWER SUPPLY REQUIREMENTS</b> Voltage Range Supply Current: I <sub>CC</sub> + I <sub>DD</sub> Power Dissipation	V <sub>DD</sub> , V <sub>CC</sub> f <sub>S</sub> = 44.1kHz f <sub>S</sub> = 96kHz f <sub>S</sub> = 44.1kHz f <sub>S</sub> = 96kHz	4.5	5 32 45 160 225	5.5 45 225	VDC mA mA mW mW
<b>TEMPERATURE RANGE</b> Operation Storage		-25 -55		+85 +100	°C °C

NOTES: (1) Refer section of system clock. (2) External buffer is recommended. (3) Dynamic performance specs are tested with 20kHz low pass filter and THD+N specs are tested with 30kHz LPF, 400Hz HPF, Average Mode. (4) SNR is tested at internally infinity zero detection off.

## PIN CONFIGURATION

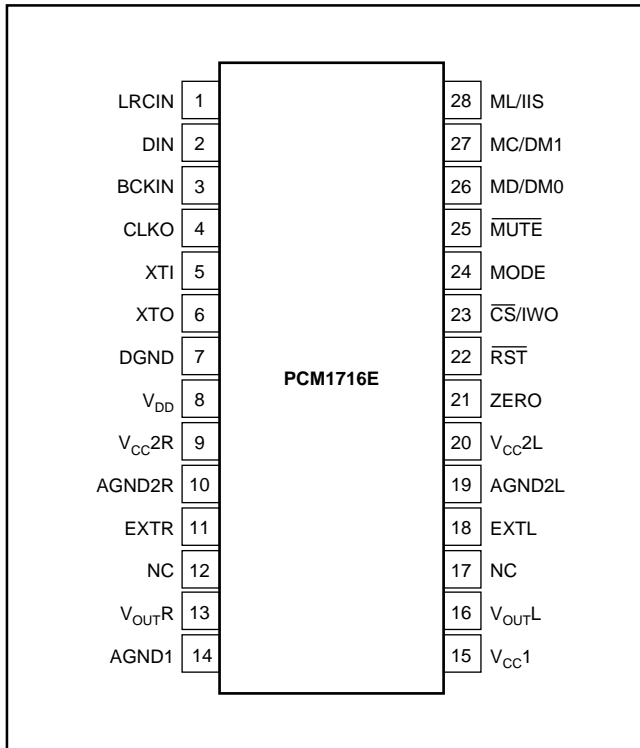

## PACKAGE INFORMATION

PRODUCT	PACKAGE	PACKAGE DRAWING NUMBER <sup>(1)</sup>
PCM1716E	28-Pin SSOP	324

NOTE: (1) For detailed drawing and dimension table, please see end of data sheet, or Appendix C of Burr-Brown IC Data Book.

## ABSOLUTE MAXIMUM RATINGS

Power Supply Voltage	+6.5V
+V <sub>CC</sub> to +V <sub>DD</sub> Difference	±0.1V
Input Logic Voltage	-0.3V to (V <sub>DD</sub> + 0.3V)
Input Current (except power supply)	±10mA
Power Dissipation	400mW
Operating Temperature Range	-25°C to +85°C
Storage Temperature	-55°C to +125°C
Lead Temperature (soldering, 5s)	+260°C

## PIN ASSIGNMENTS

PIN	NAME	I/O	DESCRIPTION
1	LRCIN	IN	Left and Right Clock Input. This clock is equal to the sampling rate - $f_s$ . <sup>(1)</sup>
2	DIN	IN	Serial Audio Data Input <sup>(1)</sup>
3	BCKIN	IN	Bit Clock Input for Serial Audio Data. <sup>(1)</sup>
4	CLKO	OUT	Buffered Output of Oscillator. Equivalent to System Clock.
5	XTI	IN	Oscillator Input (External Clock Input)
6	XTO	OUT	Oscillator Output
7	DGND	—	Digital Ground
8	V <sub>DD</sub>	—	Digital Power +5V
9	V <sub>CC2R</sub>	—	Analog Power +5V
10	AGND2R	—	Analog Ground
11	EXTR	OUT	Rch, Common Pin of Analog Output Amp
12	NC	—	No Connection
13	V <sub>OUTR</sub>	OUT	Rch, Analog Voltage Output of Audio Signal
14	AGND1	—	Analog Ground
15	V <sub>CC1</sub>	—	Analog Power +5V
16	V <sub>OUTL</sub>	OUT	Lch, Analog Voltage Output of Audio Signal
17	NC	—	No Connection
18	EXTL	OUT	Lch, Common Pin of Analog Output Amp
19	AGND2L	—	Analog Ground
20	V <sub>CC2L</sub>	—	Analog Power +5V
21	ZERO	OUT	Zero Data Flag
22	RST	IN	Reset. When this pin is low, the DF and modulators are held in reset. <sup>(2)</sup>
23	CS/IWO	IN	Chip Select/Input Format Selection. When this pin is low, the Mode Control is effective. <sup>(3)</sup>
24	MODE	IN	Mode Control Select. (H: Software, L: Hardware) <sup>(2)</sup>
25	MUTE	IN	Mute Control
26	MD/DM0	IN	Mode Control, DATA/De-emphasis Selection 1 <sup>(2)</sup>
27	MC/DM1	IN	Mode Control, BCK/De-emphasis Selection 2 <sup>(2)</sup>
28	ML/I <sup>2</sup> S	IN	Mode Control, WDCK/Input Format Selection <sup>(2)</sup>

NOTES: (1) Pins 1, 2, 3; Schmitt Trigger input. (2) Pins 22, 24, 25, 26, 27, 28; Schmitt Trigger input with pull-up resistor. (3) Pin 23; Schmitt Trigger input with pull-down resistor.



## ELECTROSTATIC DISCHARGE SENSITIVITY

This integrated circuit can be damaged by ESD. Burr-Brown recommends that all integrated circuits be handled with appropriate precautions. Failure to observe proper handling and installation procedures can cause damage.

ESD damage can range from subtle performance degradation to complete device failure. Precision integrated circuits may be more susceptible to damage because very small parametric changes could cause the device not to meet its published specifications.

The information provided herein is believed to be reliable; however, BURR-BROWN assumes no responsibility for inaccuracies or omissions. BURR-BROWN assumes no responsibility for the use of this information, and all use of such information shall be entirely at the user's own risk. Prices and specifications are subject to change without notice. No patent rights or licenses to any of the circuits described herein are implied or granted to any third party. BURR-BROWN does not authorize or warrant any BURR-BROWN product for use in life support devices and/or systems.

# TYPICAL PERFORMANCE CURVES

All specifications at +25°C, +V<sub>CC</sub> = +V<sub>DD</sub> = +5V, f<sub>S</sub> = 44.1kHz, and 24-bit input data, SYSCLK = 384f<sub>S</sub>, unless otherwise noted.

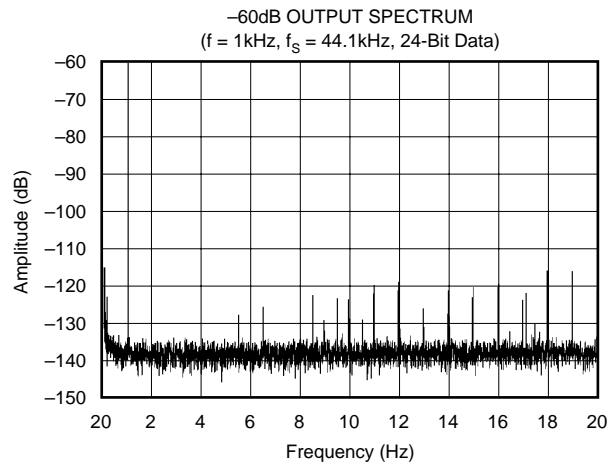
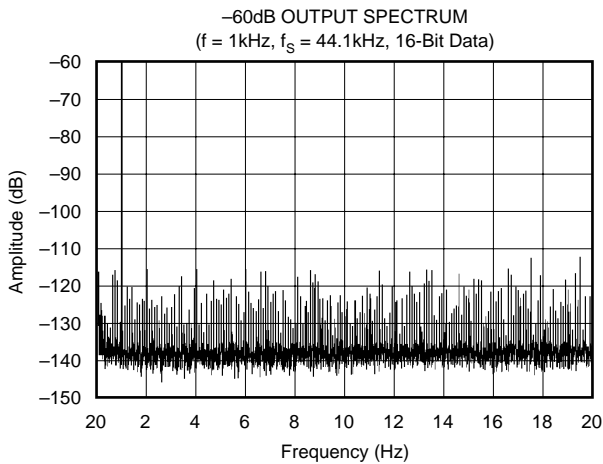
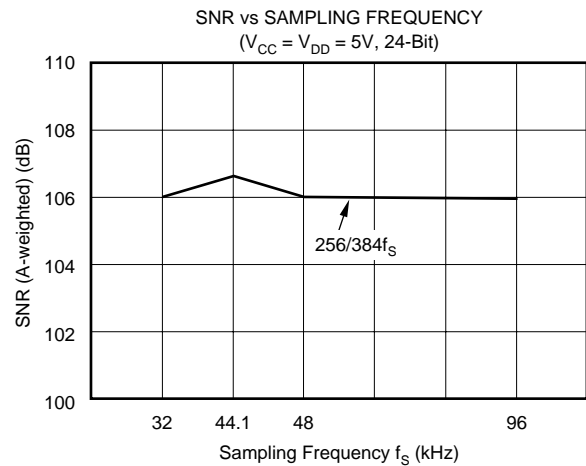
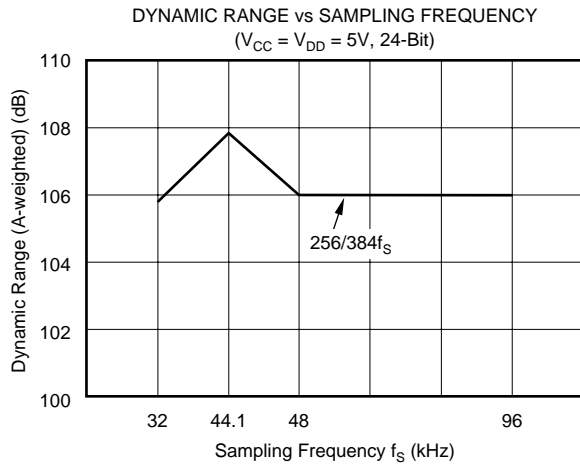
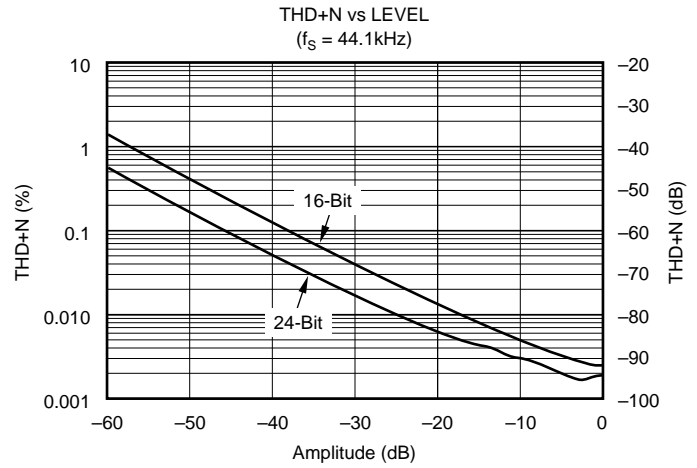
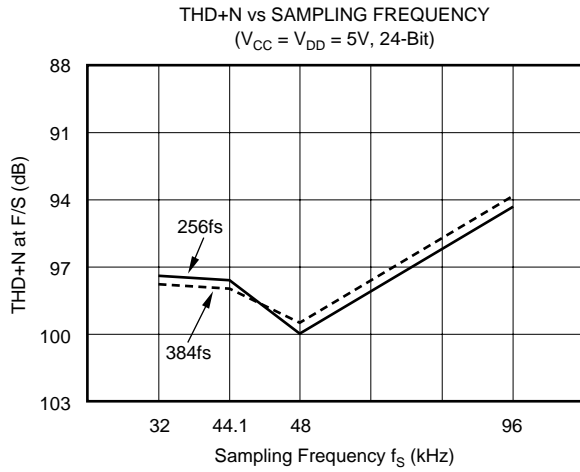

# TYPICAL PERFORMANCE CURVES (CONT)

OVERALL FREQUENCY CHARACTERISTIC  
(Sharp Roll-Off)

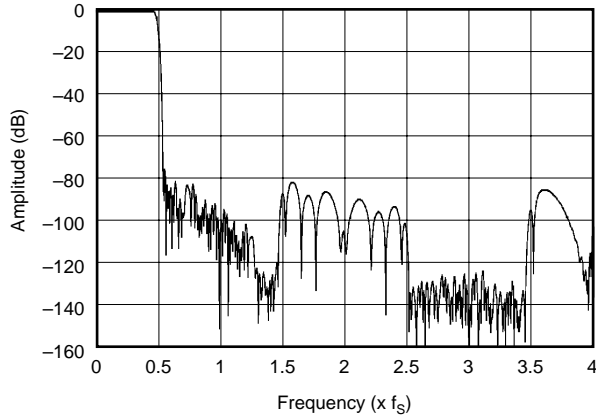

PASSBAND RIPPLE CHARACTERISTIC  
(Sharp Roll-Off)

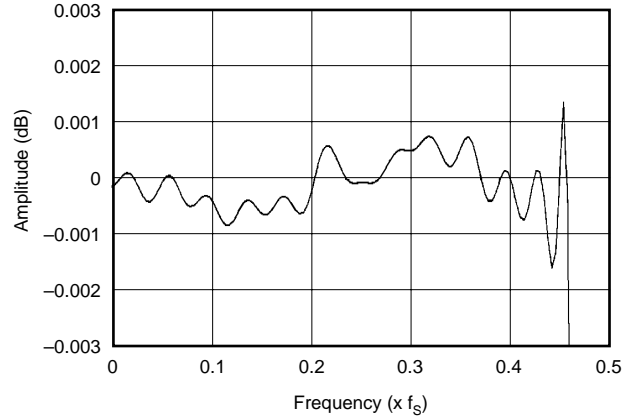

OVERALL FREQUENCY CHARACTERISTIC  
(Slow Roll-Off)

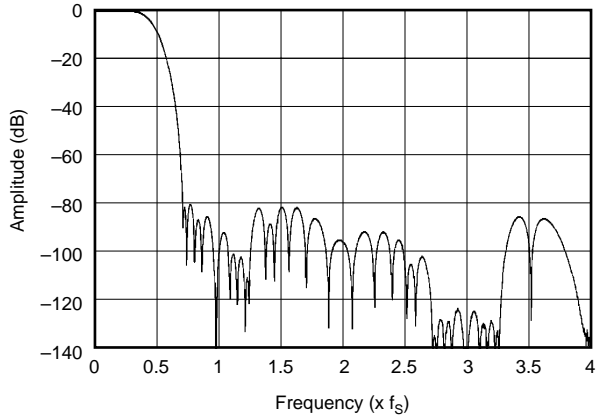

FREQUENCY CHARACTERISTIC  
(Slow Roll-Off)

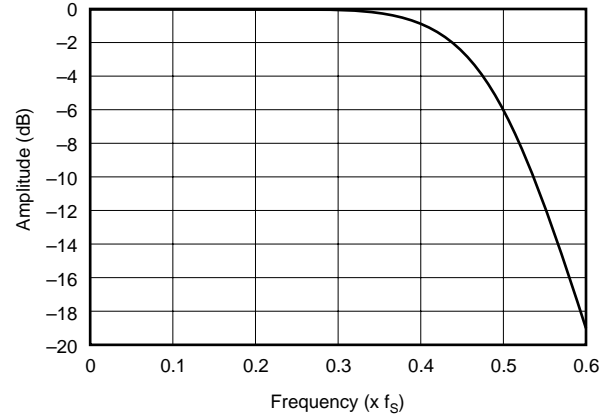

DE-EMPHASIS FREQUENCY RESPONSE ( $f_s = 32\text{kHz}$ )

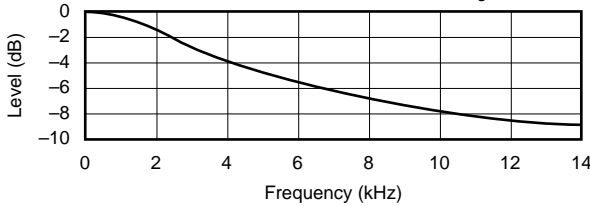

DE-EMPHASIS ERROR ( $f_s = 32\text{kHz}$ )

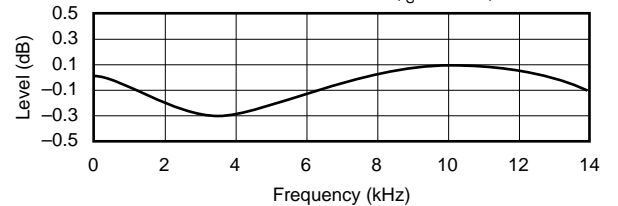

DE-EMPHASIS FREQUENCY RESPONSE ( $f_s = 44.1\text{kHz}$ )

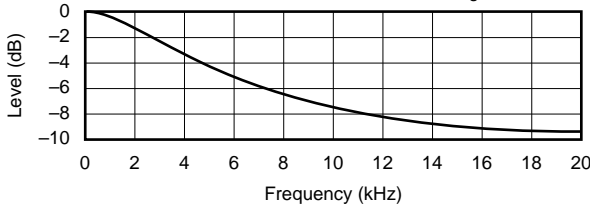

DE-EMPHASIS ERROR ( $f_s = 44.1\text{kHz}$ )

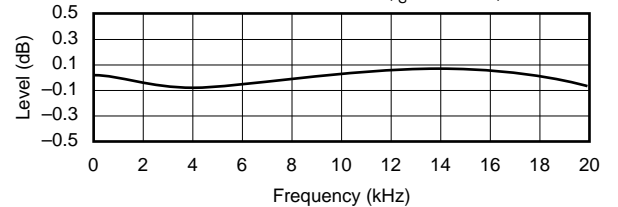

DE-EMPHASIS FREQUENCY RESPONSE ( $f_s = 48\text{kHz}$ )

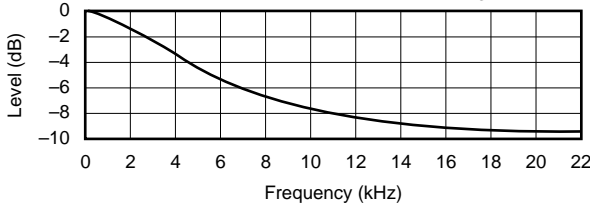

DE-EMPHASIS ERROR ( $f_s = 48\text{kHz}$ )

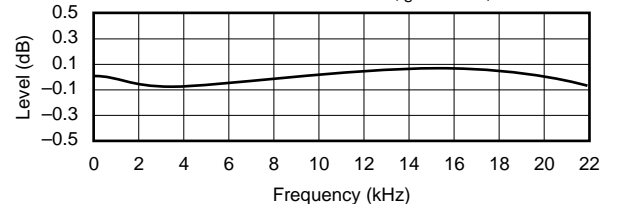

## SYSTEM CLOCK

The system clock for PCM1716 must be either  $256f_s$ ,  $384f_s$ ,  $512f_s$  or  $768f_s$ , where  $f_s$  is the audio sampling frequency (typically 32kHz, 44.1kHz, 48kHz, or 96kHz). But  $768f_s$  at 96kHz is not accepted.

The system clock can be either a crystal oscillator placed between XTI (pin 5) and XTO (pin 6), or an external clock input to XTI. If an external system clock is used, XTO is open (floating). Figure 1 illustrates the typical system clock connections.

PCM1716 has a system clock detection circuit which automatically senses if the system clock is operating at  $256f_s \sim 768f_s$ . The system clock should be synchronized with LRCIN (pin 1) clock. LRCIN (left-right clock) operates at the sampling frequency  $f_s$ . In the event these clocks are not synchronized, PCM1716 can compensate for the phase difference internally. If the phase difference between left-right and system clocks is greater than 6-bit clocks (BCKIN), the synchronization is performed internally. While the synchronization is processing, the analog output is forced to a DC level at bipolar zero. The synchronization typically occurs in less than 1 cycle of LRCIN.

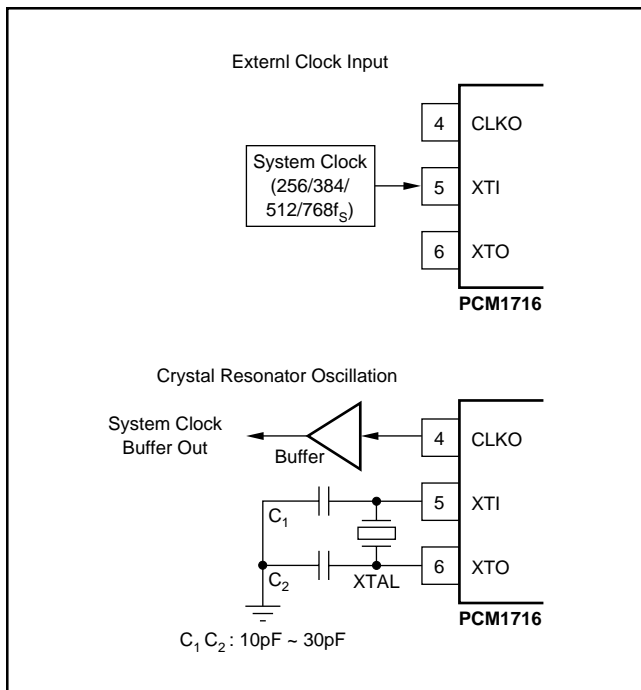

FIGURE 1. System Clock Connection.

Typical input system clock frequencies to the PCM1716 are shown in Table I, also, external input clock timing requirements are shown in Figure 2.

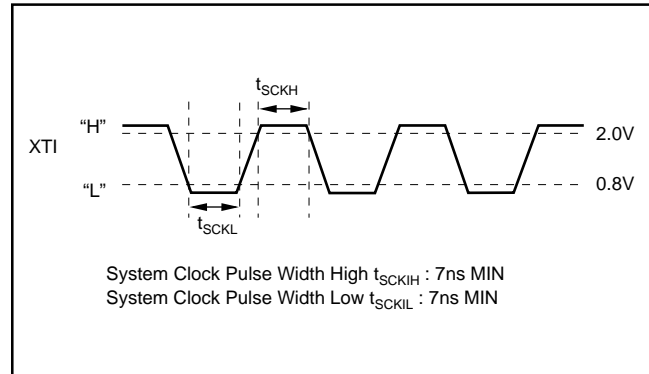

FIGURE 2. XTI Clock Timing.

## DATA INTERFACE FORMATS

Digital audio data is interfaced to PCM1716 on pins 1, 2, and 3, LRCIN (left-right clock), DIN (data input) and BCKIN (bit clock). PCM1716 can accept both standard, I<sup>2</sup>S, and left justified data formats.

Figure 3 illustrates acceptable input data formats. Figure 4 shows required timing specification for digital audio data.

## Reset

PCM1716 has both internal power-on reset circuit and the  $\overline{RST}$  pin (pin 22) which accepts an external forced reset by  $\overline{RST} = \text{LOW}$ . For internal power on reset, initialize (reset) is done automatically at power on  $V_{DD} > 2.2\text{V}$  (typ). During internal reset = LOW, the output of the DAC is invalid and the analog outputs are forced to  $V_{CC}/2$ . Figure 5 illustrates the timing of the internal power on reset.

PCM1716 accepts an external forced reset when  $\overline{RST} = \text{L}$ . When  $\overline{RST} = \text{L}$ , the output of the DAC is invalid and the analog outputs are forced to  $V_{CC}/2$  after internal initialization (1024 system clocks count after  $\overline{RST} = \text{H}$ .) Figure 6 illustrates the timing of the  $\overline{RST}$  pin.

## Zero Out (pin 21)

If the input data is continuously zero for 65536 cycles of BCK, an internal FET is switched to "ON". The drain of the internal FET is the zero-pin, it will enable "wired-or" with external circuit. This zero detect function is available in both software mode and hardware mode.

SAMPLING RATE FREQUENCY ( $f_s$ ) - LRCIN	SYSTEM CLOCK FREQUENCY - MHz			
	256 $f_s$	384 $f_s$	512 $f_s$	768 $f_s$
32kHz	8.1920	12.2880	16.3840	24.5760
44.1kHz	11.2896	16.9340	22.5792	33.8688 <sup>(1)</sup>
48kHz	12.2880	18.4320	24.5760	36.8640 <sup>(1)</sup>
96kHz	24.5760	36.8640 <sup>(1)</sup>	49.1520 <sup>(1)</sup>	—

NOTE: (1) The Internal Crystal oscillator frequency cannot be larger than 24.576MHz.

TABLE I. Typical System Clock Frequency.

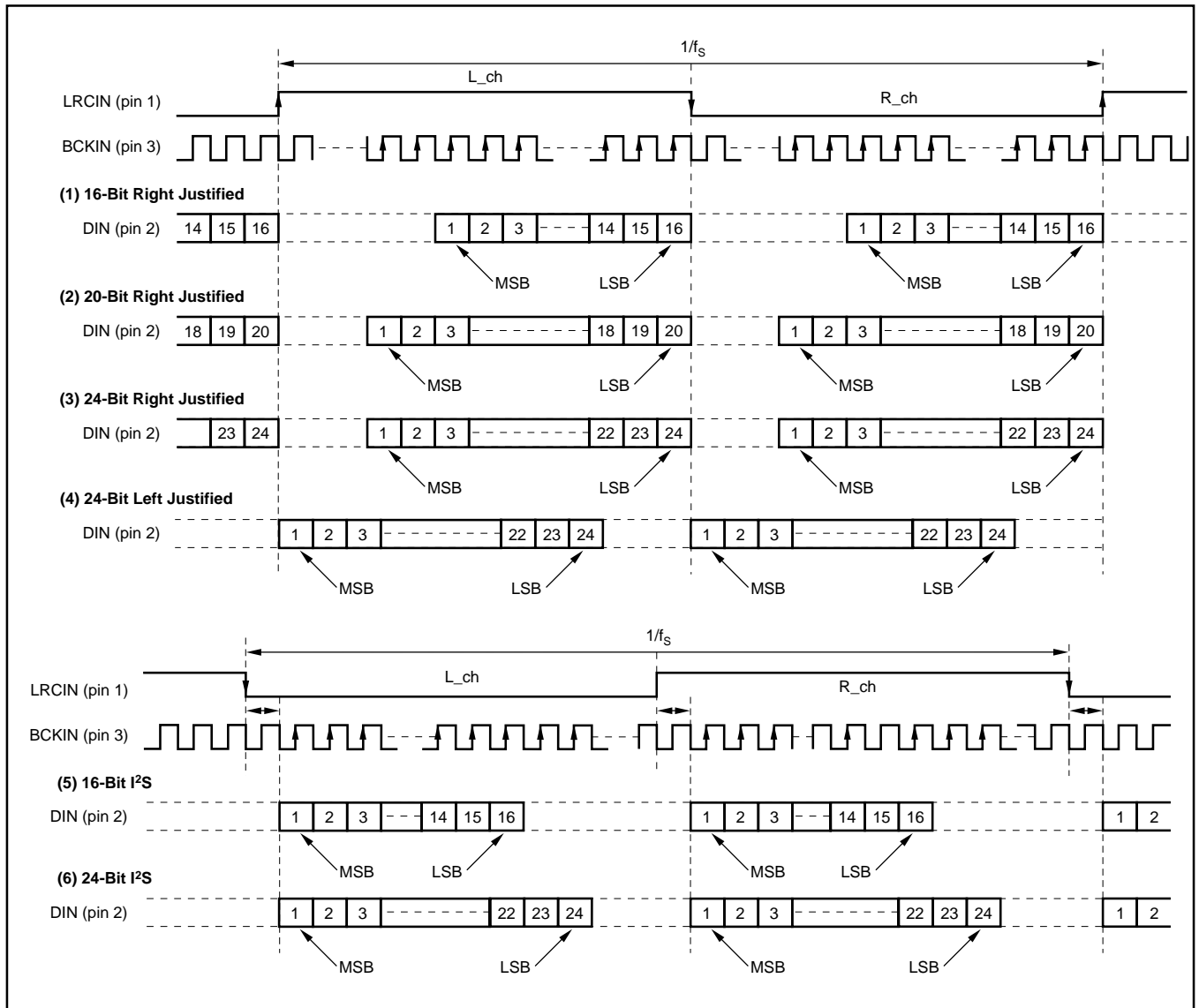

FIGURE 3. Audio Data Input Formats.

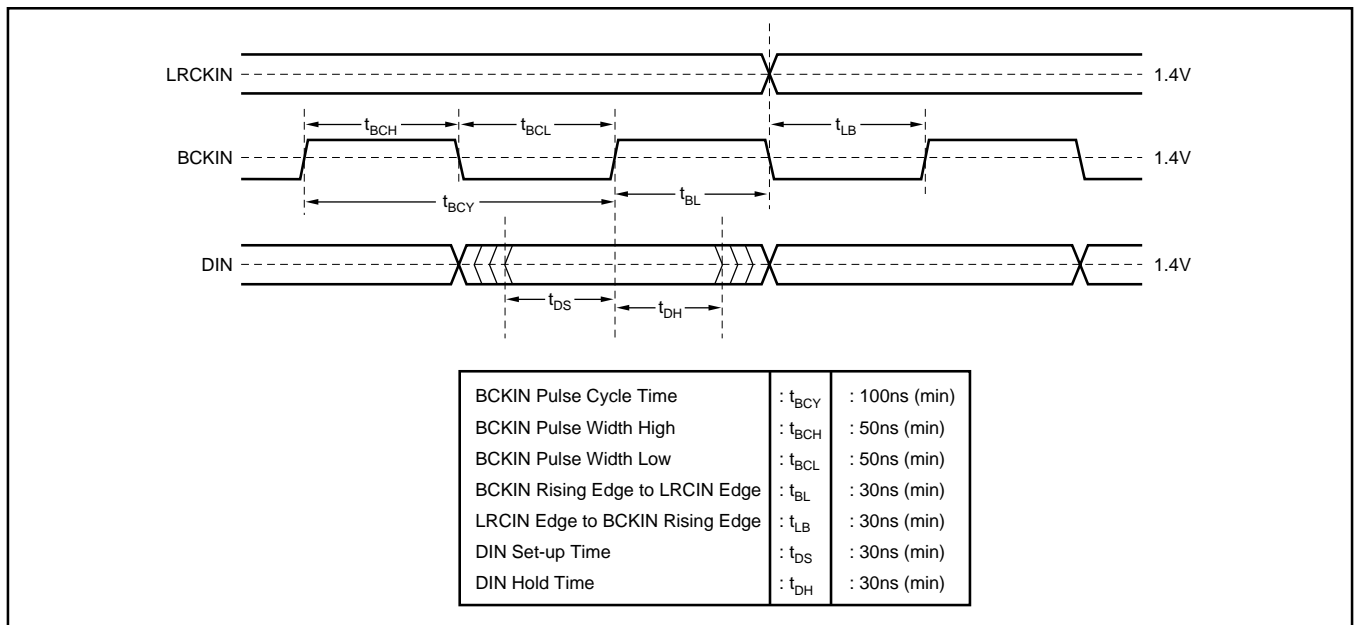

FIGURE 4. Audio Data Input Timing Specification.

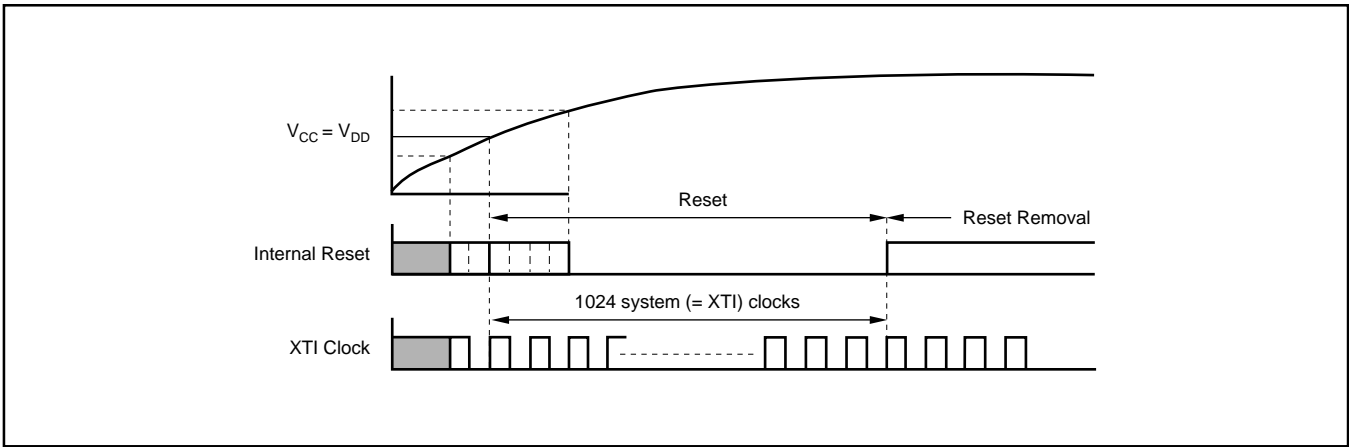

FIGURE 5. Internal Power-On Reset Timing.

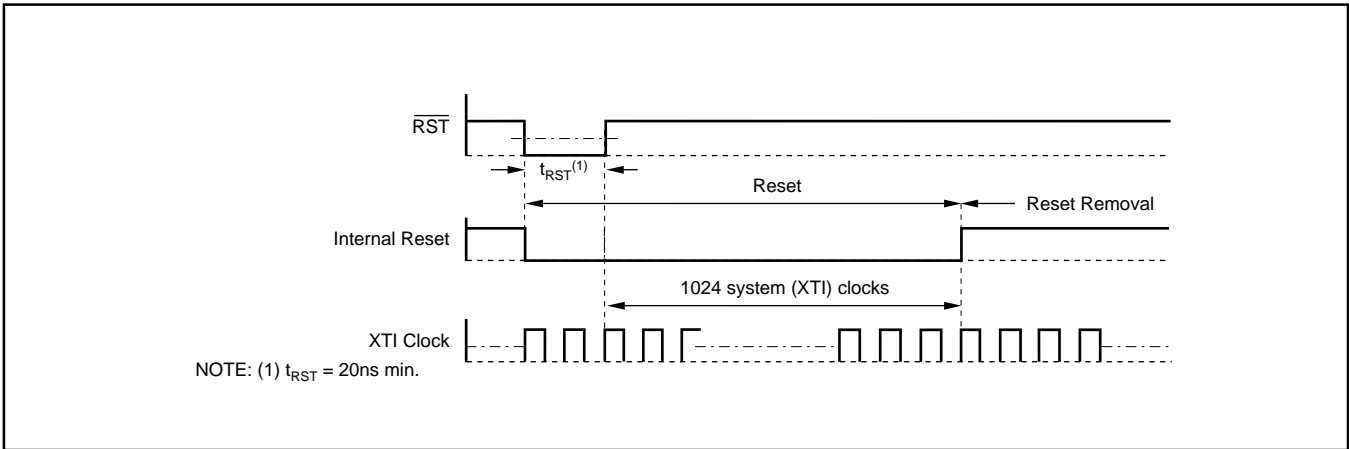

FIGURE 6. External Forced Reset Timing.

## FUNCTIONAL DESCRIPTION

PCM1716 has several built-in functions including digital attenuation, digital de-emphasis, input data format selection, and others. These functions are software controlled. PCM1716 can be operated in two different modes, software mode or hardware mode. Software mode is a three-wire interface using pin 28 (ML), 27 (MC), and 26 (MD).

PCM1716 can also be operated in hardware mode, where static control signals are used on pin 28 (115), pin 27 (DM1), pin 26 (DM0) and pin 23 (IWO).

This basic operation mode as software or hardware can be selected by pin 24 (MODE) as shown in Table II.

MODE (pin 24) = H	Software Mode
MODE (pin 24) = L	Hardware Mode

TABLE II. Mode Control.

Table III indicates which functions are selectable within the users chosen mode. All of the functions shown are selectable within the software mode, but only de-emphasis control, soft mute and input data format may be selected when using PCM1716 in the hardware mode.

FUNCTION	SOFTWARE (Mode = H)	HARDWARE (Mode = L)
Input Data Format Selection	O	O
Input Data Bit Selection	O	O
Input LRCIN Polarity Selection	O	X
De-emphasis Control	O	O
Mute	O	O
Attenuation	O	X
Infinity Zero Mute Control	O	X
DAC Operation Control	O	X
Slow Roll-Off Selection	O	X
Output Phase Selection	O	X
CLKO Output Selection	O	X

NOTE: O = Selectable, X: Not Selectable.

TABLE III. Mode Control, Selectable Functions.

### HARDWARE MODE (MODE = L)

In hardware mode, the following function can be selected.

#### De-emphasis control

De-emphasis control can be selected by DM1 (pin 27) and DM0 (pin 26)

DM1 (Pin 27)	DM0 (Pin 26)	DE-EMPHASIS
L	L	OFF
L	H	48kHz
H	L	44.1kHz
H	H	32kHz

TABLE IV. De-emphasis Control.

### Input Audio Data Format

Input data format can be selected by I<sup>2</sup>S (pin 28) and IWO (pin 23)

I <sup>2</sup> S (Pin 28)	IWO (Pin 23)	DATA FORMAT
L	L	16-Bit Data Word, Normal, Right Justified
L	H	20-Bit Data Word, Normal, Right Justified
H	L	16-Bit Data Word, I <sup>2</sup> S Format
H	H	24-Bit Data Word, I <sup>2</sup> S Format

TABLE V. Data Format Control.

### SOFT MUTE

Soft Mute function can be controlled by  $\overline{\text{MUTE}}$  (pin 25)

$\overline{\text{MUTE}}$ (Pin 25)	SOFT MUTE
L	Mute ON
H	Mute OFF (Normal Operation)

### SOFTWARE MODE (MODE = H)

PCM1716's special functions at software mode is shown in Table VI. These functions are controlled using a ML, MC, MD serial control signal.

### MAPPING OF PROGRAM REGISTERS

	B15	B14	B13	B12	B11	B10	B9	B8	B7	B6	B5	B4	B3	B2	B1	B0
MODE0	res	res	res	res	res	A1	A0	LDL	AL7	AL6	AL5	AL4	AL3	AL2	AL1	AL0
MODE1	res	res	res	res	res	A1	A0	LDR	AR7	AR6	AR5	AR4	AR3	AR2	AR1	AR0
MODE2	res	res	res	res	res	A1	A0	res	res	res	res	IW1	IW0	OPE	DEM	MUT
MODE3	res	res	res	res	res	A1	A0	IZD	SF1	SF0	CK0	REV	SR0	ATC	LRP	I <sup>2</sup> S

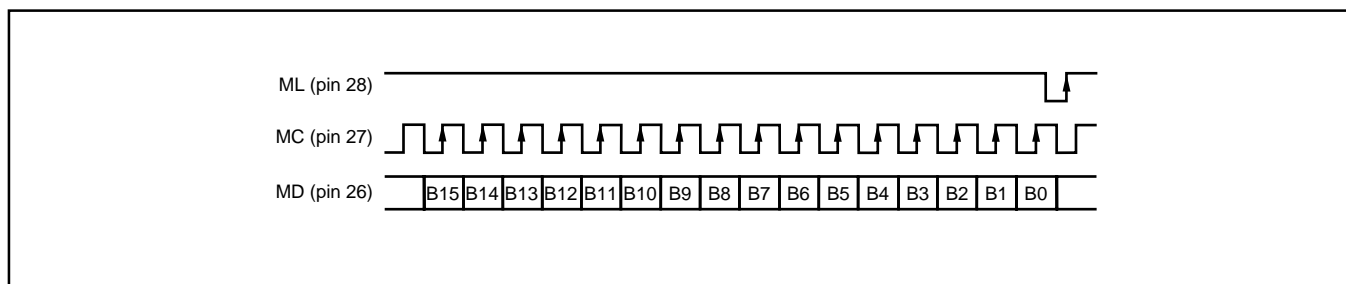

FIGURE 7. Three-Wire Serial Interface.

FUNCTION	DEFAULT MODE
Input Audio Data Format Selection Standard Format Left Justified I <sup>2</sup> S Format	Standard Format
Input Audio Data Bit Selection 16-Bit 20-Bit 24-Bit	16-Bit
Input LRCIN Polarity Selection Lch/Rch = High/Low Lch/Rch = Low/High	Lch/Rch = High/Low
De-emphasis Control	OFF
Soft Mute Control	OFF
Attenuation Control Lch, Rch Individually Lch, Rch Common	0dB, Individual
Infinite Zero Mute Control	Not Operated
DAC Operation Control	Operated
Sampling Rate Selection for De-emphasis Standard Frequency 44.1kHz 48kHz 32kHz	44.1kHz
Slow Roll-Off Selection	Not Selected (Sharp Roll-Off)
Output Phase Selection	Not Inverted
CLK0 Output Selection	Input Frequency

TABLE VI. Selectable Functions and Default.

### PROGRAM REGISTER BIT MAPPING

PCM1716's special functions are controlled using four program registers which are 16 bits long. These registers are all loaded using MD. After the 16 data bits are clocked in, ML is used to latch in the data to the appropriate register. Table VII shows the complete mapping of the four registers and Figure 7 illustrates the serial interface timing.

REGISTER NAME	BIT NAME	DESCRIPTION
Register 0	AL (7:0)	DAC Attenuation Data for Lch
	LDL	Attenuation Data Load Control for Lch
	A (1:0) res	Register Address Reserved, should be "L"
Register 1	AR (7:0)	DAC Attenuation Data for Rch
	LDR	Attenuation Data Load Control for Rch
	A (1:0) res	Register Address Reserved, should be "L"
Register 2	MUT	Left and Right DACs Soft Mute Control
	DEM	De-emphasis Control
	OPE	Left and Right DACs Operation Control
	IW (1:0)	Input Audio Data Bit and Format Select
	res	Reserved
	A (1:0) res	Register Address Reserved, should be "L"
Register 3	I <sup>2</sup> S	Audio Data Format Select
	LRP	Polarity of LRCIN Select
	ATC	Attenuator Control
	SRO	Slow Roll-Off Select
	REV	Output Phase Select
	CKO	CLKO Output Select
	SF (1:0)	Sampling Rate Select
	IZD	Internal Zero Detection Circuit Control
	A (1:0)	Register Address
	res	Reserved, should be "L"

TABLE VII. Register Functions

### REGISTER 0 (A1 = 0, A0 = 0)

B15	B14	B13	B12	B11	B10	B9	B8	B7	B6	B5	B4	B3	B2	B1	B0
res	res	res	res	res	A1	A0	LDL	AL7	AL6	AL5	AL4	AL3	AL2	AL1	AL0

Register 0 is used to control left channel attenuation. Bits 0 - 7 (AL0 - AL7) are used to determine the attenuation level. The level of attenuation is given by:

$$ATT = 0.5 \times (\text{data} - 255) \text{ (dB)}$$

$$FFh = -0\text{dB}$$

$$FEh = -0.5\text{dB}$$

$$\vdots$$

$$01h = -127.5\text{dB}$$

$$00h = -\infty (= \text{Mute})$$

### ATTENUATION DATA LOAD CONTROL

Bit 8 (LDL) is used to control the loading of attenuation data in B0:B7. When LDL is set to 0, attenuation data will be loaded into AL0:AL7, but it will not affect the attenuation level until LDL is set to 1. LDR in Register 1 has the same function for right channel attenuation.

### REGISTER 1 (A1 = 0, A0 = 1)

B15	B14	B13	B12	B11	B10	B9	B8	B7	B6	B5	B4	B3	B2	B1	B0
res	res	res	res	res	A1	A0	LDR	AR7	AR6	AR5	AR4	AR3	AR2	AR1	AR0

Register 1 is used to control right channel attenuation. As in Register 1, bits 0 - 7 (AR0 - AR7) control the level of attenuation.

### REGISTER 2 (A1 = 1, A0 = 0)

B15	B14	B13	B12	B11	B10	B9	B8	B7	B6	B5	B4	B3	B2	B1	B0
res	res	res	res	res	A1	A0	res	res	res	res	IW1	IW0	OPE	DEM	MUTE

Register 2 is used to control soft mute, de-emphasis, operation enable, input resolution, and input audio data bit and format.

MUT (B0)	
MUT = L	Soft Mute OFF
MUT = H	Soft Mute ON

DEM (B1)	
DEM = L	De-emphasis OFF
DEM = H	De-emphasis ON

OPE (B2)	
OPE = L	Normal Operation
OPE = H	DAC Operation OFF

when OPE (B2) is "HIGH", the output of the DAC will be forced to bipolar zero, irrespective of any input data.

IWO (B3), IW1 (B4) and I<sup>2</sup>S (B0) of Register 3

These registers, IWO, IW1, I<sup>2</sup>S determine the input data word and input data format as shown below.

IW1	IW0	I <sup>2</sup> S	Audio Interface
0	0	0	16-Bit Standard (Right-Justified)
0	1	0	20-Bit Standard (Right-Justified)
1	0	0	24-Bit Standard (Right-Justified)
1	1	0	24-Bit Left-Justified (MSB First)
0	0	1	16-Bit I <sup>2</sup> S
0	1	1	24-Bit I <sup>2</sup> S
1	0	1	Reserved
1	1	1	Reserved

### REGISTER 3 (A1 = 1, A0 = 1)

B15	B14	B13	B12	B11	B10	B9	B8	B7	B6	B5	B4	B3	B2	B1	B0
res	res	res	res	res	A1	A0	IZD	SF1	SF0	CKO	REV	SRO	ATC	LRP	I <sup>2</sup> S

### REGISTER 3 (A1 = 1, A0 = 1)

Register 3 is used to control input data format and polarity, attenuation channel control, system clock frequency, sampling frequency, infinite zero detection, output phase, CLKO output, and slow roll-off.

Bit 8 is used to control the infinite zero detection function (IZD).

When IZD is "LOW", the zero detect circuit is off. Under this condition, no automatic muting will occur if the input is continuously zero. When IZD is "HIGH", the zero detect feature is enabled. If the input data is continuously zero for 65, 536 cycles of BCKIN, the output will be immediately

forced to a bipolar zero state ( $V_{CC}/2$ ). The zero detection feature is used to avoid noise which may occur when the input is DC. When the output is forced to bipolar zero, there may be an audible click. PCM1716 allows the zero detect feature to be disabled so the user can implement an external muting circuit.

<b>IZD (B8)</b>	
B8 = L	Zero Detect Mute OFF
B8 = H	Zero Detect Mute ON

Bits 6 (SF0) and 7 (SF1) are used to select the sampling frequency for De-emphasis.

<b>SF1</b>	<b>SF0</b>	<b>Sampling Rate</b>
0	0	Reserved
0	1	48kHz
1	0	44.1kHz
1	1	32kHz

CKO (B5) is output frequency control at CLKO pin, can be selected as Buffer (1/1) or half rate of input frequency (1/2).

CKO = L	Buffer Out of XT <sub>i</sub> Clock
CKO = H	Half (1/2) Frequency Out of XT <sub>i</sub> Clock

REF (B4) is output analog signal phase control.

REV = L	Normal Output
REV = H	Inverted Output

SRO (B3) is roll-off performance of digital filter selection.

SRO = L	Sharp Roll-Off
SRO = H	Slow Roll-Off

ATC (B2) is used as an attenuation control. When bit 3 is set HIGH, the attenuation data on Register 0 is used for both channels, and the data in Register 1 is ignored. When bit 3 is LOW, each channel has separate attenuation data.

ATC = L	Ch Individual ATT Control
ATC = H	Common ATT Control

Bits 0 (I<sup>2</sup>S) and 1 (LRP) are used to control the input data format. A “LOW” on bit 0 sets the format to (MSB-first, right-justified Japanese format) and a “HIGH” sets the format to I<sup>2</sup>S (Philips serial data protocol). Bit 1 (LRP) is used to select the polarity of LRCIN (sample rate clock). When bit 1 is “LOW”, left channel data is assumed when LRCIN is in a “HIGH” phase and right channel data is assumed when LRCIN is in a “LOW” phase. When bit 1 is “HIGH”, the polarity assumption is reversed.

LRP = L	<table border="1"><tr><td>L</td><td>R</td></tr></table> H/Lch	L	R
L	R		
LRP = H	<table border="1"><tr><td>L</td><td>R</td></tr></table> L/Lch	L	R
L	R		

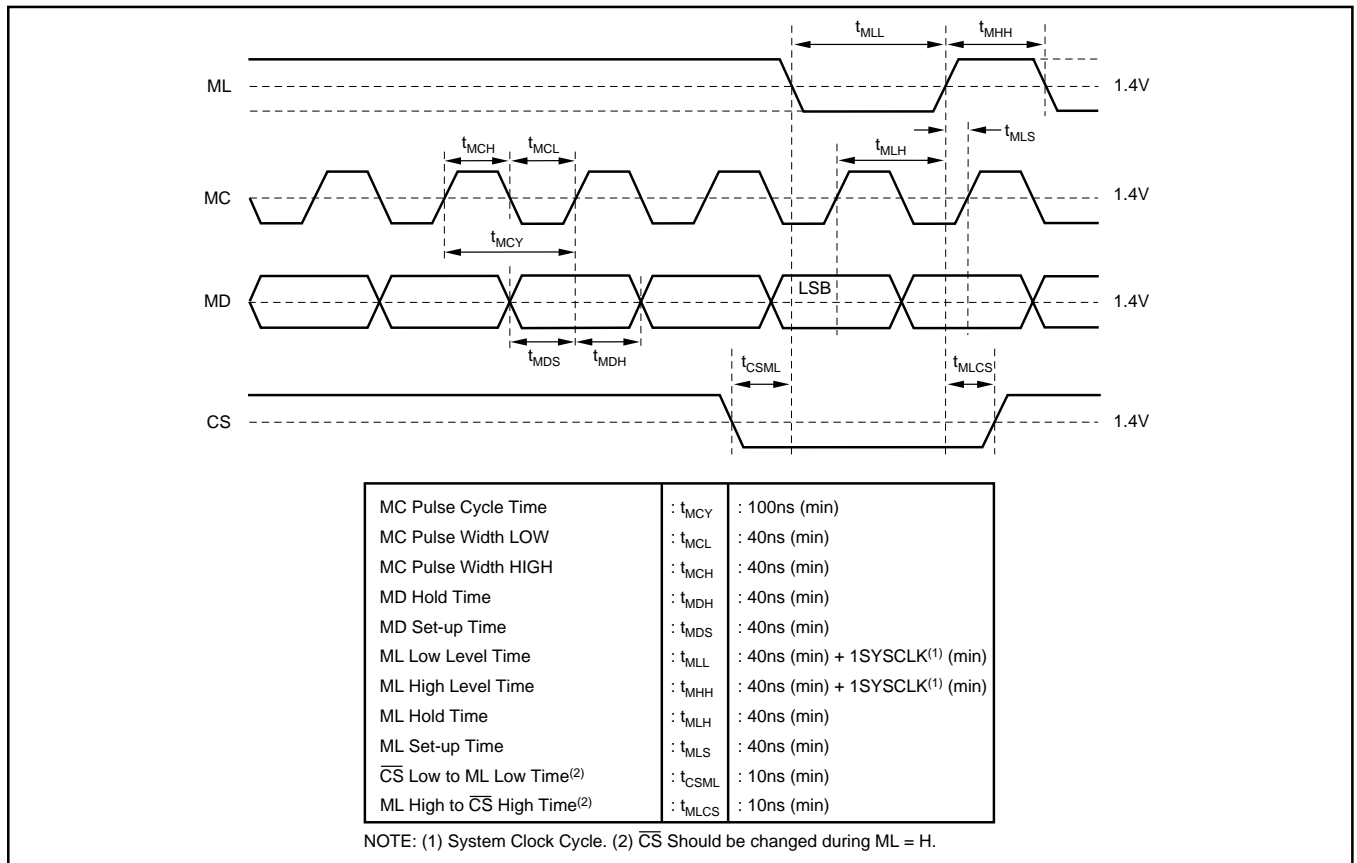

FIGURE 8. Program Register Input Timing.

# THEORY OF OPERATION

The delta-sigma section of PCM1716 is based on a 8-level amplitude quantizer and a 4th-order noise shaper. This section converts the oversampled input data to 8-level delta-sigma format.

This newly developed, “Enhanced Multi-level Delta-Sigma” architecture achieves high-grade audio dynamic performance and sound quality.

A block diagram of the 8-level delta-sigma modulator is shown in Figure 9. This 8-level delta-sigma modulator has

the advantage of stability and clock jitter sensitivity over the typical one-bit (2 level) delta-sigma modulator.

The combined oversampling rate of the delta-sigma modulator and the internal 8-times interpolation filter is  $64f_s$  for all system clock ratios ( $256/384/512/768f_s$ ).

The theoretical quantization noise performance of the 8-level delta-sigma modulator is shown in Figure 10. This enhanced multi-level delta-sigma architecture also has advantages for input clock jitter sensitivity due to the multi-level quantizer, simulated jitter sensitivity is shown in Figure 11.

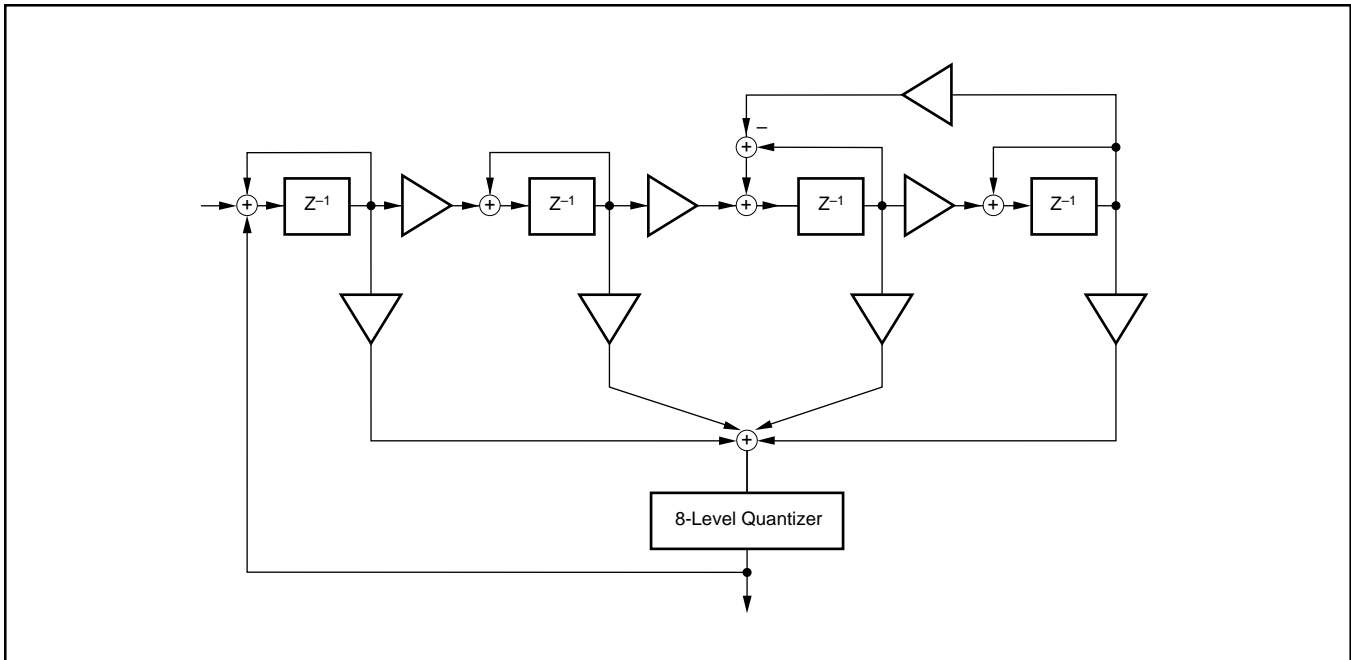

FIGURE 9. 8-Level Delta-Sigma Modulator.

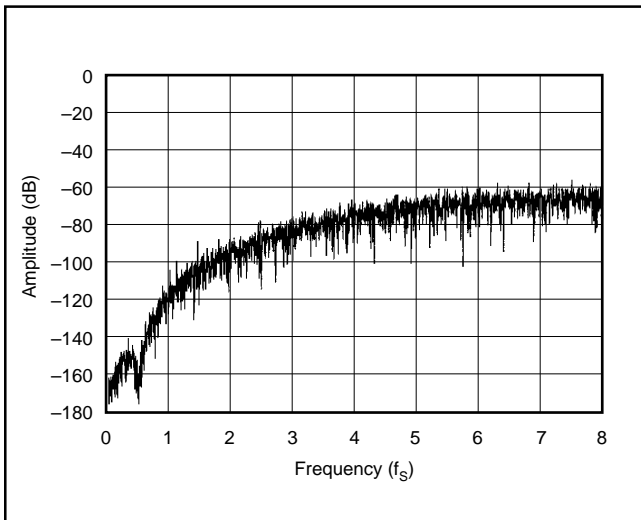

FIGURE 10. Quantization Noise Spectrum.

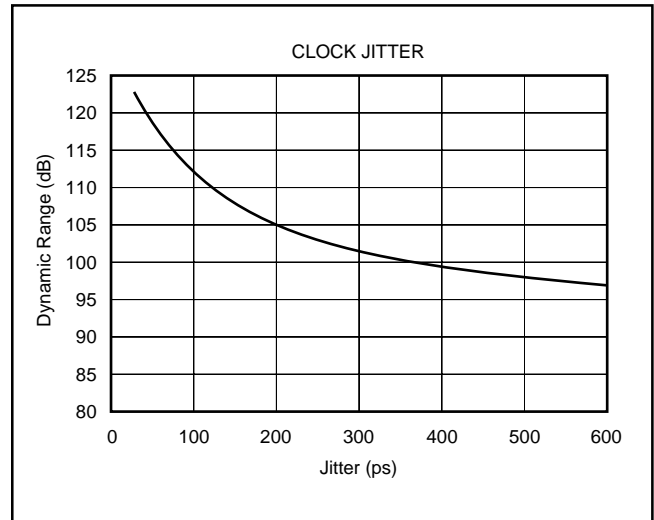

FIGURE 11. Jitter Sensitivity.

# APPLICATION CONSIDERATIONS

## DELAY TIME

There is a finite delay time in delta-sigma converters. In A/D converters, this is commonly referred to as latency. For a delta-sigma D/A converter, delay time is determined by the order number of the FIR filter stage, and the chosen sampling rate. The following equation expresses the delay time of PCM1716:

$$T_D = 30 \times 1/f_S$$

$$\text{For } f_S = 44.1\text{kHz}, T_D = 30/44.1\text{kHz} = 680\mu\text{s}$$

Applications using data from a disc or tape source, such as CD audio, DVD audio, Video CD, DAT, Minidisc, etc., generally are not affected by delay time. For some professional applications such as broadcast audio for studios, it is important for total delay time to be less than 2ms.

## OUTPUT FILTERING

For testing purposes all dynamic tests are done on the PCM1716 using a 20kHz low pass filter. This filter limits the measured bandwidth for THD+N, etc. to 20kHz. Failure to use such a filter will result in higher THD+N and lower SNR and Dynamic Range readings than are found in the specifications. The low pass filter removes out of band noise. Although it is not audible, it may affect dynamic specification numbers.

The performance of the internal low pass filter from DC to 40kHz is shown in Figure 12. The higher frequency roll-off of the filter is shown in Figure 13. If the user's application has the PCM1716 driving a wideband amplifier, it is recommended to use an external low pass filter.

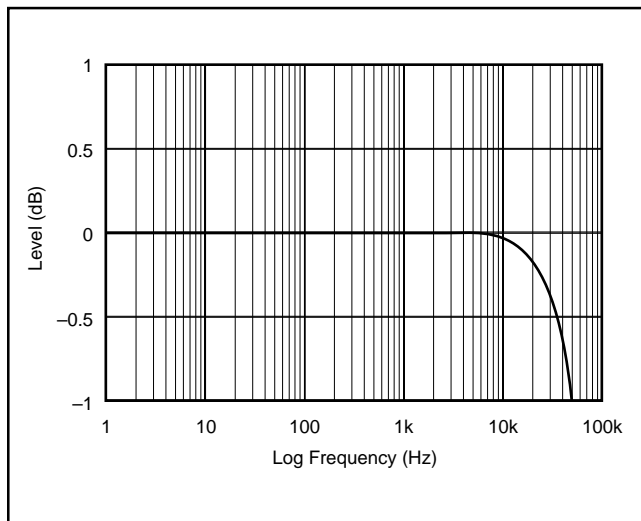

FIGURE 12. Low Pass Filter Response.

## BYPASSING POWER SUPPLIES

The power supplies should be bypassed as close as possible to the unit. Refer to Figure 15 for optimal values of bypass capacitors.

## POWER SUPPLY CONNECTIONS

PCM1716 has three power supply connections: digital ( $V_{DD}$ ), and analog ( $V_{CC}$ ). Each connection also has a separate ground. If the power supplies turn on at different times, there is a possibility of a latch-up condition. To avoid this condition, it is recommended to have a common connection between the digital and analog power supplies. If separate supplies are used without a common connection, the delta between the two supplies during ramp-up time must be less than 0.1V.

An application circuit to avoid a latch-up condition is shown in Figure 14.

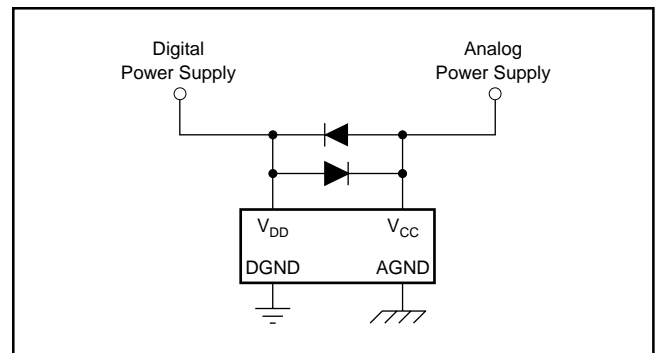

FIGURE 14. Latch-Up Prevention Circuit.

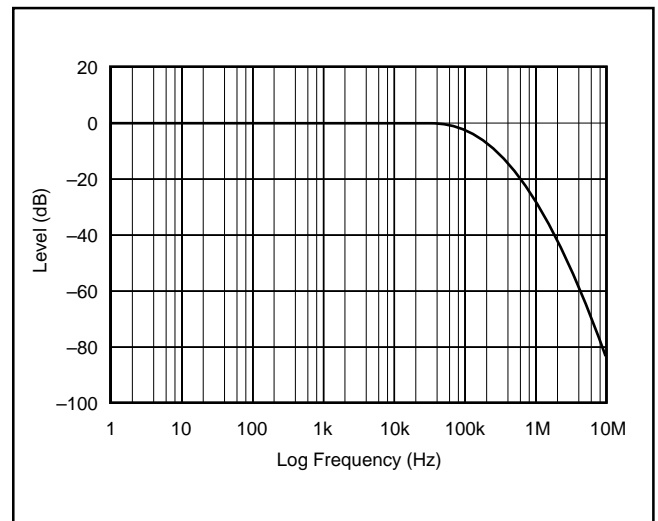

FIGURE 13. Low Pass Filter Response.

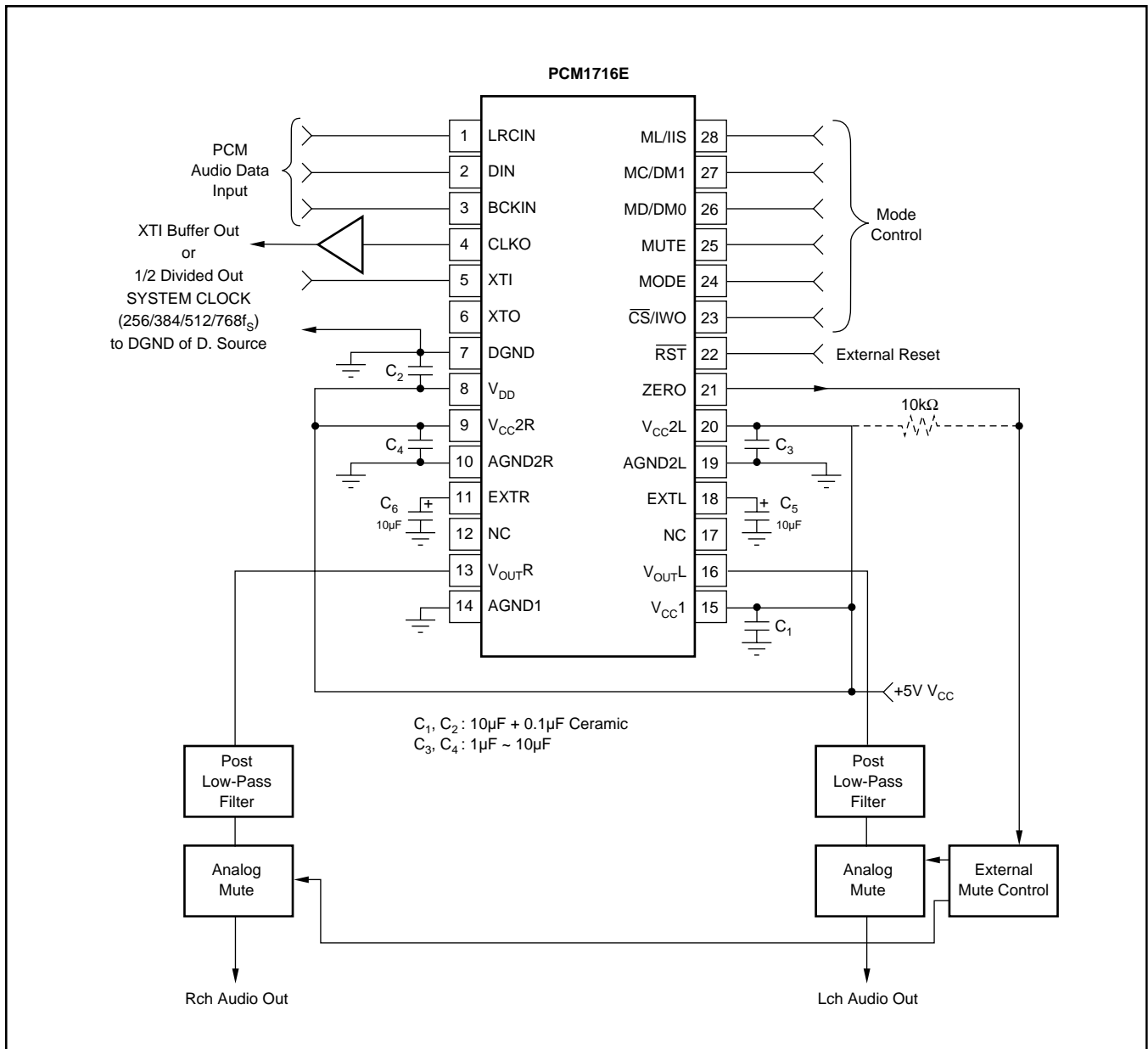

FIGURE 15. Typical Circuit Connection Diagram.

---

## PACKAGING INFORMATION

ORDERABLE DEVICE	STATUS(1)	PACKAGE TYPE	PACKAGE DRAWING	PINS	PACKAGE QTY
PCM1716E	ACTIVE	SSOP	DB	28	47
PCM1716E/2K	ACTIVE	SSOP	DB	28	2000

(1) The marketing status values are defined as follows:

**ACTIVE:** Product device recommended for new designs.

**LIFEBUY:** TI has announced that the device will be discontinued, and a lifetime-buy period is in effect.

**NRND:** Not recommended for new designs. Device is in production to support existing customers, but TI does not recommend using this part in a new design.

**PREVIEW:** Device has been announced but is not in production. Samples may or may not be available.

**OBSOLETE:** TI has discontinued the production of the device.

---

## IMPORTANT NOTICE

Texas Instruments Incorporated and its subsidiaries (TI) reserve the right to make corrections, modifications, enhancements, improvements, and other changes to its products and services at any time and to discontinue any product or service without notice. Customers should obtain the latest relevant information before placing orders and should verify that such information is current and complete. All products are sold subject to TI's terms and conditions of sale supplied at the time of order acknowledgment.

TI warrants performance of its hardware products to the specifications applicable at the time of sale in accordance with TI's standard warranty. Testing and other quality control techniques are used to the extent TI deems necessary to support this warranty. Except where mandated by government requirements, testing of all parameters of each product is not necessarily performed.

TI assumes no liability for applications assistance or customer product design. Customers are responsible for their products and applications using TI components. To minimize the risks associated with customer products and applications, customers should provide adequate design and operating safeguards.

TI does not warrant or represent that any license, either express or implied, is granted under any TI patent right, copyright, mask work right, or other TI intellectual property right relating to any combination, machine, or process in which TI products or services are used. Information published by TI regarding third-party products or services does not constitute a license from TI to use such products or services or a warranty or endorsement thereof. Use of such information may require a license from a third party under the patents or other intellectual property of the third party, or a license from TI under the patents or other intellectual property of TI.

Reproduction of information in TI data books or data sheets is permissible only if reproduction is without alteration and is accompanied by all associated warranties, conditions, limitations, and notices. Reproduction of this information with alteration is an unfair and deceptive business practice. TI is not responsible or liable for such altered documentation.

Resale of TI products or services with statements different from or beyond the parameters stated by TI for that product or service voids all express and any implied warranties for the associated TI product or service and is an unfair and deceptive business practice. TI is not responsible or liable for any such statements.

Following are URLs where you can obtain information on other Texas Instruments products and application solutions:

<b>Products</b>		<b>Applications</b>	
Amplifiers	<a href="http://amplifier.ti.com">amplifier.ti.com</a>	Audio	<a href="http://www.ti.com/audio">www.ti.com/audio</a>
Data Converters	<a href="http://dataconverter.ti.com">dataconverter.ti.com</a>	Automotive	<a href="http://www.ti.com/automotive">www.ti.com/automotive</a>
DSP	<a href="http://dsp.ti.com">dsp.ti.com</a>	Broadband	<a href="http://www.ti.com/broadband">www.ti.com/broadband</a>
Interface	<a href="http://interface.ti.com">interface.ti.com</a>	Digital Control	<a href="http://www.ti.com/digitalcontrol">www.ti.com/digitalcontrol</a>
Logic	<a href="http://logic.ti.com">logic.ti.com</a>	Military	<a href="http://www.ti.com/military">www.ti.com/military</a>
Power Mgmt	<a href="http://power.ti.com">power.ti.com</a>	Optical Networking	<a href="http://www.ti.com/opticalnetwork">www.ti.com/opticalnetwork</a>
Microcontrollers	<a href="http://microcontroller.ti.com">microcontroller.ti.com</a>	Security	<a href="http://www.ti.com/security">www.ti.com/security</a>
		Telephony	<a href="http://www.ti.com/telephony">www.ti.com/telephony</a>
		Video & Imaging	<a href="http://www.ti.com/video">www.ti.com/video</a>
		Wireless	<a href="http://www.ti.com/wireless">www.ti.com/wireless</a>

Mailing Address: Texas Instruments  
Post Office Box 655303 Dallas, Texas 75265

Copyright © 2003, Texas Instruments Incorporated

## Looking for pricing, stock, or lifecycle information?

Click below to explore more details on WIN SOURCE:

 [View PCM1716E/2K on WIN SOURCE](#)

 [Texas Instruments](#) Information

## Optimize Your Supply Chain with WIN SOURCE Solutions

-  Global Sourcing Solution
-  Obsolete Management
-  Cost Control Management
-  Shortage Management
-  Alternative Solution
-  Excess Inventory Management