



**THE DATASHEET OF
PCM1728E/2K**





PCM1728

SoundPlus™ 24-Bit, 96kHz Sampling CMOS Delta-Sigma Stereo Audio DIGITAL-TO-ANALOG CONVERTER

FEATURES

- ENHANCED MULTI-LEVEL DELTA-SIGMA DAC
- SAMPLING FREQUENCY (f_s): 16kHz - 96kHz
- INPUT AUDIO DATA WORD:
16-, 20-, 24-Bit
- HIGH PERFORMANCE:
THD+N: -96dB
Dynamic Range: 106dB
SNR: 106dB
Analog Output Range: $0.62 \times V_{CC}$ (Vp-p)
- 8x OVERSAMPLING DIGITAL FILTER:
Stop Band Attenuation: -82dB
Passband Ripple: ± 0.002 dB
- MULTI FUNCTIONS:
Digital De-emphasis
Soft Mute
Zero Flag
- +5V SINGLE SUPPLY OPERATION
- SMALL 28-LEAD SSOP PACKAGE

DESCRIPTION

The PCM1728 is designed for mid- to high-grade digital audio applications which achieve 96kHz sampling rates with 24-bit audio data. PCM1728 uses a newly developed, enhanced multi-level delta-sigma modulator architecture that improves audio dynamic performance and reduces jitter sensitivity in actual applications. The internal digital filter operates at 8X oversampling at a 96kHz sampling rate.

The PCM1728 has superior audio dynamic performance, 24-bit resolution, and 96kHz sampling, making it ideal for mid- to high-grade audio applications such as CD, DVD, and musical instruments.

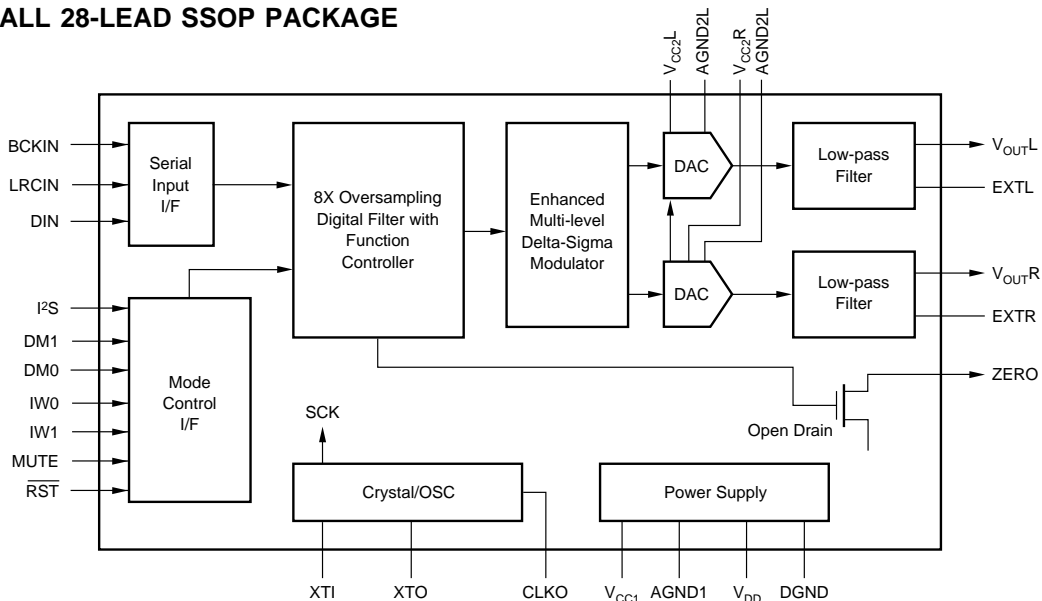

International Airport Industrial Park • Mailing Address: PO Box 11400, Tucson, AZ 85734 • Street Address: 6730 S. Tucson Blvd., Tucson, AZ 85706 • Tel: (520) 746-1111 • Twx: 910-952-1111
Internet: <http://www.burr-brown.com/> • FAXLine: (800) 548-6133 (US/Canada Only) • Cable: BBRCORP • Telex: 066-6491 • FAX: (520) 889-1510 • Immediate Product Info: (800) 548-6132

SPECIFICATIONS

All specifications at +25°C, +V_{CC} = +V_{DD} = +5V, f_S = 44.1kHz, and 24-bit input data, SYSCLK = 384f_S, unless otherwise noted.

PARAMETER	CONDITIONS	PCM1728			UNITS
		MIN	TYP	MAX	
RESOLUTION		24			Bits
DATA FORMAT Audio Data Interface Format Data Bit Length Audio Data Format Sampling Frequency (f _S) System Clock Frequency ⁽¹⁾		Standard/I ² S 16/20/24 Selectable MSB-First, Two's Binary Comp 16 96 256/384/512/768f _S			kHz
DIGITAL INPUT/OUTPUT LOGIC LEVEL Input Logic Level V _{IH} V _{IL} Output Logic Level (CLKO) V _{OH} V _{OL}	I _{OH} = 2mA I _{OL} = 4mA	2.0 4.5		0.8 0.5	V V V V
CLKO PERFORMANCE⁽²⁾ Output Rise Time Output Fall Time Output Duty Cycle	20 ~ 80% V _{DD} , 10pF 80 ~ 20% V _{DD} , 10pF 10pF Load		5.5 4 37		ns ns %
DYNAMIC PERFORMANCE⁽³⁾ (24-Bit Data) THD+N V _O = 0dB V _O = -60dB Dynamic Range Signal-to-Noise Ratio Channel Separation	f _S = 44.1kHz f _S = 96kHz f _S = 44.1kHz f _S = 44.1kHz EIAJ A-weighted f _S = 96kHz A-weighted f _S = 44.1kHz EIAJ A-weighted f _S = 96kHz A-weighted f _S = 44.1kHz f _S = 96kHz		-97 -94 -42 98 106 103 98 106 103 96 102 101	-90	dB dB dB dB dB dB dB dB dB dB
DYNAMIC PERFORMANCE⁽³⁾ (16-Bit Data) THD+N V _O = 0dB Dynamic Range	f _S = 44.1kHz f _S = 96kHz f _S = 44.1kHz EIAJ A-weighted f _S = 96kHz A-weighted		-94 -92 98 97		dB dB dB dB
DC ACCURACY Gain Error Gain Mismatch: Channel-to-Channel Bipolar Zero Error	V _O = 0.5V _{CC} at Bipolar Zero		±1.0 ±1.0 ±30	±3.0 ±3.0 ±60	% of FSR % of FSR mV
ANALOG OUTPUT Output Voltage Center Voltage Load Impedance	Full Scale (0dB) AC Load		0.62 V _{CC} 0.5 V _{CC} 5		V _{p-p} V kΩ
DIGITAL FILTER PERFORMANCE Filter Characteristics Passband Stopband Passband Ripple Stopband Attenuation Delay Time De-emphasis Error	±0.002dB -3dB 0.546f _S Stop Band = 0.546f _S Stop Band = 0.567f _S 30/f _S			0.454f _S 0.490f _S ±0.002 ±0.1	dB dB dB sec dB
INTERNAL ANALOG FILTER -3dB Bandwidth Passband Response	f = 20kHz		100 -0.16		kHz dB
POWER SUPPLY REQUIREMENTS Voltage Range Supply Current: I _{CC} + I _{DD} Power Dissipation	V _{DD} , V _{CC} f _S = 44.1kHz f _S = 96kHz f _S = 44.1kHz f _S = 96kHz	4.5	5 32 45 160 225	5.5 45 225	VDC mA mA mW mW
TEMPERATURE RANGE Operation Storage		-25 -55		+85 +100	°C °C

NOTES: (1) Refer section of system clock. (2) External buffer is recommended. (3) Dynamic performance specs are tested with 20kHz low pass filter and THD+N specs are tested with 30kHz LPF, 400Hz HPF, Average Mode.

PIN CONFIGURATION

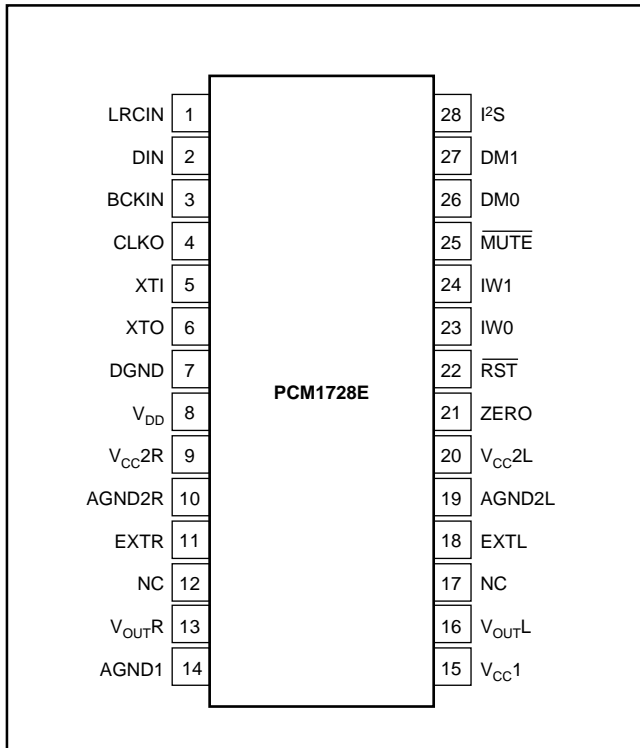

PACKAGE INFORMATION

PRODUCT	PACKAGE	PACKAGE DRAWING NUMBER ⁽¹⁾
PCM1728E	28-Pin SSOP	324

NOTE: (1) For detailed drawing and dimension table, please see end of data sheet, or Appendix C of Burr-Brown IC Data Book.

ABSOLUTE MAXIMUM RATINGS

Power Supply Voltage	+6.5V
+V _{CC} to +V _{DD} Difference	±0.1V
Input Logic Voltage	-0.3V to (V _{DD} + 0.3V)
Input Current (except power supply)	±10mA
Power Dissipation	400mW
Operating Temperature Range	-25°C to +85°C
Storage Temperature	-55°C to +125°C
Lead Temperature (soldering, 5s)	+260°C

PIN ASSIGNMENTS

PIN	NAME	I/O	DESCRIPTION
1	LRCIN	IN	Left and Right Clock Input. This clock is equal to the sampling rate - f_s . ⁽¹⁾
2	DIN	IN	Serial Audio Data Input ⁽¹⁾
3	BCKIN	IN	Bit Clock Input for Serial Audio Data. ⁽¹⁾
4	CLKO	OUT	Buffered Output of Oscillator. Equivalent to System Clock.
5	XTI	IN	Oscillator Input (External Clock Input)
6	XTO	OUT	Oscillator Output
7	DGND	—	Digital Ground
8	V _{DD}	—	Digital Power +5V
9	V _{CC2R}	—	Analog Power +5V
10	AGND2R	—	Analog Ground
11	EXTR	OUT	Rch, Common Pin of Analog Output Amp
12	NC	—	No Connection
13	V _{OUTR}	OUT	Rch, Analog Voltage Output of Audio Signal
14	AGND1	—	Analog Ground
15	V _{CC1}	—	Analog Power +5V
16	V _{OUTL}	OUT	Lch, Analog Voltage Output of Audio Signal
17	NC	—	No Connection
18	EXTL	OUT	Lch, Common Pin of Analog Output Amp
19	AGND2L	—	Analog Ground
20	V _{CC2L}	—	Analog Power +5V
21	ZERO	OUT	Zero Data Flag
22	RST	IN	Reset. When this pin is LOW, the DF and modulators are held in reset. ⁽²⁾
23	IW0	IN	Input Format Selection ⁽³⁾
24	IW1	IN	Input Format Selection ⁽³⁾
25	MUTE	IN	Mute Control
26	DM0	IN	De-emphasis Selection 1 ⁽²⁾
27	DM1	IN	De-emphasis Selection 2 ⁽²⁾
28	I ² S	IN	Input Format Selection ⁽²⁾

NOTES: (1) Pins 1, 2, 3; Schmitt Trigger input. (2) Pins 22, 25, 26, 27, 28; Schmitt Trigger input with pull-up resistor. (3) Pins 23, 24; Schmitt Trigger input with pull-down resistor.



ELECTROSTATIC DISCHARGE SENSITIVITY

This integrated circuit can be damaged by ESD. Burr-Brown recommends that all integrated circuits be handled with appropriate precautions. Failure to observe proper handling and installation procedures can cause damage.

ESD damage can range from subtle performance degradation to complete device failure. Precision integrated circuits may be more susceptible to damage because very small parametric changes could cause the device not to meet its published specifications.

The information provided herein is believed to be reliable; however, BURR-BROWN assumes no responsibility for inaccuracies or omissions. BURR-BROWN assumes no responsibility for the use of this information, and all use of such information shall be entirely at the user's own risk. Prices and specifications are subject to change without notice. No patent rights or licenses to any of the circuits described herein are implied or granted to any third party. BURR-BROWN does not authorize or warrant any BURR-BROWN product for use in life support devices and/or systems.

TYPICAL PERFORMANCE CURVES

All specifications at +25°C, +V_{CC} = +V_{DD} = +5V, f_S = 44.1kHz, and 24-bit input data, SYSCLK = 384f_S, unless otherwise noted.

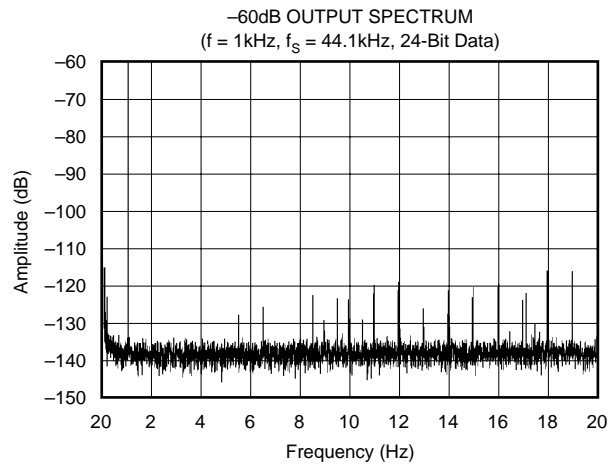
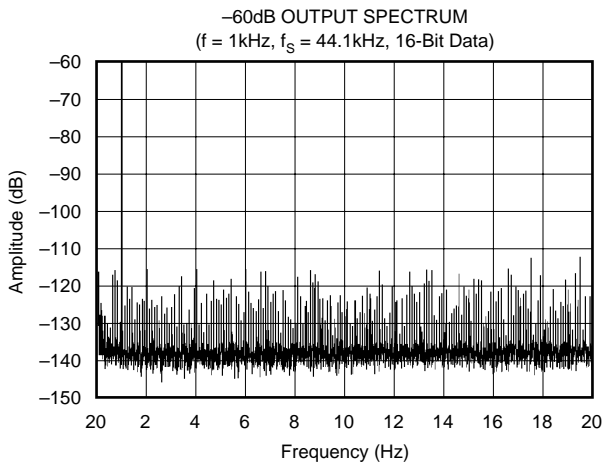
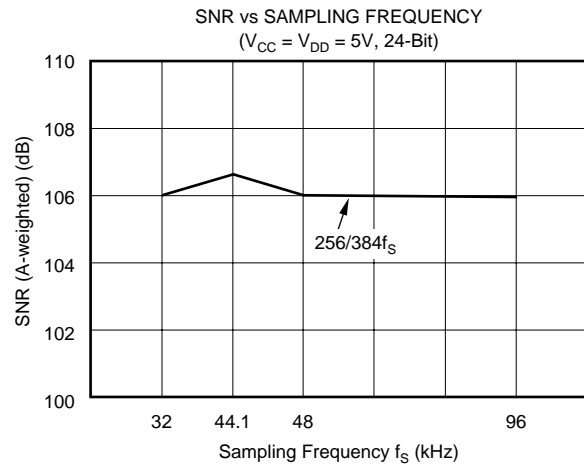
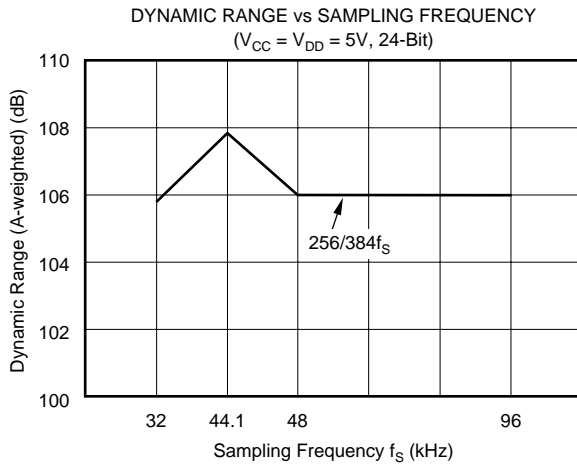
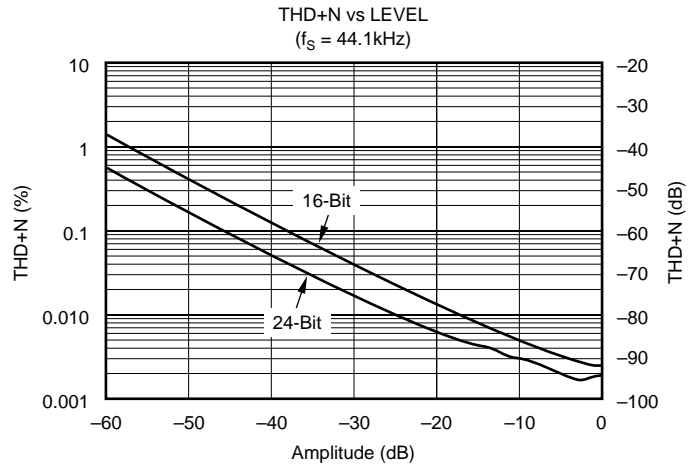
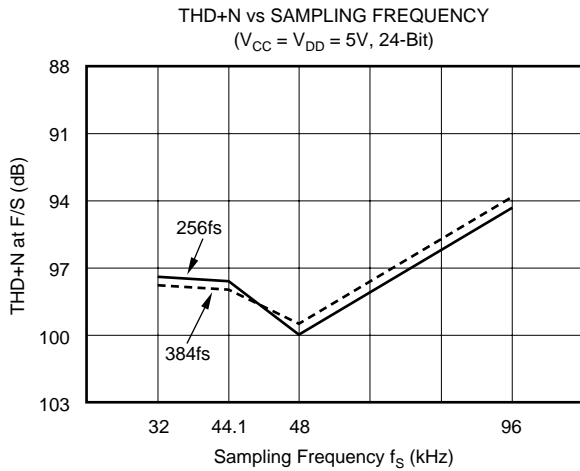

TYPICAL PERFORMANCE CURVES (CONT)

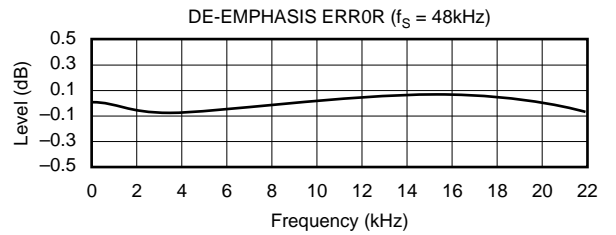
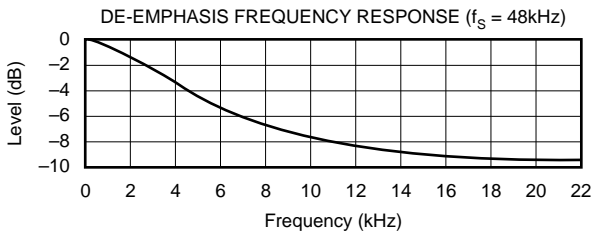
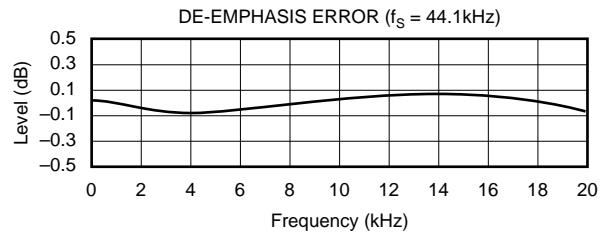
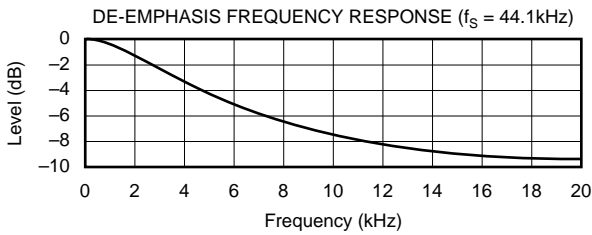
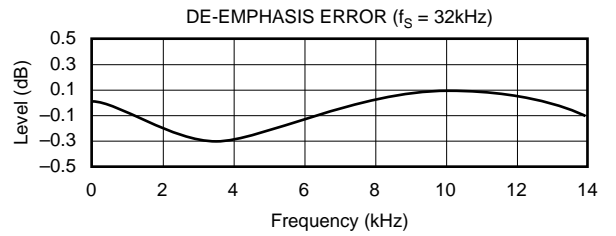
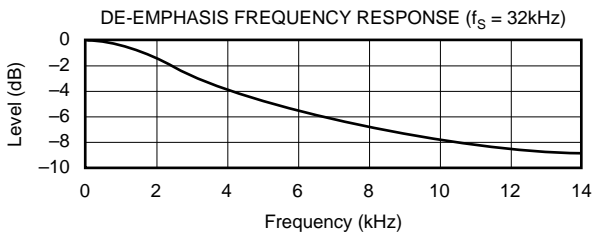
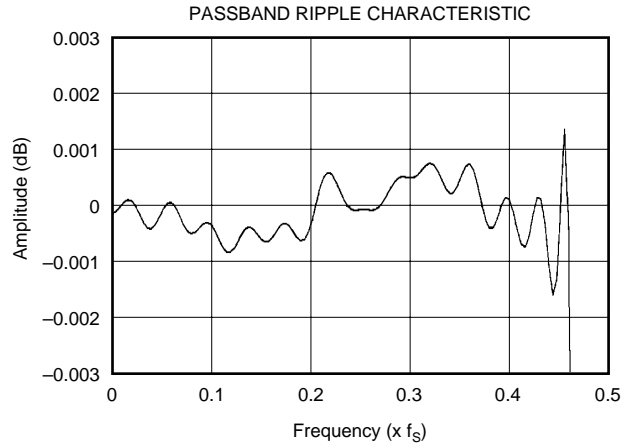
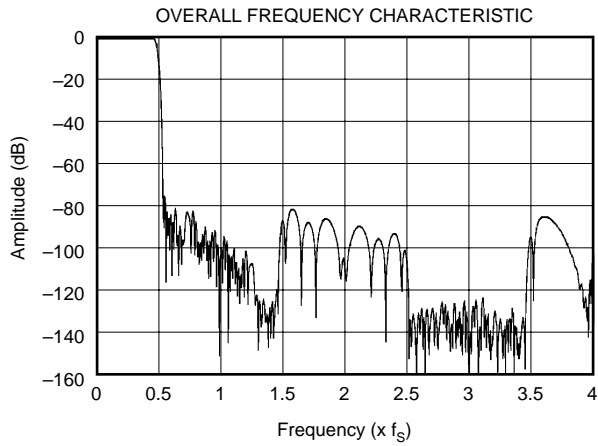

SYSTEM CLOCK

The system clock for PCM1728 must be either $256f_s$, $384f_s$, $512f_s$ or $768f_s$, where f_s is the audio sampling frequency (typically 32kHz, 44.1kHz, 48kHz, or 96kHz). But $768f_s$ at 96kHz is not accepted.

The system clock can be either a crystal oscillator placed between XTI (pin 5) and XTO (pin 6), or an external clock input to XTI. If an external system clock is used, XTO is open (floating). Figure 1 illustrates the typical system clock connections.

PCM1728 has a system clock detection circuit which automatically senses if the system clock is operating at $256f_s \sim 768f_s$. The system clock should be synchronized with LRCIN (pin 1) clock. LRCIN (left-right clock) operates at the sampling frequency f_s . In the event these clocks are not synchronized, PCM1728 can compensate for the phase difference internally. If the phase difference between left-right and system clocks is greater than 6-bit clocks (BCKIN), the synchronization is performed internally. While the synchronization is processing, the analog output is forced to a DC level at bipolar zero. The synchronization typically occurs in less than 1 cycle of LRCIN.

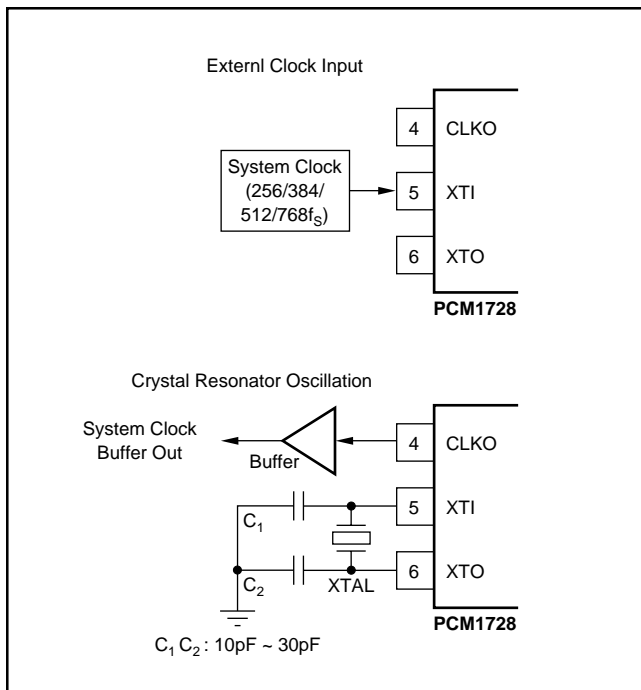

FIGURE 1. System Clock Connection.

Typical input system clock frequencies to the PCM1728 are shown in Table I, also, external input clock timing requirements are shown in Figure 2.

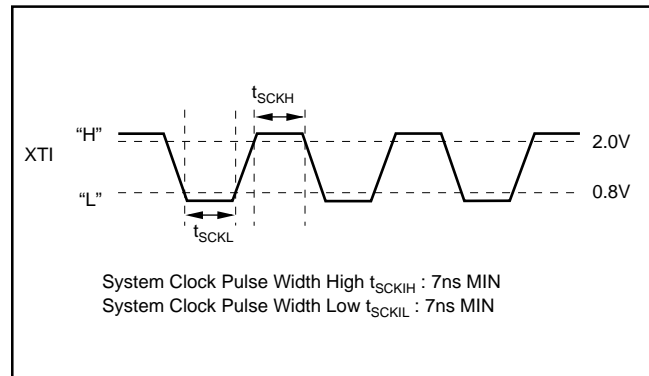

FIGURE 2. XTI Clock Timing.

DATA INTERFACE FORMATS

Digital audio data is interfaced to PCM1728 on pins 1, 2, and 3, LRCIN (left-right clock), DIN (data input) and BCKIN (bit clock). PCM1728 can accept both standard, I²S, and left justified data formats.

Figure 3 illustrates acceptable input data formats. Figure 4 shows required timing specification for digital audio data.

Reset

PCM1728 has both internal power-on reset circuit and the \overline{RST} pin (pin 22), which accepts an external forced reset by $\overline{RST} = \text{LOW}$. For internal power on reset, initialization is done automatically at power on $V_{DD} > 2.2V$ (typ). During internal reset = LOW, the output of the DAC is invalid and the analog outputs are forced to $V_{CC}/2$. Figure 5 illustrates the timing of the internal power on reset.

PCM1728 accepts an external forced reset when $\overline{RST} = \text{LOW}$. When $\overline{RST} = \text{LOW}$, the output of the DAC is invalid and the analog outputs are forced to $V_{CC}/2$ after internal initialization (1024 system clocks count after $\overline{RST} = \text{HIGH}$.) Figure 6 illustrates the timing of the \overline{RST} pin.

Zero Out (pin 21)

If the input data is continuously zero for 65536 cycles of BCK, an internal FET is switched to "ON". The drain of the internal FET is the zero-pin, it will enable "wired-or" with external circuit.

SAMPLING RATE FREQUENCY (f_s) - LRCIN	SYSTEM CLOCK FREQUENCY - MHz			
	256 f_s	384 f_s	512 f_s	768 f_s
32kHz	8.1920	12.2880	16.3840	24.5760
44.1kHz	11.2896	16.9340	22.5792	33.8688 ⁽¹⁾
48kHz	12.2880	18.4320	24.5760	36.8640 ⁽¹⁾
96kHz	24.5760	36.8640 ⁽¹⁾	49.1520 ⁽¹⁾	—

NOTE: (1) The internal crystal oscillator frequency cannot be larger than 24.576MHz.

TABLE I. Typical System Clock Frequency.

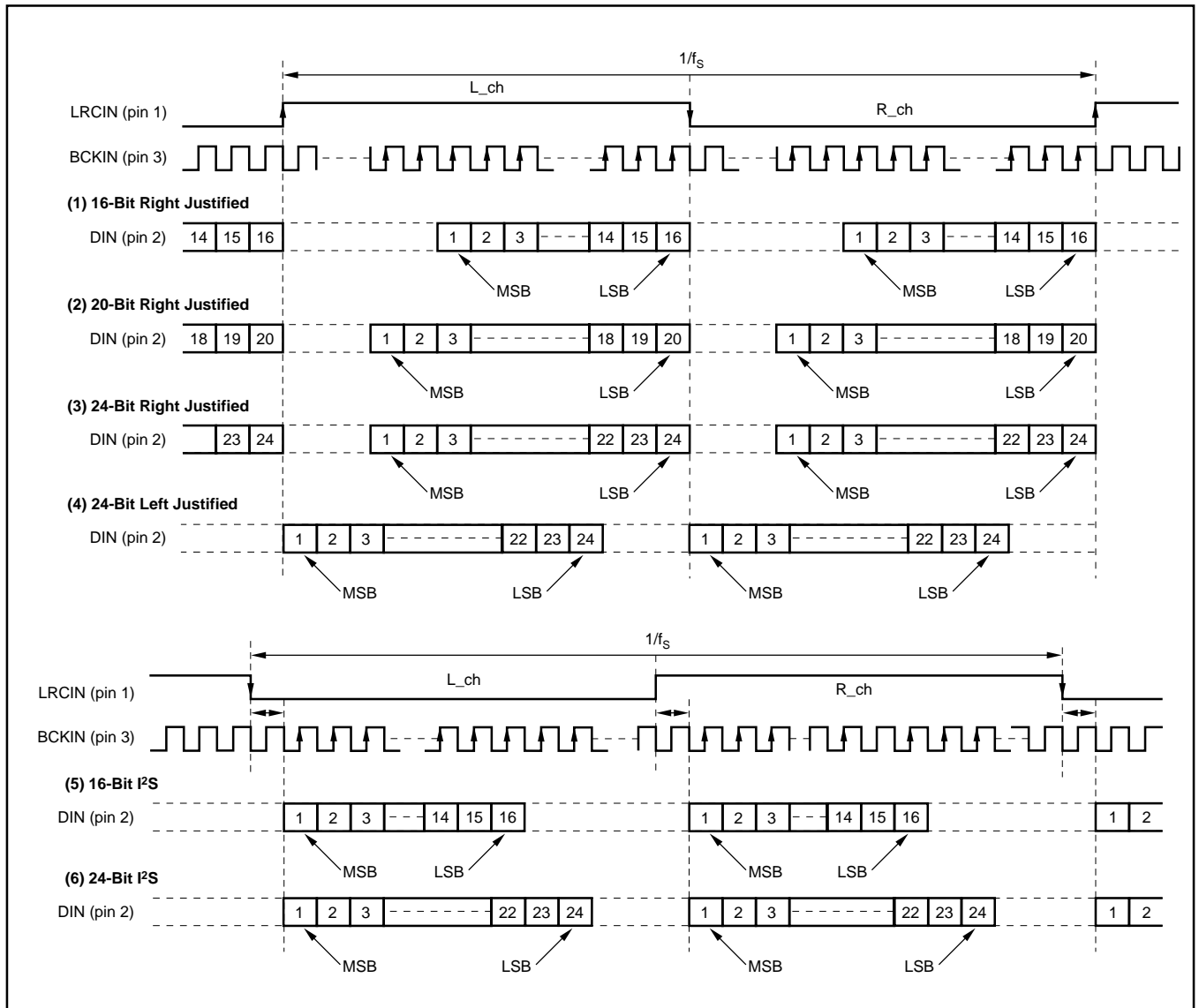

FIGURE 3. Audio Data Input Formats.

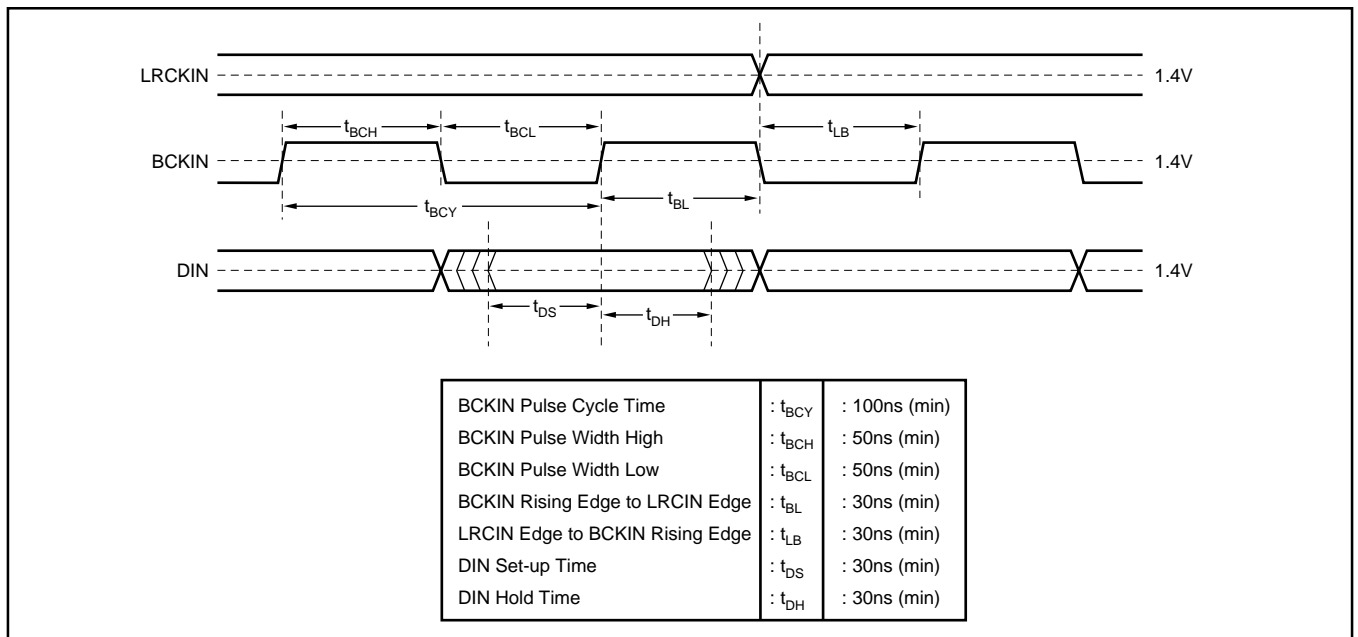

FIGURE 4. Audio Data Input Timing Specification.

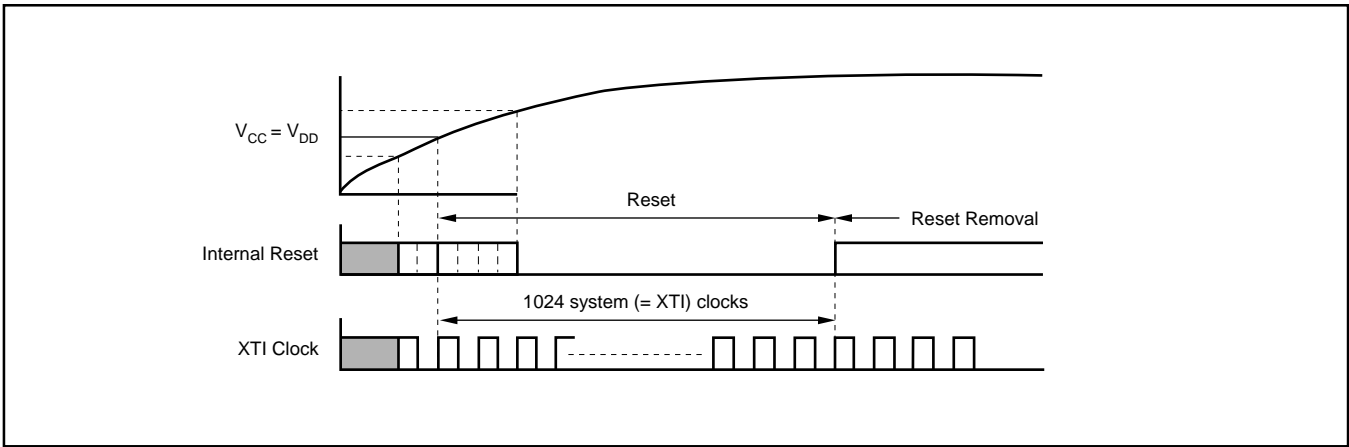

FIGURE 5. Internal Power-On Reset Timing.

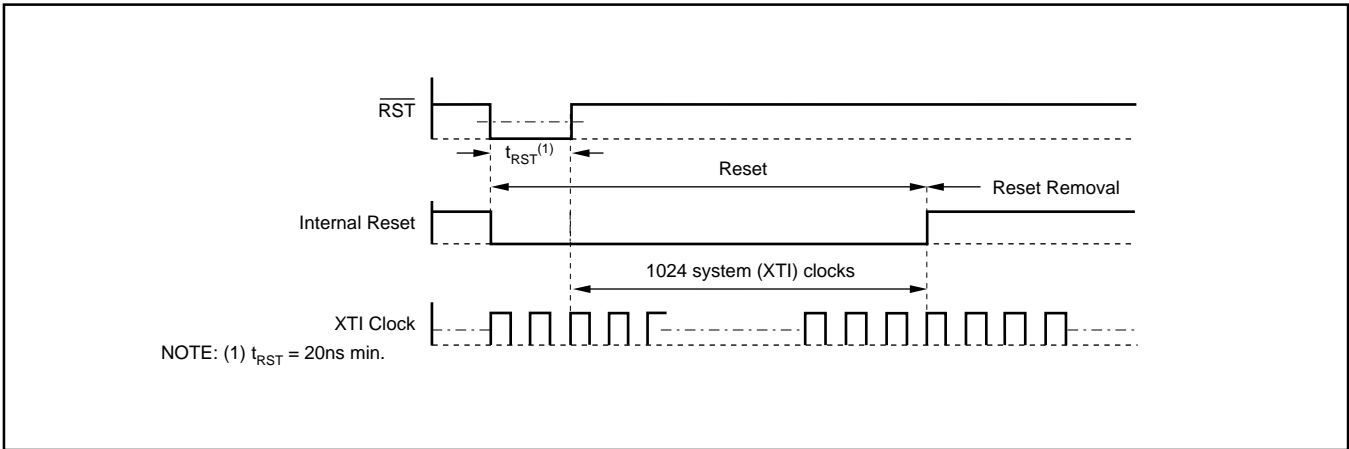

FIGURE 6. External Forced Reset Timing.

FUNCTIONAL DESCRIPTION

PCM1728 has several built-in functions including digital input data format selection, soft mute, and digital de-emphasis. These functions are hardware controlled where static control signals are used on pin 28 (I²S), pin 27 (DM1), pin 26 (DM0), pin 25 (MUTE), pin 24 (IW1), and pin 23 (IW0).

DATA FORMAL SELECTION

PCM audio data format can be selected by pin 28 (I²S), pin 24 (IW1), and pin 23 (IW0), as shown in Table II.

IW1	IW0	I ² S	AUDIO INTERFACE
0	0	0	16-Bit Standard, Right-Justified
0	1	0	20-Bit Standard, Right-Justified
1	0	0	24-Bit Standard, Right-Justified
1	1	0	24-Bit Left-Justified, MSB-First
0	0	1	16-Bit I ² S
0	1	1	24-Bit I ² S
1	0	1	Reserved
1	1	1	Reserved

TABLE II. Data Format Control.

SOFT MUTE

Soft Mute function can be controlled by $\overline{\text{MUTE}}$ (pin 25).

$\overline{\text{MUTE}}$ (Pin 25)	SOFT MUTE
L	Mute ON
H	Mute OFF (Normal Operation)

TABLE III. Soft Mute Control.

DE-EMPHASIS CONTROL

De-emphasis control can be selected by DM1 (pin 27) and DM0 (pin 26).

DM1 (Pin 27)	DM0 (Pin 26)	DE-EMPHASIS
L	L	OFF
L	H	48kHz
H	L	44.1kHz
H	H	32kHz

TABLE IV. De-emphasis Control.

THEORY OF OPERATION

The delta-sigma section of PCM1728 is based on an 8-level amplitude quantizer and a 4th-order noise shaper. This section converts the oversampled input data to 8-level delta-sigma format.

This newly developed, “Enhanced Multi-level Delta-Sigma” architecture achieves high-grade audio dynamic performance and sound quality.

A block diagram of the 8-level delta-sigma modulator is shown in Figure 7. This 8-level delta-sigma modulator has

the advantage of stability and clock jitter sensitivity over the typical one-bit (2-level) delta-sigma modulator.

The combined oversampling rate of the delta-sigma modulator and the internal 8-times interpolation filter is $64f_s$ for all system clock ratios ($256/384/512/768f_s$).

The theoretical quantization noise performance of the 8-level delta-sigma modulator is shown in Figure 8. This enhanced multi-level delta-sigma architecture also has advantages for input clock jitter sensitivity due to the multi-level quantizer, simulated jitter sensitivity is shown in Figure 9.

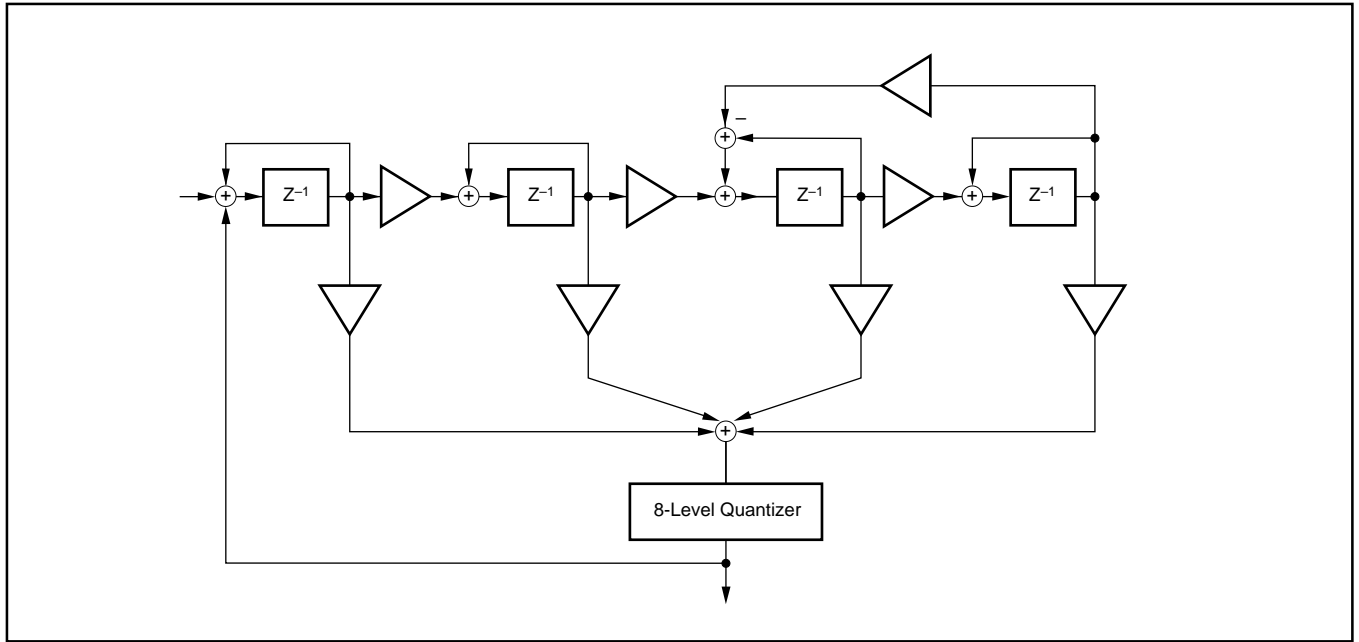

FIGURE 7. 8-Level Delta-Sigma Modulator.

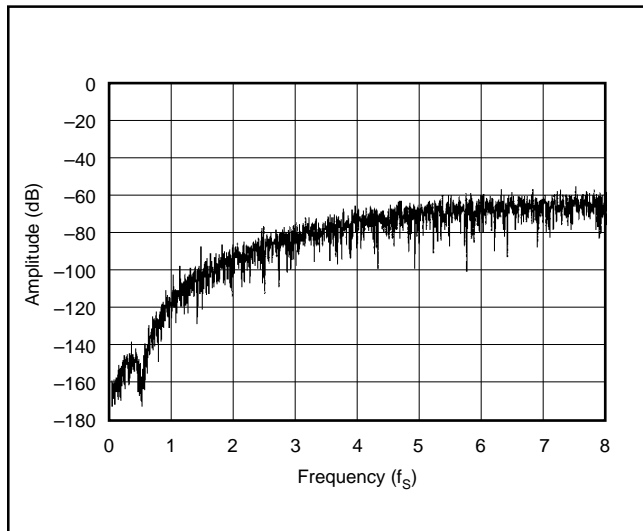

FIGURE 8. Quantization Noise Spectrum.

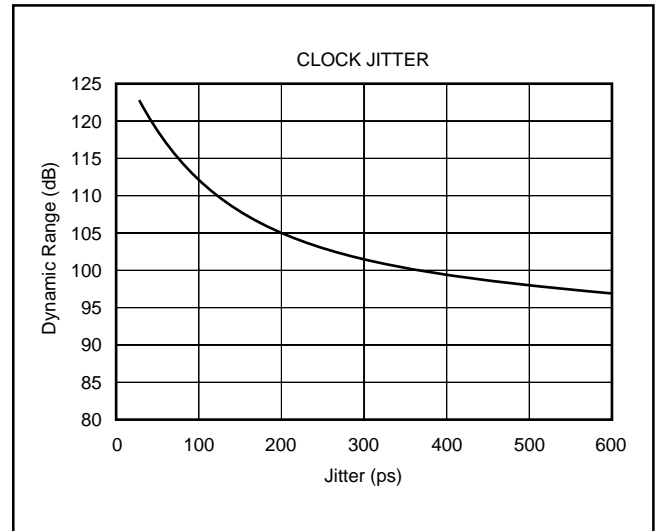

FIGURE 9. Jitter Sensitivity.

APPLICATION CONSIDERATIONS

DELAY TIME

There is a finite delay time in delta-sigma converters. In A/D converters, this is commonly referred to as latency. For a delta-sigma D/A converter, delay time is determined by the order number of the FIR filter stage, and the chosen sampling rate. The following equation expresses the delay time of PCM1728:

$$T_D = 30 \times 1/f_S$$

$$\text{For } f_S = 44.1\text{kHz, } T_D = 30/44.1\text{kHz} = 680\mu\text{s}$$

Applications using data from a disc or tape source, such as CD audio, DVD audio, Video CD, DAT, Minidisc, etc., generally are not affected by delay time. For some professional applications such as broadcast audio for studios, it is important for total delay time to be less than 2ms.

OUTPUT FILTERING

For testing purposes all dynamic tests are done on the PCM1728 using a 20kHz low pass filter. This filter limits the measured bandwidth for THD+N, etc. to 20kHz. Failure to use such a filter will result in higher THD+N and lower SNR and Dynamic Range readings than are found in the specifications. The low pass filter removes out of band noise. Although it is not audible, it may affect dynamic specification numbers.

The performance of the internal low pass filter from DC to 40kHz is shown in Figure 10. The higher frequency roll-off of the filter is shown in Figure 11. If the user's application has the PCM1728 driving a wideband amplifier, it is recommended to use an external low pass filter.

BYPASSING POWER SUPPLIES

The power supplies should be bypassed as close as possible to the unit. Refer to Figure 12 for optimal values of bypass capacitors.

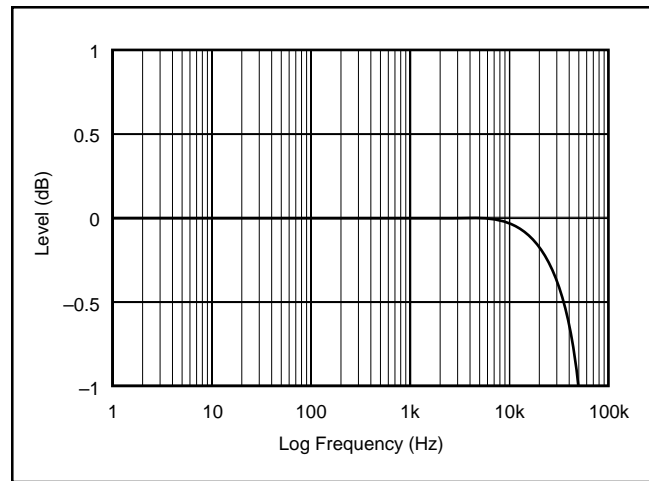

FIGURE 10. Low Pass Filter Response.

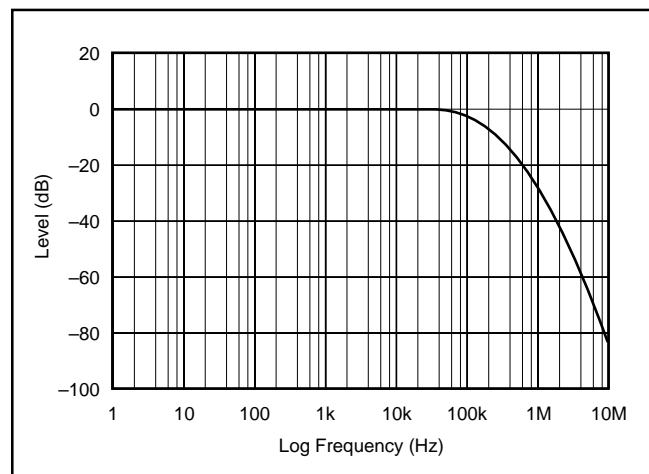

FIGURE 11. Low Pass Filter Response.

POWER SUPPLY CONNECTIONS

PCM1728 has four power supply pins for digital (V_{DD}), and analog (V_{CC}). Each connection also has a separate ground. If the power supplies turn on at different times, there is a possibility of a latch-up condition. To avoid this condition, it is recommended to have a common connection between the digital and analog power supplies. If separate supplies are used without a common connection, the delta between the two supplies during ramp-up time must be less than 0.1V.

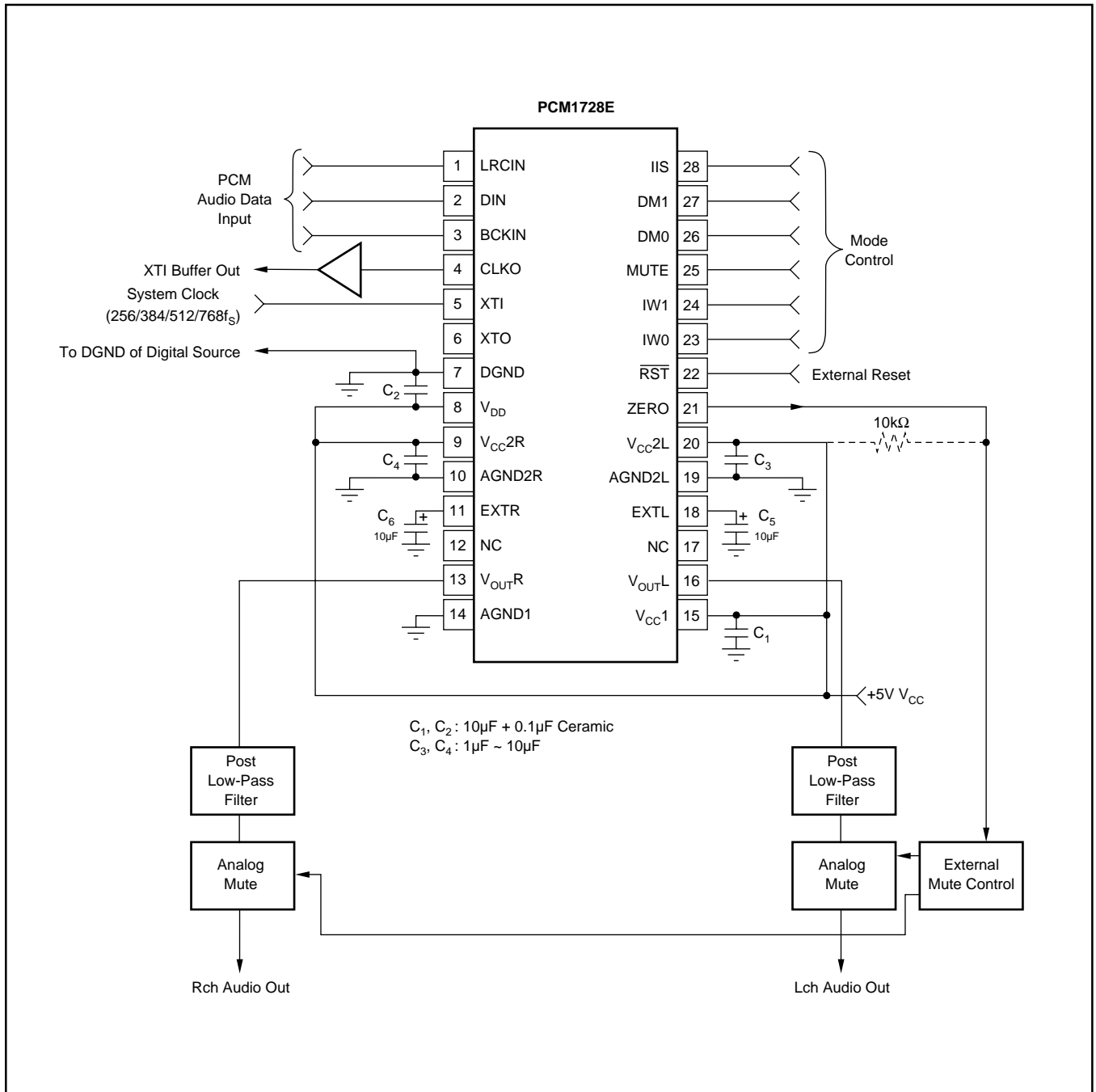

FIGURE 12. Typical Circuit Connection Diagram.

PACKAGING INFORMATION

Orderable Device	Status (1)	Package Type	Package Drawing	Pins	Package Qty	Eco Plan (2)	Lead/Ball Finish (6)	MSL Peak Temp (3)	Op Temp (°C)	Device Marking (4/5)	Samples
PCM1728E	NRND	SSOP	DB	28	47	Green (RoHS & no Sb/Br)	CU NIPDAU	Level-1-260C-UNLIM		PCM1728E	

(1) The marketing status values are defined as follows:

ACTIVE: Product device recommended for new designs.

LIFEBUY: TI has announced that the device will be discontinued, and a lifetime-buy period is in effect.

NRND: Not recommended for new designs. Device is in production to support existing customers, but TI does not recommend using this part in a new design.

PREVIEW: Device has been announced but is not in production. Samples may or may not be available.

OBSELETE: TI has discontinued the production of the device.

(2) **RoHS:** TI defines "RoHS" to mean semiconductor products that are compliant with the current EU RoHS requirements for all 10 RoHS substances, including the requirement that RoHS substance do not exceed 0.1% by weight in homogeneous materials. Where designed to be soldered at high temperatures, "RoHS" products are suitable for use in specified lead-free processes. TI may reference these types of products as "Pb-Free".

RoHS Exempt: TI defines "RoHS Exempt" to mean products that contain lead but are compliant with EU RoHS pursuant to a specific EU RoHS exemption.

Green: TI defines "Green" to mean the content of Chlorine (Cl) and Bromine (Br) based flame retardants meet JS709B low halogen requirements of <=1000ppm threshold. Antimony trioxide based flame retardants must also meet the <=1000ppm threshold requirement.

(3) MSL, Peak Temp. - The Moisture Sensitivity Level rating according to the JEDEC industry standard classifications, and peak solder temperature.

(4) There may be additional marking, which relates to the logo, the lot trace code information, or the environmental category on the device.

(5) Multiple Device Markings will be inside parentheses. Only one Device Marking contained in parentheses and separated by a "~" will appear on a device. If a line is indented then it is a continuation of the previous line and the two combined represent the entire Device Marking for that device.

(6) Lead/Ball Finish - Orderable Devices may have multiple material finish options. Finish options are separated by a vertical ruled line. Lead/Ball Finish values may wrap to two lines if the finish value exceeds the maximum column width.

Important Information and Disclaimer:The information provided on this page represents TI's knowledge and belief as of the date that it is provided. TI bases its knowledge and belief on information provided by third parties, and makes no representation or warranty as to the accuracy of such information. Efforts are underway to better integrate information from third parties. TI has taken and continues to take reasonable steps to provide representative and accurate information but may not have conducted destructive testing or chemical analysis on incoming materials and chemicals. TI and TI suppliers consider certain information to be proprietary, and thus CAS numbers and other limited information may not be available for release.

In no event shall TI's liability arising out of such information exceed the total purchase price of the TI part(s) at issue in this document sold by TI to Customer on an annual basis.

IMPORTANT NOTICE

Texas Instruments Incorporated (TI) reserves the right to make corrections, enhancements, improvements and other changes to its semiconductor products and services per JESD46, latest issue, and to discontinue any product or service per JESD48, latest issue. Buyers should obtain the latest relevant information before placing orders and should verify that such information is current and complete.

TI's published terms of sale for semiconductor products (<http://www.ti.com/sc/docs/stdterms.htm>) apply to the sale of packaged integrated circuit products that TI has qualified and released to market. Additional terms may apply to the use or sale of other types of TI products and services.

Reproduction of significant portions of TI information in TI data sheets is permissible only if reproduction is without alteration and is accompanied by all associated warranties, conditions, limitations, and notices. TI is not responsible or liable for such reproduced documentation. Information of third parties may be subject to additional restrictions. Resale of TI products or services with statements different from or beyond the parameters stated by TI for that product or service voids all express and any implied warranties for the associated TI product or service and is an unfair and deceptive business practice. TI is not responsible or liable for any such statements.

Buyers and others who are developing systems that incorporate TI products (collectively, "Designers") understand and agree that Designers remain responsible for using their independent analysis, evaluation and judgment in designing their applications and that Designers have full and exclusive responsibility to assure the safety of Designers' applications and compliance of their applications (and of all TI products used in or for Designers' applications) with all applicable regulations, laws and other applicable requirements. Designer represents that, with respect to their applications, Designer has all the necessary expertise to create and implement safeguards that (1) anticipate dangerous consequences of failures, (2) monitor failures and their consequences, and (3) lessen the likelihood of failures that might cause harm and take appropriate actions. Designer agrees that prior to using or distributing any applications that include TI products, Designer will thoroughly test such applications and the functionality of such TI products as used in such applications.

TI's provision of technical, application or other design advice, quality characterization, reliability data or other services or information, including, but not limited to, reference designs and materials relating to evaluation modules, (collectively, "TI Resources") are intended to assist designers who are developing applications that incorporate TI products; by downloading, accessing or using TI Resources in any way, Designer (individually or, if Designer is acting on behalf of a company, Designer's company) agrees to use any particular TI Resource solely for this purpose and subject to the terms of this Notice.

TI's provision of TI Resources does not expand or otherwise alter TI's applicable published warranties or warranty disclaimers for TI products, and no additional obligations or liabilities arise from TI providing such TI Resources. TI reserves the right to make corrections, enhancements, improvements and other changes to its TI Resources. TI has not conducted any testing other than that specifically described in the published documentation for a particular TI Resource.

Designer is authorized to use, copy and modify any individual TI Resource only in connection with the development of applications that include the TI product(s) identified in such TI Resource. NO OTHER LICENSE, EXPRESS OR IMPLIED, BY ESTOPPEL OR OTHERWISE TO ANY OTHER TI INTELLECTUAL PROPERTY RIGHT, AND NO LICENSE TO ANY TECHNOLOGY OR INTELLECTUAL PROPERTY RIGHT OF TI OR ANY THIRD PARTY IS GRANTED HEREIN, including but not limited to any patent right, copyright, mask work right, or other intellectual property right relating to any combination, machine, or process in which TI products or services are used. Information regarding or referencing third-party products or services does not constitute a license to use such products or services, or a warranty or endorsement thereof. Use of TI Resources may require a license from a third party under the patents or other intellectual property of the third party, or a license from TI under the patents or other intellectual property of TI.

TI RESOURCES ARE PROVIDED "AS IS" AND WITH ALL FAULTS. TI DISCLAIMS ALL OTHER WARRANTIES OR REPRESENTATIONS, EXPRESS OR IMPLIED, REGARDING RESOURCES OR USE THEREOF, INCLUDING BUT NOT LIMITED TO ACCURACY OR COMPLETENESS, TITLE, ANY EPIDEMIC FAILURE WARRANTY AND ANY IMPLIED WARRANTIES OF MERCHANTABILITY, FITNESS FOR A PARTICULAR PURPOSE, AND NON-INFRINGEMENT OF ANY THIRD PARTY INTELLECTUAL PROPERTY RIGHTS. TI SHALL NOT BE LIABLE FOR AND SHALL NOT DEFEND OR INDEMNIFY DESIGNER AGAINST ANY CLAIM, INCLUDING BUT NOT LIMITED TO ANY INFRINGEMENT CLAIM THAT RELATES TO OR IS BASED ON ANY COMBINATION OF PRODUCTS EVEN IF DESCRIBED IN TI RESOURCES OR OTHERWISE. IN NO EVENT SHALL TI BE LIABLE FOR ANY ACTUAL, DIRECT, SPECIAL, COLLATERAL, INDIRECT, PUNITIVE, INCIDENTAL, CONSEQUENTIAL OR EXEMPLARY DAMAGES IN CONNECTION WITH OR ARISING OUT OF TI RESOURCES OR USE THEREOF, AND REGARDLESS OF WHETHER TI HAS BEEN ADVISED OF THE POSSIBILITY OF SUCH DAMAGES.

Unless TI has explicitly designated an individual product as meeting the requirements of a particular industry standard (e.g., ISO/TS 16949 and ISO 26262), TI is not responsible for any failure to meet such industry standard requirements.

Where TI specifically promotes products as facilitating functional safety or as compliant with industry functional safety standards, such products are intended to help enable customers to design and create their own applications that meet applicable functional safety standards and requirements. Using products in an application does not by itself establish any safety features in the application. Designers must ensure compliance with safety-related requirements and standards applicable to their applications. Designer may not use any TI products in life-critical medical equipment unless authorized officers of the parties have executed a special contract specifically governing such use. Life-critical medical equipment is medical equipment where failure of such equipment would cause serious bodily injury or death (e.g., life support, pacemakers, defibrillators, heart pumps, neurostimulators, and implantables). Such equipment includes, without limitation, all medical devices identified by the U.S. Food and Drug Administration as Class III devices and equivalent classifications outside the U.S.

TI may expressly designate certain products as completing a particular qualification (e.g., Q100, Military Grade, or Enhanced Product). Designers agree that it has the necessary expertise to select the product with the appropriate qualification designation for their applications and that proper product selection is at Designers' own risk. Designers are solely responsible for compliance with all legal and regulatory requirements in connection with such selection.

Designer will fully indemnify TI and its representatives against any damages, costs, losses, and/or liabilities arising out of Designer's non-compliance with the terms and provisions of this Notice.

Looking for pricing, stock, or lifecycle information?

Click below to explore more details on WIN SOURCE:

 [View PCM1728E/2K on WIN SOURCE](#)

 [Texas Instruments](#) Information

Optimize Your Supply Chain with WIN SOURCE Solutions

-  Global Sourcing Solution
-  Obsolete Management
-  Cost Control Management
-  Shortage Management
-  Alternative Solution
-  Excess Inventory Management