

DATA SHEET

PDTA143E series

PNP resistor-equipped transistors;

R1 = 4.7 k Ω , R2 = 4.7 k Ω

Product specification
Supersedes data of 2003 Sep 08

2004 Aug 04

PNP resistor-equipped transistors; R1 = 4.7 k Ω , R2 = 4.7 k Ω

PDTA143E series

FEATURES

- Built-in bias resistors
- Simplified circuit design
- Reduction of component count
- Reduced pick and place costs.

APPLICATIONS

- General purpose switching and amplification
- Inverter and interface circuits
- Circuit driver.

QUICK REFERENCE DATA

SYMBOL	PARAMETER	TYP.	MAX.	UNIT
V _{CEO}	collector-emitter voltage	–	–50	V
I _O	output current (DC)	–	–100	mA
R1	bias resistor	4.7	–	k Ω
R2	bias resistor	4.7	–	k Ω

DESCRIPTION

PNP resistor-equipped transistor (see “Simplified outline, symbol and pinning” for package details).

PRODUCT OVERVIEW

TYPE NUMBER	PACKAGE		MARKING CODE	NPN COMPLEMENT
	PHILIPS	EIAJ		
PDTA143EE	SOT416	SC-75	01	PDTC143EE
PDTA143EEF	SOT490	SC-89	50	PDTC143EEF
PDTA143EK	SOT346	SC-59	01	PDTC143EK
PDTA143EM	SOT883	SC-101	DL	PDTC143EM
PDTA143ES	SOT54 (TO-92)	SC-43	TA143E	PDTC143ES
PDTA143ET	SOT23	–	*01 ⁽¹⁾	PDTC143ET
PDTA143EU	SOT323	SC-70	*01 ⁽¹⁾	PDTC143EU

Note

1. * = p: Made in Hong Kong.
* = t: Made in Malaysia.
* = W: Made in China.

PNP resistor-equipped transistors;
 R1 = 4.7 kΩ, R2 = 4.7 kΩ

PDTA143E series

SIMPLIFIED OUTLINE, SYMBOL AND PINNING

TYPE NUMBER	SIMPLIFIED OUTLINE AND SYMBOL	PINNING	
		PIN	DESCRIPTION
PDTA143ES	<p>MAM338</p>	1 2 3	base collector emitter
PDTA143EE PDTA143EEF PDTA143EK PDTA143ET PDTA143EU	<p>Top view</p> <p>MDB271</p>	1 2 3	base emitter collector
PDTA143EM	<p>Bottom view</p> <p>MDB267</p>	1 2 3	base emitter collector

PNP resistor-equipped transistors;
R1 = 4.7 k Ω , R2 = 4.7 k Ω

PDTA143E series

LIMITING VALUES

In accordance with the Absolute Maximum Rating System (IEC 60134).

SYMBOL	PARAMETER	CONDITIONS	MIN.	MAX.	UNIT
V _{CBO}	collector-base voltage	open emitter	–	–50	V
V _{CEO}	collector-emitter voltage	open base	–	–50	V
V _{EBO}	emitter-base voltage	open collector	–	–10	V
V _I	input voltage				
		positive	–	+10	V
	negative		–	–30	V
I _O	output current (DC)		–	–100	mA
I _{CM}	peak collector current		–	–100	mA
P _{tot}	total power dissipation	T _{amb} ≤ 25 °C			
	SOT23	note 1	–	250	mW
	SOT54	note 1	–	500	mW
	SOT323	note 1	–	200	mW
	SOT346	note 1	–	250	mW
	SOT416	note 1	–	150	mW
	SOT490	notes 1 and 2	–	250	mW
SOT883	notes 2 and 3	–	250	mW	
T _{stg}	storage temperature		–65	+150	°C
T _j	junction temperature		–	150	°C
T _{amb}	operating ambient temperature		–65	+150	°C

Notes

1. Refer to standard mounting conditions.
2. Reflow soldering is the only recommended soldering method.
3. Refer to SOT883 standard mounting conditions; FR4 with 60 μ m copper strip line.

THERMAL CHARACTERISTICS

SYMBOL	PARAMETER	CONDITIONS	VALUE	UNIT
R _{th j-a}	thermal resistance from junction to ambient	in free air		
	SOT23	note 1	500	K/W
	SOT54	note 1	250	K/W
	SOT323	note 1	625	K/W
	SOT346	note 1	500	K/W
	SOT416	note 1	833	K/W
	SOT490	notes 1 and 2	500	K/W
SOT883	notes 2 and 3	500	K/W	

Notes

1. Refer to standard mounting conditions.
2. Reflow soldering is the only recommended soldering method.
3. Refer to SOT883 standard mounting conditions; FR4 with 60 μ m copper strip line.

PNP resistor-equipped transistors;
 $R1 = 4.7 \text{ k}\Omega$, $R2 = 4.7 \text{ k}\Omega$

PDTA143E series

CHARACTERISTICS

$T_{\text{amb}} = 25 \text{ }^\circ\text{C}$ unless otherwise specified.

SYMBOL	PARAMETER	CONDITIONS	MIN.	TYP.	MAX.	UNIT
I_{CBO}	collector-base cut-off current	$V_{\text{CB}} = -50 \text{ V}$; $I_{\text{E}} = 0$	–	–	–100	nA
I_{CEO}	collector-emitter cut-off current	$V_{\text{CE}} = -30 \text{ V}$; $I_{\text{B}} = 0$	–	–	–1	μA
		$V_{\text{CE}} = -30 \text{ V}$; $I_{\text{B}} = 0$; $T_{\text{j}} = 150 \text{ }^\circ\text{C}$	–	–	–50	μA
I_{EBO}	emitter-base cut-off current	$V_{\text{EB}} = -5 \text{ V}$; $I_{\text{C}} = 0$	–	–	–0.9	mA
h_{FE}	DC current gain	$V_{\text{CE}} = -5 \text{ V}$; $I_{\text{C}} = -10 \text{ mA}$	30	–	–	
V_{CEsat}	collector-emitter saturation voltage	$I_{\text{C}} = -10 \text{ mA}$; $I_{\text{B}} = -0.5 \text{ mA}$	–	–	–150	mV
$V_{\text{i(off)}}$	input-off voltage	$I_{\text{C}} = -100 \mu\text{A}$; $V_{\text{CE}} = -5 \text{ V}$	–	–1.1	–0.5	V
$V_{\text{i(on)}}$	input-on voltage	$I_{\text{C}} = -20 \text{ mA}$; $V_{\text{CE}} = -0.3 \text{ V}$	–2.5	–1.9	–	V
R1	input resistor		3.3	4.7	6.1	$\text{k}\Omega$
$\frac{R2}{R1}$	resistor ratio		0.8	1	1.2	
C_{c}	collector capacitance	$I_{\text{E}} = i_{\text{e}} = 0$; $V_{\text{CB}} = -10 \text{ V}$; $f = 1 \text{ MHz}$	–	–	3	pF

PNP resistor-equipped transistors;
R1 = 4.7 kΩ, R2 = 4.7 kΩ

PDTA143E series

PACKAGE OUTLINES

Plastic surface mounted package; 3 leads

SOT23

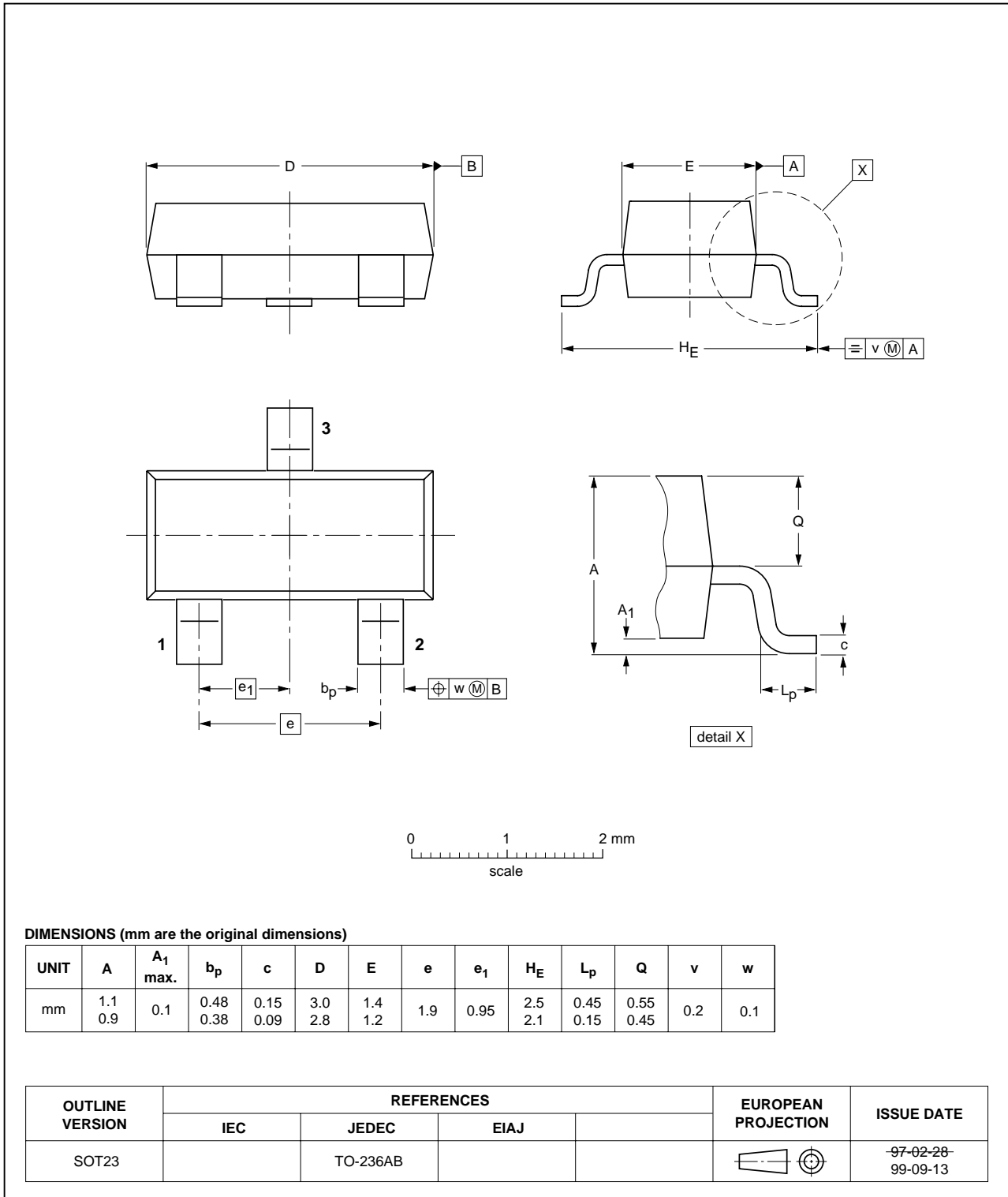

PNP resistor-equipped transistors;
R1 = 4.7 kΩ, R2 = 4.7 kΩ

PDTA143E series

Plastic single-ended leaded (through hole) package; 3 leads

SOT54

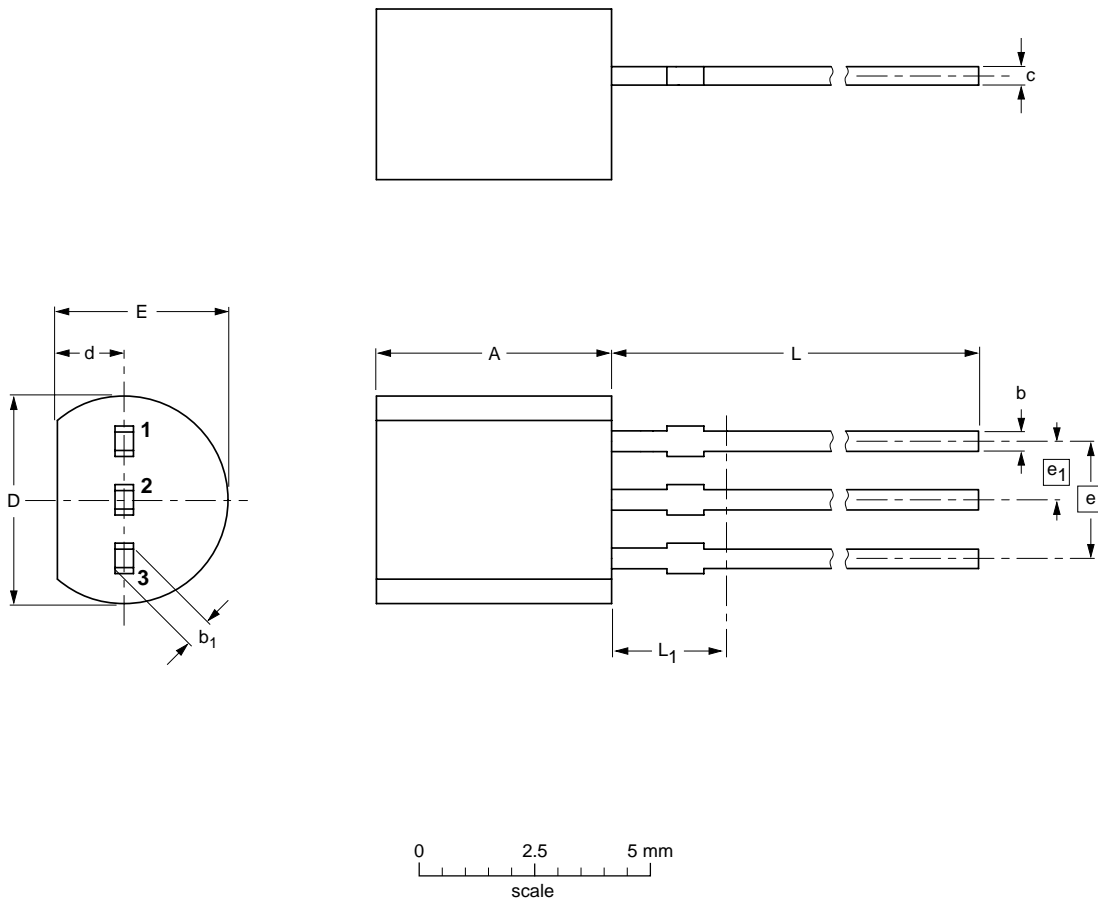

DIMENSIONS (mm are the original dimensions)

UNIT	A	b	b ₁	c	D	d	E	e	e ₁	L	L ₁ ⁽¹⁾ max.
mm	5.2 5.0	0.48 0.40	0.66 0.55	0.45 0.38	4.8 4.4	1.7 1.4	4.2 3.6	2.54	1.27	14.5 12.7	2.5

Note

1. Terminal dimensions within this zone are uncontrolled to allow for flow of plastic and terminal irregularities.

OUTLINE VERSION	REFERENCES			EUROPEAN PROJECTION	ISSUE DATE
	IEC	JEDEC	JEITA		
SOT54		TO-92	SC-43A		97-02-28 04-06-28

PNP resistor-equipped transistors;
R1 = 4.7 kΩ, R2 = 4.7 kΩ

PDTA143E series

Plastic surface mounted package; 3 leads

SOT323

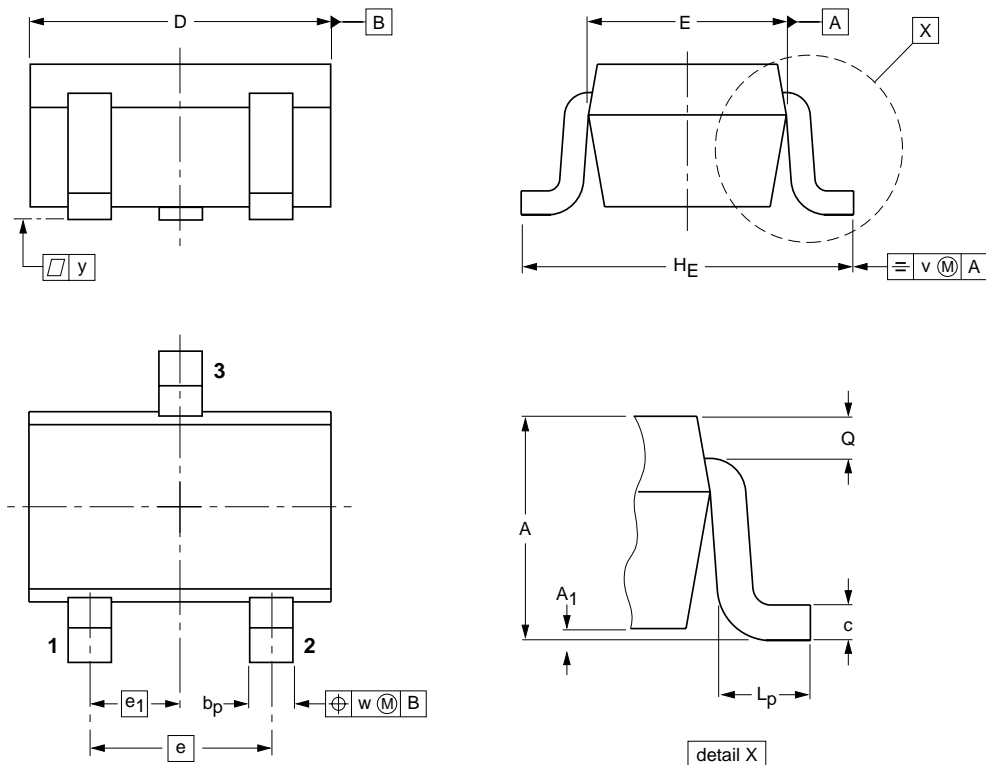

DIMENSIONS (mm are the original dimensions)

UNIT	A	A ₁ max	b _p	c	D	E	e	e ₁	H _E	L _p	Q	v	w
mm	1.1 0.8	0.1	0.4 0.3	0.25 0.10	2.2 1.8	1.35 1.15	1.3	0.65	2.2 2.0	0.45 0.15	0.23 0.13	0.2	0.2

OUTLINE VERSION	REFERENCES				EUROPEAN PROJECTION	ISSUE DATE
	IEC	JEDEC	EIAJ			
SOT323			SC-70			97-02-28

PNP resistor-equipped transistors;
R1 = 4.7 kΩ, R2 = 4.7 kΩ

PDTA143E series

Plastic surface mounted package; 3 leads

SOT346

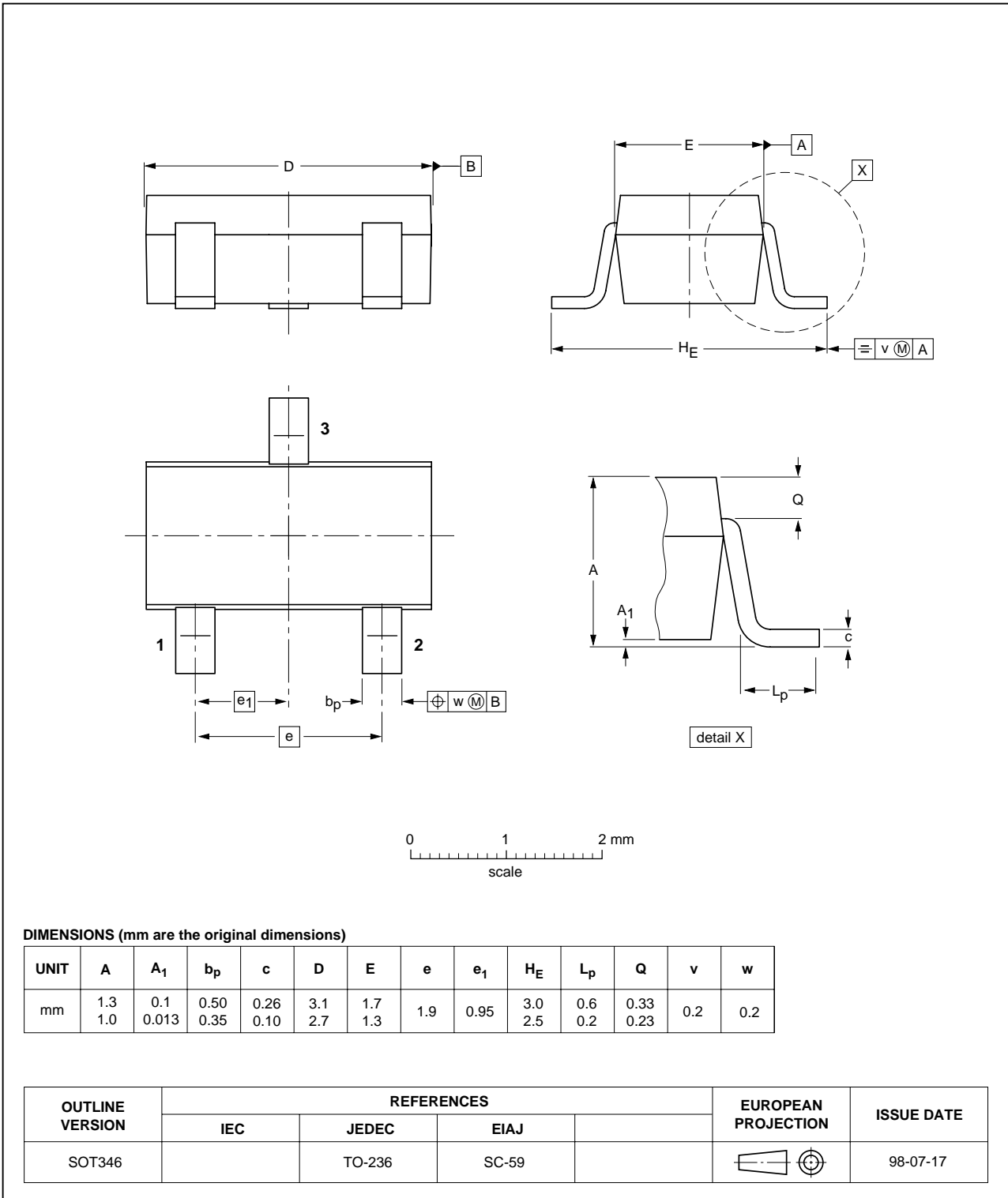

PNP resistor-equipped transistors;
R1 = 4.7 kΩ, R2 = 4.7 kΩ

PDTA143E series

Plastic surface mounted package; 3 leads

SOT416

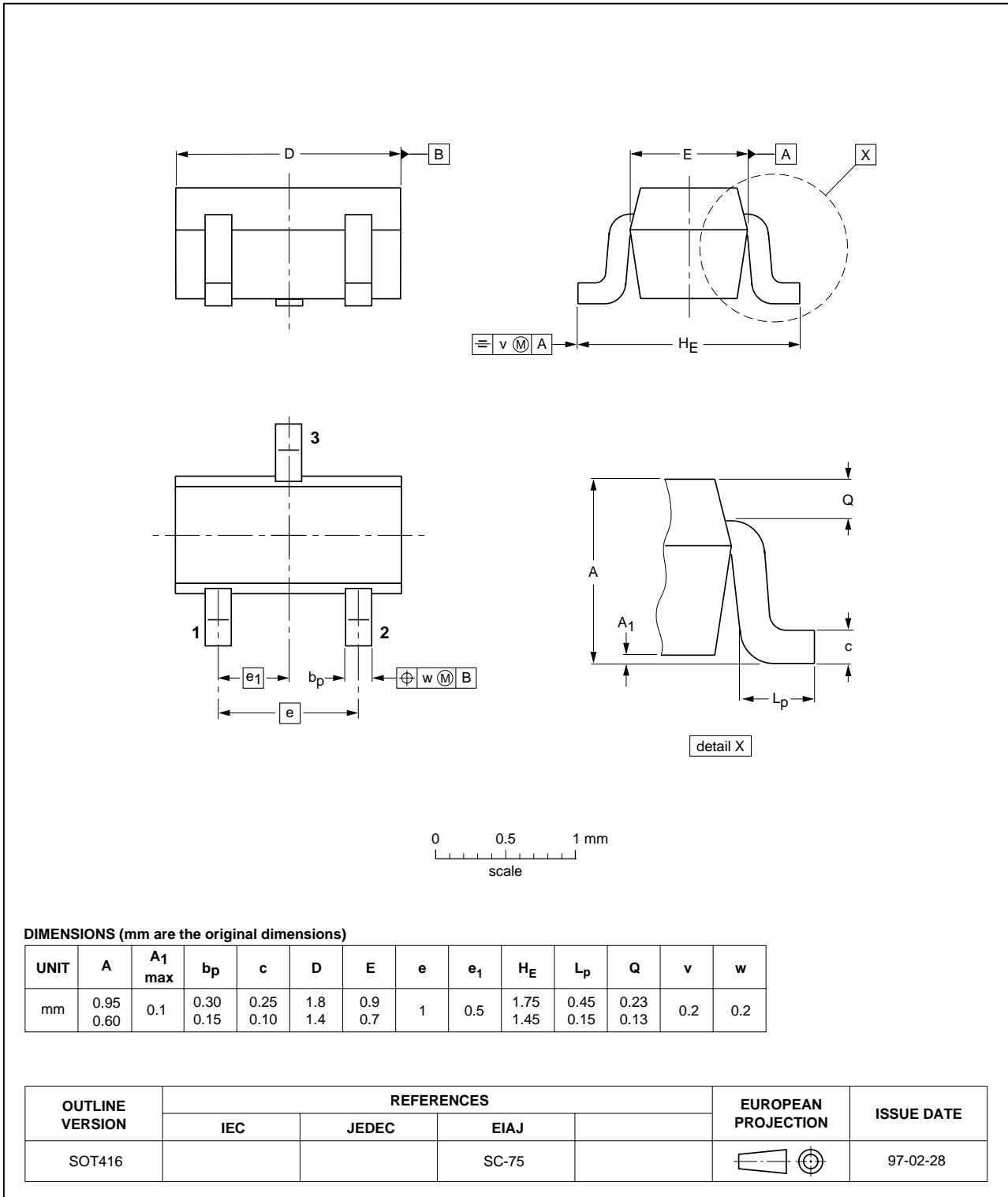

PNP resistor-equipped transistors;
R1 = 4.7 kΩ, R2 = 4.7 kΩ

PDTA143E series

Plastic surface mounted package; 3 leads

SOT490

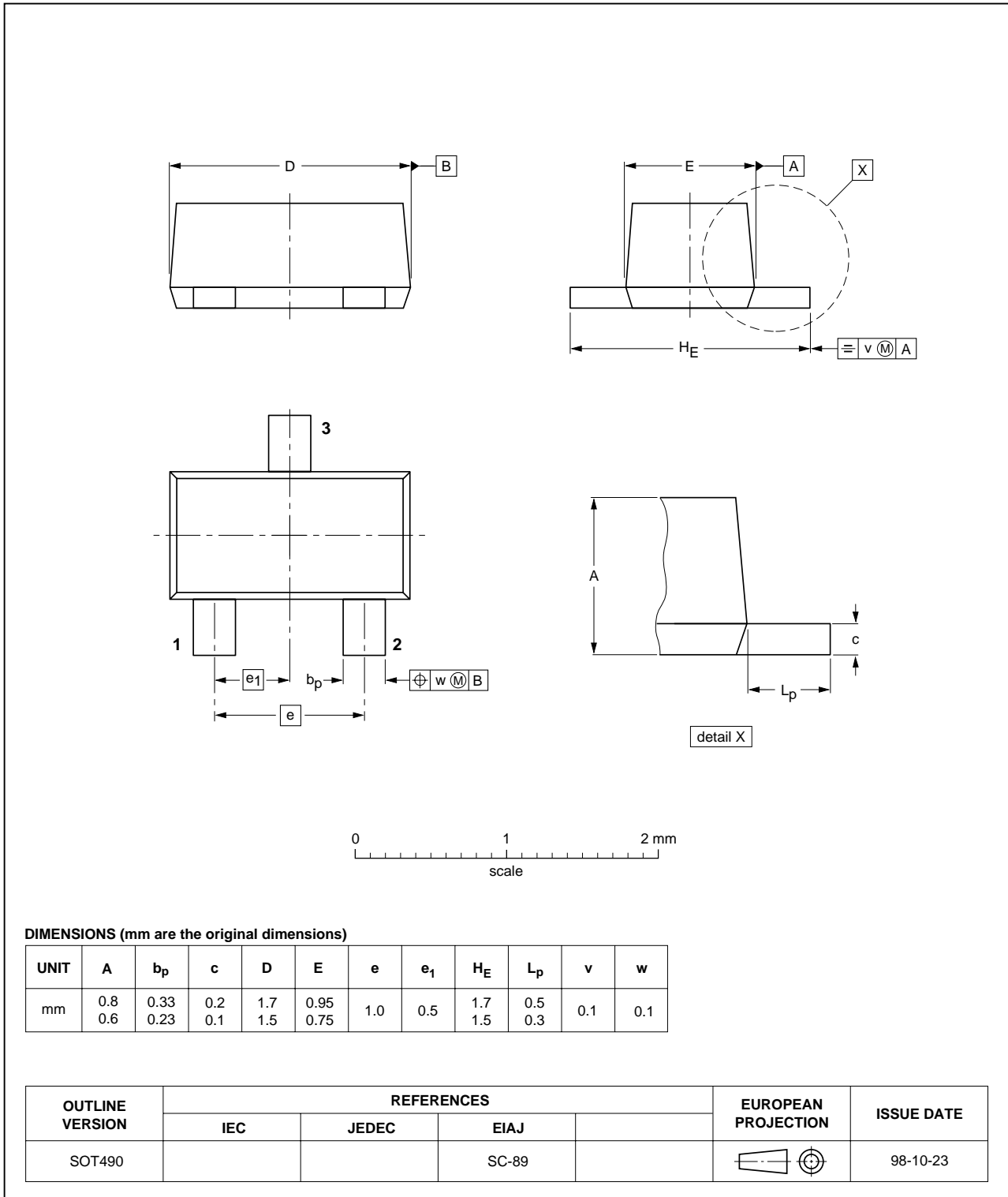

PNP resistor-equipped transistors;
R1 = 4.7 kΩ, R2 = 4.7 kΩ

PDTA143E series

Leadless ultra small plastic package; 3 solder lands; body 1.0 x 0.6 x 0.5 mm

SOT883

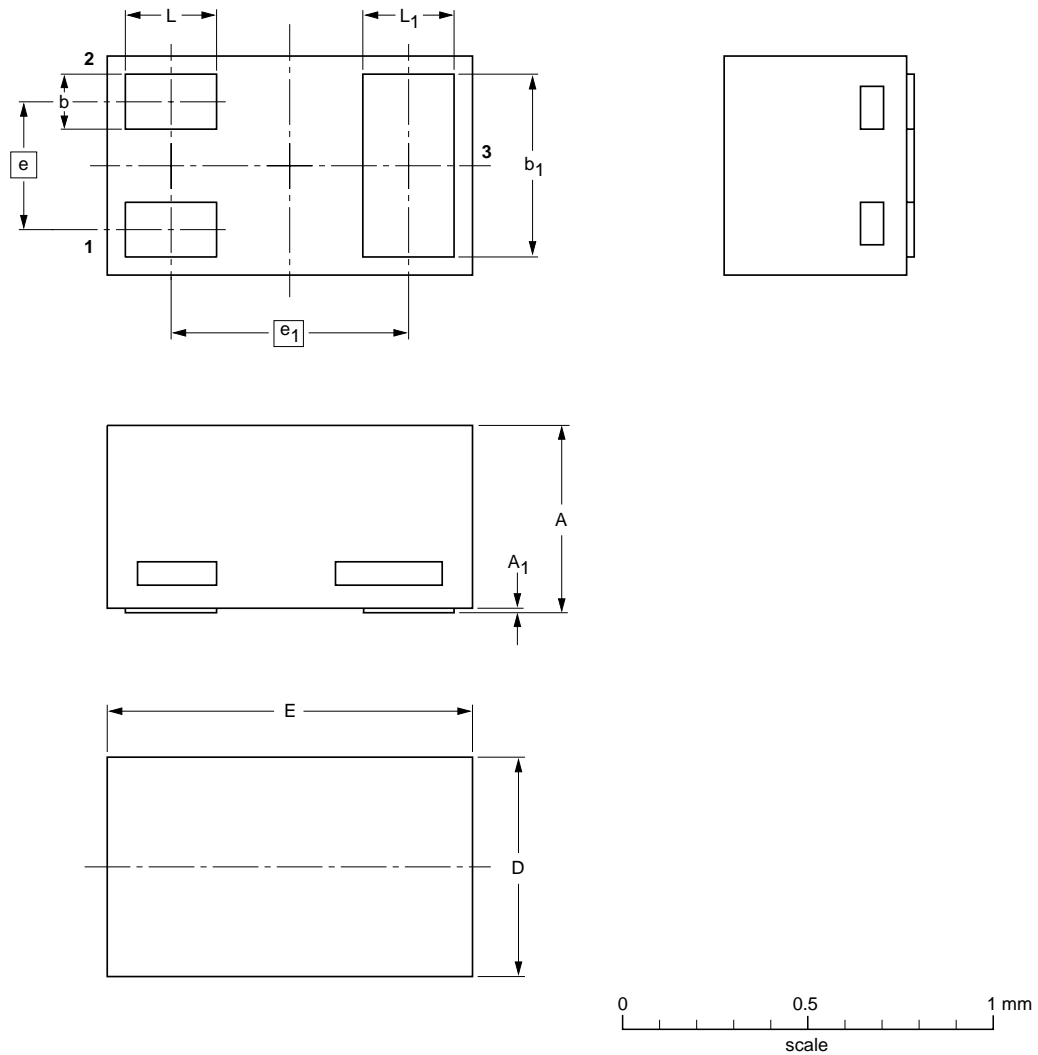

DIMENSIONS (mm are the original dimensions)

UNIT	A ⁽¹⁾	A ₁ max.	b	b ₁	D	E	e	e ₁	L	L ₁
mm	0.50 0.46	0.03	0.20 0.12	0.55 0.47	0.62 0.55	1.02 0.95	0.35	0.65	0.30 0.22	0.30 0.22

Note

1. Including plating thickness

OUTLINE VERSION	REFERENCES			EUROPEAN PROJECTION	ISSUE DATE
	IEC	JEDEC	JEITA		
SOT883			SC-101		03-02-05 03-04-03

PNP resistor-equipped transistors;
R1 = 4.7 k Ω , R2 = 4.7 k Ω

PDTA143E series

DATA SHEET STATUS

LEVEL	DATA SHEET STATUS ⁽¹⁾	PRODUCT STATUS ⁽²⁾⁽³⁾	DEFINITION
I	Objective data	Development	This data sheet contains data from the objective specification for product development. Philips Semiconductors reserves the right to change the specification in any manner without notice.
II	Preliminary data	Qualification	This data sheet contains data from the preliminary specification. Supplementary data will be published at a later date. Philips Semiconductors reserves the right to change the specification without notice, in order to improve the design and supply the best possible product.
III	Product data	Production	This data sheet contains data from the product specification. Philips Semiconductors reserves the right to make changes at any time in order to improve the design, manufacturing and supply. Relevant changes will be communicated via a Customer Product/Process Change Notification (CPCN).

Notes

1. Please consult the most recently issued data sheet before initiating or completing a design.
2. The product status of the device(s) described in this data sheet may have changed since this data sheet was published. The latest information is available on the Internet at URL <http://www.semiconductors.philips.com>.
3. For data sheets describing multiple type numbers, the highest-level product status determines the data sheet status.

DEFINITIONS

Short-form specification — The data in a short-form specification is extracted from a full data sheet with the same type number and title. For detailed information see the relevant data sheet or data handbook.

Limiting values definition — Limiting values given are in accordance with the Absolute Maximum Rating System (IEC 60134). Stress above one or more of the limiting values may cause permanent damage to the device. These are stress ratings only and operation of the device at these or at any other conditions above those given in the Characteristics sections of the specification is not implied. Exposure to limiting values for extended periods may affect device reliability.

Application information — Applications that are described herein for any of these products are for illustrative purposes only. Philips Semiconductors make no representation or warranty that such applications will be suitable for the specified use without further testing or modification.

DISCLAIMERS

Life support applications — These products are not designed for use in life support appliances, devices, or systems where malfunction of these products can reasonably be expected to result in personal injury. Philips Semiconductors customers using or selling these products for use in such applications do so at their own risk and agree to fully indemnify Philips Semiconductors for any damages resulting from such application.

Right to make changes — Philips Semiconductors reserves the right to make changes in the products - including circuits, standard cells, and/or software - described or contained herein in order to improve design and/or performance. When the product is in full production (status 'Production'), relevant changes will be communicated via a Customer Product/Process Change Notification (CPCN). Philips Semiconductors assumes no responsibility or liability for the use of any of these products, conveys no licence or title under any patent, copyright, or mask work right to these products, and makes no representations or warranties that these products are free from patent, copyright, or mask work right infringement, unless otherwise specified.

Philips Semiconductors – a worldwide company

Contact information

For additional information please visit <http://www.semiconductors.philips.com>. Fax: +31 40 27 24825

For sales offices addresses send e-mail to: sales.addresses@www.semiconductors.philips.com.

© Koninklijke Philips Electronics N.V. 2004

SCA76

All rights are reserved. Reproduction in whole or in part is prohibited without the prior written consent of the copyright owner.

The information presented in this document does not form part of any quotation or contract, is believed to be accurate and reliable and may be changed without notice. No liability will be accepted by the publisher for any consequence of its use. Publication thereof does not convey nor imply any license under patent- or other industrial or intellectual property rights.

Printed in The Netherlands

R75/07/pp14

Date of release: 2004 Aug 04

Document order number: 9397 750 13655

Let's make things better.



**Philips
Semiconductors**



PHILIPS

Looking for pricing, stock, or lifecycle information?

Click below to explore more details on WIN SOURCE:

-  [View PDTA143EK on WIN SOURCE](#)
-  [NXP / Nexperia Information](#)

Optimize Your Supply Chain with WIN SOURCE Solutions

-  Global Sourcing Solution
-  Obsolete Management
-  Cost Control Management
-  Shortage Management
-  Alternative Solution
-  Excess Inventory Management