



**THE DATASHEET OF
PI3L500ZFE**



3.3V, 8-Channel, 2:1 Mux/DeMux Gigabit Ethernet LAN Switch with Single Enable

Features

- R_{ON} is 4Ω (typical)
- Low bit-to-bit skew: 200ps
- Low Crosstalk: -22dB @ 250 MHz
- Near-Zero propagation delay: 250ps
- Switching speed: 9ns
- Channel On capacitance: 10pF (typical)
- Live Insertion Capable
- Status Indicator LEDs Switched with Ethernet pairs
- V_{CC} Operating Range: +3.0V to +3.6V
- $>3\text{kV}$ ESD protection (human body model)
- $>350\text{ MHz}$ bandwidth (or data frequency)
- Packaging (Pb-free and Green available):
 - 56-contact TQFN (ZF)

Description

The PI3L500 is a 16- to 8-Channel multiplexer/demultiplexer LAN Switch with Hi-Z outputs. Industry leading advantages include a propagation delay of less than 250ps, resulting from its low channel resistance and I/O capacitance.

The device multiplexes differential outputs from a Gigabit Ethernet transceiver (PHY) device to one of two corresponding B1 or B2 outputs. The switch is bidirectional and offers little or no attenuation of the high-speed signals at the outputs. It is designed for low bit-to-bit skew, high channel-to-channel noise isolation and is compatible with various standards, such as 10/100/1000 Base-T (Ethernet).

Generally, this part can be used to replace mechanical relays in low-voltage LAN applications that interface a physical layer over CAT 5 or CAT 6 unshielded twisted pair cable through an isolation transformer.

Applications

- Dual Physical Layer Device sharing to one interface connector
- Routes signals for 10/100/1000 Mbit Ethernet

Block Diagram

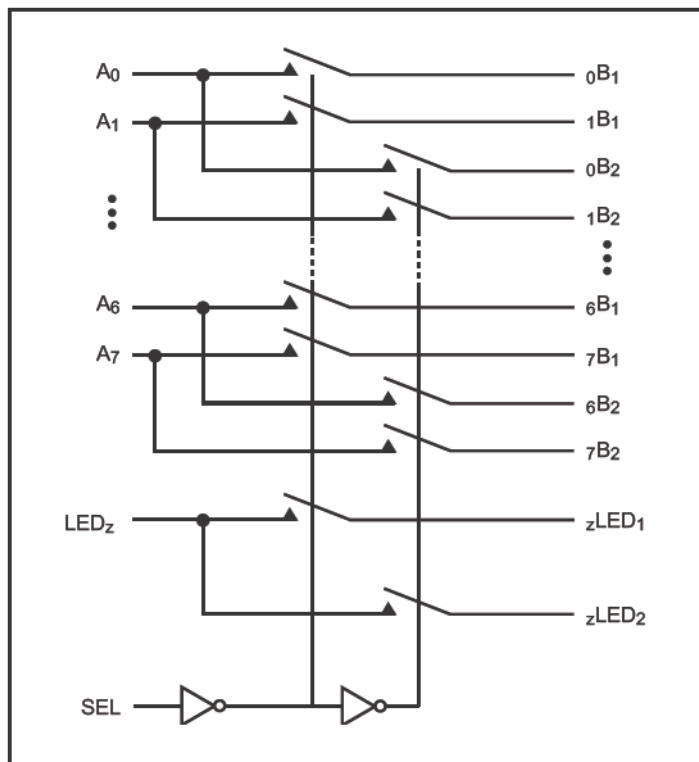

Pin Description

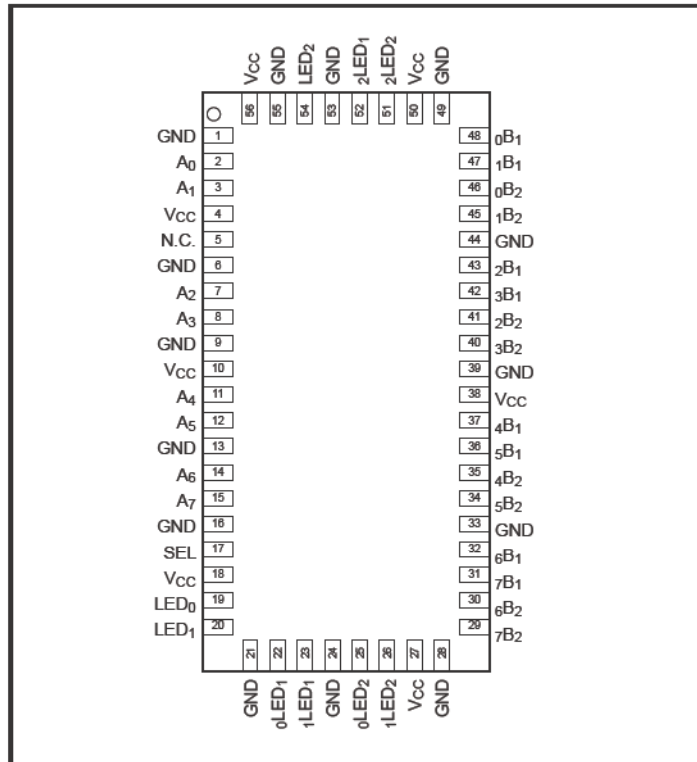

Pin Description

Pin Name	Description
A _X	Demux Inputs
xB _Y	Mux Inputs
LED _Z	LED Demux Inputs
zLED _Y	LED Mux Inputs
GND	Ground
V _{CC}	Power
SEL	Select

Truth Table

SEL	Function
L	A _X to xB ₁ ; LED _Z to zLED ₁
H	A _X to xB ₂ ; LED _Z to zLED ₂

Maximum Ratings

(Above which useful life may be impaired. For user guidelines, not tested.)

Storage Temperature.....	-65°C to +150°C
Supply Voltage to Ground Potential	-0.5V to +4.0V
DC Input Voltage.....	-0.5V to +5.5V
DC Output Current.....	120mA
Power Dissipation	0.5W

Note:

Stresses greater than those listed under MAXIMUM RATINGS may cause permanent damage to the device. This is a stress rating only and functional operation of the device at these or any other conditions above those indicated in the operational sections of this specification is not implied. Exposure to absolute maximum rating conditions for extended periods may affect reliability.

DC Electrical Characteristics for 1000 Base-T Ethernet Switching over Operating Range

($T_A = -40^{\circ}\text{C}$ to $+85^{\circ}\text{C}$, $V_{CC} = 3.3\text{V} \pm 10\%$)

Parameter	Description	Test Conditions ⁽¹⁾	Min.	Typ. ⁽²⁾	Max.	Units
V_{IH}	Input HIGH Voltage	Guaranteed HIGH level (Control Pins)	2.0			V
V_{IL}	Input LOW Voltage	Guaranteed LOW level (Control Pins)	-0.5		0.8	
V_{IK}	Clamp Diode Voltage	$V_{CC} = \text{Max.}, I_{IN} = -18\text{mA}$		-0.7	-1.2	
I_{IH}	Input HIGH Current	$V_{CC} = \text{Max.}, V_{IN} = V_{CC}$			± 5	μA
I_{IL}	Input LOW Current	$V_{CC} = \text{Max.}, V_{IN} = \text{GND}$			± 5	
R_{ON}	Switch On-Resistance ⁽³⁾	$V_{CC} = \text{Min.}, 1.5\text{V} \leq V_{IN} \leq V_{CC}$ $I_{IN} = -40\text{mA}$		4.0	6.5	Ω
$R_{FLAT(ON)}$	On-Resistance Flatness ⁽³⁾	$V_{CC} = \text{Min.}, V_{IN} @ 1.5\text{V}$ and V_{CC} $I_{IN} = -40\text{mA}$		0.5		
ΔR_{ON}	On-Resistance match from center ports to any other port ⁽³⁾	$V_{CC} = \text{Min.}, 1.5\text{V} \leq V_{IN} \leq V_{CC}$ $I_{IN} = -40\text{mA}$		0.4	1.0	

Notes:

1. For max. or min. conditions, use appropriate value specified under Electrical Characteristics for the applicable device type.
2. Typical values are at $V_{CC} = 3.3\text{V}$, $T_A = 25^{\circ}\text{C}$ ambient and maximum loading.
3. Measured by the voltage drop between A and B pins at indicated current through the switch. ON resistance is determined by the lower of the voltages on the two (A & B) pins.

DC Electrical Characteristics for 10/100 Base-T Ethernet Switching over Operating Range

($T_A = -40^{\circ}\text{C}$ to $+85^{\circ}\text{C}$, $V_{CC} = 3.3\text{V} \pm 10\%$)

Parameter	Description	Test Conditions ⁽¹⁾	Min.	Typ. ⁽²⁾	Max.	Units
V_{IH}	Input HIGH Voltage	Guaranteed HIGH level (Control Pins)	2.0			V
V_{IL}	Input LOW Voltage	Guaranteed LOW level (Control Pins)	-0.5		0.8	
V_{IK}	Clamp Diode Voltage	$V_{CC} = \text{Max.}, I_{IN} = -18\text{mA}$		-0.7	-1.2	
I_{IH}	Input HIGH Current	$V_{CC} = \text{Max.}, V_{IN} = V_{CC}$			± 5	μA
I_{IL}	Input LOW Current	$V_{CC} = \text{Max.}, V_{IN} = \text{GND}$			± 5	
R_{ON}	Switch On-Resistance ⁽³⁾	$V_{CC} = \text{Min.}, 1.25\text{V} \leq V_{IN} \leq V_{CC}$ $I_{IN} = -10\text{mA}$ to -30mA		4.0	6.5	Ω
$R_{FLAT(ON)}$	On-Resistance Flatness ⁽³⁾	$V_{CC} = \text{Min.}, V_{IN} @ 1.25\text{V}$ and V_{CC} $I_{IN} = -10\text{mA}$ to -30mA		0.5	-	
ΔR_{ON}	On-Resistance match from center ports to any other port ⁽³⁾	$V_{CC} = \text{Min.}, 1.25\text{V} \leq V_{IN} \leq V_{CC}$ $I_{IN} = -10\text{mA}$ to -30mA		0.4	1.0	

Notes:

1. For max. or min. conditions, use appropriate value specified under Electrical Characteristics for the applicable device type.
2. Typical values are at $V_{CC} = 3.3\text{V}$, $T_A = 25^{\circ}\text{C}$ ambient and maximum loading.
3. Measured by the voltage drop between A and B pins at indicated current through the switch. ON resistance is determined by the lower of the voltages on the two (A & B) pins.

Capacitance ($T_A = 25^\circ\text{C}$, $f = 1\text{MHz}$)

Parameters ⁽¹⁾	Description	Test Conditions	Typ.	Max.	Units
C_{IN}	Input Capacitance	$V_{IN} = 0\text{V}$	2.0	3.0	pF
$C_{OFF(B1, B2)}$	Port B Capacitance, Switch OFF		4.0	6.0	
$C_{ON(A/B)}$	A/B Capacitance, Switch ON		10.0	11.0	

Notes:

1. This parameter is determined by device characterization but is not production tested.

Power Supply Characteristics

Parameters	Description	Test Conditions ⁽¹⁾	Min.	Typ. ⁽²⁾	Max.	Units
I_{CC}	Quiescent Power Supply Current	$V_{CC} = \text{Max.}, V_{IN} = \text{GND or } V_{CC}$		0.5	3.5	mA

Notes:

1. For max. or min. conditions, use appropriate value specified under Electrical Characteristics for the applicable device type.
2. Typical values are at $V_{CC} = 3.3\text{V}$, $T_A = 25^\circ\text{C}$ ambient and maximum loading.

Dynamic Electrical Characteristics Over the Operating Range ($T_A = -40^\circ\text{C}$ to $+85^\circ\text{C}$, $V_{CC} = 3.3\text{V} \pm 10\%$, $\text{GND} = 0\text{V}$)

Parameter	Description	Test Conditions ⁽¹⁾	Min.	Typ. ⁽²⁾	Max.	Units
X_{TALK}	Crosstalk	$R_L = 100\Omega, f = 250\text{MHz}$		-27		dB
O_{IRR}	OFF Isolation			-32		
BW	Bandwidth -3dB	$R_L = 100\Omega$		350		MHz

Notes:

1. For max. or min. conditions, use appropriate value specified under Electrical Characteristics for the applicable device type.
2. Guaranteed by design.

Switching Characteristics

Parameter	Description	Min.	Typ. ⁽¹⁾	Max.	Units
t_{PD}	Propagation Delay ⁽²⁾		0.25		ns
t_{PZH}, t_{PZL}	Line Enable Time - SEL to A_N, B_N	0.5		15.0	
t_{PHZ}, t_{PLZ}	Line Disable Time - SEL to A_N, B_N	0.5		9.0	
$t_{SK(o)}$	Output Skew between center port (A_4 to A_5) to any other port		0.1	0.2	
$t_{SK(p)}$	Skew between opposite transitions of the same output ($t_{PHL} - t_{PLH}$)		0.1	0.2	

Notes:

1. Guaranteed by design.
2. The bus switch contributes no propagational delay other than the RC delay of the ON resistance of the switch and the load capacitance. The time constant for the switch alone is of the order of 0.25ns for 10pF load. Since this time constant is much smaller than the rise/fall times of typical driving signals, it adds very little propagational delay to the system. Propagational delay of the bus switch when used in a system is determined by the driving circuit on the driving side of the switch and its interactions with the load on the driven side.

Test Circuit for Electrical Characteristics

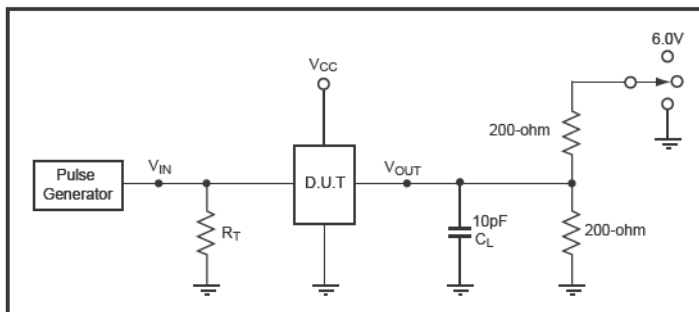

Notes:

- C_L = Load capacitance: includes jig and probe capacitance
- R_T = Termination resistance: should be equal to Z_{OUT} of the Pulse Generator

Switch Positions

Test	Switch
t_{PLZ} , t_{PZL} (output on B-side)	6.0V
t_{PHZ} , t_{PZH} (output on B-side)	GND
Prop Delay	Open

Test Circuit for Dynamic Electrical Characteristics

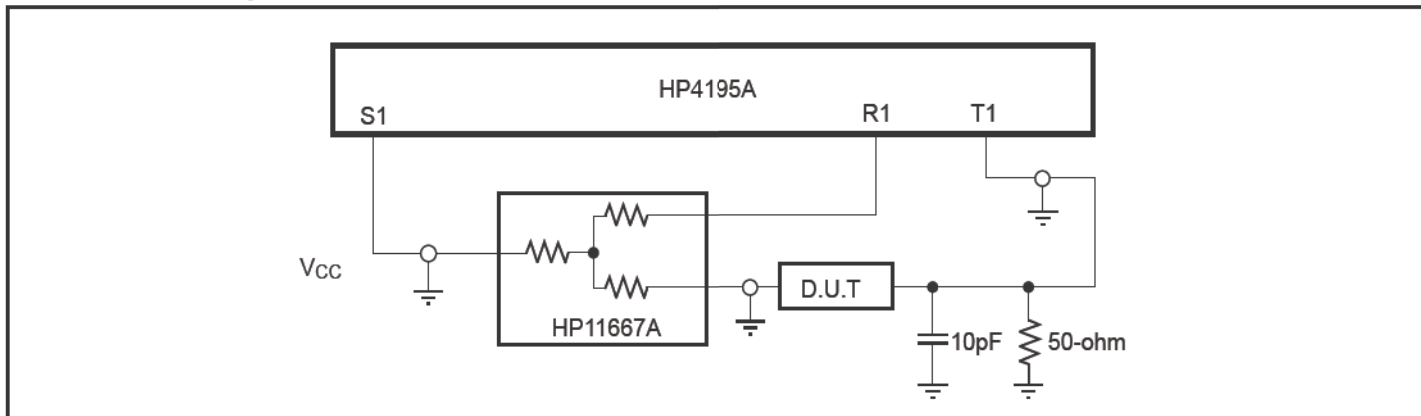

Switching Waveforms

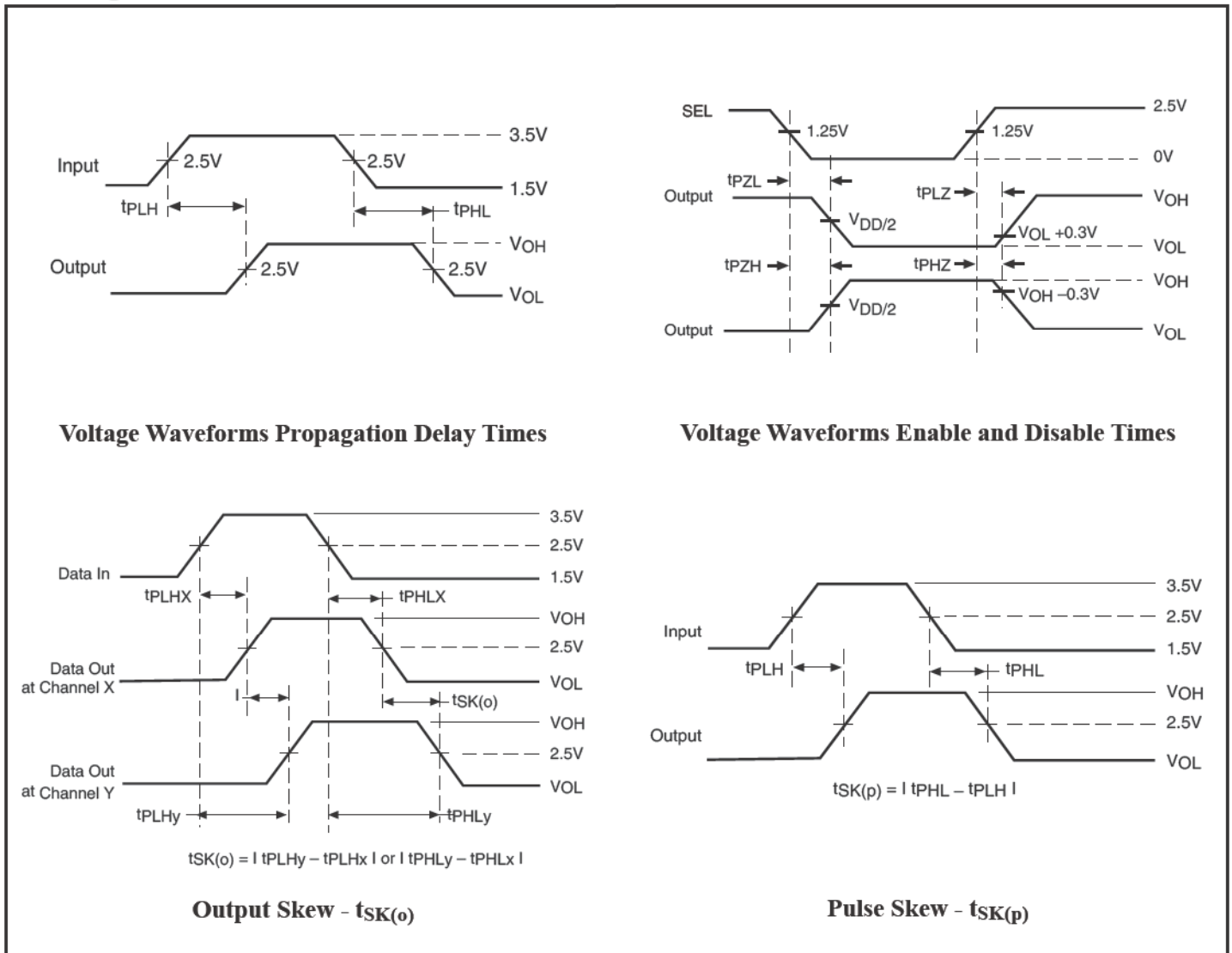

Notes:

- Waveform 1 is for an output with internal conditions such that the output is low except when disabled by the output control.
- Waveform 2 is for an output with internal conditions such that the output is high except when disabled by the output control.
- All input impulses are supplied by generators having the following characteristics: $PRR \leq 10 \text{ MHz}$, $Z_O = 50\Omega$, $t_R \leq 2.5\text{ns}$, $t_F \leq 2.5\text{ns}$.
- The outputs are measured one at a time with one transition per measurement.

Applications Information

Logic Inputs

The logic control inputs can be driven up to +3.6V regardless of the supply voltage. For example, given a +3.3V supply, the output enables or select pins may be driven low to 0V and high to 3.6V. Driving the control pin(s) Rail-to-Rail[®] minimizes power consumption.

Rail-to-Rail is a registered trademark of Nippon Motorola, Ltd.

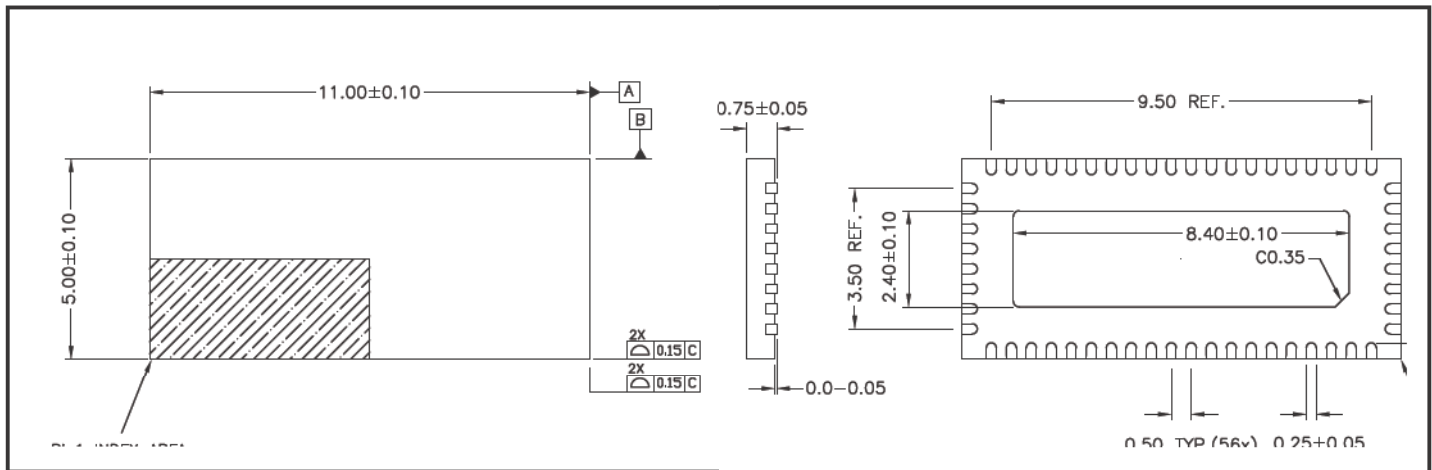
Packaging Mechanical: 56-Contact TQFN (ZF)

Ordering Information

Ordering Number	Package Code	Package Description
PI3L500ZF	ZF	56-contact TQFN
PI3L500ZFE	ZF	Pb-free & Green, 56-contact TQFN

Notes:

- Thermal characteristics can be found on the company web site at www.pericom.com/packaging/
- E = Pb-free & Green
- Adding an X suffix = Tape/Reel

Looking for pricing, stock, or lifecycle information?

Click below to explore more details on WIN SOURCE:

-  [View PI3L500ZFE on WIN SOURCE](#)
-  [Diodes Incorporated Information](#)

Optimize Your Supply Chain with WIN SOURCE Solutions

-  Global Sourcing Solution
-  Obsolete Management
-  Cost Control Management
-  Shortage Management
-  Alternative Solution
-  Excess Inventory Management