



**THE DATASHEET OF
PI6C2408-3WE**



3.3V 4+4 Output Zero-delay Clock Driver

Features

- Maximum rated frequency: 140 MHz
- Low cycle-to-cycle jitter
- Input to output delay, less than 150ps
- External feedback pin allows outputs to be synchronized to the clock input
- 5V tolerant CLKIN input
- Operates at 3.3V V_{DD}
- Test mode allows bypass of the PLL for system testing purposes (e.g., IBIS measurements)
- Clock frequency multipliers ½x to 4x dependent on option
- Packaging (Pb-free and Green available):
 - 16-pin, 150-mil SOIC (W)
 - 16-pin 173-mil TSSOP (L)

Description

The PI6C2408 is a PLL-based, zero-delay buffer, with the ability to distribute eight outputs of up to 140MHz at 3.3V. Two banks of four outputs exist, and, depending on product option ordered, can supply either reference frequency, prescaled half frequency, or multiplied 2x or 4x input clock frequencies. The PI6C2408 family has a power-sparing feature: when input SEL2 is 0, the component will 3-state one or both banks of outputs depending on the state of input SEL1. A PLL bypass test mode also exists. This product line is available in high-drive and industrial environment versions.

An external feedback pin is used to synchronize the outputs to the input; the relationship between loading of this signal and the other outputs determines the input-output delay.

The PI6C2408 is characterized for both commercial and industrial operation.

Block Diagram

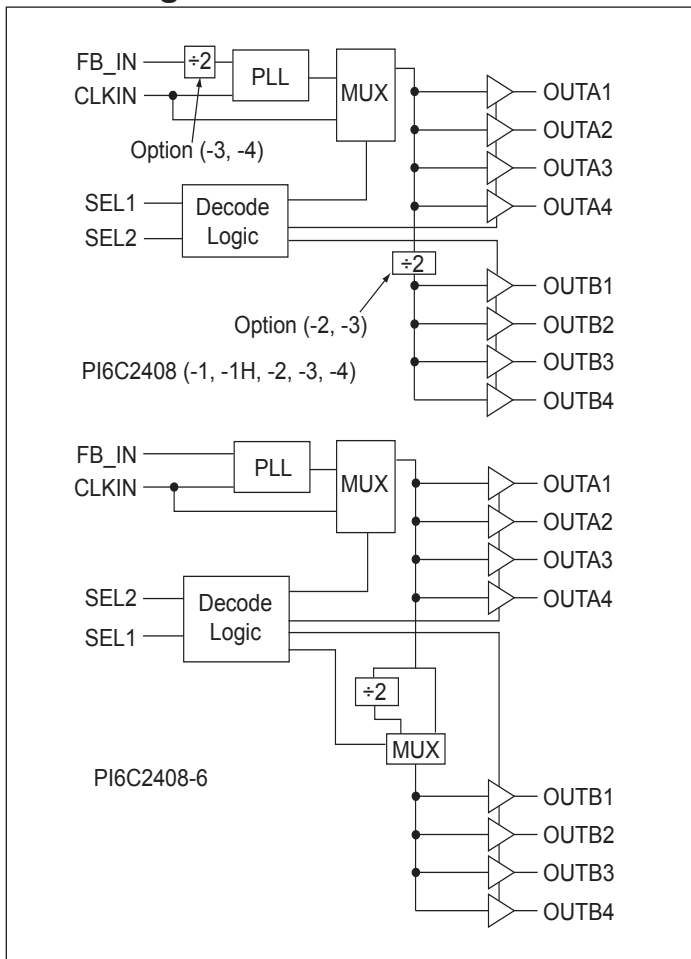

Pin Configuration

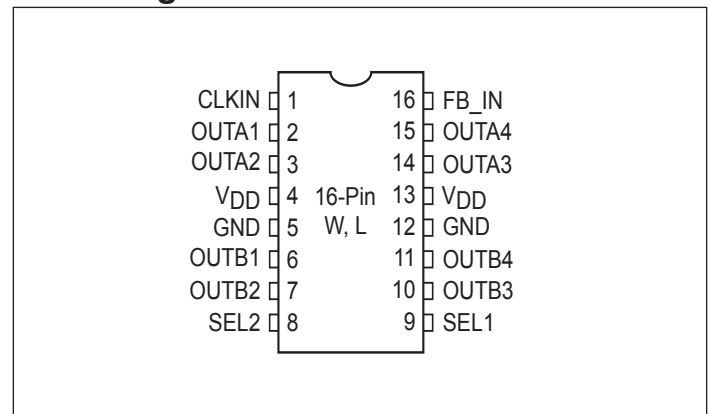

Input Select Decoding for PI6C2408 (-1, -1H,-4)

SEL2	SEL1	OUTA [1-4]	OUTB [1-4]	Output Source	PLL
0	0	3-State	3-State	PLL	OFF
0	1	PLL	3-State	PLL	ON
1	0	CLKIN	CLKIN	CLKIN	OFF
1	1	PLL	PLL	PLL	ON

Input Select Decoding for PI6C2408 (-2,-3)

SEL2	SEL1	OUTA [1-4]	OUTB [1-4]	Output Source	PLL
0	0	3-State	3-State	PLL	OFF
0	1	PLL	3-State	PLL	ON
1	0	CLKIN	CLKIN/2	CLKIN	OFF
1	1	PLL	PLL	PLL	ON

Input Select Decoding for PI6C2408-6

SEL2	SEL1	OUTA [1-4]	OUTB [1-4]	Output Source	PLL
0	0	3-State	3-State	PLL	OFF
0	1	CLKIN	CLKIN/2	CLKIN	OFF
1	0	PLL	PLL	PLL	ON
1	1	PLL	PLL/2	PLL	ON

PI6C2408 Configurations

Device	Feedback From	OUTA [1-4] Frequency	OUTB [1-4] Frequency
PI6C2408-1	OUTA or OUTB	CLKIN	CLKIN
PI6C2408-1H	OUTA or OUTB	CLKIN	CLKIN
PI6C2408-2	OUTA	CLKIN	CLKIN/2
PI6C2408-2	OUTB	2X CLKIN	CLKIN
PI6C2408-3	OUTA	2X CLKIN	CLKIN or $\overline{\text{CLKIN}}^{(1)}$
PI6C2408-3	OUTB	4X CLKIN	2X CLKIN
PI6C2408-4	OUTA or OUTB	2X CLKIN	2X CLKIN
PI6C2408-6	OUTA	CLKIN	CLKIN or CLKIN/2
PI6C2408-6	OUTB	CLKIN or 2X CLKIN	CLKIN

Note:

1. Output phase is indeterminant (0° or 180° from CLKIN)

Pin Description

Pin	Signal	Description
1	CLKIN	Input clock reference frequency (weak pull-down)
2, 3, 14, 15	OUTA[1-4]	Clock output, Bank A (weak pull-down)
4, 13	V _{DD}	3.3V supply
5, 12	GND	Ground
6, 7, 10, 11	OUTB[1-4]	Clock output, Bank B (weak pull-down)
8	SEL2	Select input, bit 2 (weak pull-up)
9	SEL1	Select input, bit 1 (weak pull-up)
16	FB_IN	PLL feedback input

Zero Delay and Skew Control

CLKIN Input to Output Bank Delay vs. Difference in Loading between FB_IN pin and OUTA/OUTB pins

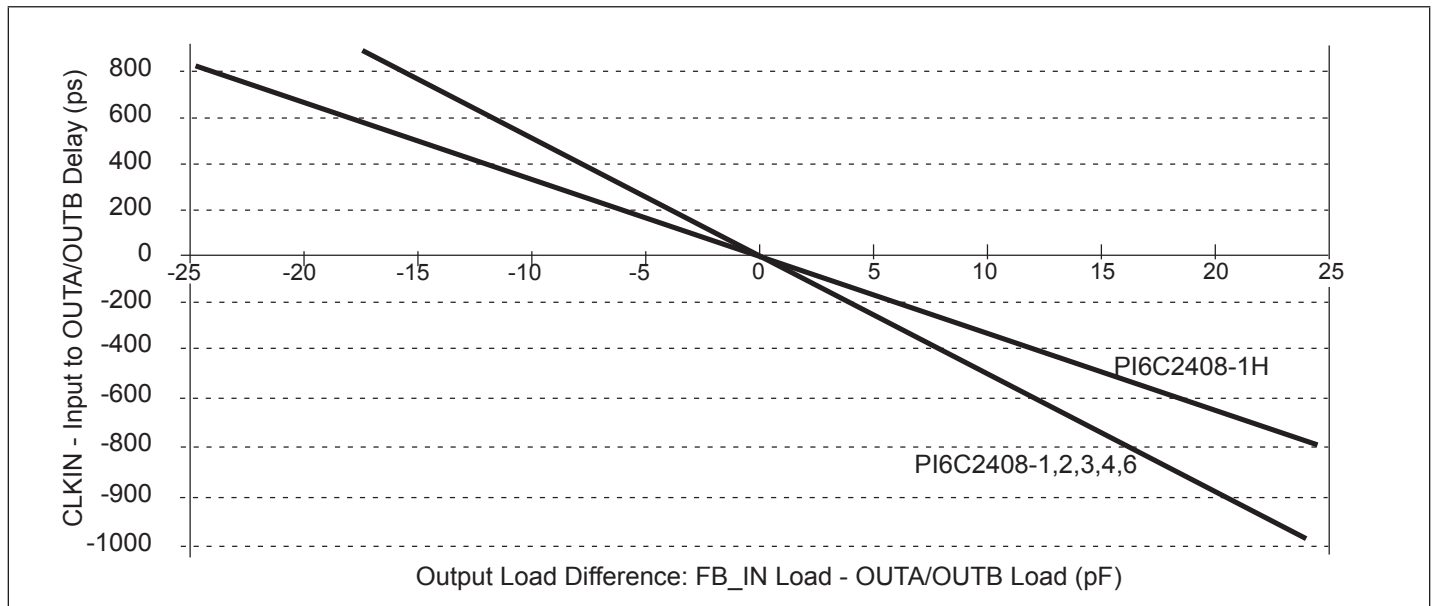

The relationship between loading of the FB_IN signal and other outputs determines the input-output delay. Zero delay is achieved when all outputs, including feedback, are loaded equally.

Maximum Ratings (Above which the useful life may be impaired. For user guidelines, not tested)

Supply Voltage to Ground Potential.....	-0.5V to +7.0V
DC Input Voltage (Except CLKIN).....	-0.5V to V _{DD} +0.5V
DC Input Voltage CLKIN.....	-0.5 to 7V
Storage Temperature.....	-65°C to +150°C
Maximum Soldering Temperature (10 seconds).....	260°C
Junction Temperature.....	150°C
Static Discharge Voltage*.....	>2000V

Note:

Stresses greater than those listed under MAXIMUM RATINGS may cause permanent damage to the device. This is a stress rating only and functional operation of the device at these or any other conditions above those indicated in the operational sections of this specification is not implied. Exposure to absolute maximum rating conditions for extended periods may affect reliability.

*per MIL-STD-883, Method 3015

Operating Conditions

Parameter	Description	Min.	Max.	Units	
V _{DD}	Supply Voltage	Commercial	3.0	3.6	V
		Industrial	3.135	3.465	
T _A	Commercial Operating Temperature	0	70	°C	
	Industrial Operating Temperature	-40	85		
C _L	Load Capacitance, below 100 MHz	¼	30	pF	
	Load Capacitance, from 100 MHz to 140MHz	¼	15		
C _{IN}	Input Capacitance	¼	7		

DC Electrical Characteristics for Industrial Temperature Devices

Parameter	Description	Test Conditions	Min.	Max.	Units
V _{IL}	Input LOW Voltage			0.8	V
V _{IH}	Input HIGH Voltage		2.0		
I _{IL}	Input LOW Current	V _{IN} = 0V		50.0	µA
I _{IH}	Input HIGH Current	V _{IN} = V _{DD}		100.0	
V _{OL}	Output LOW Voltage	I _{OL} = 8mA (-1, -2, -3,-4, -6); I _{OL} = 12mA (-1H)		0.4	V
V _{OH}	Output HIGH Voltage	I _{OH} = -8mA (-1, -2, -3,-4, -6); I _{OH} = -12mA (-1H)	2.4		
I _{DD} (PD mode)	Pwr Dwn Supply Current	SEL1 = 0 (-1, -2, -3, -4, -1H); SEL2 = 0 (-6)		25.0	µA
I _{DD}	Supply Current	Unloaded outputs 100 MHz, Select inputs at V _{DD} or GND		54.0	mA
		Unloaded outputs 66 MHz, CLKIN, except (-1H)		70.0 (-1H)	
		Unloaded outputs 33MHz, CLKIN, except (-1H)		39.0	
				20.0	

AC Electrical Characteristics for Industrial Temperature Devices

Parameters	Name	Test Conditions	Min.	Typ.	Max.	Units
F _O	Output Frequency	30pF load	10		100	MHz
		15pF load			140	
t _{DC}	Duty Cycle ⁽¹⁾ (-1, -2, -3, -4, -6)	Measured at V _{DD} /2, F _{OUT} <66.67MHz 30pF load	40	50	60	%
		Measured at V _{DD} /2, F _{OUT} <140 MHz 15pF load				
		Measured at V _{DD} /2, F _{OUT} <45 MHz 30pF load				
	Duty Cycle ⁽¹⁾ (-1H)	Measured at V _{DD} /2, F _{OUT} <66.67MHz 30pF load	45		55	
		Measured at V _{DD} /2, F _{OUT} <140 MHz 15pF load				
		Measured at V _{DD} /2, F _{OUT} <45MHz 30pF load				
t _R	Rise Time ⁽¹⁾ (-1, -2, -4, -6)	Measured between 0.8V and 2.0V, 30pF load			2.5	ns
		Measured between 0.8V and 2.0V, 15pF load			1.8	
	Rise Time ⁽¹⁾ (-1H)	Measured between 0.8V and 2.0V, 30pF load		1.6		
t _F	Fall Time ⁽¹⁾ (-1, -2, -4, -6)	Measured between 0.8V and 2.0V, 30pF load			2.2	ns
		Measured between 0.8V and 2.0V, 15pF load			1.5	
	Fall Time ⁽¹⁾ (-1H)	Measured between 0.8V and 2.0V, 30pF load		1.25		
t _{SK(O)}	Output to Output Skew(1) within same Bank	All outputs equally loaded			250	
	Output Bank A to Output Bank B Skew(1)		400			
t ₀	Delay, CLKIN Rising Edge to FB_IN Rising Edge ⁽¹⁾	Measured at V _{DD} /2			900	ps
t _{SK(D)}	Device-to-Device Skew ⁽¹⁾	Measured at V _{DD} /2 on FB_IN pins of devices		0	500	
t _{SLEW}	Output Slew Rate ⁽¹⁾	Measured between 0.8V & 2.0V on -1H device using Test Crt #2	1			V/ns
t _{JIT}	Cycle-to-Cycle Jitter ⁽¹⁾ (-1, -1H, -4)	Measured at 66.67 MHz, loaded 30pF load			250	ps
		Measured at 140 MHz, loaded 15pF load			150	
	Cycle-to-Cycle Jitter ⁽¹⁾ (-2, -6)	Measured at 66.67 MHz, loaded 30pF load			400	
t _{LOCK}	PLL Lock Time ⁽¹⁾	Stable power supply, valid clocks presented on CLKIN and FB_IN pins			1.0	ms

Notes:

1. See Switching Waveforms on page 7.

DC Electrical Characteristics for Commercial Temperature Devices

Parameter	Description	Test Conditions	Min.	Max.	Units
V _{IL}	Input LOW Voltage	$\frac{3}{4}$	$\frac{3}{4}$	0.8	V
V _{IH}	Input HIGH Voltage	$\frac{3}{4}$	2.0	$\frac{3}{4}$	
I _{IL}	Input LOW Current	V _{IN} = 0V	$\frac{3}{4}$	50	μ A
I _{IH}	Input HIGH Current	V _{IN} = V _{DD}	$\frac{3}{4}$	100	
V _{OL}	Output LOW Voltage	I _{OL} = 8mA (-1, -2, -3,-4, -6); I _{OL} = 12mA (-1H)	$\frac{3}{4}$	0.4	V
V _{OH}	Output HIGH Voltage	I _{OH} = -8mA (-1, -2, -3,-4, -6); I _{OH} = -12mA (-1H)	2.4	$\frac{3}{4}$	
I _{DD} (PD mode)	Power Down Supply Current	SEL1 = 0 (-1,-2,-3,-4,-1H); SEL2 = 0 (-6)	$\frac{3}{4}$	12	μ A
I _{DD}	Supply Current	Unloaded outputs, 66.67 MHz, Select inputs at V _{DD} or GND	$\frac{3}{4}$	39	mA
I _{DD}	Supply Current	Unloaded outputs 100 MHz Select Inputs @ V _{DD} or GND	$\frac{3}{4}$	54	

AC Electrical Characteristics for Commercial Temperature Device

Parameter	Name	Test Conditions	Min.	Typ.	Max.	Units
F _O	Output Frequency	30pF load	10		100	MHz
		15pF load			140	
t _{DC}	Duty Cycle ⁽¹⁾ (-1H)	Measured at V _{DD} /2, for high drive output	45	50	55	%
	Duty Cycle (-1, -2, -3, -4, -6)	Measured at V _{DD} /2, for normal drive output	40	50	60	
t _R	Rise Time ⁽¹⁾ @30pF	Measured between 0.8V and 2.0V			2.5	ns
	Rise Time ⁽¹⁾ @15pF	Measured between 0.8V and 2.0V			1.8	
	Rise Time ⁽¹⁾ @30pF (-1H)	Measured between 0.8V and 2.0V			1.5	
t _F	Fall Time ⁽¹⁾ @30pF	Measured between 0.8V and 2.0V			2.2	
	Fall Time ⁽¹⁾ @15pF	Measured between 0.8V and 2.0V			1.5	
	Fall Time ⁽¹⁾ @30pF (-1H)	Measured between 0.8V and 2.0V			1.25	
t _{SK(O)}	Output-to-Output Skew ⁽¹⁾ within same bank	All outputs equally loaded, V _{DD} /2			250	ps
	Output Bank A to Output Bank B Skew	All outputs equally loaded, V _{DD} /2			400	
t _o	Input-to-Output Delay, CLKIN Rising Edge to FB_IN Rising Edge ⁽¹⁾	Measured at V _{DD} /2			900	
t _{SK(D)}	Device to Device Skew ⁽¹⁾	Measured at V _{DD} /2 on FB_IN pins of devices		0	500	
t _{SLEW}	Output Slew Rate ⁽¹⁾	Measured between 0.8V and 2.0V on -1H device using Test Circuit #2	1			V/ns
t _{JIT}	Cycle-to-Cycle Jitter ⁽¹⁾ (-1,-1H,-4)	Measured at 66.67 MHz, loaded 30pF output			250	ps
		Measured at 140 MHz, loaded 15pF output			150	
	Cycle-to-Cycle Jitter ⁽¹⁾ (-2,-3,-6)	Measured at 66.7 MHz, loaded 30pF output			400	
t _{LOCK}	PLL Lock Time ⁽¹⁾	Stable power supply, valid clocks presented on CLKIN and FB_IN pins			1.0	ms

Notes:

1. See Switching Waveforms on page 7.

Switching Waveforms

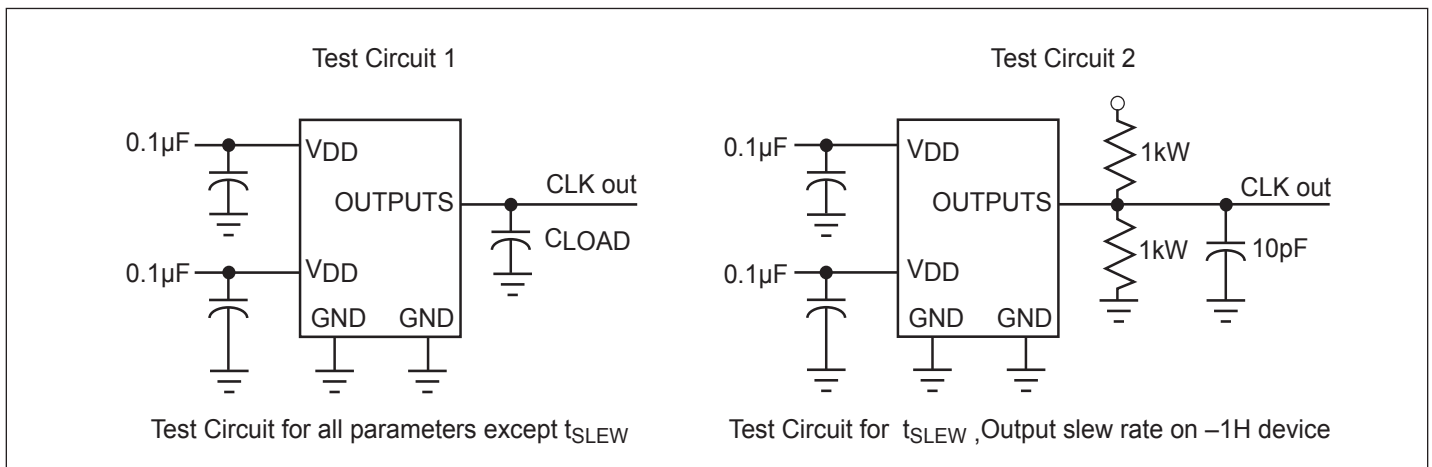
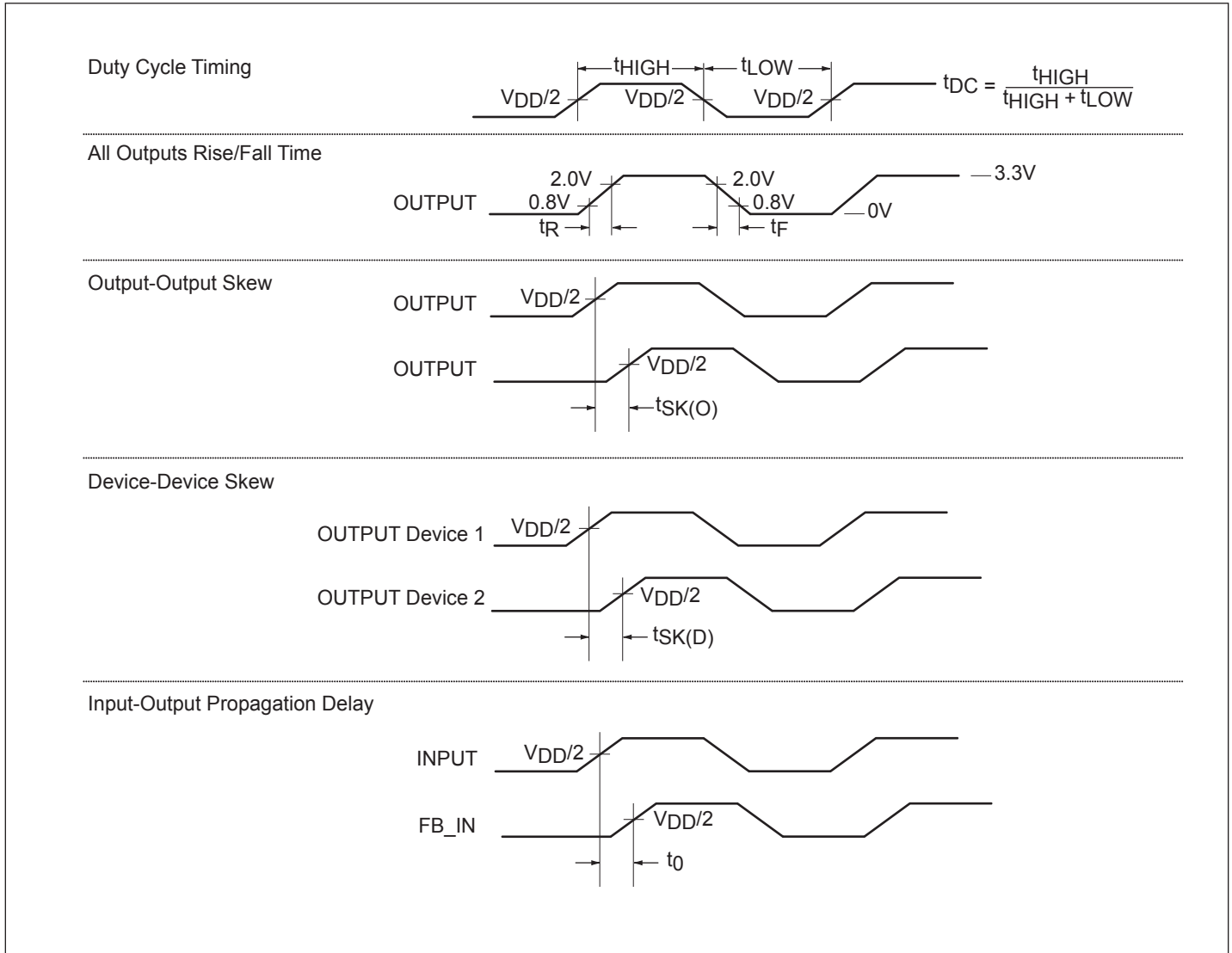

Packaging: 16-Pin SOIC (W)

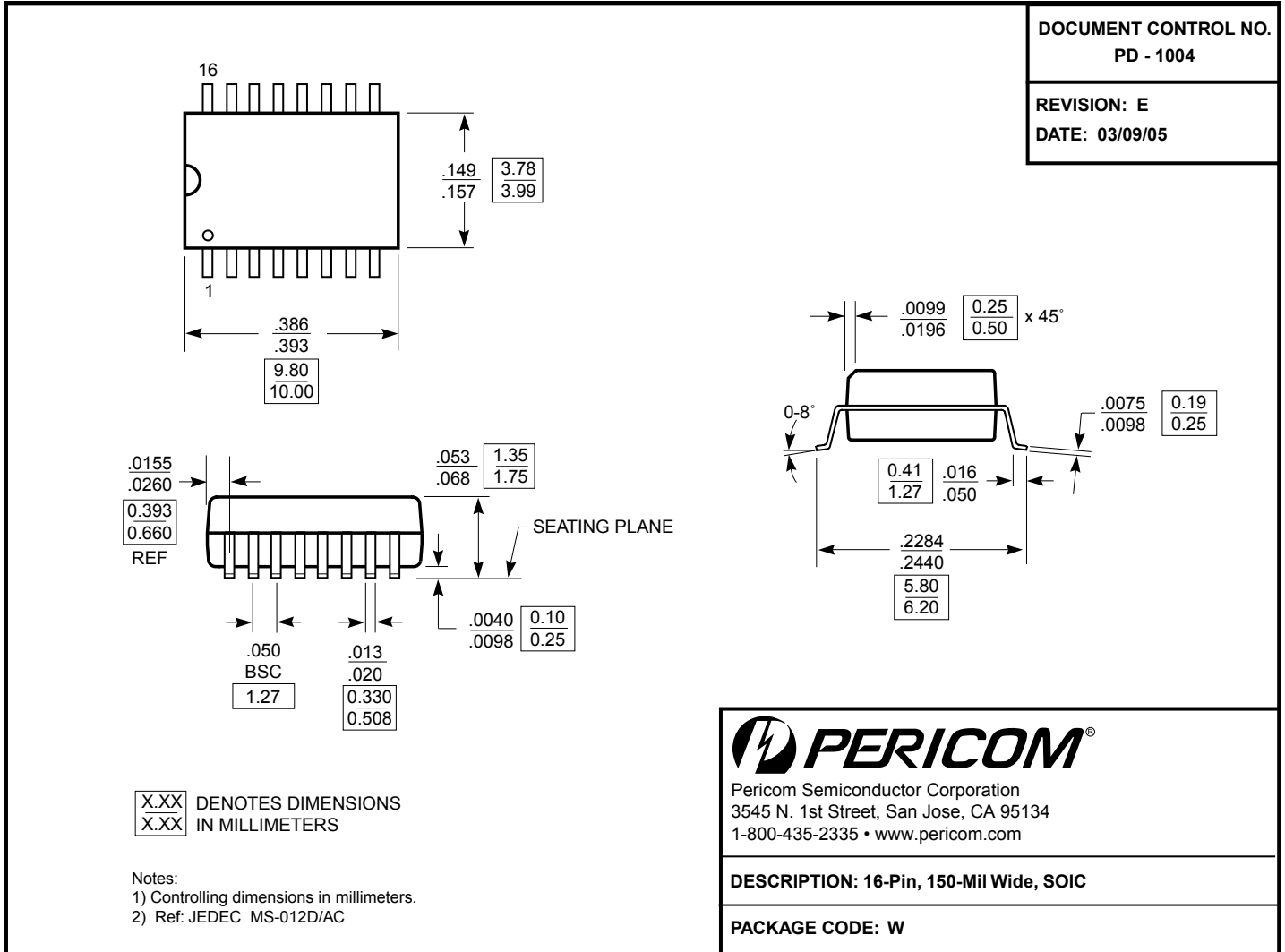

Note: For latest package info, please check: <http://www.pericom.com/products/packaging/mechanicals.php>

Packaging: 16-Pin TSSOP (L)

DOCUMENT CONTROL NO.
PD - 1310

REVISION: E
DATE: 03/09/05

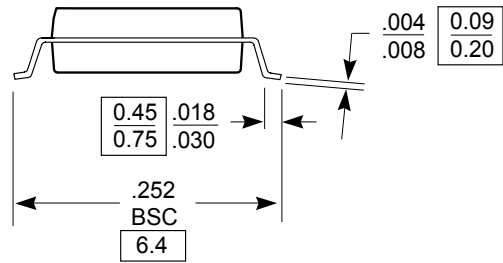
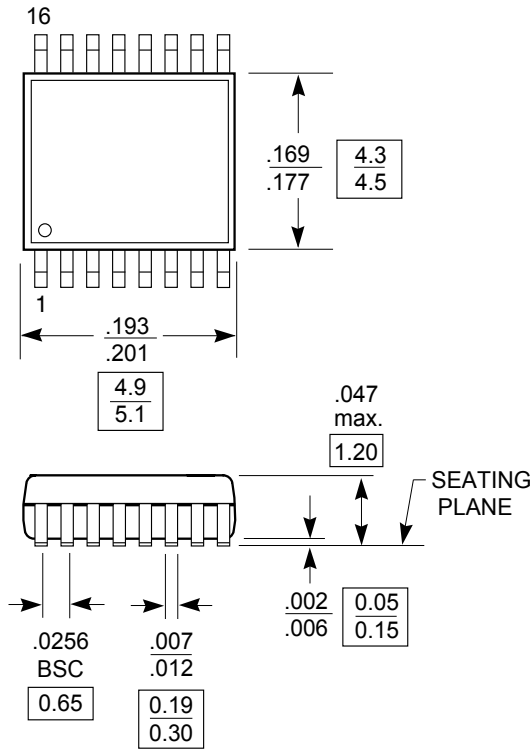

- Note:**
1. Package Outline Exclusive of Mold Flash and Metal Burr
 2. Controlling dimentions in millimeters
 3. Ref: JEDEC MO-153F/AB



Pericom Semiconductor Corporation
3545 N. 1st Street, San Jose, CA 95134
1-800-435-2335 • www.pericom.com

DESCRIPTION: 16-Pin, 173-Mil Wide, TSSOP

PACKAGE CODE: L

Note: For latest package info, please check: <http://www.pericom.com/products/packaging/mechanicals.php>

Ordering Information**Commercial Temperature Device**

Ordering Code	Package Code	Description	Operating Range
PI6C2408-3WE	W	Pb-free & Green, 16-pin 150-mil SOIC	Commercial
PI6C2408-1LE	L	Pb-free & Green, 16-pin 173-mil TSSOP	Commercial
PI6C2408-1HLE	L	Pb-free & Green, 16-pin 173-mil TSSOP	Commercial
PI6C2408-4LE	L	Pb-free & Green, 16-pin 173-mil TSSOP	Commercial
PI6C2408-1LE	L	Pb-free & Green 16-pin 173-mil TSSOP	Commercial
PI6C2408-1HLE	L	Pb-free & Green 16-pin 173-mil TSSOP	Commercial
PI6C2408-1HLEX	L	Pb-free & Green, 16-pin 173-mil TSSOP	Commercial

- Thermal characteristics can be found on the company web site at www.pericom.com/packaging/
- E = Pb-free and Green
- Adding an X suffix = Tape/Reel

Industrial Temperature Device

Ordering Code	Package	Description	Operating Range
PI6C2408-3WIE	W	Pb-free & Green, 16-pin 150-mil SOIC	Industrial
PI6C2408-1LIE	L	Pb-free & Green, 16-pin 173-mil TSSOP	Industrial

- Thermal characteristics can be found on the company web site at www.pericom.com/packaging/
- E = Pb-free and Green
- Adding an X suffix = Tape/Reel

Looking for pricing, stock, or lifecycle information?

Click below to explore more details on WIN SOURCE:

 [View PI6C2408-3WE on WIN SOURCE](#)

 [Diodes Incorporated Information](#)

Optimize Your Supply Chain with WIN SOURCE Solutions

-  Global Sourcing Solution
-  Obsolete Management
-  Cost Control Management
-  Shortage Management
-  Alternative Solution
-  Excess Inventory Management