

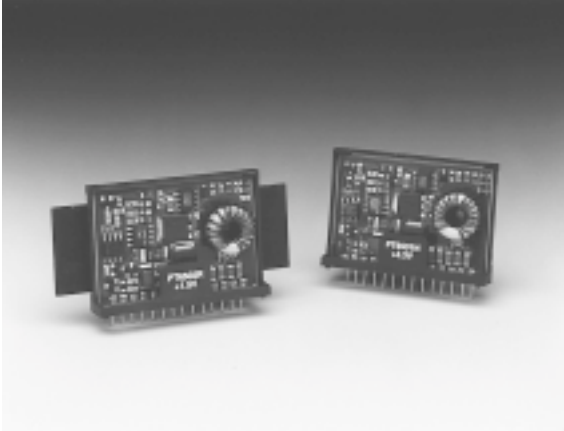

**THE DATASHEET OF
PT6523B**





Description

These power modules are a series of high performance, 8-A rated, Integrated Switching Regulators (ISRs), housed in a low cost 14-Pin SIP (Single In-line Package). Operating from either a 3.3V or 5V standard power bus, the PT6520 series produces a high-output, low-voltage power source for the industry's latest high-speed, microprocessors, ASICs, & DSPs. This allows for the easy integration of these new low-voltage ICs into existing 3.3V or 5V systems without re-designing the power supply.

The PT6520 series features an output On/Off standby pin and output short-circuit protection.

Features

- 8A Rated Output Current
- Single Device: 3.3V/5V Input
- High Efficiency (92% for PT6521)
- Small Footprint (0.75 in², Suffix 'P')
- Output On/Off Standby Control
- Output Short-Circuit Protection
- Adjustable Output Voltage
- Soft Startup
- 16-pin Mount Option (Suffixes L, M, Q, & F)

Ordering Information

- † PT6521□ = 3.3 Volts
- † PT6522□ = 1.5 Volts
- † PT6523□ = 2.5 Volts
- † PT6525□ = 2.1 Volts
- † PT6526□ = 1.8 Volts
- † PT6527□ = 1.2 Volts

† 3.3V Input Bus Capable

Note:
Back surface of product is electrically conductive

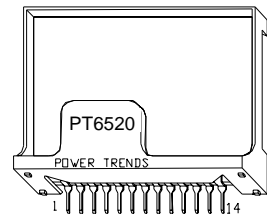

PT Series Suffix (PT1234x)

Case/Pin Configuration	Order Suffix	Package Code *
Vertical	P	(EED)
Horizontal	D	(EEA)
SMD	E	(EEC)
Horizontal, 2-Pin Tab	M	(EEM)
SMD, 2-Pin Tab	L	(EEL)
Horizontal, 2-Pin Ext Tab	Q	(EEQ)
SMD, 2-Pin Ext Tab	F	(EEF)
Vertical, Side Tab	R	(EEE)
Horizontal, Side Tab	G	(EEG)
SMD, Side Tab	B	(EEK)

* Previously known as package styles 400/410.

(Reference the applicable package code drawing for the dimensions and PC board layout)

Pin-Out Information

Pin	Function
1	Remote Sense
2	Do Not Connect
3	STBY*
4	V _{in}
5	V _{in}
6	V _{in}
7	GND
8	GND
9	GND
10	GND
11	V _{out}
12	V _{out}
13	V _{out}
14	V _{out} Adjust

* For further information, see application notes.

Standard Application

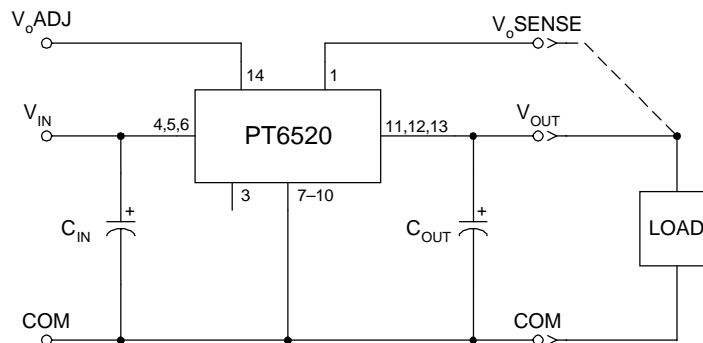

PT6520 Series

8-A 5-V/3.3-V Input Adjustable ISR with Short-Circuit protection

Specifications (Unless otherwise stated, $T_a = 25^\circ\text{C}$, $V_{in} = 5\text{V}$, $C_{in} = 330\mu\text{F}$, $C_{out} = 330\mu\text{F}$, and $I_o = I_{o,max}$)

Characteristic	Symbol	Conditions	PT6520 SERIES			Units	
			Min	Typ	Max		
Output Current	I_o	Over V_{in} range	0.1 ⁽¹⁾	—	8.0	A	
Input Voltage Range	V_{in}	Over I_o Range	$V_o = 3.3\text{V}$ 3.1 $V_o \leq 2.5\text{V}$	—	5.5 5.5	VDC	
Set Point Voltage Tolerance	$V_o \text{ tol}$		—	± 1	± 1.5	% V_o	
Temperature Variation	Reg_{temp}	$-40^\circ \leq T_a \leq +85^\circ\text{C}$, $I_o = I_{o,min}$	—	± 0.5	—	% V_o	
Line Regulation	Reg_{line}	Over V_{in} range	—	± 5	± 10	mV	
Load Regulation	Reg_{load}	Over I_o range	—	± 5	± 10	mV	
Total Output Voltage Variation	$\Delta V_{o,tot}$	Includes set-point, line, load, $-40^\circ \leq T_a \leq +85^\circ\text{C}$	—	± 2	± 3	% V_o	
Efficiency	η	$I_o = 3.0\text{A}$	$V_o = 3.3\text{V}$	—	92	—	%
			$V_o = 2.5\text{V}$	—	88	—	
			$V_o = 2.1\text{V}$	—	85	—	
			$V_o = 1.8\text{V}$	—	82	—	
			$V_o = 1.5\text{V}$	—	80	—	
			$V_o = 1.2\text{V}$	—	75	—	
		$I_o = 8.0\text{A}$	$V_o = 3.3\text{V}$	—	89	—	%
			$V_o = 2.5\text{V}$	—	85	—	
			$V_o = 2.1\text{V}$	—	82	—	
			$V_o = 1.8\text{V}$	—	78	—	
			$V_o = 1.5\text{V}$	—	75	—	
			$V_o = 1.2\text{V}$	—	71	—	
V_o Ripple (pk-pk)	V_r	20MHz bandwidth	—	35	—	mV _{pp}	
Transient Response	t_{tr}	1A/ μs load step, 50% to 100% $I_{o,max}$	—	50	—	μs	
	ΔV_{tr}	V_o over/undershoot	—	± 70	—	mV	
Short Circuit Threshold	I_{sc} threshold		—	12	22.5	A	
Switching Frequency	f_s	Over V_{in} and I_o range	300	350	400	kHz	
Remote On/Off (Pin 1)		Referenced to $-V_{in}$ (pin 7)					
Input High Voltage	V_{IH}		—	—	Open ⁽²⁾	V	
Input Low Voltage	V_{IL}		-0.1	—	+0.4		
Input Low Current	I_{IL}		—	-0.5	—	mA	
Standby Input Current	$I_{in, standby}$	pins 3 & 7 connected	—	15	25	mA	
External Output Capacitance	C_{out}	See application schematic	330	—	5,000	μF	
External Input Capacitance	C_{in}	See application schematic	330	—	—	μF	
Operating Temperature Range	T_a	Over V_{in} range	-40	—	+85 ⁽³⁾	$^\circ\text{C}$	
Storage Temperature	T_s	—	-40	—	+125	$^\circ\text{C}$	
Reliability	MTBF	Per Bellcore TR-332 50% stress, $T_a = 40^\circ\text{C}$, ground benign	6.3	—	—	10^6 Hrs	
Mechanical Shock	—	Per Mil-Std-883D, method 2002.3, 1ms, half-sine, mounted to a fixture	—	500	—	G's	
Mechanical Vibration Mil-Std-883D, 20-2000Hz	—	Suffixes P, D, & E Suffixes L & M	—	7.5	—	G's	
			—	TBD ⁽⁴⁾	—		
Weight	—	Suffixes P, D, & E Suffixes R, G & B Suffixes L & M Suffixes Q & F	—	12.5	—	grams	
			—	16.5	—		
			—	15.25	—		
			—	22	—		
Flammability	—	Materials meet UL 94V-0					

Notes: (1) The ISR will operate at no load with reduced specifications.

(2) The STBY* control (pin 3) has an internal pull-up and if it is left open circuit the module will operate when input power is applied. The open-circuit voltage is typically 12.6V, and maybe as high as 15V. Refer to the application notes for other interface considerations.

(3) See Safe Operating Area curves or contact the factory for the appropriate derating.

(4) The tab pins on the 16-pin mount package types (suffixes L & M) must be soldered. For more information see the applicable package outline drawing.

Input/Output Capacitors: The PT6520 series requires a 330 μF capacitor at both the input and output for proper operation in all applications. In addition, the input capacitance (C_{in}) must be rated for a minimum of 1.2Arms ripple current rating. For transient or dynamic load applications, additional output capacitance (C_{out}) may be necessary. The maximum allowable output capacitance is 5,000 μF . For more information consult the related application note on capacitor recommendations.

8-A 5-V/3.3-V Input Adjustable ISR with Short-Circuit protection

Characteristic Data; $V_{in} = 5.0V$ (See Note A)

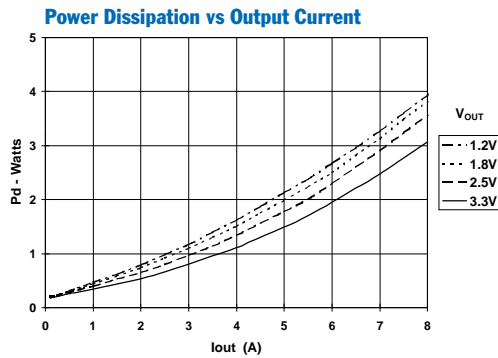
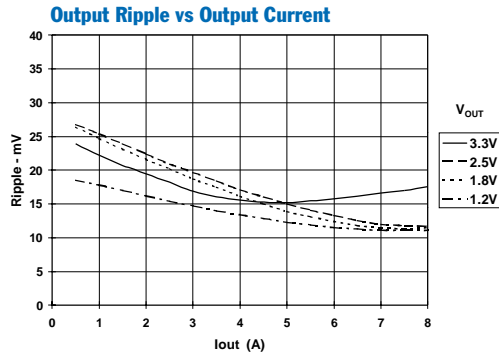
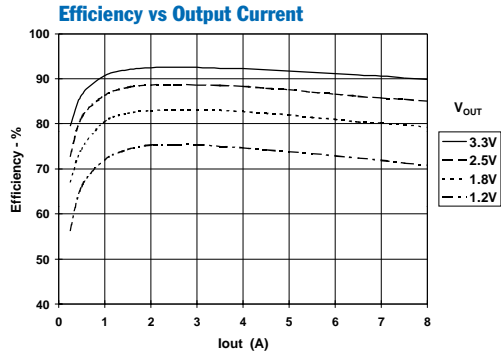

Safe Operating Area; $V_{in} = 5V$ (See Note B)

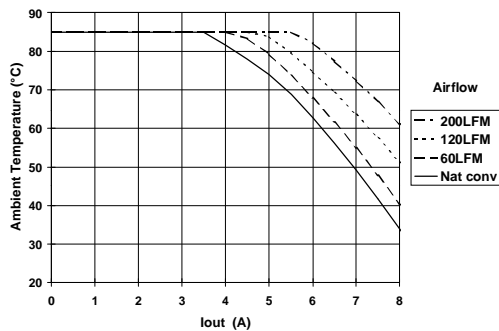

Characteristic Data; $V_{in} = 3.3V$ (See Note A)

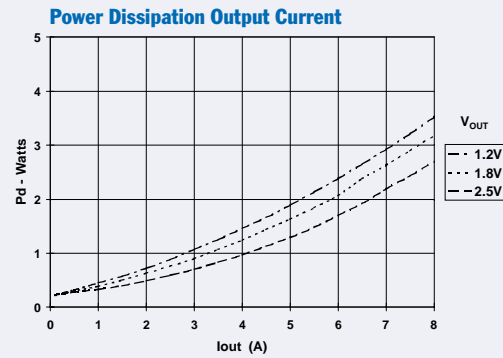
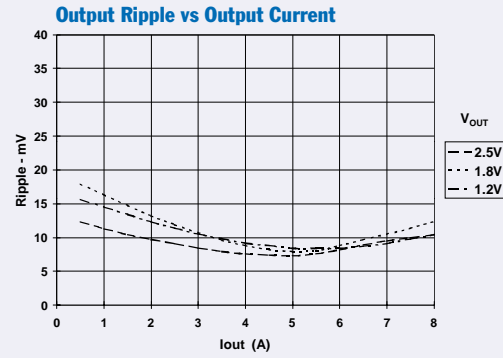
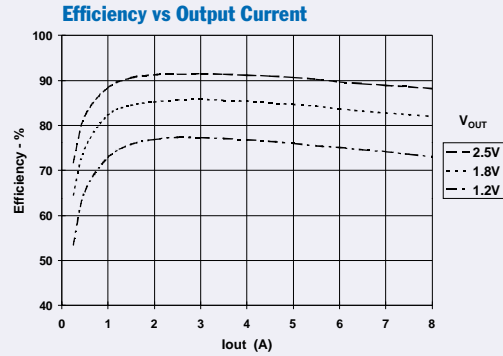

Safe Operating Area; $3.3V$ (See Note B)

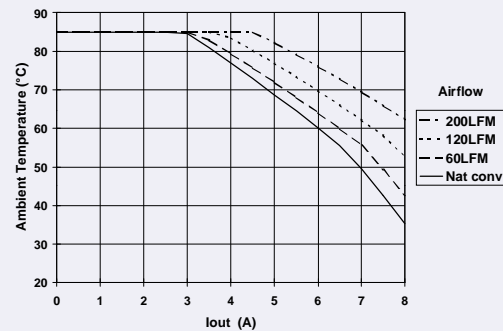

Note A: Characteristic data has been developed from actual products tested at 25°C. This data is considered typical data for the Converter.
 Note B: SOA curves represent the conditions at which internal components are at or below the manufacturer's maximum operating temperatures

Using the Standby Function of the PT6520 Series of Integrated Switching Regulators

The PT6520 series of power modules are high efficiency regulators that operate off either a 3.3V or 5V input bus voltage. These regulators incorporate a *Standby* function, which may be used in applications that require power-up/shutdown sequencing, and wherever there is a requirement for the output status of the module to be controlled by external circuitry.

The standby function is provided by the *STBY** control, pin 3. If pin 3 is left open-circuit¹ the regulator operates normally, and provides a regulated output when a valid supply voltage is applied to V_{in} (pins 4–6) with respect to GND (pins 7–10). If a low voltage² is then applied to pin 3 the regulator output will be disabled and the input current drawn by the ISR will be reduced to about 15mA³. The standby control may also be used to hold-off the regulator output during the period that input power is applied.

Pin 3 is ideally controlled with an open-collector (or open-drain) discrete transistor (See Figure 1). The open-circuit voltage is typically 12.6V. Table 1 gives the circuit parameters for this control input.

Table 1 Standby Control Requirements^(2, 3)

Parameter	Min	Typ	Max
Input Low (V_{IL})	-0.1V		+0.4V
I_{stby} (pin 3 =ground)		-0.5mA	
V_{stby} (open circuit)		12.6V	15V

Notes:

- 1 The standby control input requires no external pull-up resistor. The open-circuit voltage of the *STBY** pin is typically 12.6V.
- 2 The standby control input is Not compatible with TTL or other devices that incorporate a totem-pole output drive. Use only a true open-collector device, preferably a discrete bipolar transistor (or MOSFET). To ensure the regulator output is disabled, the control pin must be pulled to less than 0.4Vdc with a low-level 0.5mA sink to ground.
- 3 When the regulator output is disabled the current drawn from the input source is typically reduced to 15mA.

Figure 1

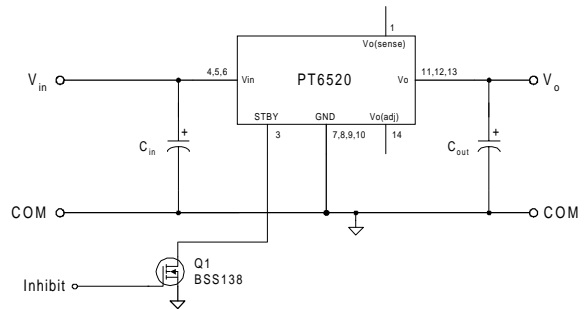

Turn-On Time: In the circuit of Figure 1, turning Q_1 on applies a low voltage to the *STBY* control (pin 3) and disables the regulator output. Correspondingly, turning Q_1 off removes the low-voltage signal and enables the output. Once enabled, the output will typically experience a 10–15ms delay followed by a predictable ramp-up of voltage. The regulator should provide a fully regulated output voltage within 40ms. The waveform of Figure 2 shows the output voltage and input current waveforms of a PT6521 (3.3V) following the turn-off of Q_1 . The turn off of Q_1 corresponds to the rise in V_{stby} . The waveforms were measured with a 5Vdc input voltage, and 4.5A resistive load.

Figure 2

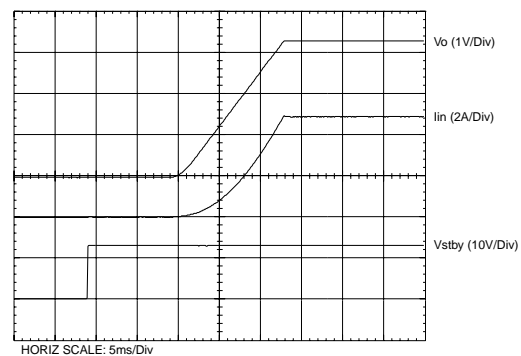

Adjusting the Output Voltage of the PT6520 Series of Integrated Switching Regulators

The output voltage of the PT6520 series of integrated switching regulators (ISRs) may be adjusted higher or lower than the factory trimmed pre-set voltage with the addition of a single external resistor. ¹ Table 1 gives the allowable adjustment range for each model in the series as V_a (min) and V_a (max).

Adjust Up: An increase in the output voltage is obtained by adding a resistor R_2 , between pin 14 (V_o adjust) and pins 7-10 (GND).

Adjust Down: Add a resistor (R_1), between pin 14 (V_o adjust) and pin 1 (V_o (sense)) ³.

Refer to Figure 1 and Table 2 for both the placement and value of the required resistor, either (R_1) or R_2 as appropriate.

The values of (R_1) [adjust down], and R_2 [adjust up], can also be calculated using the following formulas.

$$(R_1) = \frac{R_o (V_a - V_r)}{V_o - V_a} - R_s \quad \text{k}\Omega$$

$$R_2 = \frac{R_o \cdot V_r}{V_a - V_o} - R_s \quad \text{k}\Omega$$

Where: V_o = Original output voltage
 V_a = Adjusted output voltage
 V_r = The reference voltage (Table 1)
 R_o = The multiplier resistance (Table 1)
 R_s = The internal series resistance (Table 1)

Table 1

ADJUSTMENT AND FORMULA PARAMETERS						
Series Pt #	PT6527	PT6522	PT6526	PT6525	PT6523	PT6521
V_o (nom)	1.2	1.5	1.8	2.1	2.5	3.3
V_a (min)	1.09	1.47	1.75	1.95	2.25	2.75
V_a (max)	1.52	1.73	2.05	2.45	2.85	3.75
V_r (V)	0.8	1.27	1.27	1.27	1.27	1.27
R_o (k Ω)	10.0	10.2	10.0	10.0	10.0	10.0
R_s (k Ω)	24.9	49.9	49.9	33.2	33.2	24.9

Figure 1

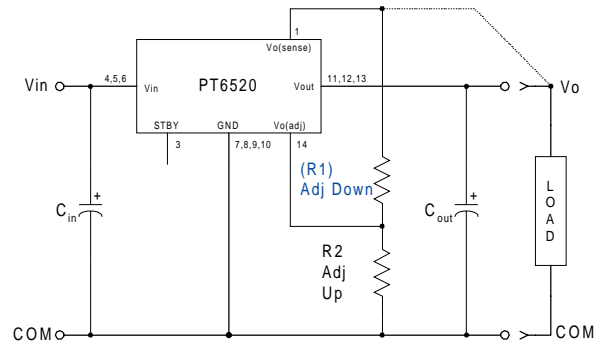

Notes:

1. Use only a single 1% resistor in either the (R_1) or R_2 location. Place the resistor as close to the ISR as possible.
2. Never connect capacitors from V_o adjust to either GND, V_{out} , or the Remote Sense pin. Capacitance added to the V_o adjust pin will affect the stability of the ISR.
3. If the Remote Sense feature is not being used, the resistor (R_1) may be connected between pin 14 (V_o adjust) and pins 11–13 (V_{out}).
4. Adjusting the output voltage of the PT6523 (2.5V model) higher than the factory pre-trimmed output voltage may increase the minimum input voltage specified for the part. This model must comply with the following requirements.

PT6523:

$V_{in}(\text{min}) = (V_a + 0.5)V$ or 3.1V, whichever is greater.

PT6520 Series

Table 2

PT6520 ADJUSTMENT RESISTOR VALUES

Series Pt #	PT6527	PT6522	PT6526	PT6525	PT6523	Series Pt #	PT6521
V_o (nom)	1.2V	1.5V	1.8V	2.1V	2.5V	V_o (nom)	3.3V
V_a (req'd)						V_a (req'd)	
1.1	(5.1)kΩ					2.75	(2.0)kΩ
1.15	(45.1)kΩ					2.8	(5.7)kΩ
1.2						2.85	(10.2)kΩ
1.25	135.0kΩ					2.9	(15.9)kΩ
1.3	55.1kΩ					2.95	(23.1)kΩ
1.35	28.4kΩ					3.0	(32.8)kΩ
1.4	15.1kΩ					3.05	(46.3)kΩ
1.45	7.1kΩ					3.1	(66.6)kΩ
1.47	4.7kΩ	(18.1)kΩ				3.15	(100.0)kΩ
1.5	1.8kΩ					3.2	(168.0)kΩ
1.55		209.0kΩ				3.25	(371.0)kΩ
1.6		79.6kΩ				3.3	
1.65		36.5kΩ				3.35	229.0kΩ
1.7		14.9kΩ				3.4	102.0kΩ
1.75			(46.1)kΩ			3.45	59.8kΩ
1.8						3.5	38.6kΩ
1.85			204.0kΩ			3.55	25.9kΩ
1.9			77.1kΩ			3.6	17.4kΩ
1.95			34.8kΩ	(12.1)kΩ		3.65	11.4kΩ
2.0			13.6kΩ	(39.8)kΩ		3.7	6.9kΩ
2.05				(123.0)kΩ		3.75	3.3kΩ
2.1							
2.15				221.kΩ			
2.2				93.8kΩ			
2.25				51.5kΩ	(6.0)kΩ		
2.3				30.3kΩ	(18.3)kΩ		
2.35				17.6kΩ	(38.8)kΩ		
2.4				9.1kΩ	(79.8)kΩ		
2.45				3.1kΩ	(203.0)kΩ		
2.5							
2.55					221.0kΩ		
2.6					93.8kΩ		
2.65				(See Note 4)	51.5kΩ		
2.7					30.3kΩ		
2.75					17.6kΩ		
2.8					9.1kΩ		
2.85					3.1kΩ		

R1 = (Blue) R2 = Black

Capacitor Recommendations for the PT6520 Series of Integrated Switching Regulators

Input Capacitors:

The recommended input capacitance is determined by 1.0 ampere minimum ripple current rating and 330µF minimum capacitance (300µF for Oscon® or low ESR tantalum). Ripple current and <100mΩ equivalent series resistance (ESR) values are the major considerations, along with temperature, when designing with different types of capacitors. Tantalum capacitors have a recommended minimum voltage rating of 2× the maximum DC voltage + AC ripple. This is necessary to insure reliability for input voltage bus applications

Output Capacitors:

The ESR of the required capacitor (C_{out}) must not be greater than 150mΩ. Electrolytic capacitors have poor ripple performance at frequencies greater than 400kHz but excellent low frequency transient response. Above the ripple frequency, ceramic capacitors are necessary to improve the transient response and reduce any high frequency noise components apparent during higher current excursions. Preferred low ESR type capacitor part numbers are identified in Table 1.

Tantalum Capacitors

Tantalum type capacitors may be used for the output but only the AVX TPS series, Sprague 593D/594/595 series or Kemet T495/T510 series. These capacitors are recommended over many other tantalum types due to their higher rated surge, power dissipation, and ripple current capability. As a caution the TAJ series by AVX is not recommended. This series has considerably higher ESR, reduced power dissipation, and lower ripple current capability. The TAJ series is less reliable than the AVX TPS series when determining power dissipation capability. Tantalum or Oscon® types are recommended for applications where ambient temperatures fall below 0°C.

Capacitor Table

Table 1 identifies the characteristics of capacitors from a number of vendors with acceptable ESR and ripple current (rms) ratings. The number of capacitors required at both the input and output buses is identified for each capacitor type.

This is not an extensive capacitor list. Capacitors from other vendors are available with comparable specifications. Those listed are for guidance. The RMS ripple current rating and ESR (Equivalent Series Resistance at 100kHz) are critical parameters necessary to insure both optimum regulator performance and long capacitor life.

Table 1: Input/Output Capacitors

Capacitor Vendor/ Component Series	Capacitor Characteristics					Quantity		Vendor Number
	Working Voltage	Value(µF)	(ESR) Equivalent Series Resistance	85°C Maximum Ripple Current(Irms)	Physical Size(mm)	Input Bus	Output Bus	
Panasonic FC	25V	560µF	0.0065Ω	1205mA	12.5x15	1	1	EEUFC1E561S
	35V	390µF	0.065Ω	1205mA	12.5x15	2	1	EEUFC1V391S
	35V	330µF	0.117Ω	555mA	8x11.5	N/R	1	EEUFC1C331
United Chemi-Con LXV/FS/LXZ	16V	330µF	0.120Ω	555mA	8x12	N/R	1	LXZ16VB331M8X12LL
	35V	470µF	0.052Ω	1220mA	10x20	1	1	LXZ35VB471M10X20LL
	10V	330µF	0.025Ω	3500mA	10x10.5	1	1	10FS330M
	20V	150µF	0.030+2 Ω	3200mA	10x10.5	2	2	20FS150M
Nichicon PL/ PM	35V	560µF	0.048Ω	1360mA	16x15	1	1	UPL1V561MHH6
	35V	330µF	0.065+2 Ω	1020mA	12.5x15	1	1	UPL1V331MHH6
	50V	470µF	0.046Ω	1470mA	18x15	1	1	UPM1H4711MHH6
Panasonic FC (Surface Mtg)	10V	1000µF	0.043Ω	1205mA	12x16.5	1	1	EEVFC1A102LQ
	35V	330µF	0.065Ω	1205mA	12.5x16	1	1	EEVFC1V331LQ
	16V	330µF	0.150Ω	670mA	10x10.2	N/R	1	EEVFC1C331P
Oscon- SS SV	10V	330µF	0.025Ω	>3500mA	10.0x10.5	1	1	10SS330M
	10V	330µF	0.025Ω	>3800mA	10.3x10.3	1	1	10SV300M
	20V	150µF	0.024+2 Ω	3600mA	10.3x10.3	2	2	20SV150M SV= Surface Mount
AVX Tantalum TPS	10V	330µF	0.100+2 Ω	>2500mA	7.3Lx	2	1	TPSV337M010R0100
	10V	330µF	0.100+2 Ω	>3000mA	4.3Wx	2	1	TPSV337M010R0060
	10V	220µF	0.095Ω	>2000mA	4.1H	2	2	TPSV227M0105R0100
Kemet T510/T495	10V	330µF	0.033Ω	1400mA	7.3Lx5.7W	2	1	T510X337M010AS
	10V	220µF	0.07Ω+2 =0.035Ω	>2000mA	x 4.0H	2	2	T495X227M010AS
Sprague 594D	10V	330µF	0.045Ω	2350mA	7.3Lx	2	1	4D337X0010R2T
	10V	220µF	0.065Ω	>2000mA	6.0Wx 4.1H	2	2	594D227X0010D2T

N/R –Not recommended. The ripple current rating and ESR does not meet the requirements.

IMPORTANT NOTICE

Texas Instruments Incorporated and its subsidiaries (TI) reserve the right to make corrections, modifications, enhancements, improvements, and other changes to its products and services at any time and to discontinue any product or service without notice. Customers should obtain the latest relevant information before placing orders and should verify that such information is current and complete. All products are sold subject to TI's terms and conditions of sale supplied at the time of order acknowledgment.

TI warrants performance of its hardware products to the specifications applicable at the time of sale in accordance with TI's standard warranty. Testing and other quality control techniques are used to the extent TI deems necessary to support this warranty. Except where mandated by government requirements, testing of all parameters of each product is not necessarily performed.

TI assumes no liability for applications assistance or customer product design. Customers are responsible for their products and applications using TI components. To minimize the risks associated with customer products and applications, customers should provide adequate design and operating safeguards.

TI does not warrant or represent that any license, either express or implied, is granted under any TI patent right, copyright, mask work right, or other TI intellectual property right relating to any combination, machine, or process in which TI products or services are used. Information published by TI regarding third-party products or services does not constitute a license from TI to use such products or services or a warranty or endorsement thereof. Use of such information may require a license from a third party under the patents or other intellectual property of the third party, or a license from TI under the patents or other intellectual property of TI.

Reproduction of information in TI data books or data sheets is permissible only if reproduction is without alteration and is accompanied by all associated warranties, conditions, limitations, and notices. Reproduction of this information with alteration is an unfair and deceptive business practice. TI is not responsible or liable for such altered documentation.

Resale of TI products or services with statements different from or beyond the parameters stated by TI for that product or service voids all express and any implied warranties for the associated TI product or service and is an unfair and deceptive business practice. TI is not responsible or liable for any such statements.

Mailing Address:

Texas Instruments
Post Office Box 655303
Dallas, Texas 75265

Looking for pricing, stock, or lifecycle information?

Click below to explore more details on WIN SOURCE:

 [View PT6523B on WIN SOURCE](#)

 [Texas Instruments](#) Information

Optimize Your Supply Chain with WIN SOURCE Solutions

-  Global Sourcing Solution
-  Obsolete Management
-  Cost Control Management
-  Shortage Management
-  Alternative Solution
-  Excess Inventory Management