



**THE DATASHEET OF
PTH12050LAZT**



6-A, 12-V INPUT NON-ISOLATED WIDE-OUTPUT ADJUST POWER MODULE



FEATURES

- Up to 6-A Output Current
- 12-V Input Voltage
- Wide-Output Voltage Adjust (1.2 V to 5.5 V)/(0.8 V to 1.8 V)
- Efficiencies up to 93%
- 200 W/in³ Power Density
- On/Off Inhibit
- Undervoltage Lockout
- Operating Temperature: –40°C to 85°C
- Auto-Track™ Sequencing
- Output Overcurrent Protection (Nonlatching, Auto-Reset)
- Safety Agency Approvals: UL/IEC/CSA-22.2 60950-1
- Point-of-Load Alliance (POLA™) Compatible

APPLICATIONS

- Telecom, Industrial, and General-Purpose Circuits



NOMINAL SIZE = 0.87 i x 0.5 i
(22,1 mm x 12,57 mm)



DESCRIPTION

The PTH12050 series is the smallest non-isolated power modules that features Auto-Track™ Sequencing. Auto-Track simplifies the sequencing of supply voltages in power systems by enabling modules to track each other, or any other external voltage, during power up and power down.

Although small in size (0.87 inches × 0.5 inches), these modules are rated for up to 6 A of output current, and are an ideal choice in applications where space, performance, and a power-up sequencing capability are important attributes.

The series operates from an input voltage of 12-V to provide step-down conversion to a wide range of output voltages. The output voltage of the W-suffix device may set to any voltage over the adjust range, 1.2 V to 5.5 V. The L-suffix device has an adjustment range of 0.8 V to 1.8 V. The output voltage is set within the adjustment range using a single external resistor.

Other operating features include an on/off inhibit, output voltage adjust (trim), and output overcurrent protection. For high efficiency, these parts employ a synchronous rectifier output stage.

Target applications include telecom, industrial, and general purpose circuits, including low-power dual-voltage systems that use the TMS320™ DSP family, microprocessor, ASIC, or FPGA.

For start-up into a non-prebiased output, review page 14 in the *Application Information* section.

For start-up into a prebiased output, review page 18 in the *Application Information* section.



Please be aware that an important notice concerning availability, standard warranty, and use in critical applications of Texas Instruments semiconductor products and disclaimers thereto appears at the end of this data sheet.

Auto-Track, POLA, TMS320 are trademarks of Texas Instruments.



These devices have limited built-in ESD protection. The leads should be shorted together or the device placed in conductive foam during storage or handling to prevent electrostatic damage to the MOS gates.

STANDARD APPLICATION

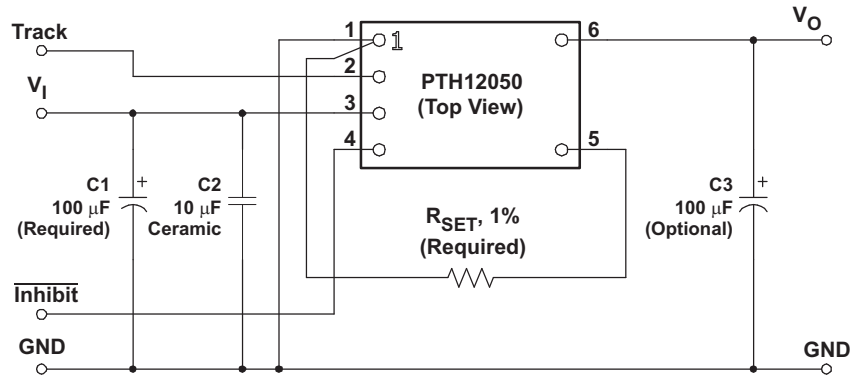

- A. R_{SET} = Required to set the output voltage higher than the minimum value. See the Application Information section for values.
- B. C₂ = 10 µF ceramic capacitor. Required for output voltages 3.3 V or higher.

ORDERING INFORMATION

For the most current package and ordering information, see the Package Option Addendum at the end of this datasheet, or see the TI website at www.ti.com.

ABSOLUTE MAXIMUM RATINGS

Over operating free-air temperature range unless otherwise noted
 All voltages are with respect to GND

			UNIT
V _I	Track input voltage		–0.3 V to V _I +0.3 V
T _A	Operating temperature range	Over V _I range	–40°C to 85°C
T _{wave}	Wave solder temperature	Surface temperature of module body or pins (5 = seconds)	PTH12050WAH 260°C ⁽¹⁾
T _{reflow}	Solder reflow temperature	Surface temperature of module body or pins	PTH12050WAS 235°C ⁽¹⁾
			PTH12050WAZ 260°C ⁽¹⁾
T _{stg}	Storage temperature		–55°C to 125°C ⁽²⁾
	Mechanical shock	Per Mil-STD-883D, Method 2002.3, 1 msec, = Sine, mounted	500 G
	Mechanical vibration	Mil-STD-883D, Method 2007.2, 20-2000 Hz	20 G
	Weight		2.9 grams
	Flammability	Meets UL 94V-O	

- (1) During soldering of package version, do not elevate peak temperature of the module, pins or internal components above the stated maximum.
- (2) The shipping tray or tape and reel cannot be used to bake parts at temperatures higher than 65°C.

ELECTRICAL CHARACTERISTICS

$T_A = 25^\circ\text{C}$; $V_I = 12\text{ V}$; $V_O = 3.3\text{ V}$; $C_1 = 100\ \mu\text{F}$, $C_2 = 10\ \mu\text{F}$, $C_3 = 0\ \mu\text{F}$, and $I_O = I_{O(\text{max})}$ (unless otherwise stated)

PARAMETER		TEST CONDITIONS		PTH12050W			UNIT
				MIN	TYP	MAX	
I_O	Output current	Over ΔV_{adj} range	85°C, 400 LFM airflow	0		6 ⁽¹⁾	A
			60°C, natural convection			6 ⁽¹⁾	A
V_I	Input voltage range	Over I_O range		10.8		13.2	V
$V_{O\ \text{tol}}$	Set-point voltage tolerance					± 2 ⁽²⁾	% V_O
$\Delta\text{Reg}_{\text{temp}}$	Temperature variation	$-40^\circ\text{C} < T_A < 85^\circ\text{C}$		± 0.5			% V_O
$\Delta\text{Reg}_{\text{line}}$	Line regulation	Over V_I range		± 5			mV
$\Delta\text{Reg}_{\text{load}}$	Load regulation	Over I_O range		± 5			mV
$\Delta\text{Reg}_{\text{tot}}$	Total output variation	Includes set-point, line, load, $-40^\circ\text{C} \leq T_A \leq 85^\circ\text{C}$				± 3 ⁽²⁾	% V_O
ΔV_{adj}	Output voltage adjust range	Over V_I range		1.2		5.5 ⁽¹⁾	V
η	Efficiency	$I_O = 5\text{ A}$	$R_{\text{SET}} = 280\ \Omega$, $V_O = 5\text{ V}$ ⁽¹⁾			93%	
			$R_{\text{SET}} = 2\text{ k}\Omega$, $V_O = 3.3\text{ V}$ ⁽¹⁾			91%	
			$R_{\text{SET}} = 4.32\text{ k}\Omega$, $V_O = 2.5\text{ V}$			89%	
			$R_{\text{SET}} = 8.06\text{ k}\Omega$, $V_O = 2\text{ V}$			88%	
			$R_{\text{SET}} = 11.5\text{ k}\Omega$, $V_O = 1.8\text{ V}$			87%	
			$R_{\text{SET}} = 24.3\text{ k}\Omega$, $V_O = 1.5\text{ V}$			86%	
			$R_{\text{SET}} = \text{open circuit}$, $V_O = 1.2\text{ V}$			84%	
V_r	V_O ripple (peak-to-peak)	20-MHz bandwidth	$V_O \leq 2.5\text{ V}$			25	mVpp
			$V_O > 2.5\text{ V}$			1	% V_O
I_{trip}	Overcurrent threshold	Reset, followed by auto-recovery				14	A
t_{tr}	Transient response	1 A/ μs load step, 50 to 100% $I_{O(\text{max})}$, $C_3 = 100\ \mu\text{F}$	Recovery time			70	μs
ΔV_{tr}			V_O over/undershoot			100	mV
$I_{\text{IL track}}$	Track input current (pin 2)	Pin to GND				-0.13 ⁽³⁾	mA
dV_{track}/dt	Track slew rate capability	$C_O \leq C_{O(\text{max})}$				1	V/ms
UVLO	Under-voltage lockout	V_I increasing		9.5		10.4	V
		V_I decreasing		8.8		9	V
V_{IH}	Inhibit Control (pin 4)	Input high voltage, Referenced to GND				Open ⁽³⁾	V
V_{IL}		Input low voltage, Referenced to GND		-0.2		0.5	V
I_{IL}		Input low current, Pin 4 to GND		0.24			mA
I_i	Input standby current	Inhibit (pin 4) to GND, Track (pin 2) open		10			mA
f_s	Switching frequency	Over V_I and I_O ranges		260	320	380	kHz
	External input capacitance, C_1			100 ⁽⁴⁾			μF
	External output capacitance, C_3	Capacitance value	Nonceramic	0	100 ⁽⁵⁾	3300 ⁽⁶⁾	μF
			Ceramic	0		300	μF
		Equivalent series resistance (nonceramic)			4 ⁽⁷⁾		
MTBF	Reliability	Per Bellcore TR-332 50% stress, $T_A = 40^\circ\text{C}$, ground benign		5.9			10^6 Hr

- (1) See the Temperature Derating (SOA) curves in the Typical Characteristics section for appropriate derating.
- (2) The set-point voltage tolerance is affected by the tolerance and stability of R_{SET} . The stated limit is unconditionally met if R_{SET} has a tolerance of 1% with 100 ppm/°C or better temperature stability.
- (3) This control pin has an internal pull-up to the input voltage V_I (7.5 V for pin 2). If it is left open-circuit, the module operates when input power is applied. A small, low-leakage (<100 nA) MOSFET or open-drain/collector voltage supervisor IC is recommended for control. Do not place an external pull-up on this pin. For further information, see the related application note.
- (4) A 100 μF electrolytic input capacitor is required for proper operation. The electrolytic capacitor must be rated for a minimum of 750 mA rms of ripple current. An additional 10 μF ceramic capacitor is required for output voltages 3.3 V and higher. For further information, see the related application information on capacitor selection.
- (5) An external output capacitor is not required for basic operation. Adding 100 μF of distributed capacitance at the load improves the transient response.
- (6) This is the calculated maximum. The minimum ESR limitation often results in a lower value. When controlling the Track pin using a voltage supervisor, $C_{O(\text{max})}$ is reduced to 2200 μF . See the application notes for further guidance.
- (7) This is the typical ESR for all the electrolytic (nonceramic) output capacitance. Use 7 m Ω as the minimum when using max-ESR values to calculate.

ELECTRICAL CHARACTERISTICS

$T_A = 25^\circ\text{C}$; $V_I = 12\text{ V}$; $V_O = 1.8\text{ V}$; $C_1 = 100\ \mu\text{F}$, $C_2 = 10\ \mu\text{F}$, $C_3 = 0\ \mu\text{F}$, and $I_O = I_{O(\text{max})}$ (unless otherwise stated)

PARAMETER		TEST CONDITIONS		PTH12050L			UNIT
				MIN	TYP	MAX	
I_O	Output current	Over ΔV_{adj} range	85°C, 400 LFM airflow	0		6 ⁽¹⁾	A
			60°C, natural convection			6 ⁽¹⁾	A
V_I	Input voltage range	Over I_O range		10.8		13.2	V
V_{Otol}	Set-point voltage tolerance					± 2 ⁽²⁾	% V_O
$\Delta \text{Reg}_{\text{temp}}$	Temperature variation	$-40^\circ\text{C} < T_A < 85^\circ\text{C}$		± 0.5			% V_O
$\Delta \text{Reg}_{\text{line}}$	Line regulation	Over V_I range		± 5			mV
$\Delta \text{Reg}_{\text{load}}$	Load regulation	Over I_O range		± 5			mV
$\Delta \text{Reg}_{\text{tot}}$	Total output variation	Includes set-point, line, load, $-40^\circ\text{C} \leq T_A \leq 85^\circ\text{C}$				± 3 ⁽²⁾	% V_O
$\Delta \text{Reg}_{\text{adj}}$	Output voltage adjust range	Over V_I range		0.8		1.8	V
η	Efficiency	$I_O = 5\text{ A}$	$R_{\text{SET}} = 130\ \Omega$, $V_O = 1.8\text{ V}$			88%	
			$R_{\text{SET}} = 3.57\text{ k}\Omega$, $V_O = 1.5\text{ V}$			87%	
			$R_{\text{SET}} = 12.1\text{ k}\Omega$, $V_O = 1.2\text{ V}$			85%	
			$R_{\text{SET}} = 32.4\text{ k}\Omega$, $V_O = 1\text{ V}$			83%	
			$R_{\text{SET}} = \text{open circuit}$, $V_O = 0.8\text{ V}$			81%	
V_r	V_O ripple (peak-to-peak)	20-MHz bandwidth	$V_O > 1\text{ V}$			30	mVpp
			$V_O \leq 1\text{ V}$			20	
$I_{\text{O,trip}}$	Overcurrent threshold	Reset, followed by auto-recovery				14	A
t_{tr}	Transient response	1 A/ μs load step, 50 to 100% $I_{O(\text{max})}$, $C_3 = 100\ \mu\text{F}$	Recovery time			70	μs
ΔV_r			V_O over/undershoot			100	mV
$I_{\text{IL, track}}$	Track input current (pin 2)	Pin to GND				-0.13 ⁽³⁾	mA
dV_{track}/dt	Track slew rate capability	$C_O \leq C_{O(\text{max})}$				1	V/ms
UVLO	Undervoltage lockout	V_I increasing		9.5		10.4	V
		V_I decreasing		8.8		9	
V_{IH}	Inhibit control (pin 4)	Input high voltage, Referenced to GND				Open ⁽³⁾	V
V_{IL}		Input low voltage, Referenced to GND			-0.2	0.5	
I_{IL}		Input low current, Pin 4 to GND				0.24	
I_i	Input standby current	Inhibit (pin 4) to GND, Track (pin 2) open				10	mA
f_s	Switching frequency	Over V_I and I_O ranges		200	250	300	kHz
	External input capacitance, C1			100 ⁽⁴⁾			μF
	External output capacitance, C3	Capacitance value	Nonceramic	0	100 ⁽⁵⁾	3300 ⁽⁶⁾	μF
			Ceramic	0		300	
		Equivalent series resistance (nonceramic)			4 ⁽⁷⁾		
MTBF	Reliability	Per Bellcore TR-332 50% stress, $T_A = 40^\circ\text{C}$, ground benign		5.9			10^6 Hr

- (1) See the Temperature Derating (SOA) curves in the Typical Characteristics section for appropriate derating.
- (2) The set-point voltage tolerance is affected by the tolerance and stability of R_{SET} . The stated limit is unconditionally met if R_{SET} has a tolerance of 1% with 100 ppm/°C or better temperature stability.
- (3) This control pin has an internal pull-up to the input voltage V_I (7.5 V for pin 2). If it is left open-circuit, the module operates when input power is applied. A small, low-leakage (<100 nA) MOSFET or open-drain/collector voltage supervisor IC is recommended for control. Do not place an external pull-up on this pin. For further information, see the related application note.
- (4) A 100 μF electrolytic input capacitor is required for proper operation. The electrolytic capacitor must be rated for a minimum of 750 mA rms of ripple current. An additional 10 μF ceramic capacitor is required for output voltages 3.3 V and higher. For further information, see the related application information on capacitor selection.
- (5) An external output capacitor is not required for basic operation. Adding 100 μF of distributed capacitance at the load improves the transient response.
- (6) This is the calculated maximum. The minimum ESR limitation often results in a lower value. When controlling the Track pin using a voltage supervisor, $C_{O(\text{max})}$ is reduced to 2200 μF . See the application notes for further guidance.
- (7) This is the typical ESR for all the electrolytic (nonceramic) output capacitance. Use 7 m Ω as the minimum when using max-ESR values to calculate.

DEVICE INFORMATION

Terminal Functions

TERMINAL		DESCRIPTION
NAME	NO.	
V_I	3	The positive input voltage power node to the module, which is referenced to common GND.
V_O	6	The regulated positive power output with respect to the GND node.
GND	1	This is the common ground connection for the V_I and V_O power connections. It is also the $0-V_{DC}$ reference for the control inputs.
V_O Adjust	5	A 1% resistor must be directly connected between this pin and GND (pin 1) to set the output voltage of the module to a value higher than its lowest value. The temperature stability of the resistor should be 100 ppm/°C (or better). The set-point range is 1.2 V to 5.5 V for W-suffix devices, and 0.8 V to 1.8 V for L-suffix devices. The resistor value required for a given output voltage may be calculated using a formula. If left open circuit, the output voltage defaults to its lowest value. For further information on output voltage adjustment, see the related application note. The specification table gives the preferred resistor values for a number of standard output voltages.
Inhibit	4	The Inhibit pin is an open-collector/drain negative logic input that is referenced to GND. Applying a low-level ground signal to this input disables the module's output and turns off the output voltage. When the Inhibit control is active, the input current drawn by the regulator is significantly reduced. If the Inhibit pin is left open circuit, the module produces an output whenever a valid input source is applied. Do not place an external pull-up on this pin. <i>For power-up into a non-prebiased output, it is recommended that AutoTrack be utilized for On/Off control. See the Application Information for additional details.</i>
Track	2	This is an analog control input that enables the output voltage to follow an external voltage. This pin becomes active typically 20 ms after the input voltage has been applied, and allows direct control of the output voltage from 0 V up to the nominal set-point voltage. Within this range, the output follows the voltage at the Track pin on a volt-for-volt basis. When the control voltage is raised above this range, the module regulates at its set-point voltage. The feature allows the output voltage to rise simultaneously with other modules powered from the same input bus. If unused, the input should be connected to V_I . <i>Note: Due to the under-voltage lockout feature, the output of the module cannot follow its own input voltage during power up. For more information, see the related application note.</i>

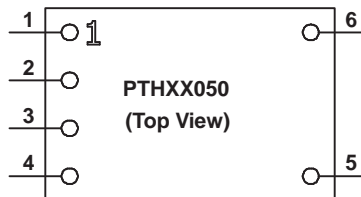

PTH12050W TYPICAL CHARACTERISTICS ($V_I = 12\text{ V}$)⁽¹⁾⁽²⁾

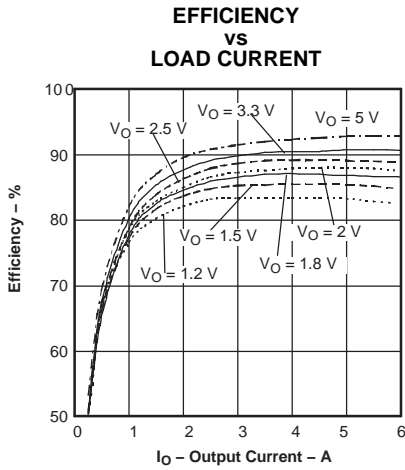

Figure 1.

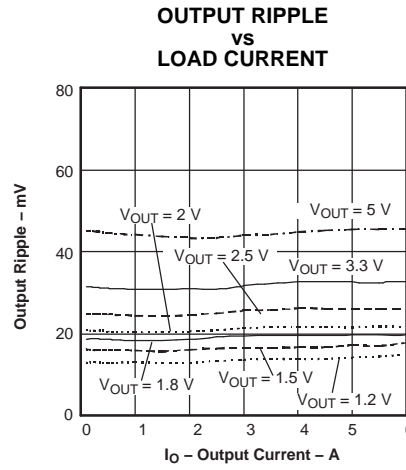

Figure 2.

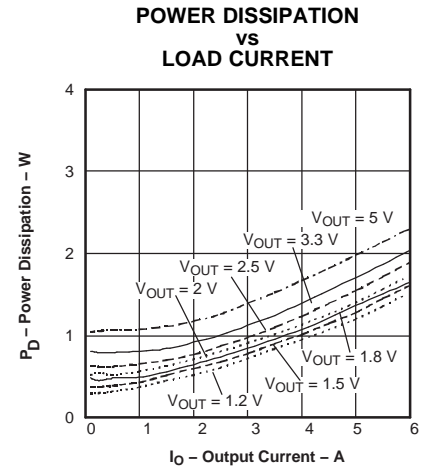

Figure 3.

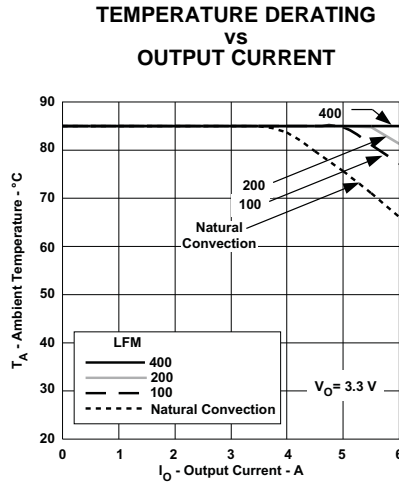

Figure 4.

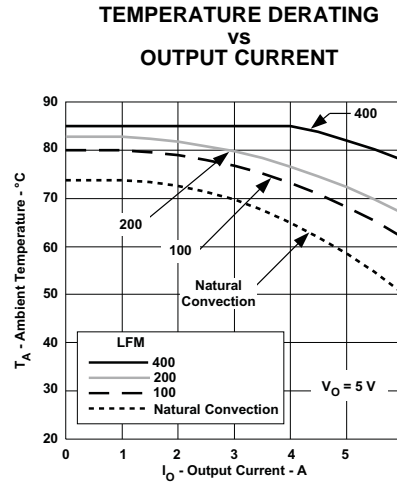

Figure 5.

- (1) Characteristic data has been developed from actual products tested at 25°C. This data is considered typical data for the converter. Applies to [Figure 1](#), [Figure 2](#), and [Figure 3](#).
- (2) SOA graphs represent the conditions at which internal components are at or below the manufacturer's maximum operating temperatures. Derating limits apply to modules soldered directly to a 4 inches × 4 inches double-sided PCB with 1-oz. copper. For surface mount packages (AS and AZ suffix), multiple vias (plated through holes) are required to add thermal paths around the power pins. Please refer to the mechanical specification for more information. Applies to [Figure 4](#).

PTH12050L TYPICAL CHARACTERISTICS ($V_I = 12\text{ V}$)⁽¹⁾⁽²⁾

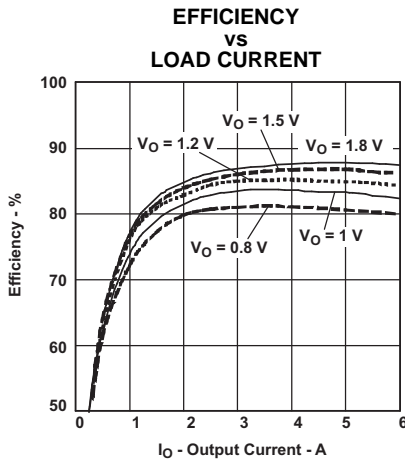

Figure 6.

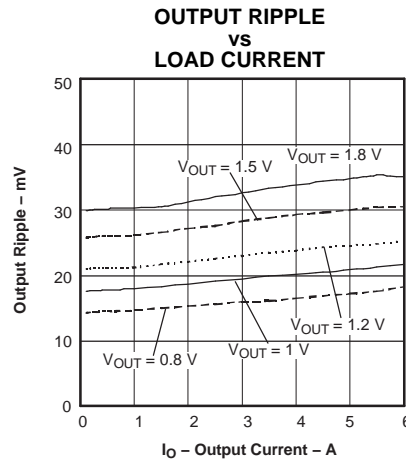

Figure 7.

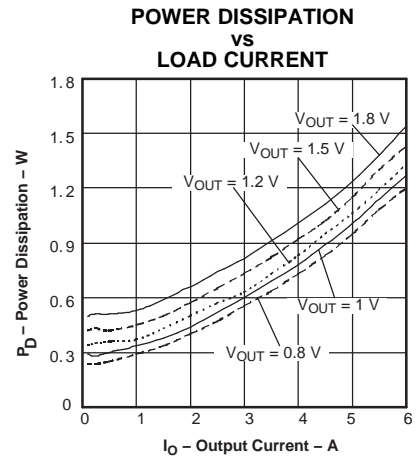

Figure 8.

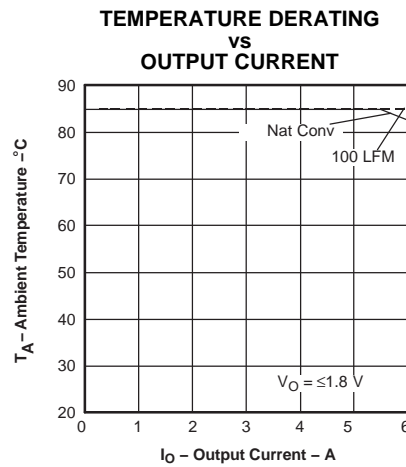

Figure 9.

- (1) Characteristic data has been developed from actual products tested at 25°C. This data is considered typical data for the converter. Applies to [Figure 6](#), [Figure 7](#), and [Figure 8](#).
- (2) SOA graphs represent the conditions at which internal components are at or below the manufacturer's maximum operating temperatures. Derating limits apply to modules soldered directly to a 4 inches × 4 inches double-sided PCB with 1-oz. copper. For surface mount packages (AS and AZ suffix), multiple vias (plated through holes) are required to add thermal paths around the power pins. Please refer to the mechanical specification for more information. Applies to [Figure 9](#).

APPLICATION INFORMATION

ADJUSTING THE OUTPUT VOLTAGE

The $V_{OAdjust}$ control (pin 5) sets the output voltage of the PTH12050 product. The adjustment range is from 1.2 V to 5.5 V for the W-suffix modules and 0.8 V to 1.8 V for L-suffix modules. The adjustment method requires the addition of a single external resistor, R_{SET} , that must be connected directly between the $V_{OAdjust}$ and GND pins. Table 1 gives the standard value of the external resistor for a number of standard voltages, along with the actual output voltage that this resistance value provides. For other output voltages, the value of the required resistor can either be calculated using Equation 1, or simply selected from the range of values given in Table 3. Figure 10 shows the placement of the required resistor.

Table 1. Standard Values of R_{SET} for Standard Output Voltages

V_O (Required) (V)	PTH12050W		PTH12050L				
	R_{SET} (k Ω)	V_O (Actual) (V)	R_{SET} (k Ω)	V_O (Actual) (V)			
5	0.280	5.009	N/A	N/A			
3.3	2.0	3.294	N/A	N/A			
2.5	4.32	2.503	N/A	N/A			
2	8.06	2.010	N/A	N/A			
1.8	11.5	1.801	0.130	1.800			
1.5	24.3	1.506	3.57	1.499			
1.2	Open	1.200	12.1	1.201			
1.1	N/A	N/A	18.7	1.101			
1.0	N/A	N/A	32.4	0.999			
0.9	N/A	N/A </tr <tr> <td>0.8</td> <td>N/A</td> <td>N/A</td> <td>Open</td> <td>0.800</td> </tr>	0.8	N/A	N/A	Open	0.800
0.8	N/A	N/A	Open	0.800			

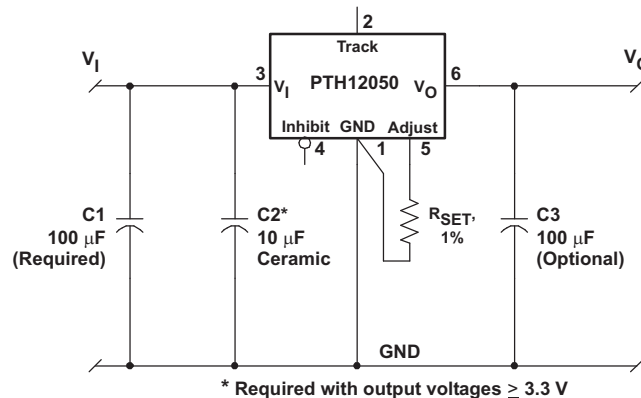

- (1) A 0.05-W rated resistor can be used. The tolerance should be 1%, with a temperature stability of 100 ppm/ $^{\circ}$ C or better. Place the resistor as close to the regulator as possible. Connect the resistor directly between pins 5 and 1 using dedicated PCB traces.
- (2) Never connect capacitors from $V_{OAdjust}$ to either GND or V_O . Any capacitance added to the $V_{OAdjust}$ pin affects the stability of the regulator.

Figure 10. $V_{OAdjust}$ Resistor Placement

Use [Equation 1](#) to calculate the adjust resistor value. See [Table 2](#) for parameters, R_S and V_{min} .

Equation 1. Output Voltage Adjust

Table 2. Adjust Formula Parameters

OUTPUT VOLTAGE ADJUST EQUATION	Parameter	PTH12050W	PTH12050L
$R_{set} = 10 \text{ k}\Omega \times \frac{0.8 \text{ V}}{V_{out} - V_{min}} - R_S \text{ k}\Omega$ (1)	$V_{(MIN)}$	1.2 V	0.8 V
	$V_{(MAX)}$	5.5 V	1.8 V
	R_S	1.82 k Ω	7.87 k Ω

Table 3. Output Voltage Set-Point Resistor Values

PTH12050W				PTH12050L	
V_O (V)	R_{SET} (k Ω)	V_O (V)	R_{SET} (k Ω)	V_O (V)	R_{SET} (k Ω)
1.200	Open	2.7	3.51	0.8	Open
1.225	318	2.75	3.34	0.825	312
1.250	158	2.8	3.18	0.85	152
1.275	105	2.85	3.03	0.875	98.8
1.300	78.2	2.9	2.89	0.9	72.1
1.325	62.2	2.95	2.75	0.925	56.1
1.350	51.1	3.0	2.62	0.95	45.5
1.375	43.9	3.05	2.49	0.975	37.8
1.400	38.2	3.1	2.39	1.0	32.1
1.425	33.7	3.15	2.27	1.025	27.7
1.450	30.2	3.2	2.18	1.05	24.1
1.475	27.3	3.25	2.08	1.075	21.2
1.50	24.8	3.3	1.99	1.1	18.8
1.55	21	3.35	1.91	1.125	16.7
1.60	18.2	3.4	1.82	1.15	15
1.65	16	3.5	1.66	1.175	13.5
1.70	14.2	3.6	1.51	1.2	12.1
1.75	12.7	3.7	1.38	1.225	11
1.80	11.5	3.8	1.26	1.25	9.91
1.85	10.5	3.9	1.14	1.275	8.97
1.90	9.61	4.0	1.04	1.3	8.13
1.95	8.85	4.1	0.939	1.325	7.37
2.00	8.18	4.2	0.847	1.35	6.68
2.05	7.59	4.3	0.761	1.375	6.04
2.10	7.07	4.4	0.680	1.4	5.46
2.15	6.6	4.5	0.604	1.425	4.93
2.20	6.18	4.6	0.533	1.45	4.44
2.25	5.8	4.7	0.466	1.475	3.98
2.30	5.45	4.8	0.402	1.5	3.56
2.35	5.14	4.9	0.342	1.55	2.8
2.40	4.85	5.0	0.285	1.6	2.13
2.45	4.58	5.1	0.231	1.65	1.54
2.50	4.33	5.2	0.180	1.7	1.02
2.55	4.11	5.3	0.131	1.75	0.551
2.60	3.89	5.4	0.085	1.8	0.130
2.65	3.7	5.5	0.041		

CAPACITOR RECOMMENDATIONS FOR THE PTH12050 SERIES OF POWER MODULES

Input Capacitor

The recommended input capacitor(s) is determined by the 100 μF minimum capacitance and 750 mArms minimum ripple current rating. A 10- μF X5R/X7R ceramic capacitor may also be added to reduce the reflected input ripple current. This is recommended for output voltage set points of 3.3 V and higher.

Ripple current, less than 100 m Ω equivalent series resistance (ESR) and temperature are major considerations when selecting input capacitors. Unlike polymer-tantalum capacitors, regular tantalum capacitors have a recommended minimum voltage rating of $2 \times$ (maximum dc voltage + ac ripple). This is standard practice to ensure reliability. Only a few tantalum capacitors have sufficient voltage rating to meet this requirement. At temperatures below 0°C, the ESR of aluminum electrolytic capacitors increases. For these applications, Os-Con types, polymer-tantalum, and polymer-aluminum types should be considered.

Output Capacitors (Optional)

For applications with load transients (sudden changes in load current), regulator response benefits from external output capacitance. The value of 100 μF is used to define the transient response specification. For most applications, a high quality computer-grade aluminum electrolytic capacitor is adequate. These capacitors provide decoupling over the frequency range, 2 kHz to 150 kHz, and are suitable for ambient temperatures above 0°C. Below 0°C, tantalum, ceramic or Os-Con type capacitors are recommended. When using one or more nonceramic capacitors, the calculated equivalent ESR should be no lower than 4 m Ω (7 m Ω using the manufacturer's maximum ESR for a single capacitor). A list of preferred low-ESR type capacitors are identified in [Table 4](#).

In addition to electrolytic capacitance, adding a 10- μF X5R/X7R ceramic capacitor to the output reduces the output ripple voltage and improve the regulator's transient response. The measurement of both the output ripple and transient response is also best achieved across a 10- μF ceramic capacitor.

Ceramic Capacitors

Above 150 kHz the performance of aluminum electrolytic capacitors is less effective. Multilayer ceramic capacitors have very low ESR and a resonant frequency higher than the bandwidth of the regulator. They can be used to reduce the reflected ripple current at the input as well as improve the transient response of the output. When used on the output their combined ESR is not critical as long as the total value of ceramic capacitance does not exceed 300 μF . Also, to prevent the formation of local resonances, do not place more than five identical ceramic capacitors in parallel with values of 10 μF or greater.

Tantalum Capacitors

Tantalum type capacitors are most suited for use on the output bus, and are recommended for applications where the ambient operating temperature can be less than 0°C. The AVX TPS, Sprague 593D/594/595 and Kemet T495/ T510 capacitor series are suggested over other tantalum types due to their higher rated surge, power dissipation, and ripple current capability. As a caution many general purpose tantalum capacitors have considerably higher ESR, reduced power dissipation and lower ripple current capability. These capacitors are also less reliable as they have no surge current rating. Tantalum capacitors that do not have a stated ESR or surge current rating are not recommended for power applications.

When specifying Os-con and polymer tantalum capacitors for the output, the minimum ESR limit are encountered well before the maximum capacitance value is reached.

Capacitor Table

[Table 1](#) identifies the characteristics of capacitors from number of vendors with acceptable ESR and ripple current (rms) ratings. The recommended number of capacitors required at both the input and output buses is identified for each capacitor type.

This is not an extensive capacitor list. Capacitors from other vendors are available with comparable specifications. Those listed are for guidance. The RMS ripple current rating and ESR (at 100 kHz) are critical parameters necessary to insure both optimum regulator performance and long capacitor life.

Table 4. Input/Output Capacitors⁽¹⁾

Capacitor Vendor, Type/Series (Style)	Capacitor Characteristics					Quantity		Vendor Number
	Working Voltage (V)	Value (µF)	Max ESR at 100 kHz (Ω)	Max Ripple Current at 85°C (I _{rms}) (mA)	Physical Size (mm)	Input Bus	Output Bus	
Panasonic, Aluminum	25	330	0.090	775	10 × 12,5	1	1	EEUFC1E331
FC (Radial)	35	180	0.090	775	10 × 12,5	1	1	EEUFC1V181
FK (SMD)	25	470	0.080	850	10 × 10,2	1	1	EEVFK1E471P
United Chemi-Con								
PXA-Poly-Aluminum (SMD)	16	150	0.026	3430	10 × 7,7	1	≤4	PXA16VC151MJ80TP
PS (Radial)	20	100	0.024	3300	8 × 11,5	1	≤4	20PS100MH11
LXZ, Aluminum (Radial)	35	220	0.090	760	10 × 12,5	1	1	LXZ35VB221M10X12LL
Nichicon Aluminum								
HD (Radial)	25	220	0.072	760	8 × 11,5	1	1	UHD1E221MPR
PM (Radial)	35	220	0.090	770	10 × 15	1	1	UPM1V221MHH6
Panasonic, Poly-Aluminum S/SE (SMD)	6.3 ⁽²⁾	180	0.005	4000	7,3 × 4,3 × 4,2	N/R ⁽³⁾	≤1	EEFSE0J181R (V _O ≤ 5.1 V)
Sanyo								
SVP, Os-con (SMD)	20	100	0.024	>3300	8 × 12	1	≤4	20SVP100M
SEQP, Os-con (Radial)	20	100	0.024	>3300	8 × 12	1	≤4	20SEQP100M
TPE, Pos-Cap (SMD)	10	220	0.025	>2400	7,3 × 5,7	N/R ⁽³⁾	≤4	10TPE220ML
AVX, Tantalum	10	100	0.100	>1090	7,3×4,3×4,1	N/R ⁽³⁾	≤5	TPSD107M010R0100
TPS (SMD)	10	220	0.100	>1414	7,3×4,3×4,1	N/R ⁽³⁾	≤5	TPSV227M010R0100
	25	68	0.095	>1451	7,3×4,3×4,1	2	≤5	TPSV686M025R0080
Kemet								
T520, Poy-Tant (SMD)	10	100	0.080	1200	7,3x5,7x4	N/R ⁽³⁾	≤5	T520D107M010AS
T495, Tantalum (SMD)	10	100	0.100	>1100	7,3x5,7x4	N/R ⁽³⁾	≤5	T495X107M010AS
Vishay-Sprague								
594D, Tantalum (SMD)	10	150	0.090	1100	7,3×6×4,1	N/R ⁽³⁾	≤5	594D157X0010C2T
	25	68	0.095	1600	7,3×6×4,1	2	≤5	594D686X0025R2T
94SP, Organic (Radial)	16	100	0.070	2890	10 × 10,5	1	≤5	94SP107X0016FBP
94SVP, Organic (SMD)	20	100	0.025	3260	8 × 12	1	≤4	94SVP107X0020E12
Kemet, Ceramic X5R (SMD)	16	10	0.002	–	1210 case	1 ⁽⁴⁾	≤5	C1210C106M4PAC
	6.3	47	0.002	–	3225 mm	N/R ⁽³⁾	≤5	C1210C476K9PAC
Murata, Ceramic X5R (SMD)	6.3	100	0.002	–	1210 case	N/R ⁽³⁾	≤3	GRM32ER60J107M
	6.3	47	–	–	3225 mm	N/R ⁽³⁾	≤5	GRM32ER60J476M
	16	22	–	–	–	1 ⁽⁴⁾	≤5	GRM32ER61C226L
	16	10	–	–	–	1 ⁽⁴⁾	≤5	GRM32DR61C106K
TDK, Ceramic X5R (SMD)	6.3	100	0.002	–	1210 case	N/R ⁽³⁾	≤3	C3225X5ROJ107MT
	6.3	47	–	–	3225 mm	N/R ⁽³⁾	≤5	C3225X5ROJ476MT
	16	22	–	–	–	1 ⁽⁴⁾	≤5	C3225X5R1C226MT
	16	10	–	–	–	1 ⁽⁴⁾	≤5	C3225X5R1C106MT

(1) Capacitor Supplier Verification

Please verify availability of capacitors identified in this table. Capacitor suppliers may recommend alternative part numbers because of limited availability or obsolete products. In some instances, the capacitor product life cycle may be in decline and have short-term consideration for obsolescence.

RoHS, Lead-free and Material Details

Please consult capacitor suppliers regarding material composition, RoHS status, lead-free status, and manufacturing process requirements. Component designators or part number deviations can occur when material composition or soldering requirements are updated.

- (2) The voltage rating of this capacitor only allows it to be used for output voltages that are equal to or less than 5.1 V.
- (3) N/R – Not recommended. The capacitor voltage rating does not meet the minimum operating limits.
- (4) Ceramic capacitors are required to complement electrolytic types at the input and to reduce high-frequency ripple current.

Designing for Very Fast Load Transients

The transient response of the dc/dc converter has been characterized using a load transient with a di/dt of 1 A/μs. The typical voltage deviation for this load transient is given in the data sheet specification table using the optional value of output capacitance. As the di/dt of a transient is increased, the response of a converter's regulation circuit ultimately depends on its output capacitor decoupling network. This is an inherent limitation with any dc/dc converter once the speed of the transient exceeds its bandwidth capability. If the target application specifies a higher di/dt or lower voltage deviation, the requirement can only be met with additional output capacitor decoupling. In these cases special attention must be paid to the type, value and ESR of the capacitors selected.

If the transient performance requirements exceed that specified in the data sheet, or the total amount of load capacitance is above 3,000 μF, the selection of output capacitors becomes more important.

Features of the PTH Family of Non-Isolated Wide Output Adjust Power Modules

Introduction

The PTH/PTV family of non-isolated, wide-output adjustable power modules are optimized for applications that require a flexible, high performance module that is small in size. Each of these products are POLA™ compatible. POLA-compatible products are produced by a number of manufacturers, and offer customers advanced, nonisolated modules with the same footprint and form factor. POLA parts are also ensured to be interoperable, thereby, providing customers with second-source availability.

From the basic, *Just Plug It In* functionality of the 6-A modules, to the 30-A rated feature-rich PTHxx030, these products were designed to be very flexible, yet simple to use. The features vary with each product. Table 5 provides a quick reference to the features by product series and input bus voltage.

Table 5. Operating Features by Series and Input Bus Voltage

Series	Input Bus (V)	I _o (A)	Adjust (Trim)	On/Off Inhibit	Over-Current	Prebias Startup	Auto-Track™	Margin Up/Down	Output Sense	Thermal Shutdown
PTHxx050	3.3	6	•	•	•	•	•			
	5	6	•	•	•	•	•			
	12	6	•	•	•	•	•			
PTHxx060	3.3 / 5	10	•	•	•	•	•	•	•	
	12	10	•	•	•	•	•	•	•	
PTHxx010	3.3 / 5	15	•	•	•	•	•	•	•	
	12	12	•	•	•	•	•	•	•	
PTVxx010	5	8	•	•	•	•	•			
	12	8	•	•	•	•	•			
PTHxx020	3.3 / 5	22	•	•	•	•	•	•	•	•
	12	18	•	•	•	•	•	•	•	•
PTVxx020	5	18	•	•	•	•	•		•	•
	12	16	•	•	•	•	•		•	•
PTHxx030	3.3 / 5	30	•	•	•	•	•	•	•	•
	12	26	•	•	•	•	•	•	•	•

For simple point-of-use applications, the PTH12050 (6 A) provides operating features such as an on/off inhibit, output voltage trim, prebias start-up and overcurrent protection. The PTH12060 (10 A), and PTH12010 (12 A) include an output voltage sense, and margin up/down controls. Then the higher output current, PTH12020 (18 A) and PTH12030 (26 A) products incorporate overtemperature shutdown protection.

The PTV12010 and PTV12020 are similar parts offered in a vertical, single in-line pin (SIP) profile, at slightly lower current ratings.

All of the products referenced in [Table 5](#) include Auto-Track™. This feature was specifically designed to simplify the task of sequencing the supply voltages in a power system. This and other features are described in the following sections.

POWER-UP INTO A NON-PREBIASED OUTPUT — AUTO-TRACK™ FUNCTION

The Auto-Track function is unique to the PTH/PTV family, and is available with all POLA products. Auto-Track was designed to simplify the amount of circuitry required to make the output voltage from each module power up and power down in sequence. The sequencing of two or more supply voltages during power up is a common requirement for complex mixed-signal applications that use dual-voltage VLSI ICs such as the TMS320™ DSP family, microprocessors, and ASICs.

Basic Power-Up Using Auto-Track™

For applications requiring output voltage on/off control, each series of the PTH family incorporates the track control pin. The Auto-Track feature should be used instead of the inhibit feature wherever there is a requirement for the output voltage from the regulator to be turned on/off.

Figure 11 shows the typical application for basic start-up. Note the discrete transistor (Q1). The track input has its own internal pull-up to a potential of 5 V to 13.2 V. The input is not compatible with TTL logic devices. An open-collector (or open-drain) discrete transistor or supply voltage supervisor (TPS3808 or TPS7712) is recommended for control.

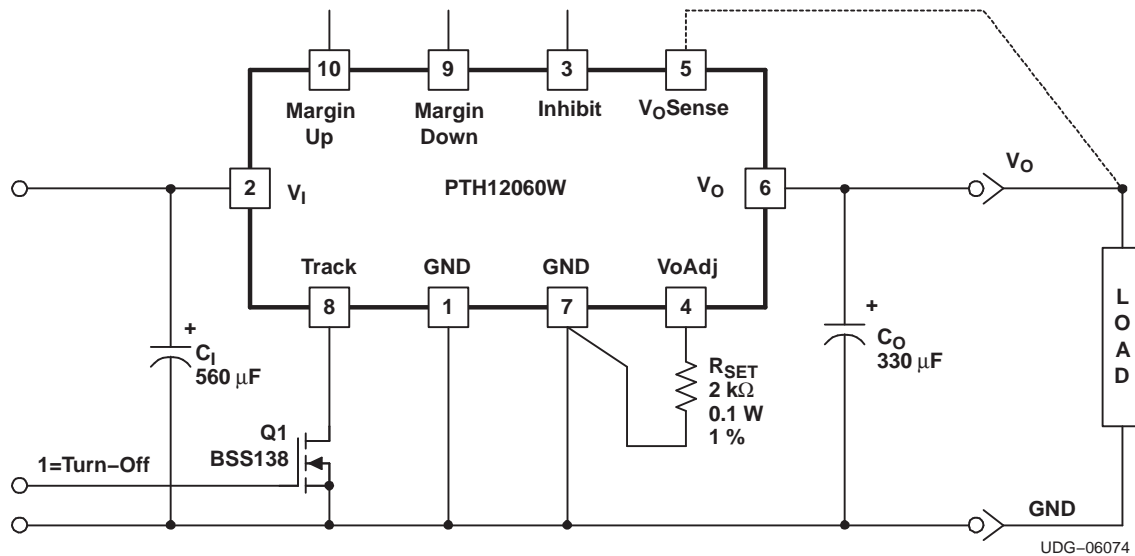

Figure 11. Basic Start-up Control Circuit

Turning on Q1 applies a low voltage to the track control pin and disables the output of the module. If Q1 is then turned off, the output ramps immediately to the regulated output voltage. A regulated output voltage is produced within 35 ms. With the initial application of the input source voltage, the track pin must be held low (Q1 turned ON) for at least 40 ms. Figure 12 shows the typical rise in both the output voltage and input current, following the turn off of Q1. The turn off of Q1 corresponds to the rise in the waveform, Q1 Vds. The waveforms were measured with a 10-A constant current load.

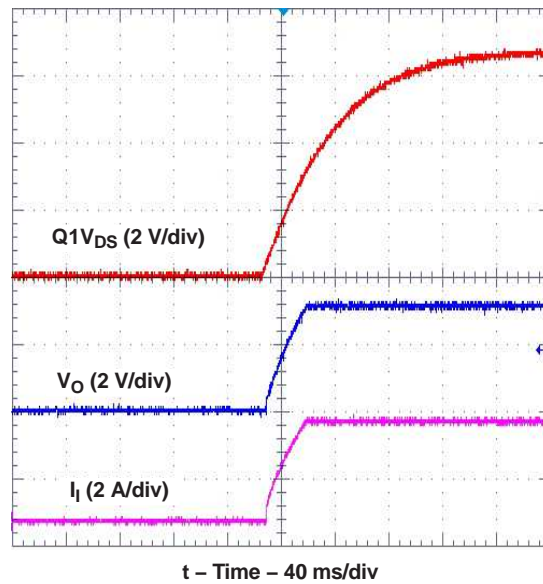

Figure 12. Power-Up from Track Control

NOTE:

If a prebias condition is not present, it is highly recommended that the Track control pin be used for controlled power-up and power-down. If Track control is not used, the output voltage starts up and overshoots by as much as 10%, before settling at the output voltage setpoint.

How Auto-Track™ Works

Auto-Track works by forcing the module output voltage to follow a voltage presented at the *Track* control pin ⁽¹⁾. This control range is limited to between 0 V and the module set-point voltage. Once the track-pin voltage is raised above the set-point voltage, the module output remains at its set-point ⁽²⁾. As an example, if the *Track* pin of a 2.5-V regulator is at 1 V, the regulated output is 1 V. If the voltage at the *Track* pin rises to 3 V, the regulated output does not go higher than 2.5 V.

When under Auto-Track control, the regulated output from the module follows the voltage at its *Track* pin on a volt-for-volt basis. By connecting the *Track* pin of a number of these modules together, the output voltages follow a common signal during power up and power down. The control signal can be an externally generated master ramp waveform, or the output voltage from another power supply circuit ⁽³⁾. For convenience, the *Track* input incorporates an internal RC-charge circuit. This operates off the module input voltage to produce a suitable rising waveform at power up.

Typical Auto-Track Application

The basic implementation of Auto-Track allows for simultaneous voltage sequencing of a number of Auto-Track compliant modules. Connecting the *Track* inputs of two or more modules forces their track input to follow the same collective RC-ramp waveform, and allows their power-up sequence to be coordinated from a common Track control signal. This can be an open-collector (or open-drain) device, such as a power-up reset voltage supervisor IC. See U3 in [Figure 13](#).

To coordinate a power-up sequence, the Track control must first be pulled to ground potential through R_{TRK} as defined in [Figure 13](#). This should be done at or before input power is applied to the modules. The ground signal should be maintained for at least 40 ms after input power has been applied. This brief period gives the modules time to complete their internal soft-start initialization⁽⁴⁾, enabling them to produce an output voltage. A low-cost supply voltage supervisor IC, that includes a built-in time delay, is an ideal component for automatically controlling the Track inputs at power up.

[Figure 13](#) shows how the TL7712A supply voltage supervisor IC (U3) can be used to coordinate the sequenced power up of two 12-V input Auto-Track modules. The output of the TL7712A supervisor becomes active above an input voltage of 3.6 V, enabling it to assert a ground signal to the common track control well before the input voltage has reached the module's undervoltage lockout threshold. The ground signal is maintained until approximately 43 ms after the input voltage has risen above U3's voltage threshold, which is 10.95 V. The 43-ms time period is controlled by the capacitor C3. The value of 3.3 μ F provides sufficient time delay for the modules to complete their internal soft-start initialization. The output voltage of each module remains at zero until the track control voltage is allowed to rise. When U3 removes the ground signal, the track control voltage automatically rises. This causes the output voltage of each module to rise simultaneously with the other modules, until each reaches its respective set-point voltage.

[Figure 14](#) shows the output voltage waveforms from the circuit of [Figure 13](#) after input voltage is applied to the circuit. The waveforms, V_{O1} and V_{O2} , represent the output voltages from the two power modules, U1 (3.3 V) and U2 (1.8 V), respectively. V_{TRK} , V_{O1} , and V_{O2} are shown rising together to produce the desired simultaneous power-up characteristic.

The same circuit also provides a power-down sequence. When the input voltage falls below U3's voltage threshold, the ground signal is re-applied to the common track control. This pulls the track inputs to zero volts, forcing the output of each module to follow, as shown in [Figure 15](#). In order for a simultaneous power-down to occur, the track inputs must be pulled low before the input voltage has fallen below the modules' undervoltage lockout. This is an important constraint. Once the modules recognize that a valid input voltage is no longer present, their outputs can no longer follow the voltage applied at their track input. During a power-down sequence, the fall in the output voltage from the modules is limited by the maximum output capacitance and the Auto-Track slew rate. If the *Track* pin is pulled low at a slew rate greater than 1 V/ms, the discharge of the output capacitors will induce large currents which could exceed the peak current rating of the module. This will result in a reduction in the maximum allowable output capacitance as listed in the Electrical Characteristics table. When controlling the *Track* pin of the PTH12060W using a voltage supervisor IC, the slew rate is increased, therefore C_{Omax} is reduced to 2200 μ F.

Notes on Use of Auto-Track™

1. The *Track* pin voltage must be allowed to rise above the module set-point voltage before the module regulates at its adjusted set-point voltage.
2. The Auto-Track function tracks almost any voltage ramp during power up, and is compatible with ramp speeds of up to 1 V/ms.
3. The absolute maximum voltage that may be applied to the *Track* pin is the input voltage V_I .
4. The module cannot follow a voltage at its track control input until it has completed its soft-start initialization. This takes about 40 ms from the time that a valid voltage has been applied to its input. During this period, it is recommended that the *Track* pin be held at ground potential.
5. The Auto-Track function is disabled by connecting the *Track* pin to the input voltage (V_I). When Auto-Track is disabled, the output voltage rises at a quicker and more linear rate after input power has been applied.

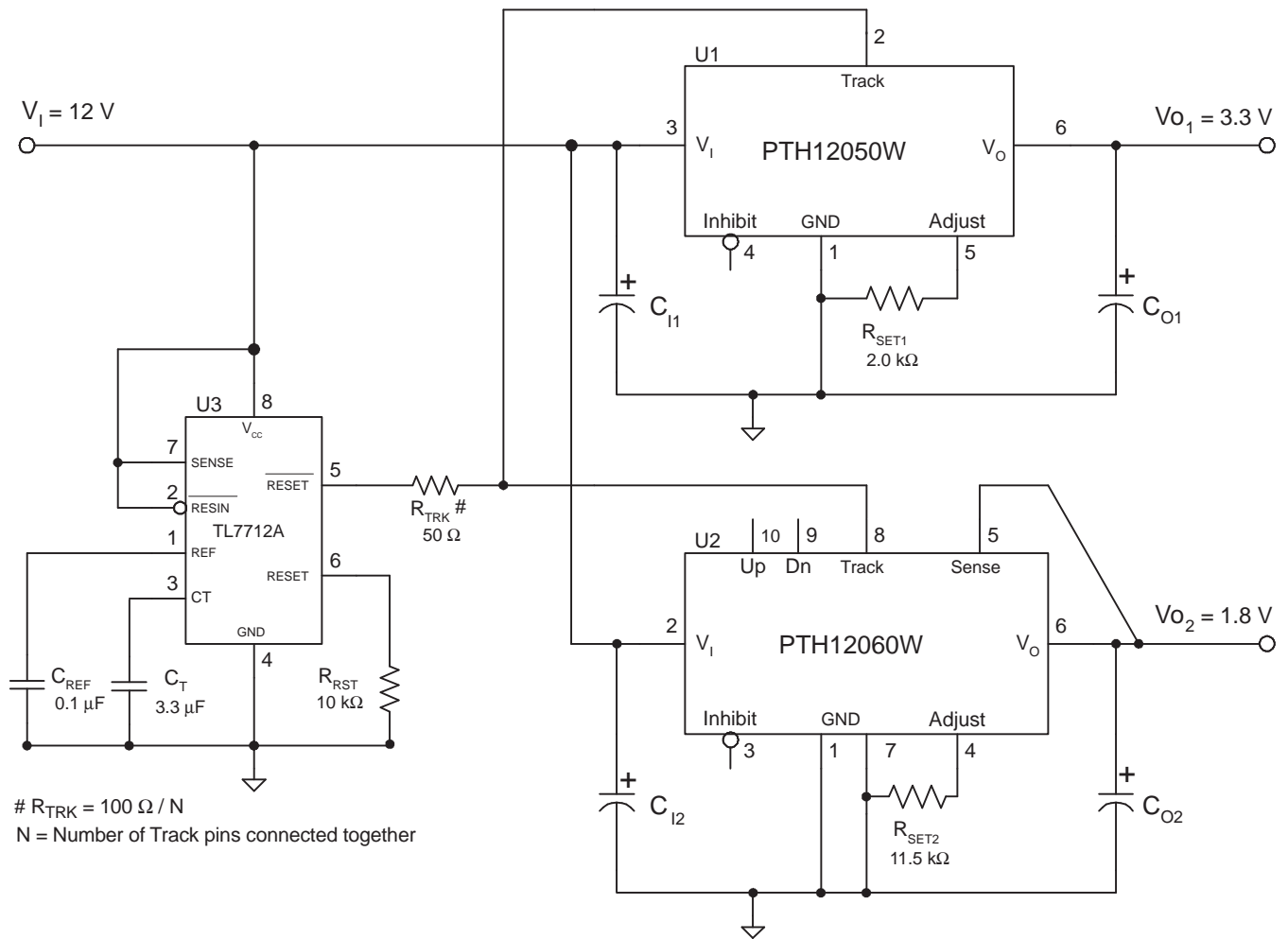

Figure 13. Sequenced Power Up and Power Down Using Auto-Track

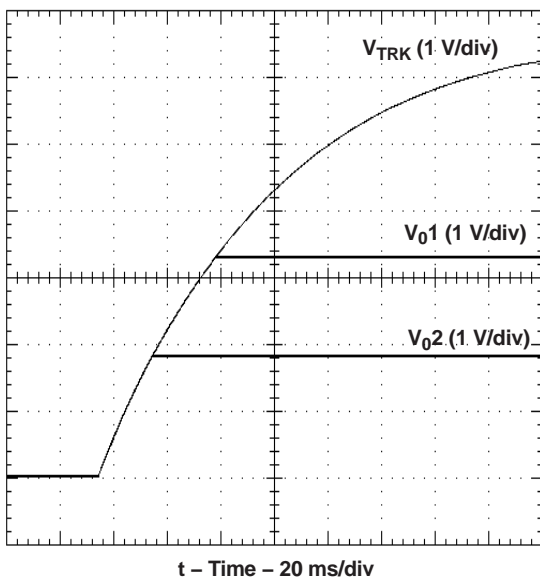

Figure 14. Simultaneous Power Up With Auto-Track Control

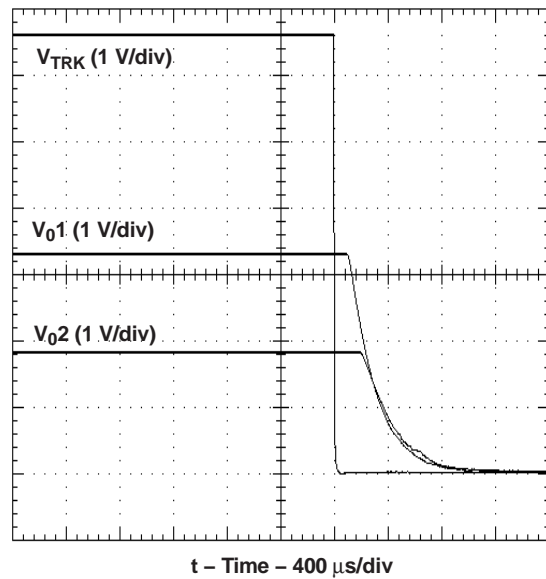

Figure 15. Simultaneous Power Down with Auto-Track Control

POWER-UP INTO A PREBIASED OUTPUT — START-UP USING INHIBIT CONTROL

The capability to start up into an output prebias condition is now available to all the 12-V input, PTH series of power modules. (Note that this is a feature enhancement for the many of the W-suffix products) ^[1].

A prebias startup condition occurs as a result of an external voltage being present at the output of a power module prior to its output becoming active. This often occurs in complex digital systems when current from another power source is backed through a dual-supply logic component, such as an FPGA or ASIC. Another path might be via clamp diodes, sometimes used as part of a dual-supply power-up sequencing arrangement. A prebias can cause problems with power modules that incorporate synchronous rectifiers. This is because under most operating conditions, such modules can sink as well as source output current. The 12-V input PTH modules all incorporate synchronous rectifiers, but does not sink current during startup, or whenever the Inhibit pin is held low.

Conditions for Prebias Holdoff

In order for the module to allow an output prebias voltage to exist (and not sink current), certain conditions must be maintained. The module holds off a prebias voltage when the Inhibit pin is held low, and whenever the output is allowed to rise under soft-start control. Power up under soft-start control occurs upon the removal of the ground signal to the Inhibit pin (with input voltage applied), or when input power is applied with Auto-Track disabled ^[2]. To further ensure that the regulator doesn't sink output current, (even with a ground signal applied to its Inhibit), the input voltage must always be greater than the applied prebias source. This condition must exist throughout the power-up sequence ^[3].

The soft-start period is complete when the output begins rising above the prebias voltage. Once it is complete the module functions as normal, and sinks current if a voltage higher than the nominal regulation value is applied to its output.

Note: If a prebias condition is not present, the soft-start period is complete when the output voltage has risen to either the set-point voltage, or the voltage applied at the module's Track control pin, whichever is lowest to its output.

Prebias Demonstration Circuit

Figure 16 shows the startup waveforms for the demonstration circuit shown in Figure 17. The initial rise in V_{O2} is the prebias voltage, which is passed from the VCCIO to the V_{CORE} voltage rail through the ASIC. Note that the output current from the PTH12010L module (I_{O2}) is negligible until its output voltage rises above the applied prebias.

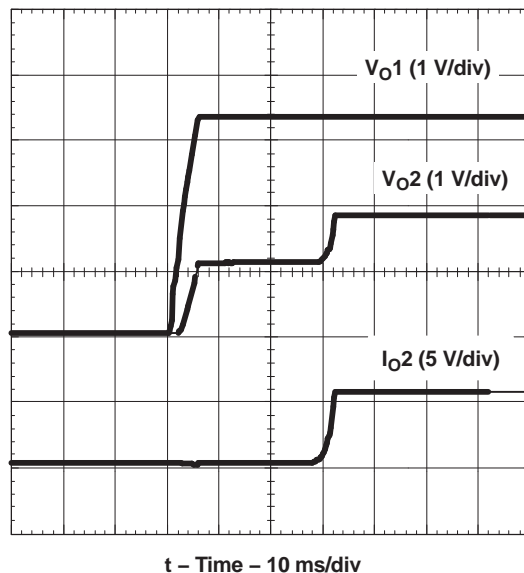

Figure 16. Prebias Startup Waveforms

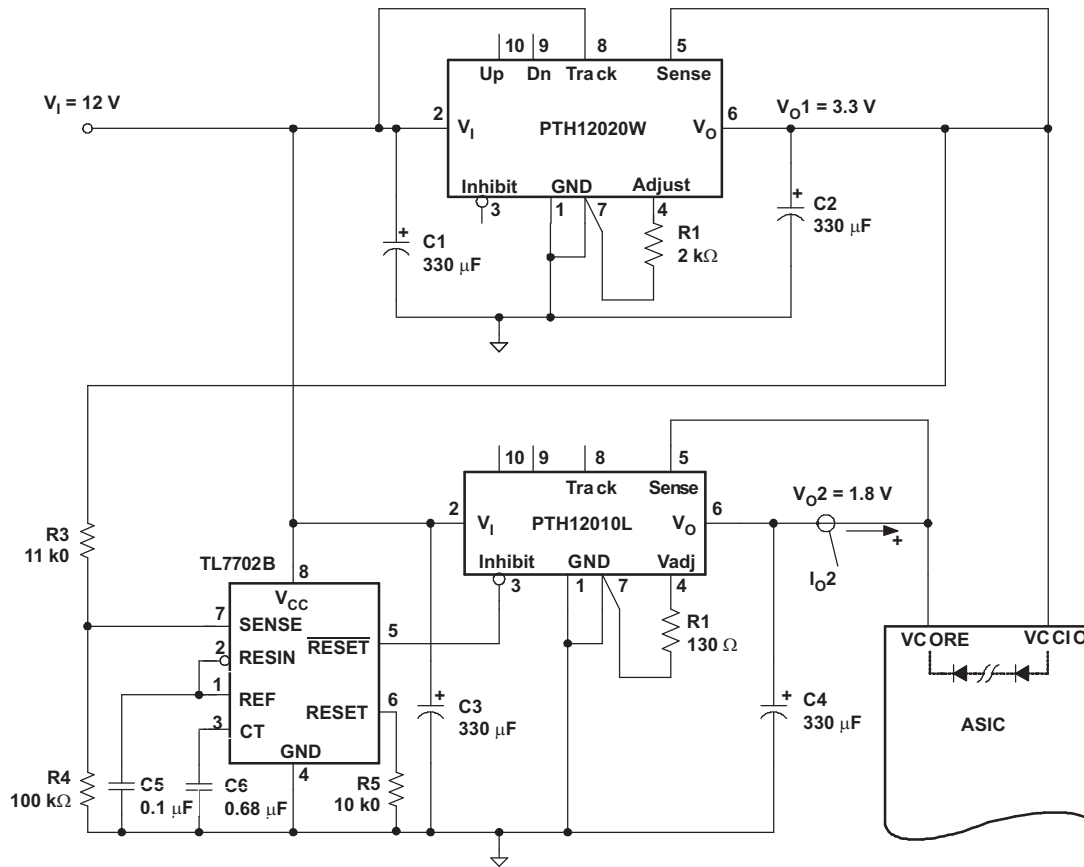

Figure 17. Application Circuit Demonstrating Prebias Startup

Notes:

1. Output prebias holdoff is an inherent feature to all PTH120x0L and PTV120x0W/L modules. It has now been incorporated into all modules (including W-suffix modules with part numbers of the form PTH120x0W), with a production lot date code of 0423 or later.
2. The prebias start-up feature is not compatible with Auto-Track. If the rise in the output is limited by the voltage applied to the Track control pin, the output sinks current during the period that the track control voltage is below that of the back-feeding source. For this reason, it is recommended that Auto-Track be disabled when not being used. This is accomplished by connecting the Track pin to the input voltage, V_1 . This raises the Track pin voltage well above the set-point voltage prior to the module's start up, thereby, defeating the Auto-Track feature.
3. To further ensure that the regulator's output does not sink current when power is first applied (even with a ground signal applied to the Inhibit control pin), the input voltage must always be greater than the applied prebias source. This condition must exist *throughout* the power-up sequence of the power system.

Overcurrent Protection

For protection against load faults, all modules incorporate output overcurrent protection. Applying a load that exceeds the regulator's overcurrent threshold causes the regulated output to shut down. Following shutdown, a module periodically attempts to recover by initiating a soft-start power-up. This is described as a *hiccup* mode of operation, whereby, the module continues in a cycle of successive shutdown and power up until the load fault is removed. During this period, the average current flowing into the fault is significantly reduced. Once the fault is removed, the module automatically recovers and returns to normal operation.

Overtemperature Protection (OTP)

The PTH12020, PTV12020, and PTH12030 products have overtemperature protection. These products have an on-board temperature sensor that protects the module's internal circuitry against excessively high temperatures. A rise in the internal temperature may be the result of a drop in airflow, or a high ambient temperature. If the internal temperature exceeds the OTP threshold, the module's Inhibit control is internally pulled low. This turns the output off. The output voltage drops as the external output capacitors are discharged by the load circuit. The recovery is automatic, and begins with a soft-start power up. It occurs when the sensed temperature decreases by about 10°C below the trip point.

Note: The overtemperature protection is a last resort mechanism to prevent thermal stress to the regulator. Operation at or close to the thermal shutdown temperature is not recommended and will reduce the long-term reliability of the module. Always operate the regulator within the specified Safe Operating Area (SOA) limits for the worst-case conditions of ambient temperature and airflow.

TAPE AND REEL SPECIFICATION

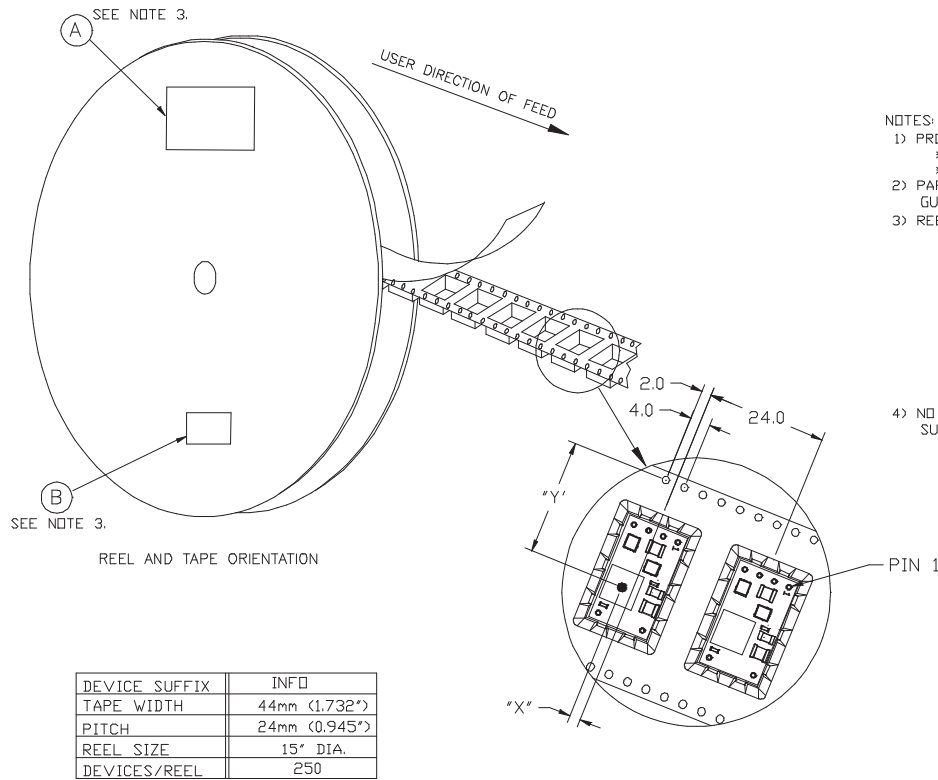

NOTES:

- 1) PROCESS IN ACCORDANCE WITH EIA-481-2
 - * TAPE LEADER DIMENSION 15.30" MIN.
 - * TAPE TRAILER DIMENSION 6.30" MIN.
- 2) PARTS SHOULD BE PACKAGED IN ACCORDANCE WITH ESD GUIDELINES IN EIA-541.
- 3) REEL LABEL: *A*- *TI PART NUMBER.
 * QUANTITY
 * DATE CODE
 * LOT NUMBER
 * MSL DATA
 * MADE IN
 * ASSY SITE ORIGIN
 * COUNTRY OF ORIGIN
 * SUPPLIER
- *B*- ANTI-STATIC CAUTION LABEL
- 4) NO REQUIREMENT FOR TAPE DIRECTION OF FEED FROM SUPPLIER REEL.

PTXXXX5X	"X"	"Y"
PTH03050/05050	-2.2mm	23.2mm
PTH04050A	2.1mm	18.7mm
PTH04050C	-1.9mm	18.7mm
PTH12050	-1.4mm	22.7mm

TRAY SPECIFICATION

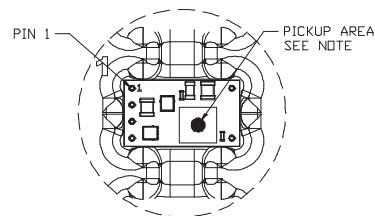
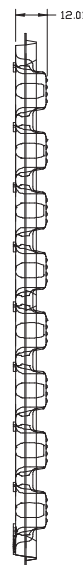
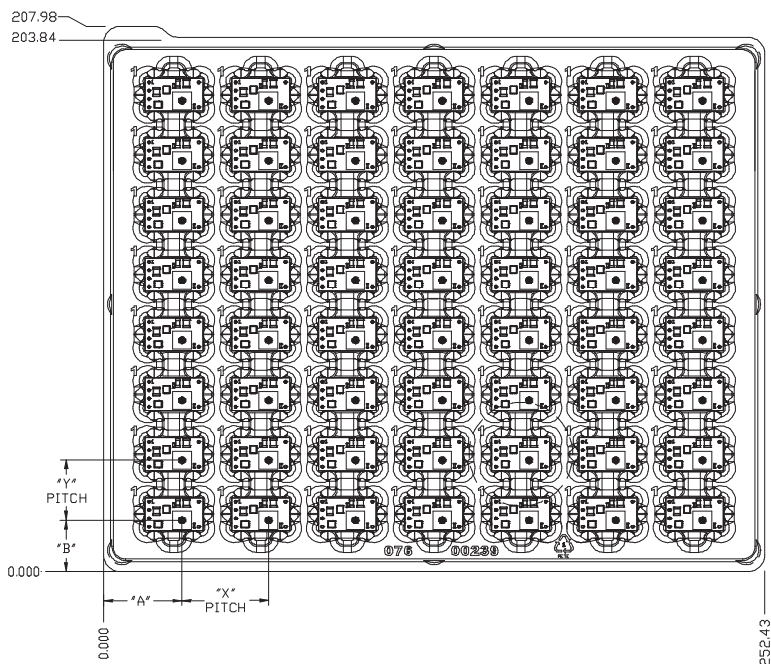

NOTE: THE INDUCTOR IS USED TO PICK AND PLACE THE MODULE. IT'S LOCATION MAY VARY FROM PACKAGE STYLE, SEE PRODUCT TABLE

PTXXXXX	"A"	"B"	"X"	"Y"
PTH03050/05050	29.90	19.62	33.12	22.86
PTH12050	29.35	20.39		
PTN04050A	25.29	23.88		
PTN04050C	25.32	19.88		

ALL DIMENSIONS ARE IN MILLIMETER.

DEVICES/TRAY	56
--------------	----

PACKAGING INFORMATION

Orderable Device	Status (1)	Package Type	Package Drawing	Pins	Package Qty	Eco Plan (2)	Lead/Ball Finish (6)	MSL Peak Temp (3)	Op Temp (°C)	Device Marking (4/5)	Samples
PTH12050LAH	ACTIVE	Through-Hole Module	EUU	6	56	RoHS Exempt & non-Green	SN	N / A for Pkg Type	-40 to 85		Samples
PTH12050LAST	ACTIVE	Surface Mount Module	EUV	6	250	RoHS (In Work) & non-Green	SNPB	Level-1-235C-UNLIM/ Level-3-260C-168HRS	-40 to 85		Samples
PTH12050LAZ	ACTIVE	Surface Mount Module	EUV	6	56	RoHS (In Work) & non-Green	SNAGCU	Level-3-260C-168 HR	-40 to 85		Samples
PTH12050LAZT	ACTIVE	Surface Mount Module	EUV	6	250	RoHS (In Work) & non-Green	SNAGCU	Level-3-260C-168 HR	-40 to 85		Samples
PTH12050WAD	ACTIVE	Through-Hole Module	EUU	6	56	RoHS Exempt & non-Green	SN	Level-1-235C-UNLIM/ Level-3-260C-168HRS	-40 to 85		Samples
PTH12050WAH	ACTIVE	Through-Hole Module	EUU	6	56	RoHS Exempt & non-Green	SN	Level-1-235C-UNLIM/ Level-3-260C-168HRS	-40 to 85		Samples
PTH12050WAS	ACTIVE	Surface Mount Module	EUV	6	56	RoHS (In Work) & non-Green	SNPB	Level-1-235C-UNLIM/ Level-3-260C-168HRS	-40 to 85		Samples
PTH12050WAST	ACTIVE	Surface Mount Module	EUV	6	250	RoHS (In Work) & non-Green	SNPB	Level-1-235C-UNLIM/ Level-3-260C-168HRS	-40 to 85		Samples
PTH12050WAZ	ACTIVE	Surface Mount Module	EUV	6	56	RoHS (In Work) & non-Green	SNAGCU	Level-3-260C-168 HR	-40 to 85		Samples
PTH12050WAZT	ACTIVE	Surface Mount Module	EUV	6	250	RoHS (In Work) & non-Green	SNAGCU	Level-3-260C-168 HR	-40 to 85		Samples

(1) The marketing status values are defined as follows:

ACTIVE: Product device recommended for new designs.

LIFEBUY: TI has announced that the device will be discontinued, and a lifetime-buy period is in effect.

NRND: Not recommended for new designs. Device is in production to support existing customers, but TI does not recommend using this part in a new design.

PREVIEW: Device has been announced but is not in production. Samples may or may not be available.

OBSOLETE: TI has discontinued the production of the device.

(2) **RoHS:** TI defines "RoHS" to mean semiconductor products that are compliant with the current EU RoHS requirements for all 10 RoHS substances, including the requirement that RoHS substance do not exceed 0.1% by weight in homogeneous materials. Where designed to be soldered at high temperatures, "RoHS" products are suitable for use in specified lead-free processes. TI may reference these types of products as "Pb-Free".

RoHS Exempt: TI defines "RoHS Exempt" to mean products that contain lead but are compliant with EU RoHS pursuant to a specific EU RoHS exemption.

Green: TI defines "Green" to mean the content of Chlorine (Cl) and Bromine (Br) based flame retardants meet JS709B low halogen requirements of <=1000ppm threshold. Antimony trioxide based flame retardants must also meet the <=1000ppm threshold requirement.

(3) MSL, Peak Temp. - The Moisture Sensitivity Level rating according to the JEDEC industry standard classifications, and peak solder temperature.

(4) There may be additional marking, which relates to the logo, the lot trace code information, or the environmental category on the device.

(5) Multiple Device Markings will be inside parentheses. Only one Device Marking contained in parentheses and separated by a "~" will appear on a device. If a line is indented then it is a continuation of the previous line and the two combined represent the entire Device Marking for that device.

(6) Lead/Ball Finish - Orderable Devices may have multiple material finish options. Finish options are separated by a vertical ruled line. Lead/Ball Finish values may wrap to two lines if the finish value exceeds the maximum column width.

Important Information and Disclaimer:The information provided on this page represents TI's knowledge and belief as of the date that it is provided. TI bases its knowledge and belief on information provided by third parties, and makes no representation or warranty as to the accuracy of such information. Efforts are underway to better integrate information from third parties. TI has taken and continues to take reasonable steps to provide representative and accurate information but may not have conducted destructive testing or chemical analysis on incoming materials and chemicals. TI and TI suppliers consider certain information to be proprietary, and thus CAS numbers and other limited information may not be available for release.

In no event shall TI's liability arising out of such information exceed the total purchase price of the TI part(s) at issue in this document sold by TI to Customer on an annual basis.

EUU (R-PDSS-T6)

DOUBLE SIDED MODULE

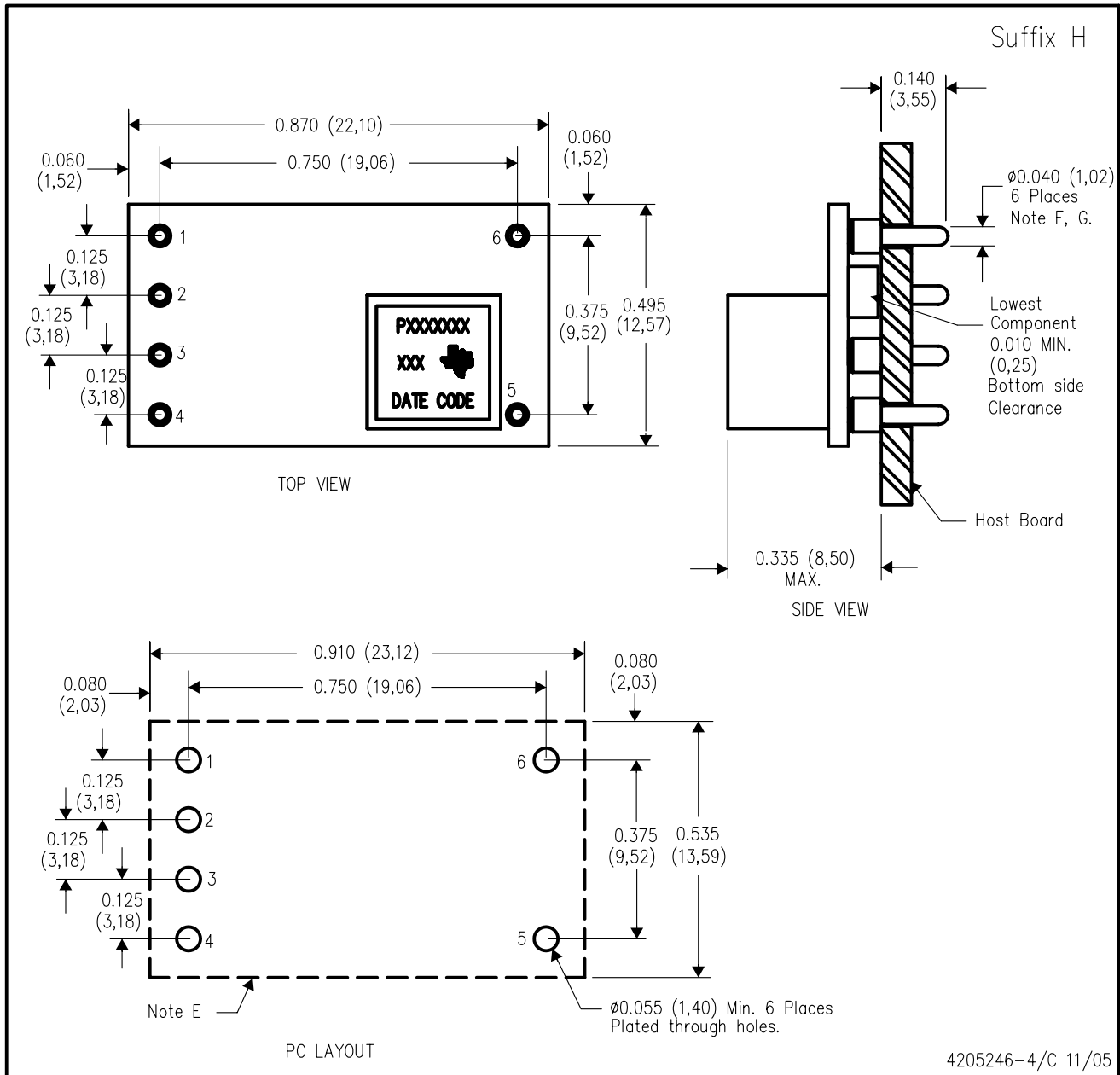

- NOTES:
- A. All linear dimensions are in inches (mm).
 - B. This drawing is subject to change without notice.
 - C. 2 place decimals are ± 0.030 ($\pm 0,76\text{mm}$).
 - D. 3 place decimals are ± 0.010 ($\pm 0,25\text{mm}$).
 - E. Recommended keep out area for user components.

- F. Pins are 0.040" (1,02) diameter with 0.070" (1,78) diameter standoff shoulder.
- G. All pins: Material - Copper Alloy
Finish - Tin (100%) over Nickel plate

EUV (R-PDSS-B6)

DOUBLE SIDED MODULE

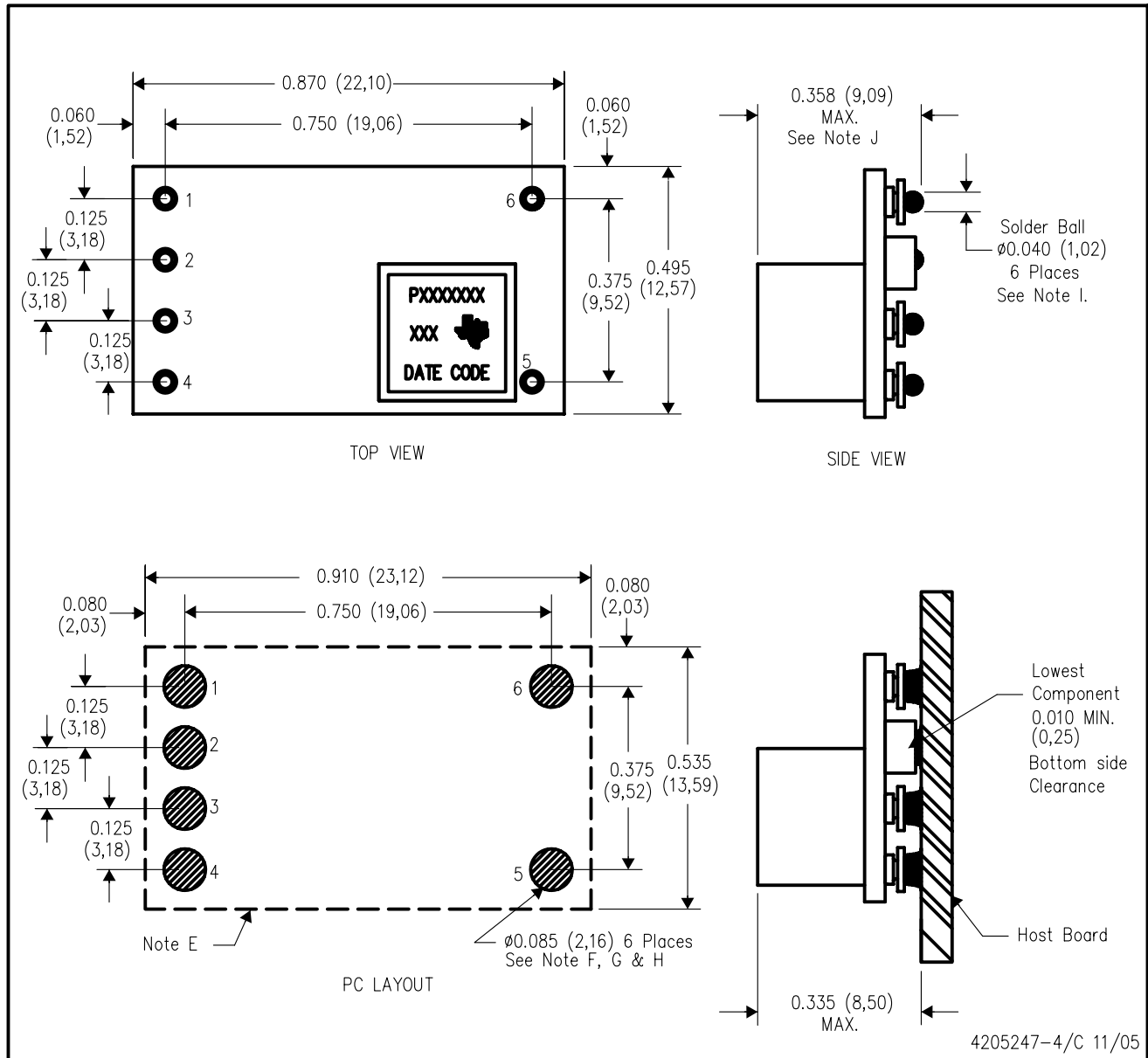

- NOTES:
- A. All linear dimensions are in inches (mm).
 - B. This drawing is subject to change without notice.
 - C. 2 place decimals are ± 0.030 ($\pm 0,76$ mm).
 - D. 3 place decimals are ± 0.010 ($\pm 0,25$ mm).
 - E. Recommended keep out area for user components.
 - F. Power pin connection should utilize two or more vias to the interior power plane of 0.025 (0,63) I.D. per input, ground and output pin (or the electrical equivalent).

- G. Paste screen opening: 0.080 (2,03) to 0.085 (2,16).
Paste screen thickness: 0.006 (0,15).
- H. Pad type: Solder mask defined.
- I. All pins: Material – Copper Alloy
Finish – Tin (100%) over Nickel plate
Solder Ball – See product data sheet.
- J. Dimension prior to reflow solder.

IMPORTANT NOTICE AND DISCLAIMER

TI PROVIDES TECHNICAL AND RELIABILITY DATA (INCLUDING DATASHEETS), DESIGN RESOURCES (INCLUDING REFERENCE DESIGNS), APPLICATION OR OTHER DESIGN ADVICE, WEB TOOLS, SAFETY INFORMATION, AND OTHER RESOURCES "AS IS" AND WITH ALL FAULTS, AND DISCLAIMS ALL WARRANTIES, EXPRESS AND IMPLIED, INCLUDING WITHOUT LIMITATION ANY IMPLIED WARRANTIES OF MERCHANTABILITY, FITNESS FOR A PARTICULAR PURPOSE OR NON-INFRINGEMENT OF THIRD PARTY INTELLECTUAL PROPERTY RIGHTS.

These resources are intended for skilled developers designing with TI products. You are solely responsible for (1) selecting the appropriate TI products for your application, (2) designing, validating and testing your application, and (3) ensuring your application meets applicable standards, and any other safety, security, or other requirements. These resources are subject to change without notice. TI grants you permission to use these resources only for development of an application that uses the TI products described in the resource. Other reproduction and display of these resources is prohibited. No license is granted to any other TI intellectual property right or to any third party intellectual property right. TI disclaims responsibility for, and you will fully indemnify TI and its representatives against, any claims, damages, costs, losses, and liabilities arising out of your use of these resources.

TI's products are provided subject to TI's Terms of Sale (www.ti.com/legal/termsofsale.html) or other applicable terms available either on ti.com or provided in conjunction with such TI products. TI's provision of these resources does not expand or otherwise alter TI's applicable warranties or warranty disclaimers for TI products.

Mailing Address: Texas Instruments, Post Office Box 655303, Dallas, Texas 75265
Copyright © 2018, Texas Instruments Incorporated

Looking for pricing, stock, or lifecycle information?

Click below to explore more details on WIN SOURCE:

 [View PTH12050LAZT on WIN SOURCE](#)

 [Texas Instruments](#) Information

Optimize Your Supply Chain with WIN SOURCE Solutions

-  Global Sourcing Solution
-  Obsolete Management
-  Cost Control Management
-  Shortage Management
-  Alternative Solution
-  Excess Inventory Management