

Trimmer Potentiometers



SMD Sealed Type Multi-turn Type PVG5/PV01 Series

PVG5 Series

■ Features

1. High resolution resulting from 11-turns design enables precise adjustment.
2. 5mm miniature size lead a high density PCB mounting.
3. Compatible with VPS reflow soldering method.
4. Compatible with ultrasonic cleaning.
5. Clutch mechanism prevents excessive wiper rotation.

■ Applications

1. Measuring instruments
2. sensors
3. CPUs
4. Industrial machines

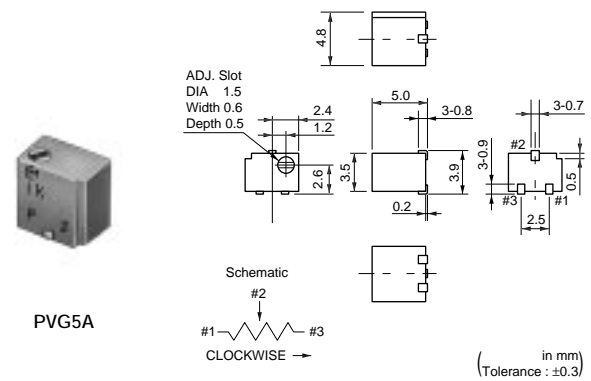

PVG5A

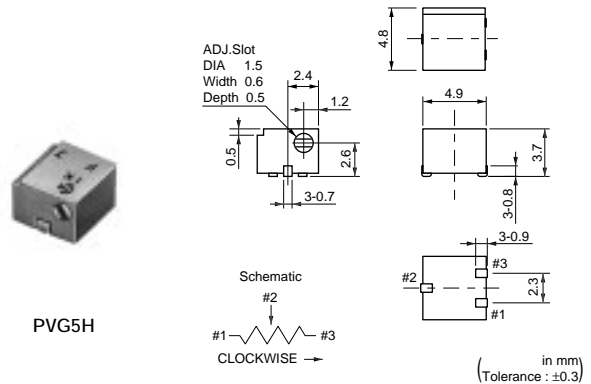

PVG5H

6

Part Number	Power Rating (W)	Soldering Method	Number of Turns (Effective Rotation Angle)	Total Resistance Value	TCR (ppm/°C)
PVG5□100A01	0.25(70°C)	Reflow	11	10ohm ±10%	±200
PVG5□200A01	0.25(70°C)	Reflow	11	20ohm ±10%	±200
PVG5□500A01	0.25(70°C)	Reflow	11	50ohm ±10%	±200
PVG5□101A01	0.25(70°C)	Reflow	11	100ohm ±10%	±200
PVG5□201A01	0.25(70°C)	Reflow	11	200ohm ±10%	±100
PVG5□501A01	0.25(70°C)	Reflow	11	500ohm ±10%	±100
PVG5□102A01	0.25(70°C)	Reflow	11	1k ohm ±10%	±100
PVG5□202A01	0.25(70°C)	Reflow	11	2k ohm ±10%	±100
PVG5□502A01	0.25(70°C)	Reflow	11	5k ohm ±10%	±100
PVG5□103A01	0.25(70°C)	Reflow	11	10k ohm ±10%	±100
PVG5□203A01	0.25(70°C)	Reflow	11	20k ohm ±10%	±100
PVG5□503A01	0.25(70°C)	Reflow	11	50k ohm ±10%	±100
PVG5□104A01	0.25(70°C)	Reflow	11	100k ohm ±10%	±100
PVG5□204A01	0.25(70°C)	Reflow	11	200k ohm ±10%	±100
PVG5□504A01	0.25(70°C)	Reflow	11	500k ohm ±10%	±100
PVG5□105A01	0.25(70°C)	Reflow	11	1M ohm ±10%	±100
PVG5□205A01	0.25(70°C)	Reflow	11	2M ohm ±10%	±100

The blank column is filled with the code of adjustment direction A (top) or H (side).

■ Construction

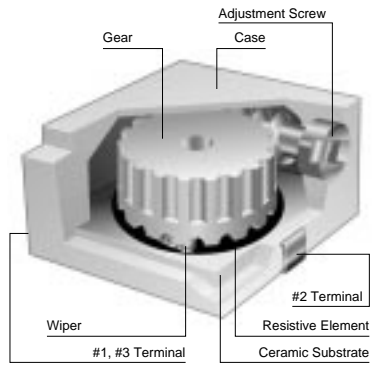

■ Standard Land Pattern

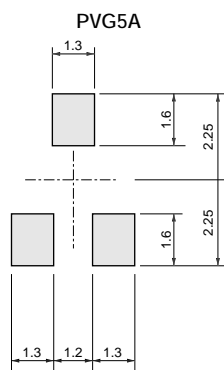

in mm
(Tolerance : ±0.1)

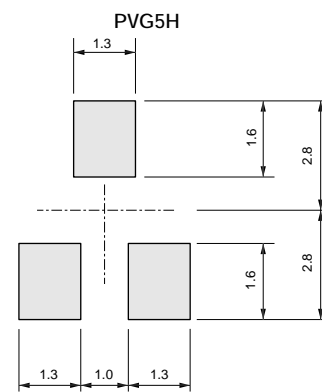

in mm
(Tolerance : ±0.1)

■ Characteristics

6

Temperature Cycle	Δ TR $\pm 2\%$ Δ V.S.S. $\pm 1\%$
Humidity	Δ TR $\pm 2\%$ IR 10Mohm min.
Vibration	Δ TR $\pm 1\%$ Δ V.S.S. $\pm 1\%$
Shock	Δ TR $\pm 1\%$ Δ V.S.S. $\pm 1\%$
Temperature Load Life	Δ TR $\pm 3\%$ or 3ohm max., whichever is greater Δ V.S.S. $\pm 1\%$
Low Temperature Exposure	Δ TR $\pm 1\%$ Δ V.S.S. $\pm 1\%$
High Temperature Exposure	Δ TR $\pm 2\%$ Δ V.S.S. $\pm 1\%$
Rotational Life (100 cycles)	Δ TR $\pm 3\%$ or 3ohm max., whichever is greater

Δ TR : Total Resistance Change
 Δ V.S.S. : Voltage Setting Stability
IR : Insulation Resistance

PV01 Series

■ Features

1. High resolution, resulting from 12-turns design enables precise adjustment.
2. Compatible with VPS reflow soldering method.
3. Small size. (6.35x6.35x4.3mm)
4. Compatible with ultrasonic cleaning.
5. Clutch mechanism prevents excessive wiper rotation.

■ Applications

1. Measuring instruments
2. Facsimile machines
3. CPUs
4. PPCs
5. Printers
6. Sensors



PV01P

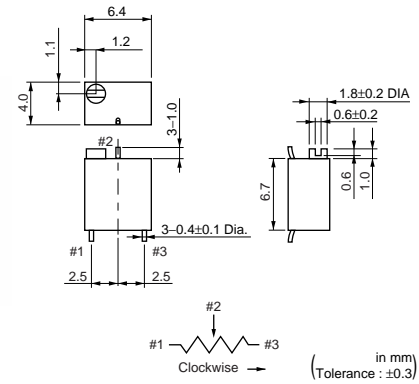

PV01W

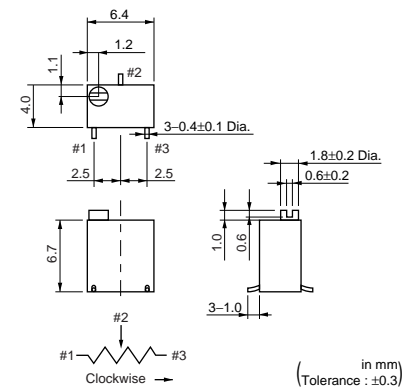

PV01X

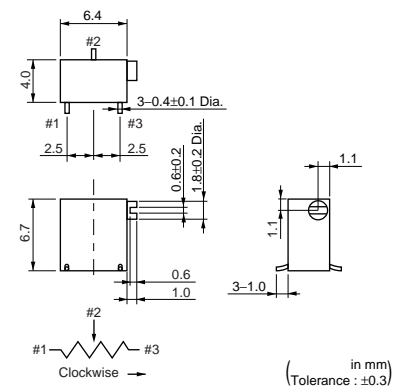

Part Number	Power Rating (W)	Soldering Method	Number of Turns (Effective Rotation Angle)	Total Resistance Value	TCR (ppm/°C)
PV01□100A01	0.25(85°C)	Reflow	12	10ohm ±10%	±100
PV01□200A01	0.25(85°C)	Reflow	12	20ohm ±10%	±100
PV01□500A01	0.25(85°C)	Reflow	12	50ohm ±10%	±100
PV01□101A01	0.25(85°C)	Reflow	12	100ohm ±10%	±100
PV01□201A01	0.25(85°C)	Reflow	12	200ohm ±10%	±100
PV01□501A01	0.25(85°C)	Reflow	12	500ohm ±10%	±100
PV01□102A01	0.25(85°C)	Reflow	12	1k ohm ±10%	±100
PV01□202A01	0.25(85°C)	Reflow	12	2k ohm ±10%	±100
PV01□502A01	0.25(85°C)	Reflow	12	5k ohm ±10%	±100
PV01□103A01	0.25(85°C)	Reflow	12	10k ohm ±10%	±100
PV01□203A01	0.25(85°C)	Reflow	12	20k ohm ±10%	±100
PV01□253A01	0.25(85°C)	Reflow	12	25k ohm ±10%	±100
PV01□503A01	0.25(85°C)	Reflow	12	50k ohm ±10%	±100
PV01□104A01	0.25(85°C)	Reflow	12	100k ohm ±10%	±100
PV01□204A01	0.25(85°C)	Reflow	12	200k ohm ±10%	±100
PV01□254A01	0.25(85°C)	Reflow	12	250k ohm ±10%	±100

Continued on the following page.

Continued from the preceding page.

Part Number	Power Rating (W)	Soldering Method	Number of Turns (Effective Rotation Angle)	Total Resistance Value	TCR (ppm/°C)
PV01□504A01	0.25(85°C)	Reflow	12	500k ohm ±10%	±100
PV01□105A01	0.25(85°C)	Reflow	12	1M ohm ±10%	±100

The blank column is filled with the code of adjustment direction P (side), W (top) or X (rear).
Magazine packaging is standard for PV01 series.

Construction

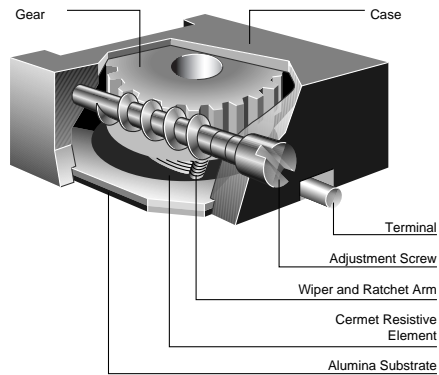

Standard Land Dimension

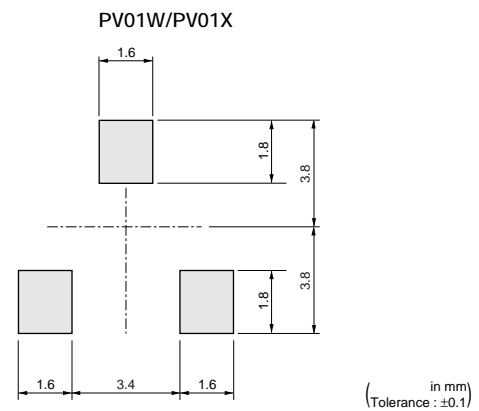
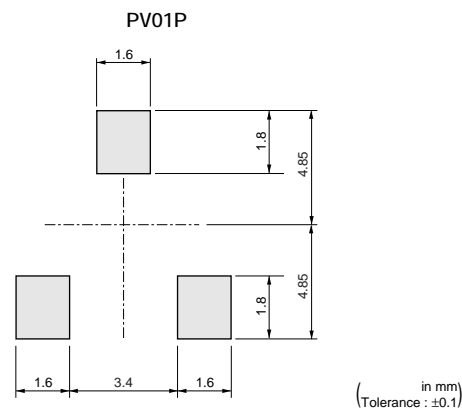

6

Characteristics

Temperature Cycle	ΔTR	±1%
	ΔV.S.S.	±1%
Humidity	ΔTR	±2%
	IR	100Mohm min.
Vibration (20G)	ΔTR	±1%
	ΔV.S.S.	±1%
Shock (100G)	ΔTR	±1%
	ΔV.S.S.	±1%
Temperature Load Life	ΔTR	±2%
	ΔV.S.S.	±1%
Low Temperature Exposure	ΔTR	±1%
	ΔV.S.S.	±1%
High Temperature Exposure	ΔTR	±2%
	ΔV.S.S.	±1%
Rotational Life (200 cycles)	ΔTR	±2%

ΔTR : Total Resistance Change
ΔV.S.S. : Voltage Setting Stability
IR : Insulation Resistance

PVG5/PV01 Series Notice

■ Notice (Operating and Storage Conditions)

1. Store that the temperature is -10 to +40deg. C and the relative humidity is 30-85%RH.
2. Do not store in or near corrosive gases.
3. Use within six months after delivery.
4. Open the package just before using.
5. Do not store under direct sunlight.
6. The trimmer potentiometer should not be used under the following environmental conditions:
If you use the trimmer potentiometer in an environment other than these listed below, please consult with Murata factory representative prior to

using.

- (1) Corrosive gaseous atmosphere.
(Ex. Chlorine gas, Hydrogen sulfide gas, Ammonia gas, Sulfuric acid gas, Nitric oxide gas, etc.)
- (2) In liquid.
(Ex. Oil, Medical liquid, Organic solvent, etc.)
- (3) Dusty/dirty atmosphere.
- (4) Direct sunlight.
- (5) Static voltage nor electric/magnetic fields.
- (6) Direct sea breeze.
- (7) Other variations of the above.

■ Notice (Rating)

1. When using with partial load (rheostat), minimize the power depend on the resistance value.
2. The maximum input voltage to a trimmer potentiometer should not exceed $(P \cdot R)^{1/2}$ or the maximum operating voltage, whichever is smaller.
3. The maximum input current to a trimmer potentiometer should not exceed $(P/R)^{1/2}$ or the allowable wiper current, whichever is smaller.

■ Notice (Soldering and Mounting)

1. Soldering

(1) Standard soldering condition

(a) Reflow and flow soldering :

Refer to the standard temperature profile.

(b) Soldering iron :

>Temperature of tip 260 deg.C max.

>Soldering time 3sec. max.

>Diameter 2mm dia. max.

>Wattage of iron 30W max.

Before using other soldering conditions than those listed above, please consult with Murata factory representative prior to using. If the soldering conditions are not suitable, e. g., excessive time and/or excessive temperature, the trimmer capacitor may deviate from the specified characteristics.

- (2) Can not be soldered using the flow soldering method. If you use the flow soldering method, the trimmer potentiometer may not function.
- (3) The soldering iron should not come in contact with the case of the trimmer potentiometer. If such contact does occur, the trimmer potentiometer may be damaged.
- (4) Insufficient amounts of solder can lead to insufficient soldering strength on PCB.
Excessive amounts of solder may cause the bridging between the terminals.

2. Mounting

- (1) Use our standard land dimension. Excessive land area causes displacement due to effect of the

surface tension of the solder. Insufficient land area leads to insufficient soldering strength of the chip.

- (2) Do not apply excessive force (preferable 9.8N (Ref.; 1kgf) max.), when the trimmer potentiometer is mounted to the PCB.
- (3) Do not warp and/or bend PC board to prevent trimmer potentiometer from breakage.
- (4) In chip placers, the recommended size of the cylindrical pick-up nozzle should be outer dimension 4.0mm dia. and inner dimension 2.0mm dia..

3. Cleaning

- (1) Isopropyl-alcohol and Ethyl-alcohol are applicable solvent for cleaning. If you use any other types of solvents, please consult with Murata factory representative prior to using.

- (2) The total cleaning time by cold dipping, vapor and ultrasonic washing (conditions as below) method shall be less than 3 minutes.

- (3) For ultra-sonic cleaning, the available condition is as follows.

>Power : 600W (67liter) max.

>Frequency : 28kHz

>Temperature : Ambient temperature

Due to the ultra-sonic cleaning equipment peculiar self resonance point and the cleaning compatibility usually depends on the jig construction and/or the cleaning condition such as the depth of immersion, please check the

PVG5/PV01 Series Notice

☒ Continued from the preceding page.

cleaning equipment to determine the suitable conditions.

If the trimmer potentiometer is cleaned by other

conditions, the trimmer potentiometer may be damaged.

■ Reflow Soldering Standard Profile

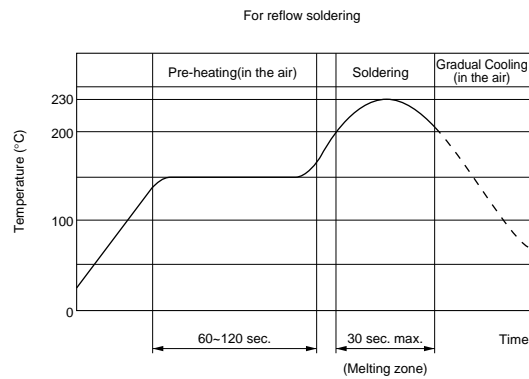

■ Notice (Handling)

1. Use suitable screwdrivers that fit comfortably in driver slot. We recommend the below screwdrivers.

* Recommended screwdriver for manual adjustment

<PVG5 series>

VESSEL MFG. : NO. 9000-1.3x30

(Murata P/N : KMDR130)

<PV01 series>

VESSEL MFG. : NO. 9000-1.8x30

(Murata P/N : KMDR110)

We can supply above screwdrivers.

If you place order, please nominate Murata P/N.

2. Don't apply more than 9.8N (Ref.; 1kgf) of twist and stress after mounted onto PCB to prevent contact intermittence. If excessive force is applied, the trimmer potentiometer may not function.

3. When adjusting with a screwdriver, do not apply excessive force (preferable 4.9N (Ref; 500gf) max.)

4. When using a lock paint to fix slot position, please use adhesive resin without chlorine or sulfur (Three-bond "1401series").

6

■ Notice (Other)

1. Please make sure that your product has been evaluated and confirmed against your specifications when our product is mounted to your product.

2. Murata cannot guarantee trimmer potentiometer integrity when used under conditions other than those specified in this document.

SMD Sealed Type/Lead Sealed Type Specifications and Test Methods

The following describes trimmer potentiometer testing conducted by Murata Manufacturing Co., Ltd. in accordance with MIL-R-22097 (Military specification for variable resistors, non-wirewound) and MIL-STD-202 (Test methods for electronic and electrical component parts).

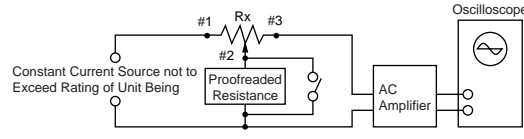
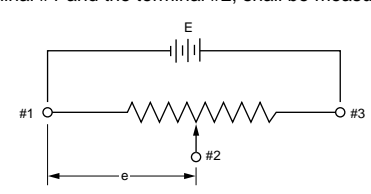
No.	Item	Test Methods																				
1	Total Resistance	<p>Measure total resistance between the resistance element and terminals (#1 and #3) with the contact arm positioned against a stop. The positioning of the contact arm and terminal shall be the same for subsequent total resistance measurements on the same device. Use the test voltage specified in Table-1 for total resistance measurements. This voltage shall be used for all subsequent total resistance measurements.</p> <table border="1"> <thead> <tr> <th>Total resistance, Nominal (ohm)</th> <th>Maximum Test Voltage (V)</th> </tr> </thead> <tbody> <tr> <td>$10 \leq R \leq 100$</td> <td>1.0</td> </tr> <tr> <td>$100 < R \leq 1k$</td> <td>3.0</td> </tr> <tr> <td>$1k < R \leq 10k$</td> <td>10.0</td> </tr> <tr> <td>$10k < R \leq 100k$</td> <td>30.0</td> </tr> <tr> <td>$100k < R$</td> <td>100.0</td> </tr> </tbody> </table> <p>Table-1 Total resistance test voltage</p>	Total resistance, Nominal (ohm)	Maximum Test Voltage (V)	$10 \leq R \leq 100$	1.0	$100 < R \leq 1k$	3.0	$1k < R \leq 10k$	10.0	$10k < R \leq 100k$	30.0	$100k < R$	100.0								
Total resistance, Nominal (ohm)	Maximum Test Voltage (V)																					
$10 \leq R \leq 100$	1.0																					
$100 < R \leq 1k$	3.0																					
$1k < R \leq 10k$	10.0																					
$10k < R \leq 100k$	30.0																					
$100k < R$	100.0																					
2	Residual Resistance	<p>Position the contact arm at the extreme counterclockwise limit of mechanical travel and measure the resistance between the contact arm and the corresponding end terminal. Then, position the contact arm at the extreme clockwise limit of mechanical travel and measure the resistance between the contact arm and the corresponding end terminal. During this test, take suitable precautions to ensure that the rated current of the resistance element is not exceeded.</p>																				
3	Contact Resistance Variation	<p>Contact resistance variation shall be measured with the measuring circuit shown in Figure-1, or its equivalent. The adjustment rotor (screw) shall be rotated in both directions through 90% of the actual effective-electrical rotational angle (number of turns) for a total of 6 cycles. Only the last 3 cycles shall count in determining whether or not a contact resistance variation is observed at least twice in the same location, exclusive of the roll-on or roll-off points where the contact arm moves from the termination, on or off, the resistance element. The rate of rotation of the adjustment rotor (screw) shall be such that the adjustment rotor (screw) completes 1 cycle for 5 seconds minimum to 2 minutes maximum. The test current used shall follow the value given in Table-2 unless otherwise limited by power rating.</p> <table border="1"> <thead> <tr> <th>Standard total resistance R (ohm)</th> <th>Test current</th> </tr> </thead> <tbody> <tr> <td>$R \leq 100$</td> <td>20mA</td> </tr> <tr> <td>$100 < R < 500$</td> <td>10mA</td> </tr> <tr> <td>$500 \leq R < 1k$</td> <td>4mA</td> </tr> <tr> <td>$1k \leq R < 2k$</td> <td>2mA</td> </tr> <tr> <td>$2k \leq R < 50k$</td> <td>1mA</td> </tr> <tr> <td>$50k \leq R < 200k$</td> <td>200μA</td> </tr> <tr> <td>$200k \leq R < 1M$</td> <td>100μA</td> </tr> <tr> <td>$1M \leq R < 2M$</td> <td>50μA</td> </tr> <tr> <td>$2M \leq R$</td> <td>30μA</td> </tr> </tbody> </table> <p>Table-2 Test current for CRV</p>  <p>Rx : Trimmer Potentiometer Oscilloscope bandwidth : 100Hz to 50kHz</p> <p>Figure-1 CRV measuring circuit</p>	Standard total resistance R (ohm)	Test current	$R \leq 100$	20mA	$100 < R < 500$	10mA	$500 \leq R < 1k$	4mA	$1k \leq R < 2k$	2mA	$2k \leq R < 50k$	1mA	$50k \leq R < 200k$	200μA	$200k \leq R < 1M$	100μA	$1M \leq R < 2M$	50μA	$2M \leq R$	30μA
Standard total resistance R (ohm)	Test current																					
$R \leq 100$	20mA																					
$100 < R < 500$	10mA																					
$500 \leq R < 1k$	4mA																					
$1k \leq R < 2k$	2mA																					
$2k \leq R < 50k$	1mA																					
$50k \leq R < 200k$	200μA																					
$200k \leq R < 1M$	100μA																					
$1M \leq R < 2M$	50μA																					
$2M \leq R$	30μA																					
4	Temperature Coefficient of Resistance	<p>The trimmer potentiometer shall be subjected to the following each temperature (see Table-3) for 30-45 minutes. Temperature coefficient of resistance shall be applied to the following formula.</p> $TCR = \frac{R_2 - R_1}{R_1 (T_2 - T_1)} \times 10^6 \text{ (ppm/}^\circ\text{C)}$ <p>T₁ : Reference temperature in degrees celsius T₂ : Test temperature in degrees celsius R₁ : Resistance at reference temperature ohm R₂ : Resistance at test temperature in ohm</p> <table border="1"> <thead> <tr> <th>Sequence</th> <th>1*</th> <th>2</th> <th>3</th> <th>4*</th> <th>5</th> <th>6</th> </tr> </thead> <tbody> <tr> <td>Temperature(°C)</td> <td>+25</td> <td>-15</td> <td>Min. operating temperature</td> <td>+25</td> <td>+65</td> <td>Max. operating temperature</td> </tr> </tbody> </table> <p>Note) * : Reference temperature</p> <p>Table-3 Test temperatures</p>	Sequence	1*	2	3	4*	5	6	Temperature(°C)	+25	-15	Min. operating temperature	+25	+65	Max. operating temperature						
Sequence	1*	2	3	4*	5	6																
Temperature(°C)	+25	-15	Min. operating temperature	+25	+65	Max. operating temperature																
5	Voltage Setting Stability	<p>The wiper shall be set at approximately 40% of the actual effective-electrical rotational angle (number of turns). An adequate DC test potential shall be applied between the terminal #1 and the terminal #3. The voltage between the terminal #1 and the terminal #3, and the voltage between the terminal #1 and the terminal #2, shall be measured and applied to the following formula.</p> $\text{Voltage setting stability} = \left(\frac{e'}{E} - \frac{e}{E} \right) \times 100 \text{ (\%)}$ <p>e : Before test (The voltage between the terminal #1 and the terminal #2) e' : After test (The voltage between the terminal #1 and the terminal #2) E : The voltage between the terminal #1 and the terminal #3</p>  <p>Figure-2</p>																				

Continued on the following page. 

SMD Sealed Type/Lead Sealed Type Specifications and Test Methods

Continued from the preceding page.

No.	Item	Test Methods																	
6	Temperature Cycle	<p>The trimmer potentiometer shall be subjected to Table-4 temperature for 5 cycles. The trimmer potentiometer shall be removed from the chamber, and maintained at a temperature of 25±5°C for 1~2 hours.</p> <table border="1" style="width: 100%; border-collapse: collapse; margin: 10px 0;"> <thead> <tr style="background-color: #e0e0e0;"> <th style="width: 15%;">Sequence</th> <th style="width: 15%;">1</th> <th style="width: 15%;">2</th> <th style="width: 15%;">3</th> <th style="width: 15%;">4</th> </tr> </thead> <tbody> <tr> <td>Temp. (°C)</td> <td>PV□□ series PV22 series PVF2 series</td> <td>-55±3</td> <td>+25±2</td> <td>+125±3 +150±3 +60±3</td> <td>+25±2</td> </tr> <tr> <td>Time (min.)</td> <td></td> <td>30</td> <td>5 max.</td> <td>30</td> <td>5 max.</td> </tr> </tbody> </table> <p style="text-align: center; margin: 0;">Table-4 One cycle of temperature cycle.</p>	Sequence	1	2	3	4	Temp. (°C)	PV□□ series PV22 series PVF2 series	-55±3	+25±2	+125±3 +150±3 +60±3	+25±2	Time (min.)		30	5 max.	30	5 max.
Sequence	1	2	3	4															
Temp. (°C)	PV□□ series PV22 series PVF2 series	-55±3	+25±2	+125±3 +150±3 +60±3	+25±2														
Time (min.)		30	5 max.	30	5 max.														
7	Humidity	<p>1) PVC6, PV12, PV32, PV34 PVM4A□□□B01series The trimmer potentiometer shall be placed in a chamber at a temperature of 40±2°C and a humidity of 90~95% without loading for 250±8 hours. The trimmer potentiometer shall be removed from the chamber, and maintained at a temperature of 25±5°C for 5±1/6 hours.</p> <p>2) PVF2series The trimmer potentiometer shall be placed in a chamber at 60±2°C and 90~95% without loading for 1000±12 hours. The trimmer potentiometer shall be removed from the chamber, and maintained at a temperature of 25±5°C for 5±1/6 hours</p> <p>2) PVG3, PVG5, PV01, PV22, PV23, PV36, PV37series The trimmer potentiometer shall be subjected Figure-3 the programmed humidity environment for 10 cycle. The trimmer potentiometer shall be removed from the chamber, and maintained at a temperature of 25±5°C for 5±1/2 hours.</p> <div style="text-align: right; font-size: small; margin-bottom: 5px;">MIL-STD-202 METHOD 106</div> <p style="text-align: center; margin: 10px 0;">Figure-3</p>																	
8	Vibration	<p>1) PV□□ series The trimmer potentiometer shall be vibrated throughout the frequency range at the 20G level. A complete frequency range, 10Hz to 2000Hz and back, shall be made within 15 minutes for a total of 4 sweeps in each of the three axis direction for a total of 12 sweeps.</p> <p>2) PVF2 series The trimmer potentiometer shall be subjected to vibration at 0.3 inch amplitude. The frequency shall be varied uniformly between the approximate limits of 10 Hz and 55Hz. This motion shall be applied for period of 2 hours in each of 3 mutually perpendicular direction (total of 6 hours).</p>																	
9	Shock	<p>1) PV□□ series The trimmer potentiometer shall be shocked at the 100G (50G for PV22 and PV23series) level and shall be subjected to 4 shocks in each of the three axis direction for a total of 12 shocks.</p> <p>2) PVM4A□□□B01series The trimmer potentiometer shall be shocked at the 100G level and shall be subjected to 3 shocks in each of the six axis direction for a total of 18 shocks.</p>																	
10	Temperature Road Life	<p>Full rated continuous working voltage not exceeding the maximum rated voltage shall be applied intermittently between the terminal #1 and the terminal #3 of the trimmer potentiometer, 1.5 hours on and 0.5 hours off, for a total of 1000±12 hours, at a temperature of 70±2°C (85±2°C for PV01 and PV37series, 50±2°C for PVF2series). The trimmer potentiometer shall be removed from the chamber, and maintained at a temperature of 25±5°C for 1 to 2 hours.</p>																	
11	High Temperature Exposure (Except for PVF2)	<p>The trimmer potentiometer shall be placed in a chamber at a temperature of 125±3°C (150±3°C for PV12series) 250±8 hours without loading. The trimmer potentiometer shall be removed from the chamber, and maintained at a temperature of 25±5°C for 1 to 2 hours.</p>																	
12	Low Temperature Exposure (Except for PVF2 and PVM4A□□□B01)	<p>The trimmer potentiometer shall be placed in a chamber at a temperature of -55±3°C for 1 hours without loading. Full rated continuous working voltage not exceeding the maximum rated voltage shall be applied for 45 minutes. The trimmer potentiometer shall be removed from the chamber, and maintained at a temperature of 25±5°C for approximately 24 hours.</p>																	

Continued on the following page.

SMD Sealed Type/Lead Sealed Type Specifications and Test Methods

Continued from the preceding page.

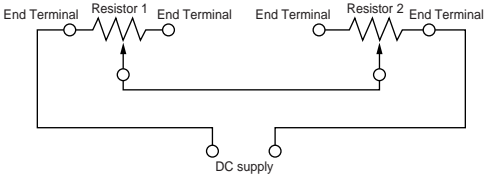
No.	Item	Test Methods
13	Low Temperature Operation (Only for PVF2 and PVM4□□□B01)	The trimmer potentiometer shall be placed in a chamber at a temperature of $-25\pm 3^{\circ}\text{C}$ ($-55\pm 3^{\circ}\text{C}$ for PVM4□□□B01series) 48±4 hours without loading. The trimmer potentiometer shall be removed from the chamber, and maintained at a temperature of $25\pm 5^{\circ}\text{C}$ for 5±1/6 hours
14	Rotational Life	<p>1) PV□□ series Full rated continuous working voltage not exceeding the maximum rated voltage shall be applied with the circuit shown in the figure. The adjustment rotor (screw) shall be continuously cycled through not less than 90% of effective-electrical rotational angle (number of turns), at the rate of 1 cycle for 5 seconds minimum to 2.5 a minutes maximum for total of 200 cycles.</p>  <p style="text-align: center;">Figure-4</p> <p>2) PVG3, PVG5series The adjustment rotor (screw) shall be continuously cycled though not less than 90% of effective- electrical rotational angle (number of turns), at the rate of 1 cycle for 5 seconds minimum to 2.5 minutes maximum for a total of 50 (100 for PVG5) cycles, without loading.</p> <p>3) PVF2, PVM4A□□□B01series The wiper shall be rotated over 90% of the effective rotational angle without loading at a speed of 10 cycles per minute, for 100 cycles continuously.</p>

Looking for pricing, stock, or lifecycle information?

Click below to explore more details on WIN SOURCE:

[View PVG5A103A01R00 on WIN SOURCE](#)

[Bourns Inc. Information](#)

Optimize Your Supply Chain with WIN SOURCE Solutions

- ✓ Global Sourcing Solution
- ✓ Obsolete Management
- ✓ Cost Control Management
- ✓ Shortage Management
- ✓ Alternative Solution
- ✓ Excess Inventory Management